



Department of Management Services
Purchasing Division
241 West South Street
Kalamazoo, MI 49007-4796
Phone: 269.337.8020
Fax: 269.337.8500
www.kalamazoo-city.org
purchasing@kalamazoo-city.org

NON-MANDATORY PRE-BID MEETING

Tuesday, July 18, 2023 at 10:00 a.m.

**Kalamazoo Water Reclamation Plant -1415 Harrison Street, Kalamazoo, MI 49007
Conference Room A**

INVITATION FOR BIDS (IFB)

The City of Kalamazoo, Michigan is soliciting sealed bids for:

Project Name: 2023 Water Main Break Road Patch Replacement Bid Reference #: 91395-007.0

IFB ISSUE DATE: July 11, 2023

BID DUE/OPENING DATE: August 8, 2023 at 3:00 p.m. Local Time (ET)

Electronic Bids Will Not Be Accepted.

MAILING ADDRESS & INSTRUCTIONS

Mail to:

Purchasing Division
241 W. South Street
Kalamazoo, MI 49007

Questions about this IFB should be directed to:

Department Contact: **Adam Barnier**,
Senior Civil Engineer, Water Resources at
barniera@kalamazoo-city.org

Include on the Envelope the Project Name and Bid Reference Number. All Envelopes Must Be Sealed.

You are invited to submit a bid for this project. Specifications, terms, conditions and instructions for submitting bids are contained herein. This Invitation for Bids with all pages, documents and attachments contained herein, or subsequently added to and made a part hereof, submitted as a fully and properly executed bid shall constitute the contract between the City and the successful bidder when approved and accepted on behalf of the City by an authorized official or agent of the City. Please review the bid document as soon as possible and note the **DEADLINE FOR QUESTIONS** in the Instructions to Bidders.

All bidders shall complete and return the Bid and Award page(s) and submit all information requested herein in order for a bid to be responsive. The bid document shall be returned in its entirety, in a properly identified and sealed envelope to the Purchasing Division at the above address. **BIDS MUST BE RECEIVED BEFORE THE DUE DATE - LATE BIDS WILL NOT BE CONSIDERED.** The City reserves the right to postpone the bid opening for its own convenience.

TABLE OF CONTENTS

<u>SECTION</u>	<u>PAGE #</u>	<u>APPENDICES</u>
	Statement of No Bid	A – Non-Discrimination
I	Instructions to Bidders	B – Prevailing Wages
II	Bid & Award Pages	Prevailing Wage Rates
III	Indemnity & Insurance	C – Specifications
IV	Special Requirements	
V	General Provisions	
VI	Terms & Conditions	

STATEMENT OF NO BID

NOTE: If you DO NOT intend to bid on this commodity or service, please complete and return this form immediately. Your response will assist us in evaluating all responses for this important project and to improve our bid solicitation process.

The Purchasing Division of the City of Kalamazoo wishes to keep its bidders list file up-to-date. If, for any reason you cannot supply the commodity/service noted in this bid solicitation, this form must be completed and returned to remain on the particular bid list for future projects of this type.

If you do not respond to this inquiry within the time set for the bid opening date and time noted, we will assume that you can no longer supply this commodity/service, and your name will be removed from this bid list.

- _____ Specifications too "tight", i.e. geared toward one brand or manufacturer only (explain below).
- _____ Specifications are unclear (explain below).
- _____ We are unable to meet specifications.
- _____ Insufficient time to respond to the Invitation for Bid.
- _____ Our schedule would not permit us to perform.
- _____ We are unable to meet bond requirements.
- _____ We are unable to meet insurance requirements.
- _____ We do not offer this product or service.
- _____ Remove us from your bidders list for this commodity or service.
- _____ Other (specify below).

REMARKS: _____

SIGNED: _____ NAME: _____
(Type or Print)

TITLE: _____ DATE: _____

FIRM NAME: _____
(if any)

ADDRESS: _____
(Street address) (City) (State) (Zip)

PHONE: _____ FAX: _____

EMAIL: _____

**SECTION I
INSTRUCTIONS TO BIDDERS**

1. **EXAMINATION OF BID DOCUMENT**-Before submitting a bid, bidders shall carefully examine the specifications and shall fully inform themselves as to all existing conditions and limitations. The bidder shall indicate in the bid the sum to cover the cost of all items included on the bid form.
2. **PREPARATION OF BID**-The bid shall be legibly prepared in ink or typed. If a unit price or extension already entered by the bidder on the Bid and Award form is to be altered, it shall be crossed out and the new unit price or extension entered above or below and initialed by the bidder with ink. The bid shall be legally signed and the complete address of the bidder given thereon.

All bids shall be tightly sealed in an envelope plainly marked SEALED BID and identified by project name, bid opening date and time. Bids opened by mistake, due to improper identification, will be so documented and resealed. The Purchasing Division will maintain and guarantee confidentiality of the contents until the specified opening date and time. Bids submitted electronically will not be accepted.

3. **EXPLANATION TO BIDDERS**-Any binding explanation desired by a bidder regarding the meaning or interpretation of the Invitation for Bids (IFB) and attachments must be requested in writing, at least 5 business days before the bid opening (July 31, 2023 by 3:00 p.m.) so a reply may reach all prospective bidders prior to the submission of bids. Any information given to a prospective bidder concerning the IFB will be furnished to all prospective bidders as an amendment or addendum to the IFB if such information would be prejudicial to uninformed bidders. Receipt of amendments or addenda by a bidder must be acknowledged in the bid by attachment, or by letter or fax received before the time set for opening of bids. Oral explanation or instructions given prior to the opening will not be binding.
4. **CASH DISCOUNTS**-Discount offered for payment of less than thirty (30) days will not be considered in evaluating bids for award. Offered discounts of less than thirty (30) days will be taken if payment is made within the discount period, even though not considered in evaluation of the bid.
5. **WITHDRAWAL OF BIDS**-Bids may be withdrawn in person by a bidder or authorized representative, provided their identity is made known and a receipt is signed for the bid, but only if the withdrawal is made prior to the exact time set for receipt of bid. No bid may be withdrawn for at least ninety (90) days after bid opening.
6. **ALTERNATE BIDS**-bidders are cautioned that any alternate bid, unless specifically requested or any changes, insertions or omissions to the terms and conditions, specifications or any other requirement of this IFB may be considered non-responsive, and at the option of the City, result in rejection of the alternate bid.
7. **LATE BIDS**-Any bid received at the office designated herein after the exact time specified for receipt will not be considered. (Note: The City reserves the right to consider bids that have been determined by the City to be received late due to mishandling by the City after receipt of the bid and no award has been made.)
8. **UNIT PRICES**-If there is a discrepancy between unit prices and their extension, unit prices shall prevail.
9. **BID SUBMITTAL**- Bidders can submit sealed bids in one of the following ways:
 - 9.1. **Mail your bid**, to be received before the bid due date and time indicated in the bid document, to the City of Kalamazoo at the following address:

City of Kalamazoo
Purchasing Division
241 West South Street
Kalamazoo, MI 49007

- 9.2. **Deliver your bid to City Hall In-Person** before the bid due date and time indicated in the bid document.
- 9.3. **Deliver your bid to the Treasurer’s Office Payment Drop Box** located in the northwest corner of City Hall (see photos below) before the bid due date and time indicated in the bid document.

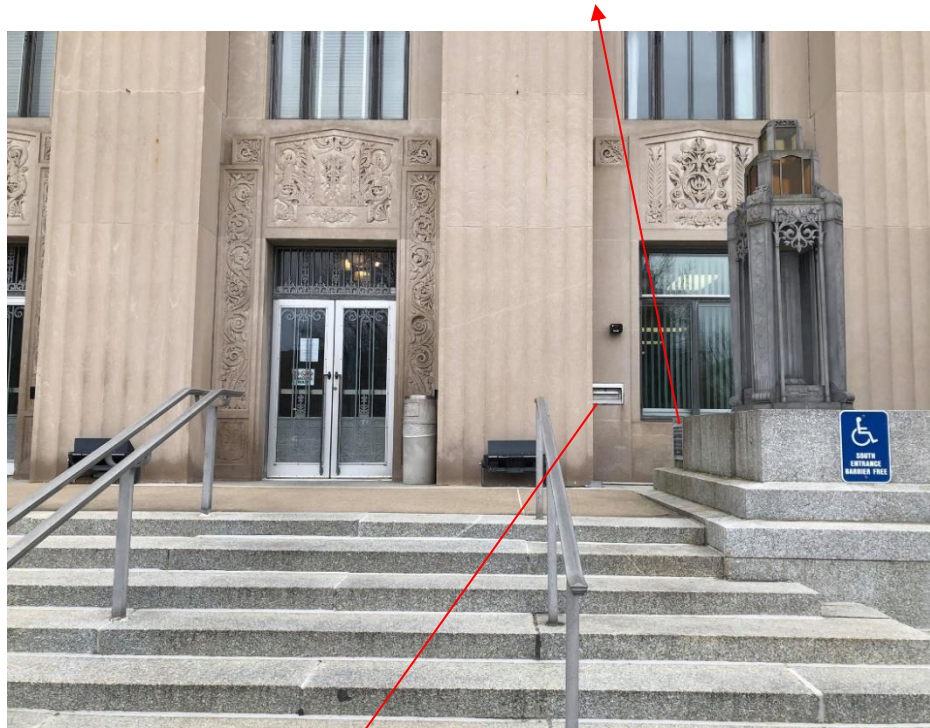

1. Open drop box located at City Hall.



2. Insert SEALED BID here.



- 10. **BID TABULATIONS-** The Purchasing Division makes an effort to post bid tabulations to the City of Kalamazoo website within 24 hours after the bid opening date and time at: <https://www.kalamazoocity.org/bidopportunities>. However, in certain cases the posting of the bid tabulation may extend beyond the 24-hour window.

**SECTION II
BID AND AWARD**

The undersigned having become thoroughly familiar with all of the bid/contract documents incorporated herein, the project site and the location conditions affecting the work, hereby proposes to perform everything required to be performed in strict conformity with the requirements of these documents, and to provide and furnish all the equipment, labor and materials necessary to complete in a professional manner the furnishing and installing of all of the following, meeting or exceeding the specifications as set forth herein for the prices as stated below.

2023 Water Main Break Road Patch Replacement

Item	Description	Qty	Unit	Unit Price	Extended Price
1	Mobilization	1	LS		
2	Traffic Control	47	EA		
3	Removal of Existing Patch	900	SY		
4	24" CIP MDOT Class III Subbase	700	CY		
5	8" CIP MDOT 22A Aggregate Base	250	CY		
6	HMA 13A Base Course	120	Ton		
7	HMA 13A Leveling Course	120	Ton		
8	HMA 13A or 36A Wearing Course	360	Ton		
9	Cold Milling, 2"	2000	SY		
PROJECT TOTAL					

PRODUCT SUBSTITUTION

(must conform with procedure outlined in SECTION V, GENERAL PROVISIONS, 26. PRODUCT/SYSTEM SUBSTITUTIONS):

(Substitute Submitted)

(Substitute Submitted)

(Substitute Submitted)

Bidder shall provide all of the information as requested herein with their bid. **Failure to do so and/or failure to provide post-bid requested information may be cause for rejecting the bid as non-responsive.**

Work shall start within **10** working days after receipt of notification by Contractor of Notice to Proceed and shall be completed by **October 30, 2023**.

Bidder/Contractor has examined and carefully studied the bidding documents and attachments, and acknowledges receipt of the following addenda:

Addendum No: _____

Dated: _____

The City encourages the use of local labor in fulfilling the requirements of this contract.

This contract shall be governed by the laws of the State of Michigan.

By my signature below, I certify that the firm bidding on this contract, when making hiring decisions, does not use a past criminal conviction as a bar to or preclude a person with a criminal conviction from being considered for employment with the bidding firm unless otherwise precluded by federal or state law. I further certify that I have read and agree to be bound by the provisions of the City’s Non-Discrimination Clause found in Appendix A as updated by City Ordinance 1856.

Signed: _____ Name: _____

Title: _____

CITY OF KALAMAZOO EX-OFFENDER POLICY CHECKLIST

As part of the City’s commitment to reducing unacceptable poverty, encouraging rehabilitation, reducing recidivism and strengthening families in Kalamazoo, the City has updated its Purchasing Policy to ensure that firms with whom the City does business share in this commitment by utilizing hiring practices that do not unfairly deny people with arrest and conviction records gainful employment. *(Important: This requirement also extends to any subcontractors the bidder intends to use to fulfill the contract for goods or services being sought from the City.)*

Part I: Proof that the bidder does not inquire about an individual’s past arrest or criminal history on the bidders employment application form

- Attach a copy of the current application for employment being used by the bidder

Part II: Certification that the bidder does not use an individual’s past arrest or criminal history to unlawfully discriminate against them by checking *one or more* of the following:

- That pursuant to federal or state law bidder is precluded from hiring persons with certain criminal records from holding particular positions or engaging in certain occupations by providing a cite to the applicable statute or regulation; if checking this box, provide a citation to the applicable statute or rule upon which the bidder is relying:_____
- That bidder conducts criminal history background checks only as necessary, and only after making a conditional offer of employment; that any withdrawal of an offer of employment to an individual because of a past criminal history is job-related and consistent with business necessity after the individual has been provided an individualized assessment opportunity to review and challenge or supplement the history of past criminal conduct being relied upon by the bidder;
- That the use by bidder of criminal history background checks complies with the U.S. Equal Employment Opportunity Commission’s Enforcement Guidance on the Consideration of Arrest and Conviction Records in Employment Decisions and that the bidder has not had a determination rendered against it in past 7 years that it discriminated against a person through the use of an individual’s arrest or criminal history

I CERTIFY THAT THE ABOVE STATEMENTS ARE TRUE.

Date

Signature

Printed Name

Position

**CITY OF KALAMAZOO
LOCAL PREFERENCE POLICY AND CERTIFICATION**

The lowest responsive Kalamazoo County bidder whose bid is not low but falls within 2% of the lowest responsive bid is afforded the opportunity to become the successful bidder if it agrees to reduce its bid to match the lowest responsive bid. The City of Kalamazoo is the sole determiner whether a bidder is responsible, qualifies as a Kalamazoo County bidder, and if its bid is responsive to the City’s specifications, terms and conditions.

If the lowest Kalamazoo County bidder chooses not to match the lowest bid, the next lowest responsive Kalamazoo County bidder whose bid falls within 2% of the lowest bid, is given the opportunity to match the lowest responsive bid.

To qualify as a Kalamazoo County bidder, the bidder must meet both the following criteria:

1. Have a physical presence in Kalamazoo County by maintaining a permanent office, factory or other facility in Kalamazoo County with employees working in Kalamazoo County.
2. Have paid real or personal property taxes related to said business to the City of Kalamazoo, County of Kalamazoo or other municipal corporation within Kalamazoo County in the previous tax year, except that a non-profit entity need not meet this requirement.

This local preference policy applies only to purchases for materials, supplies, capital outlay, and services for maintenance, repair or operation of City facilities that are over \$25,000. If more than 50% of the contract is sub-contracted to firms located outside of Kalamazoo County that bid does not qualify for the local preference policy outlined above. The local preference policy will not apply if prohibited by law. The Purchasing Agent has the authority to finally determine if the bidder qualifies as a Kalamazoo County bidder as set forth herein. The Purchasing Agent may take into account the permanency of the business in Kalamazoo, and whether the business appears to be claiming to be a Kalamazoo County business solely or primarily to qualify as a Kalamazoo County business under this Resolution, and any other material factors.

CERTIFICATION

If you qualify as a Kalamazoo County bidder and wish to be considered for the local preference provisions as provided above please certify that fact by providing the information requested below and attesting to its accuracy.

Firm Name: _____

Street Address of Business: _____

City, State, and Zip Code: _____

Number of employees working in Kalamazoo County: _____

Name the city or township to which business real and/or personal property taxes are paid or provide non-profit status: _____

The above information is accurate:

Signature: _____ Date: _____

Title: _____

SUB-CONTRACTING INFORMATION

Using the table below provide information regarding the sub-contractors that will be working to fulfill the requirements of this contract. Submit as complete a list as possible at the time of your bid. You will have two business days after the bid opening to update the list as needed. The information provided will be used for evaluating your bid and to assist in determining if you qualify as a Kalamazoo County Bidder.

INSTRUCTIONS:

Nature of Contract - State a brief description of the work or product that will be provided.

BIDDER – Provide the percentage of services or construction activity that will be provided by your firm.

Subcontractors:

- Provide the Name and Address for each subcontractor providing services or construction activities for this contract.
- Indicate with **YES** or **NO** under the “Local?” box if they qualify as a “Kalamazoo County bidder” (see local preference certification page)
- Provide the percentage for the dollar amount of the contract work they will be performing.

If there are not enough lines in the table below make additional copies as needed.

Nature of Contract:		
Subcontractor Name/Address	Local?	% Of Total Contract
<i>BIDDER</i>		

Does this List of Subcontractors need to be updated after the bid opening? **Yes** ___ **No** ___

REFERENCE QUESTIONNAIRE

Please answer the following questions completely.

1. Firm name: _____
2. Established: Year _____ Number of Employees: _____
3. Type of organization:
 - a. Individual: _____
 - b. Partnership: _____
 - c. Corporation: _____
 - d. Other: _____
4. Former firm name(s) if any, and year(s) in business:

5. Include at least 3 references of contracts for similar work performed over the last five (5) years. Include: owner, contact person and phone number and description of work performed.
 - 5.1 Company Name: _____
Address: _____
Phone: _____
Contact: _____
Type of work or contract: _____
 - 5.2 Company Name: _____
Address: _____
Phone: _____
Contact: _____
Type of work or contract: _____
 - 5.3 Company Name: _____
Address: _____
Phone: _____
Contact: _____
Type of work or contract: _____

I hereby certify that all of the information provided is true and answered to the best of my ability.

Signed: _____ Name: _____
(type or print)

Title: _____ Date: _____

I hereby state that all of the information I have provided is true, accurate and complete. I hereby state that I have the authority to submit this bid which will become a binding contract if accepted by the City of Kalamazoo. I hereby state that I have not communicated with nor otherwise colluded with any other bidder, nor have I made any agreement with nor offered/accepted anything of value to/from an official or employee of the City of Kalamazoo that would tend to destroy or hinder free competition.

The firm's identification information provided will be used by the City for purchase orders, payment and other contractual purposes. If the contractual relationship is with, or the payment made to, another firm please provide a complete explanation on your letterhead and attach to your bid. Please provide for accounts payable purposes:

Tax Identification Number (Federal ID): _____

Remittance Address: _____

Financial Contact Name: _____ Financial Contact Phone Number: _____

Financial Contact Email Address: _____

I hereby state that I have read, understand and agree to be bound by all terms and conditions of this bid document.

SIGNED: _____ NAME: _____
(Type or Print)

TITLE: _____ DATE: _____

FIRM NAME: _____
(if any)

ADDRESS: _____
(Street address) (City) (State) (Zip)

PHONE: _____ FAX: _____

EMAIL ADDRESS: _____

FOR CITY USE ONLY - DO NOT WRITE BELOW

**SECTION III
CITY OF KALAMAZOO
INDEMNITY AND INSURANCE**

Contractor, or any of their subcontractors, shall not commence work under this contract until they have obtained the insurance required under this paragraph, and shall keep such insurance in force during the entire life of this contract. All coverage shall be with insurance companies licensed and admitted to do business in the State of Michigan and acceptable to the City of Kalamazoo within ten (10) days of the Notice of Award. The requirements below should not be interpreted to limit the liability of the Contractor. All deductibles and SIR's are the responsibility of the Contractor.

The Contractor shall procure and maintain the following insurance coverage:

Workers' Compensation Insurance including Employers' Liability Coverage, in accordance with all applicable statutes of the State of Michigan.

Commercial General Liability Insurance on an "Occurrence Basis" with limits of liability not less than \$1,000,000 per occurrence and aggregate. Coverage shall include the following extensions: (A) Contractual Liability; (B) Products and Completed Operations; (C) Independent Contractors Coverage; (D) Broad Form General Liability Extensions or equivalent, if not already included and (E) XCU coverage if the nature of the contract requires XC or U work.

Automobile Liability in accordance with all applicable statutes of the State of Michigan, with limits of liability not less than \$1,000,000 per occurrence, combined single limit for Bodily Injury, and Property Damage. Coverage shall include all owned vehicles, all non-owned vehicles, and all hired vehicles.

Additional Insured: Commercial General Liability and Automobile Liability, as described above, shall include an endorsement stating that the following shall be *Additional Insureds*: The City of Kalamazoo, all elected and appointed officials, all employees and volunteers, all boards, commissions, and/or authorities and board members, including employees and volunteers thereof. It is understood and agreed that by naming the City of Kalamazoo as additional insured, coverage afforded is considered to be primary and any other insurance the City of Kalamazoo may have in effect shall be considered secondary and/or excess.

To the fullest extent permitted by law the Contractor agrees to pay on behalf of, indemnify, and hold harmless the City of Kalamazoo, its elected and appointed officials, and employees against any claims, demands, suits, or loss, including all costs connected therewith, and for any damages which may be asserted, claimed, or recovered against or from the City of Kalamazoo, by reason of personal injury, including bodily injury or death and/or property damage, including loss of use thereof, caused in whole or part by any negligent act or omission by the Contractor, its employees, agents, or officers which arises out of, or is in any way connected or associated with, this contract.

Cancellation Notice: All policies, as described above, shall include an endorsement stating that it is understood and agreed that thirty (30) days, or ten (10) days for non-payment of premium, Advance Written Notice of Cancellation, Non-Renewal, Reduction, and/or Material Change shall be sent to: City of Kalamazoo, Purchasing Division, 241 W. South Street, Kalamazoo, MI 49007.

Proof of Insurance Coverage: The Contractor shall provide the City of Kalamazoo at the time that the contracts are returned by him/her for execution, or within 10 days of Notice of Award, whichever is earlier, a Certificate of Insurance as well as the required endorsements. In lieu of required endorsements, if applicable, a copy of the policy sections where coverage is provided for additional insured and cancellation notice would be acceptable. Copies or certified copies of all policies mentioned above shall be furnished, if so requested.

INDEMNITY AND INSURANCE
Continued

If any of the above coverages expire during the term of this contract, the Contractor shall deliver renewal certificates and/or policies to City of Kalamazoo at least ten (10) days prior to the expiration date.

Scope of Coverage: The above requirements and conditions shall not be interpreted to limit the liability of the Contractor under this Contract, but shall be interpreted to provide the greatest benefit to the City and its officers and employees. The above listed coverages shall protect the Contractor, its employees, agents, representatives and subcontractors against claims arising out of the work performed. It shall be the Contractor's responsibility to provide similar insurance for each subcontractor or to provide evidence that each subcontractor carries such insurance in like amount prior to the time such subcontractor proceeds to perform under the contract.

**SECTION IV
SPECIAL REQUIREMENTS**

1. BID BOND/GUARANTEE

The bid must be accompanied by a bid bond which shall not be less than five (5%) percent of the total amount of the bid. No bid will be considered unless it is accompanied by the required guarantee. The bid guarantee shall ensure the execution of the bid and award, and the furnishing of a performance bond and a labor and material bond (A and B below) by the successful bidder. (Contractors Note: A cashier's or certified check in lieu of a bid bond is **NOT** acceptable.)

A. PERFORMANCE BOND

A performance bond shall be furnished in the full amount of the contract ensuring the City of faithful performance of all the provisions of the contract, and the satisfactory performance of any equipment required hereunder. The bond shall also ensure the City against defective workmanship and/or materials.

B. LABOR AND MATERIAL (PAYMENT) BOND

A labor and material (payment) bond shall be furnished for the period covered by the contract, in the full amount of the contract for the protection of labor and material suppliers and sub-contractors.

Bonds shall be secured by a guaranty or a surety company listed in the latest issue of the U.S. Treasury, circular 570, and licensed to do business in the State of Michigan, and written in favor of the City of Kalamazoo. The amount of such bonds shall be within the maximum amount specified for such company in said circular 570. The bonds shall be accompanied by a power of attorney showing authority of the bonding agent to sign such bonds on behalf of the guaranty or surety company. The cost of the bonds shall be borne by the Contractor.

Failure of the Contractor to supply the required bonds within ten (10) days after Notice of Award, or within such extended period as the Purchasing Agent may agree to, shall constitute a default and the City of Kalamazoo may either award this contract to the next lowest bidder or re-advertise for bids and may charge against the Contractor for the difference between the amount of the bid and the amount for which a contract for the work is subsequently executed, irrespective of whether the amount thus due exceeds the amount of the bid bond. If a more favorable bid is received by re-advertising, the defaulting bidder shall have no claim against the City of Kalamazoo for a refund.

2. WAIVERS OF LIEN

Upon completion of all work and request for final payment, the Contractor shall furnish a 100% waiver of lien from each supplier and sub-contractor covering all items of the work. Failure to supply waivers of lien for the entire job upon completion and final payment request will be considered grounds for withholding final payment.

3. SUBCONTRACTORS

- A. Contractors shall state on the Bid and Award page any and all subcontractors to be associated with their bid, including the type work to be performed. Any and all subcontractors shall be bound by all of the terms, conditions and requirements of the contract; however, the prime contractor shall be responsible for the performance of the total work requirements.
- B. The Contractor shall cooperate with the City of Kalamazoo in meeting its commitments and goals with regard to maximum utilization of minority and women business enterprise, and shall use its best efforts to ensure that minority and women business enterprises have maximum practicable opportunity to compete for subcontract work under this agreement.

4. PREVAILING WAGES

The successful bidder will be required to comply with Section 2-125 of the Code of Ordinances of the City of Kalamazoo regarding prevailing wages and Appendix B attached, incorporated herein by reference. Special note: This provision applies only to projects in excess of \$100,000 for City (\$2,000 federal) funded projects.

The City's requirements as it relates to prevailing wages includes a meeting with the City's Purchasing Division **prior** to work and payroll and work monitoring during the duration of the contract. Please contact Purchasing at (269) 337-8020 if you have any questions regarding Davis-Bacon provisions.

SECTION V
GENERAL PROVISIONS

1. INTENT

It is the intent of these plans and specifications to provide for a contractor who shall provide all labor, materials, tools and equipment necessary to remove existing concrete patches over city utilities and replace with HMA.

2. SCOPE OF WORK

This contract includes but is not limited to: All work as described in the specifications for the removal of approximately 47 concrete patches and replacement with HMA as outlined in this document and its appendices.

The bidder shall furnish all labor, supervision, supplies, tools, equipment and other means necessary or proper for performing and completing the work. The bidder shall be responsible for the cleaning up of the job site and shall repair or restore all structures and property that may be damaged or disturbed during performance of the work to the satisfaction of the Public Services Department for the City of Kalamazoo. Where needed, all traffic control used for such operations as defined by the MMUTCD will be the responsibility of the bidder.

The bidder shall have all work completed by October 30, 2023.

3. QUANTITIES

Payment will be made based upon unit pricing of quantities installed.

4. UNIT PRICING

The unit price, including its pro-rata share of overhead, multiplied by the quantity shown shall represent the total bid and shall be held firm for the life of this contract. Any bid not conforming to this requirement may be rejected as non-responsive.

5. INSPECTION OF WORK

The City may maintain inspectors on the job who shall at all times have access to work. There will not be fees associated with this inspection.

6. INSPECTION OF SITE

Each bidder shall visit the site of the proposed work and fully acquaint himself/herself with the existing conditions relating to construction and labor and shall fully inform himself/herself as to the facilities involved and the difficulties and restrictions attending the performance of this contract. The bidder shall thoroughly examine and become familiar with the drawings, specifications and all other bid/contract documents. The Contractor, by the execution of this contract, shall in no way be relieved of any obligation under it due to his/her failure to receive or examine any form or legal instrument, or to visit the site and acquaint himself/herself with the conditions there existing. No allowance shall be made subsequently in this connection in behalf of the Contractor for any negligence of his/her part. For inspection call the Public Services Department, Water Resources Division.

7. INSPECTION AND TESTING

The Contractor shall give the Project Manager timely notice of readiness of the work for all required inspections, tests or approvals, and shall cooperate with inspections and testing personnel to facilitate required inspections or tests. The City will provide for materials and construction testing including but not limited to compaction of subbase and backfill material, concrete testing and asphalt testing. The cost of said testing shall be borne by the City. Verification that testing required by the contract has been completed on one phase of the project prior to proceeding to the next phase is the responsibility of the Contractor. In the event that the project has proceeded without required testing, the Contractor shall insure that the required testing is obtained retroactively and shall provide access for testing as necessary at his/her sole expense.

8. MATERIALS INSPECTION AND RESPONSIBILITY

8.1 The Project Manager shall have the right to inspect any materials to be used in carrying out the terms of the contract.

8.2 The City does not assume any responsibility for the contracted quality and standard of all materials, equipment, components or completed work furnished under this contract.

8.3 Any materials, equipment, components or completed work which does not comply with contract specifications, MDOT, or State codes may be rejected by the City, and shall be replaced by the Contractor at no cost to the City.

8.4 Any materials, equipment or components rejected shall be removed within a reasonable period of time from the premises of the City at the entire expense of the Contractor after notice has been given by the City to the Contractor that such materials, equipment or components have been rejected.

9. LAYING OUT WORK

Before submitting a bid the Contractor shall verify all measurements and shall be responsible for the correctness of same. No extra charge or compensation will be allowed on account of differences between actual dimensions and the measurements indicated on the drawings. Any difference that may be found shall be submitted to the City Engineer for consideration before proceeding. The Contractor shall provide staking for the project.

10. SUPERVISION

The Contractor shall employ an experienced superintendent or foreperson on the job at all times.

11. TEMPORARY UTILITIES

11.1 Temporary or construction water will NOT be available on the sites. The Contractor must provide for drinking water.

11.2 Temporary toilets: To be supplied by the Contractor as may be necessary.

12. SITE SECURITY

The Contractor shall be responsible for job site security of all materials and tools provided by him/her and no claim for loss or damage will be considered by the City.

13. TARDINESS

Construction delays resulting from tardiness on the part of the Contractor will be reviewed by the City in the event of any request for contract extension by the Contractor.

14. PROGRESS SCHEDULE

- 14.1 After receipt of Notice to Proceed, work shall start within 10 days unless otherwise agreed to by the Project Manager.
- 14.2 **Project shall have a final completion date of October 30, 2023.**
- 14.3 Work of a similar nature may be added to this contract if agreed to by the City and the Contractor. In the event that work is added, the progress schedule for the work will remain unchanged. Any contract time added for additional work will be applied to that additional work only, and cannot be added to items in the original contract. Any work done on the items in the original contract past the number of working days stated herein will be subject to liquidated damages regardless of any work that may be added at a later date.
- 14.4 The Contractor will be required to meet with the Public Services representatives to work out detailed progress schedule. The schedule for this meeting will be within two weeks after contract award has been made.
- 14.5 The named sub-contractor(s) for all items shall also be present at the scheduled meeting and they will be required to sign the Progress Schedule to indicate their approval of the scheduled dates of work set forth in the Progress Schedule.
- 14.6 The Progress Schedule shall include, as a minimum, the starting and completion dates for major items, and where specified in the bid document the date the project is to be opened to traffic as well as the final project completion date specified in the bid documents. The Progress Schedule shall be coordinated with all aspects of the work occurring at the site.
- 14.7 Failure on the part of the Contractor to carry out the provisions of the Progress Schedule as established may be considered sufficient cause to prevent bidding future projects until a satisfactory rate of progress is again established.
- 14.8 The starting date and the contract time to the completion date for this project may be adjusted by Public Services without imposing liquidated damages upon the receipt of satisfactory documented evidence that unforeseen delayed delivery of critical materials will prevent the orderly prosecution the work.
- 14.9 Section 501.03.I.2, Seasonal Limitations, is amended as follows: Seasonal limits for placing HMA mixtures in the City of Kalamazoo will be May 5 thru Oct. 15. No HMA paving will be allowed outside of these dates unless approved by the Engineer.

15. CONSTRUCTION SCHEDULE AND COORDINATION

- 15.1 The Contractor shall supply the City with an agreeable construction schedule before commencing work on this contract. This schedule shall detail beginning and completion dates for each major component of the project.
- 15.2 The Contractor shall coordinate and cooperate with all other contractors who may be working on the site in order to allow for the orderly progress of work being done.
- 15.3 The Contractor is required to keep the Project Manager fully informed of any proposed work which will tend to interfere with the existing operations at the site.
- 15.4 The Contractor shall schedule all work to accommodate the City's schedule. In the event Contractor's schedule falls on weekends, nights or overtime work is required, no additional compensation will be allowed. All work shall be part of this contract without regard to when it is done.

16. CONTRACTOR COORDINATION

- 16.1 The Contractor shall make every effort to coordinate every aspect of his work with that of other contractors on the site to assure an efficiently managed and proper installation. Special attention shall be given by the site contractor to the coordination with the playground equipment installation contractor and vice versa.
- 16.2 Consideration shall be given to timing of construction, maintaining adequate construction access, and construction staging. Any costs associated with this coordination shall be included in the contract.

17. COORDINATING CLAUSE

The Contractor's attention is called to Article 104.08 of the MDOT 2020 Standard Specifications for Construction entitled "Cooperation by the Contractor."

18. ADDITIONS

- 18.1 Any modification to the contract shall be subject to prior approval by the Purchasing Agent. City Commission approval may also be required.
- 18.2 Prices for additional work required are not requested in the itemized listing contained herein for the base project. Should additional work be authorized, compensation shall be made on the basis of price or prices to be mutually agreed upon. Such additional work shall not begin until a Change Order has been approved.

19. MAINTAINING TRAFFIC

- 19.1 This work shall be in accordance with the requirements of Section 812 of the MDOT Standard Specifications for Construction and as specified herein. The Contractor is advised that the current Michigan Manual of Uniform Traffic Control Devices is hereby established as governing all work in connection with traffic control devices, barricade lighting, etc. required on this project.
- 19.2 The Contractor shall furnish, erect, maintain and, upon completion of the work, remove all traffic control devices and barricade lights within the project and around the perimeter of the project for the safety and protection of through and local traffic. This includes, but is not limited to: Advance, regulatory and warning signs; barricades and channeling devices at intersecting streets on which traffic is to be maintained; barricades at the ends of the project and at right-of-way lines for intersecting streets which are to be closed with the first usable street on each side of the project. Traffic regulators, where required by the Engineer, are included.
- 19.3 Where the existing pavement or partial widths of new pavement are to be utilized for the maintenance of through and local traffic, drum type barricades will be required at 50' intervals or as directed by the Engineer for channeling and directing traffic through the construction area.
- 19.4 Through traffic shall be maintained utilizing sidewalk closures with detours and traffic shifts per MDOT traffic and safety details.
- 19.5 Protection of all pedestrian traffic shall be maintained at all times.
- 19.6 Payment for the traffic control devices shall be based on the quantity used and the contract unit prices.

19.7 Under Article 812.04.D "Operated Pay Items" the term 'Relocating' shall include the relocating of the item from any street covered by the contract to any other street covered by the contract.

Special Restrictions: Access to frontage properties shall be maintained as much as practical. Emergency access shall be maintained at all times. The Contractor shall maintain two-way traffic with flag control as needed when the road is restricted to only one traffic lane.

20. LIQUIDATED DAMAGES

Liquidated damages, if applicable, shall be \$500.00 a day regardless of contract size.

21. REMOVAL OF RUBBISH

The Contractor shall daily remove all rubbish and accumulated materials due to his/her construction.

22. SITE ACCESS

The City will provide fair and reasonable access to the job site within the working schedules of both parties.

23. GUARANTEE

The Contractor shall guarantee all of his/her work for a period of two (2) years following the date of final acceptance of the completed work and shall repair, replace or make good any materials or work which fail to function or perform or be found defective, without cost to the City.

24. SAFETY

The Contractor shall comply with all applicable OSHA and MIOSHA regulations.

25. PAY ESTIMATES

The Contractor shall be responsible for the generation of invoices for payment. Payment will be generated by the City based upon an approved invoice. Recommended frequency of payment is monthly, however, frequency of payment will not exceed bi-weekly.

26. PRODUCT/SYSTEM SUBSTITUTIONS

The inclusion of a manufacturer's name, trademark, or other proprietary identification of a product shall not limit competition but shall establish a standard of quality. However, the substitution of a product in place of that specified shall be permitted only upon the Owner's issuance of written approval in the form of an Addendum, following the procedure as outlined below.

Submit a written request, to be received not later than 14 days prior to scheduled bid opening, for Substitution of any Product not named. If no substitutions are submitted, it will be reasonably concluded by the Owner that the specified product will be incorporated into the Work and the Bidder will be committed to supplying the specified product.

26.1 Describe in detail any variance to the Product specified. All proposed substitution for specified items shall be substantially the same size (height, length, width, diameter, etc.), type, color, construction quality and shall meet the design intent to be considered for substitution for the Product specified.

26.2 Document each request with complete data substantiating compliance of proposed Substitution with Product specified including written certification that Product conforms to or exceeds all requirements of the Product specified.

- 26.3 Document all coordination information, including a list of changes or modifications needed to the Contract Documents or other parts of the Work and to construction performed by the Owner and Separate Contractors that will become necessary to accommodate the proposed substitution.
- 26.4 Provide name, address and telephone number of manufacturer's authorized representative.
- 26.5 Submit three copies of all documents for each request for Substitution for consideration.
- 26.6 Approval of the Substitution request, if given, will be in the form of an addendum issued prior to scheduled opening date and hour at local time.

27. SAMPLES AND DEMONSTRATIONS

Evidence in the form of samples may be requested. Such samples are to be furnished after the date of bid opening only upon request of the City unless otherwise stated in the bid proposal. If samples should be requested, such samples must be received by the City no later than seven (7) days after formal request is made. When required, the City may request full demonstrations of any unit(s) bid prior to the award of any contract. Samples, when requested, must be furnished free of expense to the City and if not used in testing or destroyed, will upon request within thirty (30) days of bid award be returned at the bidder's request.

28. ACCEPTANCE OF MATERIAL

The material delivered under this proposal shall remain the property of the seller until a physical inspection and actual usage of the material and/or services is made and thereafter accepted to the satisfaction of the City and must comply with the terms herein, and be full in accord with specifications and of the highest quality. In the event the material and/or service supplied to the City is found to be defective or does not conform to specifications, the City reserves the right to cancel the order upon written notice to the seller and return the product to seller at the seller's expense.

29. VARIATIONS TO SPECIFICATIONS

For purposes of evaluation, the bidder **MUST** indicate any variances from our specifications, terms and/or conditions, no matter how slight. If variations are not stated in the proposal, it will be assumed that the product or service fully complies with our specifications, terms and conditions.

30. SAFETY STANDARDS

The bidder warrants that the products supplied to The City conform in all respects to the standards set forth in the Occupational Safety and Health Act of 1970 and its amendments and the failure to comply with this condition will be considered a breach of contract.

31. MANUFACTURER'S CERTIFICATION

The City reserves the right to request from bidders separate manufacturer certification of all statements made in the bid.

32. PROTECTION OF WORK

The Contractor shall maintain adequate protection of all his/her work from damage and shall protect all public and private abutting property from injury or loss arising in connection with this contract.

33. PROTECTION OF PROPERTY

33.1 The Contractor shall confine his/her equipment and operations to those areas of the work site necessary for the completion of the work, or as authorized by the Project Manager. The Contractor shall protect and preserve from damage any facilities, utilities or features including trees, shrubs and turf which are not required to be disturbed by the requirements of the work.

33.2 The Contractor shall be responsible to determine the location of and to protect from damage any utilities or other improvements.

34. PERMITS

The contractor shall obtain necessary Right-of-Way permits.

35. PROJECT MANAGER’S STATUS

The City Engineer (Engineer) or their duly authorized representative shall be the City’s Project Manager and shall have the duties and responsibilities as provided in the contract.

The Project Manager shall have the authority to reject any work or materials which do not conform to the contract and to decide questions or interpretations which may arise from the contract documents.

The Contractor shall immediately report to the Project Manager any questionable or obvious error or omission which may be apparent in the contract documents and shall not proceed with work until the Project Manager has resolved the error or omission.

36. SPECIFICATIONS FOR CONSTRUCTION

The items of work in this contract shall conform to the Michigan Department of Transportation (MDOT) 2020 Standard Specifications for Construction, MDOT Supplemental Specifications, and/or the City of Kalamazoo Standard Specifications unless superseded by a Special Provision contained in this document.

37. QUANTITIES

The quantities shown on the Bid and Award pages are approximate only and may be subject to increase or decrease. No guarantee of maximum or minimum is given.

38. BASIS FOR PAYMENT

Payment shall be based on the bid unit price for each work item and the approved constructed quantity for that work item. Due to potential differences in conditions between the plans and the field, final as built quantities may be different than contained in the bid document. The City does not guarantee quantities and will pay only for "as built" quantities approved by the Project Manager or his representative. Quantities in excess of those approved shall be at the Contractor's own expense, the City will not be responsible for any excess quantities not approved. Should an item of work have to be redone, such as replacing new walk because the Contractor failed to adequately protect the wet concrete from rain or pedestrian or vehicular damage, such work shall be replaced at the Contractor's expense. Should changes in design result in the Project Manager directing the removal and reinstallation of already completed work prior to final completion and acceptance of the project, such removal and installation shall be paid for based on as-bid unit prices and the quantities removed and installed.

39. PAYMENT TO CONTRACTOR

The Project Manager will be responsible for approving all measured quantities of work. Once measured quantities are approved, the Contractor shall submit a pay invoice to the City of Kalamazoo Attn: Accounts Payable at 241 West South Street, Kalamazoo MI, 49007. The contractor is required to meet with the Project Manager to verify final constructed quantities within 60 days of project completion. In the event of a disagreement the Project Manager's measured quantities shall be considered final.

40. WORK HOURS

All work shall be done between the hours of 7 am to 7 pm (Monday – Saturday). Work done outside of these times will be at the discretion of the Project Manager.

No work shall be done on Sunday, unless otherwise approved by the Project Manager in writing.

The Contractor shall conduct their work in such a manner that no excavations are left open overnight. If this is not possible, the Contractor shall provide and install a temporary fence to protect the excavation, at the Contractor's expense.

41. NON-MANDATORY PRE-BID MEETING

All prospective contractors and subcontractors are invited to attend a non-mandatory **Pre-Bid Meeting** with representatives from the City of Kalamazoo on **Tuesday, July 18, 2023 at 10:00 a.m. local time (ET)** at the Kalamazoo Water Reclamation Plant, 1415 Harrison Street, Kalamazoo, MI 49007. (Conference Room A)

42. QUESTIONS

Bidders shall address questions regarding the specifications to Adam Barnier, Senior Civil Engineer at barniera@kalamazoocity.org. (This does not relieve the requirements of Page 1, Item 3.) Questions regarding terms, conditions and other related bid requirements may be addressed to Craig Hull, Buyer at (269) 337-8444.

**SECTION VI
TERMS AND CONDITIONS**

1. AWARD OF CONTRACT

- A. This contract will be awarded to that responsible bidder whose bid, conforming to this solicitation, will be most advantageous to the City, price and other factors considered. The City reserves the right to accept or reject any or all bids and waive informalities and minor irregularities in bids received. Other factors include, as an example but not limited to, delivery time, conformance to specifications, incidental costs such as demurrage and deposits, etc.

Notification of award will be in writing by the Purchasing Manager. Upon notification, the Contractor shall submit to the Purchasing Division all required insurance certificates (if required) and such other documentation as may be requested or required hereunder. Upon their receipt and subsequent approval by the City, the Purchasing Manager will forward to the Contractor a written **NOTICE TO PROCEED**. Work shall **NOT** be started until such **NOTICE TO PROCEED** is received by the Contractor.

- B. Unilateral changes in bid prices by the bidder shall not be allowed. However, the City, at its sole option, reserves the right to negotiate with bidders in the event of, but not limited to:
- 1) No bids received;
 - 2) A single bid being received; or
 - 3) Prices quoted are over budget and/or unreasonable.

2. COMPLETE CONTRACT

This bid document together with its addenda, amendments, attachments and modifications, when executed, becomes the complete contract between the parties hereto, and no verbal or oral promises or representations made in conjunction with the negotiation of this contract shall be binding on either party.

3. SUBCONTRACTORS – NON-ASSIGNMENT

Bidders shall state in writing any and all sub-contractors to be associated with this bid, including the type of work to be performed. The Contractor shall cooperate with the City of Kalamazoo in meeting its commitments and goals with regard to maximum utilization of minority and women-owned business enterprises.

The Contractor hereby agrees and understands that the contract resulting from this solicitation shall not be transferred, assigned or sublet without prior written consent of the City of Kalamazoo.

4. TAXES

The City of Kalamazoo is exempt from all federal excise tax and state sales and use taxes.

5. INVOICING

All original invoice(s) will be sent to the Financial Services Division, 241 W. South Street, Kalamazoo, MI 49007 or via email at apinvoice@kalamazoo.org. The Finance Division processes payments after receipt of an original invoice from the Contractor and approval by the department. The City of Kalamazoo’s policy is to pay invoice(s) within 30 days from the receipt of the original invoice, if the services or supplies are satisfactory and the proper paperwork and procedures have been followed. **In order to guarantee payment to the vendor on a timely basis, the vendor needs to receive a purchase order number before supplying the City of Kalamazoo with goods or services.** All original, and copies of original invoice(s), will clearly state which purchase order they are being billed against.

The City of Kalamazoo is a government municipality and therefore is tax exempt from all sales tax.

The vendor is responsible for supplying the Finance Division with a copy of their W9 if they are providing a service to the City of Kalamazoo.

6. PAYMENTS

Upon issuance of certificates of Payment by the Architect/Engineer for labor and material incorporated in the work and the materials suitably stored at the site payment shall be made up to ninety (90%) percent of the value thereof.

When the cumulative total of payment is equal to fifty (50%) percent of the contract sum, subsequent payments will be made in the full amount for labor and material certified by the Architect/Engineer.

The amount retained shall be held until final acceptance of the work, receipt of all payrolls, releases, and waiver of liens.

7. CHANGES AND/OR CONTRACT MODIFICATIONS

The City reserves the right to increase or decrease quantities, service or requirements, or make any changes necessary at any time during the term of this contract, or any negotiated extension thereof. Price adjustments due to any of the foregoing changes shall be negotiated and mutually agreed upon by the Contractor and the City.

Changes of any nature after contract award which reflect an increase or decrease in requirements or costs shall not be permitted without prior approval by the Purchasing Agent. City Commission approval may also be required.

ANY CHANGES PERFORMED IN ADVANCE OF PURCHASING AGENT APPROVAL, MAY BE SUBJECT TO DENIAL AND NON-PAYMENT.

8. LAWS, ORDINANCES AND REGULATIONS

The Contractor shall keep himself/herself fully informed of all local, state and federal laws, ordinances and regulations in any manner affecting those engaged or employed in the work and the equipment used. Contractor and/or employees shall, at all times, serve and comply with such laws, ordinances and regulations.

Any permits, licenses, certificates or fees required for the performance of the work shall be obtained and paid for by the Contractor.

This contract shall be governed by the laws of the State of Michigan.

9. RIGHT TO AUDIT

The City or its designee shall be entitled to audit all of the Contractor's records, and shall be allowed to interview any of the Contractor's employees, throughout the term of this contract and for a period of three years after final payment or longer if required by law to the extent necessary to adequately permit evaluation and verification of:

- A. Contractor compliance with contract requirements,
- B. Compliance with provisions for pricing change orders, invoices or claims submitted by the Contractor or any of his payees.

10. HOLD HARMLESS

If the negligent acts or omissions of the Contractor/Vendor or its employees, agents or officers, cause injury to person or property, the Contractor/Vendor shall indemnify and save harmless the City of Kalamazoo, its agents, officials, and employees against all claims, judgments, losses, damages, demands, and payments of any kind to persons or property to the extent occasioned from any claim or demand arising therefrom.

11. DEFAULT

The City may at any time, by written notice to the Contractor, terminate this contract and the Contractor's right to proceed with the work, for just cause, which shall include, but is not limited to the following:

- A. Failure to provide insurance and bonds (when called for), in the exact amounts and within the time specified or any extension thereof.
- B. Failure to make delivery of the supplies, or to perform the services within the time specified herein, or any extension thereof.
- C. The unauthorized substitution of articles for those bid and specified.
- D. Failure to make progress if such failure endangers performance of the contract in accordance with its terms.
- E. Failure to perform in compliance with any provision of the contract.

DEFAULT (cont.)

- F. Standard of Performance - Contractor guarantees the performance of the commodities, goods or services rendered herein in accordance with the accepted standards of the industry or industries concerned herein, except that if this specification calls for higher standards, then such higher standards shall be provided.

Upon notice by the City of Contractor's failure to comply with such standards or to otherwise be in default of this contract in any manner following the Notice to Proceed, Contractor shall immediately remedy said defective performance in a manner acceptable to the City. Should Contractor fail to immediately correct said defective performance, said failure shall be considered a breach of this contract and grounds for termination of the same by the City.

In the event of any breach of this contract by Contractor, Contractor shall pay any cost to the City caused by said breach including but not limited to the replacement cost of such goods or services with another Contractor.

The City reserves the right to withhold any or all payments until any defects in performance have been satisfactorily corrected.

In the event the Contractor is in breach of this contract in any manner, and such breach has not been satisfactorily corrected, the City may bar the Contractor from being awarded any future City contracts.

- G. All remedies available to the City herein are cumulative and the election of one remedy by the City shall not be a waiver of any other remedy available to the City.

12. TERMINATION OF CONTRACT

The City may, at any time and without cause, suspend the work of this contract for a period of not more than ninety days after providing notice in writing to the Contractor. The Contractor shall be allowed an adjustment in the contract price or an extension of the contract times, or both, directly attributable to the suspension if Contractor makes an approved claim.

The City may, without prejudice to any other right or remedy of the City, and with or without cause, terminate the contract by giving seven days written notice to the Contractor. In such case the Contractor shall be paid, without duplication, for the following items:

- A. Completed and acceptable work executed in accordance with the contract documents prior to the effective date of termination, including fair and reasonable sums for overhead and profit on such work;
- B. Expenses sustained prior to the effective date of termination in performing services and furnishing labor, materials or equipment as required by the contract documents in connection with uncompleted work, plus fair and reasonable sums for overhead and profit on such expenses;
- C. All documented claims, costs, losses and damages incurred in settlement of terminated contracts with Subcontractors, Suppliers and others; and
- D. Reasonable expenses directly attributable to termination.

The Contractor shall not be paid on account of loss of anticipated profits or revenue or other economic loss arising out of or resulting from such termination.

13. INDEPENDENT CONTRACTOR

At all times, the Contractor, any of his/her employees, or his/her sub-contractors and their subsequent employees shall be considered independent contractors and not as City employees. The Contractor shall exercise all supervisory control and general control over all workers' duties, payment of wages to Contractor's employees and the right to hire, fire and discipline their employees and workers. As an independent contractor, payment under this contract shall not be subject to any withholding for tax, social security or other purposes, nor shall the Contractor or his/her employees be entitled to sick leave, pension benefit, vacation, medical benefits, life insurance or workers' unemployment compensation or the like.

14. PROJECT SUPERVISOR

The Contractor shall employ an individual to act as Project Supervisor. The Project Supervisor shall be available to the Contractor's workers and the Project Manager at all times by use of a mobile phone, beeper or other reliable means. The Project Supervisor shall prepare daily work plans for the employees, monitor employee performance, attendance and punctuality; and work closely with the City's Project Manager in assuring contract compliance.

15. MEETINGS

The Contractor and/or Project Supervisor shall be available to meet with the Department Head or Project Manager at a mutually agreeable time to discuss problems, issues or concerns relative to the contract. Either party may call a meeting at any time. When such a request for a meeting is made, the meeting date shall, in no case exceed five (5) working days after the request; and, if in the sole opinion of the Department Head, the severity of the circumstance warrants, no more than one (1) working day.

16. INSPECTION OF WORK SITE

Before submitting bids or quotes for work, the Contractor shall be responsible for examining the work site and satisfying himself/herself as to the existing conditions under which he/she will be obligated to operate, or that in any way affects the work under this contract. No allowance shall be made subsequently, in behalf of the Contractor, for any negligence on his/her part.

17. CONTRACT PERIOD, EXTENSIONS, CANCELLATION

- A. The contract shall be in effect for the term stated in the specifications.
- B. The City may opt to extend this contract upon mutual agreement of both parties. The number of extensions shall be limited to that stated in the specifications.
- C. The City may, from time to time, find it necessary to continue this contract on a month-to-month basis only, not to exceed a six (6) month period. Such month-to-month extended periods shall be by mutual agreement of both parties, with all provisions of the original contract or any extension thereof remaining in full force and effect.
- D. All contracts, extensions and cost increases are subject to availability of funds and the approval of the City Commission (if required).

CONTRACT PERIOD, EXTENSIONS, CANCELLATION (*cont.*)

- E. The City reserves the right to cancel the contract due to non-appropriation of funds by the City with thirty (30) days written notice.
- F. Either party may terminate the contract (or any extension thereof) without cause at the end of any twelve (12) month term by giving written notice of such intent at least 60 days prior to the end of said twelve (12) month term.
- G. All notices are in effect commencing with the date of mailing. Written notices may be delivered in person or sent by First Class mail; faxed or emailed to the last known address.
- H. If cancellation is for default of contract due to non-performance, the contract may be canceled at any time (see Item 11, DEFAULT)

APPENDIX A
NON-DISCRIMINATION CLAUSE FOR ALL CITY OF KALAMAZOO CONTRACTS

The Contractor agrees to comply with the Federal Civil Rights Act of 1964 as amended; the Federal Civil Rights Act of 1991 as amended; the Americans With Disabilities Act of 1990 as amended; the Elliott-Larson Civil Rights Act, Act. No. 453, Public Act of 1976 as amended; the Michigan Handicappers Civil Rights Act, Act No. 220, Public Act of 1976 as amended, City Ordinance 1856 and all other applicable Federal and State laws. The Contractor agrees as follows:

1. The Contractor will not discriminate against any employee or applicant for employment because of race, color, religion, national origin, sex, age, height, weight, marital status, physical or mental disability, family status, sexual orientation or gender identity that is unrelated to the individual's ability to perform the duties of the particular job or position. Such action shall include, but not be limited to the following: employment, upgrading, demotion or transfer, recruitment advertising, layoff or termination; rates of pay or other forms of compensations; and selection for training, including apprenticeship.
2. The Contractor will, in all solicitations or advertisements for employees placed by or on behalf of the Contractor, state that all qualified applicants will receive consideration for employment without regard to race, color, religion, national origin, sex, age, height, weight, marital status, physical or mental disability family status, sexual orientation or gender identity that is unrelated to the individual's ability to perform the duties of the particular job or position.
3. If requested by the City, the Contractor shall furnish information regarding practices, policies and programs and employment statistics for the Contractor and subcontractors. The Contractor and subcontractors shall permit access to all books, records and accounts regarding employment practices by agents and representatives of the City duly charged with investigative duties to assure compliance with this clause.
4. Breach of the covenants herein may be regarded as a material breach of the contract or purchasing agreement as provided in the Elliott-Larsen Civil Rights Act and City Ordinance 1856.
5. The Contractor will include or incorporate by reference the provisions of the foregoing paragraphs 1 through 4 in every subcontract or purchase order unless exempted by the rules, regulations or orders of the Michigan Civil Rights Commission* and will provide in every subcontract or purchase order that said provision will be binding upon each subcontractor or seller.
6. The Contractor will not preclude a person with a criminal conviction from being considered for employment unless otherwise precluded by federal or state law. (for contracts over \$25,000)

The Elliott-Larson Civil Rights Act, Sec. 202 of Act. No. 453 of 1976 reads in part as follows:

Sec. 202. (1) An employer shall not:

- (a) Fail or refuse to hire, or recruit, or discharge or otherwise discriminate against an individual with respect to employment, compensation, or a term condition or privilege of employment because of religion, race, color, national origin, age, sex, height, weight or marital status.
- (b) Limit, segregate or classify an employee or applicant for employment in a way which deprives or tends to deprive the employee or applicant of an employment opportunity or otherwise adversely affects the status of an employee or applicant because of religion, race, color, national origin, age, sex, height, weight or marital status.
- (c) Segregate, classify or otherwise discriminate against a person on the basis of sex with respect to a term, condition or privilege of employment, including a benefit plan or system.

* Except for contracts entered into with parties employing less than three employees.

APPENDIX B - PREVAILING WAGES

Prevailing wages are applicable to this contract, therefore, rates will apply as follows:

- (XX) Project is funded by City of Kalamazoo monies and is estimated to be in excess of \$100,000.00. The applicable prevailing wage rates are attached.

Specifications for projects in which the City of Kalamazoo is party for construction, alterations and/or repair including painting and decorating of public buildings or public works in or for the City of Kalamazoo and which requires or involves the employment of mechanics and/or laborers shall contain the following provisions stating the minimum wages to be paid the various classes of laborers and mechanics for the project. Prevailing wage rates determined by the U.S. Department of Labor under Davis Bacon and related acts will be used for City of Kalamazoo construction projects.

By the incorporation of prevailing wage rates within this specification, the City of Kalamazoo stipulates that:

- ✓ Contractor or his/her subcontractor shall pay all mechanics and laborers employed directly upon the site of the work, unconditionally and not less than once a week and without subsequent deduction or rebate on any account the full amount, accrued at the time of payment, computed at wage rates as incorporated herein regardless of any contractual relationship which may be alleged to exist between the contractor or subcontractor and such laborers and mechanics;
- ✓ The scale of wages to be paid shall be posted by the contractor in a prominent and easily accessible place at the site of the work;
- ✓ The Prime Contractor and all subcontractors shall submit weekly certified payrolls documenting the hours worked and wages paid by work classification. **NOTE: Contactor shall not include Social Security numbers of employees on certified payrolls.**
- ✓ There may be withheld from the contractor's accrued payments the amount considered necessary by the City's Contracting Official to pay to laborers and mechanics employed by the contractor or any subcontractor on the work for the difference between the rates of wages required by the contract and the rates of wages received by such laborers and mechanics except those amounts properly deducted or refunded pursuant to the terms of the Davis-Bacon Act (USC, Title 40, Sec. 276a) and interpretations thereof.

Special Note: The City's requirements as it relates to prevailing wages **includes a meeting with the City's Purchasing Agent prior to starting work and the submission of weekly certified payrolls by prime contractors and all subcontractors.** The City will monitor certified payrolls, work progress, and conduct interviews with the mechanics and labors employed directly upon the site during the duration of the contract Please contact the Purchasing Department at (269) 337-8020 if you have any questions regarding prevailing wage provision.

The overtime pay to which a laborer or mechanic is entitled under this contract shall be that overtime pay to which he/she is entitled by any agreement made with the contractor or subcontractor or by any applicable provision of law; but in no event shall such amount be less than the prevailing wage in the Kalamazoo community for such overtime.

Revised 4-08



PREVAILING WAGE RATES

**2023 WATER MAIN BREAK ROAD PATCH
REPLACEMENT**

Bid Reference #: 91395-007.0

July 2023

"General Decision Number: MI20230001 05/26/2023

Superseded General Decision Number: MI20220001

State: Michigan

Construction Types: Highway (Highway, Airport & Bridge xxxxx and Sewer/Incid. to Hwy.)

Counties: Michigan Statewide.

Note: Contracts subject to the Davis-Bacon Act are generally required to pay at least the applicable minimum wage rate required under Executive Order 14026 or Executive Order 13658. Please note that these Executive Orders apply to covered contracts entered into by the federal government that are subject to the Davis-Bacon Act itself, but do not apply to contracts subject only to the Davis-Bacon Related Acts, including those set forth at 29 CFR 5.1(a)(2)-(60).

<p>If the contract is entered into on or after January 30, 2022, or the contract is renewed or extended (e.g., an option is exercised) on or after January 30, 2022:</p>	<ul style="list-style-type: none"> . Executive Order 14026 generally applies to the contract. . The contractor must pay all covered workers at least \$16.20 per hour (or the applicable wage rate listed on this wage determination, if it is higher) for all hours spent performing on the contract in 2023.
<p>If the contract was awarded on or between January 1, 2015 and January 29, 2022, and the contract is not renewed or extended on or after January 30, 2022:</p>	<ul style="list-style-type: none"> . Executive Order 13658 generally applies to the contract. . The contractor must pay all covered workers at least \$12.15 per hour (or the applicable wage rate listed on this wage determination, if it is higher) for all hours spent performing on that contract in 2023.

The applicable Executive Order minimum wage rate will be adjusted annually. If this contract is covered by one of the Executive Orders and a classification considered necessary for performance of work on the contract does not appear on this wage determination, the contractor must still submit a conformance request.

Additional information on contractor requirements and worker protections under the Executive Orders is available at <http://www.dol.gov/whd/govcontracts>.

Modification Number	Publication Date
0	01/06/2023
1	02/03/2023
2	02/17/2023

3	03/17/2023
4	05/12/2023
5	05/19/2023
6	05/26/2023

CARP0004-004 06/01/2019

REMAINDER OF STATE

	Rates	Fringes
CARPENTER (Piledriver).....	\$ 27.62	20.59

CARP0004-005 06/01/2018

LIVINGSTON (Townships of Brighton, Deerfield, Genoa, Hartland, Oceola & Tyrone), MACOMB, MONROE, OAKLAND, SANILAC, ST. CLAIR AND WAYNE COUNTIES

	Rates	Fringes
CARPENTER (Piledriver).....	\$ 30.50	27.28

ELEC0017-005 06/01/2022

STATEWIDE

	Rates	Fringes
Line Construction		
Groundman/Driver.....	\$ 29.57	7.20+32%
Journeyman Signal Tech, Communications Tech, Tower Tech & Fiber Optic Splicers.	\$ 43.90	7.20+32%
Journeyman Specialist.....	\$ 50.49	7.20+32%
Operator A.....	\$ 37.13	7.20+32%
Operator B.....	\$ 34.67	7.20+32%

Classifications

Journeyman Specialist: Refers to a crew of only one person working alone.
Operator A: Shall be proficient in operating all power equipment including: Backhoe, Excavator, Directional Bore and Boom/Digger truck.
Operator B: Shall be proficient in operating any 2 of the above mentioned pieces of equipment listed under Operator A.

ENGI0324-003 06/01/2022

ALCONA, ALPENA, ARENAC, BAY, CHEBOYGAN, CLARE, CLINTON, CRAWFORD, GENESEE, GLADWIN, GRATIOT, HURON, INGHAM, IOSCO, ISABELLA, JACKSON, LAPEER, LENAWEE, LIVINGSTON, MACOMB, MIDLAND, MONROE, MONTMORENCY, OAKLAND, OGEMAW, OSCODA, OTSEGO, PRESQUE ISLE, ROSCOMMON, SAGINAW, ST. CLAIR, SANILAC, SHIAWASSEE, TUSCOLA, WASHTENAW AND WAYNE COUNTIES:

	Rates	Fringes
OPERATOR: Power Equipment (Steel Erection)		

GROUP 1.....	\$ 51.02	24.85
GROUP 2.....	\$ 52.02	24.85
GROUP 3.....	\$ 49.52	24.85
GROUP 4.....	\$ 50.52	24.85
GROUP 5.....	\$ 48.02	24.85
GROUP 6.....	\$ 49.02	24.85
GROUP 7.....	\$ 47.75	24.85
GROUP 8.....	\$ 48.75	24.85
GROUP 9.....	\$ 47.30	24.85
GROUP 10.....	\$ 48.30	24.85
GROUP 11.....	\$ 46.57	24.85
GROUP 12.....	\$ 47.57	24.85
GROUP 13.....	\$ 46.21	24.85
GROUP 14.....	\$ 47.21	24.85
GROUP 15.....	\$ 45.57	24.85
GROUP 16.....	\$ 42.37	24.85
GROUP 17.....	\$ 27.89	12.00
GROUP 18.....	\$ 31.38	24.85

FOOTNOTE:

Paid Holidays: New Year's Day, Memorial Day, Fourth of July, Labor Day, Thanksgiving Day and Christmas Day.

POWER EQUIPMENT OPERATOR CLASSIFICATIONS

GROUP 1: Engineer when operating combination of boom and jib 400' or longer

GROUP 2: Engineer when operating combination of boom and jib 400' or longer on a crane that requires an oiler

GROUP 3: Engineer when operating combination of boom and jib 300' or longer

GROUP 4: Engineer when operating combination of boom and jib 300' or longer on a crane that requires an oiler

GROUP 5: Engineer when operating combination of boom and jib 220' or longer

GROUP 6: Engineer when operating combination of boom and jib 220' or longer on a crane that requires an oiler

GROUP 7: Engineer when operating combination of boom and jib 140' or longer

GROUP 8: Engineer when operating combination of boom and jib 140' or longer on a crane that requires an oiler

GROUP 9: Tower crane & derrick operator (where operator's work station is 50 ft. or more above first sub-level)

GROUP 10: Tower crane & derrick operator (where operator's work station is 50 ft. or more above first sub-level) on a crane that requires an oiler

GROUP 11: Engineer when operating combination of boom and jib 120' or longer

GROUP 12: Engineer when operating combination of boom and jib 120' or longer on a crane that requires an oiler

GROUP 13: Crane operator; job mechanic and 3 drum hoist and excavator

GROUP 14: Crane operator on a crane that requires an oiler

GROUP 15: Hoisting operator; 2 drum hoist and rubber tired backhoe

GROUP 16: Forklift and 1 drum hoist

GROUP 17: Compressor or welder operator

GROUP 18: Oiler

ENGI0324-004 06/01/2022

AREA 1: ALLEGAN, BARRY, BERRIEN, BRANCH, CALHOUN, CASS, EATON, HILLSDALE, IONIA, KALAMAZOO, KENT, LAKE, MANISTEE, MASON, MECOSTA, MONTCALM, MUSKEGON, NEWAYGO, OCEANA, OSCEOLA, OTTAWA, ST. JOSEPH, VAN BUREN

AREA 2: ANTRIM, BENZIE, CHARLEVOIX, EMMET, GRAND TRAVERSE, KALKASKA, LEELANAU, MISSAUKEE AND WEXFORD COUNTIES:

Rates Fringes

OPERATOR: Power Equipment
(Steel Erection)

	Rates	Fringes
AREA 1		
GROUP 1.....	\$ 51.02	24.85
GROUP 2.....	\$ 47.75	24.85
GROUP 3.....	\$ 46.21	24.85
GROUP 4.....	\$ 42.37	24.85
GROUP 5.....	\$ 27.89	12.00
GROUP 6.....	\$ 31.38	24.85
AREA 2		
GROUP 1.....	\$ 51.02	24.85
GROUP 2.....	\$ 47.75	24.85
GROUP 3.....	\$ 46.21	24.85
GROUP 4.....	\$ 42.37	24.85
GROUP 5.....	\$ 27.89	12.00
GROUP 6.....	\$ 31.38	24.85

FOOTNOTES:

Crane operator with main boom and jib 300' or longer: \$1.50 additional to the group 1 rate. Crane operator with main boom and jib 400' or longer: \$3.00 additional to the group 1 rate.

PAID HOLIDAYS: New Year's Day, Memorial Day, Fourth of July, Labor Day, Thanksgiving Day and Christmas Day.

POWER EQUIPMENT OPERATOR CLASSIFICATIONS:

GROUP 1: Crane Operator with main boom & jib 400', 300', or 220' or longer.

GROUP 2: Crane Operator with main boom & jib 140' or longer, Tower Crane; Gantry Crane; Whirley Derrick.

GROUP 3: Regular Equipment Operator, Crane, Dozer, Loader, Hoist, Straddle Wagon, Mechanic, Grader and Hydro Excavator.

GROUP 4: Air Tugger (single drum), Material Hoist Pump 6" or over, Elevators, Brokk Concrete Breaker.

GROUP 5: Air Compressor, Welder, Generators, Conveyors

GROUP 6: Oiler and fire tender

 ENGI0324-005 09/01/2022

AREA 1: GENESEE, LAPEER, LIVINGSTON, MACOMB, MONROE, OAKLAND, ST. CLAIR, WASHTENAW AND WAYNE COUNTIES

AREA 2: ALCONA, ALLEGAN, ALGER, ALPENA, ANTRIM, ARENAC, BARAGA, BARRY, BAY, BENZIE, BERRIEN, BRANCH, CALHOUN, CASS, CHARLEVOIX, CHEBOYGAN, CHIPPEWA, CLARE, CLINTON, CRAWFORD, DELTA, DICKINSON, EATON, EMMET, GLADWIN, GOGEBIC, GRAND TRAVERSE, GRATIOT, HILLSDALE, HOUGHTON, HURON, INGHAM, IONIA, IOSCO, IRON, ISABELLA, JACKSON, KALAMAZOO, KALKASKA, KENT, KWEENAW, LAKE, LEELANAU, LENAWEE, LUCE, MACKINAC, MANISTEE, MARQUETTE, MASON, MECOSTA, MENOMINEE, MIDLAND, MISSAUKEE, MONTCALM, MONTMORENCY, MUSKEGON, NEWAYGO, OCEANA, OGEMAW, ONTONAGON, OSCEOLA, OSCODA, OTSEGO, OTTAWA, PRESQUE ISLE, ROSCOMMON, SAGINAW, SANILAC, SCHOOLCRAFT, SHIAWASSEE, ST. JOSEPH, TUSCOLA, VAN BUREN AND WEXFORD COUNTIES

Rates Fringes

OPERATOR: Power Equipment
 (Underground construction
 (including sewer))

AREA 1:		
GROUP 1.....	\$ 39.38	24.85
GROUP 2.....	\$ 34.65	24.85
GROUP 3.....	\$ 33.92	24.85
GROUP 4.....	\$ 33.35	24.85
GROUP 5.....	\$ 24.90	12.05
AREA 2:		
GROUP 1.....	\$ 37.67	24.85
GROUP 2.....	\$ 32.78	24.85
GROUP 3.....	\$ 32.28	24.85
GROUP 4.....	\$ 32.00	24.85
GROUP 5.....	\$ 24.90	12.05

POWER EQUIPMENT OPERATOR CLASSIFICATIONS

GROUP 1: Backfiller tamper; Backhoe; Batch plant operator (concrete); Clamshell; Concrete paver (2 drums or larger); Conveyor loader (Euclid type); Crane (crawler, truck type or pile driving); Dozer; Dragline; Elevating grader; Endloader; Gradall (and similar type machine); Grader; Mechanic; Power shovel; Roller (asphalt); Scraper (self-propelled or tractor drawn); Side boom tractor (type D-4 or equivalent and larger); Slip form paver; Slope paver; Trencher (over 8 ft. digging capacity); Well drilling rig; Concrete pump with boom operator; Hydro Excavator

GROUP 2: Boom truck (power swing type boom); Crusher; Hoist; Pump (1 or more - 6-in. discharge or larger - gas or diesel- powered or powered by generator of 300 amperes or more - inclusive of generator); Side boom tractor (smaller than type D-4 or equivalent); Tractor (pneu-tired, other than backhoe or front end loader); Trencher (8-ft. digging capacity and smaller); Vac Truck and End dump operator;

GROUP 3: Air compressors (600 cfm or larger); Air compressors (2 or more-less than 600 cfm); Boom truck (non-swinging, non-powered type boom); Concrete breaker (self-propelled or truck mounted - includes compressor); Concrete paver (1 drum-1/2 yd. or larger); Elevator (other than passenger); Maintenance person; Pump (2 or more-4-in. up to 6-in. discharge-gas or diesel powered - excluding submersible pumps); Pumpcrete machine (and similar equipment); Wagon drill (multiple); Welding machine or generator (2 or more-300 amp. or larger - gas or diesel powered)

GROUP 4: Boiler; Concrete saw (40 hp or over); Curing machine (self-propelled); Farm tractor (with attachment); Finishing machine (concrete); Hydraulic pipe pushing machine; Mulching equipment; Pumps (2 or more up to 4-in. discharge, if used 3 hours or more a day, gas or diesel powered - excluding submersible pumps); Roller (other than asphalt); Stump remover; Trencher (service); Vibrating compaction equipment, self-propelled (6 ft. wide or over); Sweeper (Wayne type); Water wagon and Extend-a boom forklift

Group 5: Fire Person, Oiler

 * ENGI0324-006 06/01/2022

GENESEE, MACOMB, MONROE, OAKLAND, WASHTENAW, WAYNE, ALCONA, ALGER, ALLEGAN, ALPENA, ANTRIM, ARENAC, BARAGA, BARRY, BAY, BENZIE, BERRIEN, BRANCH, CALHOUN, CASS, CHARLEVOIX, CHEBOYGAN, CHIPPEWA, CLARE, CLINTON, CRAWFORD, DELTA, DICKINSON, EATON, EMMET, GLADWIN, GOGEBIC, GRAND TRAVERSE, GRATIOT, HILLSDALE, HOUGHTON, HURON, INGHAM, IONIA, IOSCO, IRON, ISABELLA, JACKSON, KALAMAZOO, KALKASKA, KENT, KEWEENAW, LAKE, LAPEER, LEELANAU, LENAWEE, LIVINGSTON, LUCE, MACKINAC, MANISTEE, MARQUETTE, MASON, MECOSTA, MENOMINEE, MIDLAND, MISSAUKEE, MONTCALM, MONTMORENCY, MUSKEGON, NEWAYGO, OCEANA, OGEMAW, ONTONAGON, OSCEOLA, OSCODA, OTSEGO, OTTAWA, PRESQUE ISLE, ROSCOMMON, SAGINAW, ST. CLARE, ST. JOSEPH, SANILAC, SCHOOLCRAFT, SHIAWASSEE, TUSCOLA, VAN BUREN AND WEXFORD COUNTIES

Rates Fringes

Power equipment operators:
 (AIRPORT, BRIDGE & HIGHWAY
 CONSTRUCTION)

GROUP 1.....	\$ 38.86	24.85
GROUP 2.....	\$ 32.13	24.85
GROUP 3.....	\$ 31.57	24.85
GROUP 4.....	\$ 31.40	24.85

POWER EQUIPMENT OPERATOR CLASSIFICATIONS

GROUP 1: Asphalt plant operator; Crane operator (does not include work on bridge construction projects when the crane operator is erecting structural components); Dragline operator; Shovel operator; Locomotive operator; Paver operator (5 bags or more); Elevating grader operator; Pile driving operator; Roller operator (asphalt); Blade grader operator; Trenching machine operator (ladder or wheel type); Auto-grader; Slip form paver; Self-propelled or tractor-drawn scraper; Conveyor loader operator (Euclid type); Endloader operator (1 yd. capacity and over); Bulldozer; Hoisting engineer; Tractor operator; Finishing machine operator (asphalt); Mechanic; Pump operator (6-in.

discharge or over, gas, diesel powered or generator of 300 amp. or larger); Shouldering or gravel distributing machine operator (self-propelled); Backhoe (with over 3/8 yd. bucket); Side boom tractor (type D-4 or equivalent or larger); Tube finisher (slip form paving); Gradall (and similar type machine); Asphalt paver (self-propelled); Asphalt planer (self-propelled); Batch plant (concrete-central mix); Slurry machine (asphalt); Concrete pump (3 in. and over); Roto-mill; Swinging boom truck (over 12 ton capacity); Hydro demolisher (water blaster); Farm-type tractor with attached pan; Vacuum truck operator; Batch Plant (concrete dry batch); Concrete Saw Operator (40h.p. or over; Tractor Operator (farm type); Finishing Machine Operator (concrete); Grader Operator (self-propelled fine grade or form (concrete)).

GROUP 2: Screening plant operator; Washing plant operator; Crusher operator; Backhoe (with 3/8 yd. bucket or less); Side boom tractor (smaller than D-4 type or equivalent); Sweeper (Wayne type and similar equipment); Greese Truck; Air Compressor Operator (600 cu.ft. per min or more); Air Compressor Operator (two or more, less than 600 cfm);

GROUP 3: Boiler fire tender; Tractor operator (farm type with attachment); Concrete Breaker; Wagon Drill Operator;

GROUP 4: Oiler; Fire tender; Trencher (service); Flexplane operator; Cleftplane operator; Boom or winch hoist truck operator; Endloader operator *under 1 yd. capacity); Roller Operator (other than asphalt); Curing equipment operator (self-propelled); Power bin operator; Plant drier (6 ft. wide or over); Guard post driver operator (power driven); All mulching equipment; Stump remover; Concrete pump (under 3-in.); Mesh installer (self-propelled); End dump; Skid Steer.

 * ENGI0324-007 05/01/2023

ALGER, BARAGA, CHIPPEWA, DELTA, DICKINSON, GOGEBIC, HOUGHTON, IRON, KEWEENAW, LUCE, MACKINAC MARQUETTE, MENOMINEE, ONTONAGON AND SCHOOLCRAFT COUNTIES:

	Rates	Fringes
OPERATOR: Power Equipment (Steel Erection)		
Compressor, welder and forklift.....	\$ 38.50	25.00
Crane operator, main boom & jib 120' or longer.....	\$ 44.97	25.00
Crane operator, main boom & jib 140' or longer.....	\$ 44.17	24.60
Crane operator, main boom & jib 220' or longer.....	\$ 45.27	25.00
Mechanic with truck and tools.....	\$ 44.10	25.00
Oiler and fireman.....	\$ 39.96	25.00
Regular operator.....	\$ 42.32	25.00

 ENGI0324-008 10/01/2022

ALCONA, ALGER, ALLEGAN, ALPENA, ANTRIM, ARENAC, BARAGA, BARRY, BAY, BENZIE, BERRIEN, BRANCH, CALHOUN, CASS, CHARLEVOIX,

CHEBOYGAN, CHIPPEWA, CLARE, CLINTON, CRAWFORD, DELTA, DICKINSON, EATON, EMMET, GENESEE, GLADWIN, GOGEBIC, GRAND TRAVERSE, GRATIOT, HILLSDALE, HOUGHTON, HURON, INGHAM, IONIA, IOSCO, IRON, ISABELLA, JACKSON, KALAMAZOO, KALKASKA, KENT, KEWEENAW, LAKE, LAPEER, LEELANAU, LENAWEE, LIVINGSTON, LUCE, MACKINAC, MACOMB, MANISTEE, MARQUETTE, MASON, MECOSTA, MENOMINEE, MIDLAND, MISSAUKEE, MONTCALM, MONTMORENCY, MONROE, MUSKEGON, NEWAYGO, OAKLAND, OCEANA, OGEMAW, ONTONAGON, OSCEOLA, OSCODA, OTSEGO, OTTAWA, PRESQUE ISLE, ROSCOMMON, SAGINAW, ST. CLARE, ST. JOSEPH, SANILAC, SCHOOLCRAFT, SHIAWASSEE, TUSCOLA, VAN BUREN, WASHTENAW, WAYNE AND WEXFORD COUNTIES

Rates Fringes

OPERATOR: Power Equipment
(Sewer Relining)

GROUP 1.....	\$ 35.37	14.77
GROUP 2.....	\$ 33.33	14.77

SEWER RELINING CLASSIFICATIONS

GROUP 1: Operation of audio-visual closed circuit TV system, including remote in-ground cutter and other equipment used in connection with the CCTV system

GROUP 2: Operation of hot water heaters and circulation systems, water jetters and vacuum and mechanical debris removal systems

ENGI0325-012 05/01/2023

Rates Fringes

Power equipment operators -
gas distribution and duct
installation work:

GROUP 1.....	\$ 36.18	25.25
GROUP 2.....	\$ 33.45	25.25

SCOPE OF WORK: The construction, installation, treating and reconditioning of pipelines transporting gas vapors within cities, towns, subdivisions, suburban areas, or within private property boundaries, up to and including private meter settings of private industrial, governmental or other premises, more commonly referred to as ""distribution work,"" starting from the first metering station, connection, similar or related facility, of the main or cross country pipeline and including duct installation.

Group 1: Backhoe, crane, grader, mechanic, dozer (D-6 equivalent or larger), side boom (D-4 equivalent or larger), trencher(except service), endloader (2 yd. capacity or greater).

GROUP 2: Dozer (less than D-6 equivalent), endloader (under 2 yd. capacity), side boom (under D-4 capacity), backfiller, pumps (1 or 2 of 6-inch discharge or greater), boom truck (with powered boom), tractor (wheel type other than backhoe or front endloader). Tamper (self-propelled), boom truck (with non-powered boom), concrete saw (20 hp or larger), pumps (2 to 4 under 6-inch discharge), compressor (2 or more or when one is used continuously into the second day) and trencher(service). Oiler, hydraulic pipe pushing

machine, grease person and hydrostatic testing operator.

IRON0008-007 06/01/2022

ALGER, BARAGA, CHIPPEWA, DELTA, DICKINSON, GOGEBIC, HOUGHTON,
IRON, KEWEENAW, LUCE, MACKINAC MARQUETTE, MENOMINEE, ONTONAGON
AND SCHOOLCRAFT COUNTIES:

	Rates	Fringes
Ironworker - pre-engineered metal building erector.....	\$ 23.70	6.95
IRONWORKER		
General contracts \$10,000,000 or greater.....	\$ 38.14	28.70
General contracts less than \$10,000,000.....	\$ 38.14	28.70

Paid Holidays: New Year's Day, Memorial Day, July 4th, Labor
Day, Thanksgiving Day & Christmas Day.

IRON0025-002 06/01/2022

ALCONA, ALPENA, ARENAC, BAY, CHEBOYGAN, CLARE, CLINTON,
CRAWFORD, GENESEE, GLADWIN, GRATIOT, HURON, INGHAM, IOSCO,
ISABELLA, JACKSON, LAPEER, LIVINGSTON, MACOMB, MIDLAND,
MONTMORENCY, OAKLAND, OGEMAW, OSCODA, OTSEGO, PRESQUE ISLE,
ROSCOMMON, SAGINAW, SANILAC, SHIAWASSEE, ST. CLAIR, TUSCOLA,
WASHTENAW AND WAYNE COUNTIES:

	Rates	Fringes
Ironworker - pre-engineered metal building erector		
ALLEGAN, ANTRIM, BARRY, BENZIE, BRANCH, CALHOUN, CHARLEVOIX, EATON, EMMET, GRAND TRAVERSE, HILLSDALE, IONIA, KALAMAZOO, KALKASKA, KENT, LAKE, LEELANAU, MANISTEE, MASON, MECOSTA, MISSAUKEE, MONTCALM, MUSKEGON, NEWAYGO, OCEANA, OSCEOLA, OTTAWA, ST. JOSEPH, VAN BUREN AND WEXFORD COUNTIES:..	\$ 24.59	25.43
Bay, Genesee, Lapeer, Livingston (east of Burkhardt Road), Macomb, Midland, Oakland, Saginaw, St. Clair, The University of Michigan, Washtenaw (east of U.S. 23) & Wayne...	\$ 25.81	26.43
IRONWORKER		
Ornamental and Structural...	\$ 34.50	38.44
Reinforcing.....	\$ 31.43	34.77

IRON0055-005 07/01/2022

LENAWEE AND MONROE COUNTIES:

	Rates	Fringes
IRONWORKER		
Pre-engineered metal buildings.....	\$ 23.59	19.35
All other work.....	\$ 33.00	27.20

IRON0292-003 06/01/2020

BERRIEN AND CASS COUNTIES:

	Rates	Fringes
IRONWORKER (Including pre-engineered metal building erector).....		
	\$ 31.75	22.84

LAB00005-006 10/01/2022

	Rates	Fringes
Laborers - hazardous waste abatement: (ALCONA, ALPENA, ANTRIM, BENZIE, CHARLEVOIX, CHEBOYGAN, CRAWFORD, EMMET, GRAND TRAVERSE, IOSCO, KALKASKA, LEELANAU, MISSAUKEE, MONTMORENCY, OSCODA, OTSEGO, PRESQUE ISLE AND WEXFORD COUNTIES - Zone 10)		
Levels A, B or C.....	\$ 17.45	12.75
class b.....	\$ 18.64	12.90
Work performed in conjunction with site preparation not requiring the use of personal protective equipment;		
Also, Level D.....	\$ 16.45	12.75
class a.....	\$ 17.64	12.90

Zone 10

Laborers - hazardous waste abatement: (ALGER, BARAGA, CHIPPEWA, DELTA, DICKINSON, GOGEBIC, HOUGHTON, IRON, KEWEENAW, LUCE, MACKINAC, MARQUETTE, MENOMINEE, ONTONAGON AND SCHOOLCRAFT COUNTIES - Zone 11)		
Levels A, B or C.....	\$ 25.18	12.90
Work performed in conjunction with site preparation not requiring the use of personal protective equipment;		
Also, Level D.....	\$ 22.58	12.90

Laborers - hazardous waste abatement: (ALLEGAN, BARRY, BERRIEN, BRANCH, CALHOUN, CASS, IONIA COUNTY (except the city of Portland); KALAMAZOO, KENT, LAKE, MANISTEE, MASON, MECOSTA, MONTCALM, MUSKEGON, NEWAYGO, OCEANA, OSCEOLA, OTTAWA, ST.		
---	--	--

JOSEPH AND VAN BUREN COUNTIES

- Zone 9)

Levels A, B or C.....\$ 21.88 13.26

Work performed in
conjunction with site
preparation not requiring
the use of personal
protective equipment;

Also, Level D.....\$ 20.80 12.90

Laborers - hazardous waste

abatement: (ARENAC, BAY,
CLARE, GLADWIN, GRATIOT,
HURON, ISABELLA, MIDLAND,
OGEMAW, ROSCOMMON, SAGINAW

AND TUSCOLA COUNTIES - Zone 8)

Levels A, B or C.....\$ 23.74 12.95

Work performed in
conjunction with site
preparation not requiring
the use of personal
protective equipment;

Also, Level D.....\$ 20.80 12.90

Laborers - hazardous waste

abatement: (CLINTON, EATON
AND INGHAM COUNTIES; IONIA
COUNTY (City of Portland);
LIVINGSTON COUNTY (west ofOak Grove Rd., including the
City of Howell) - Zone 6)

Levels A, B or C.....\$ 26.33 12.95

Work performed in
conjunction with site
preparation not requiring
the use of personal
protective equipment;

Also, Level D.....\$ 24.64 12.90

Laborers - hazardous waste

abatement: (GENESEE, LAPEER
AND SHIAWASSEE COUNTIES -

Zone 7)

Levels A, B or C.....\$ 24.20 13.80

Work performed in
conjunction with site
preparation not requiring
the use of personal
protective equipment;

Also, Level D.....\$ 23.20 13.80

Laborers - hazardous waste

abatement: (HILLSDALE,
JACKSON AND LENAWEЕ COUNTIES

- Zone 4)

Levels A, B or C.....\$ 27.13 14.95

Work performed in
conjunction with site
preparation not requiring
the use of personal
protective equipment;

Also, Level D.....\$ 24.17 12.90

Laborers - hazardous waste

abatement: (LIVINGSTON COUNTY
(east of Oak Grove Rd. and
south of M-59, excluding the
city of Howell); AND

WASHTENAW COUNTY - Zone 3)

Levels A, B or C.....\$ 29.93 14.20

Work performed in conjunction with site preparation not requiring the use of personal protective equipment;		
Also, Level D.....	\$ 28.93	14.20
Laborers - hazardous waste abatement: (MACOMB AND WAYNE COUNTIES - Zone 1)		
Levels A, B or C.....	\$ 29.93	16.90
Work performed in conjunction with site preparation not requiring the use of personal protective equipment;		
Also, Level D.....	\$ 28.93	16.90
Laborers - hazardous waste abatement: (MONROE COUNTY - Zone 4)		
Levels A, B or C.....	\$ 31.75	14.90
Work performed in conjunction with site preparation not requiring the use of personal protective equipment;		
Also, Level D.....	\$ 31.75	14.90
Laborers - hazardous waste abatement: (OAKLAND COUNTY and the Northeast portion of LIVINGSTON COUNTY bordered by Oak Grove Road on the West and M-59 on the South - Zone 2)		
Level A, B, C.....	\$ 29.93	16.90
Work performed in conjunction with site preparation not requiring the use of personal protective equipment;		
Also, Level D.....	\$ 28.93	16.90
Laborers - hazardous waste abatement: (SANILAC AND ST. CLAIR COUNTIES - Zone 5)		
Levels A, B or C.....	\$ 26.21	16.62
Work performed in conjunction with site preparation not requiring the use of personal protective equipment;		
Also, Level D.....	\$ 24.75	16.35

LAB00259-001 09/01/2022

AREA 1: MACOMB, OAKLAND AND WAYNE COUNTIES
 AREA 2: ALCONA, ALGER, ALLEGAN, ALPENA, ANTRIM, ARENAC, BARAGA, BARRY, BAY, BENZIE, BERRIEN, BRANCH, CALHOUN, CASS, CHARLEVOIX, CHEBOYGAN, CHIPPEWA, CLARE, CLINTON, CRAWFORD, DELTA, DICKINSON, EATON, EMMET, GENESEE, GLADWIN, GOGEBIC, GRAND TRAVERSE, GRATIOT, HILLSDALE, HOUGHTON, HURON, INGHAM, IONIA, IOSCO, IRON, ISABELLA, JACKSON, KALAMAZOO, KALKASKA, KENT, KEWEENAW, LAKE, LAPEER, LEELANAU, LENAWEE, LIVINGSTON, LUCE, MACKINAC, MANISTEE, MARQUETTE, MASON, MECOSTA, MENOMINEE, MIDLAND, MISSAUKEE, MONROE, MONTCALM, MONTMORENCY, MUSKEGON, NEWAYGO, OCEANA, OGEMAW, ONTONAGON, OSCEOLA, OSCODA, OTSEGO, OTTAWA, PRESQUE ISLE, ROSCOMMON, SAGINAW, ST. CLARE, ST.

JOSEPH, SANILAC, SCHOOLCRAFT, SHIAWASSEE, TUSCOLA, VAN BUREN,
 WASHTENAW AND WEXFORD COUNTIES

	Rates	Fringes
Laborers - tunnel, shaft and caisson:		
AREA 1		
GROUP 1.....	\$ 23.62	16.95
GROUP 2.....	\$ 23.73	19.95
GROUP 3.....	\$ 23.79	16.95
GROUP 4.....	\$ 23.97	16.95
GROUP 5.....	\$ 24.22	16.95
GROUP 6.....	\$ 24.55	16.95
GROUP 7.....	\$ 17.83	16.95
AREA 2		
GROUP 1.....	\$ 25.15	12.95
GROUP 2.....	\$ 25.24	12.95
GROUP 3.....	\$ 25.34	12.95
GROUP 4.....	\$ 25.50	12.95
GROUP 5.....	\$ 25.76	12.95
GROUP 6.....	\$ 26.07	12.95
GROUP 7.....	\$ 18.34	12.95

SCOPE OF WORK: Tunnel, shaft and caisson work of every type and description and all operations incidental thereto, including, but not limited to, shafts and tunnels for sewers, water, subways, transportation, diversion, sewerage, caverns, shelters, aquifers, reservoirs, missile silos and steel sheeting for underground construction.

TUNNEL LABORER CLASSIFICATIONS

GROUP 1: Tunnel, shaft and caisson laborer, dump, shanty, hog house tender, testing (on gas) and watchman

GROUP 2: Manhole, headwall, catch basin builder, bricklayer tender, mortar machine and material mixer

GROUP 3: Air tool operator (jackhammer, bush hammer and grinder), first bottom, second bottom, cage tender, car pusher, carrier, concrete, concrete form, concrete repair, cement invert laborer, cement finisher, concrete shoveler, conveyor, floor, gasoline and electric tool operator, gunite, grout operator, welder, heading dinky person, inside lock tender, pea gravel operator, pump, outside lock tender, scaffold, top signal person, switch person, track, tugger, utility person, vibrator, winch operator, pipe jacking, wagon drill and air track operator and concrete saw operator (under 40 h.p.)

GROUP 4: Tunnel, shaft and caisson mucker, bracer, liner plate, long haul dinky driver and well point

GROUP 5: Tunnel, shaft and caisson miner, drill runner, key board operator, power knife operator, reinforced steel or mesh (e.g. wire mesh, steel mats, dowel bars, etc.)

GROUP 6: Dynamite and powder

GROUP 7: Restoration laborer, seeding, sodding, planting, cutting, mulching and top soil grading; and the restoration of property such as replacing mailboxes, wood chips, planter boxes, flagstones, etc.

 LAB00334-001 09/01/2022

Rates Fringes

Laborers - open cut:

ZONE 1 - MACOMB, OAKLAND
 AND WAYNE COUNTIES:

GROUP 1.....	\$ 23.47	16.72
GROUP 2.....	\$ 23.58	16.72
GROUP 3.....	\$ 23.63	16.72
GROUP 4.....	\$ 23.71	16.72
GROUP 5.....	\$ 24.17	16.72
GROUP 6.....	\$ 22.00	16.72
GROUP 7.....	\$ 17.84	16.72

ZONE 2 - LIVINGSTON COUNTY
 (east of M-151 (Oak Grove
 Rd.)); MONROE AND

WASHTENAW COUNTIES:

GROUP 1.....	\$ 25.20	16.72
GROUP 2.....	\$ 24.91	16.72
GROUP 3.....	\$ 25.03	16.72
GROUP 4.....	\$ 25.10	16.72
GROUP 5.....	\$ 25.25	16.72
GROUP 6.....	\$ 22.55	16.72
GROUP 7.....	\$ 22.11	16.72

ZONE 3 - CLINTON, EATON,
 GENESEE, HILLSDALE AND
 INGHAM COUNTIES; IONIA
 COUNTY (City of Portland);
 JACKSON, LAPEER AND
 LENAWEЕ COUNTIES;

LIVINGSTON COUNTY (west of
 M-151 Oak Grove Rd.);

SANILAC, ST. CLAIR AND

SHIAWASSEE COUNTIES:

GROUP 1.....	\$ 23.39	16.72
GROUP 2.....	\$ 23.13	16.72
GROUP 3.....	\$ 23.25	16.72
GROUP 4.....	\$ 23.30	16.72
GROUP 5.....	\$ 23.44	16.72
GROUP 6.....	\$ 20.74	16.72
GROUP 7.....	\$ 22.23	16.72

ZONE 4 - ALCONA, ALLEGAN,
 ALPENA, ANTRIM, ARENAC,
 BARRY, BAY, BENZIE,
 BERRIEN, BRANCH,
 CALHOUN, CASS, CHARLEVOIX,
 CHEBOYGAN, CLARE,
 CRAWFORD, EMMET,
 GLADWIN, GRAND TRAVERSE,
 GRATIOT AND HURON
 COUNTIES; IONIA COUNTY
 (EXCEPT THE CITY OF
 PORTLAND); IOSCO,
 ISABELLA, KALAMAZOO,
 KALKASKA, KENT,
 LAKE, LEELANAU, MANISTEE,
 MASON, MECOSTA, MIDLAND,
 MISSAUKEE, MONTCALM,
 MONTMORENCY, MUSKEGON,
 NEWAYGO, OCEANA, OGEMAW,
 OSCEOLA, OSCODA, OTSEGO,
 OTTAWA, PRESQUE ISLE,

ROSCOMMON, SAGINAW, ST.
 JOSEPH, TUSCOLA, VAN BUREN
 AND WEXFORD COUNTIES:

GROUP 1.....	\$ 22.42	16.72
GROUP 2.....	\$ 22.15	16.72
GROUP 3.....	\$ 22.26	16.72
GROUP 4.....	\$ 22.33	16.72
GROUP 5.....	\$ 22.45	16.72
GROUP 6.....	\$ 19.67	16.72
GROUP 7.....	\$ 22.30	16.72

ZONE 5 - ALGER, BARAGA,
 CHIPPEWA, DELTA,
 DICKINSON, GOGEBIC,
 HOUGHTON, IRON,
 KEWEENAW, LUCE, MACKINAC,
 MARQUETTE, MENOMINEE,
 ONTONAGON AND SCHOOLCRAFT
 COUNTIES:

GROUP 1.....	\$ 22.24	16.72
GROUP 2.....	\$ 22.38	16.72
GROUP 3.....	\$ 22.51	16.72
GROUP 4.....	\$ 22.56	16.72
GROUP 5.....	\$ 22.64	16.72
GROUP 6.....	\$ 19.99	16.72
GROUP 7.....	\$ 22.45	16.72

SCOPE OF WORK:

Open cut construction work shall be construed to mean work which requires the excavation of earth including industrial, commercial and residential building site excavation and preparation, land balancing, demolition and removal of concrete and underground appurtenances, grading, paving, sewers, utilities and improvements; retention, oxidation, flocculation and irrigation facilities, and also including but not limited to underground piping, conduits, steel sheeting for underground construction, and all work incidental thereto, and general excavation. For all areas except the Upper Peninsula, open cut construction work shall also be construed to mean waterfront work, piers, docks, seawalls, breakwalls, marinas and all incidental work. Open cut construction work shall not include any structural modifications, alterations, additions and repairs to buildings, or highway work, including roads, streets, bridge construction and parking lots or steel erection work and excavation for the building itself and back filling inside of and within 5 ft. of the building and foundations, footings and piers for the building. Open cut construction work shall not include any work covered under Tunnel, Shaft and Caisson work.

OPEN CUT LABORER CLASSIFICATIONS

GROUP 1: Construction laborer

GROUP 2: Mortar and material mixer, concrete form person, signal person, well point person, manhole, headwall and catch basin builder, headwall, seawall, breakwall and dock builder

GROUP 3: Air, gasoline and electric tool operator, vibrator operator, driller, pump person, tar kettle operator, bracer, rodder, reinforced steel or mesh person (e.g., wire mesh, steel mats, dowel bars, etc.), welder, pipe jacking and boring person, wagon drill and air track operator and

concrete saw operator (under 40 h.p.), windlass and tugger person and directional boring person

GROUP 4: Trench or excavating grade person

GROUP 5: Pipe layer (including crock, metal pipe, multi-plate or other conduits)

GROUP 6: Grouting man, audio-visual television operations and all other operations in connection with closed circuit television inspection, pipe cleaning and pipe relining work and the installation and repair of water service pipe and appurtenances

GROUP 7: Restoration laborer, seeding, sodding, planting, cutting, mulching and top soil grading; and the restoration of property such as replacing mailboxes, wood chips, planter boxes, flagstones, etc.

LAB00465-001 06/01/2022

LABORER: Highway, Bridge and Airport Construction

AREA 1: GENESEE, MACOMB, MONROE, OAKLAND, WASHTENAW AND WAYNE COUNTIES

AREA 2: ALLEGAN, BARRY, BAY, BERRIEN, BRANCH, CALHOUN, CASS, CLINTON, EATON, GRATIOT, HILLSDALE, HURON, INGHAM, JACKSON, KALAMAZOO, LAPEER, LENAWEE, LIVINGSTON, MIDLAND, MUSKEGON, SAGINAW, SANILAC, SHIAWASSEE, ST. CLAIR, ST. JOSEPH, TUSCOLA AND VAN BUREN COUNTIES

AREA 3: ALCONA, ALPENA, ANTRIM, ARENAC, BENZIE, CHARLEVOIX, CHEBOYGAN, CLARE, CRAWFORD, EMMET, GLADWIN, GRAND TRAVERSE, IONIA, IOSCO, ISABELLA, KALKASKA, KENT, LAKE, LEELANAU, MANISTEE, MASON, MECOSTA, MISSAUKEE, MONTCALM, MONTMORENCY, NEWAYGO, OCEANA, OGEMAW, OSCEOLA, OSCODA, OTSEGO, OTTAWA, PRESQUE ISLE, ROSCOMMON AND WEXFORD COUNTIES

AREA 4: ALGER, BARAGA, CHIPPEWA, DELTA, DICKINSON, GOGEBIC, HOUGHTON, IRON, KEWEENAW, LUCE, MACKINAC, MARQUETTE, MENOMINEE, ONTONAGON AND SCHOOLCRAFT COUNTIES

	Rates	Fringes
LABORER (AREA 1)		
GROUP 1.....	\$ 32.02	13.95
GROUP 2.....	\$ 32.15	13.95
GROUP 3.....	\$ 32.33	13.95
GROUP 4.....	\$ 32.41	13.95
GROUP 5.....	\$ 32.62	13.95
GROUP 6.....	\$ 32.92	13.95
LABORER (AREA 2)		
GROUP 1.....	\$ 26.92	12.90
GROUP 2.....	\$ 27.12	12.90
GROUP 3.....	\$ 27.36	12.90
GROUP 4.....	\$ 27.71	12.90
GROUP 5.....	\$ 27.58	12.90
GROUP 6.....	\$ 27.92	12.90
LABORER (AREA 3)		
GROUP 1.....	\$ 26.22	12.90
GROUP 2.....	\$ 26.43	12.90
GROUP 3.....	\$ 26.72	12.90

GROUP 4.....	\$ 27.16	12.90
GROUP 5.....	\$ 26.78	12.90
GROUP 6.....	\$ 27.21	12.90
LABORER (AREA 4)		
GROUP 1.....	\$ 26.22	12.90
GROUP 2.....	\$ 26.43	12.90
GROUP 3.....	\$ 26.72	12.90
GROUP 4.....	\$ 27.16	12.90
GROUP 5.....	\$ 26.78	12.90
GROUP 6.....	\$ 27.21	12.90

LABORER CLASSIFICATIONS

GROUP 1: Asphalt shoveler or loader; asphalt plant misc.; burlap person; yard person; dumper (wagon, truck, etc.); joint filling laborer; miscellaneous laborer; unskilled laborer; sprinkler laborer; form setting laborer; form stripper; pavement reinforcing; handling and placing (e.g., wire mesh, steel mats, dowel bars); mason's tender or bricklayer's tender on manholes; manhole builder; headwalls, etc.; waterproofing, (other than buildings) seal coating and slurry mix, shoring, underpinning; pressure grouting; bridge pin and hanger removal; material recycling laborer; horizontal paver laborer (brick, concrete, clay, stone and asphalt); ground stabilization and modification laborer; grouting; waterblasting; top person; railroad track and trestle laborer; carpenters' tender; guard rail builders' tender; earth retention barrier and wall and M.S.E. wall installer's tender; highway and median installer's tender (including sound, retaining, and crash barriers); fence erector's tender; asphalt raker tender; sign installer; remote control operated equipment.

GROUP 2: Mixer operator (less than 5 sacks); air or electric tool operator (jackhammer, etc.); spreader; boxperson (asphalt, stone, gravel); concrete paddler; power chain saw operator; paving batch truck dumper; tunnel mucker (highway work only); concrete saw (under 40 h.p.) and dry pack machine; roto-mill grounds person.

GROUP 3: Tunnel miner (highway work only); finishers tenders; guard rail builders; highway and median barrier installer; earth retention barrier and wall and M.S.E. wall installer's (including sound, retaining and crash barriers); fence erector; bottom person; powder person; wagon drill and air track operator; diamond and core drills; grade checker; certified welders; curb and side rail setter's tender.

GROUP 4: Asphalt raker

GROUP 5: Pipe layers, oxy-gun

GROUP 6: Line-form setter for curb or pavement; asphalt screed checker/screw man on asphalt paving machines.

LABO1076-005 04/01/2023

MICHIGAN STATEWIDE

	Rates	Fringes
LABORER (DISTRIBUTION WORK)		
Zone 1.....	\$ 25.17	13.32

Zone 2.....	\$ 24.22	13.45
Zone 3.....	\$ 21.60	13.45
Zone 4.....	\$ 20.97	13.43
Zone 5.....	\$ 21.00	13.40

DISTRIBUTION WORK - The construction, installation, treating and reconditioning of distribution pipelines transporting coal, oil, gas or other similar materials, vapors or liquids, including pipelines within private property boundaries, up to and including the meter settings on residential, commercial, industrial, institutional, private and public structures. All work covering pumping stations and tank farms not covered by the Building Trades Agreement. Other distribution lines with the exception of sewer, water and cable television are included.

Underground Duct Layer Pay: \$.40 per hour above the base pay rate.

Zone 1 - Macomb, Oakland and Wayne

Zone 2 - Monroe and Washtenaw

Zone 3 - Bay, Genesee, Lapeer, Midland, Saginaw, Sanilac, Shiawassee and St. Clair

Zone 4 - Alger, Baraga, Chippewa, Delta, Dickinson, Gogebic, Houghton, Iron, Keweenaw, Luce, Mackinac, Marquette, Menominee, Ontonagon and Schoolcraft

Zone 5 - Remaining Counties in Michigan

PAIN0022-002 07/01/2008

HILLSDALE, JACKSON AND LENAWEE COUNTIES; LIVINGSTON COUNTY (east of the eastern city limits of Howell, not including the city of Howell, north to the Genesee County line and south to the Washtenaw County line); MACOMB, MONROE, OAKLAND, WASHTENAW AND WAYNE COUNTIES:

	Rates	Fringes
PAINTER.....	\$ 25.06	14.75

FOOTNOTES: For all spray work and journeyman rigging for spray work, also blowing off, \$0.80 per hour additional (applies only to workers doing rigging for spray work on off the floor work. Does not include setting up or moving rigging on floor surfaces, nor does it apply to workers engaged in covering up or tending spray equipment. For all sandblasting and spray work performed on highway bridges, overpasses, tanks or steel, \$0.80 per hour additional. For all brushing, cleaning and other preparatory work (other than spraying or steeplejack work) at scaffold heights of fifty (50) feet from the ground or higher, \$0.50 per hour additional. For all preparatorial work and painting performed on open steel under forty (40) feet when no scaffolding is involved, \$0.50 per hour additional. For all swing stage work-window jacks and window belts-exterior and interior, \$0.50 per hour additional. For all spray work and sandblaster work to a scaffold height of forty (40) feet above the floor level, \$0.80 per hour additional. For all preparatorial work and painting on all highway bridges or overpasses up to forty (40) feet in height, \$0.50 per hour additional. For all steeplejack work performed where the elevation is forty (40) feet or more, \$1.25 per hour additional.

 PAIN0312-001 06/01/2018

EXCLUDES: ALLEGAN COUNTY (Townships of Dorr, Fillmore, Heath, Hopkins, Laketown, Leighton, Manlius, Monterey, Overisel, Salem, Saugatuck and Wayland); INCLUDES: Barry, Berrien, Branch, Calhoun, Cass, Hillsdale, Kalamazoo, St. Joseph, Van Buren

	Rates	Fringes
PAINTER		
Brush and roller.....	\$ 23.74	13.35
Spray, Sandblast, Sign		
Painting.....	\$ 24.94	13.35

 PAIN0845-003 05/10/2018

CLINTON COUNTY; EATON COUNTY (does not include the townships of Bellevue and Olivet); INGHAM COUNTY; IONIA COUNTY (east of Hwy. M 66); LIVINGSTON COUNTY (west of the eastern city limits of Howell, including the city of Howell, north to the Genesee County line and south to the Washtenaw County line); AND SHIAWASSEE COUNTY (Townships of Bennington, Laingsbury and Perry):

	Rates	Fringes
PAINTER.....	\$ 25.49	13.74

 PAIN0845-015 05/10/2018

MUSKEGON COUNTY; NEWAYGO COUNTY (except the Townships of Barton, Big Prairie, Brooks, Croton, Ensley, Everett, Goodwell, Grant, Home, Monroe, Norwich and Wilcox); OCEANA COUNTY; OTTAWA COUNTY (except the townships of Allendale, Blendone, Chester, Georgetown, Holland, Jamestown, Olive, Park, Polkton, Port Sheldon, Tallmadge, Wright and Zeeland):

	Rates	Fringes
PAINTER.....	\$ 25.49	13.74

 PAIN0845-018 05/10/2018

ALLEGAN COUNTY (Townships of Dorr, Fillmore, Heath, Hopkins, Laketown, Leighton, Manlius, Monterey, Overisel, Salem, Saugatuck and Wayland); IONIA COUNTY (west of Hwy. M-66); KENT, MECOSTA AND MONTCALM COUNTIES; NEWAYGO COUNTY (Townships of Barton, Big Prairie, Brooks, Croton, Ensley, Everett, Goodwell, Grant, Home, Monroe, Norwich and Wilcox); OSCEOLA COUNTY (south of Hwy. #10); OTTAWA COUNTY (Townships of Allendale, Blendone, Chester, Georgetown, Holland, Jamestown, Olive, Park, Polkton, Port Sheldon, Tallmadge, Wright and Zeeland):

	Rates	Fringes
PAINTER.....	\$ 25.49	13.74

FOOTNOTES: Lead abatement work: \$1.00 per hour additional.

 PAIN1011-003 06/02/2022

ALGER, BARAGA, CHIPPEWA, DELTA, DICKINSON, GOGEBIC, HOUGHTON,
 IRON, KEWEENAW, LUCE, MACKINAC, MARQUETTE, MENOMINEE, ONTONAGON
 AND SCHOOLCRAFT COUNTIES:

	Rates	Fringes
PAINTER.....	\$ 24.66	14.99

FOOTNOTES: High pay (bridges, overpasses, watertower): 30 to
 80 ft.: \$.65 per hour additional. 80 ft. and over: \$1.30
 per hour additional.

 PAIN1474-002 06/01/2010

HURON COUNTY; LAPEER COUNTY (east of Hwy. M-53); ST. CLAIR,
 SANILAC AND TUSCOLA COUNTIES:

	Rates	Fringes
PAINTER.....	\$ 23.79	12.02

FOOTNOTES: Lead abatement work: \$1.00 per hour additional.
 Work with any hazardous material: \$1.00 per hour
 additional. Sandblasting, steam cleaning and acid cleaning:
 \$1.00 per hour additional. Ladder work at or above 40 ft.,
 scaffold work at or above 40 ft., swing stage, boatswain
 chair, window jacks and all work performed over a falling
 height of 40 ft.: \$1.00 per hour additional. Spray gun
 work, pick pullers and those handling needles, blowing off
 by air pressure, and any person rigging (setting up and
 moving off the ground): \$1.00 per hour additional.
 Steeplejack, tanks, gas holders, stacks, flag poles, radio
 towers and beacons, power line towers, bridges, etc.: \$1.00
 per hour additional, paid from the ground up.

 PAIN1803-003 06/01/2019

ALCONA, ALPENA, ANTRIM, ARENAC, BAY, BENZIE, CHARLEVOIX,
 CHEBOYGAN, CLARE, CRAWFORD, EMMET, GLADWIN, GRAND TRAVERSE,
 GRATIOT, IOSCO, ISABELLA, KALKASKA, LAKE, LEELANAU, MANISTEE,
 MASON, MIDLAND, MISSAUKEE, MONTMORENCY AND OGEMAW COUNTIES;
 OSCEOLA COUNTY (north of Hwy. #10); OSCODA, OTSEGO, PRESQUE
 ISLE, ROSCOMMON, SAGINAW AND WEXFORD COUNTIES:

	Rates	Fringes
PAINTER Work performed on water, bridges over water or moving traffic, radio and powerline towers, elevated tanks, steeples, smoke stacks over 40 ft. of falling heights, recovery of lead-based paints and any work associated with industrial plants, except		

maintenance of industrial plants.....	\$ 25.39	14.68
All other work, including maintenance of industrial plant.....	\$ 25.39	14.68

FOOTNOTES: Spray painting, sandblasting, blowdown associated with spraying and blasting, water blasting and work involving a swing stage, boatswain chair or spider: \$1.00 per hour additional. All work performed inside tanks, vessels, tank trailers, railroad cars, sewers, smoke stacks, boilers or other spaces having limited egress not including buildings, opentop tanks, pits, etc.: \$1.25 per hour additional.

 PLAS0514-001 06/01/2018

ZONE 1: GENESEE, LIVINGSTON, MACOMB, MONROE, OAKLAND, SAGINAW, WASHTENAW AND WAYNE COUNTIES

ZONE 2: ALCONA, ALGER, ALLEGAN, ALPENA, ANTRIM, ARENAC, BARAGA, BARRY, BAY, BENZIE, BERRIEN, BRANCH, CALHOUN, CASS, CHARLEVOIX, CHEBOYGAN, CHIPPEWA, CLARE, CLINTON, CRAWFORD, DELTA, DICKINSON, EATON, EMMET, GLADWIN, GOGEBIC, GRAND TRAVERSE, GRATIOT, HILLSDALE, HOUGHTON, HURON, INGHAM, IONIA, IOSCO, IRON, ISABELLA, JACKSON, KALAMAZOO, KALKASKA, KENT, KEWEENAW, LAKE, LAPEER, LEELANAU, LENAWEE, LUCE, MACKINAC, MANISTEE, MARQUETTE, MASON, MECOSTA, MENOMINEE, MIDLAND, MISSAUKEE, MONTCALM, MONTMORENCY, MUSKEGON, NEWAYGO, OCEANA, OGEMAW, ONTONAGON, OSCEOLA, OSCODA, OTSEGO, OTTAWA, PRESQUE ISLE, ROSCOMMON, SANILAC, SCHOOLCRAFT, SHIAWASSEE, ST. CLAIR, ST. JOSEPH, TUSCOLA, VAN BUREN AND WEXFORD COUNTIES

	Rates	Fringes
CEMENT MASON/CONCRETE FINISHER		
ZONE 1.....	\$ 31.47	13.81
ZONE 2.....	\$ 29.97	13.81

 PLUM0190-003 05/01/2015

ALCONA, ALGER, ALLEGAN, ALPENA, ANTRIM, ARENAC, BARAGA, BARRY, BAY, BENZIE, BERRIEN, BRANCH, CALHOUN, CASS, CHARLEVOIX, CHEBOYGAN, CHIPPEWA, CLARE, CLINTON, CRAWFORD, DELTA, DICKINSON, EATON, EMMET, GENESEE, GLADWIN, GOGEBIC, GRAND TRAVERSE, GRATIOT, HILLSDALE, HOUGHTON, HURON, INGHAM, IONIA, IOSCO, IRON, ISABELLA, JACKSON, KALAMAZOO, KALKASKA, KENT, KEWEENAW, LAKE, LAPEER, LEELANAU, LENAWEE, LIVINGSTON, LUCE, MACKINAC, MACOMB, MANISTEE, MARQUETTE, MASON, MECOSTA, MENOMINEE, MIDLAND, MISSAUKEE, MONTCALM, MONTMORENCY, MONROE, MUSKEGON, NEWAYGO, OAKLAND, OCEANA, OGEMAW, ONTONAGON, OSCEOLA, OSCODA, OTSEGO, OTTAWA, PRESQUE ISLE, ROSCOMMON, SAGINAW, ST. CLARE, ST. JOSEPH, SANILAC, SCHOOLCRAFT, SHIAWASSEE, TUSCOLA, VAN BUREN, WASHTENAW, WAYNE AND WEXFORD COUNTIES

	Rates	Fringes
Plumber/Pipefitter - gas distribution pipeline: Welding in conjunction with gas distribution pipeline work.....	\$ 33.03	20.19

All other work:.....\$ 24.19 12.28

TEAM0007-004 06/01/2020

AREA 1: ALCONA, ALGER, ALLEGAN, ALPENA, ANTRIM, ARENAC, BARAGA, BARRY, BAY, BENZIE, BERRIEN, BRANCH, CALHOUN, CASS, CHARLEVOIX, CHEBOYGAN, CHIPPEWA, CLARE, CLINTON, CRAWFORD, DELTA, DICKINSON, EATON, EMMET, GLADWIN, GOGEBIC, GRAND TRAVERSE, GRATIOT, HILLSDALE, HOUGHTON, HURON, INGHAM, IONIA, IOSCO, IRON, ISABELLA, JACKSON, KALAMAZOO, KALKASKA, KENT, KEWEENAW, LAKE, LAPEER, LEELANAU, LENAWEE, LUCE, MACKINAC, MANISTEE, MARQUETTE, MASON, MECOSTA, MENOMINEE, MIDLAND, MISSAUKEE, MONTCALM, MONTMORENCY, MUSKEGON, NEWAYGO, OCEANA, OGEMAW, ONTONAGON, OSCEOLA, OSCODA, OTSEGO, OTTAWA, PRESQUE ISLE, ROSCOMMON, SAGINAW, SANILAC, SCHOOLCRAFT, SHIAWASSEE, ST. CLAIR, ST. JOSEPH, TUSCOLA, VAN BUREN AND WEXFORD COUNTIES

AREA 2: GENESEE, LIVINGSTON, MACOMB, MONROE, OAKLAND, WASHTENAW AND WAYNE COUNTIES

Rates Fringes

TRUCK DRIVER

AREA 1

Euclids, double bottoms and lowboys.....\$ 28.05 .50 + a+b
Trucks under 8 cu. yds.....\$ 27.80 .50 + a+b
Trucks, 8 cu. yds. and over.....\$ 27.90 .50 + a+b

AREA 2

Euclids, double bottomms and lowboys.....\$ 24.895 .50 + a+b
Euclids, double bottoms and lowboys.....\$ 28.15 .50 + a+b
Trucks under 8 cu. yds.....\$ 27.90 .50 + a+b
Trucks, 8 cu. yds. and over.....\$ 28.00 .50 + a+b

Footnote:

- a. \$470.70 per week
- b. \$68.70 daily

TEAM0247-004 04/01/2013

AREA 1: ALCONA, ALGER, ALLEGAN, ALPENA, ANTRIM, ARENAC, BARAGA, BARRY, BAY, BENZIE, BERRIEN, BRANCH, CALHOUN, CASS, CHARLEVOIX, CHEBOYGAN, CHIPPEWA, CLARE, CLINTON, CRAWFORD, DELTA, DICKINSON, EATON, EMMET, GLADWIN, GOGEBIC, GRAND TRAVERSE, GRATIOT, HILLSDALE, HOUGHTON, HURON, INGHAM, IONIA, IOSCO, IRON, ISABELLA, JACKSON, KALAMAZOO, KALKASKA, KENT, KEWEENAW, LAKE, LAPEER, LEELANAU, LENAWEE, LUCE, MACKINAC, MANISTEE, MARQUETTE, MASON, MECOSTA, MENOMINEE, MIDLAND, MISSAUKEE, MONTCALM, MONTMORENCY, MUSKEGON, NEWAYGO, OCEANA, OGEMAW, ONTONAGON, OSCEOLA, OSCODA, OTSEGO, OTTAWA, PRESQUE ISLE, ROSCOMMON, SANILAC, SCHOOLCRAFT, SHIAWASSEE, SAGINAW, ST. CLAIR, ST. JOSEPH, TUSCOLA, VAN BUREN AND WEXFORD COUNTIES

AREA 2: GENESEE, LIVINGSTON, MACOMB, MONROE, OAKLAND, WASHTENAW AND WAYNE COUNTIES

Rates Fringes

Sign Installer

AREA 1		
GROUP 1.....	\$ 21.78	11.83
GROUP 2.....	\$ 25.27	11.8375
AREA 2		
GROUP 1.....	\$ 22.03	11.83
GROUP 2.....	\$ 25.02	11.8375

FOOTNOTE:

a. \$132.70 per week, plus \$17.80 per day.

SIGN INSTALLER CLASSIFICATIONS:

GROUP 1: performs all necessary labor and uses all tools required to construct and set concrete forms required in the installation of highway and street signs

GROUP 2: performs all miscellaneous labor, uses all hand and power tools, and operates all other equipment, mobile or otherwise, required for the installation of highway and street signs

TEAM0247-010 04/01/2018

AREA 1: LAPEER AND SHIAWASSEE COUNTIES

AREA 2: GENESEE, MACOMB, MONROE, OAKLAND, ST. CLAIR, WASHTENAW AND WAYNE COUNTIES

Rates Fringes

TRUCK DRIVER (Underground construction)

AREA 1		
GROUP 1.....	\$ 23.82	19.04
GROUP 2.....	\$ 23.91	19.04
GROUP 3.....	\$ 24.12	19.04
AREA 2		
GROUP 1.....	\$ 24.12	19.04
GROUP 2.....	\$ 24.26	19.04
GROUP 3.....	\$ 24.45	19.04

PAID HOLIDAYS: New Year's Day, Memorial Day, Fourth of July, Labor Day, Thanksgiving Day and Christmas Day.

SCOPE OF WORK: Excavation, site preparation, land balancing, grading, sewers, utilities and improvements; also including but not limited to, tunnels, underground piping, retention, oxidation, flocculation facilities, conduits, general excavation and steel sheeting for underground construction. Underground construction work shall not include any structural modifications, alterations, additions and repairs to buildings or highway work, including roads, streets, bridge construction and parking lots or steel erection.

TRUCK DRIVER CLASSIFICATIONS

GROUP 1: Truck driver on all trucks (EXCEPT dump trucks of 8 cubic yards capacity or over, pole trailers, semis, low boys, Euclid, double bottom and fuel trucks)

GROUP 2: Truck driver on dump trucks of 8 cubic yards capacity or over, pole trailers, semis and fuel trucks

GROUP 3: Truck driver on low boy, Euclid and double bottom

 * SUMI2002-001 05/01/2002

	Rates	Fringes
Flag Person.....	\$ 10.10 **	0.00
LINE PROTECTOR (ZONE 1: GENESEE, MACOMB, MONROE, OAKLAND, WASHTENAW AND WAYNE)....	\$ 22.89	13.45
LINE PROTECTOR (ZONE 2: STATEWIDE (EXCLUDING GENESEE, MACOMB, MONROE, OAKLAND, WASHTENAW AND WAYNE).....	\$ 20.19	13.45
Pavement Marking Machine (ZONE 1: GENESEE, MACOMB, MONROE, OAKLAND, WASHTENAW AND WAYNE COUNTIES) Group 1.....	\$ 30.52	13.45
Pavement Marking Machine (ZONE 1: GENESEE, MACOMB, MONROE, OAKLAND, WASHTENAW AND WAYNE) Group 2.....	\$ 27.47	13.45
Pavement Marking Machine (ZONE 2: STATEWIDE (EXCLUDING GENESEE, MACOMB, MONROE, OAKLAND, WASHTENAW AND WAYNE COUNTIES) Group 1.....	\$ 26.92	13.45
Pavement Marking Machine (ZONE 2: STATEWIDE (EXCLUDING GENESEE, MACOMB, MONROE, OAKLAND, WASHTENAW AND WAYNE) Group 2.....	\$ 24.23	13.45

WORK CLASSIFICATIONS:

PAVEMENT MARKER GROUP 1: Drives or operates a truck mounted striper, grinder, blaster, groover, or thermoplastic melter for the placement or removal of temporary or permanent pavement markings or markers.

PAVEMENT MARKER GROUP 2: Performs all functions involved for the placement or removal of temporary or permanent pavement markings or markers not covered by the classification of Pavement Marker Group 1 or Line Protector.

LINE PROTECTOR: Performs all operations for the protection or removal of temporary or permanent pavement markings or markers in a moving convoy operation not performed by the classification of Pavement Marker Group 1. A moving convoy operation is comprised of only Pavement Markers Group 1 and Line Protectors.

WELDERS - Receive rate prescribed for craft performing operation to which welding is incidental.

=====
** Workers in this classification may be entitled to a higher minimum wage under Executive Order 14026 (\$16.20) or 13658 (\$12.15). Please see the Note at the top of the wage determination for more information.

Note: Executive Order (EO) 13706, Establishing Paid Sick Leave for Federal Contractors applies to all contracts subject to the Davis-Bacon Act for which the contract is awarded (and any solicitation was issued) on or after January 1, 2017. If this contract is covered by the EO, the contractor must provide employees with 1 hour of paid sick leave for every 30 hours they work, up to 56 hours of paid sick leave each year. Employees must be permitted to use paid sick leave for their own illness, injury or other health-related needs, including preventive care; to assist a family member (or person who is like family to the employee) who is ill, injured, or has other health-related needs, including preventive care; or for reasons resulting from, or to assist a family member (or person who is like family to the employee) who is a victim of, domestic violence, sexual assault, or stalking. Additional information on contractor requirements and worker protections under the EO is available at <https://www.dol.gov/agencies/whd/government-contracts>.

Unlisted classifications needed for work not included within the scope of the classifications listed may be added after award only as provided in the labor standards contract clauses (29CFR 5.5 (a) (1) (ii)).

The body of each wage determination lists the classification and wage rates that have been found to be prevailing for the cited type(s) of construction in the area covered by the wage determination. The classifications are listed in alphabetical order of ""identifiers"" that indicate whether the particular rate is a union rate (current union negotiated rate for local), a survey rate (weighted average rate) or a union average rate (weighted union average rate).

Union Rate Identifiers

A four letter classification abbreviation identifier enclosed in dotted lines beginning with characters other than ""SU"" or ""UAVG"" denotes that the union classification and rate were prevailing for that classification in the survey. Example: PLUM0198-005 07/01/2014. PLUM is an abbreviation identifier of the union which prevailed in the survey for this classification, which in this example would be Plumbers. 0198 indicates the local union number or district council number where applicable, i.e., Plumbers Local 0198. The next number, 005 in the example, is an internal number used in processing the wage determination. 07/01/2014 is the effective date of the most current negotiated rate, which in this example is July 1, 2014.

Union prevailing wage rates are updated to reflect all rate changes in the collective bargaining agreement (CBA) governing this classification and rate.

Survey Rate Identifiers

Classifications listed under the ""SU"" identifier indicate that no one rate prevailed for this classification in the survey and the published rate is derived by computing a weighted average rate based on all the rates reported in the survey for that classification. As this weighted average rate includes all rates reported in the survey, it may include both union and non-union rates. Example: SULA2012-007 5/13/2014. SU indicates the rates are survey rates based on a weighted average calculation of rates and are not majority rates. LA indicates the State of Louisiana. 2012 is the year of survey on which these classifications and rates are based. The next number, 007 in the example, is an internal number used in producing the wage determination. 5/13/2014 indicates the survey completion date for the classifications and rates under that identifier.

Survey wage rates are not updated and remain in effect until a new survey is conducted.

Union Average Rate Identifiers

Classification(s) listed under the UAVG identifier indicate that no single majority rate prevailed for those classifications; however, 100% of the data reported for the classifications was union data. EXAMPLE: UAVG-OH-0010 08/29/2014. UAVG indicates that the rate is a weighted union average rate. OH indicates the state. The next number, 0010 in the example, is an internal number used in producing the wage determination. 08/29/2014 indicates the survey completion date for the classifications and rates under that identifier.

A UAVG rate will be updated once a year, usually in January of each year, to reflect a weighted average of the current negotiated/CBA rate of the union locals from which the rate is based.

WAGE DETERMINATION APPEALS PROCESS

1.) Has there been an initial decision in the matter? This can be:

- * an existing published wage determination
- * a survey underlying a wage determination
- * a Wage and Hour Division letter setting forth a position on a wage determination matter
- * a conformance (additional classification and rate) ruling

On survey related matters, initial contact, including requests for summaries of surveys, should be with the Wage and Hour National Office because National Office has responsibility for the Davis-Bacon survey program. If the response from this initial contact is not satisfactory, then the process described in 2.) and 3.) should be followed.

With regard to any other matter not yet ripe for the formal process described here, initial contact should be with the

Branch of Construction Wage Determinations. Write to:

Branch of Construction Wage Determinations
Wage and Hour Division
U.S. Department of Labor
200 Constitution Avenue, N.W.
Washington, DC 20210

2.) If the answer to the question in 1.) is yes, then an interested party (those affected by the action) can request review and reconsideration from the Wage and Hour Administrator (See 29 CFR Part 1.8 and 29 CFR Part 7). Write to:

Wage and Hour Administrator
U.S. Department of Labor
200 Constitution Avenue, N.W.
Washington, DC 20210

The request should be accompanied by a full statement of the interested party's position and by any information (wage payment data, project description, area practice material, etc.) that the requestor considers relevant to the issue.

3.) If the decision of the Administrator is not favorable, an interested party may appeal directly to the Administrative Review Board (formerly the Wage Appeals Board). Write to:

Administrative Review Board
U.S. Department of Labor
200 Constitution Avenue, N.W.
Washington, DC 20210

4.) All decisions by the Administrative Review Board are final.

=====

END OF GENERAL DECISIO"

APPENDIX C



SPECIFICATIONS

**Patch Address List
Standard RCKC Road Repair
RCKC Construction Guidelines**

**2023 WATER MAIN BREAK ROAD PATCH
REPLACEMENT**

Bid Reference #: 91395-007.0

Patch Address List

205 N Berkley
1828 Common Wealth Ave
3714 Lake St
7301 12th St (shoulder)
310 E Thomas
600 Service Ln
220 W Thomas St
2207 Lake St
5350 PLATEAU
5135 PORTAGE RD
3410 ENTERPRISE
1221 E MOSEL
4104 NAZARETH
2424 NICHOLS
2810 N BURDICK
1726 MT OLIVET
1414 CHEROKEE
1358 CLIMAX
3546 GRAND PRAIRIE
136 N LAUDERDALE
3506 MARLANE AVE
426 SOLON
308 SOLON
1208 WARREN
617 N DARTMOUTH
8560 WESTERN WOODS
1815 HENSON
503 IRA
2519 E MAIN
1325 WAYSIDE
233 CHICAGO
708 CHICAGO
1324 CRAFT AVE
1012 GAYLE AVE
233 Chicago (2nd area)
616 N Dartmouth
5135 Portage (2nd area)
932 Warren
1104 Warren
1110 Warren
1112 Warren
1114 Warren
1118 Warren
1128 Warren
1204 Warren
1207 Warren
1223 Warren

STANDARD RCKC ROAD REPAIR

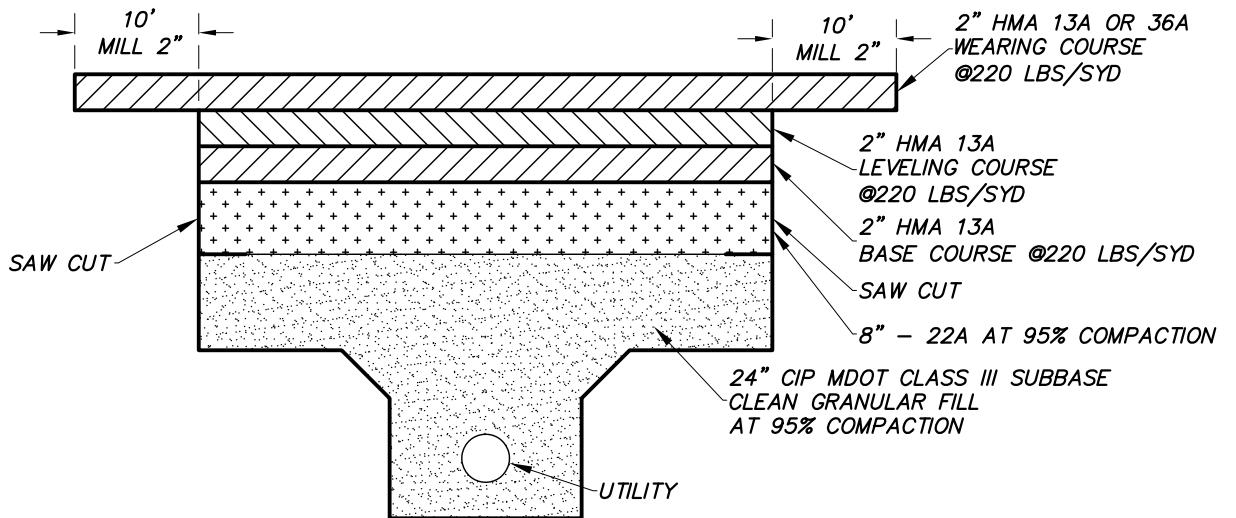

NOTE:

- FOR USE BETWEEN APRIL 15 & NOVEMBER 15.
- WORK SHALL BE DONE IN ACCORDANCE WITH THE RCKC CONSTRUCTION GUIDELINES.
- HMA ROAD SURFACE REPAIRS SHALL BE EQUAL TO OR BETTER THAN THE EXISTING ROAD.
- PAYMENT SHALL BE BASED ON SAW CUT LIMITS.



CITY OF KALAMAZOO
Department Of Public Services

STANDARD RCKC ROAD REPAIR

05/10/2023

DATE

RECOMMENDED BY _____

APPROVED BY _____

APPROVED BY _____

ACCEPTED BY _____

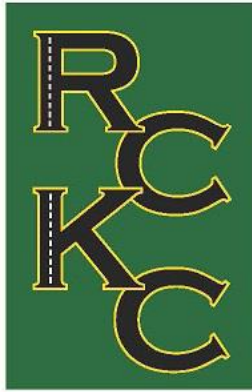

Road Commission of Kalamazoo County

3801 E. Kilgore Road • Kalamazoo, Michigan 49001
Phone: (269) 381-3171 • Fax: (269) 381-1760
www.kalamazooountyroads.com

Construction Guidelines

Effective
January 1, 2017

CONSTRUCTION GUIDELINES

WHEREAS, the Board of County Road Commissioners of the County of Kalamazoo, Michigan, deems it necessary to adopt construction guidelines relative to the construction of highways and appurtenant structures coming under our jurisdiction; and

WHEREAS, such procedures, guidelines, and specifications function to provide rules, regulations, and assistance to RCKC land developers and others to ensure that public highways, dedicated for public use, are constructed with approved materials and by appropriate methods,

NOW, THEREFORE, BE IT RESOLVED, that the CONSTRUCTION GUIDELINES , as filed with us on this date, by and the same, are hereby adopted as administrative rules and regulations governing the development of public roads and the same shall be known and cited as our CONSTRUCTION GUIDELINES ,

BE IT FURTHER RESOLVED, that in the event other previous resolutions or parts of previous resolutions conflict with this resolution adopting the aforesaid CONSTRUCTION GUIDELINES, such resolutions, or parts thereof, only to the extent of conflict, are hereby repealed.

BE IT FURTHER RESOLVED, that if any section, clause, or portion of the aforesaid CONSTRUCTION GUIDELINES be declared invalid by the courts, the balance of same shall remain valid and in effect, except for the part declared invalid.

BE IT FURTHER RESOLVED that the effective date of the aforesaid CONSTRUCTION GUIDELINES shall be January 1, 2017.

BOARD OF COUNTY ROAD COMMISSIONERS
OF THE COUNTY OF KALAMAZOO

By: _____

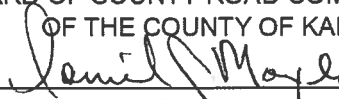
Daniel J. Moyle, Chairman

VI. CROSSROAD CUTS, TRENCHES, REMOVAL OF PAVEMENT AND RESTORATION

Construction of all utilities and other facilities for existing highways, roads, and streets shall conform to the requirements and specifications provided below.

The RCKC Application to [Construct, Operate, Use and/or Maintain Remove Within the Right-of-Way or to Close A County Roadway](#) shall be submitted for approval prior to issuance of the permit. Permittee agrees to conform with all of the requirements of the [Public Act 174 of 2013](#) known as the MISS DIG Underground Facility Damage Prevention and Safety Act.

A. Location

1. Public Roads

The following location requirements for longitudinal occupancy of utilities shall be adhered to unless another location is specifically approved by the RCKC.

Utilities constructed prior to the acceptance of the plans shall be shown and comply with existing RCKC requirements. If they are to be placed within the ROW, utility locations shall be staked prior to their installation and shall be placed as indicated in [Appendix D](#).

2. Limited Access Segments of North and South Sprinkle Road

Along North and South Sprinkle Road from BL I-94 to G Avenue, longitudinal occupancy of utilities shall be within 10 feet of either ROW or no closer than 10 feet to the edge of pavement. RCKC will allow only continuous type facilities that do not intermittently extend service outside the limited access ROW. The location requirements indicated in [Appendix D](#) shall be adhered to unless another location is specifically approved by the RCKC.

B. Depth

All crossroad underground facilities shall have a minimum of 5 feet of cover from top of pipe to ground level and shall have at least 2 feet of cover from top of pipe to the bottom of the ditch.

All underground facilities parallel to the road shall be maintained at a minimum of 36 inches below existing ground level, except fiber optics that will be at least 42 inches below the surface.

C. Method of Construction and Restoration

1. Construction

The method used for installation of crossroad facilities shall be described on the permit or submitted plans.

All crossroad underground facilities under HMA or concrete roads shall be

constructed by jacking and boring. Use of any other method will require specific permission on a case-by-case basis. Consideration will be given to open cut HMA roads in special cases.

Any construction carried out shall be approved, based on a permit obtained from the RCKC in advance of actual construction, and/or as soon as possible in the case of an emergency repair. Such permits will be issued with restrictions adequate to protect the interests of the motoring public and the road's physical facilities.

Except for asbestos pipe, utility owners may abandon existing underground facilities or structures that do not pose a hazard or impediment to the use and maintenance of the ROW. In any such case the utility owner shall maintain ownership and responsibility for the facility or structure. Abandonment may require that the utility owner remove its facility or structure, at the discretion of the RCKC, and restore all areas to conditions satisfactory to the RCKC. All abandoned pipe shall be pressure grout filled.

A utility owner proposing to cease operation of an asbestos pipe system shall remove the abandoned system from the ROW and shall properly dispose of the materials pursuant to applicable laws and regulations.

2. Excavation and Disposal of Excavated Material

The permittee, contractor and/or shall provide and place the necessary sheeting, shoring and bracing required to prevent caving, loss, or settling of foundation material supporting the pavement, or any other highway installation, such as sewers, culverts, etc. The permittee, contractor, and/or utility company assume full responsibility for this protection and shall not proceed in these areas before approval of methods by the RCKC's.

Excavated material shall be stocked in locations so as to not obstruct vision on the traveled portion of the highway and placed in a manner so that it interferes as little as possible with traffic flow. Sod and topsoil shall be stocked separately from other excavated material. The permittee shall dispose of all surpluses and unsuitable material outside the limits of the highway ROW unless the permit provides for disposal at approved locations within the ROW. In the latter case, the material shall be leveled and trimmed in an approved manner.

3. Backfill and Compaction Backfill

Restoration shall be such that it will provide a condition equal to or better than the original condition and comply with [MDOT Standard Specifications for Construction](#). All trenches, holes, and pits shall be filled with granular material meeting minimum requirements for MDOT Class III granular material. Material shall be placed in successive layers of not more than 12-inch depth, in loose measure, and each layer shall be thoroughly compacted as stipulated by MDOT. All backfill compaction will be subject to check by the Controlled Density Method or other approved engineering method.

4. Crossing Roadbed by Jack and Bore

When pipe is installed by jack and bore, the ends of casings shall be sealed by an approved method. The RCKC inspector shall specifically approve location of boring pits.

5. Crossing by Cutting Pavement and Trenching

When this method is approved by the RCKC, the pavement shall be cut back so that the opening is at least 24 inches wider on each side than the width of the trench. For surface restorations see [Section VI. C .6. Restoration of an HMA Road Surface](#). In all concrete surfaces or bases, edges of trench shall be formed by the use of a concrete saw. The pavement shall be removed in such a manner as to allow the reinforcing steel to protrude a sufficient distance for lapping and tying with reinforcing steel in the pavement patch. If lapping and tying cannot be accomplished, connection to patch shall be by drill and dowel method. All HMA surface or base materials shall be saw cut. Backfilling shall comply with provisions of [Section VI. C .3. Backfill and Compaction Backfill](#). After the backfill has been placed, the pavement shall be replaced with new pavement approved by the RCKC. Should work occur at a season of the year when it is not feasible to construct the new pavement, a temporary surface of HMA shall be installed and final pavement shall be placed the next May at permittee's expense.

6. Restoration of an HMA Road Surface

Repairs shall be equal to or better than the existing road. HMA surfaces shall be milled to at least 10 feet on sides of utility cut and repaved. Pavement abutting final patch shall be saw cut. Crossroad cuts are to be backfilled and compacted as described in [Section VI. C .3. Backfill and Compaction Backfill](#). Installation of material shall be to the appropriate distance from the surface to accommodate the base and pavement designated in [Section VI. C., 12., Restoring Materials](#). Unless listed otherwise, HMA shall be in lifts of no greater than 2 inches compacted in place. On roads with a HMA base, the existing base shall be replaced with an equivalent depth of new HMA. Patch surface shall be rolled to conform to the existing pavement. Restoration may require milling and machine paving of road adjacent to cut. Use of infrared equipment may be allowed. Lane width shall be consistent with the current road with a minimum width of 10 feet.

7. Restoration of a Concrete Road Surface

On a concrete road, MDOT Grade PI concrete shall be used to replace the original concrete.

8. Restoration of a Gravel Road Surface

Trenches shall be backfilled and compacted in accordance with [Section VI. C .3. Backfill and Compaction Backfill](#). to within 8 inches of the surface. In the remaining depth, 22A aggregate shall be placed and compacted to MDOT specifications.

9. Restoration of Shoulders

Shoulder restoration shall comply with [Section VI. C .3 .Backfill and Compaction Backfill](#). Specifications for shoulder restoration shall be the same as those for HMA, concrete and gravel road surfaces, [Section VI. C., 12., Restoring Materials](#). The 23A aggregate shoulder gravel shall be a minimum depth of 6 inches and shoulder width shall be consistent with the current road with minimum width of 4 feet or as determined by the RCKC. Reuse of original shoulder gravel will not be permitted.

10. Ditches and Back slopes

The permittee will be responsible for SESC measures until vegetation is well established for any cleanup deemed necessary by the RCKC . When work is necessary in the ditch line or back slope, all brush and trees in the construction area shall be completely removed. Slopes shall be regraded to existing conditions or to standard 1:4 fore slope. Rocks larger than 3 inches shall be removed. In lawn area all stone shall be removed. In accordance with [MDOT Standard Specifications for Construction](#), the construction area shall have 3 inches of topsoil in depth, dragged, rolled, seeded and mulched. All lawn area shall be replaced with sodding or 3 inches of processed topsoil and seeded to match the existing lawn. Permittees are responsible for attaining and complying with SESC regulations.

11. Gravity Sanitary Sewer Projects

For the construction of gravity sanitary sewer projects, the following requirements apply.

a. Construction:

Remove and replace entire lane to nearest edge of full-width lane remaining. Any undermined pavement shall be removed and replaced to next adjacent full width -lane or pavement edge.

The entire width of a two-lane road shall be resurfaced. On a multilane facility, unless two full-width lanes in the same direction are saved, all lanes shall be completely resurfaced. Existing pavement along curb and gutter shall be milled to accommodate any resurfacing. All paving shall conform to [MDOT Standard Specifications for Construction](#) and this policy.

b. Restoration of Shoulders:

Shoulders shall be restored in accordance with [Section VI. C .9. Restoration of Shoulders](#).

c. Other:

Storm sewer shall be protected to prevent filling or blocking with excavated materials and debris. Materials entering leaching basins, storm sewers or retention areas shall be removed and disposed of in an approved manner.

Disturbed or displaced drainage structures shall be returned to their proper place. Chipped, cracked, or broken facilities shall be replaced with RCKC approved materials.

Undermined or displaced curb and gutter shall be removed and replaced. Reinforcement steel in replacement curb and gutter shall connect to existing reinforcement steel in an approved manner.

12. Restoring Materials

The standards for restoration, as determined by the Engineer or their representative, are indicated in [Appendix E](#) and are the minimum requirements. Roads exceeding these material and design specifications shall be restored to their higher standards. Milled HMA material may be reused as aggregate base, provided the milled material approximates the gradation for MDOT 22A aggregate. See RCKC current specifications for mix designs.

13. Intent

It is the intent of these specifications that all ROW and surfaces shall be restored as soon as possible on the schedule approved by the RCKC.

14. Maintenance Certificate or Escrow

A letter of credit or cash deposit equaling 175% of the expected cost may be required.

D. Roadside Soil/Ground Cover Disturbances

Temporary, roadside impacts are anticipated. Work within and adjacent to the ROW shall comply with applicable storm water provisions and [Best Management Practice](#) measures to control soil erosion and sedimentation.

Earth changes on property that abuts the ROW shall not increase the volume or velocity of storm water disposed of in the ROW. Storm water shall be either detained on site or restricted to the original volume and rate of flow.

Grading and excavation shall be done in such a manner so as to prevent damage to roadside fixtures and features, including ditches, culverts, shoulders, curbs, basins, leaching areas, paved surfaces and utility access chambers. All debris resulting from the earth change shall be removed from the ROW.

All work shall comply with the provisions of Part 91 of the Erosion and Sedimentation Control Act of the [Natural Resources and Environmental Protection PA 451 of 1994](#), as amended and as administered by the duly authorized agent, shall appear on the plans. A copy of the SESC plan, as required by the controlling agency, shall be included with the permit request. Copy of inspection reports shall be submitted to RCKC at the same time as original report.

Work shall not damage adjacent property or result in the deposit of debris or sediment into any drainage course or the ROW. Sediment shall be removed from runoff water before it leaves the site of the earth change. Temporary or permanent facilities constructed for the conveyance of water around, through, or from the earth change area shall limit the water flow to a non-erosive velocity. All earth changes shall be designed, constructed, and completed in such a manner so that: 1) the exposed area of any disturbed land shall be limited to the shortest possible period of time, and 2) the natural flow of storm water either through or across the area is not impacted or changed unless written permission is obtained from affected property owners, including the RCKC.

Temporary SESC facilities shall be removed and earth change areas graded and stabilized with permanent soil erosion control measures pursuant to approved standards and specifications as prescribed by the EGLE. Permanent SESC measures for all slopes, channels, ditches, or any disturbed land area shall be completed within the shortest possible period of time, but not to exceed five (5) calendar days after final grading or the final earth change has been completed. If it is not possible to permanently stabilize a disturbed area after an earth change has been completed, or if significant earth change activity ceases, then temporary SESC measures shall be maintained until permanent SESC measures are in place and the area is stabilized.

The permittee undertaking soil erosion and sediment control measures, and all subsequent owners of property on which such measures have been implemented, will be responsible for the continued maintenance of the permanent SESC.

VII. ACTIONS AFFECTING TREES

These rules and regulations apply to landowners, utilities, private contractors, governmental authorities, etc., regarding trees within the ROW.

The RCKC application [Construct, Operate, Use and/or Maintain Remove Within the Right-of-Way or to Close A County Roadway](#) shall be submitted for approval prior to issuance of the permit.

A. Requirements

1. Permittee is responsible for determining if any endangered species exist in the area of work and shall be required to comply with any regulations protecting such species.
2. Applies to any tree removal, pruning, trenching or tunneling through the root system, included as part of a project or on a specific permit.
3. Permittee may be required to provide location, size, number and species of trees affected. When required, this information is to be shown on construction plans or on sheets similar to the plans; in such a way that identification can be readily made in the field. When required, the permittee shall indicate individual trees that are subject to removal, trenching, tunneling or pruning and the extent of pruning.
4. Before removing any tree measuring more than 6 inches in diameter at a point 4 feet

APPENDIX E

MINIMUM ROAD CROSS SECTION REQUIREMENTS

RESIDENTIAL ROADS (PLATS)

190 lbs / syd (1 3/4 inches) RCKC HMA Mix 36A, Mod. Wearing Course
250 lbs / syd (2 1/4 inches) RCKC HMA Mix 13A Mod. Leveling Course
8 inches CIP MDOT 22A Aggregate Base
24 inches CIP MDOT Granular Material Class III Subbase

SECONDARY ROADS (LOCAL)

220 lbs / syd (2 inches) RCKC HMA 13A Mod. or 36A Wearing Course (as determined by County Engineer)
220 lbs / syd (2 inches) RCKC HMA 13A Mod. Leveling Course
220 lbs / syd (2 inches) RCKC HMA 13A Mod. Base Course
8 inches CIP MDOT 22A Aggregate Base
24 inches CIP MDOT Granular Material Class III Subbase

Or

GRAVEL ROADS

Full surface width shall be removed to a minimum depth of 8 inches and replaced with MDOT 22A aggregate
24 inches of CIP MDOT Class III granular material

COMMERCIAL ROADS (PRIMARY)

220 lbs / syd (2 inches) RCKC HMA 13A Mod. or 36A Wearing Course (as determined by County Engineer)
220 lbs / syd (2 inches) RCKC HMA 13A Mod. Leveling Course
220 lbs / syd (2 inches) RCKC HMA 13A Mod. Base Course
8 inches CIP MDOT 22A Aggregate Base
24 inches CIP MDOT Granular Material Class III Subbase

Or

6 inches MDOT Grade P1 Reinforced Concrete Pavement
8 inches CIP MDOT 22A Aggregate Base
24 inches CIP MDOT Granular Material Class III Subbase