



Department of Management Services
Purchasing Division
241 West South Street
Kalamazoo, MI 49007-4796
Phone: 269.337.8020
Fax: 269.337.8500
www.kalamazoocity.org
purchasing@kalamazoocity.org

INVITATION FOR BIDS (IFB)

The City of Kalamazoo, Michigan is soliciting sealed bids for:

Project Name: Duke Street Resurfacing (Kilgore to Denway) Bid Reference #: 91396-017.0

IFB ISSUE DATE: February 1, 2023

BID DUE/OPENING DATE: Tuesday, February 28, 2023 at 3:00 p.m. Local Time
Facsimile Bids Will Not Be Accepted.

MAILING ADDRESS & INSTRUCTIONS

Mail To:

Purchasing Division
241 W. South Street
Kalamazoo, MI 49007

Questions for this IFB should be directed to:

Department Contact: George Waring, Public
Works Senior Civil Engineer,
waringg@kalamazoocity.org or (269) 303-7844

Include on the Envelope the Project Name and Bid Reference Number. All Envelopes Must Be Sealed.

You are invited to submit a bid for this project. Specifications, terms, conditions and instructions for submitting bids are contained herein. This Invitation for Bids with all pages, documents and attachments contained herein, or subsequently added to and made a part hereof, submitted as a fully and properly executed bid shall constitute the contract between the City and the successful bidder when approved and accepted on behalf of the City by an authorized official or agent of the City. Please review the bid document as soon as possible and note the **DEADLINE FOR QUESTIONS** in the Instructions to Bidders.

All bidders shall complete and return the Bid and Award page(s) and submit all information requested herein in order for a bid to be responsive. The bid document shall be returned in its entirety, in a properly identified and sealed envelope to the Purchasing Division at the above address. **BIDS MUST BE RECEIVED BEFORE THE DUE DATE - LATE BIDS WILL NOT BE CONSIDERED.** The City reserves the right to postpone the bid opening for its own convenience.

TABLE OF CONTENTS

Table of Contents

STATEMENT OF NO BID5

SECTION I INSTRUCTIONS FOR BIDDERS.....6

 1. EXAMINATION OF BID DOCUMENT.....6

 2. PREPARATION OF BID6

 3. EXPLANATION TO BIDDERS6

 4. CASH DISCOUNTS.....6

 5. WITHDRAWAL OF BIDS6

 6. ALTERNATE BIDS6

 7. LATE BIDS7

 8. UNIT PRICES.....7

SECTION II BID AND AWARD8

CITY OF KALAMAZOO EX-OFFENDER POLICY CHECKLIST.....10

CITY OF KALAMAZOO LOCAL PREFERENCE POLICY AND CERTIFICATION.....11

SUB-CONTRACTING INFORMATION.....13

REFERENCE QUESTIONNAIRE.....14

COVID-19 ADDENDUM #216

SECTION III CITY OF KALAMAZOO INDEMNITY AND INSURANCE17

SECTION IV SPECIAL REQUIREMENTS.....19

 1. BID BOND/GUARANTEE19

 2. WAIVERS OF LIEN19

 3. SUBCONTRACTORS.....20

 4. PREVAILING WAGES20

SECTION V SPECIAL CONDITIONS21

 1. INTENT21

 2. SCOPE OF WORK.....21

 3. UNIT PRICING22

 4. TEMPORARY UTILITIES22

 5. PROGRESS SCHEDULE.....22

 6. LIQUIDATED DAMAGES23

 7. MAINTAINING TRAFFIC23

 8. COORDINATING24

 9. WORK HOURS24

SECTION VI GENERAL CONDITIONS.....25

 1. PROJECT MANAGER’S STATUS.....25

2.	CONSTRUCTION SCHEDULE AND COORDINATION.....	25
3.	PROTECTION OF WORK	25
4.	PROTECTION OF PROPERTY	26
5.	REMOVAL OF RUBBISH	26
6.	BRICK SIDEWALK OR PAVEMENT REMOVAL	26
7.	REMOVAL OF PERMANENT TRAFFIC SIGNS AND POSTS.....	26
8.	PERMANENT TRAFFIC SIGN STAKING	26
9.	LAWN SPRINKLER SYSTEMS.....	26
10.	SALVAGING DRAINAGE STRUCTURE COVERS.....	26
11.	REMOVING AND REPLACING CURB AND GUTTER	27
12.	DRAINAGE INLET COVERS (K COVERS)	27
13.	FLY ASH USE IN CONCRETE ITEMS.....	27
14.	EXISTING WATER MAINS.....	27
15.	GRADE INTERSECTIONS	27
16.	UNDERGROUND UTILITIES	27
17.	ADJUSTING MONUMENT BOXES	27
18.	PAVEMENT REMOVAL QUANTITIES.....	27
19.	COLD MILLING	27
20.	SITE SECURITY	28
21.	SITE ACCESS	28
22.	MATERIALS INSPECTION AND RESPONSIBILITY	28
23.	GUARANTEE.....	28
24.	SAFETY	28
25.	SPECIFICATIONS FOR CONSTRUCTION.....	28
26.	QUANTITIES	28
27.	PRICE.....	28
28.	BASIS FOR PAYMENT.....	29
29.	PAY ESTIMATES	29
30.	PAYMENT TO CONTRACTOR	29
31.	INSPECTION OF WORK	29
32.	INSPECTION OF SITE	29
33.	LAYING OUT OF WORK.....	30
34.	SUPERVISION	30
35.	TARDINESS	30
36.	ADDITIONS	30
37.	INSPECTION AND TESTING	30
38.	QUESTIONS.....	30

SECTION VII TERMS AND CONDITIONS31

1. AWARD OF CONTRACT31
2. COMPLETE CONTRACT31
3. SUBCONTRACTORS – NON-ASSIGNMENT31
4. TAXES31
5. INVOICING32
6. PAYMENTS32
7. CHANGES AND/OR CONTRACT MODIFICATIONS32
8. LAWS, ORDINANCES, AND REGULATIONS32
9. RIGHT TO AUDIT33
10. HOLD HARMLESS33
11. DEFAULT33
12. TERMINATION OF CONTRACT34
13. INDEPENDENT CONTRACTOR34
14. PROJECT SUPERVISOR34
15. MEETINGS34
16. INSPECTION OF WORKSITE35
17. CONTRACT PERIOD, EXTENSIONS, CANCELLATION35

APPENDIX A NON-DISCRIMINATION CLAUSE FOR ALL CITY OF KALAMAZOO CONTRACTS
.....36

APPENDIX B PREVAILING WAGES38

APPENDIX C ADDITIONAL INFORMATION41

APPENDIX D SPECIAL PROVISIONS43

STATEMENT OF NO BID

NOTE: If you DO NOT intend to bid on this commodity or service, please complete and return this form immediately. Your response will assist us in evaluating all responses for this important project and to improve our bid solicitation process.

The Purchasing Division of the City of Kalamazoo wishes to keep its bidders list file up-to-date. If, for any reason you cannot supply the commodity/service noted in this bid solicitation, this form must be completed and returned to remain on the particular bid list for future projects of this type.

If you do not respond to this inquiry within the time set for the bid opening date and time noted, we will assume that you can no longer supply this commodity/service, and your name will be removed from this bid list.

- _____ Specifications too "tight", i.e. geared toward one brand/ manufacturer only (explain below).
- _____ Specifications are unclear (explain below).
- _____ We are unable to meet specifications.
- _____ Insufficient time to respond to the Invitation for Bid.
- _____ Our schedule would not permit us to perform.
- _____ We are unable to meet bond requirements.
- _____ We are unable to meet insurance requirements.
- _____ We do not offer this product or service.
- _____ Remove us from your bidders list for this commodity or service.
- _____ Other (specify below).

REMARKS: _____

SIGNED: _____ NAME: _____
(Type or Print)

TITLE: _____ DATE: _____

FIRM NAME: _____
(if any)

ADDRESS: _____
(Street address) (City) (State) (Zip)

PHONE: _____ FAX: _____

EMAIL: _____

SECTION I INSTRUCTIONS FOR BIDDERS

1. EXAMINATION OF BID DOCUMENT

Before submitting a bid, bidders shall carefully examine the specifications and shall fully inform themselves as to all existing conditions and limitations. The bidder shall indicate in the bid the sum to cover the cost of all items included on the bid form.

2. PREPARATION OF BID

The bid shall be legibly prepared in ink or typed. If a unit price or extension already entered by the bidder on the Bid and Award form is to be altered, it shall be crossed out and the new unit price or extension entered above or below and initialed by the bidder with ink. The bid shall be legally signed and the complete address of the bidder given thereon.

All bids shall be tightly sealed in an envelope plainly marked SEALED BID and identified by project name, bid opening date and time. Bids opened by mistake, due to improper identification, will be so documented and resealed. The Purchasing Division will maintain and guarantee confidentiality of the contents until the specified opening date and time. Bids submitted by Fax machine will not be accepted.

3. EXPLANATION TO BIDDERS

Any binding explanation desired by a bidder regarding the meaning or interpretation of the Invitation for Bid (IFB) and attachments must be requested in writing, **at least 5 business days before the bid opening (2/20/23 at 4:30 p.m.)** so a reply may reach all prospective bidders before the submission of bids. Any information given to a prospective bidder concerning the IFB will be furnished to all prospective bidders as an amendment or addendum to the IFB if such information would be prejudicial to uninformed bidders. Receipt of amendments or addenda by a bidder must be acknowledged in the bid by attachment, or by letter or fax received before the time set for opening of bids. Oral explanation or instructions given prior to the opening will not be binding.

4. CASH DISCOUNTS

Discount offered for payment of less than thirty (30) days will not be considered in evaluating bids for award. Offered discounts of less than thirty (30) days will be taken if payment is made within the discount period, even though not considered in evaluation of the bid.

5. WITHDRAWAL OF BIDS

Bids may be withdrawn in person by a bidder or authorized representative, provided their identity is made known and a receipt is signed for the bid, but only if the withdrawal is made prior to the exact time set for receipt of bid. No bid may be withdrawn for at least ninety (90) days after bid opening.

6. ALTERNATE BIDS

bidders are cautioned that any alternate bid, unless specifically requested or any changes, insertions or omissions to the terms and conditions, specifications or any other requirement of this IFB may be considered non-responsive, and at the option of the City, result in rejection of the alternate bid.

7. LATE BIDS

Any bid received at the office designated herein after the exact time specified for receipt will not be considered. (Note: The City reserves the right to consider bids that have been determined by the City to be received late due to mishandling by the City after receipt of the bid and no award has been made).

8. UNIT PRICES

If there is a discrepancy between unit prices and their extension, unit prices shall prevail.

SECTION II BID AND AWARD

The undersigned having become thoroughly familiar with all of the bid/contract documents incorporated herein, the project site and the location conditions affecting the work, hereby proposes to perform everything required to be performed in strict conformity with the requirements of these documents, and to provide and furnish all the equipment, labor and materials necessary to complete, in a professional manner, the furnishing and installing of all of the following, meeting or exceeding the specifications as set forth herein for the prices as stated below.

DUKE STREET RESURFACING (KILGORE TO DENWAY)

<u>Line</u>	<u>PayItemCode</u>	<u>Description</u>	<u>Units</u>	<u>Quantity</u>	<u>Unit Price</u>	<u>Extended Total</u>
1	1100001	Mobilization, Max 10%	LSUM	1		
2	2047001	Curb and Gutter, Rem, Special	Ft	90		
3	2050041	Subgrade Undercutting, Type II	Cyd	800		
4	2080020	Erosion Control, Inlet Protection, Fabric Drop	Ea	18		
5	4030004	Dr Structure Cover, Adj, Case 1, Modified	Ea	16		
6	4030010	Dr Structure Cover, Type Q	Ea	8		
7	4030050	Dr Structure Cover, Type K	Ea	2		
8	5010002	Cold Milling HMA Surface, 3"	Syd	9480		
9	5010002	Cold Milling HMA Surface, 1.5"	Syd	880		
10	5010033	HMA, 13A	Ton	800		
11	5012024	HMA, 36A	Ton	900		
12	8020023	Curb and Gutter, Conc, Det C4	Ft	90		
13	8110041	Pavt Mrkg, Ovly Cold Plastic, 12 inch, Crosswalk	Ft	280		
17	8110045	Pavt Mrkg, Ovly Cold Plastic, 24 inch, Stop Bar	Ft	99		
14	8110058	Pavt Mrkg, Ovly Cold Plastic, Bike, Small Sym	Ea	28		
16	8110232	Pavt Mrkg, Waterborne, 4 inch, Yellow	Ft	11000		
15	8110233	Pavt Mrkg, Waterborne, 6 inch, White	Ft	11000		
18	8127051	Traffic Maintenance and Control	LSUM	1		
19	8230391	Gate Box, Adj, Temp, Case 1	Ea	2		
20	8230411	Gate Box, Reconst, Case 1, Modified	Ea	1		
21	8230431	Gate Box, Adj, Case 1, Modified	Ea	1		
PROJECT TOTAL						

Bidder shall provide all of the information as requested herein with their bid. Failure to do so and/or failure to provide post-bid requested information may be cause for rejecting the bid as non-responsive.

After receipt of Notice to Proceed (NTP) by Contractor, work shall start within 10 days, unless otherwise agreed to by the Project Manager, and shall be completed by **September 1, 2023**.

Bidder/Contractor has examined and carefully studied the bidding documents and attachments, and acknowledges receipt of the following addenda:

Addendum No: _____

Date: _____

By my signature below, I certify that the firm bidding on this contract, when making hiring decisions, does not use a past criminal conviction as a bar to or preclude a person with a criminal conviction from being considered for employment with the bidding firm unless otherwise precluded by federal or state law. I further certify that I have read and agree to be bound by the provisions of the City's Non-Discrimination Clause found in Appendix A as updated by City Ordinance 1856.

Signed: _____ Name: _____

Title: _____

CITY OF KALAMAZOO EX-OFFENDER POLICY CHECKLIST

As part of the City’s commitment to reducing unacceptable poverty, encouraging rehabilitation, reducing recidivism and strengthening families in Kalamazoo, the City has updated its Purchasing Policy to ensure that firms with whom the City does business share in this commitment by utilizing hiring practices that do not unfairly deny people with arrest and conviction records gainful employment. *(Important: This requirement also extends to any subcontractors the bidder intends to use to fulfill the contract for goods or services being sought from the City.)*

Part I: Proof that the bidder does not inquire about an individual’s past arrest or criminal history on the bidder’s employment application form

- Attach a copy of the current application for employment being used by the bidder

Part II: Certification that the bidder does not use an individual’s past arrest or criminal history to unlawfully discriminate against them by checking one or more of the following:

- That pursuant to federal or state law bidder is precluded from hiring persons with certain criminal records from holding particular positions or engaging in certain occupations by providing a cite to the applicable statute or regulation; if checking this box, provide a citation to the applicable statute or rule upon which the bidder is relying: _____
- That bidder conducts criminal history background checks only as necessary, and only after making a conditional offer of employment; that any withdrawal of an offer of employment to an individual because of a past criminal history is job-related and consistent with business necessity after the individual has been provided an individualized assessment opportunity to review and challenge or supplement the history of past criminal conduct being relied upon by the bidder.
- That the use by bidder of criminal history background checks complies with the U.S. Equal Employment Opportunity Commission’s Enforcement Guidance on the Consideration of Arrest and Conviction Records in Employment Decisions and that the bidder has not had a determination rendered against it in past 7 years that it discriminated against a person through the use of an individual’s arrest or criminal history

I CERTIFY THAT THE ABOVE STATEMENTS ARE TRUE.

Date

Signature

Printed Name

Position

CITY OF KALAMAZOO LOCAL PREFERENCE POLICY AND CERTIFICATION

The lowest responsive Kalamazoo County bidder whose bid is not low but falls within 2% of the lowest responsive bid is afforded the opportunity to become the successful bidder if it agrees to reduce its bid to match the lowest responsive bid. The City of Kalamazoo is the sole determiner whether a bidder is responsible, qualifies as a Kalamazoo County bidder, and if its bid is responsive to the City’s specifications, terms and conditions.

If the lowest Kalamazoo County bidder chooses not to match the lowest bid, the next lowest responsive Kalamazoo County bidder whose bid falls within 2% of the lowest bid, is given the opportunity to match the lowest responsive bid.

To qualify as a Kalamazoo County bidder, the bidder must meet both the following criteria:

1. Have a physical presence in Kalamazoo County by maintaining a permanent office, factory or other facility in Kalamazoo County with employees working in Kalamazoo County.
2. Have paid real or personal property taxes related to said business to the City of Kalamazoo, County of Kalamazoo or other municipal corporation within Kalamazoo County in the previous tax year, except that a non-profit entity need not meet this requirement.

This local preference policy applies only to purchases for materials, supplies, capital outlay, and services for maintenance, repair or operation of City facilities that are over \$25,000. If more than 50% of the contract is sub-contracted to firms located outside of Kalamazoo County that bid does not qualify for the local preference policy outlined above. The local preference policy will not apply if prohibited by law. The Purchasing Agent has the authority to finally determine if the bidder qualifies as a Kalamazoo County bidder as set forth herein. The Purchasing Agent may take into account the permanency of the business in Kalamazoo, and whether the business appears to be claiming to be a Kalamazoo County business solely or primarily to qualify as a Kalamazoo County business under this Resolution, and any other material factors.

CERTIFICATION

If you qualify as a Kalamazoo County bidder and wish to be considered for the local preference provisions as provided above please certify that fact by providing the information requested below and attesting to its accuracy.

Firm Name: _____

Street Address of Business: _____

City, State, and Zip Code: _____

Number of employees working in Kalamazoo County: _____

Name the city or township to which business real and/or personal property taxes are paid or provide non-profit status: _____

The above information is accurate:

Signature: _____ Date: _____

Title: _____

Revised April 2008

REFERENCE QUESTIONNAIRE

Please answer the following questions completely.

1. Firm name: _____
2. Established: Year _____ Number of Employees: _____
3. Type of organization:
 - a. Individual: _____
 - b. Partnership: _____
 - c. Corporation: _____
 - d. Other: _____
4. Former firm name(s) if any, and year(s) in business:

5. Include at least 3 references of contracts for similar work performed over the last five (5) years. Include: owner, contact person and phone number and description of work performed.
 - a. Company Name: _____
Address: _____
Phone: _____
Contact: _____
Type of work or contract: _____
 - b. Company Name: _____
Address: _____
Phone: _____
Contact: _____
Type of work or contract: _____
 - c. Company Name: _____
Address: _____
Phone: _____
Contact: _____
Type of work or contract: _____

I hereby certify that all of the information provided is true and answered to the best of my ability.

Signed: _____ Name: _____
(type or print)

Title: _____ Date: _____

I hereby state that all of the information I have provided is true, accurate and complete. I hereby state that I have the authority to submit this bid which will become a binding contract if accepted by the City of Kalamazoo. I hereby state that I have not communicated with nor otherwise colluded with any other bidder, nor have I made any agreement with nor offered/accepted anything of value to/from an official or employee of the City of Kalamazoo that would tend to destroy or hinder free competition.

The firm's identification information provided will be used by the City for purchase orders, payment and other contractual purposes. If the contractual relationship is with, or the payment made to, another firm please provide a complete explanation on your letterhead and attach to your bid. Please provide for accounts payable purposes:

Tax Identification Number (Federal ID): _____

Remittance Address: _____

Financial Contact Name: _____ Financial Contact Phone Number: _____

Financial Contact Email Address: _____

I hereby state that I have read, understand and agree to be bound by all terms and conditions of this bid document.

SIGNED: _____ NAME: _____
(Type or Print)

TITLE: _____ DATE: _____

FIRM NAME: _____
(if any)

ADDRESS: _____
(Street address) (City) (State) (Zip)

PHONE: _____ FAX: _____

EMAIL ADDRESS: _____

FOR CITY USE ONLY - DO NOT WRITE BELOW

NOTE: This blanket addendum is for informational purposes only and does not need to be acknowledged by bidders in their submission.

COVID-19 ADDENDUM #2

January 1, 2022

**TO: ALL Prospective Bidders
PROJECT: ALL Upcoming Projects**

The purpose of this addendum is to clarify and/or modify the sealed bid delivery and bid opening process for all upcoming projects. All work affected is subject to all applicable terms and conditions of the Bidding and Contract Documents.

1. UPDATE TO SEALED BID DELIVERY AND BID OPENING POLICY:

Effective immediately and continuing until further notice, the City of Kalamazoo will return to IN-PERSON bid openings following City Hall guidelines, including Mask Mandate.

BIDS MUST BE RECEIVED BEFORE THE DUE DATE AND TIME – LATE BIDS WILL NOT BE CONSIDERED.

Bidders can submit sealed bids in one of the following ways:

- **Mail your bid**, to be received before the bid due date and time indicated in the bid document, to the City of Kalamazoo at the following address:
City of Kalamazoo
Purchasing Division
241 West South Street
Kalamazoo, MI 49007
- **Deliver your bid to the Treasurer’s Office Payment Drop Box** located in the northwest corner of City Hall before the bid due date and time indicated in the bid document.
- **Deliver your bid to City Hall In Person** before the bid due date and time indicated in the bid document.

All bids shall be tightly sealed in an envelope plainly marked SEALED BID and identified by project name, bid opening date and time. Bids opened by mistake, due to improper identification, will be so documented and resealed. The Purchasing Division will maintain and guarantee confidentiality of the contents until the specified opening date and time. Bids submitted by fax machine or email will not be accepted.

The Purchasing Division will post bid tabulations to the City of Kalamazoo website within 24 hours after the bid opening date and time at: <https://www.kalamazoo.org/bidopportunities>.

Questions regarding this sealed bid delivery and bid opening policy change related to the COVID-19 virus should be directed to the City of Kalamazoo at (269) 337-8020.

Sincerely,



Michelle Emig
Purchasing Division Manager

SECTION III CITY OF KALAMAZOO INDEMNITY AND INSURANCE

Contractor, or any of their subcontractors, shall not commence work under this contract until they have obtained the insurance required under this paragraph, and shall keep such insurance in force during the entire life of this contract. All coverage shall be with insurance companies licensed and admitted to do business in the State of Michigan and acceptable to the City of Kalamazoo within ten (10) days of the Notice of Award. The requirements below should not be interpreted to limit the liability of the Contractor. All deductibles and SIR's are the responsibility of the Contractor.

The Contractor shall procure and maintain the following insurance coverage:

Workers' Compensation Insurance including Employers' Liability Coverage, in accordance with all applicable statutes of the State of Michigan.

Commercial General Liability Insurance on an "Occurrence Basis" with limits of liability not less than \$1,000,000 per occurrence and aggregate. Coverage shall include the following extensions: (A) Contractual Liability; (B) Products and Completed Operations; (C) Independent Contractors Coverage; (D) Broad Form General Liability Extensions or equivalent, if not already included and (E) XCU coverage if the nature of the contract requires XC or U work.

Automobile Liability in accordance with all applicable statutes of the State of Michigan, with limits of liability not less than \$1,000,000 per occurrence, combined single limit for Bodily Injury, and Property Damage. Coverage shall include all owned vehicles, all non-owned vehicles, and all hired vehicles.

Additional Insured: Commercial General Liability and Automobile Liability, as described above, shall include an endorsement stating that the following shall be *Additional Insureds*: The City of Kalamazoo, all elected and appointed officials, all employees and volunteers, all boards, commissions, and/or authorities and board members, including employees and volunteers thereof. It is understood and agreed that by naming the City of Kalamazoo as additional insured, coverage afforded is considered to be primary and any other insurance the City of Kalamazoo may have in effect shall be considered secondary and/or excess.

To the fullest extent permitted by law the Contractor agrees to pay on behalf of, indemnify, and hold harmless the City of Kalamazoo, its elected and appointed officials, and employees against any claims, demands, suits, or loss, including all costs connected therewith, and for any damages which may be asserted, claimed, or recovered against or from the City of Kalamazoo, by reason of personal injury, including bodily injury or death and/or property damage, including loss of use thereof, caused in whole or part by any negligent act or omission by the Contractor, its employees, agents, or officers which arises out of, or is in any way connected or associated with, this contract.

INDEMNITY AND INSURANCE

Continued

Cancellation Notice: All policies, as described above, shall include an endorsement stating that it is understood and agreed that thirty (30) days, or ten (10) days for non-payment of premium, Advance Written Notice of Cancellation, Non-Renewal, Reduction, and/or Material Change shall be sent to: City of Kalamazoo, Purchasing Division, 241 W. South Street, Kalamazoo, MI 49007.

Proof of Insurance Coverage: The Contractor shall provide the City of Kalamazoo at the time that the contracts are returned by him/her for execution, or within 10 days of Notice of Award, whichever is earlier, a Certificate of Insurance as well as the required endorsements. In lieu of required endorsements, if applicable, a copy of the policy sections where coverage is provided for additional insured and cancellation notice would be acceptable. Copies or certified copies of all policies mentioned above shall be furnished, if so requested. If any of the above coverages expire during the term of this contract, the Contractor shall deliver renewal certificates and/or policies to City of Kalamazoo at least ten (10) days prior to the expiration date.

Scope of Coverage: The above requirements and conditions shall not be interpreted to limit the liability of the Contractor under this Contract, but shall be interpreted to provide the greatest benefit to the City and its officers and employees. The above listed coverages shall protect the Contractor, its employees, agents, representatives and subcontractors against claims arising out of the work performed. It shall be the Contractor's responsibility to provide similar insurance for each subcontractor or to provide evidence that each subcontractor carries such insurance in like amount prior to the time such subcontractor proceeds to perform under the contract.

SECTION IV SPECIAL REQUIREMENTS

1. BID BOND/GUARANTEE

The bid must be accompanied by a bid bond which shall not be less than five (5%) percent of the total amount of the bid. No bid will be considered unless it is accompanied by the required guarantee. The bid guarantee shall ensure the execution of the bid and award, and the furnishing of a performance bond and a labor and material bond (A and B below) by the successful bidder. (Contractors Note: A cashier's or certified check in lieu of a bid bond is **NOT** acceptable.)

A. PERFORMANCE BOND

A performance bond shall be furnished in the full amount of the contract ensuring the City of faithful performance of all the provisions of the contract, and the satisfactory performance of any equipment required hereunder. The bond shall also ensure the City against defective workmanship and/or materials.

B. LABOR AND MATERIAL (PAYMENT) BOND

A labor and material (payment) bond shall be furnished for the period covered by the contract, in the full amount of the contract for the protection of labor and material suppliers and sub-contractors.

Bonds shall be secured by a guaranty or a surety company listed in the latest issue of the U.S. Treasury, circular 570, and licensed to do business in the State of Michigan, and written in favor of the City of Kalamazoo. The amount of such bonds shall be within the maximum amount specified for such company in said circular 570. The bonds shall be accompanied by a power of attorney showing authority of the bonding agent to sign such bonds on behalf of the guaranty or surety company. The cost of the bonds shall be borne by the Contractor.

Failure of the Contractor to supply the required bonds within ten (10) days after Notice of Award, or within such extended period as the Purchasing Agent may agree to, shall constitute a default and the City of Kalamazoo may either award this contract to the next lowest bidder or re-advertise for bids and may charge against the Contractor for the difference between the amount of the bid and the amount for which a contract for the work is subsequently executed, irrespective of whether the amount thus due exceeds the amount of the bid bond. If a more favorable bid is received by re-advertising, the defaulting bidder shall have no claim against the City of Kalamazoo for a refund.

2. WAIVERS OF LIEN

Upon completion of all work and request for final payment, the Contractor shall furnish a 100% waiver of lien from each supplier and sub-contractor covering all items of the work. Failure to supply waivers of lien for the entire job upon completion and final payment request will be considered grounds for withholding final payment.

3. SUBCONTRACTORS

- A. Contractors shall state on the Bid and Award page any and all subcontractors to be associated with their bid, including the type work to be performed. Any and all subcontractors shall be bound by all of the terms, conditions and requirements of the contract; however, the prime contractor shall be responsible for the performance of the total work requirements.

- B. The Contractor shall cooperate with the City of Kalamazoo in meeting its commitments and goals with regard to maximum utilization of minority and women business enterprise, and shall use its best efforts to ensure that minority and women business enterprises have maximum practicable opportunity to compete for subcontract work under this agreement.

4. PREVAILING WAGES

The successful bidder will be required to comply with Section 2-125 of the Code of Ordinances of the City of Kalamazoo regarding prevailing wages and Appendix B attached, incorporated herein by reference. Special note: This provision applies only to projects in excess of \$100,000 for City (\$2,000 federal) funded projects.

The City's requirements as it relates to prevailing wages includes a meeting with the City's Purchasing Division **prior** to work and payroll and work monitoring during the duration of the contract. Please contact Purchasing at (269) 337-8020 if you have any questions regarding Davis-Bacon provisions.

SECTION V SPECIAL CONDITIONS

1. INTENT

It is the intent of these plans and specifications to provide for a general contractor who shall provide all labor, materials, tools and equipment necessary to perform in a professional manner for the **Duke Street Resurfacing (Kilgore to Denway)** project as described in the specifications and bid document.

2. SCOPE OF WORK

The scope of work for this project shall consist of effectively reconstructing Duke St from Kilgore Rd to Denway Dr. The road, Duke St, is categorized as a City local street, however, it sees some commercial traffic and is a Metro bus route. Therefore, this project is planned to incorporate a 3-inch mill and resurface with spot Subgrade Undercutting, Type II (to repair failed road subgrade). Subgrade Undercutting, Type II, will utilize 21AA aggregate, compacted to 95% density, to repair poor subgrade prior to the area being restored per standard City street section. Areas for subgrade undercutting will be marked by the Engineer following milling of the existing asphalt. The plan sheets show areas of planned subgrade undercutting based on visual inspection and information gained from pavement cores taken in 2021.

After milling, subgrade undercutting, concrete curb removal & repair, and base repair work is completed, the roadway will be repaved in accordance with the plans. Repaving work will include rolled HMA curb in accordance with the typical section as shown on the plans from STA 12+32 to 24+77. Rolled curb is included in the pay items for paving and will not be paid for separately. Rolled curb should be constructed with a paver screed attachment or device approved by the Engineer. Limits of milling and repaving will be marked as indicated on the plans.

Following the above items of work, the roadway will then be restriped in accordance with the pavement marking plan sheets (M1-M11). Pavement marking work will occur on Duke St from Kilgore Rd to Whites Rd. The typical sections, as shown on the plans, will add in bike facilities and additional crosswalk markings.

All necessary traffic control, labor, materials, tools, equipment, and other items incidental to the work being performed shall be included in the Contractor's unit price for this contract. Such items will not be bid or paid for separately but shall be included in the overall unit price.

The bidder shall furnish all labor, supervision, supplies, tools, equipment, and other means necessary or proper for performing and completing the work. The bidder shall be responsible for the cleaning up of the job site and shall repair or restore all structures and property that may be damaged or disturbed during performance of the work to the satisfaction of the Public Services Department for the City of Kalamazoo. Drainage structure covers shall be salvaged and reused if in usable condition; otherwise, they shall be replaced. Where needed, all traffic control used for such operations as defined by the MMUTCD will be the responsibility of the bidder.

The bidder shall have all work completed by September 1, 2023

3. UNIT PRICING

The unit price, including its pro rata share of overhead, multiplied by the quantity shown shall represent the total bid and shall be held firm for the life of this contract. Any bid not conforming to this requirement may be rejected as non-responsive.

4. TEMPORARY UTILITIES

- A. Temporary or construction water will NOT be available on the sites. The Contractor must provide for drinking water.
- B. Temporary toilets: To be supplied by the Contractor as may be necessary.

5. PROGRESS SCHEDULE

- 5.1 After receipt of notification by Contractor of Notice to Proceed work shall start within 10 working days.
- 5.2 Project shall have a final completion date of **September 1, 2023**.
- 5.3 Work of a similar nature may be added to this contract if agreed to by the City and the Contractor. In the event that work is added, the progress schedule for the existing work will remain unchanged. Any contract time added for additional work will be applied to that additional work only and cannot be added to items in the original contract. Any work done on the items in the original contract past the number of working days stated herein will be subject to liquidated damages regardless of any work that may be added at a later date.
- 5.4 The Contractor will be required to meet with the Public Services representatives to work out a detailed progress schedule. The schedule for this meeting will be within two weeks after contract award has been made.
- 5.5 The named sub contractor(s) for all items shall also be present at the scheduled meeting and be required to sign the Progress Schedule to indicate their approval of the scheduled dates of work set forth in the Progress Schedule. If unable to attend the scheduled meeting, the sub-contractor shall, at a minimum, sign the Progress Schedule to indicate their approval of the dates of work. MDOT Form 1130 shall be used for schedule submission and signature of all parties.
- 5.6 The Progress Schedule shall include, as a minimum, the starting and completion dates for major items, and where specified in the bid document the date the project is to be opened to traffic as well as the final project completion date specified in the bid document. The Progress Schedule shall be coordinated with all aspects of the work occurring at the site.
- 5.7 Failure on the part of the Contractor to carry out the provisions of the Progress Schedule as established may be considered sufficient cause to prevent bidding future projects until a satisfactory rate of progress is again established.
- 5.8 The starting date and the contract time to the completion date for this project may be adjusted by Public Services without imposing liquidated damages upon the receipt of satisfactory documented evidence that unforeseen delayed delivery of critical materials will prevent the orderly prosecution of the work.
- 5.9 Any request extension of the completion date and satisfactory documented evidence of unforeseen delays shall be submitted via MDOT Form 1100A – Extension of Contract Time.
- 5.10 MDOT Standard Specifications for Construction Section 501.03.I.1, Weather Limitations, shall apply.

6. LIQUIDATED DAMAGES

Liquidated Damages will be assessed per Section 108.10C of the MDOT Standard Specifications for Construction.

7. MAINTAINING TRAFFIC

- 7.1 This work shall be in accordance with the requirements of Section 812 of the MDOT Standard Specifications for Construction, the Maintaining Traffic special provision, and as specified herein. The Contractor is advised that the current Michigan Manual of Uniform Traffic Control Devices (MMUTCD) is hereby established as governing all work in connection with traffic control devices, barricade lighting, etc. required on this project.
- 7.2 The Contractor shall furnish, erect, maintain and, upon completion of the work, remove all traffic control devices and barricade lights within the project and around the perimeter of the project for the safety and protection of through and local traffic. This includes, but is not limited to: Advance, regulatory and warning signs; barricades and channeling devices at intersecting streets on which traffic is to be maintained; barricades at the ends of the project and at right of way lines for intersecting streets which are to be closed with the first usable street on each side of the project. Traffic regulators, where required by the Engineer, are included.
- 7.3 Where the existing pavement or partial widths of new pavement are to be utilized for the maintenance of through and local traffic, channelizing devices will be required at 50' intervals or as directed by the Engineer for channeling and directing traffic through the construction area.
- 7.4 Through traffic shall be maintained utilizing sidewalk closures with detours and traffic shifts per MDOT traffic and safety details.
- 7.5 Protection of all pedestrian traffic shall be maintained at all times in accordance with the MMUTCD. Type II barricades and sidewalk detour signs shall be used in accordance with the MMUTCD at all intersections and ramps. Sidewalk detours shall direct pedestrians safely around closed sidewalk locations and shall be placed at the nearest pedestrian crossing locations still open to traffic.
- 7.6 Payment for furnishing and operating all temporary traffic control devices and traffic regulators shall be paid as pay items included in this contract and shall include all the temporary traffic control measures on all road segments.
- 7.7 Under Article 812.04.D "Operated Pay Items" the term 'Relocating' shall include the relocating of the item from any street covered by the contract to any other street covered by the contract.
- 7.8 No work shall be allowed on the following dates:

4/7/23	Good Friday
5/29/23	Memorial Day Holiday
6/19/23	Juneteenth
7/4/23	Fourth of July Holiday
9/4/23	Labor Day Holiday
11/11/23	Veteran's Day
11/23/23	Thanksgiving
12/25/23	Christmas
1/1/24	New Year's Day
- 7.9 Milled surfaces will not be allowed on travel lanes for longer than 72 hours unless approved by the Project Manager. Any traffic surface within the construction area

containing a drop off at the edge of a pavement greater than two (2) inches shall not be allowed to be opened to the public without proper wedging of the edges according to the COK standard detail. Any areas not conforming to the road levelness and profile shall be signed appropriately in accordance with the MMUTCD and best management practices.

- 7.10 Once work is initiated that includes lane restrictions or detours, that work shall be continuous until complete. If work is suspended for more than three (3) continuous working days all lane restrictions and detours shall be removed at the Contractor's expense.

Special Restrictions: Access to frontage properties shall be maintained as much as practical. Emergency access shall be maintained at all times. The Contractor shall maintain two way traffic with flag control as needed when the road is restricted to only one traffic lane.

8. COORDINATING

The Contractor's attention is called to Article 104.08 of the MDOT Standard Specifications for Construction entitled "Cooperation by Contractor" and the special provisions contained within this contract.

9. WORK HOURS

All work shall be done between the hours of 7 am to 7 pm (Monday – Saturday). Work done outside of these times will be at the discretion of the Project Manager.

No work shall be done on Sunday, unless otherwise approved by the Project Manager in writing.

The Contractor shall conduct their work in such a manner that no excavations are left open overnight. If this is not possible, the Contractor shall provide and install a temporary fence to protect the excavation, at the Contractor's expense.

SECTION VI GENERAL CONDITIONS

1. PROJECT MANAGER'S STATUS

The City Engineer (Engineer) or his/her duly authorized representative shall be the City's Project Manager and shall have the duties and responsibilities as provided in the contract.

The Project Manager shall have the authority to reject any work or materials which do not conform to the contract and to decide questions or interpretations which may arise from the contract documents.

The Contractor shall immediately report to the Project Manager any questionable or obvious error or omission which may be apparent in the contract documents and shall not proceed with work until the Project Manager has resolved the error or omission.

2. CONSTRUCTION SCHEDULE AND COORDINATION

- 2.1 The Contractor shall supply the City with an agreeable construction schedule before commencing work on this contract. This schedule shall detail beginning and completion dates for each major component of the project.
- 2.2 The Contractor shall coordinate and cooperate with all other contractors who may be working on the site, to allow for the orderly progress of work being done.
- 2.3 The Contractor is required to keep the Project Manager fully informed of any proposed work which will tend to interfere with the existing operations at the site.
- 2.4 The Contractor shall schedule all work to accommodate the City's schedule. In the event the Contractor's schedule falls on weekends, nights or overtime work is required, no additional compensation will be allowed. All work shall be part of this contract without regard to when it is done.
- 2.5 The Contractor shall coordinate with other construction projects and contractors adjacent to the location of this project.
- 2.6 The Contractor shall notify, by door hanger/written flier (pre-approved by the Project Manager), affected residents and business of work and areas to be disturbed by construction at least 72 hours in advance. Work shall not commence until the affected residents/business have been notified and given advanced notice. The Contractor shall work to minimize impacts to those affected by the construction while still maintaining project schedule and objectives. For impacts to driveways or property access points that affect residents or businesses, resident/business shall be notified 24 hours in advance of the work taking place and coordinated with for parking and property access.

3. PROTECTION OF WORK

The Contractor shall maintain adequate protection of all his/her work from damage and shall protect all public and private abutting property from injury or loss arising in connection with this contract.

4. PROTECTION OF PROPERTY

- 4.1 The Contractor shall confine his/her equipment and operations to those areas of the work site necessary for the completion of the work, or as authorized by the Project Manager. The Contractor shall protect and preserve from damage any facilities, utilities or features including trees, shrubs and turf which are not required to be disturbed by the requirements of the work.
- 4.2 The Contractor shall be responsible to determine the location of and to protect from damage any utilities or other improvements.

5. REMOVAL OF RUBBISH

The Contractor shall daily remove all rubbish and accumulated materials due to his/her construction.

6. BRICK SIDEWALK OR PAVEMENT REMOVAL

When brick is removed from City of Kalamazoo sidewalk or pavement it shall be salvaged, unless otherwise stated in the contract. Brick to be salvaged shall be placed within the right-of-way (ROW) for pickup by the City. Brick shall not be placed or stored on any pavement, sidewalk, bike, or pedestrian areas but in ROW green space only; salvaged brick shall not be placed on private property without written approval given by the owner.

7. REMOVAL OF PERMANENT TRAFFIC SIGNS AND POSTS

The Contractor shall notify the Project Manager five (5) working days in advance of the time permanent signs must be removed to accommodate the construction. The Contractor shall remove and salvage any permanent signs that must be removed for construction.

8. PERMANENT TRAFFIC SIGN STAKING

The City shall stake the field locations for the new permanent traffic signs that the Contractor shall install under this contract. The Contractor shall call MISS DIG to arrange for staking prior to sign installation.

9. LAWN SPRINKLER SYSTEMS

- 9.1 Owners of known lawn sprinkler systems shall be notified by the contractor a minimum of 72 hours in advance of any work to be done that will affect those systems. Modifications to the systems are the responsibility of the owners and are not a part of this contract.
- 9.2 Owners of lawn sprinkler systems that were unknown to the contractor at the beginning of work and uncovered during the work for this contract, shall be notified as soon as possible and no later than 24 hours after discovery of the system. The Contractor shall coordinate with the owner for placement outside the immediate work area until modifications can take place. Modifications to the systems are the responsibility of the owners and are not a part of this contract.

10. SALVAGING DRAINAGE STRUCTURE COVERS

The City of Kalamazoo reserves the right to salvage any drainage structure covers or portions thereof which are to be removed as a result of work done under this contract. Any covers which are to be salvaged will be identified by the City. The contractor will set those items identified aside for pick up by City personnel.

11. REMOVING AND REPLACING CURB AND GUTTER

When the contract provides for streets to be milled and resurfaced, or when the existing base course is to remain in place, and replacement of curb and gutter is called for, milling or other surface removal operations will not take place until placement of the new curb and gutter, and adjacent concrete base course has been completed.

12. DRAINAGE INLET COVERS (K COVERS)

In compliance with the Clean Water Act, all inlet covers must have on their backs reminders against dumping waste into the drains.

13. FLY ASH USE IN CONCRETE ITEMS

The use of fly ash, as described in Section 901.07 of the MDOT Standard Specifications for Construction, shall not be allowed.

14. EXISTING WATER MAINS

The Contractor will be responsible for any damage to the existing water mains during the work required under this contract. This includes but is not limited to the construction of the proposed storm sewers, catch basins, leaching basins, leaching trenches, subgrade under drains, subgrade undercutting, full depth repairs, or other miscellaneous work.

15. GRADE INTERSECTIONS

All intersections are to be considered as complete units and their grades determined before construction is started.

16. UNDERGROUND UTILITIES

For protection of underground utilities, the Contractor shall dial Miss Dig at 1-800-482-7171 a minimum of 72 hours prior to excavating in the vicinity of utility lines. All “Miss Dig” participating members will thus be routinely notified. This does not relieve the Contractor of notifying utility owners who may not be part of the “Miss Dig” alert system.

17. ADJUSTING MONUMENT BOXES

It is the intent that all government corners on this project be preserved and that, where necessary, monument boxes be placed or adjusted whether shown or not.

18. PAVEMENT REMOVAL QUANTITIES

Pavement removal as called for in this proposal shall be at the discretion of the Project Manager. If, in his/her judgment, areas of pavement may be left in place or additional area added to provide the proper cross-section and base, adjustments can be made in the quantities.

19. COLD MILLING

In those locations where cold milling is called for and the existing curb is to remain in place, the cold milling item shall cover removal of all asphalt up to the face of the curb. Any materials which are left due to the inability of the cold milling machine to work immediately adjacent to the face of the curb will be removed to the depth indicated on the typical cross-section by other means approved by the Project Manager. Any extra work involved in removing said HMA material shall be considered incidental to the item of Cold Milling HMA Surface.

20. SITE SECURITY

The Contractor shall be responsible for job site security of all materials and tools provided by him/her and no claim for loss or damage will be considered by the City.

21. SITE ACCESS

The City will provide fair and reasonable access to the job site within the working schedules of both parties.

22. MATERIALS INSPECTION AND RESPONSIBILITY

- 22.1 The Project Manager shall have the right to inspect any materials to be used in carrying out the terms of the contract.
- 22.2 The City does not assume any responsibility for the contracted quality and standard of all materials, equipment, components or completed work furnished under this contract.
- 22.3 Any materials, equipment, components or completed work which does not comply with contract specifications, MDOT, or state codes may be rejected by the City, and shall be replaced by the Contractor at no cost to the City.
- 22.4 Any materials, equipment or components rejected shall be removed within a reasonable period of time from the premises of the City at the entire expense of the Contractor after written notice has been mailed by the City to the Contractor that such materials, equipment or components have been rejected.

23. GUARANTEE

The Contractor shall guarantee all of his/her work for a period of one (1) year following the date of final acceptance of the completed work and shall repair, replace or make good any materials or work which fail to function or perform or be found defective, without cost to the city.

24. SAFETY

The Contractor shall comply with all applicable OSHA and MIOSHA regulations.

25. SPECIFICATIONS FOR CONSTRUCTION

The items of work in this contract shall conform to the Michigan Department of Transportation (MDOT) 2020 Standard Specifications for Construction, MDOT Supplemental Specifications, and/or the City of Kalamazoo Standard Specifications unless superseded by a Special Provision contained in this document.

26. QUANTITIES

The quantities shown on the Bid and Award pages are approximate only and may be subject to increase or decrease. No guarantee of maximum or minimum is given.

27. PRICE

The unit price, including its pro rata share of overhead, multiplied by the quantity shown shall represent the total bid and shall be held firm for the life of this contract. Any bid not conforming to this requirement may be rejected as non-responsive. Special attention of all bidders is called to this provision since if conditions make it necessary to revise the quantities, no limit will be fixed for such increased or decreased quantities, nor extra compensation allowed; provided the net monetary value of all such additive and subtractive changes in quantities of such items of work, i.e., difference in cost, shall not increase or decrease the original contract price by more than

twenty five (25) percent. Some items of work might be increased beyond the 25% limitations as spelled out previously, upon mutual agreement.

28. BASIS FOR PAYMENT

Payment shall be based on the bid unit price for each work item and the approved constructed quantity for that work item. Due to potential differences in conditions between the plans and the field, final as built quantities may be different than contained in the bid document. The City does not guarantee quantities and will pay only for "as built" quantities approved by the Project Manager or his representative. Quantities in excess of those approved shall be at the Contractor's own expense, the City will not be responsible for excess quantities not approved. Should an item of work have to be redone, such as replacing new walk because the Contractor failed to adequately protect the wet concrete from rain or pedestrian or vehicular damage, such work shall be replaced at the Contractor's expense. Should changes in design result in the Project Manager directing the removal and reinstallation of already completed work prior to final completion and acceptance of the project, such removal and installation shall be paid for based on as-bid unit prices and the quantities removed and installed.

29. PAY ESTIMATES

The Contractor shall be responsible for the generation of invoices for payment. Payment will be generated by the City based upon an approved invoice. Frequency of payment shall be monthly unless agreed to otherwise by the Project Manager, with the invoiced period ending on the last day of the month. However, if a different frequency is approved by the Project Manager, it shall not exceed bi-weekly invoicing.

30. PAYMENT TO CONTRACTOR

The Project Manager will be responsible for approving all measured quantities of work. Once measured quantities are approved, the Contractor shall submit a pay invoice to the City of Kalamazoo Attn: Accounts Payable at 241 West South Street, Kalamazoo MI, 49007 or apinvoice@kalamazoocity.org. The contractor is required to meet with the Project Manager to verify final constructed quantities within 60 days of project completion. In the event of a disagreement the Project Manager's measured quantities shall be considered final.

31. INSPECTION OF WORK

The City may maintain inspectors on the job who shall, at all times, have access to work.

32. INSPECTION OF SITE

Each bidder shall visit the site of the proposed work and fully acquaint himself/herself with the existing conditions relating to construction, labor, and shall fully inform himself/herself as to the facilities involved and the difficulties and restrictions attending the performance of this contract. The bidder shall thoroughly examine and become familiar with the drawings, specifications, and all other bid/contract documents. The Contractor, by the execution of this contract, shall in no way be relieved of any obligation under it due to his failure to receive or examine any form or legal instrument, or to visit the site and acquaint himself/herself with the conditions there existing. No allowance shall be made subsequently in this connection on behalf of the Contractor for any negligence of his/her part. For inspection call the Public Services Department, Engineering Division.

33. LAYING OUT OF WORK

Before submitting a bid, the Contractor shall verify all measurements and shall be responsible for the correctness of same. No extra charge or compensation will be allowed on account of differences between actual dimensions and the measurements indicated on the drawings. Any difference that may be found shall be submitted to the City Engineer for consideration before proceeding.

34. SUPERVISION

The Contractor shall employ an experienced superintendent or foreperson on the job at all times.

35. TARDINESS

Construction delays resulting from tardiness on the part of the Contractor will be reviewed by the City in the event of any request for contract extension by the Contractor.

36. ADDITIONS

Any modification to the contract shall be subject to prior approval by the Purchasing Agent. City Commission approval may also be required.

Prices for additional work required are not requested in the itemized listing contained herein for the base project. Should additional work be authorized, compensation shall be made on the basis of price or prices to be mutually agreed upon. Such additional work shall not begin until a Change Order has been approved.

37. INSPECTION AND TESTING

The Contractor shall give the Project Manager timely notice of readiness of the work for all required inspections, tests or approvals, and shall cooperate with inspections and testing personnel to facilitate required inspections or tests.

38. QUESTIONS

Bidders shall address questions regarding the specifications to George Waring, Senior Civil Engineer, Public Works at waringg@kalamazoocity.org and/or (269) 303-7844. (This does not relieve the requirements of Page 6, Item 3.) Questions regarding terms, conditions and other related bid requirements may be addressed to Craig Hull, Buyer, at (269) 337-8444.

SECTION VII TERMS AND CONDITIONS

1. AWARD OF CONTRACT

- 1.1 This contract will be awarded to that responsible bidder whose bid, conforming to this solicitation, will be most advantageous to the City, price and other factors considered. The City reserves the right to accept or reject any or all bids and waive informalities and minor irregularities in bids received. Other factors include, as an example but not limited to, delivery time, conformance to specifications, incidental costs such as demurrage and deposits, etc.
- 1.2 Notification of award will be in writing by the Purchasing Manager. Upon notification, the Contractor shall submit to the Purchasing Division all required insurance certificates (if required) and such other documentation as may be requested or required hereunder. Upon their receipt and subsequent approval by the City, the Purchasing Manager will forward to the Contractor a written NOTICE TO PROCEED. Work shall NOT be started until such NOTICE TO PROCEED is received by the Contractor.
- 1.3 Unilateral changes in bid prices by the bidder shall not be allowed. However, the City, at its sole option, reserves the right to negotiate with bidders in the event of, but not limited to:
 - 1) No bids received;
 - 2) A single bid being received; or
 - 3) Prices quoted are over budget and/or unreasonable.

2. COMPLETE CONTRACT

This bid document together with its addenda, amendments, attachments and modifications, when executed, becomes the complete contract between the parties hereto, and no verbal or oral promises or representations made in conjunction with the negotiation of this contract shall be binding on either party.

3. SUBCONTRACTORS – NON-ASSIGNMENT

- 3.1 Bidders shall state in writing any and all sub-contractors to be associated with this bid, including the type of work to be performed. The Contractor shall cooperate with the City of Kalamazoo in meeting its commitments and goals with regard to maximum utilization of minority and women-owned business enterprises.
- 3.2 The Contractor hereby agrees and understands that the contract resulting from this solicitation shall not be transferred, assigned or sublet without prior written consent of the City of Kalamazoo.

4. TAXES

The City of Kalamazoo is exempt from all federal excise tax and state sales and use taxes.

5. INVOICING

All original invoice(s) will be sent to the Financial Services Division, 241 W. South Street, Kalamazoo, MI 49007 or via email at apinvoice@kalamazoo-city.org. The Finance Division processes payments after receipt of an original invoice from the Contractor and approval by the department. The City of Kalamazoo's policy is to pay invoice(s) within 30 days from the receipt of the original invoice, if the services or supplies are satisfactory and the proper paperwork and procedures have been followed. **In order to guarantee payment to the vendor on a timely basis, the vendor needs to receive a purchase order number before supplying the City of Kalamazoo with goods or services.** All original, and copies of original invoice(s), will clearly state which purchase order they are being billed against.

The City of Kalamazoo is a government municipality and therefore is tax exempt from all sales tax.

The vendor is responsible for supplying the Finance Division with a copy of their W9 if they are providing a service to the City of Kalamazoo.

6. PAYMENTS

- 6.1 Upon issuance of certificates of Payment by the Architect/Engineer for labor and material incorporated in the work and the materials suitably stored at the site payment shall be made up to ninety (90%) percent of the value thereof.
- 6.2 When the cumulative total of payment is equal to fifty (50%) percent of the contract sum, subsequent payments will be made in the full amount for labor and material certified by the Architect/Engineer.
- 6.3 The amount retained shall be held until final acceptance of the work, receipt of all payrolls, releases, and waiver of liens.

7. CHANGES AND/OR CONTRACT MODIFICATIONS

- 7.1 The City reserves the right to increase or decrease quantities, service or requirements, or make any changes necessary at any time during the term of this contract, or any negotiated extension thereof. Price adjustments due to any of the foregoing changes shall be negotiated and mutually agreed upon by the Contractor and the City.
- 7.2 Changes of any nature after contract award which reflect an increase or decrease in requirements or costs shall not be permitted without prior approval by the Purchasing Agent. City Commission approval may also be required.
- 7.3 ANY CHANGES PERFORMED IN ADVANCE OF PURCHASING AGENT APPROVAL, MAY BE SUBJECT TO DENIAL AND NON-PAYMENT.

8. LAWS, ORDINANCES, AND REGULATIONS

- 8.1 The Contractor shall keep himself/herself fully informed of all local, state and federal laws, ordinances and regulations in any manner affecting those engaged or employed in the work and the equipment used. Contractor and/or employees shall, at all times, serve and comply with such laws, ordinances and regulations.
- 8.2 Any permits, licenses, certificates, or fees required for the performance of the work shall be obtained and paid for by the Contractor.
- 8.3 This contract shall be governed by the laws of the State of Michigan.

9. RIGHT TO AUDIT

The City or its designee shall be entitled to audit all of the Contractor's records, and shall be allowed to interview any of the Contractor's employees, throughout the term of this contract and for a period of three years after final payment or longer if required by law to the extent necessary to adequately permit evaluation and verification of:

- A. Contractor compliance with contract requirements,
- B. Compliance with provisions for pricing change orders, invoices or claims submitted by the Contractor or any of his payees.

10. HOLD HARMLESS

If the negligent acts or omissions of the Contractor/Vendor or its employees, agents or officers, cause injury to person or property, the Contractor/Vendor shall indemnify and save harmless the City of Kalamazoo, its agents, officials, and employees against all claims, judgments, losses, damages, demands, and payments of any kind to persons or property to the extent occasioned from any claim or demand arising therefrom.

11. DEFAULT

The City may at any time, by written notice to the Contractor, terminate this contract and the Contractor's right to proceed with the work, for just cause, which shall include, but is not limited to the following:

- A. Failure to provide insurance and bonds (when called for), in the exact amounts and within the time specified or any extension thereof.
- B. Failure to make delivery of the supplies, or to perform the services within the time specified herein, or any extension thereof.
- C. The unauthorized substitution of articles for those bid and specified.
- D. Failure to make progress if such failure endangers performance of the contract in accordance with its terms.
- E. Failure to perform in compliance with any provision of the contract.
- F. Standard of Performance
 - a. Contractor guarantees the performance of the commodities, goods or services rendered herein in accordance with the accepted standards of the industry or industries concerned herein, except that if this specification calls for higher standards, then such higher standards shall be provided.
 - b. Upon notice by the City of Contractor's failure to comply with such standards or to otherwise be in default of this contract in any manner following the Notice to Proceed, Contractor shall immediately remedy said defective performance in a manner acceptable to the City. Should Contractor fail to immediately correct said defective performance, said failure shall be considered a breach of this contract and grounds for termination of the same by the City.
 - c. In the event of any breach of this contract by Contractor, Contractor shall pay any cost to the City caused by said breach including but not limited to the replacement cost of such goods or services with another Contractor.
 - d. The City reserves the right to withhold any or all payments until any defects in performance have been satisfactorily corrected.
 - e. In the event the Contractor is in breach of this contract in any manner, and such breach has not been satisfactorily corrected, the City may bar the Contractor from being awarded any future City contracts.

- G. All remedies available to the City herein are cumulative and the election of one remedy by the City shall not be a waiver of any other remedy available to the City.

12. TERMINATION OF CONTRACT

The City may, at any time and without cause, suspend the work of this contract for a period of not more than ninety days after providing notice in writing to the Contractor. The Contractor shall be allowed an adjustment in the contract price or an extension of the contract times, or both, directly attributable to the suspension if Contractor makes an approved claim.

The City may, without prejudice to any other right or remedy of the City, and with or without cause, terminate the contract by giving seven days written notice to the Contractor. In such case the Contractor shall be paid, without duplication, for the following items:

- A. Completed and acceptable work executed in accordance with the contract documents prior to the effective date of termination, including fair and reasonable sums for overhead and profit on such work;
- B. Expenses sustained prior to the effective date of termination in performing services and furnishing labor, materials or equipment as required by the contract documents in connection with uncompleted work, plus fair and reasonable sums for overhead and profit on such expenses;
- C. All documented claims, costs, losses and damages incurred in settlement of terminated contracts with Subcontractors, Suppliers and others; and
- D. Reasonable expenses directly attributable to termination.

The Contractor shall not be paid on account of loss of anticipated profits or revenue or other economic loss arising out of or resulting from such termination.

13. INDEPENDENT CONTRACTOR

At all times, the Contractor, any of his/her employees, or his/her sub-contractors and their subsequent employees shall be considered independent contractors and not as City employees. The Contractor shall exercise all supervisory control and general control over all workers' duties, payment of wages to Contractor's employees and the right to hire, fire and discipline their employees and workers. As an independent contractor, payment under this contract shall not be subject to any withholding for tax, social security or other purposes, nor shall the Contractor or his/her employees be entitled to sick leave, pension benefit, vacation, medical benefits, life insurance or workers' unemployment compensation or the like.

14. PROJECT SUPERVISOR

The Contractor shall employ an individual to act as Project Supervisor. The Project Supervisor shall be available to the Contractor's workers and the Project Manager at all times by use of a mobile phone or other reliable means. The Project Supervisor shall prepare daily work plans for the employees, monitor employee performance, attendance and punctuality; and work closely with the City's Project Manager in assuring contract compliance.

15. MEETINGS

The Contractor and/or Project Supervisor shall be available to meet with the Department Head or Project Manager at a mutually agreeable time to discuss problems, issues or concerns relative to the contract. Either party may call a meeting at any time. When such a request for a meeting is made, the meeting date shall, in no case exceed five (5) working days after the request; and, if in the sole opinion of the Department Head, the severity of the circumstance warrants, no more than one (1) working day.

16. INSPECTION OF WORKSITE

Before submitting bids or quotes for work, the Contractor shall be responsible for examining the work site and satisfying himself/herself as to the existing conditions under which he/she will be obligated to operate, or that in any way affects the work under this contract. No allowance shall be made subsequently, in behalf of the Contractor, for any negligence on his/her part.

17. CONTRACT PERIOD, EXTENSIONS, CANCELLATION

- 17.1 The contract shall be in effect for the term stated in the specifications.
- 17.2 The City may opt to extend this contract upon mutual agreement of both parties. The number of extensions shall be limited to that stated in the specifications.
- 17.3 The City may, from time to time, find it necessary to continue this contract on a month-to-month basis only, not to exceed a six (6) month period. Such month-to-month extended periods shall be by mutual agreement of both parties, with all provisions of the original contract or any extension thereof remaining in full force and effect.
- 17.4 All contracts, extensions and cost increases are subject to availability of funds and the approval of the City Commission (if required).
- 17.5 The City reserves the right to cancel the contract due to non-appropriation of funds by the City with thirty (30) days written notice.
- 17.6 Either party may terminate the contract (or any extension thereof) without cause at the end of any twelve (12) month term by giving written notice of such intent at least 60 days prior to the end of said twelve (12) month term.
- 17.7 All notices are in effect commencing with the date of mailing. Written notices may be delivered in person or sent by First Class mail; faxed or emailed to the last known address.
- 17.8 If cancellation is for default of contract due to non-performance, the contract may be canceled at any time (see Item 11, DEFAULT).

APPENDIX A NON-DISCRIMINATION CLAUSE FOR ALL CITY OF KALAMAZOO CONTRACTS

The Contractor agrees to comply with the Federal Civil Rights Act of 1964 as amended; the Federal Civil Rights Act of 1991 as amended; the Americans With Disabilities Act of 1990 as amended; the Elliott-Larson Civil Rights Act, Act. No. 453, Public Act of 1976 as amended; the Michigan Handicappers Civil Rights Act, Act No. 220, Public Act of 1976 as amended, City Ordinance 1856 and all other applicable Federal and State laws. The Contractor agrees as follows:

1. The Contractor will not discriminate against any employee or applicant for employment because of race, color, religion, national origin, sex, age, height, weight, marital status, physical or mental disability, family status, sexual orientation or gender identity that is unrelated to the individual's ability to perform the duties of the particular job or position. Such action shall include, but not be limited to the following: employment, upgrading, demotion or transfer, recruitment advertising, layoff or termination; rates of pay or other forms of compensations; and selection for training, including apprenticeship.
2. The Contractor will, in all solicitations or advertisements for employees placed by or on behalf of the Contractor, state that all qualified applicants will receive consideration for employment without regard to race, color, religion, national origin, sex, age, height, weight, marital status, physical or mental disability family status, sexual orientation or gender identity that is unrelated to the individual's ability to perform the duties of the particular job or position.
3. If requested by the City, the Contractor shall furnish information regarding practices, policies and programs and employment statistics for the Contractor and subcontractors. The Contractor and subcontractors shall permit access to all books, records and accounts regarding employment practices by agents and representatives of the City duly charged with investigative duties to assure compliance with this clause.
4. Breach of the covenants herein may be regarded as a material breach of the contract or purchasing agreement as provided in the Elliott-Larsen Civil Rights Act and City Ordinance 1856.
5. The Contractor will include or incorporate by reference the provisions of the foregoing paragraphs 1 through 4 in every subcontract or purchase order unless exempted by the rules, regulations or orders of the Michigan Civil Rights Commission* and will provide in every subcontract or purchase order that said provision will be binding upon each subcontractor or seller.
6. The Contractor will not preclude a person with a criminal conviction from being considered for employment unless otherwise precluded by federal or state law. (for contracts over \$25,000)

The Elliott-Larson Civil Rights Act, Sec. 202 of Act. No. 453 of 1976 reads in part as follows:

Sec. 202. (1) An employer shall not:

- (a) Fail or refuse to hire, or recruit, or discharge or otherwise discriminate against an individual with respect to employment, compensation, or a term condition or privilege of employment because of religion, race, color, national origin, age, sex, height, weight or marital status.
- (b) Limit, segregate or classify an employee or applicant for employment in a way which deprives or tends to deprive the employee or applicant of an employment opportunity or otherwise adversely affects the status of an employee or applicant because of religion, race, color, national origin, age, sex, height, weight or marital status.
- (c) Segregate, classify or otherwise discriminate against a person on the basis of sex with respect to a term, condition or privilege of employment, including a benefit plan or system.

* Except for contracts entered into with parties employing less than three employees.
1-2010

APPENDIX B PREVAILING WAGES

Prevailing wages are applicable to this contract, therefore, rates will apply as follows:

(XX) Project is funded by City of Kalamazoo monies and is estimated to be in excess of \$100,000.00. The applicable prevailing wage rates are attached.

Specifications for projects in which the City of Kalamazoo is party for construction, alterations and/or repair including painting and decorating of public buildings or public works in or for the City of Kalamazoo and which requires or involves the employment of mechanics and/or laborers shall contain the following provisions stating the minimum wages to be paid the various classes of laborers and mechanics for the project. Prevailing wage rates determined by the U.S. Department of Labor under Davis Bacon and related acts will be used for City of Kalamazoo construction projects.

By the incorporation of prevailing wage rates within this specification, the City of Kalamazoo stipulates that:

- ✓ Contractor or his/her subcontractor shall pay all mechanics and laborers employed directly upon the site of the work, unconditionally and not less than once a week and without subsequent deduction or rebate on any account the full amount, accrued at the time of payment, computed at wage rates as incorporated herein regardless of any contractual relationship which may be alleged to exist between the contractor or subcontractor and such laborers and mechanics;
- ✓ The scale of wages to be paid shall be posted by the contractor in a prominent and easily accessible place at the site of the work;
- ✓ The Prime Contractor and all subcontractors shall submit weekly certified payrolls documenting the hours worked and wages paid by work classification. NOTE: Contactor shall not include Social Security numbers of employees on certified payrolls.
- ✓ There may be withheld from the contractor's accrued payments the amount considered necessary by the City's Contracting Official to pay to laborers and mechanics employed by the contractor or any subcontractor on the work for the difference between the rates of wages required by the contract and the rates of wages received by such laborers and mechanics except those amounts properly deducted or refunded pursuant to the terms of the Davis-Bacon Act (USC, Title 40, Sec. 276a) and interpretations thereof.

Special Note: The City's requirements as it relates to prevailing wages includes a meeting with the City's Purchasing Agent prior to starting work and the submission of weekly certified payrolls by prime contractors and all subcontractors. The City will monitor certified payrolls, work progress, and conduct interviews with the mechanics and labors employed directly upon the site during the duration of the contract Please contact the Purchasing Department at (269) 337-8020 if you have any questions regarding prevailing wage provision.

The overtime pay to which a laborer or mechanic is entitled under this contract shall be that overtime pay to which he/she is entitled by any agreement made with the contractor or subcontractor or by any applicable provision of law; but in no event shall such amount be less than the prevailing wage in the Kalamazoo community for such overtime.

Revised 4-08



PREVAILING WAGE RATES

**DUKE STREET RESURFACING
(KILGORE TO DENWAY)**

Bid Reference #: 91396-017.0

[January 2023]

"General Decision Number: MI20230001 01/06/2023

Superseded General Decision Number: MI20220001

State: Michigan

Construction Types: Highway (Highway, Airport & Bridge xxxxx and Sewer/Incid. to Hwy.)

Counties: Michigan Statewide.

Note: Contracts subject to the Davis-Bacon Act are generally required to pay at least the applicable minimum wage rate required under Executive Order 14026 or Executive Order 13658. Please note that these Executive Orders apply to covered contracts entered into by the federal government that are subject to the Davis-Bacon Act itself, but do not apply to contracts subject only to the Davis-Bacon Related Acts, including those set forth at 29 CFR 5.1(a)(2)-(60).

<p>If the contract is entered into on or after January 30, 2022, or the contract is renewed or extended (e.g., an option is exercised) on or after January 30, 2022:</p>	<ul style="list-style-type: none"> . Executive Order 14026 generally applies to the contract. . The contractor must pay all covered workers at least \$16.20 per hour (or the applicable wage rate listed on this wage determination, if it is higher) for all hours spent performing on the contract in 2023.
<p>If the contract was awarded on or between January 1, 2015 and January 29, 2022, and the contract is not renewed or extended on or after January 30, 2022:</p>	<ul style="list-style-type: none"> . Executive Order 13658 generally applies to the contract. . The contractor must pay all covered workers at least \$12.15 per hour (or the applicable wage rate listed on this wage determination, if it is higher) for all hours spent performing on that contract in 2023.

The applicable Executive Order minimum wage rate will be adjusted annually. If this contract is covered by one of the Executive Orders and a classification considered necessary for performance of work on the contract does not appear on this wage determination, the contractor must still submit a conformance request.

Additional information on contractor requirements and worker protections under the Executive Orders is available at <http://www.dol.gov/whd/govcontracts>.

Modification Number Publication Date
 0 01/06/2023

CARP0004-004 06/01/2019

REMAINDER OF STATE

	Rates	Fringes
CARPENTER (Piledriver).....	\$ 27.62	20.59

CARP0004-005 06/01/2018		

LIVINGSTON (Townships of Brighton, Deerfield, Genoa, Hartland, Oceaola & Tyrone), MACOMB, MONROE, OAKLAND, SANILAC, ST. CLAIR AND WAYNE COUNTIES

	Rates	Fringes
CARPENTER (Piledriver).....	\$ 30.50	27.28

ELEC0017-005 06/01/2022		

STATEWIDE

	Rates	Fringes
Line Construction		
Groundman/Driver.....	\$ 29.57	7.20+32%
Journeyman Signal Tech, Communications Tech, Tower Tech & Fiber Optic Splicers.	\$ 43.90	7.20+32%
Journeyman Specialist.....	\$ 50.49	7.20+32%
Operator A.....	\$ 37.13	7.20+32%
Operator B.....	\$ 34.67	7.20+32%

Classifications

Journeyman Specialist: Refers to a crew of only one person working alone.
 Operator A: Shall be proficient in operating all power equipment including: Backhoe, Excavator, Directional Bore and Boom/Digger truck.
 Operator B: Shall be proficient in operating any 2 of the above mentioned pieces of equipment listed under Operator A.

ENGI0324-003 06/01/2022

ALCONA, ALPENA, ARENAC, BAY, CHEBOYGAN, CLARE, CLINTON, CRAWFORD, GENESEE, GLADWIN, GRATIOT, HURON, INGHAM, IOSCO, ISABELLA, JACKSON, LAPEER, LENAWE, LIVINGSTON, MACOMB, MIDLAND, MONROE, MONTMORENCY, OAKLAND, OGEMAW, OSCODA, OTSEGO, PRESQUE ISLE, ROSCOMMON, SAGINAW, ST. CLAIR, SANILAC, SHIAWASSEE, TUSCOLA, WASHTENAW AND WAYNE COUNTIES:

	Rates	Fringes
OPERATOR: Power Equipment (Steel Erection)		
GROUP 1.....	\$ 51.02	24.85
GROUP 2.....	\$ 52.02	24.85
GROUP 3.....	\$ 49.52	24.85
GROUP 4.....	\$ 50.52	24.85
GROUP 5.....	\$ 48.02	24.85
GROUP 6.....	\$ 49.02	24.85

GROUP 7.....	\$ 47.75	24.85
GROUP 8.....	\$ 48.75	24.85
GROUP 9.....	\$ 47.30	24.85
GROUP 10.....	\$ 48.30	24.85
GROUP 11.....	\$ 46.57	24.85
GROUP 12.....	\$ 47.57	24.85
GROUP 13.....	\$ 46.21	24.85
GROUP 14.....	\$ 47.21	24.85
GROUP 15.....	\$ 45.57	24.85
GROUP 16.....	\$ 42.37	24.85
GROUP 17.....	\$ 27.89	12.00
GROUP 18.....	\$ 31.38	24.85

FOOTNOTE:

Paid Holidays: New Year's Day, Memorial Day, Fourth of July, Labor Day, Thanksgiving Day and Christmas Day.

POWER EQUIPMENT OPERATOR CLASSIFICATIONS

GROUP 1: Engineer when operating combination of boom and jib 400' or longer

GROUP 2: Engineer when operating combination of boom and jib 400' or longer on a crane that requires an oiler

GROUP 3: Engineer when operating combination of boom and jib 300' or longer

GROUP 4: Engineer when operating combination of boom and jib 300' or longer on a crane that requires an oiler

GROUP 5: Engineer when operating combination of boom and jib 220' or longer

GROUP 6: Engineer when operating combination of boom and jib 220' or longer on a crane that requires an oiler

GROUP 7: Engineer when operating combination of boom and jib 140' or longer

GROUP 8: Engineer when operating combination of boom and jib 140' or longer on a crane that requires an oiler

GROUP 9: Tower crane & derrick operator (where operator's work station is 50 ft. or more above first sub-level)

GROUP 10: Tower crane & derrick operator (where operator's work station is 50 ft. or more above first sub-level) on a crane that requires an oiler

GROUP 11: Engineer when operating combination of boom and jib 120' or longer

GROUP 12: Engineer when operating combination of boom and jib 120' or longer on a crane that requires an oiler

GROUP 13: Crane operator; job mechanic and 3 drum hoist and excavator

GROUP 14: Crane operator on a crane that requires an oiler

GROUP 15: Hoisting operator; 2 drum hoist and rubber tired backhoe

GROUP 16: Forklift and 1 drum hoist

GROUP 17: Compressor or welder operator

GROUP 18: Oiler

ENGI0324-004 06/01/2022

AREA 1: ALLEGAN, BARRY, BERRIEN, BRANCH, CALHOUN, CASS, EATON, HILLSDALE, IONIA, KALAMAZOO, KENT, LAKE, MANISTEE, MASON, MECOSTA, MONTCALM, MUSKEGON, NEWAYGO, OCEANA, OSCEOLA, OTTAWA, ST. JOSEPH, VAN BUREN

AREA 2: ANTRIM, BENZIE, CHARLEVOIX, EMMET, GRAND TRAVERSE, KALKASKA, LEELANAU, MISSAUKEE AND WEXFORD COUNTIES:

	Rates	Fringes
OPERATOR: Power Equipment (Steel Erection)		
AREA 1		
GROUP 1.....	\$ 51.02	24.85
GROUP 2.....	\$ 47.75	24.85
GROUP 3.....	\$ 46.21	24.85
GROUP 4.....	\$ 42.37	24.85
GROUP 5.....	\$ 27.89	12.00
GROUP 6.....	\$ 31.38	24.85
AREA 2		
GROUP 1.....	\$ 51.02	24.85
GROUP 2.....	\$ 47.75	24.85
GROUP 3.....	\$ 46.21	24.85
GROUP 4.....	\$ 42.37	24.85
GROUP 5.....	\$ 27.89	12.00
GROUP 6.....	\$ 31.38	24.85

FOOTNOTES:

Crane operator with main boom and jib 300' or longer: \$1.50 additional to the group 1 rate. Crane operator with main boom and jib 400' or longer: \$3.00 additional to the group 1 rate.

PAID HOLIDAYS: New Year's Day, Memorial Day, Fourth of July, Labor Day, Thanksgiving Day and Christmas Day.

POWER EQUIPMENT OPERATOR CLASSIFICATIONS:

GROUP 1: Crane Operator with main boom & jib 400', 300', or 220' or longer.

GROUP 2: Crane Operator with main boom & jib 140' or longer, Tower Crane; Gantry Crane; Whirley Derrick.

GROUP 3: Regular Equipment Operator, Crane, Dozer, Loader, Hoist, Straddle Wagon, Mechanic, Grader and Hydro Excavator.

GROUP 4: Air Tugger (single drum), Material Hoist Pump 6" or over, Elevators, Brokk Concrete Breaker.

GROUP 5: Air Compressor, Welder, Generators, Conveyors

GROUP 6: Oiler and fire tender

ENGI0324-005 09/01/2022

AREA 1: GENESEE, LAPEER, LIVINGSTON, MACOMB, MONROE, OAKLAND, ST. CLAIR, WASHTENAW AND WAYNE COUNTIES

AREA 2: ALCONA, ALLEGAN, ALGER, ALPENA, ANTRIM, ARENAC, BARAGA, BARRY, BAY, BENZIE, BERRIEN, BRANCH, CALHOUN, CASS, CHARLEVOIX, CHEBOYGAN, CHIPPEWA, CLARE, CLINTON, CRAWFORD, DELTA, DICKINSON, EATON, EMMET, GLADWIN, GOGEBIC, GRAND TRAVERSE, GRATIOT, HILLSDALE, HOUGHTON, HURON, INGHAM, IONIA, IOSCO, IRON, ISABELLA, JACKSON, KALAMAZOO, KALKASKA, KENT, KWEENAW, LAKE, LEELANAU, LENAWEE, LUCE, MACKINAC, MANISTEE, MARQUETTE, MASON, MECOSTA, MENOMINEE, MIDLAND, MISSAUKEE, MONTCALM, MONTMORENCY, MUSKEGON, NEWAYGO, OCEANA, OGEMAW, ONTONAGON, OSCEOLA, OSCODA, OTSEGO, OTTAWA, PRESQUE ISLE, ROSCOMMON, SAGINAW, SANILAC, SCHOOLCRAFT, SHIAWASSEE, ST. JOSEPH, TUSCOLA, VAN BUREN AND WEXFORD COUNTIES

Rates Fringes

OPERATOR: Power Equipment
(Underground construction
(including sewer))

AREA 1:

GROUP 1.....	\$ 39.38	24.85
GROUP 2.....	\$ 34.65	24.85
GROUP 3.....	\$ 33.92	24.85
GROUP 4.....	\$ 33.35	24.85
GROUP 5.....	\$ 24.90	12.05

AREA 2:

GROUP 1.....	\$ 37.67	24.85
GROUP 2.....	\$ 32.78	24.85
GROUP 3.....	\$ 32.28	24.85
GROUP 4.....	\$ 32.00	24.85
GROUP 5.....	\$ 24.90	12.05

POWER EQUIPMENT OPERATOR CLASSIFICATIONS

GROUP 1: Backfiller tamper; Backhoe; Batch plant operator (concrete); Clamshell; Concrete paver (2 drums or larger); Conveyor loader (Euclid type); Crane (crawler, truck type or pile driving); Dozer; Dragline; Elevating grader; Endloader; Gradall (and similar type machine); Grader; Mechanic; Power shovel; Roller (asphalt); Scraper (self-propelled or tractor drawn); Side boom tractor (type D-4 or equivalent and larger); Slip form paver; Slope paver; Trencher (over 8 ft. digging capacity); Well drilling rig; Concrete pump with boom operator; Hydro Excavator

GROUP 2: Boom truck (power swing type boom); Crusher; Hoist; Pump (1 or more - 6-in. discharge or larger - gas or diesel- powered or powered by generator of 300 amperes or more - inclusive of generator); Side boom tractor (smaller than type D-4 or equivalent); Tractor (pneu-tired, other than backhoe or front end loader); Trencher (8-ft. digging capacity and smaller); Vac Truck and End dump operator;

GROUP 3: Air compressors (600 cfm or larger); Air compressors (2 or more-less than 600 cfm); Boom truck (non-swinging, non- powered type boom); Concrete breaker (self-propelled or truck mounted - includes compressor); Concrete paver (1 drum-1/2 yd. or larger); Elevator (other than passenger); Maintenance person; Pump (2 or more-4-in. up to 6-in.

discharge-gas or diesel powered - excluding submersible pumps); Pumpcrete machine (and similar equipment); Wagon drill (multiple); Welding machine or generator (2 or more-300 amp. or larger - gas or diesel powered)

GROUP 4: Boiler; Concrete saw (40 hp or over); Curing machine (self-propelled); Farm tractor (with attachment); Finishing machine (concrete); Hydraulic pipe pushing machine; Mulching equipment; Pumps (2 or more up to 4-in. discharge, if used 3 hours or more a day, gas or diesel powered - excluding submersible pumps); Roller (other than asphalt); Stump remover; Trencher (service); Vibrating compaction equipment, self-propelled (6 ft. wide or over); Sweeper (Wayne type); Water wagon and Extend-a boom forklift

Group 5: Fire Person, Oiler

ENGI0324-006 06/01/2022

GENESEE, MACOMB, MONROE, OAKLAND, WASHTENAW, WAYNE, ALCONA, ALGER, ALLEGAN, ALPENA, ANTRIM, ARENAC, BARAGA, BARRY, BAY, BENZIE, BERRIEN, BRANCH, CALHOUN, CASS, CHARLEVOIX, CHEBOYGAN, CHIPPEWA, CLARE, CLINTON, CRAWFORD, DELTA, DICKINSON, EATON, EMMET, GLADWIN, GOGEBIC, GRAND TRAVERSE, GRATIOT, HILLSDALE, HOUGHTON, HURON, INGHAM, IONIA, IOSCO, IRON, ISABELLA, JACKSON, KALAMAZOO, KALKASKA, KENT, KEWEENAW, LAKE, LAPEER, LEELANAU, LENAWEE, LIVINGSTON, LUCE, MACKINAC, MANISTEE, MARQUETTE, MASON, MECOSTA, MENOMINEE, MIDLAND, MISSAUKEE, MONTCALM, MONTMORENCY, MUSKEGON, NEWAYGO, OCEANA, OGEAW, ONTONAGON, OSCEOLA, OSCODA, OTSEGO, OTTAWA, PRESQUE ISLE, ROSCOMMON, SAGINAW, ST. CLARE, ST. JOSEPH, SANILAC, SCHOOLCRAFT, SHIAWASSEE, TUSCOLA, VAN BUREN AND WEXFORD COUNTIES

Rates Fringes

Power equipment operators:
(AIRPORT, BRIDGE & HIGHWAY
CONSTRUCTION)

GROUP 1.....	\$ 38.86	24.85
GROUP 2.....	\$ 32.13	24.85
GROUP 3.....	\$ 31.57	24.85
GROUP 4.....	\$ 31.40	24.85

POWER EQUIPMENT OPERATOR CLASSIFICATIONS

GROUP 1: Asphalt plant operator; Crane operator (does not include work on bridge construction projects when the crane operator is erecting structural components); Dragline operator; Shovel operator; Locomotive operator; Paver operator (5 bags or more); Elevating grader operator; Pile driving operator; Roller operator (asphalt); Blade grader operator; Trenching machine operator (ladder or wheel type); Auto-grader; Slip form paver; Self-propelled or tractor-drawn scraper; Conveyor loader operator (Euclid type); Endloader operator (1 yd. capacity and over); Bulldozer; Hoisting engineer; Tractor operator; Finishing machine operator (asphalt); Mechanic; Pump operator (6-in. discharge or over, gas, diesel powered or generator of 300 amp. or larger); Shouldering or gravel distributing machine operator (self-propelled); Backhoe (with over 3/8 yd. bucket); Side boom tractor (type D-4 or equivalent or larger); Tube finisher (slip form paving); Gradall (and similar type machine); Asphalt paver (self-propelled);

Asphalt planer (self-propelled); Batch plant (concrete-central mix); Slurry machine (asphalt); Concrete pump (3 in. and over); Roto-mill; Swinging boom truck (over 12 ton capacity); Hydro demolisher (water blaster); Farm-type tractor with attached pan; Vacuum truck operator; Batch Plant (concrete dry batch); Concrete Saw Operator (40h.p. or over; Tractor Operator (farm type); Finishing Machine Operator (concrete); Grader Operator (self-propelled fine grade or form (concrete)).

GROUP 2: Screening plant operator; Washing plant operator; Crusher operator; Backhoe (with 3/8 yd. bucket or less); Side boom tractor (smaller than D-4 type or equivalent); Sweeper (Wayne type and similar equipment); Greese Truck; Air Compressor Operator (600 cu.ft. per min or more); Air Compressor Operator (two or more, less than 600 cfm);

GROUP 3: Boiler fire tender; Tractor operator (farm type with attachment); Concrete Breaker; Wagon Drill Operator;

GROUP 4: Oiler; Fire tender; Trencher (service); Flexplane operator; Cleftplane operator; Boom or winch hoist truck operator; Endloader operator *under 1 yd. capacity); Roller Operator (other than asphalt); Curing equipment operator (self-propelled); Power bin operator; Plant drier (6 ft. wide or over); Guard post driver operator (power driven); All mulching equipment; Stump remover; Concrete pump (under 3-in.); Mesh installer (self-propelled); End dump; Skid Steer.

 ENGI0324-007 05/01/2022

ALGER, BARAGA, CHIPPEWA, DELTA, DICKINSON, GOGEBIC, HOUGHTON, IRON, KEWEENAW, LUCE, MACKINAC MARQUETTE, MENOMINEE, ONTONAGON AND SCHOOLCRAFT COUNTIES:

	Rates	Fringes
OPERATOR: Power Equipment		
(Steel Erection)		
Compressor, welder and forklift.....	\$ 37.40	24.60
Crane operator, main boom & jib 120' or longer.....	\$ 43.87	24.60
Crane operator, main boom & jib 140' or longer.....	\$ 44.17	24.60
Crane operator, main boom & jib 220' or longer.....	\$ 44.17	24.60
Mechanic with truck and tools.....	\$ 43.00	24.60
Oiler and fireman.....	\$ 35.86	24.60
Regular operator.....	\$ 41.22	24.60

 ENGI0324-008 10/01/2020

ALCONA, ALGER, ALLEGAN, ALPENA, ANTRIM, ARENAC, BARAGA, BARRY, BAY, BENZIE, BERRIEN, BRANCH, CALHOUN, CASS, CHARLEVOIX, CHEBOYGAN, CHIPPEWA, CLARE, CLINTON, CRAWFORD, DELTA, DICKINSON, EATON, EMMET, GENESEE, GLADWIN, GOGEBIC, GRAND TRAVERSE, GRATIOT, HILLSDALE, HOUGHTON, HURON, INGHAM, IONIA, IOSCO, IRON, ISABELLA, JACKSON, KALAMAZOO, KALKASKA, KENT, KEWEENAW, LAKE, LAPEER, LEELANAU, LENAWEE, LIVINGSTON, LUCE, MACKINAC, MACOMB, MANISTEE, MARQUETTE, MASON, MECOSTA,

MENOMINEE, MIDLAND, MISSAUKEE, MONTCALM, MONTMORENCY, MONROE, MUSKEGON, NEWAYGO, OAKLAND, OCEANA, OGEMAW, ONTONAGON, OSCEOLA, OSCODA, OTSEGO, OTTAWA, PRESQUE ISLE, ROSCOMMON, SAGINAW, ST. CLARE, ST. JOSEPH, SANILAC, SCHOOLCRAFT, SHIAWASSEE, TUSCOLA, VAN BUREN, WASHTENAW, WAYNE AND WEXFORD COUNTIES

Rates Fringes

OPERATOR: Power Equipment (Sewer Relining)

GROUP 1.....	\$ 35.37	14.31
GROUP 2.....	\$ 33.33	14.31

SEWER RELINING CLASSIFICATIONS

GROUP 1: Operation of audio-visual closed circuit TV system, including remote in-ground cutter and other equipment used in connection with the CCTV system

GROUP 2: Operation of hot water heaters and circulation systems, water jetters and vacuum and mechanical debris removal systems

ENGI0325-012 05/01/2022

Rates Fringes

Power equipment operators - gas distribution and duct installation work:

GROUP 1.....	\$ 34.83	24.85
GROUP 2.....	\$ 32.55	24.85

SCOPE OF WORK: The construction, installation, treating and reconditioning of pipelines transporting gas vapors within cities, towns, subdivisions, suburban areas, or within private property boundaries, up to and including private meter settings of private industrial, governmental or other premises, more commonly referred to as ""distribution work,"" starting from the first metering station, connection, similar or related facility, of the main or cross country pipeline and including duct installation.

Group 1: Backhoe, crane, grader, mechanic, dozer (D-6 equivalent or larger), side boom (D-4 equivalent or larger), trencher(except service), endloader (2 yd. capacity or greater).

GROUP 2: Dozer (less than D-6 equivalent), endloader (under 2 yd. capacity), side boom (under D-4 capacity), backfiller, pumps (1 or 2 of 6-inch discharge or greater), boom truck (with powered boom), tractor (wheel type other than backhoe or front endloader). Tamper (self-propelled), boom truck (with non-powered boom), concrete saw (20 hp or larger), pumps (2 to 4 under 6-inch discharge), compressor (2 or more or when one is used continuously into the second day) and trencher(service). Oiler, hydraulic pipe pushing machine, grease person and hydrostatic testing operator.

IRON0008-007 06/01/2022

ALGER, BARAGA, CHIPPEWA, DELTA, DICKINSON, GOGEBIC, HOUGHTON,

IRON, KEWEENAW, LUCE, MACKINAC MARQUETTE, MENOMINEE, ONTONAGON AND SCHOOLCRAFT COUNTIES:

	Rates	Fringes
Ironworker - pre-engineered metal building erector.....	\$ 23.70	6.95
IRONWORKER		
General contracts		
\$10,000,000 or greater.....	\$ 38.14	28.70
General contracts less than \$10,000,000.....	\$ 38.14	28.70

Paid Holidays: New Year's Day, Memorial Day, July 4th, Labor Day, Thanksgiving Day & Christmas Day.

IRON0025-002 06/01/2021

ALCONA, ALPENA, ARENAC, BAY, CHEBOYGAN, CLARE, CLINTON, CRAWFORD, GENESEE, GLADWIN, GRATIOT, HURON, INGHAM, IOSCO, ISABELLA, JACKSON, LAPEER, LIVINGSTON, MACOMB, MIDLAND, MONTMORENCY, OAKLAND, OGEMAW, OSCODA, OTSEGO, PRESQUE ISLE, ROSCOMMON, SAGINAW, SANILAC, SHIAWASSEE, ST. CLAIR, TUSCOLA, WASHTENAW AND WAYNE COUNTIES:

	Rates	Fringes
Ironworker - pre-engineered metal building erector		
Alcona, Alpena, Arenac, Cheboygan, Clare, Clinton, Crawford, Gladwin, Gratiot, Huron, Ingham, Iosco, Isabella, Jackson, Lapeer, Livingston (west of Burkhardt Road), Montmorency, Ogemaw, Oscoda, Otsego, Presque Isle, Roscommon, Sanilac, Shiawassee, Tuscola & Washtenaw (west of U.S. 23).	\$ 24.26	22.11
Bay, Genesee, Lapeer, Livingston (east of Burkhardt Road), Macomb, Midland, Oakland, Saginaw, St. Clair, The University of Michigan, Washtenaw (east of U.S. 23) & Wayne...	\$ 25.48	23.11
IRONWORKER		
Ornamental and Structural...	\$ 36.77	29.03
Reinforcing.....	\$ 32.99	30.76

IRON0055-005 07/01/2022

LENAWEE AND MONROE COUNTIES:

	Rates	Fringes
IRONWORKER		
Pre-engineered metal buildings.....	\$ 23.59	19.35
All other work.....	\$ 33.00	27.20

 IRON0292-003 06/01/2020

BERRIEN AND CASS COUNTIES:

	Rates	Fringes
IRONWORKER (Including pre-engineered metal building erector).....	\$ 31.75	22.84

 IRON0340-001 06/19/2022

ALLEGAN, ANTRIM, BARRY, BENZIE, BRANCH, CALHOUN, CHARLEVOIX, EATON, EMMET, GRAND TRAVERSE, HILLSDALE, IONIA, KALAMAZOO, KALKASKA, KENT, LAKE, LEELANAU, MANISTEE, MASON, MECOSTA, MISSAUKEE, MONTCALM, MUSKEGON, NEWAYGO, OCEANA, OSCEOLA, OTTAWA, ST. JOSEPH, VAN BUREN AND WEXFORD COUNTIES:

	Rates	Fringes
IRONWORKER (Including pre-engineered metal building erector).....	\$ 24.59	25.43

 LAB00005-006 10/01/2022

	Rates	Fringes
Laborers - hazardous waste abatement: (ALCONA, ALPENA, ANTRIM, BENZIE, CHARLEVOIX, CHEBOYGAN, CRAWFORD, EMMET, GRAND TRAVERSE, IOSCO, KALKASKA, LEELANAU, MISSAUKEE, MONTMORENCY, OSCODA, OTSEGO, PRESQUE ISLE AND WEXFORD COUNTIES - Zone 10)		
Levels A, B or C.....	\$ 17.45	12.75
class b.....	\$ 18.64	12.90
Work performed in conjunction with site preparation not requiring the use of personal protective equipment;		
Also, Level D.....	\$ 16.45	12.75
class a.....	\$ 17.64	12.90

Zone 10

Laborers - hazardous waste abatement: (ALGER, BARAGA, CHIPPEWA, DELTA, DICKINSON, GOGEBIC, HOUGHTON, IRON, KEWEENAW, LUCE, MACKINAC, MARQUETTE, MENOMINEE, ONTONAGON AND SCHOOLCRAFT COUNTIES - Zone 11)		
Levels A, B or C.....	\$ 25.18	12.90
Work performed in conjunction with site preparation not requiring the use of personal protective equipment;		
Also, Level D.....	\$ 22.58	12.90

Laborers - hazardous waste abatement: (ALLEGAN, BARRY, BERRIEN, BRANCH, CALHOUN, CASS, IONIA COUNTY (except the city of Portland); KALAMAZOO, KENT, LAKE, MANISTEE, MASON, MECOSTA, MONTCALM, MUSKEGON, NEWAYGO, OCEANA, OSCEOLA, OTTAWA, ST. JOSEPH AND VAN BUREN COUNTIES - Zone 9)	
Levels A, B or C.....\$ 21.88	13.26
Work performed in conjunction with site preparation not requiring the use of personal protective equipment;	
Also, Level D.....\$ 20.80	12.90
Laborers - hazardous waste abatement: (ARENAC, BAY, CLARE, GLADWIN, GRATIOT, HURON, ISABELLA, MIDLAND, OGEAW, ROSCOMMON, SAGINAW AND TUSCOLA COUNTIES - Zone 8)	
Levels A, B or C.....\$ 23.74	12.95
Work performed in conjunction with site preparation not requiring the use of personal protective equipment;	
Also, Level D.....\$ 20.80	12.90
Laborers - hazardous waste abatement: (CLINTON, EATON AND INGHAM COUNTIES; IONIA COUNTY (City of Portland); LIVINGSTON COUNTY (west of Oak Grove Rd., including the City of Howell) - Zone 6)	
Levels A, B or C.....\$ 26.33	12.95
Work performed in conjunction with site preparation not requiring the use of personal protective equipment;	
Also, Level D.....\$ 24.64	12.90
Laborers - hazardous waste abatement: (GENESEE, LAPEER AND SHIAWASSEE COUNTIES - Zone 7)	
Levels A, B or C.....\$ 24.20	13.80
Work performed in conjunction with site preparation not requiring the use of personal protective equipment;	
Also, Level D.....\$ 23.20	13.80
Laborers - hazardous waste abatement: (HILLSDALE, JACKSON AND LENAWEЕ COUNTIES - Zone 4)	
Levels A, B or C.....\$ 27.13	14.95
Work performed in conjunction with site preparation not requiring the use of personal	

protective equipment;		
Also, Level D.....	\$ 24.17	12.90
Laborers - hazardous waste abatement: (LIVINGSTON COUNTY (east of Oak Grove Rd. and south of M-59, excluding the city of Howell); AND WASHTENAW COUNTY - Zone 3)		
Levels A, B or C.....	\$ 29.93	14.20
Work performed in conjunction with site preparation not requiring the use of personal protective equipment;		
Also, Level D.....	\$ 28.93	14.20
Laborers - hazardous waste abatement: (MACOMB AND WAYNE COUNTIES - Zone 1)		
Levels A, B or C.....	\$ 29.93	16.90
Work performed in conjunction with site preparation not requiring the use of personal protective equipment;		
Also, Level D.....	\$ 28.93	16.90
Laborers - hazardous waste abatement: (MONROE COUNTY - Zone 4)		
Levels A, B or C.....	\$ 31.75	14.90
Work performed in conjunction with site preparation not requiring the use of personal protective equipment;		
Also, Level D.....	\$ 31.75	14.90
Laborers - hazardous waste abatement: (OAKLAND COUNTY and the Northeast portion of LIVINGSTON COUNTY bordered by Oak Grove Road on the West and M-59 on the South - Zone 2)		
Level A, B, C.....	\$ 29.93	16.90
Work performed in conjunction with site preparation not requiring the use of personal protective equipment;		
Also, Level D.....	\$ 28.93	16.90
Laborers - hazardous waste abatement: (SANILAC AND ST. CLAIR COUNTIES - Zone 5)		
Levels A, B or C.....	\$ 26.21	16.62
Work performed in conjunction with site preparation not requiring the use of personal protective equipment;		
Also, Level D.....	\$ 24.75	16.35

LAB00259-001 09/01/2022

AREA 1: MACOMB, OAKLAND AND WAYNE COUNTIES
 AREA 2: ALCONA, ALGER, ALLEGAN, ALPENA, ANTRIM, ARENAC, BARAGA, BARRY, BAY, BENZIE, BERRIEN, BRANCH, CALHOUN, CASS, CHARLEVOIX,

CHEBOYGAN, CHIPPEWA, CLARE, CLINTON, CRAWFORD, DELTA, DICKINSON, EATON, EMMET, GENESEE, GLADWIN, GOGEBIC, GRAND TRAVERSE, GRATIOT, HILLSDALE, HOUGHTON, HURON, INGHAM, IONIA, IOSCO, IRON, ISABELLA, JACKSON, KALAMAZOO, KALKASKA, KENT, KEWEENAW, LAKE, LAPEER, LEELANAU, LENAWEE, LIVINGSTON, LUCE, MACKINAC, MANISTEE, MARQUETTE, MASON, MECOSTA, MENOMINEE, MIDLAND, MISSAUKEE, MONROE, MONTCALM, MONTMORENCY, MUSKEGON, NEWAYGO, OCEANA, OGEMAW, ONTONAGON, OSCEOLA, OSCODA, OTSEGO, OTTAWA, PRESQUE ISLE, ROSCOMMON, SAGINAW, ST. CLARE, ST. JOSEPH, SANILAC, SCHOOLCRAFT, SHIAWASSEE, TUSCOLA, VAN BUREN, WASHTENAW AND WEXFORD COUNTIES

	Rates	Fringes
Laborers - tunnel, shaft and caisson:		
AREA 1		
GROUP 1.....	\$ 23.62	16.95
GROUP 2.....	\$ 23.73	19.95
GROUP 3.....	\$ 23.79	16.95
GROUP 4.....	\$ 23.97	16.95
GROUP 5.....	\$ 24.22	16.95
GROUP 6.....	\$ 24.55	16.95
GROUP 7.....	\$ 17.83	16.95
AREA 2		
GROUP 1.....	\$ 25.15	12.95
GROUP 2.....	\$ 25.24	12.95
GROUP 3.....	\$ 25.34	12.95
GROUP 4.....	\$ 25.50	12.95
GROUP 5.....	\$ 25.76	12.95
GROUP 6.....	\$ 26.07	12.95
GROUP 7.....	\$ 18.34	12.95

SCOPE OF WORK: Tunnel, shaft and caisson work of every type and description and all operations incidental thereto, including, but not limited to, shafts and tunnels for sewers, water, subways, transportation, diversion, sewerage, caverns, shelters, aquafers, reservoirs, missile silos and steel sheeting for underground construction.

TUNNEL LABORER CLASSIFICATIONS

GROUP 1: Tunnel, shaft and caisson laborer, dump, shanty, hog house tender, testing (on gas) and watchman

GROUP 2: Manhole, headwall, catch basin builder, bricklayer tender, mortar machine and material mixer

GROUP 3: Air tool operator (jackhammer, bush hammer and grinder), first bottom, second bottom, cage tender, car pusher, carrier, concrete, concrete form, concrete repair, cement invert laborer, cement finisher, concrete shoveler, conveyor, floor, gasoline and electric tool operator, gunite, grout operator, welder, heading dinky person, inside lock tender, pea gravel operator, pump, outside lock tender, scaffold, top signal person, switch person, track, tugger, utility person, vibrator, winch operator, pipe jacking, wagon drill and air track operator and concrete saw operator (under 40 h.p.)

GROUP 4: Tunnel, shaft and caisson mucker, bracer, liner plate, long haul dinky driver and well point

GROUP 5: Tunnel, shaft and caisson miner, drill runner, key

board operator, power knife operator, reinforced steel or mesh (e.g. wire mesh, steel mats, dowel bars, etc.)

GROUP 6: Dynamite and powder

GROUP 7: Restoration laborer, seeding, sodding, planting, cutting, mulching and top soil grading; and the restoration of property such as replacing mailboxes, wood chips, planter boxes, flagstones, etc.

LAB00334-001 09/01/2021

	Rates	Fringes
Laborers - open cut:		
ZONE 1 - MACOMB, OAKLAND AND WAYNE COUNTIES:		
GROUP 1.....	\$ 23.47	16.95
GROUP 2.....	\$ 23.58	16.95
GROUP 3.....	\$ 23.63	16.95
GROUP 4.....	\$ 23.71	16.95
GROUP 5.....	\$ 23.77	16.95
GROUP 6.....	\$ 21.22	16.95
GROUP 7.....	\$ 17.84	16.95
ZONE 2 - LIVINGSTON COUNTY (east of M-151 (Oak Grove Rd.)); MONROE AND WASHTENAW COUNTIES:		
GROUP 1.....	\$ 24.80	12.95
GROUP 2.....	\$ 24.91	12.95
GROUP 3.....	\$ 25.03	12.95
GROUP 4.....	\$ 25.10	12.95
GROUP 5.....	\$ 25.25	12.95
GROUP 6.....	\$ 22.55	12.95
GROUP 7.....	\$ 19.19	12.95
ZONE 3 - CLINTON, EATON, GENESEE, HILLSDALE AND INGHAM COUNTIES; IONIA COUNTY (City of Portland); JACKSON, LAPEER AND LENAWEЕ COUNTIES; LIVINGSTON COUNTY (west of M-151 Oak Grove Rd.); SANILAC, ST. CLAIR AND SHIAWASSEE COUNTIES:		
GROUP 1.....	\$ 22.99	12.95
GROUP 2.....	\$ 23.13	12.95
GROUP 3.....	\$ 23.25	12.95
GROUP 4.....	\$ 23.30	12.95
GROUP 5.....	\$ 23.44	12.95
GROUP 6.....	\$ 20.74	12.95
GROUP 7.....	\$ 17.89	12.95
ZONE 4 - ALCONA, ALLEGAN, ALPENA, ANTRIM, ARENAC, BARRY, BAY, BENZIE, BERRIEN, BRANCH, CALHOUN, CASS, CHARLEVOIX, CHEBOYGAN, CLARE, CRAWFORD, EMMET, GLADWIN, GRAND TRAVERSE, GRATIOT AND HURON COUNTIES; IONIA COUNTY (EXCEPT THE CITY OF PORTLAND); IOSCO,		

ISABELLA, KALAMAZOO,
 KALKASKA, KENT,
 LAKE, LEELANAU, MANISTEE,
 MASON, MECOSTA, MIDLAND,
 MISSAUKEE, MONTCALM,
 MONTMORENCY, MUSKEGON,
 NEWAYGO, OCEANA, OGEMAW,
 OSCEOLA, OSCODA, OTSEGO,
 OTTAWA, PRESQUE ISLE,
 ROSCOMMON, SAGINAW, ST.
 JOSEPH, TUSCOLA, VAN BUREN
 AND WEXFORD COUNTIES:

GROUP 1.....	\$ 22.02	12.95
GROUP 2.....	\$ 22.15	12.95
GROUP 3.....	\$ 22.26	12.95
GROUP 4.....	\$ 22.33	12.95
GROUP 5.....	\$ 22.45	12.95
GROUP 6.....	\$ 19.67	12.95
GROUP 7.....	\$ 18.01	12.95

ZONE 5 - ALGER, BARAGA,
 CHIPPEWA, DELTA,
 DICKINSON, GOGEBIC,
 HOUGHTON, IRON,
 KEWEENAW, LUCE, MACKINAC,
 MARQUETTE, MENOMINEE,
 ONTONAGON AND SCHOOLCRAFT
 COUNTIES:

GROUP 1.....	\$ 22.24	12.95
GROUP 2.....	\$ 22.38	12.95
GROUP 3.....	\$ 22.51	12.95
GROUP 4.....	\$ 22.56	12.95
GROUP 5.....	\$ 22.61	12.95
GROUP 6.....	\$ 19.99	12.95
GROUP 7.....	\$ 18.10	12.95

SCOPE OF WORK:

Open cut construction work shall be construed to mean work which requires the excavation of earth including industrial, commercial and residential building site excavation and preparation, land balancing, demolition and removal of concrete and underground appurtenances, grading, paving, sewers, utilities and improvements; retention, oxidation, flocculation and irrigation facilities, and also including but not limited to underground piping, conduits, steel sheeting for underground construction, and all work incidental thereto, and general excavation. For all areas except the Upper Peninsula, open cut construction work shall also be construed to mean waterfront work, piers, docks, seawalls, breakwalls, marinas and all incidental work. Open cut construction work shall not include any structural modifications, alterations, additions and repairs to buildings, or highway work, including roads, streets, bridge construction and parking lots or steel erection work and excavation for the building itself and back filling inside of and within 5 ft. of the building and foundations, footings and piers for the building. Open cut construction work shall not include any work covered under Tunnel, Shaft and Caisson work.

OPEN CUT LABORER CLASSIFICATIONS

GROUP 1: Construction laborer

GROUP 2: Mortar and material mixer, concrete form person,

signal person, well point person, manhole, headwall and catch basin builder, headwall, seawall, breakwall and dock builder

GROUP 3: Air, gasoline and electric tool operator, vibrator operator, driller, pump person, tar kettle operator, bracer, rodder, reinforced steel or mesh person (e.g., wire mesh, steel mats, dowel bars, etc.), welder, pipe jacking and boring person, wagon drill and air track operator and concrete saw operator (under 40 h.p.), windlass and tugger person and directional boring person

GROUP 4: Trench or excavating grade person

GROUP 5: Pipe layer (including crock, metal pipe, multi-plate or other conduits)

GROUP 6: Grouting man, audio-visual television operations and all other operations in connection with closed circuit television inspection, pipe cleaning and pipe relining work and the installation and repair of water service pipe and appurtenances

GROUP 7: Restoration laborer, seeding, sodding, planting, cutting, mulching and top soil grading; and the restoration of property such as replacing mailboxes, wood chips, planter boxes, flagstones, etc.

LAB00465-001 06/01/2022

LABORER: Highway, Bridge and Airport Construction

AREA 1: GENESEE, MACOMB, MONROE, OAKLAND, WASHTENAW AND WAYNE COUNTIES

AREA 2: ALLEGAN, BARRY, BAY, BERRIEN, BRANCH, CALHOUN, CASS, CLINTON, EATON, GRATIOT, HILLSDALE, HURON, INGHAM, JACKSON, KALAMAZOO, LAPEER, LENAWEE, LIVINGSTON, MIDLAND, MUSKEGON, SAGINAW, SANILAC, SHIAWASSEE, ST. CLAIR, ST. JOSEPH, TUSCOLA AND VAN BUREN COUNTIES

AREA 3: ALCONA, ALPENA, ANTRIM, ARENAC, BENZIE, CHARLEVOIX, CHEBOYGAN, CLARE, CRAWFORD, EMMET, GLADWIN, GRAND TRAVERSE, IONIA, IOSCO, ISABELLA, KALKASKA, KENT, LAKE, LEELANAU, MANISTEE, MASON, MECOSTA, MISSAUKEE, MONTCALM, MONTMORENCY, NEWAYGO, OCEANA, OGEMAW, OSCEOLA, OSCODA, OTSEGO, OTTAWA, PRESQUE ISLE, ROSCOMMON AND WEXFORD COUNTIES

AREA 4: ALGER, BARAGA, CHIPPEWA, DELTA, DICKINSON, GOGEBIC, HOUGHTON, IRON, KEWEENAW, LUCE, MACKINAC, MARQUETTE, MENOMINEE, ONTONAGON AND SCHOOLCRAFT COUNTIES

	Rates	Fringes
LABORER (AREA 1)		
GROUP 1.....	\$ 32.02	13.95
GROUP 2.....	\$ 32.15	13.95
GROUP 3.....	\$ 32.33	13.95
GROUP 4.....	\$ 32.41	13.95
GROUP 5.....	\$ 32.62	13.95
GROUP 6.....	\$ 32.92	13.95
LABORER (AREA 2)		
GROUP 1.....	\$ 26.92	12.90

GROUP 2.....	\$ 27.12	12.90
GROUP 3.....	\$ 27.36	12.90
GROUP 4.....	\$ 27.71	12.90
GROUP 5.....	\$ 27.58	12.90
GROUP 6.....	\$ 27.92	12.90
LABORER (AREA 3)		
GROUP 1.....	\$ 26.22	12.90
GROUP 2.....	\$ 26.43	12.90
GROUP 3.....	\$ 26.72	12.90
GROUP 4.....	\$ 27.16	12.90
GROUP 5.....	\$ 26.78	12.90
GROUP 6.....	\$ 27.21	12.90
LABORER (AREA 4)		
GROUP 1.....	\$ 26.22	12.90
GROUP 2.....	\$ 26.43	12.90
GROUP 3.....	\$ 26.72	12.90
GROUP 4.....	\$ 27.16	12.90
GROUP 5.....	\$ 26.78	12.90
GROUP 6.....	\$ 27.21	12.90

LABORER CLASSIFICATIONS

GROUP 1: Asphalt shoveler or loader; asphalt plant misc.; burlap person; yard person; dumper (wagon, truck, etc.); joint filling laborer; miscellaneous laborer; unskilled laborer; sprinkler laborer; form setting laborer; form stripper; pavement reinforcing; handling and placing (e.g., wire mesh, steel mats, dowel bars); mason's tender or bricklayer's tender on manholes; manhole builder; headwalls, etc.; waterproofing, (other than buildings) seal coating and slurry mix, shoring, underpinning; pressure grouting; bridge pin and hanger removal; material recycling laborer; horizontal paver laborer (brick, concrete, clay, stone and asphalt); ground stabilization and modification laborer; grouting; waterblasting; top person; railroad track and trestle laborer; carpenters' tender; guard rail builders' tender; earth retention barrier and wall and M.S.E. wall installer's tender; highway and median installer's tender (including sound, retaining, and crash barriers); fence erector's tender; asphalt raker tender; sign installer; remote control operated equipment.

GROUP 2: Mixer operator (less than 5 sacks); air or electric tool operator (jackhammer, etc.); spreader; boxperson (asphalt, stone, gravel); concrete paddler; power chain saw operator; paving batch truck dumper; tunnel mucker (highway work only); concrete saw (under 40 h.p.) and dry pack machine; roto-mill grounds person.

GROUP 3: Tunnel miner (highway work only); finishers tenders; guard rail builders; highway and median barrier installer; earth retention barrier and wall and M.S.E. wall installer's (including sound, retaining and crash barriers); fence erector; bottom person; powder person; wagon drill and air track operator; diamond and core drills; grade checker; certified welders; curb and side rail setter's tender.

GROUP 4: Asphalt raker

GROUP 5: Pipe layers, oxy-gun

GROUP 6: Line-form setter for curb or pavement; asphalt screed checker/screw man on asphalt paving machines.

LABO1076-005 04/01/2022

MICHIGAN STATEWIDE

	Rates	Fringes
LABORER (DISTRIBUTION WORK)		
Zone 1.....	\$ 25.17	13.32
Zone 2.....	\$ 23.47	13.40
Zone 3.....	\$ 21.60	13.45
Zone 4.....	\$ 20.97	13.43
Zone 5.....	\$ 21.00	13.40

DISTRIBUTION WORK - The construction, installation, treating and reconditioning of distribution pipelines transporting coal, oil, gas or other similar materials, vapors or liquids, including pipelines within private property boundaries, up to and including the meter settings on residential, commercial, industrial, institutional, private and public structures. All work covering pumping stations and tank farms not covered by the Building Trades Agreement. Other distribution lines with the exception of sewer, water and cable television are included.

Underground Duct Layer Pay: \$.40 per hour above the base pay rate.

Zone 1 - Macomb, Oakland and Wayne

Zone 2 - Monroe and Washtenaw

Zone 3 - Bay, Genesee, Lapeer, Midland, Saginaw, Sanilac, Shiawassee and St. Clair

Zone 4 - Alger, Baraga, Chippewa, Delta, Dickinson, Gogebic, Houghton, Iron, Keweenaw, Luce, Mackinac, Marquette, Menominee, Ontonagon and Schoolcraft

Zone 5 - Remaining Counties in Michigan

PAIN0022-002 07/01/2008

HILLSDALE, JACKSON AND LENAWEE COUNTIES; LIVINGSTON COUNTY (east of the eastern city limits of Howell, not including the city of Howell, north to the Genesee County line and south to the Washtenaw County line); MACOMB, MONROE, OAKLAND, WASHTENAW AND WAYNE COUNTIES:

	Rates	Fringes
PAINTER.....	\$ 25.06	14.75

FOOTNOTES: For all spray work and journeyman rigging for spray work, also blowing off, \$0.80 per hour additional (applies only to workers doing rigging for spray work on off the floor work. Does not include setting up or moving rigging on floor surfaces, nor does it apply to workers engaged in covering up or tending spray equipment. For all sandblasting and spray work performed on highway bridges, overpasses, tanks or steel, \$0.80 per hour additional. For all brushing, cleaning and other preparatory work (other than spraying or steeplejack work) at scaffold heights of fifty (50) feet from the ground or higher, \$0.50 per hour additional. For all preparatorial work and painting performed on open steel under forty (40) feet when no scaffolding is involved, \$0.50 per hour additional. For all

swing stage work-window jacks and window belts-exterior and interior, \$0.50 per hour additional. For all spray work and sandblaster work to a scaffold height of forty (40) feet above the floor level, \$0.80 per hour additional. For all preparatorial work and painting on all highway bridges or overpasses up to forty (40) feet in height, \$0.50 per hour additional. For all steeplejack work performed where the elevation is forty (40) feet or more, \$1.25 per hour additional.

PAIN0312-001 06/01/2018

EXCLUDES: ALLEGAN COUNTY (Townships of Dorr, Fillmore, Heath, Hopkins, Laketown, Leighton, Manlius, Monterey, Overisel, Salem, Saugatuck and Wayland); INCLUDES: Barry, Berrien, Branch, Calhoun, Cass, Hillsdale, Kalamazoo, St. Joseph, Van Buren

	Rates	Fringes
PAINTER		
Brush and roller.....	\$ 23.74	13.35
Spray, Sandblast, Sign		
Painting.....	\$ 24.94	13.35

PAIN0845-003 05/10/2018

CLINTON COUNTY; EATON COUNTY (does not include the townships of Bellevue and Olivet); INGHAM COUNTY; IONIA COUNTY (east of Hwy. M 66); LIVINGSTON COUNTY (west of the eastern city limits of Howell, including the city of Howell, north to the Genesee County line and south to the Washtenaw County line); AND SHIAWASSEE COUNTY (Townships of Bennington, Laingsbury and Perry):

	Rates	Fringes
PAINTER.....	\$ 25.49	13.74

PAIN0845-015 05/10/2018

MUSKEGON COUNTY; NEWAYGO COUNTY (except the Townships of Barton, Big Prairie, Brooks, Croton, Ensley, Everett, Goodwell, Grant, Home, Monroe, Norwich and Wilcox); OCEANA COUNTY; OTTAWA COUNTY (except the townships of Allendale, Blendone, Chester, Georgetown, Holland, Jamestown, Olive, Park, Polkton, Port Sheldon, Tallmadge, Wright and Zeeland):

	Rates	Fringes
PAINTER.....	\$ 25.49	13.74

PAIN0845-018 05/10/2018

ALLEGAN COUNTY (Townships of Dorr, Fillmore, Heath, Hopkins, Laketown, Leighton, Manlius, Monterey, Overisel, Salem, Saugatuck and Wayland); IONIA COUNTY (west of Hwy. M-66); KENT, MECOSTA AND MONTCALM COUNTIES; NEWAYGO COUNTY (Townships of Barton, Big Prairie, Brooks, Croton, Ensley, Everett, Goodwell, Grant, Home, Monroe, Norwich and Wilcox); OSCEOLA COUNTY (south of Hwy. #10); OTTAWA COUNTY (Townships of Allendale, Blendone,

Chester, Georgetown, Holland, Jamestown, Olive, Park, Polkton, Port Sheldon, Tallmadge, Wright and Zeeland):

	Rates	Fringes
PAINTER.....	\$ 25.49	13.74

FOOTNOTES: Lead abatement work: \$1.00 per hour additional.

PAIN1011-003 06/02/2022

ALGER, BARAGA, CHIPPEWA, DELTA, DICKINSON, GOGEBIC, HOUGHTON, IRON, KEWEENAW, LUCE, MACKINAC, MARQUETTE, MENOMINEE, ONTONAGON AND SCHOOLCRAFT COUNTIES:

	Rates	Fringes
PAINTER.....	\$ 24.66	14.99

FOOTNOTES: High pay (bridges, overpasses, watertower): 30 to 80 ft.: \$.65 per hour additional. 80 ft. and over: \$1.30 per hour additional.

PAIN1474-002 06/01/2010

HURON COUNTY; LAPEER COUNTY (east of Hwy. M-53); ST. CLAIR, SANILAC AND TUSCOLA COUNTIES:

	Rates	Fringes
PAINTER.....	\$ 23.79	12.02

FOOTNOTES: Lead abatement work: \$1.00 per hour additional. Work with any hazardous material: \$1.00 per hour additional. Sandblasting, steam cleaning and acid cleaning: \$1.00 per hour additional. Ladder work at or above 40 ft., scaffold work at or above 40 ft., swing stage, boatswain chair, window jacks and all work performed over a falling height of 40 ft.: \$1.00 per hour additional. Spray gun work, pick pullers and those handling needles, blowing off by air pressure, and any person rigging (setting up and moving off the ground): \$1.00 per hour additional. Steeplejack, tanks, gas holders, stacks, flag poles, radio towers and beacons, power line towers, bridges, etc.: \$1.00 per hour additional, paid from the ground up.

PAIN1803-003 06/01/2019

ALCONA, ALPENA, ANTRIM, ARENAC, BAY, BENZIE, CHARLEVOIX, CHEBOYGAN, CLARE, CRAWFORD, EMMET, GLADWIN, GRAND TRAVERSE, GRATIOT, IOSCO, ISABELLA, KALKASKA, LAKE, LEELANAU, MANISTEE, MASON, MIDLAND, MISSAUKEE, MONTMORENCY AND OGEMAW COUNTIES; OSCEOLA COUNTY (north of Hwy. #10); OSCODA, OTSEGO, PRESQUE ISLE, ROSCOMMON, SAGINAW AND WEXFORD COUNTIES:

	Rates	Fringes
PAINTER		
Work performed on water,		

bridges over water or moving traffic, radio and powerline towers, elevated tanks, steeples, smoke stacks over 40 ft. of falling heights, recovery of lead-based paints and any work associated with industrial plants, except maintenance of industrial plants.....	\$ 25.39	14.68
All other work, including maintenance of industrial plant.....	\$ 25.39	14.68

FOOTNOTES: Spray painting, sandblasting, blowdown associated with spraying and blasting, water blasting and work involving a swing stage, boatswain chair or spider: \$1.00 per hour additional. All work performed inside tanks, vessels, tank trailers, railroad cars, sewers, smoke stacks, boilers or other spaces having limited egress not including buildings, opentop tanks, pits, etc.: \$1.25 per hour additional.

 PLAS0514-001 06/01/2018

ZONE 1: GENESEE, LIVINGSTON, MACOMB, MONROE, OAKLAND, SAGINAW, WASHTENAW AND WAYNE COUNTIES

ZONE 2: ALCONA, ALGER, ALLEGAN, ALPENA, ANTRIM, ARENAC, BARAGA, BARRY, BAY, BENZIE, BERRIEN, BRANCH, CALHOUN, CASS, CHARLEVOIX, CHEBOYGAN, CHIPPEWA, CLARE, CLINTON, CRAWFORD, DELTA, DICKINSON, EATON, EMMET, GLADWIN, GOGEBIC, GRAND TRAVERSE, GRATIOT, HILLSDALE, HOUGHTON, HURON, INGHAM, IONIA, IOSCO, IRON, ISABELLA, JACKSON, KALAMAZOO, KALKASKA, KENT, KEWEENAW, LAKE, LAPEER, LEELANAU, LENAWEE, LUCE, MACKINAC, MANISTEE, MARQUETTE, MASON, MECOSTA, MENOMINEE, MIDLAND, MISSAUKEE, MONTCALM, MONTMORENCY, MUSKEGON, NEWAYGO, OCEANA, OGEMAW, ONTONAGON, OSCEOLA, OSCODA, OTSEGO, OTTAWA, PRESQUE ISLE, ROSCOMMON, SANILAC, SCHOOLCRAFT, SHIAWASSEE, ST. CLAIR, ST. JOSEPH, TUSCOLA, VAN BUREN AND WEXFORD COUNTIES

	Rates	Fringes
CEMENT MASON/CONCRETE FINISHER		
ZONE 1.....	\$ 31.47	13.81
ZONE 2.....	\$ 29.97	13.81

 PLUM0190-003 05/01/2015

ALCONA, ALGER, ALLEGAN, ALPENA, ANTRIM, ARENAC, BARAGA, BARRY, BAY, BENZIE, BERRIEN, BRANCH, CALHOUN, CASS, CHARLEVOIX, CHEBOYGAN, CHIPPEWA, CLARE, CLINTON, CRAWFORD, DELTA, DICKINSON, EATON, EMMET, GENESEE, GLADWIN, GOGEBIC, GRAND TRAVERSE, GRATIOT, HILLSDALE, HOUGHTON, HURON, INGHAM, IONIA, IOSCO, IRON, ISABELLA, JACKSON, KALAMAZOO, KALKASKA, KENT, KEWEENAW, LAKE, LAPEER, LEELANAU, LENAWEE, LIVINGSTON, LUCE, MACKINAC, MACOMB, MANISTEE, MARQUETTE, MASON, MECOSTA, MENOMINEE, MIDLAND, MISSAUKEE, MONTCALM, MONTMORENCY, MONROE, MUSKEGON, NEWAYGO, OAKLAND, OCEANA, OGEMAW, ONTONAGON, OSCEOLA, OSCODA, OTSEGO, OTTAWA, PRESQUE ISLE, ROSCOMMON, SAGINAW, ST. CLARE, ST. JOSEPH, SANILAC, SCHOOLCRAFT, SHIAWASSEE, TUSCOLA, VAN BUREN, WASHTENAW, WAYNE AND WEXFORD COUNTIES

Rates Fringes

Plumber/Pipefitter - gas distribution pipeline: Welding in conjunction with gas distribution pipeline work.....	\$ 33.03	20.19
All other work:.....	\$ 24.19	12.28

TEAM0007-004 06/01/2020

AREA 1: ALCONA, ALGER, ALLEGAN, ALPENA, ANTRIM, ARENAC, BARAGA, BARRY, BAY, BENZIE, BERRIEN, BRANCH, CALHOUN, CASS, CHARLEVOIX, CHEBOYGAN, CHIPPEWA, CLARE, CLINTON, CRAWFORD, DELTA, DICKINSON, EATON, EMMET, GLADWIN, GOGEBIC, GRAND TRAVERSE, GRATIOT, HILLSDALE, HOUGHTON, HURON, INGHAM, IONIA, IOSCO, IRON, ISABELLA, JACKSON, KALAMAZOO, KALKASKA, KENT, KEWEENAW, LAKE, LAPEER, LEELANAU, LENAWEE, LUCE, MACKINAC, MANISTEE, MARQUETTE, MASON, MECOSTA, MENOMINEE, MIDLAND, MISSAUKEE, MONTCALM, MONTMORENCY, MUSKEGON, NEWAYGO, OCEANA, OGEMAW, ONTONAGON, OSCEOLA, OSCODA, OTSEGO, OTTAWA, PRESQUE ISLE, ROSCOMMON, SAGINAW, SANILAC, SCHOOLCRAFT, SHIAWASSEE, ST. CLAIR, ST. JOSEPH, TUSCOLA, VAN BUREN AND WEXFORD COUNTIES

AREA 2: GENESEE, LIVINGSTON, MACOMB, MONROE, OAKLAND, WASHTENAW AND WAYNE COUNTIES

Rates Fringes

TRUCK DRIVER		
AREA 1		
Euclids, double bottoms and lowboys.....	\$ 28.05	.50 + a+b
Trucks under 8 cu. yds.....	\$ 27.80	.50 + a+b
Trucks, 8 cu. yds. and over.....	\$ 27.90	.50 + a+b
AREA 2		
Euclids, double bottomms and lowboys.....	\$ 24.895	.50 + a+b
Euclids, double bottoms and lowboys.....	\$ 28.15	.50 + a+b
Trucks under 8 cu. yds.....	\$ 27.90	.50 + a+b
Trucks, 8 cu. yds. and over.....	\$ 28.00	.50 + a+b

Footnote:
a. \$470.70 per week
b. \$68.70 daily

TEAM0247-004 04/01/2013

AREA 1: ALCONA, ALGER, ALLEGAN, ALPENA, ANTRIM, ARENAC, BARAGA, BARRY, BAY, BENZIE, BERRIEN, BRANCH, CALHOUN, CASS, CHARLEVOIX, CHEBOYGAN, CHIPPEWA, CLARE, CLINTON, CRAWFORD, DELTA, DICKINSON, EATON, EMMET, GLADWIN, GOGEBIC, GRAND TRAVERSE, GRATIOT, HILLSDALE, HOUGHTON, HURON, INGHAM, IONIA, IOSCO, IRON, ISABELLA, JACKSON, KALAMAZOO, KALKASKA, KENT, KEWEENAW, LAKE, LAPEER, LEELANAU, LENAWEE, LUCE, MACKINAC, MANISTEE, MARQUETTE, MASON, MECOSTA, MENOMINEE, MIDLAND, MISSAUKEE, MONTCALM, MONTMORENCY, MUSKEGON, NEWAYGO, OCEANA, OGEMAW, ONTONAGON, OSCEOLA, OSCODA, OTSEGO, OTTAWA, PRESQUE ISLE, ROSCOMMON, SANILAC, SCHOOLCRAFT, SHIAWASSEE, SAGINAW, ST.

CLAIR, ST. JOSEPH, TUSCOLA, VAN BUREN AND WEXFORD COUNTIES

AREA 2: GENESEE, LIVINGSTON, MACOMB, MONROE, OAKLAND, WASHTENAW AND WAYNE COUNTIES

	Rates	Fringes
Sign Installer		
AREA 1		
GROUP 1.....	\$ 21.78	11.83
GROUP 2.....	\$ 25.27	11.8375
AREA 2		
GROUP 1.....	\$ 22.03	11.83
GROUP 2.....	\$ 25.02	11.8375

FOOTNOTE:

a. \$132.70 per week, plus \$17.80 per day.

SIGN INSTALLER CLASSIFICATIONS:

GROUP 1: performs all necessary labor and uses all tools required to construct and set concrete forms required in the installation of highway and street signs

GROUP 2: performs all miscellaneous labor, uses all hand and power tools, and operates all other equipment, mobile or otherwise, required for the installation of highway and street signs

TEAM0247-010 04/01/2018

AREA 1: LAPEER AND SHIAWASSEE COUNTIES

AREA 2: GENESEE, MACOMB, MONROE, OAKLAND, ST. CLAIR, WASHTENAW AND WAYNE COUNTIES

	Rates	Fringes
TRUCK DRIVER (Underground construction)		
AREA 1		
GROUP 1.....	\$ 23.82	19.04
GROUP 2.....	\$ 23.91	19.04
GROUP 3.....	\$ 24.12	19.04
AREA 2		
GROUP 1.....	\$ 24.12	19.04
GROUP 2.....	\$ 24.26	19.04
GROUP 3.....	\$ 24.45	19.04

PAID HOLIDAYS: New Year's Day, Memorial Day, Fourth of July, Labor Day, Thanksgiving Day and Christmas Day.

SCOPE OF WORK: Excavation, site preparation, land balancing, grading, sewers, utilities and improvements; also including but not limited to, tunnels, underground piping, retention, oxidation, flocculation facilities, conduits, general excavation and steel sheeting for underground construction. Underground construction work shall not include any structural modifications, alterations, additions and repairs to buildings or highway work, including roads,

streets, bridge construction and parking lots or steel erection.

TRUCK DRIVER CLASSIFICATIONS

GROUP 1: Truck driver on all trucks (EXCEPT dump trucks of 8 cubic yards capacity or over, pole trailers, semis, low boys, Euclid, double bottom and fuel trucks)

GROUP 2: Truck driver on dump trucks of 8 cubic yards capacity or over, pole trailers, semis and fuel trucks

GROUP 3: Truck driver on low boy, Euclid and double bottom

SUMI2002-001 05/01/2002

	Rates	Fringes
Flag Person.....	\$ 10.10 **	0.00
LINE PROTECTOR (ZONE 1: GENESEE, MACOMB, MONROE, OAKLAND, WASHTENAW AND WAYNE)....	\$ 22.89	13.45
LINE PROTECTOR (ZONE 2: STATEWIDE (EXCLUDING GENESEE, MACOMB, MONROE, OAKLAND, WASHTENAW AND WAYNE).....	\$ 20.19	13.45
Pavement Marking Machine (ZONE 1: GENESEE, MACOMB, MONROE, OAKLAND, WASHTENAW AND WAYNE COUNTIES) Group 1.....	\$ 30.52	13.45
Pavement Marking Machine (ZONE 1: GENESEE, MACOMB, MONROE, OAKLAND, WASHTENAW AND WAYNE) Group 2.....	\$ 27.47	13.45
Pavement Marking Machine (ZONE 2: STATEWIDE (EXCLUDING GENESEE, MACOMB, MONROE, OAKLAND, WASHTENAW AND WAYNE COUNTIES) Group 1.....	\$ 26.92	13.45
Pavement Marking Machine (ZONE 2: STATEWIDE (EXCLUDING GENESEE, MACOMB, MONROE, OAKLAND, WASHTENAW AND WAYNE) Group 2.....	\$ 24.23	13.45

WORK CLASSIFICATIONS:

PAVEMENT MARKER GROUP 1: Drives or operates a truck mounted striper, grinder, blaster, groover, or thermoplastic melter for the placement or removal of temporary or permanent pavement markings or markers.

PAVEMENT MARKER GROUP 2: Performs all functions involved for the placement or removal of temporary or permanent pavement markings or markers not covered by the classification of

Pavement Marker Group 1 or Line Protector.

LINE PROTECTOR: Performs all operations for the protection or removal of temporary or permanent pavement markings or markers in a moving convoy operation not performed by the classification of Pavement Marker Group 1. A moving convoy operation is comprised of only Pavement Markers Group 1 and Line Protectors.

WELDERS - Receive rate prescribed for craft performing operation to which welding is incidental.

=====
** Workers in this classification may be entitled to a higher minimum wage under Executive Order 14026 (\$16.20) or 13658 (\$12.15). Please see the Note at the top of the wage determination for more information.

Note: Executive Order (EO) 13706, Establishing Paid Sick Leave for Federal Contractors applies to all contracts subject to the Davis-Bacon Act for which the contract is awarded (and any solicitation was issued) on or after January 1, 2017. If this contract is covered by the EO, the contractor must provide employees with 1 hour of paid sick leave for every 30 hours they work, up to 56 hours of paid sick leave each year. Employees must be permitted to use paid sick leave for their own illness, injury or other health-related needs, including preventive care; to assist a family member (or person who is like family to the employee) who is ill, injured, or has other health-related needs, including preventive care; or for reasons resulting from, or to assist a family member (or person who is like family to the employee) who is a victim of, domestic violence, sexual assault, or stalking. Additional information on contractor requirements and worker protections under the EO is available at <https://www.dol.gov/agencies/whd/government-contracts>.

Unlisted classifications needed for work not included within the scope of the classifications listed may be added after award only as provided in the labor standards contract clauses (29CFR 5.5 (a) (1) (ii)).

The body of each wage determination lists the classification and wage rates that have been found to be prevailing for the cited type(s) of construction in the area covered by the wage determination. The classifications are listed in alphabetical order of ""identifiers"" that indicate whether the particular rate is a union rate (current union negotiated rate for local), a survey rate (weighted average rate) or a union average rate (weighted union average rate).

Union Rate Identifiers

A four letter classification abbreviation identifier enclosed in dotted lines beginning with characters other than ""SU"" or ""UAVG"" denotes that the union classification and rate were prevailing for that classification in the survey. Example: PLUM0198-005 07/01/2014. PLUM is an abbreviation identifier of

the union which prevailed in the survey for this classification, which in this example would be Plumbers. 0198 indicates the local union number or district council number where applicable, i.e., Plumbers Local 0198. The next number, 005 in the example, is an internal number used in processing the wage determination. 07/01/2014 is the effective date of the most current negotiated rate, which in this example is July 1, 2014.

Union prevailing wage rates are updated to reflect all rate changes in the collective bargaining agreement (CBA) governing this classification and rate.

Survey Rate Identifiers

Classifications listed under the ""SU"" identifier indicate that no one rate prevailed for this classification in the survey and the published rate is derived by computing a weighted average rate based on all the rates reported in the survey for that classification. As this weighted average rate includes all rates reported in the survey, it may include both union and non-union rates. Example: SULA2012-007 5/13/2014. SU indicates the rates are survey rates based on a weighted average calculation of rates and are not majority rates. LA indicates the State of Louisiana. 2012 is the year of survey on which these classifications and rates are based. The next number, 007 in the example, is an internal number used in producing the wage determination. 5/13/2014 indicates the survey completion date for the classifications and rates under that identifier.

Survey wage rates are not updated and remain in effect until a new survey is conducted.

Union Average Rate Identifiers

Classification(s) listed under the UAVG identifier indicate that no single majority rate prevailed for those classifications; however, 100% of the data reported for the classifications was union data. EXAMPLE: UAVG-OH-0010 08/29/2014. UAVG indicates that the rate is a weighted union average rate. OH indicates the state. The next number, 0010 in the example, is an internal number used in producing the wage determination. 08/29/2014 indicates the survey completion date for the classifications and rates under that identifier.

A UAVG rate will be updated once a year, usually in January of each year, to reflect a weighted average of the current negotiated/CBA rate of the union locals from which the rate is based.

WAGE DETERMINATION APPEALS PROCESS

1.) Has there been an initial decision in the matter? This can be:

- * an existing published wage determination
- * a survey underlying a wage determination
- * a Wage and Hour Division letter setting forth a position on a wage determination matter
- * a conformance (additional classification and rate) ruling

On survey related matters, initial contact, including requests for summaries of surveys, should be with the Wage and Hour National Office because National Office has responsibility for the Davis-Bacon survey program. If the response from this initial contact is not satisfactory, then the process described in 2.) and 3.) should be followed.

With regard to any other matter not yet ripe for the formal process described here, initial contact should be with the Branch of Construction Wage Determinations. Write to:

Branch of Construction Wage Determinations
Wage and Hour Division
U.S. Department of Labor
200 Constitution Avenue, N.W.
Washington, DC 20210

2.) If the answer to the question in 1.) is yes, then an interested party (those affected by the action) can request review and reconsideration from the Wage and Hour Administrator (See 29 CFR Part 1.8 and 29 CFR Part 7). Write to:

Wage and Hour Administrator
U.S. Department of Labor
200 Constitution Avenue, N.W.
Washington, DC 20210

The request should be accompanied by a full statement of the interested party's position and by any information (wage payment data, project description, area practice material, etc.) that the requestor considers relevant to the issue.

3.) If the decision of the Administrator is not favorable, an interested party may appeal directly to the Administrative Review Board (formerly the Wage Appeals Board). Write to:

Administrative Review Board
U.S. Department of Labor
200 Constitution Avenue, N.W.
Washington, DC 20210

4.) All decisions by the Administrative Review Board are final.

=====

END OF GENERAL DECISIO"

**APPENDIX C
ADDITIONAL INFORMATION**



**THE CITY OF KALAMAZOO
DEPARTMENT OF PUBLIC SERVICES
ENGINEERING DIVISION**

PLAN SHEETS

**DUKE STREET RESURFACING
(KILGORE TO DENWAY)**

Bid Reference #: 91396-017.0



CITY OF KALAMAZOO
DEPARTMENT OF PUBLIC SERVICES
ENGINEERING

DUKE STREET RECONSTRUCTION PROJECT

FROM KILGORE TO DENWAY

WITH PAVEMENT MARKINGS FROM KILGORE TO WHITES

INDEX OF SHEETS

- 1. TITLE SHEET
- 2. GENERAL NOTES
- 3. LEGEND SHEET
- 4.-9. PLAN SHEETS
- M1-M11 PAVEMENT MARKINGS

UTILITY CONTACTS

ELECTRIC
CONSUMERS ENERGY CO.
2500 E. CORK ST.
KALAMAZOO, MI 49001
ANDRE TAYLOR (269) 337-2245
andre.taylor@cmsenergy.com

TELEPHONE
AT&T
2919 MILLCORK AVE.
KALAMAZOO, MI 49001
PHIL BARDOCZ (269) 823-3339
phil.bardocz@att.net

GAS
CONSUMERS ENERGY CO.
2500 E. CORK ST.
KALAMAZOO, MI 49001
KYLE OAK (248) 249-7175
kyle.oak@cmsenergy.com

WATER & SEWER
CITY OF KALAMAZOO
1415 N HARRISON ST.
KALAMAZOO, MI 49007
JAMES BAKER - CITY ENGINEER
(269) 377-8768
bakerj@kalamazoocity.org

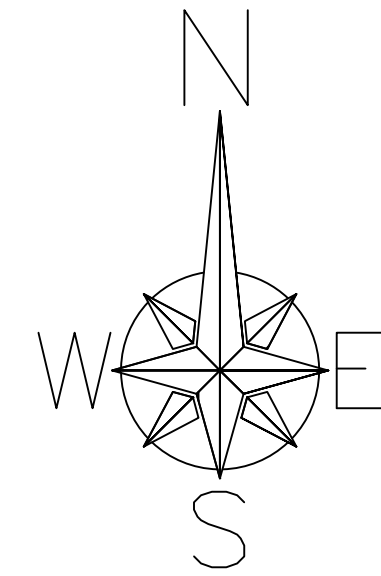
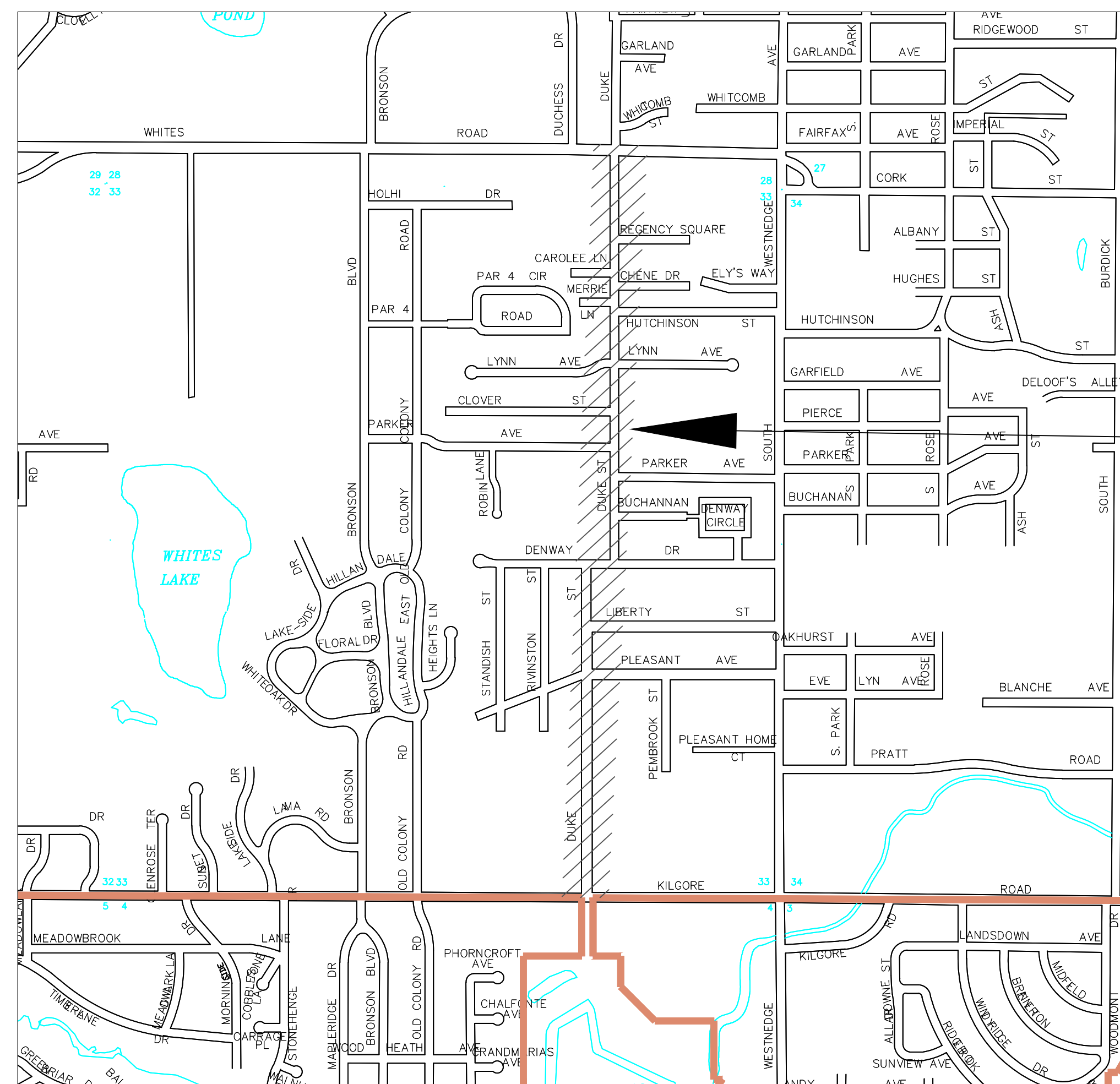

PROJECT LOCATION

City of Kalamazoo



J:\STREETS\STREET PROJECTS\LIST Projects\00354 DUKE STREET RECONSTRUCTION\Drawings\Title Log.dwg





GENERAL NOTES

DUKE ST RECONSTRUCTION PROJECT

SURVEYED	N/A	SCALE	
DESIGNED	GHW	VERTICAL	NONE
DRAWN	GHW	HORIZONTAL	NONE
QA/QC	AL	DATE	2/4/22
ENG PROJ #	TBA		

1. THE "2020 STANDARD SPECIFICATIONS FOR CONSTRUCTION" AND "STANDARD PLANS" BY THE MICHIGAN DEPARTMENT OF TRANSPORTATION (MDOT) ARE HEREBY INCORPORATED INTO THESE CONTRACT DOCUMENTS. COPIES OF THESE STANDARDS ARE AVAILABLE FOR INSPECTION AT THE OFFICE OF THE ENGINEER.
2. THE PLACING OF TRAFFIC CONTROL SIGNS AND PAVEMENT MARKINGS SHALL BE DONE IN ACCORDANCE WITH THE 2011 MICHIGAN MANUAL ON UNIFORM TRAFFIC CONTROL DEVICES (MMUTCD), AS AMENDED.
3. ALL WORK SHALL CONFORM TO ALL LOCAL, STATE AND FEDERAL LAWS, RULES AND REGULATIONS IN FORCE AT THE TIME OF CONSTRUCTION.
4. IN CONFORMANCE WITH PUBLIC ACT 174 OF 2013, ALL CONTRACTORS SHALL CALL MISS DIG @ 811 OR 800-482-7171 FOR PROTECTION OF UNDERGROUND UTILITIES A MINIMUM OF THREE FULL WORKING DAYS (EXCLUDING SATURDAYS, SUNDAYS AND HOLIDAYS) PRIOR TO BEGINNING EACH EXCAVATION IN ANY AREA. MEMBERS WILL THUS BE ROUTINELY NOTIFIED. THIS DOES NOT RELIEVE THE CONTRACTOR OF THE RESPONSIBILITY OF NOTIFYING UTILITY OWNERS WHO MAY NOT BE A PART OF THE "MISS DIG" ALERT SYSTEM. THE CONTRACTOR SHALL LOCATE ALL ACTIVE UNDERGROUND UTILITIES PRIOR TO STARTING WORK AND SHALL CONDUCT HIS OPERATIONS IN A MANNER AS TO ENSURE THAT THOSE UTILITIES NOT REQUIRING RELOCATION WILL NOT BE DISTURBED.
5. THE CONTRACTOR SHALL BE RESPONSIBLE FOR CONTACTING THE CITY OF KALAMAZOO TO NOTIFY THEM THAT WORK IS COMMENCING
6. CITY OF KALAMAZOO STANDARD DETAILS SHALL BE FOLLOWED TO THE EXTENT APPLICABLE
7. THE CONTRACTOR SHALL CONDUCT THEIR WORK IN SUCH A MANNER SO NO EXCAVATIONS ARE LEFT OPEN OVERNIGHT. IF THIS IS NOT POSSIBLE, THE CONTRACTOR SHALL PROVIDE AND INSTALL A TEMPORARY FENCE TO PROTECT THE EXCAVATION AT THEIR OWN EXPENSE.
8. TAPER THE CURBS TO ZERO HEIGHT AT SIDEWALKS. SIDEWALK RAMPS SHALL BE BARRIER FREE AND CONSTRUCTED IN ACCORDANCE WITH THE MDOT SIDEWALK RAMP AND DETECTABLE WARNING DETAILS (R-28 SERIES). SIDEWALK JOINTS SHALL BE IN ACCORDANCE WITH THE MDOT DRIVEWAY OPENINGS & APPROACHES AND CONCRETE SIDEWALKS (R-29 SERIES) UNLESS NOTED OTHERWISE.
9. ALL PERMANENT SIGNAGE SHALL COMPLY WITH THE MICHIGAN'S BARRIER FREE DESIGN REQUIREMENTS AND THE AMERICANS WITH DISABILITIES ACT.
10. ALL ELECTRICAL WORK SHALL BE PERFORMED BY A STATE OF MICHIGAN LICENSED ELECTRICIAN ACCORDING TO THE NATIONAL ELECTRICAL CODE AS MODIFIED BY THE STATE OF MICHIGAN.

FURNISH AND INSTALL ALL MATERIALS AND LABOR TO PROVIDE A COMPLETE WORKING SYSTEM.

11. THE TACTILE PLATES FOR THE ADA RAMPS WILL BE COLONIAL RED IN COLOR TO MATCH EXISTING DETECTABLE WARNING PLATES THROUGHOUT THE CITY. TRUNCATED DOMES SHALL BE TAMPED INTO WET CONCRETE IN ACCORDANCE WITH MDOT AND ADA ACCESSIBILITY GUIDELINES FOR DETECTABLE WARNINGS AND THE MANUFACTURER'S RECOMMENDATIONS FOR INSTALLATION.
12. OWNERS OF IRRIGATION SYSTEMS AND LANDSCAPING ITEMS WILL BE NOTIFIED BY THE CONTRACTOR TWO WEEKS IN ADVANCE OF ANY WORK THAT MAY AFFECT THOSE SYSTEMS. MODIFICATIONS OF THESE APPURTENANCES IS THE RESPONSIBILITY OF THE INDIVIDUAL PROPERTY OWNER AND ARE NOT A PART OF THIS CONTRACT.
13. ANY EXISTING PROPERTY CORNERS SHALL BE PRESERVED. CORNERS THAT ARE DISTURBED SHALL BE REPLACED BY A SURVEYOR LICENSED IN THE STATE OF MICHIGAN AT THE CONTRACTOR'S EXPENSE.
14. SANITARY SEWER COVERS AND CASTINGS, COVER TYPE S, WILL BE PROVIDED BY THE CITY TO THE CONTRACTOR. CONTRACTOR SHALL REQUEST DELIVERY BY CITY OF COVER TYPE S AND CASTINGS. CONTRACTOR SHOULD PLAN FOR 10 WORKINGS DAYS LEAD TIME FOR COVER AND CASTING DELIVERY FROM THE CITY.





LEGEND SHEET

DUKE ST RECONSTRUCTION PROJECT

SURVEYED	N/A	SCALE	REVISIONS
DESIGNED	GHW	VERTICAL	NONE
DRAWN	GHW	HORIZONTAL	NONE
QA/QC	AL	DATE	11/22/21
ENG PROJ #	TBA		1. QUANTITY, ILLUSTRATION, LEGEND UPDATES 01/18/23

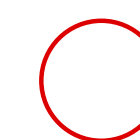
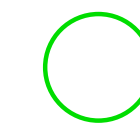
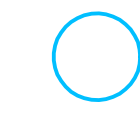
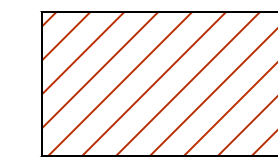
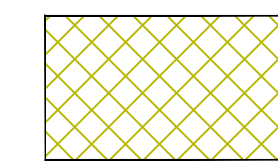
LEGEND

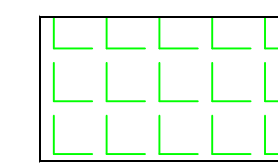
-  - SANITARY SEWER STRUCTURE
-  - STORM SEWER STRUCTURE
-  - WATER STRUCTURE
-  - 3" MILL & RESURFACING
HMA, 13A @ 165 LBS/SYD
HMA, 36A @ 165 LBS/SYD
-  - 1.5" MILL & RESURFACING
HMA, 36A @ 165 LBS/SYD
-  - CURB & GUTTER REPAIR AREAS
-  - SUBGRADE UNDERCUTTING, TYPE II

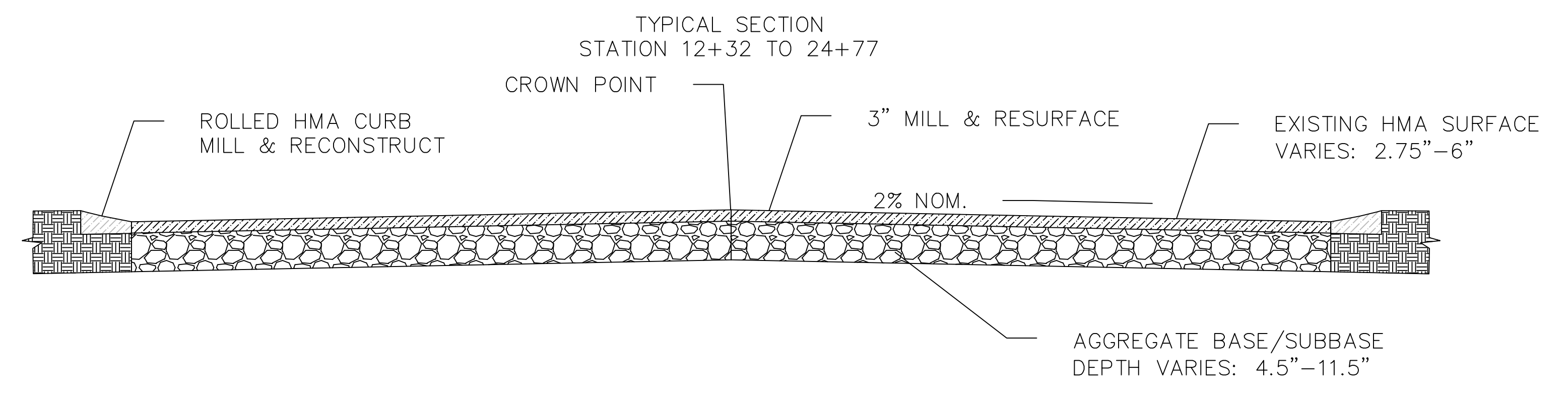
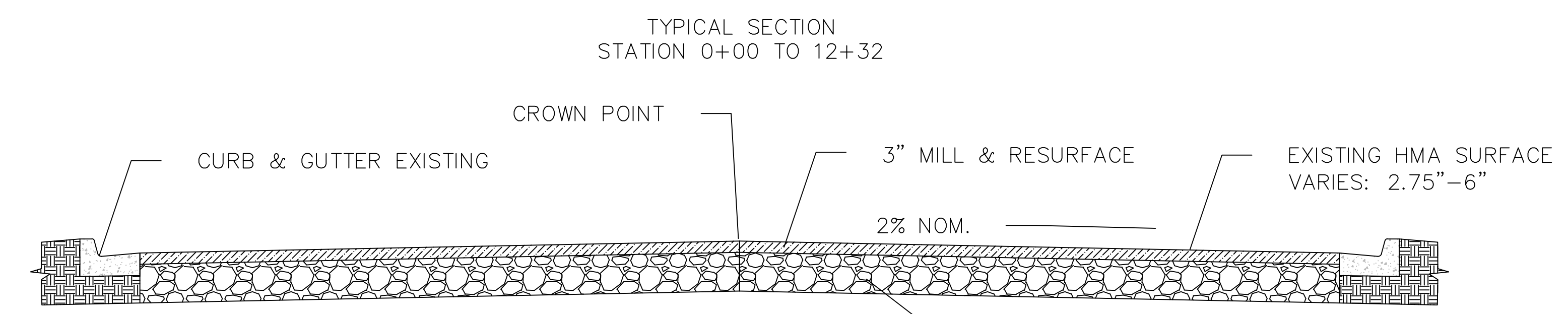

PROPOSED TYPICAL STREET LAYOUT
STATION 0+00 TO 12+32

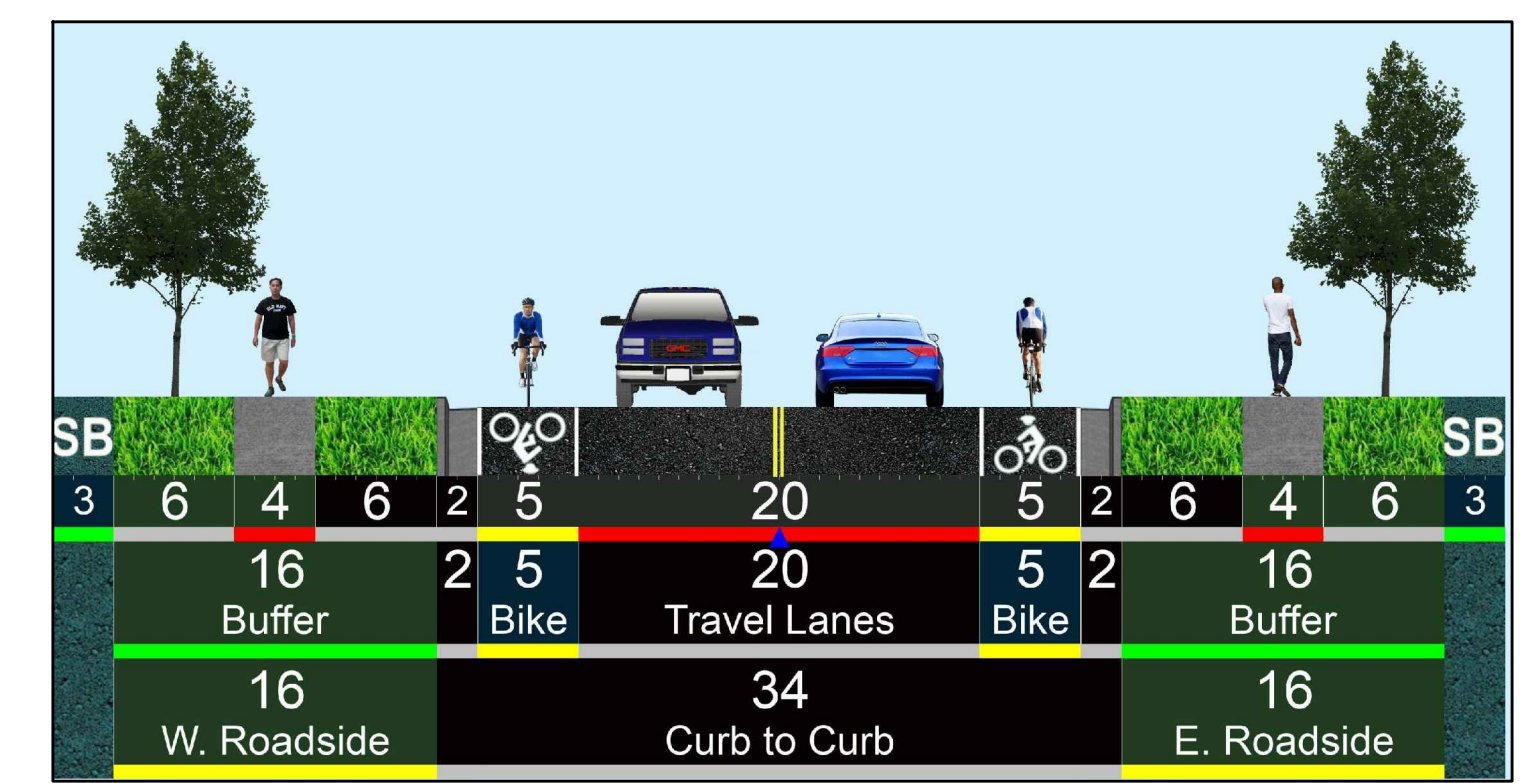

PROPOSED TYPICAL STREET LAYOUT
STATION 12+32 TO 24+77

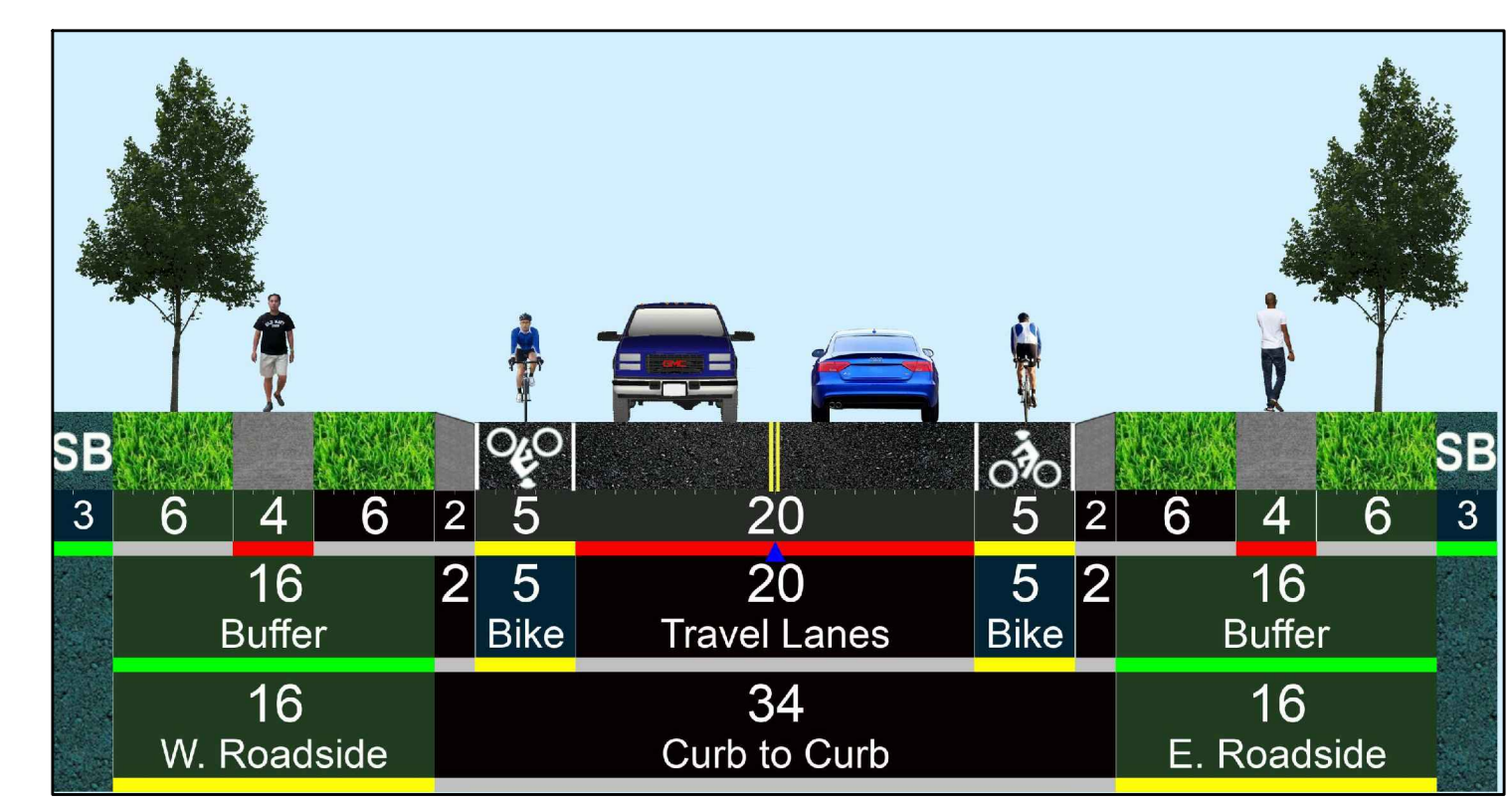

QUANTITIES THIS PROJECT

Line	PayItemCode	Description	Units	Quantity
1	1100001	Mobilization, Max 10%	LSUM	1
2	2047001	Curb and Gutter, Rem, Special	Ft	90
3	2050041	Subgrade Undercutting, Type II	Cyd	800
4	2080020	Erosion Control, Inlet Protection, Fabric Drop	Ea	18
5	4030004	Dr Structure Cover, Adj, Case 1, Modified	Ea	16
6	4030010	Dr Structure Cover, Type Q	Ea	8
7	4030050	Dr Structure Cover, Type K	Ea	2
8	5010002	Cold Milling HMA Surface, 3"	Syd	9480
9	5010002	Cold Milling HMA Surface, 1.5"	Syd	880
10	5010033	HMA, 13A	Ton	800
11	5012024	HMA, 36A	Ton	900
12	8020023	Curb and Gutter, Conc, Det C4	Ft	90
13	8110041	Pavt Mrkg, Ovly Cold Plastic, 12 inch, Crosswalk	Ft	280
17	8110045	Pavt Mrkg, Ovly Cold Plastic, 24 inch, Stop Bar	Ft	99
14	8110058	Pavt Mrkg, Ovly Cold Plastic, Bike, Small Sym	Ea	28
16	8110232	Pavt Mrkg, Waterborne, 4 inch, Yellow	Ft	11000
15	8110233	Pavt Mrkg, Waterborne, 6 inch, White	Ft	11000
18	8127051	Traffic Maintenance and Control	LSUM	1
19	8230391	Gate Box, Adj, Temp, Case 1	Ea	2
20	8230411	Gate Box, Reconst, Case 1, Modified	Ea	1
21	8230431	Gate Box, Adj, Case 1, Modified	Ea	1



		SCALE	REVISIONS
SURVEYED	N/A		
DESIGNED	GHW		
DRAWN	GHW	VERTICAL NONE	1. SUBGRADE UNDERCUTTING ADD. MINOR ADD. 01/18/23
QA/QC	AL	HORIZONTAL N/A	
ENG PROJ #	TBA	DATE 11/22/21	





SURVEYED	N/A	SCALE	REVISIONS
DESIGNED	GHW	VERTICAL	NONE
DRAWN	GHW	HORIZONTAL	N/A
QA/QC	AL	DATE	11/22/21
ENG PROJ #	TBA		1. SUBGRADE UNDERCUTTING ADD, MINOR ADD 01/18/23





SURVEYED	N/A	SCALE	REVISIONS
DESIGNED	GHW	VERTICAL	NONE
DRAWN	GHW	HORIZONTAL	N/A
QA/QC	AL	DATE	11/22/21
ENG PROJ #	TBA		1. SUBGRADE UNDERCUTTING ADD, MINOR ADD 01/18/23

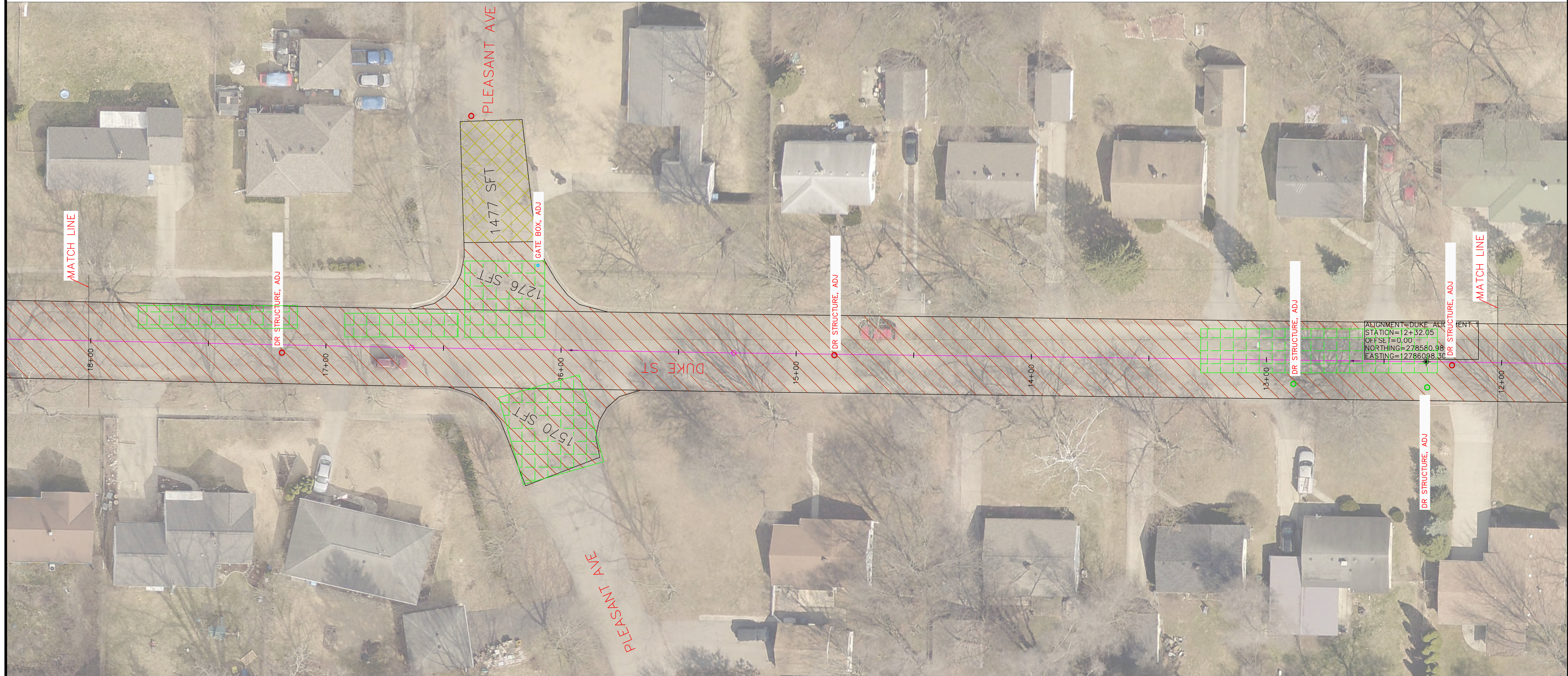



DESIGN INFORMATION		SCALE	REVISIONS
SURVEYED	N/A		
DESIGNED	GHW		
DRAWN	GHW	VERTICAL	NONE
QA/QC	AL	HORIZONTAL	N/A
ENG. PROJ. #	TBA	DATE	11/22/21
			1. SUBGRADE UNDERCUTTING ADD, MINOR ADD 01/18/23





SURVEYED	N/A	SCALE	REVISIONS
DESIGNED	GHW	VERTICAL	NONE
DRAWN	GHW	HORIZONTAL	N/A
QA/QC	AL	DATE	11/22/21
ENG PROJ #	TBA		1. SUBGRADE UNDERCUTTING ADD, MINOR ADD 01/18/23

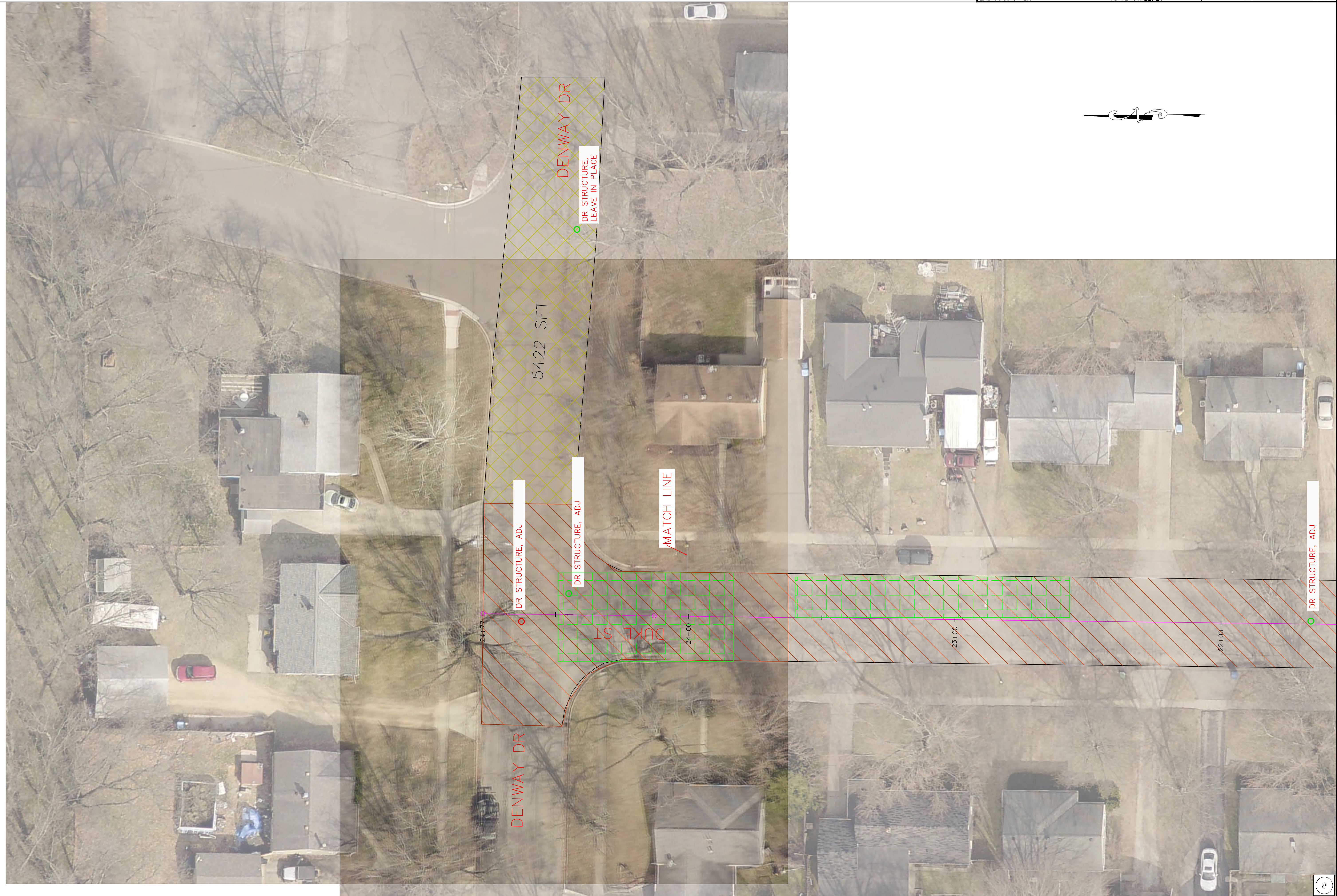
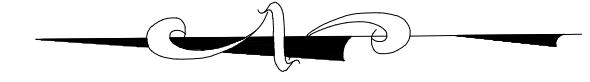



		SCALE	REVISIONS
SURVEYED	N/A		
DESIGNED	GHW		
DRAWN	GHW	VERTICAL NONE	1. SUBGRADE UNDERCUTTING ADD. MINOR ADD 01/18/23
QA/QC	AL	HORIZONTAL N/A	
ENG PROJ #	TBA	DATE 11/22/21	

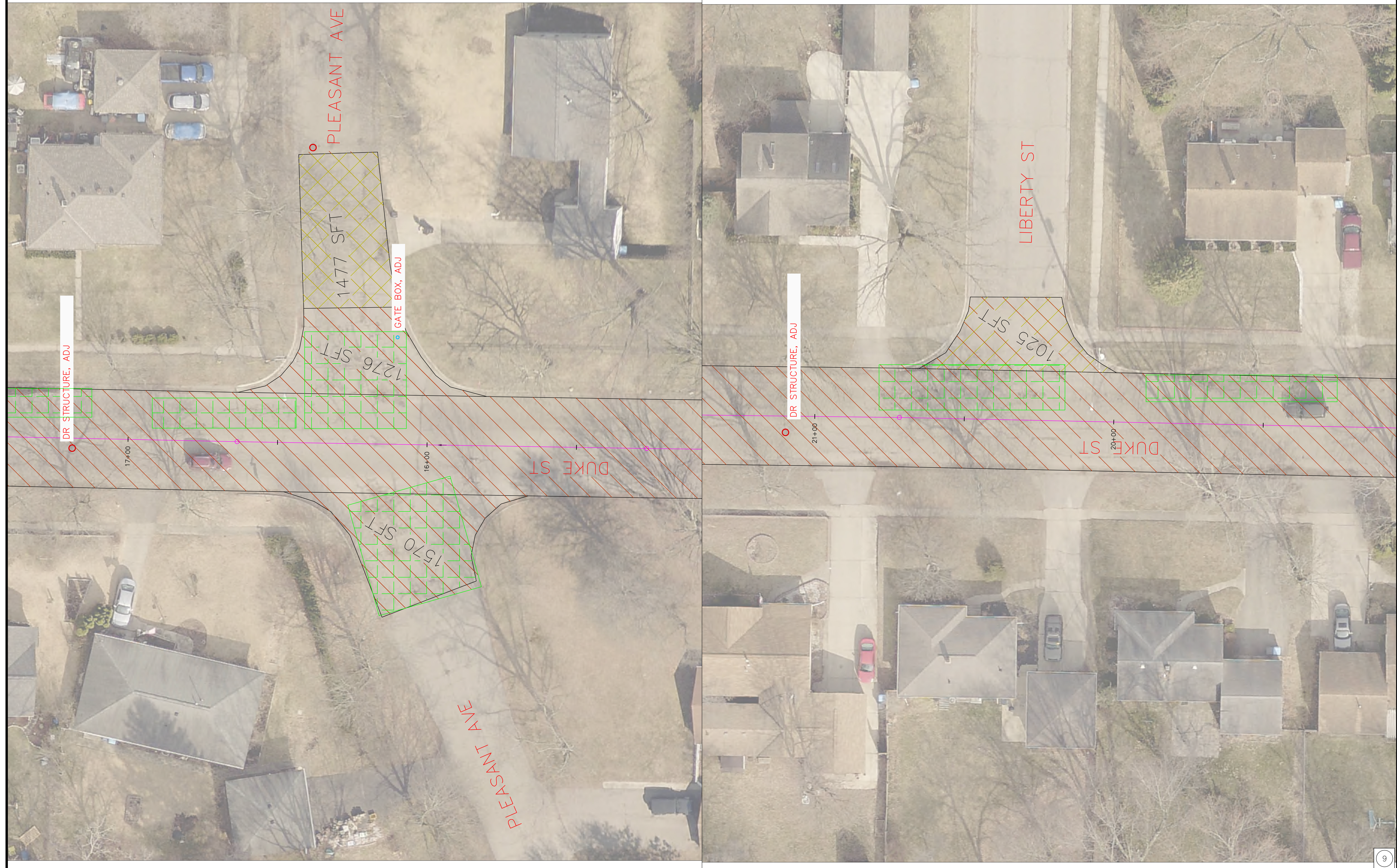
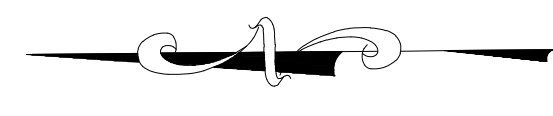



PAVEMENT MARKINGS

DUKE ST RECONSTRUCTION PROJECT

		SCALE	REVISIONS
SURVEYED	N/A		
DESIGNED	GHW		
DRAWN	GHW	VERTICAL NONE	1. PAVEMENT MARKING UPDATES 01/18/23
QA/QC	AL	HORIZONTAL N/A	
ENG PROJ #	TBA	DATE 11/22/21	

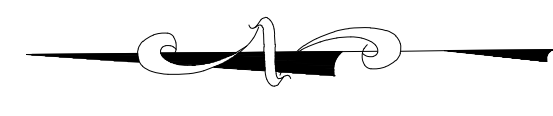



PAVEMENT MARKINGS
DUKE ST RECONSTRUCTION PROJECT

		SCALE	REVISIONS
SURVEYED	N/A		
DESIGNED	GHW		
DRAWN	GHW	VERTICAL NONE	1. PAVEMENT MARKING UPDATES 01/18/23
QA/QC	AL	HORIZONTAL N/A	
ENG PROJ #	TBA	DATE 11/22/21	

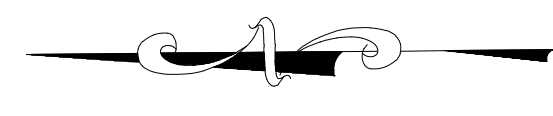



PAVEMENT MARKINGS

DUKE ST RECONSTRUCTION PROJECT

		SCALE	REVISIONS
SURVEYED	N/A		
DESIGNED	GHW		
DRAWN	GHW	VERTICAL	NONE
QA/QC	AL	HORIZONTAL	N/A
ENG PROJ #	TBA	DATE	11/22/21
			1. PAVEMENT MARKING UPDATES 01/18/23

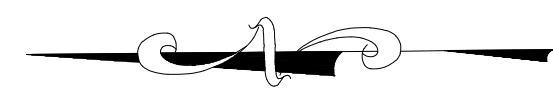

6 INCH, WHITE

BUCHANAN AVE

PARKER AVE

MATCH LINE

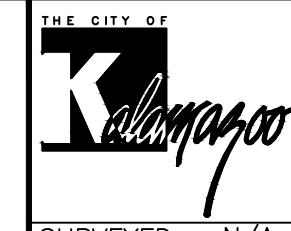

PAVEMENT MARKINGS

DUKE ST RECONSTRUCTION PROJECT

SURVEYED	N/A	SCALE	REVISIONS
DESIGNED	GHW	VERTICAL	NONE
DRAWN	GHW	HORIZONTAL	N/A
QA/QC	AL	DATE	11/22/21
ENG. PROJ. #	TBA		1. PAVEMENT MARKING UPDATES 01/18/23





PAVEMENT MARKINGS

DUKE ST RECONSTRUCTION PROJECT

SURVEYED	N/A	SCALE	REVISIONS
DESIGNED	GHW	VERTICAL	NONE
DRAWN	GHW	HORIZONTAL	N/A
QA/QC	AL	DATE	11/22/21
ENG PROJ #	TBA		1. PAVEMENT MARKING UPDATES 01/18/23

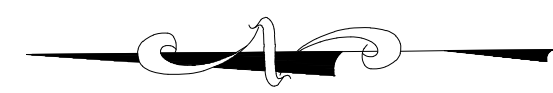





PAVEMENT MARKINGS

DUKE ST RECONSTRUCTION PROJECT

SURVEYED	N/A	SCALE	REVISIONS
DESIGNED	GHW	VERTICAL	NONE
DRAWN	GHW	HORIZONTAL	N/A
QA/QC	AL	DATE	11/22/21
ENG PROJ #	TBA		1. PAVEMENT MARKING UPDATES 01/18/23

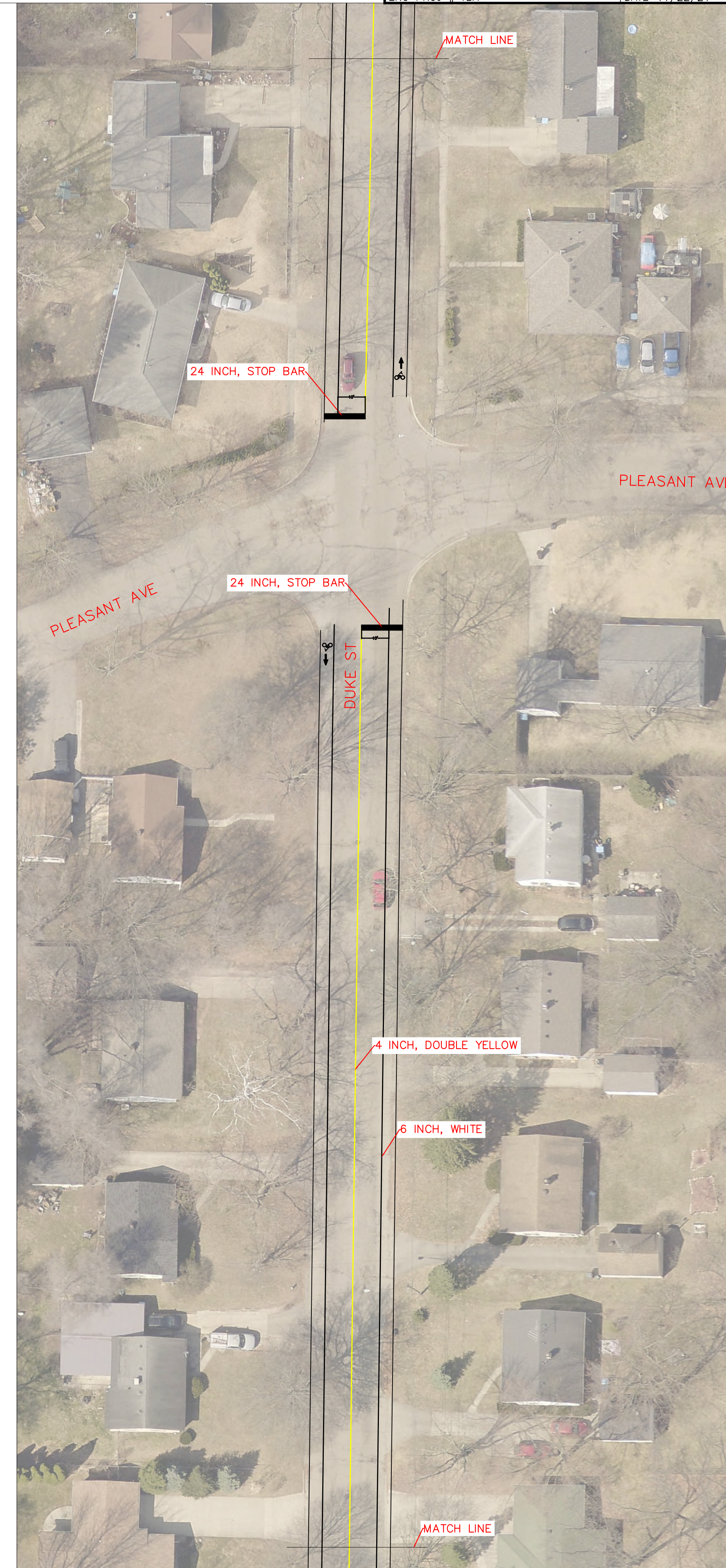



PAVEMENT MARKINGS

DUKE ST RECONSTRUCTION PROJECT

DESIGNED		SCALE	REVISIONS
SURVEYED	N/A	VERTICAL NONE	1. PAVEMENT MARKING UPDATES 01/18/23
DRAWN	GHW		
QA/QC	AL	HORIZONTAL N/A	
ENG PROJ #	TBA	DATE 11/22/21	







PAVEMENT MARKINGS

DUKE ST RECONSTRUCTION PROJECT

SURVEYED		SCALE		REVISIONS	
N/A					
DESIGNED	GHW	VERTICAL	NONE	1. PAVEMENT MARKING UPDATES 01/18/23	
DRAWN	GHW	HORIZONTAL	N/A		
QA/QC	AL	DATE	11/22/21		
ENG. PROJ. #	TBA				





PAVEMENT MARKINGS

DUKE ST RECONSTRUCTION PROJECT

		SCALE	REVISIONS
SURVEYED	N/A		
DESIGNED	GHW		
DRAWN	GHW	VERTICAL NONE	1. PAVEMENT MARKING UPDATES 01/18/23
QA/QC	AL	HORIZONTAL N/A	
ENG. PROJ. #	TBA	DATE 11/22/21	



STANDARD DETAIL – SIDEWALK
ROOT AVOIDANCE – MEANDERING SIDEWALK

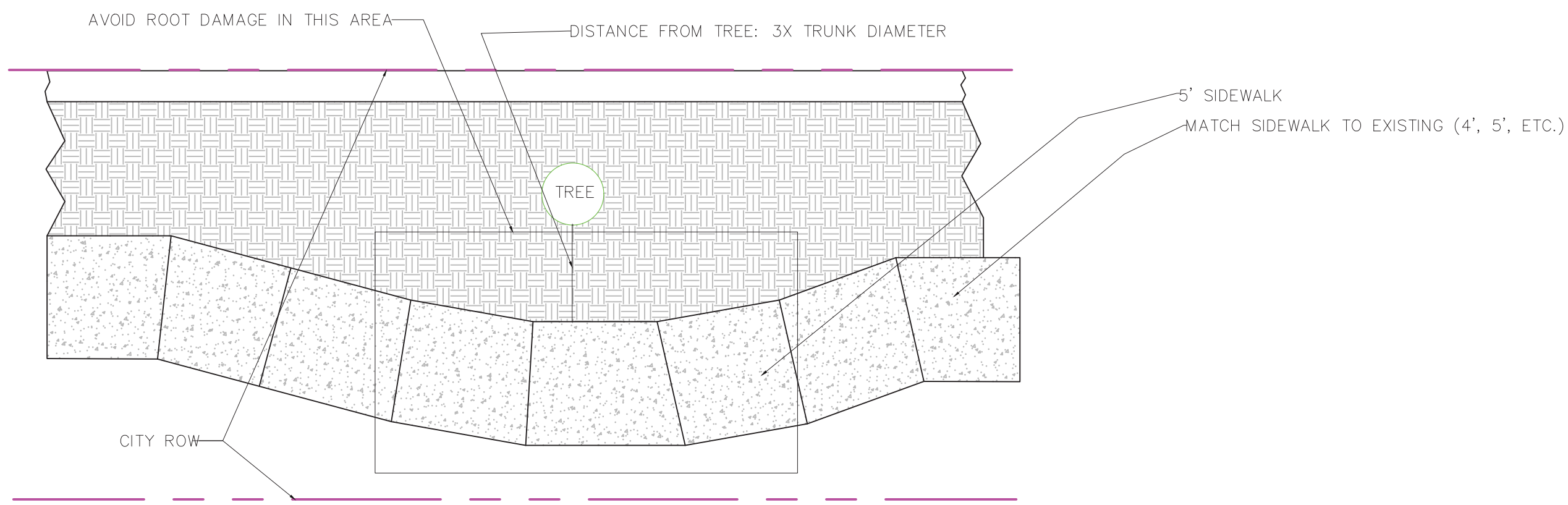

STANDARD DETAIL – SIDEWALK
ROOT AVOIDANCE

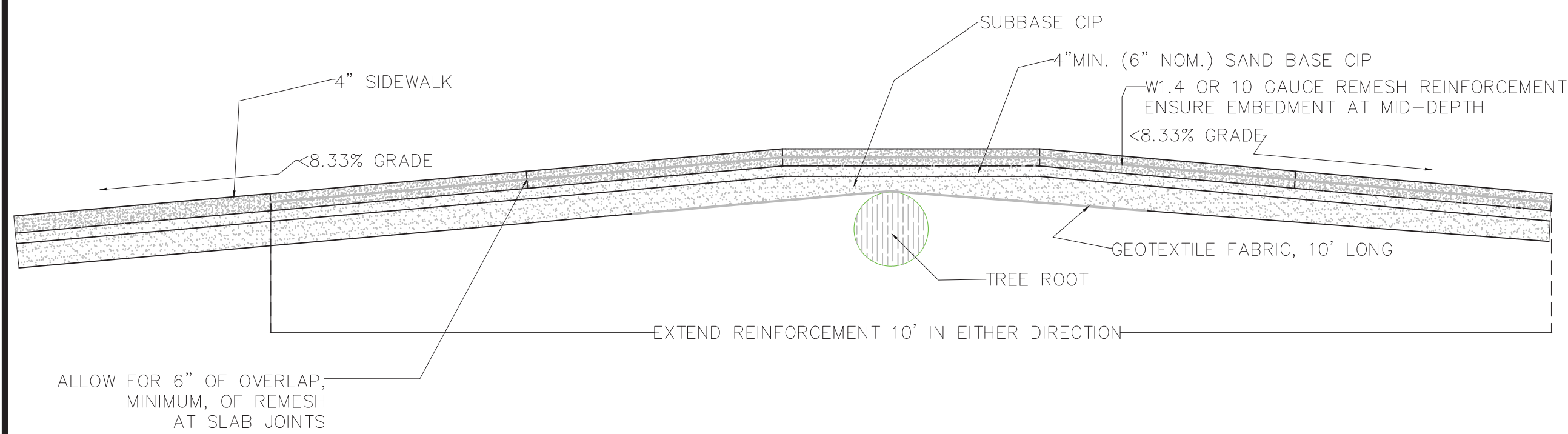

STANDARD DETAIL – SIDEWALK
ROOT AVOIDANCE – W/O REINFORCEMENT
(USE ONLY AS DIRECTED BY ENGINEER)

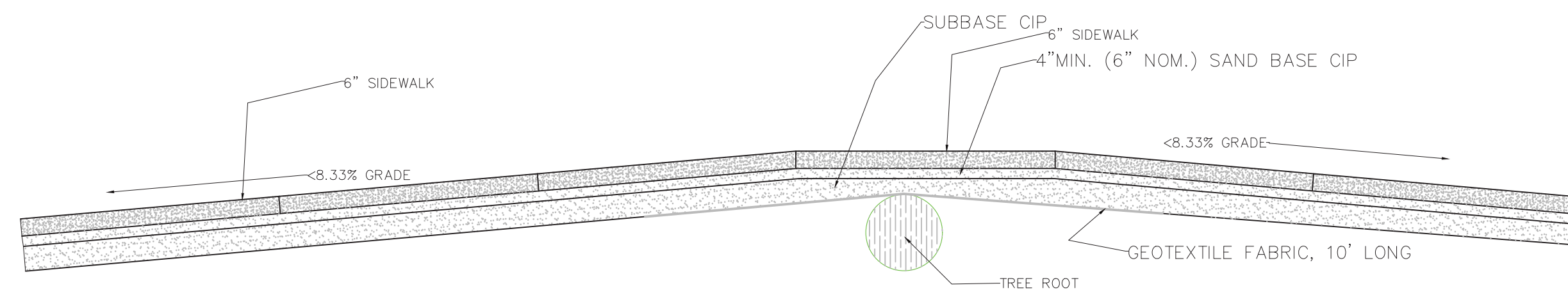

TYPICAL 4" SIDEWALK DETAIL

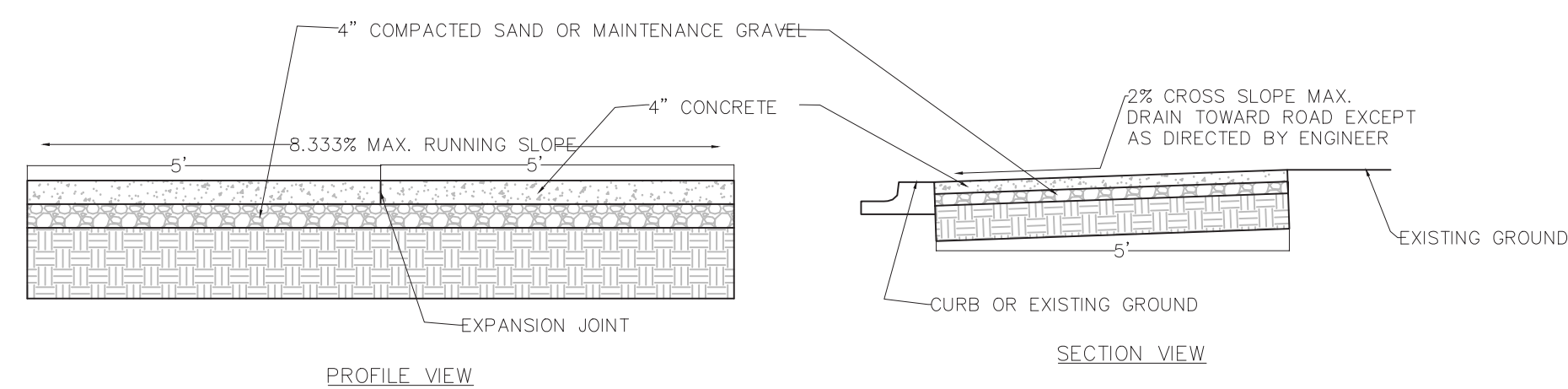

ROOT CRACKING OF SIDEWALK

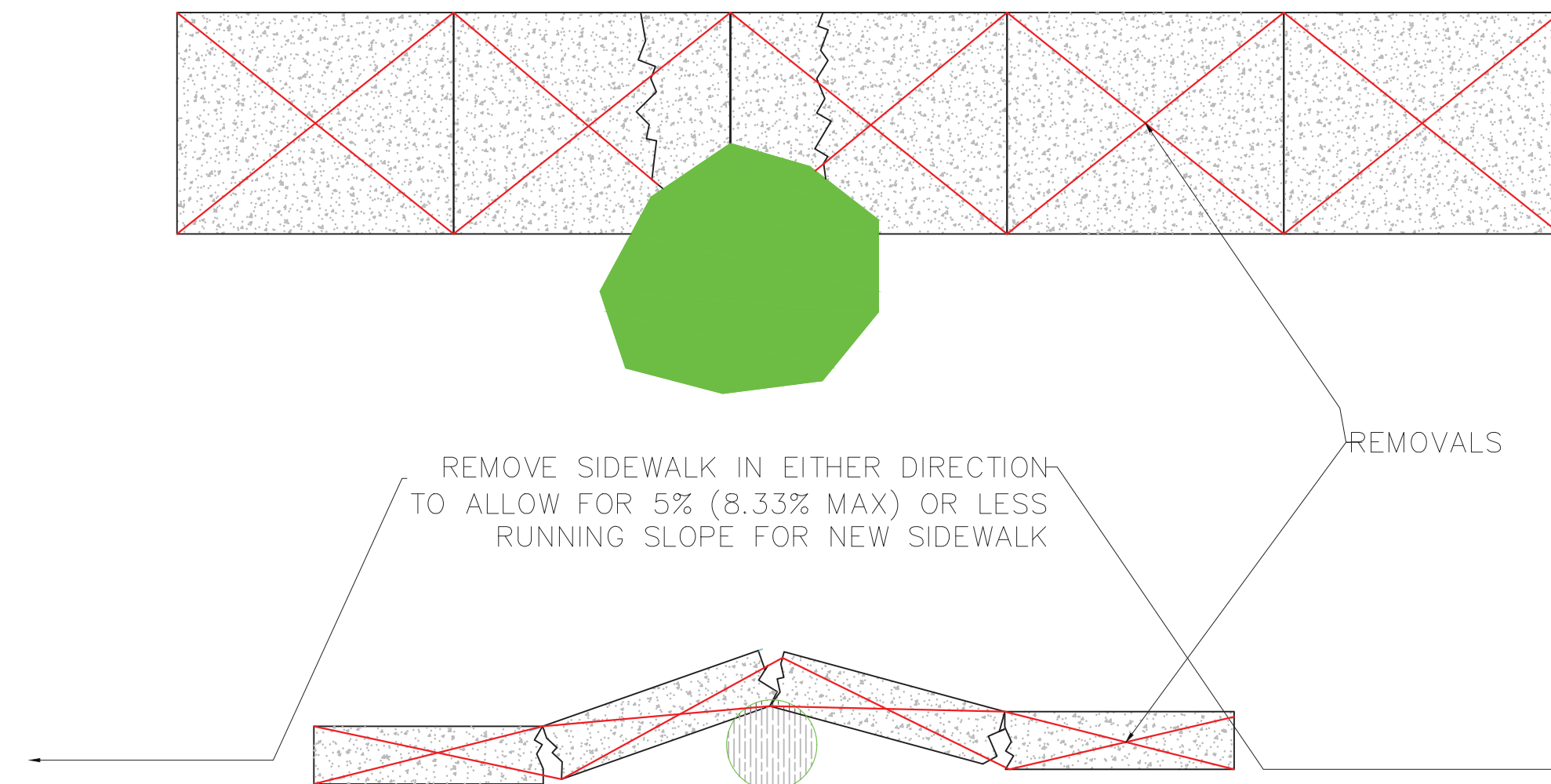

STANDARD DETAIL – WEDGING
A CUT/MILLED SECTION

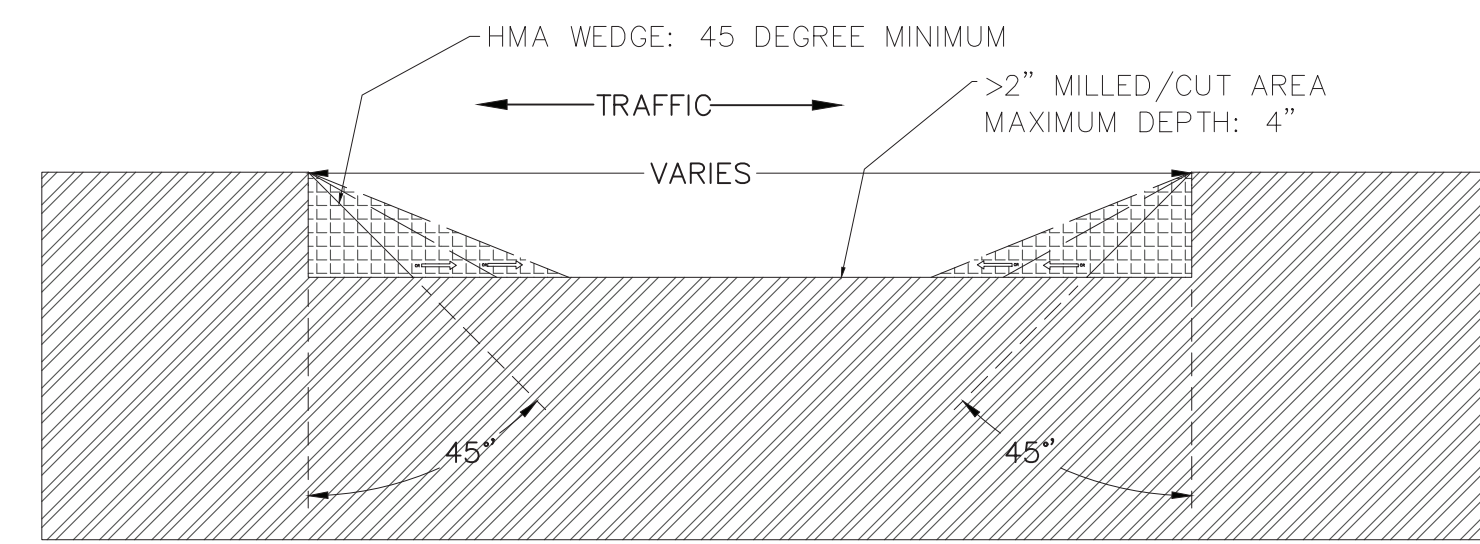

STANDARD DETAIL – LOW VOLUME/RESIDENTIAL ROADS
PERFORATED PIPE DETAIL

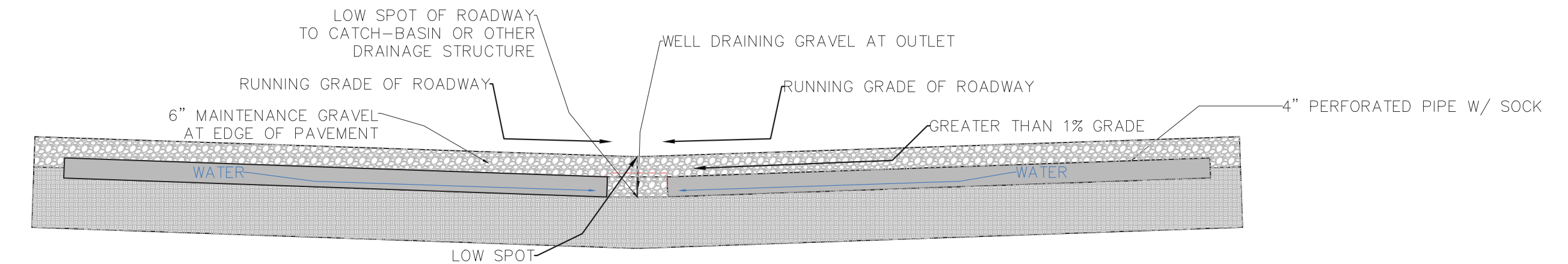

STANDARD DETAIL – LOW VOLUME/RESIDENTIAL ROADS
POORLY DRAINED AREAS

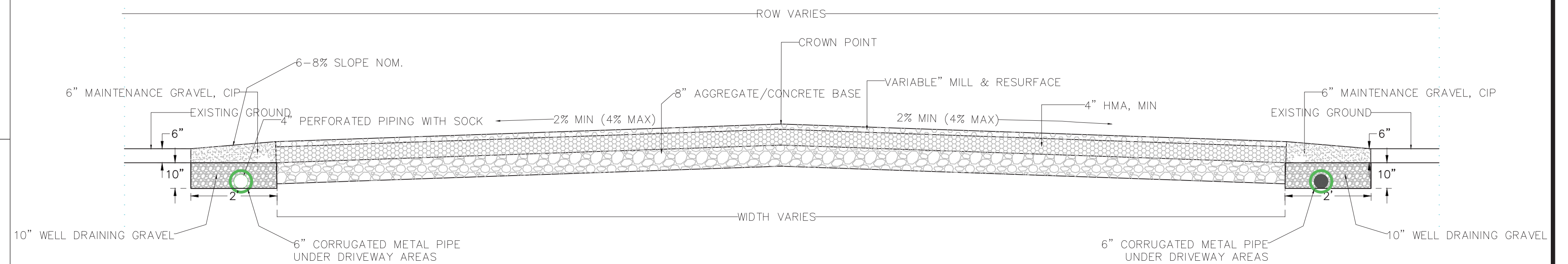

STANDARD DETAIL – LOW VOLUME/RESIDENTIAL ROADS
EASILY DRAINED AREAS

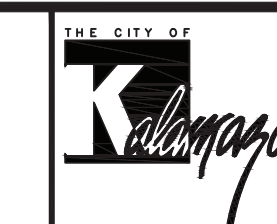
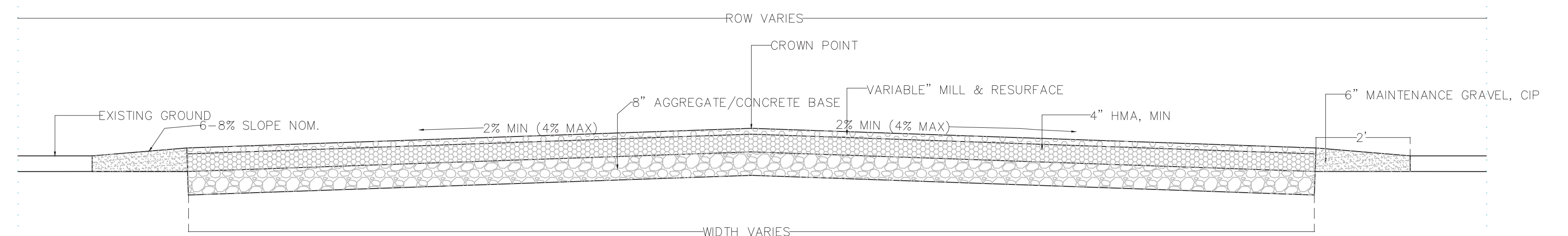

SURVEYED	N/A	SCALE	REVISIONS
DESIGNED	GHW	VERTICAL NOT TO SCALE	1, 12.18.20 - Agg base depth & option of 2C base
DRAWN	GHW	HORIZONTAL NOT TO SCALE	1, 12.17.21 - General updates plus MDOT HMA updates
QA/QC	AL	DATE	11/23/2020
ENG PROJ #	XXX-XX		

GENERAL NOTES:

- MDOT STANDARD PLANS R-28-J, R-29-I, R-30-G, AND R-44-F SHALL BE FOLLOWED IN CONJUNCTION WITH THESE STANDARD PLANS
- ALL SAW CUTTING SHALL BE DONE PERPENDICULAR AND PARALLEL TO THE DIRECTION OF TRAVEL
- SAW CUTTING SHALL PROVIDE A STRAIGHT, CLEAN, EDGE TO ENHANCE BONDING
- ALL CUTS SHALL BE RECTANGULAR AND NEATLY CUT TO AVOID SPALLING OF PAVEMENT
- IN GENERAL ALL ROAD/UTILITY CUTS OF AN AREA GREATER THAN 25SFT (5FTX5FT TYPICAL) SHALL EXTEND THE FULL WIDTH OF THE TRAVEL LANE
- FOR PAVEMENT WITH LOAD TRANSFER DOWEL RODS OR REINFORCEMENT: NEW LOAD TRANSFER DOWELS/REINFORCEMENT SHALL BE PLACED TO MAINTAIN BEARING CAPACITY OF ROADWAY
- CUTS LESS THAN 12" SHALL BE PATCHED WITH PCC. IF GREATER THAN 12", ENSURE CUT IS IN ACCORDANCE WITH STANDARD DETAILS AND MATCHING EXISTING ROADWAY
- BUMPS/CUTS/MILLED AREAS WITH EDGE GREATER THAN 2" DEEP/HIGH MUST BE WEDGED WITH HMA BEFORE OPEN TO TRAFFIC. SEE STANDARD DETAIL.
- MEANDERING SIDEWALK SHALL ONLY BE PLACED IN THE CITY'S ROW OR WHERE AN EASEMENT IS ESTABLISHED
- NEW SIDEWALK CONSTRUCTION SHALL MEET OR EXCEED CURRENT ADA AND ACCESSIBILITY STANDARDS
- REPLACED SIDEWALK SHALL, TO THE EXTENT PRACTICABLE, MEET OR EXCEED ADA AND ACCESSIBILITY STANDARDS
- SIDEWALK, DRIVEWAY OPENINGS & APPROACHES SHALL CONFORM TO MDOT STANDARD PLAN DETAILS R-28-J AND R-29-I
- MARSHALL MIX 13A (BASE/LEVELING) MAY BE SUBSTITUTED FOR SUPERPAVE HMA BASE MIX DESIGNS WITH CITY OF KALAMAZOO APPROVAL IF DEEMED APPROPRIATE BY THE ENGINEER
- ASPHALT BINDER SHALL BE INCLUDED IN THE PAY ITEM FOR HMA
- MDOT PCC P1 MIX DESIGN SHALL BE USED FOR ALL CONCRETE UNLESS OTHERWISE STATED OR DIRECTED BY THE ENGINEER
- OPENING TO TRAFFIC STRENGTHS (2012 STANDARD SPECIFICATIONS FOR CONSTRUCTION, TABLE 603-1):
 - <72 HOURS, GRADE P-NC, 300 psi
 - 72 HOURS +, GRADE P1, P1M, 550 psi



STANDARD DETAILS

CITY OF KALAMAZOO

SURVEYED		SCALE		REVISIONS	
DESIGNED	N/A	VERTICAL	NOT TO SCALE	1. 12.18.20	Agg base depth & option of 2C base
DRAWN	GHW	HORIZONTAL	NOT TO SCALE	2. 12.17.21	General updates plus MDOT HMA updates
QA/QC	AL	DATE	11/23/2020		
ENG PROJ #	XXX-XX				

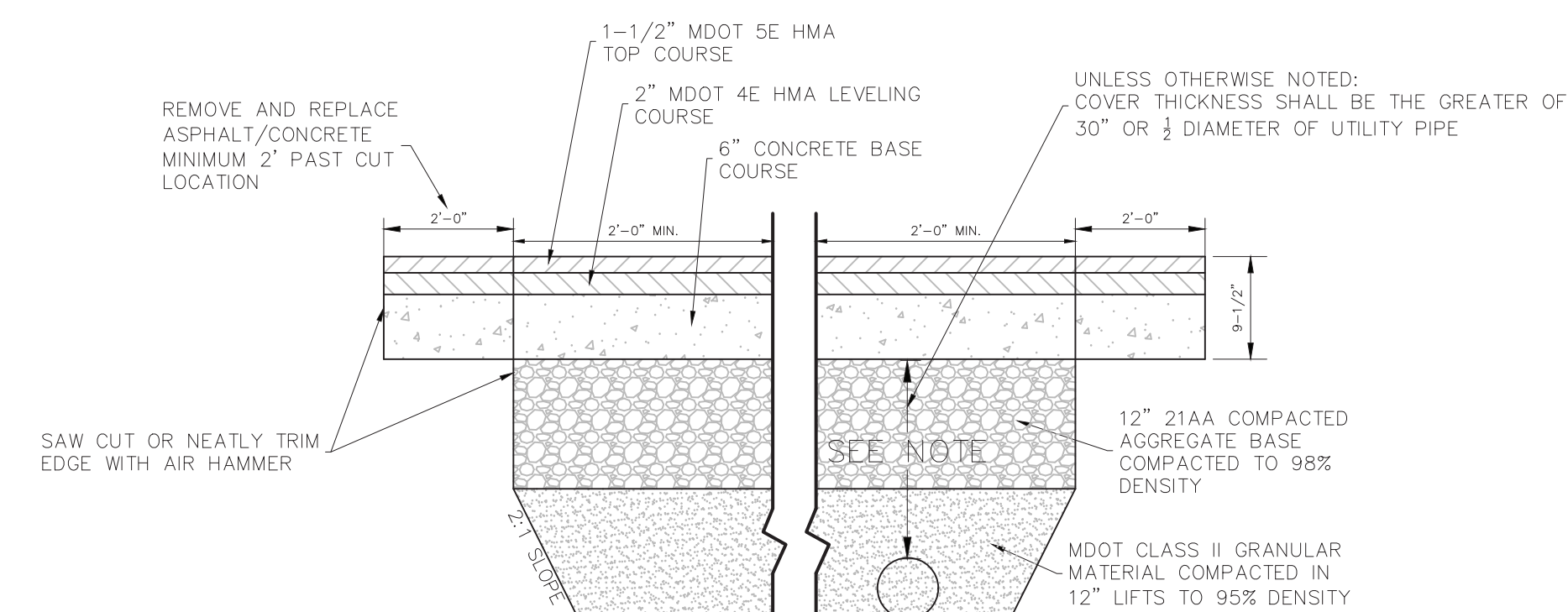

ASPHALT WITH CONCRETE BASE TRENCH DETAIL

- NOTE:
- CUT SHALL BE PARALLEL OR PERPENDICULAR TO EDGE OF ROADWAY/GUTTER
 - FOR POTHoles 12" DIAMETER AND SMALLER - ALL CONCRETE
 - FOR 1' x 1' AND LARGER HAND COMPACT LAYERS AS SHOWN AND FINISH WITH CONCRETE

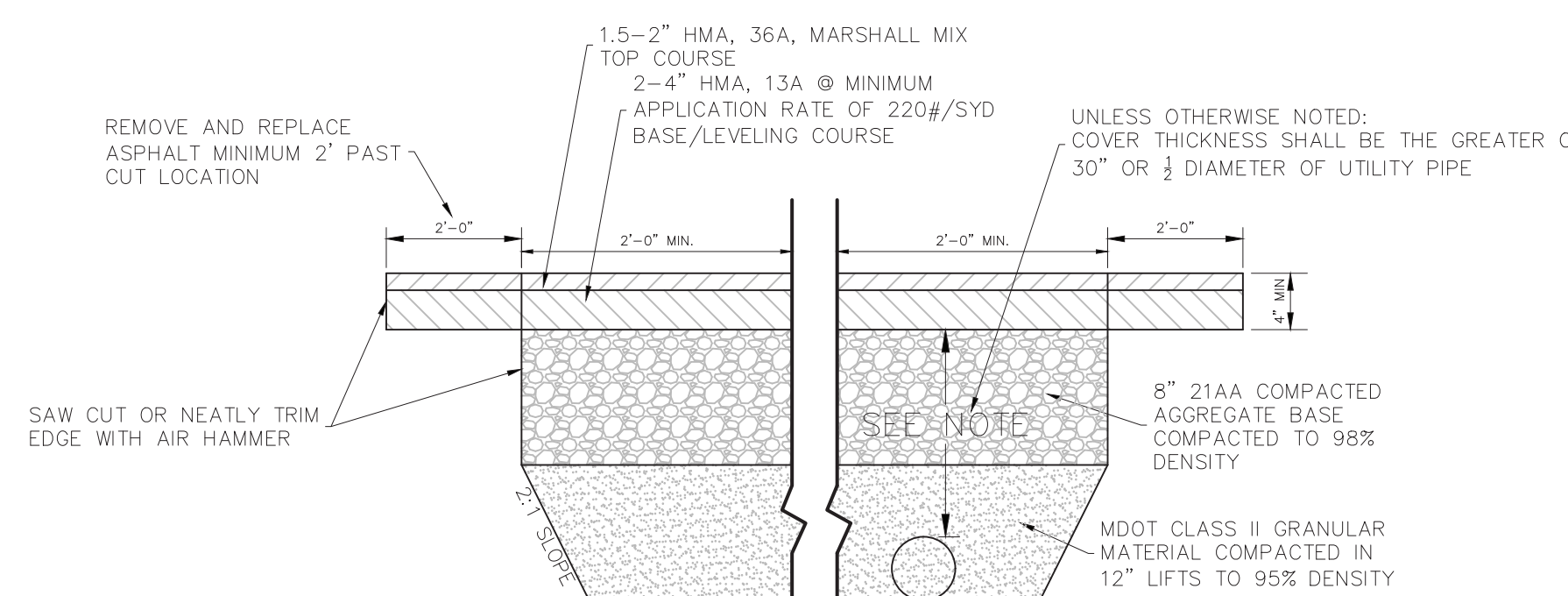

RESIDENTAL / LOW TRAFFIC VOLUME ROAD ASPHALT UTILITY TRENCH DETAIL

- NOTE:
- CUT SHALL BE PARALLEL OR PERPENDICULAR TO EDGE OF ROADWAY/GUTTER
 - *SS-1H @ 0.10/GAL/SYD BETWEEN LIFTS
 - PERFORMANCE GRADE BINDER TO BE USED: PG 64-28

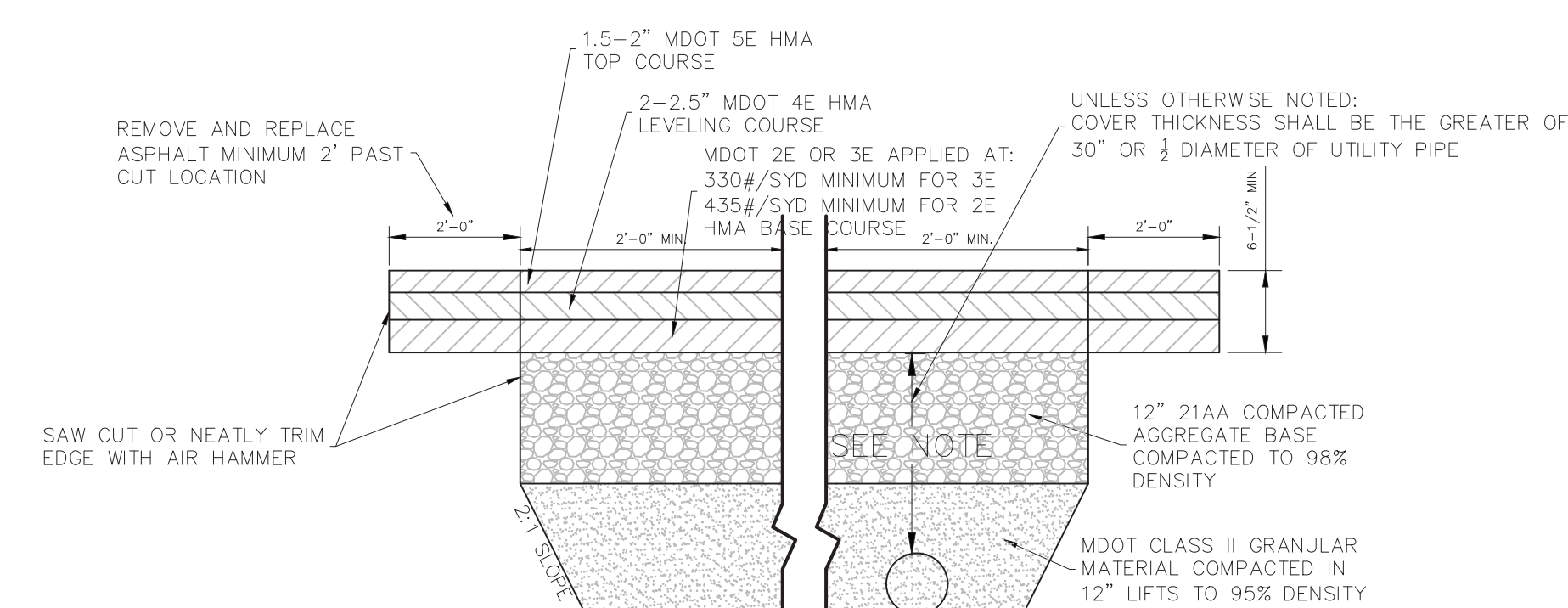

COMMERCIAL ROAD ASPHALT UTILITY TRENCH DETAIL

- NOTE:
- CUT SHALL BE PARALLEL OR PERPENDICULAR TO EDGE OF ROADWAY/GUTTER
 - *SS-1H @ 0.10/GAL/SYD BETWEEN LIFTS
 - PERFORMANCE GRADE BINDER TO BE USED: PG 64-28
 - HEAVY COMMERCIAL ADT COULD WARRANT CHANGE TO DESIGN.

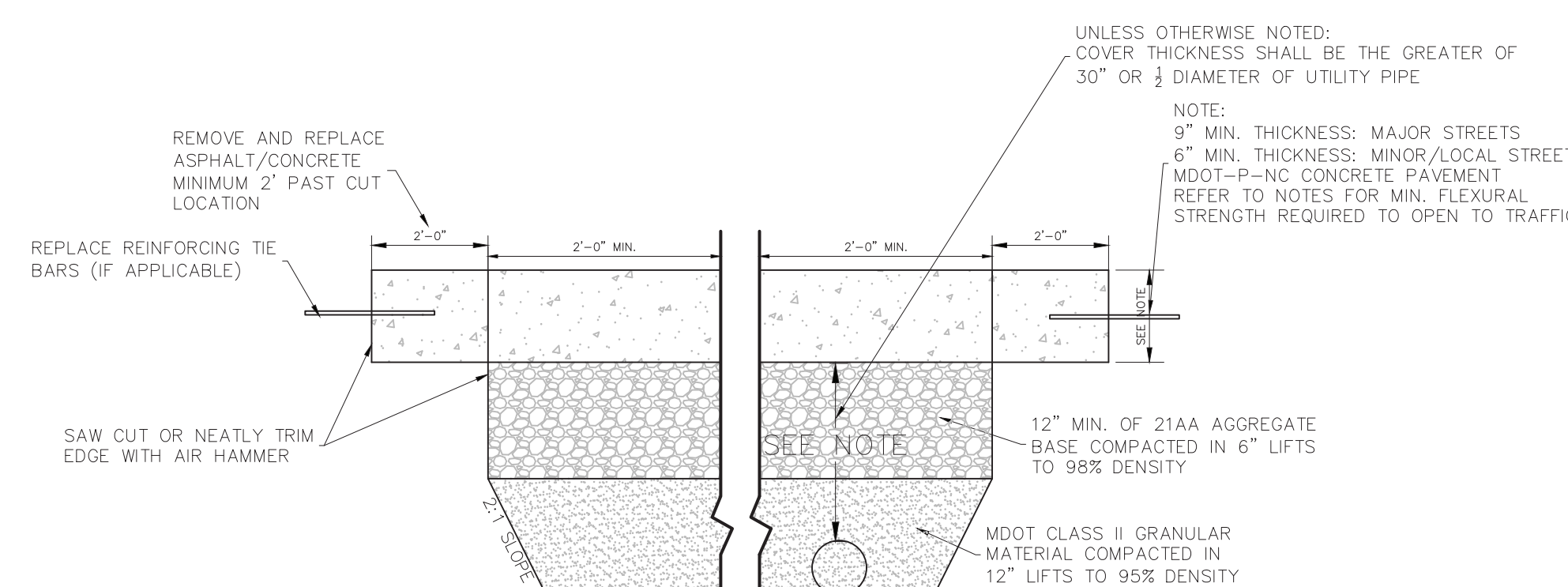

TYPICAL CUT USING PCC TO FILL (WINTER CUT)

- NOTE:
- CUT SHALL BE PARALLEL OR PERPENDICULAR TO EDGE OF ROADWAY/GUTTER
 - FOR POTHoles 12" DIAMETER AND SMALLER - ALL CONCRETE
 - FOR 1' x 1' AND LARGER HAND COMPACT LAYERS AS SHOWN AND FINISH WITH CONCRETE

GENERAL NOTES:

- MDOT STANDARD PLANS R-28-J, R-29-I, R-30-G, AND R-44-F SHALL BE FOLLOWED IN CONJUNCTION WITH THESE STANDARD PLANS
- ALL SAW CUTTING SHALL BE DONE PERPENDICULAR AND PARALLEL TO THE DIRECTION OF TRAVEL
- SAW CUTTING SHALL PROVIDE A STRAIGHT, CLEAN, EDGE TO ENHANCE BONDING
- ALL CUTS SHALL BE RECTANGULAR AND NEATLY CUT TO AVOID SPALLING OF PAVEMENT
- IN GENERAL ALL ROAD/UTILITY CUTS OF AN AREA GREATER THAN 25SFT (5FTX5FT TYPICAL) SHALL EXTEND THE FULL WIDTH OF THE TRAVEL LANE
- FOR PAVEMENT WITH LOAD TRANSFER DOWEL RODS OR REINFORCEMENT: NEW LOAD TRANSFER DOWELS/REINFORCEMENT SHALL BE PLACED TO MAINTAIN BEARING CAPACITY OF ROADWAY
- CUTS LESS THAN 12" SHALL BE PATCHED WITH PCC. IF GREATER THAN 12", ENSURE CUT IS IN ACCORDANCE WITH STANDARD DETAILS AND MATCHING EXISTING ROADWAY
- BUMPS/CUTS/MILLED AREAS WITH EDGE GREATER THAN 2" DEEP/HIGH MUST BE WEDGED WITH HMA BEFORE OPEN TO TRAFFIC. SEE STANDARD DETAIL.
- MEANDERING SIDEWALK SHALL ONLY BE PLACED IN THE CITY'S ROW OR WHERE AN EASEMENT IS ESTABLISHED
- NEW SIDEWALK CONSTRUCTION SHALL MEET OR EXCEED CURRENT ADA AND ACCESSIBILITY STANDARDS
- REPLACED SIDEWALK SHALL, TO THE EXTENT PRACTICABLE, MEET OR EXCEED ADA AND ACCESSIBILITY STANDARDS
- SIDEWALK, DRIVEWAY OPENINGS & APPROACHES SHALL CONFORM TO MDOT STANDARD PLAN DETAILS R-28-J AND R-29-I
- MARSHALL MIX 13A (BASE/LEVELING) MAY BE SUBSTITUTED FOR SUPERPAVE HMA BASE MIX DESIGNS WITH CITY OF KALAMAZOO APPROVAL IF DEEMED APPROPRIATE BY THE ENGINEER
- ASPHALT BINDER SHALL BE INCLUDED IN THE PAY ITEM FOR HMA
- MDOT PCC P1 MIX DESIGN SHALL BE USED FOR ALL CONCRETE UNLESS OTHERWISE STATED OR DIRECTED BY THE ENGINEER
- OPENING TO TRAFFIC STRENGTHS (2012 STANDARD SPECIFICATIONS FOR CONSTRUCTION, TABLE 603-1):
 - <72 HOURS, GRADE P-NC, 300 psi
 - 72 HOURS +, GRADE P1, P1M, 550 psi

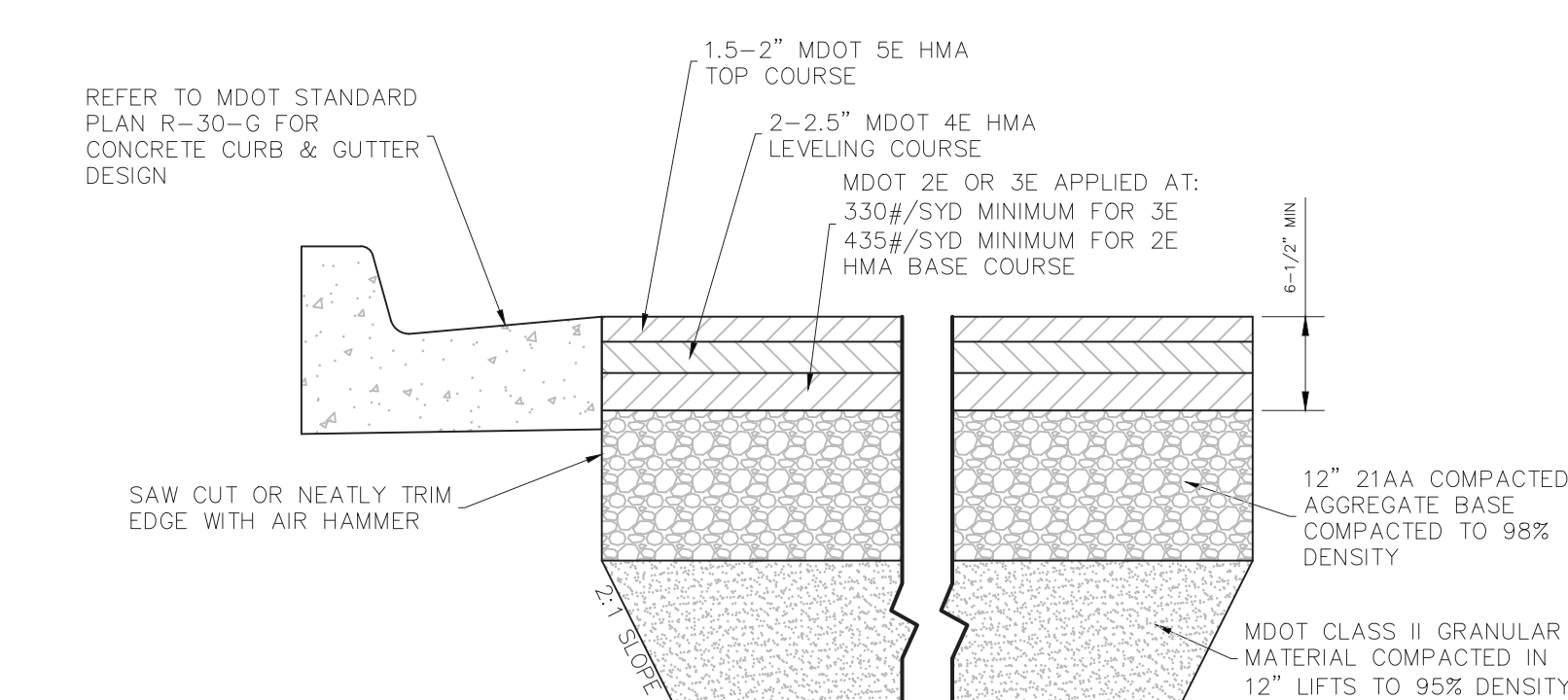

COMMERCIAL ROAD ASPHALT PAVEMENT DETAIL

- NOTE:
- *SS-1H @ 0.10/GAL/SYD BETWEEN LIFTS
 - PERFORMANCE GRADE BINDER TO BE USED: PG 64-28

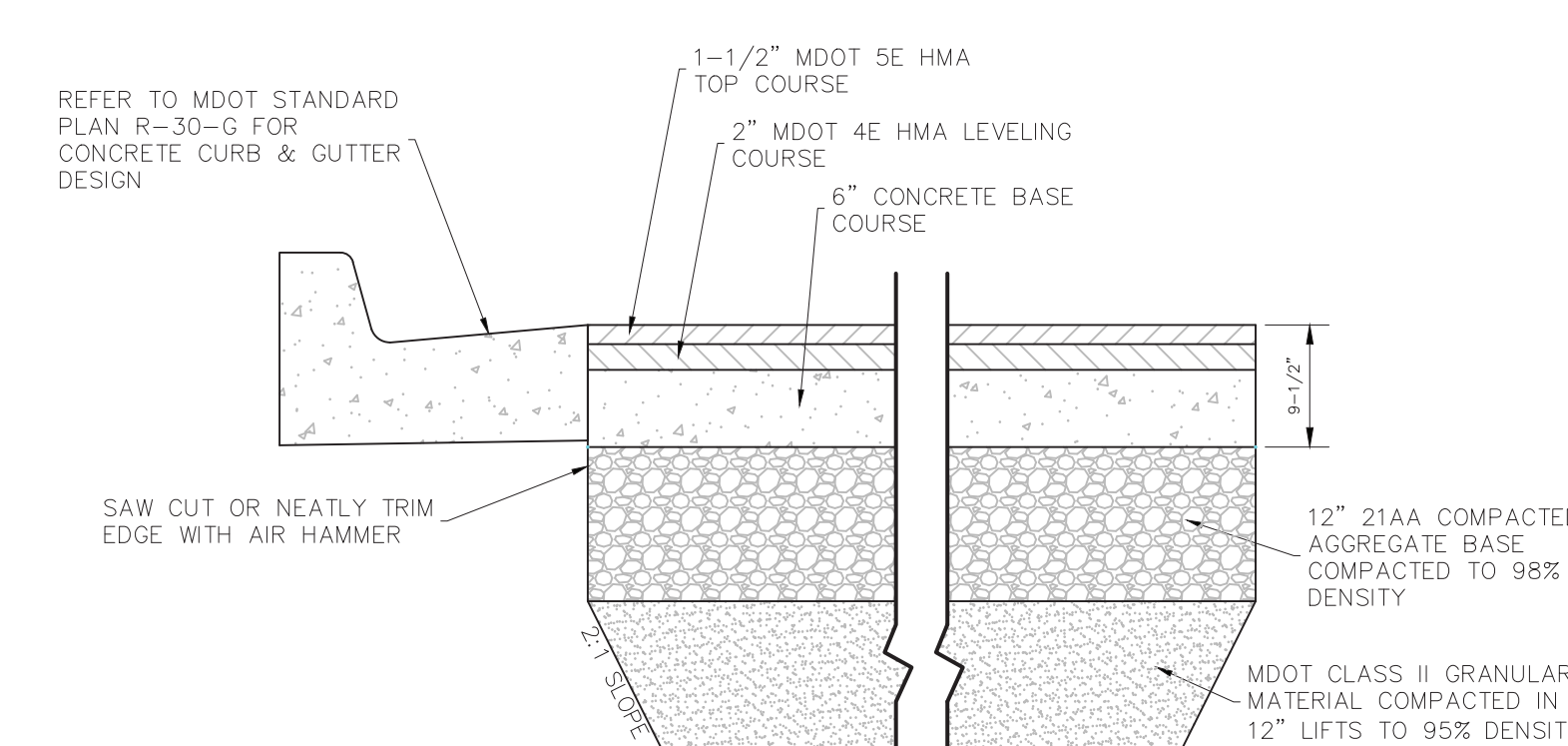

ASPHALT PAVEMENT WITH CONCRETE BASE DETAIL

- NOTE:
- *SS-1H @ 0.10/GAL/SYD BETWEEN LIFTS
 - PERFORMANCE GRADE BINDER TO BE USED: PG 64-28

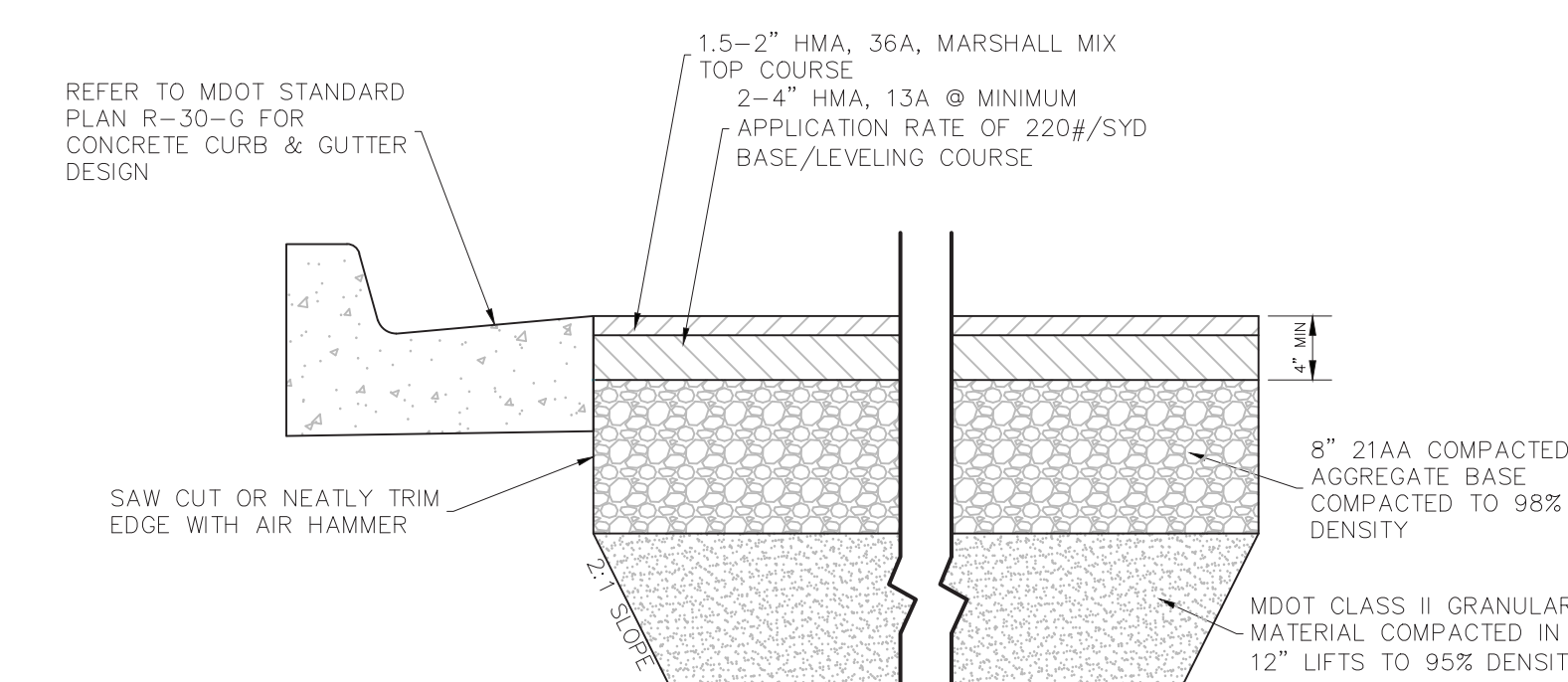

RESIDENTAL / LOW TRAFFIC VOLUME ROAD ASPHALT PAVEMENT DETAIL

- NOTE:
- *SS-1H @ 0.10/GAL/SYD BETWEEN LIFTS
 - PERFORMANCE GRADE BINDER TO BE USED: PG 64-28

**APPENDIX D
SPECIAL PROVISIONS**



**THE CITY OF KALAMAZOO
DEPARTMENT OF PUBLIC SERVICES
ENGINEERING DIVISION**

SPECIAL PROVISIONS

**DUKE STREET RESURFACING
(KILGORE TO DENWAY)**

Bid Reference #: 91396-017.0

CITY OF KALAMAZOO

SPECIAL PROVISION

FOR

PROGRESS CLAUSE

COK

Page 1 of 1

1/30/2023

- a.** The Contractor shall submit a complete, detailed and signed, Progress Schedule, to the Engineer, utilizing MDOT form number 1130.
- b.** The progress schedule shall include, at a minimum, the controlling work items for the completion of the project and the planned dates of the work items that will be the controlling operations. All contract dates including open to traffic, project completion, interim completion and any other controlling dates in the contract must be included in the progress schedule.
- c.** After receiving Notice of Award, start work within 10 calendar days after award or on a date approved by the Engineer. In no case, may any work be commenced prior to receipt of formal notice of award by the City.
- d.** The project must be open to traffic, including final site restoration, permanent pavement markings and signs, punch-list, and/or project clean-up on or before **September 1, 2023**
- e.** After award, and prior to the start of work, the Contractor must attend a preconstruction meeting with the Engineer. The Engineer will determine the day, time and place for the preconstruction meeting. The meeting will be conducted after project award and may be rescheduled if there are delays in the award of the project. The named subcontractor(s) for, Designated and/or Specialty Items, as shown in the proposal, is/are recommended to be at the preconstruction meeting if such items materially affect the work schedule.
- f.** Liquidated Damages shall be assessed in accordance with Section 108.10 of the MDOT Standard Specifications for Construction.
- g.** The Contractor may be required to meet for a post-construction review meeting, as directed by the Engineer. The Engineer will schedule the meeting.
- h.** Failure on the part of the Contractor to carry out the provisions of this Progress Clause may be considered sufficient cause to prevent bidding future projects with the City.

CITY OF KALAMAZOO

SPECIAL PROVISION

FOR

RELATIONS AND RESPONSIBILITY TO THE PUBLIC

COK

Page 1 of 1

1/30/2023

- a. Description.** The contractor shall notify the engineer when the first day of construction is planned no less than 10 business days prior to the start of the work. Following this correspondence, the City will issue a press release, media notice or other general form of notification to all the city's residents of the planned work. No work shall be performed prior to the issuance of this notice.

Additional notification shall be provided to the residents directly affected via door hanger notices no less than 72 hours before their street is planned to receive work. The contractor will provide preprinted door hanger material to carry the contractor's message. Message content must be approved by the engineer prior to printing and distribution. The responsibility for filling out the door hangers and distributing them will be the contractor's. Payment for this work will not be paid separately, but payment will be considered as having been included in the contract unit prices bid for other contract items. No work shall be performed prior to the distribution of these door hangers.

24 hours before every construction operation that will substantially affect a resident or business adjacent to the project site, (such as driveway closures, mailbox relocation, etc.) the contractor will notify residents or businesses affected. The contractor shall assist the City in coordination of work and mitigating impacts to the extent possible while maintaining construction schedules and ensuring project completion.

CITY OF KALAMAZOO

SPECIAL PROVISION

FOR

MAINTAINING TRAFFIC

COK

Page 1 of 4

1/30/2023

a. Description. This work shall consist of maintaining construction zone traffic and placing traffic control devices for the Duke St Reconstruction project and any affected side streets as described in this special provision and as directed by the Engineer in the City of Kalamazoo, Michigan.

b. Materials. Provide material in accordance with Sections 812 and 922 of the Michigan Department of Transportation (MDOT) Standard Specifications for Construction.

c. Storage of Materials. Location for storage of materials shall be addressed by the contractor in the City ROW permit and approved by the Engineer prior to the commencement of work. All maintenance of traffic materials shall be stored in the approved location(s). Any items not stored in the proper location shall be corrected no later than 24 hours after notice is given by the Engineer. Items found not stored in the approved locations or not corrected within the allotted time shall be grounds for the City to withhold payment for maintenance of traffic until corrected.

d. Construction. Traffic shall be maintained according to Chapter 6 of the Michigan Manual on Uniform Traffic Control Devices (MMUTCD) Guide to Sections 104.07, 104.11, 812, and 922 of the MDOT Standard Specifications for Construction, including any Supplemental Specifications, and as specified here.

1. The Contractor shall notify the Project Engineer a minimum of 72 hours prior to the implementation of any detours, road closures, shoulder closures, or lane closures.

2. The Contractor shall coordinate his operations with Contractors performing work on other projects within or adjacent to the Construction Influence Area (CIA).

3. City of Kalamazoo (City), maintenance crews and/or Contract Maintenance Agencies may perform maintenance work within or adjacent to the CIA. The City and/or Contract Maintenance Agency will coordinate their operations with the Engineer to minimize the interference to the Contractor. No additional payment will be made to the Contractor for the joint use of the traffic control items.

4. The Contractor shall provide a traffic control plan for each phase of the project to the Engineer for approval by the Traffic Safety Department and the Engineer prior to beginning work requiring traffic control. The traffic control plan shall include all temporary signage, type II barricades, type III barricades, plastic drums, etc. and appropriate temporary pavement markings where needed.

5. Construction Influence Area (CIA). The CIA shall include the right-of-way of the following roadways, within the approximate limits described below:

- A. Duke St: Kilgore Rd to Whites Rd
- B. Denway Dr: Duke St to Westnedge
- C. All side streets coming off Duke St from Kilgore Rd to Whites Rd

6. Traffic Restrictions and Construction Requirements.

A. All work shall be conducted during daytime hours unless otherwise specified herein or approved by the Engineer. Night work may be permitted at the discretion of the Engineer. However, any additional cost for such work shall be borne by the Contractor.

B. Access for construction vehicles between the travel lanes and work areas will be restricted to specific locations. The number of access points and their locations will require the prior approval of the Engineer.

C. Undercuts or excavations immediately adjacent to active traffic lanes shall be restored to no less than a 1 on 4 slope at the end of each working period unless otherwise approved by the Engineer. Fencing shall be required to protect open trenches during non- working hours and shall be provided by the Contractor as part of the trenching item utilized.

D. Duration of driveway and alley closures shall be minimized. Contractor shall provide property owners with written notice a minimum of four (4) business days prior to the anticipated driveway and alley closure, and shall inform residents of the anticipated duration of the driveway or alley closure.

E. The Contractor shall maintain and coordinate daily waste pickup and deliveries to all business buildings affected by driveway, alley and road closures for this project.

F. Sidewalks or pathways in the project area shall be maintained at all times except in areas where sidewalk or pathway removal and replacement are ongoing. Sidewalk or pathways removed shall be replaced as soon as is feasibly possible.

G. Ingress and egress to all buildings and parking areas for pedestrians and vehicles shall be maintained.

H. Keep all side streets and alleys free of construction related materials, equipment, and activities to allow clear visibility and access to all properties and businesses.

I. Contractors, employees, and subcontractors shall not park vehicles or store equipment in areas that are needed for residential or adjacent commercial parking and at no time shall vehicles be parked or equipment stored on private property unless written permission is obtained from the property owner. Also, Contractors, employees and subcontractors shall not drive construction equipment of any kind on private property without written permission of the property owner.

J. Construction equipment and material storage shall not be allowed on top of existing areaways, pathways or sidewalks.

K. Street name signs shall be maintained within the construction area for the duration of the project. Street name signs shall be visible from all intersection corners. If the existing street name sign and support are to be removed, and there is no alternate support available, the Contractor shall erect a separate post & street name sign for this

purpose. The cost for this work shall not be paid for separately but considered incidental to the pay items included for maintaining traffic.

L. Removing, obstructing, relocating or otherwise tampering with a regulatory traffic sign is prohibited unless approved by the Engineer and the City Traffic Safety Department. Where a conflict is foreseen or encountered, the sign(s) may be removed by the Contractor only upon installation of temporary signs(s) placed in accordance with the Michigan Manual of Uniform Traffic Control Devices (MMUTCD) at location(s) approved by the Engineer. Temporary signs shall be maintained by the Contractor until the existing permanent signs are reinstalled. The cost for this work shall be incidental to the pay items included for maintaining traffic.

7. Traffic Control Devices.

A. General

- i. All traffic control devices and their usage shall conform to the most current revision of Part 6 of the Michigan Manual of Uniform Traffic Control Devices (MMUTCD).
- ii. During non-working periods, any work site with uncompleted work shall have advance signs (W21-4 - "Road Work Ahead") and plastic drums, at specific locations, as directed by the Engineer.

B. Temporary Signs

- i. Tables for "L", "D" and "B" values are provided in MDOT Traffic and Safety Figure M0020a.
- ii. Temporary signs shall be on ground driven sign supports as shown in MDOT Traffic and Safety Figure WZD-100-A.
- iii. The signing for a one or two lane closure and traffic shift shall be as shown in the MDOT Traffic and Safety Figure M0240a and M0120a..
- iv. All diamond-shaped warning signs shall be 48 inch x 48 inch mounted at a 7 foot minimum bottom height in curbed or pedestrian areas.
- v. Distances between construction warning, regulatory and guide signs shown on the Figures are approximate and may require field adjustment, as directed by the Engineer.
- vi. All temporary signs shall be constructed with legends and symbols flush to the sign face and not extending beyond the sign borders or edges.
- vii. All temporary signs shall be faced with prismatic retroreflective sheeting.
- viii. If necessary, the City will provide temporary neighborhood business signage (sign board only) for the purpose of directing the public to the various businesses within the

Construction area. The Contractor shall be responsible for the installation, maintenance, and relocation of these signs as necessary to coincide with the various phases of the project. If included in the contract, the cost to install, maintain, and relocate these signs will be paid for under the item "Install and Maintain Temporary Neighborhood Business Signs".

ix. Whenever a lane or obstruction is removed, all related construction signs shall be removed, turned away from traffic or otherwise made not visible to traffic.

C. Channelizing Devices

- i. Channeling devices required for maintaining one lane of traffic in each direction shall be Channelizing Device, 42 inch.

e. Measurement and Payment. The completed work shall be paid for at the contract unit price which shall include all materials, equipment and labor required to complete this work. Pay items are listed in the contract and invitation for bid documents.

CITY OF KALAMAZOO

SPECIAL PROVISION

FOR

CURB AND GUTTER, REM, SPECIAL

COK

Page 1 of 1

1/30/2023

- a. **Description:** Work for the item of Removing Curb and Gutter - Special shall consist of the removal of the existing variable width curb and gutter to a neat clean line to facilitate the placement of new concrete curb and gutter.
- b. **Construction Methods:** The existing pavement shall be saw cut full depth at a distance of two (2) feet from the existing edge of pavement prior to the removal of the existing curb and gutter. Once the pavement has been cut, the existing curb and gutter and adjacent two (2) feet of pavement will be removed. Removed section of roadway shall be restored per City standard detail following placement of new curb & gutter. Care will be taken not to disturb the pavement that is to remain in place.
- c. **Measurement and Payment:** Removing Curb and Gutter - Special shall be paid at the unit cost per lineal foot. Measurement will be made along the edge of pavement prior to removal. All work involved including saw cutting, removal and disposal shall be included in the unit price.

<u>Pay Item</u>	<u>Unit</u>
Curb and Gutter, Rem, Special	Foot

CITY OF KALAMAZOO

SPECIAL PROVISION

FOR

DR STRUCTURE COVER, ADJ, CASE 1, MODIFIED

COK

Page 1 of 2

1/30/2023

a. Description. This work consists of removing and replacing existing City of Kalamazoo owned manhole structure covers during HMA surface operations with City of Kalamazoo standard covers. This operation uses the Mr. Manhole™, Manhole Leveling System, or equivalent. Section references are to the current version of the MDOT Standard Specifications for Construction.

b. Materials. Provide materials in accordance with the following:

Cover and Casting: Supply the City of Kalamazoo standard design cover and casting for Sanitary and Storm sewer meeting the requirements of Section 908 and COK special provision “Dr Structure Cover, Type _, Modified”.

Concrete: Use Grade P-NC concrete meeting the requirements of Section 1006.

Mortar Type R-2: Use mortar meeting the requirement of Section 1005.

HMA: Use HMA mixtures as specified in the special provisions

c. Construction Methods. Remove existing pavement around the drainage structure using the Mr. Manhole™ or equivalent system. Remove the existing drainage structure in a manner to avoid roadway materials from entering the manhole structure. Salvage existing manhole covers and castings if in good condition; otherwise replace the casting and cover. If pickup is needed, notify the Engineer when manhole cover and casting are ready for pickup. Place a steel plate over the manhole structure and fill in the resulting void with the HMA mixture or material approved by the Engineer. Record the location of each structure and use a locating system or GPS record of each structure for finding it following final paving.

Prior to paving, ensure that locations of structures are confirmed & recorded, and any markers or caps used are in place to easily identify and find each structure after final paving. Upon completion of final paving, cut out and remove the pavement around the structure using the Mr. Manhole™ or equivalent system. Avoid roadway materials from entering the manhole structure. Remove the plate and locator cap. Set the new structure cover in a full bed of mortar or using custom adjusting rings built for this purpose. Adjust in accordance with manufacturer’s instructions, MDOT Standard Specifications, and best practices. Set the structure cover level with the roadway (nominal offset = 0”, maximum offset = +/- 1/8”). Fill in resulting void with concrete meeting the requirements of Section 1006. Assume ownership of excess removed materials and dispose of according to subsection 205.03P.

Any material entering the Sewer system must be removed promptly. If the contractor neglects to remove the material within 7 days for storm or 24 hours for sanitary after receiving written notification from the Engineer, the Engineer may proceed with the removal. The Engineer will deduct the cost of the removal from the monies that are or may become due to the contractor.

d. Measurement and Payment. The completed work, as described, will be measured and paid for at the contract unit price using the following pay item:

Contract Item (Pay Item)	Unit
Dr Structure Cover, Adj, Case 1, Modified	Each

The unit price for Dr Structure Cover, Adj, Case 1, Modified includes all labor, equipment, and material to remove the existing pavement, install the new cover and casting, and place the concrete collar.

CITY OF KALAMAZOO

SPECIAL PROVISION

FOR

DR STRUCTURE COVER, TYPE __, MODIFIED

COK

Page 1 of 1

1/30/2023

a. Description. This work consists of furnishing City of Kalamazoo sanitary and storm sewer structure covers during construction operations in accordance with Section 403 of the MDOT Standard Specifications for Construction.

b. Materials. Provide materials in accordance with the following:

1. **Cover and Casting:** Supply a Dr Structure Cover, Type __, and Modified in accordance with City of Kalamazoo Specifications for Sanitary and Storm sewer meeting the requirements of Section 908 of the MDOT Standard Specifications for Construction.
2. **Cover Q (Storm Sewer)** - shall consist of an EJIW 1045ZPT (bolted) frame with a 1040A (non-bolted) *Non-Vented* Cover with 2 inch “STORM SEWER” lettering or approved equal.
3. **Cover S (Sanitary Sewer)** – shall consist of an EJIW 1045ZPT (bolted) frame with a 1040A (non-bolted) Cover with 2 inch “SANITARY SEWER” lettering or approved equal.
4. **Concrete:** Use Grade P-NC concrete meeting the requirements of Section 1006.
5. **Mortar Type R-2:** Use mortar meeting the requirement of Section 1005.

c. Construction Methods. Refer to COK special provision “Dr Structure Cover, Adj, Case 1, Modified” for construction methods.

d. Measurement and Payment. The completed work, as described, will be measured and paid for at the contract unit price using the following pay item:

Contract Item (Pay Item)

Pay Unit

Dr Structure Cover, Type __, ModifiedEach

The unit price for Dr Structure Cover, Type __, Modified includes supplying the new cover and adjustment rings to be placed and adjusted per COK special provision “Dr Structure Cover, Adj, Case 1, Modified”.

CITY OF KALAMAZOO

SPECIAL PROVISION

FOR

GATE BOX, ADJUST, CASE 1, MODIFIED

COK

Page 1 of 1

1/30/2023

a. Description. This work consists of adjusting gate boxes in accordance with Subsection 403.03C and 823.03 of the MDOT Standard Specifications for Construction.

b. Materials. Use MDOT P-NC Concrete with no fly ash and coarse aggregate 6AA meeting the requirements of section 603.

c. Construction Methods. Adjust gate box according to subsection 823.03 and place a concrete collar around the adjusted structure. The concrete shall be uniformly placed around the valve box so it is flush with the top of the final HMA course.

d. Measurement and Payment. The completed work, as described, will be measured and paid for at the contract unit price using the following pay item:

Contract Item (Pay Item)

Pay Unit

Gate Box, Adjust, Case 1, Modified

EA

The Unit price for Gate Box, Adjust, Case 1, Modified includes all material, labor and equipment to saw cut and remove pavement, adjust the gate box to final grade, replace and re-compact disturbed soils, and place the concrete collar.

CITY OF KALAMAZOO

SPECIAL PROVISION

FOR

GATE BOX, RECONSTRUCT, MODIFIED

COK

Page 1 of 1

1/30/2023

a. Description. This work consists of furnishing and placing a gate box centered, plumbed, and adjusted to the required pavement grade over the existing gate valve.

b. Materials. Provide materials in accordance with the following:

Gate Box: Shall be an adjustable length screw type for 5-foot depth of cover. The Gate box shall be a malleable iron casting conforming to Subsection 908.03 of the Michigan Department of Transportation (MDOT) *Standard Specifications for Construction*. This valve box shall be either a two or three-piece screw type and the cover shall be inscribed with the word “water.” Valve box shall be EJ 8550 Series (two piece) or EJ 8560 Series (three piece), or Bingham & Taylor 4905 size no. 22, or approved equal.

Gate Valve Box extensions shall be cast iron and manufactured by EJ of Bingham & Taylor, capable of being mounted directly to the gate valve box.

Concrete: Use MDOT Grade P-NC concrete with no fly ash and coarse aggregate 6AA meeting the requirements of Section 601.

Masonry Unit: Use Masonry units meeting the requirement of Section 913.

Granular Material Class II: Use Granular Material Class II meeting the requirements of Section 902.

c. Construction Methods. Remove pavement around the existing gate box and remove gate box in accordance with Section 204. Salvage existing gate box and place in a secure location for pick up and notify the Engineer when all gate boxes are ready for pick up. Place four (4) evenly spaced masonry units around gate valve ensuring the gate box rests on the masonry units and not the gate valve. Install gate box level and plumb. Backfill in accordance with Subsection 204.03 ensuring the gate box does not shift during backfilling. Adjust cover to final grade and place concrete uniformly around the gate box flush with the top of the pavement surface.

d. Measurement and Payment. The completed work, as described, will be measured and paid for at the contract unit price using the following pay item:

Contract Item (Pay Item) Pay Unit

Gate Box, Reconstruct, Modified.....Each

The unit price for Gate Box, Reconstruct, Modified includes all labor, equipment, and materials to remove the existing pavement and backfill, supply and install the gate box, backfill and compact, and place the concrete collar.