

Pilot Cycle Tracks



What Will The Pilot Cycle Tracks Look Like?



Ann Arbor - Miller/Catherine aerial image, 2023



Ann Arbor –
S. Division St:
aerial image, 2023

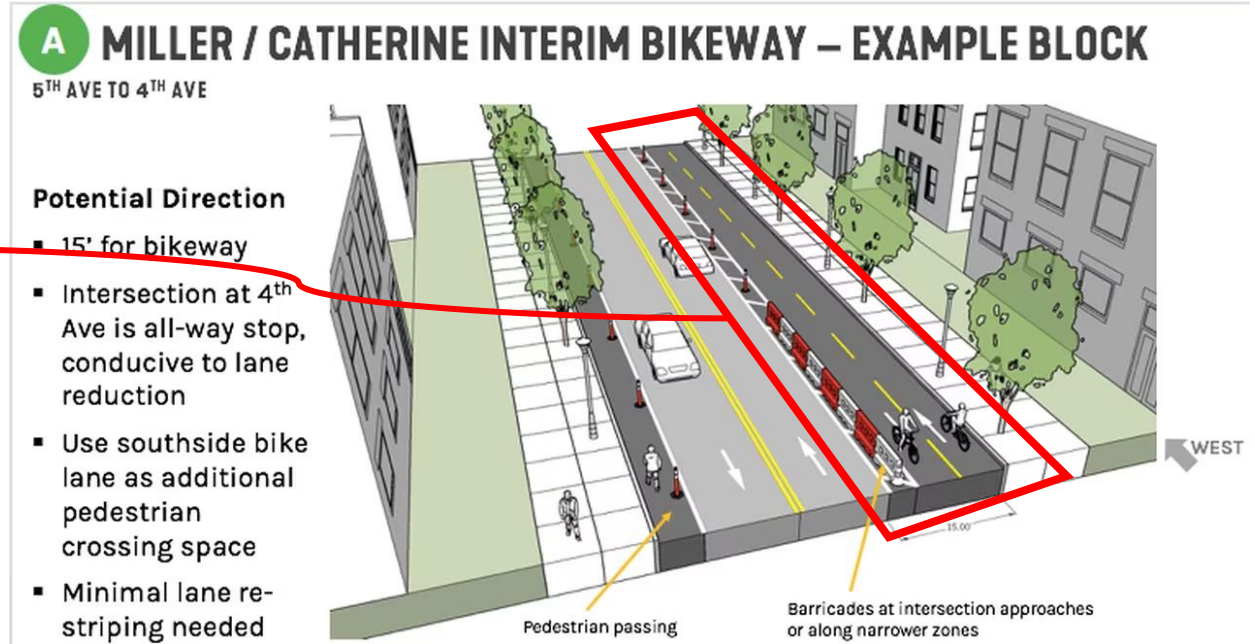

More bike lanes, fewer car lanes planned in downtown Ann Arbor as DDA reimagines streets - mlive.com

Pilot Cycle Tracks

- Two-way bicycle traffic
- Buffered with flush-mount rubber curb
- Crossings collocated with pedestrians



What Will The Pilot Cycle Tracks Look Like?



Ann Arbor – S Division Before Change: Parking!



Ann Arbor – What permanency looks like on Miller



Ann Arbor – S Division After Change: No Parking!

What Will The Pilot Cycle Tracks Look Like?

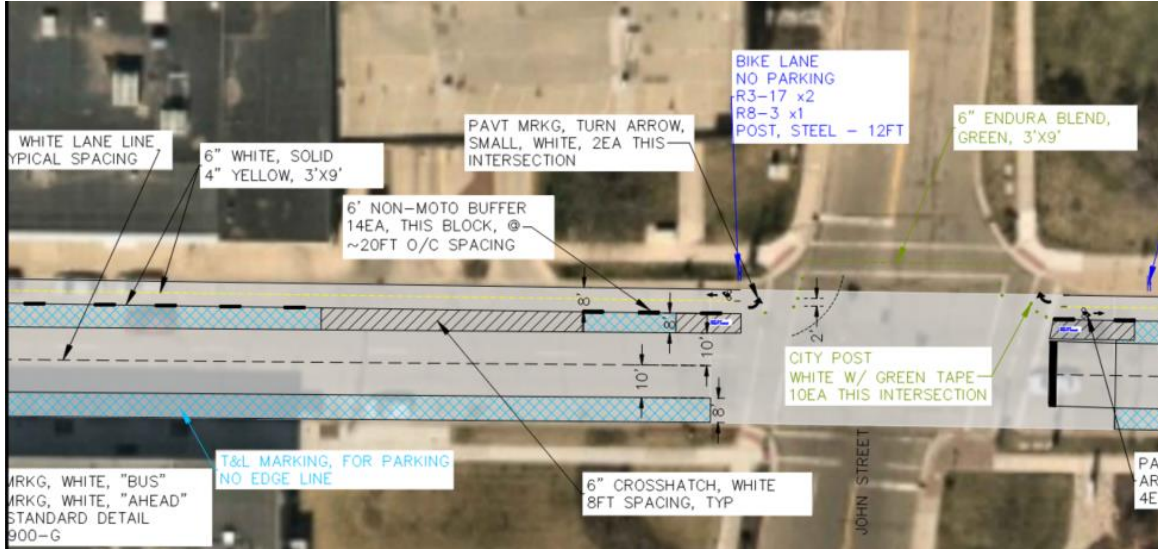

Lovell St Detail – Engineering Plans

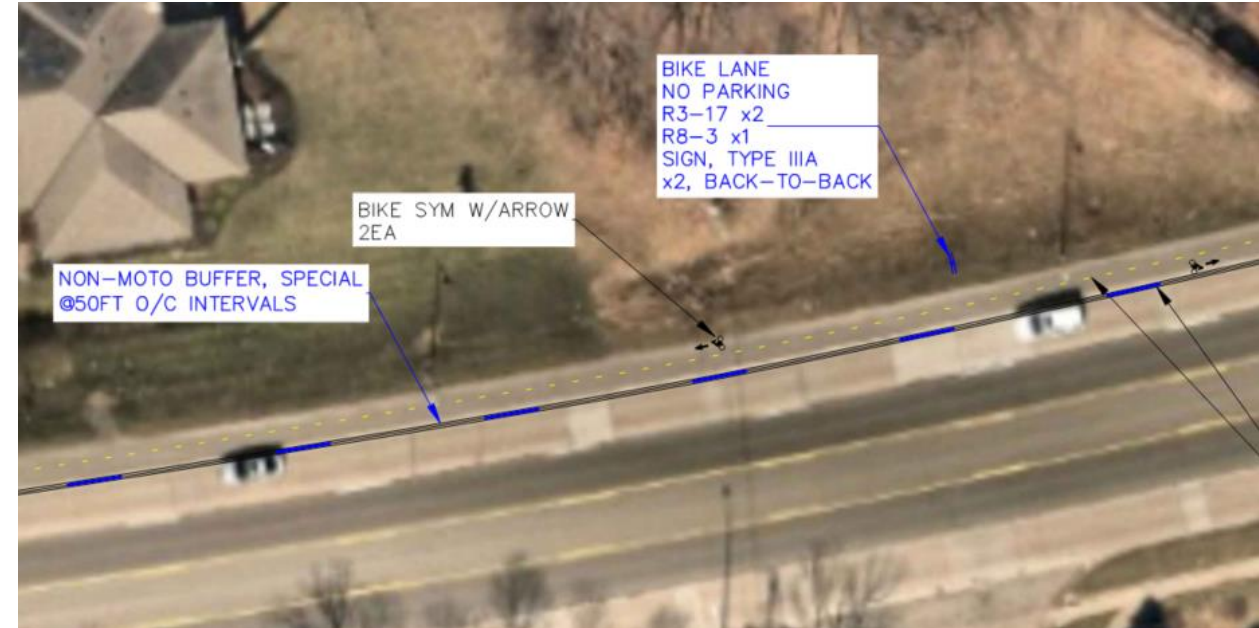

Stadium Dr Detail – Engineering Plans



Portage St Bike Lane Addition

Pilot Cycle Tracks

- Two-way bicycle traffic
- Buffered with flush-mount rubber curb
- Crossings collocated with pedestrians



Protected Cycle Facilities



What Will The Protected Cycle Facility Look Like?

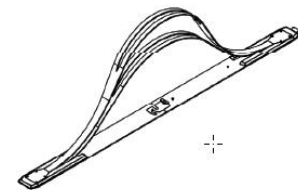
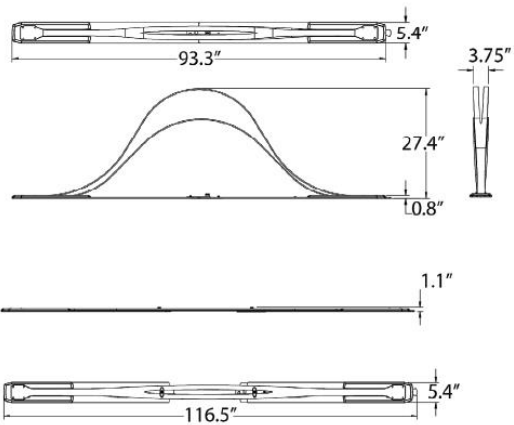

Bike wave delineators by Saris ©

- Placed out during warmer months
- Removed for winter maintenance
- Spaced to permit drive access
- Adaptable format



Speed Humps & Speed Tables



What Will The Speed Humps/Tables Look Like?



Speed Humps/Tables in Asphalt

- Speed Bumps Design Speed = 15mph
 - Width: 12ft
 - Height: 3.5"
- Speed Table Design Speed = 25mph
 - Width 22ft, minimum
 - Height 3.5"



Mini Roundabouts



What Will The Mini Roundabouts Look Like

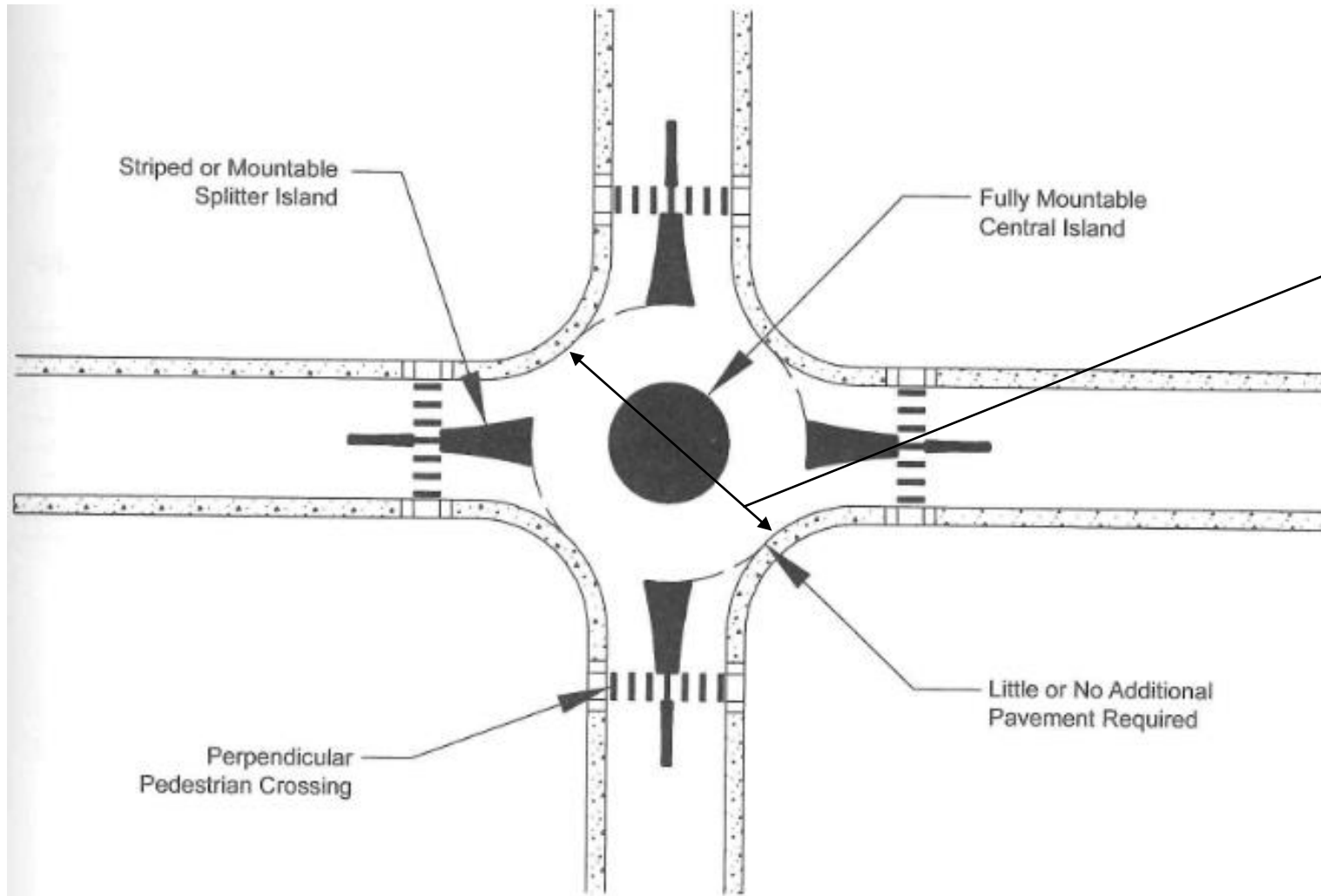

Typically, 45-90ft in diameter

COK diameters vary from 60ft (min) to 80ft for SS4A

Figure 9-12. Typical Mini-Roundabout

From AASHTO Greenbook



What Will The Mini Roundabouts Look Like

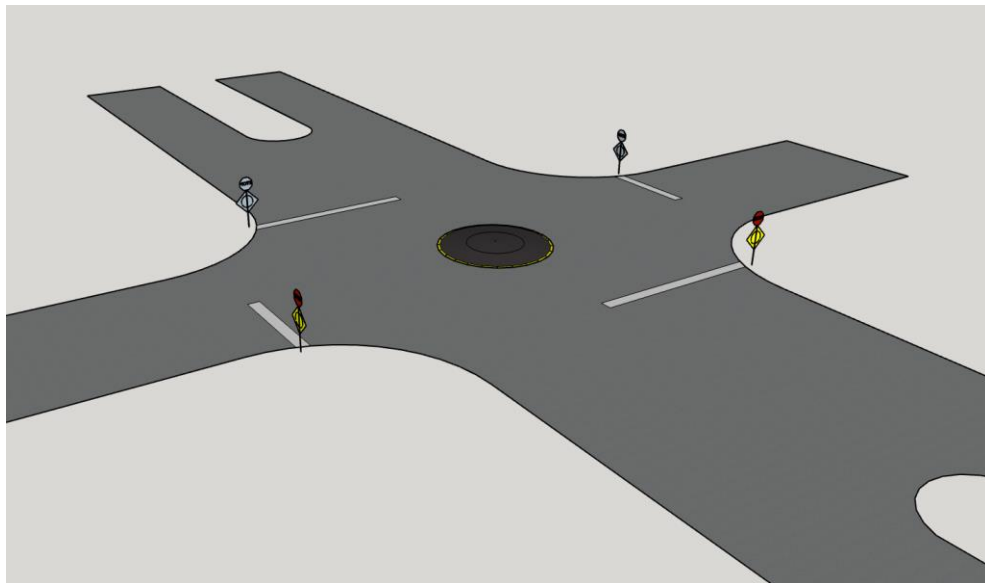
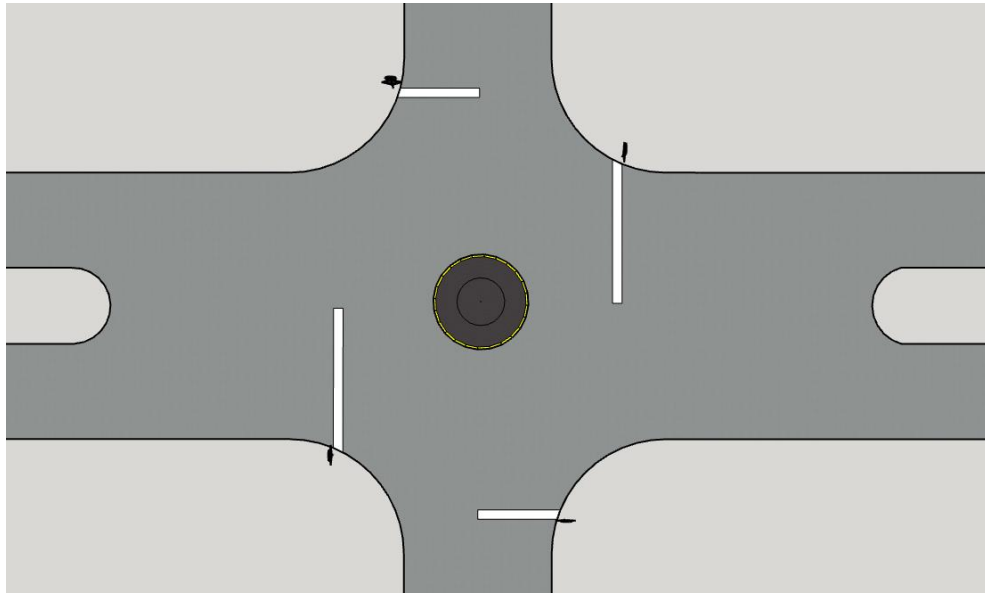

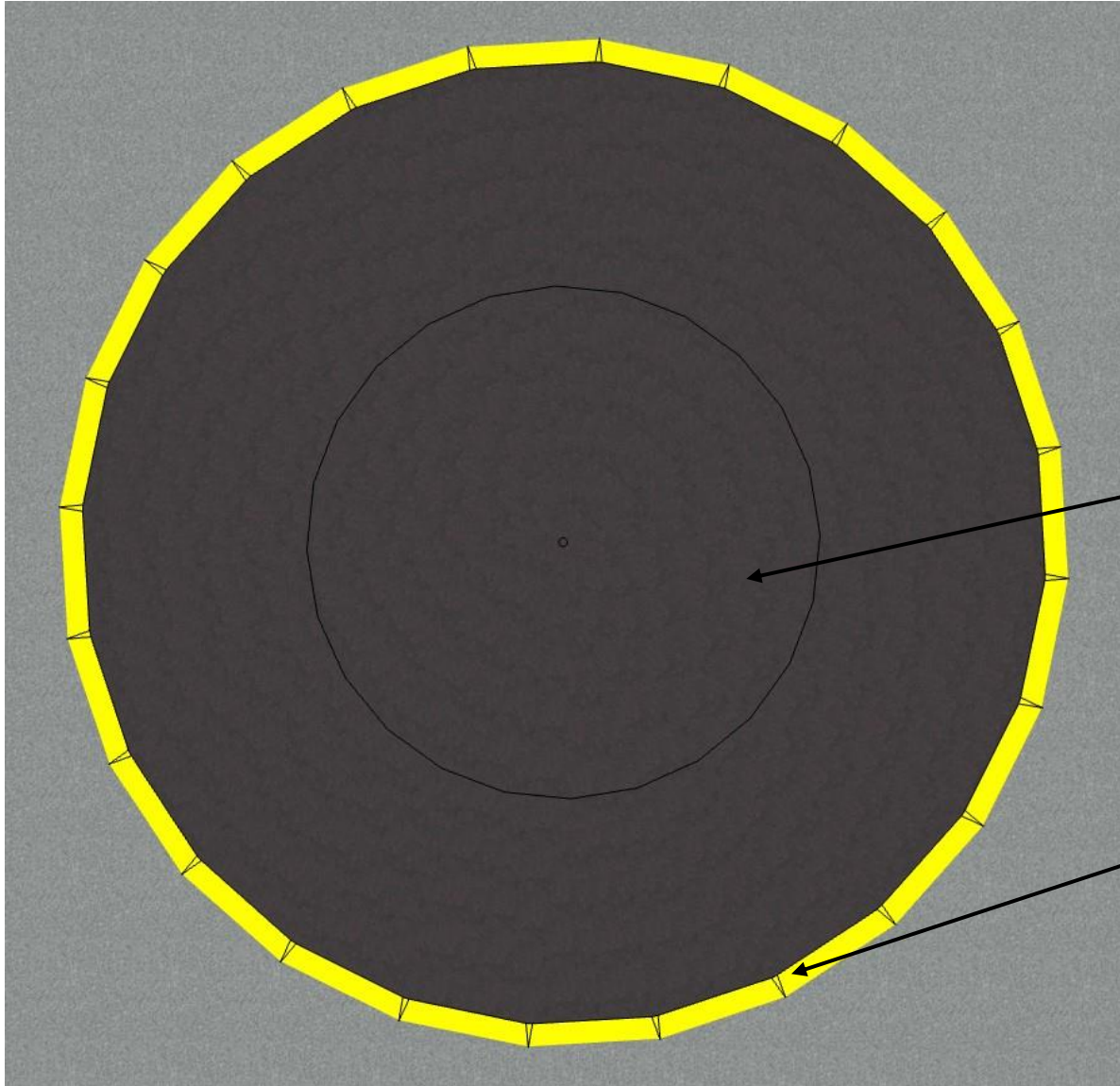

Interior asphalt of the roundabout can accommodate customization by the community via future beautification and artistic efforts.

Yellow Non-Removable Pavement Marking Tape



How do You Use a Mini Roundabout

The mini roundabouts will work like a roundabout... just smaller. The roundabout will be made out of asphalt and are capable of being driven on.



Mini Roundabout Timeline



Future state of what a permanent design could be...

The mini roundabouts are a part of a 3-year pilot and scheduled to be installed in 2024. The project will be evaluated biannually.



What do Mini Roundabouts Do



Roundabout

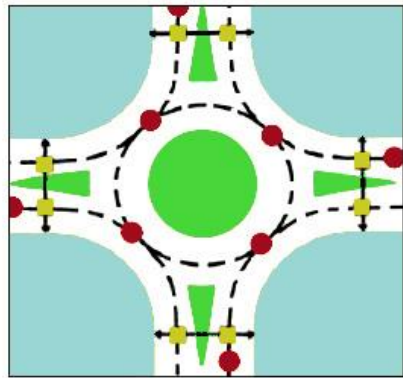

● 8 Vehicle conflicts
■ 8 Pedestrian conflicts

Intersection

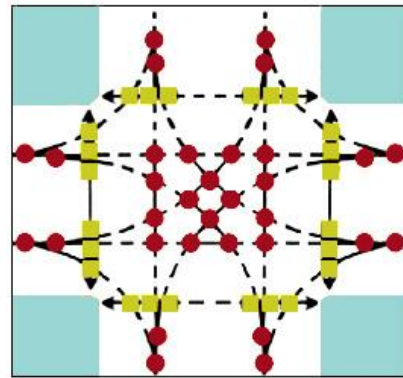

● 32 Vehicle conflicts
■ 24 Pedestrian conflicts

Mini roundabouts and neighborhood traffic circles lower speeds at minor intersection crossings and are an ideal treatment for uncontrolled intersections. Mini roundabouts have been shown to increase safety at intersections.



Pilot
Pedestrian
Refuge Areas



What Will The Pedestrian Refuge Areas Look Like



More Info

- For more information on Mini Roundabouts and other neighborhood plans visit
- [Safe Streets For All Traffic Calming Grant City of Kalamazoo \(kalamazoo.org\)](https://www.kalamazoo.org/transportation/safe-streets-for-all-traffic-calming-grant)

