

# Station Hydrants Project Specifications

## GENERAL

The intent of this project is to install fire hydrants at six City of Kalamazoo water pump stations.

Owner = City of Kalamazoo  
Engineer = Anna Crandall, PE

### 1. SPECIFICATIONS

The work under this contract shall be performed in accordance with these Project Specifications and the City of Kalamazoo Standard Specifications for Water Main and Service Installation dated 6/14/2021, unless noted otherwise on the plans.

In the event of a conflict between the Standard Specifications and these Project Specifications, the Project Specifications shall prevail.

The Michigan Department of Transportation Standard Specifications for Highway Construction 2012 Edition are included by specific paragraph reference.

### 2. PROJECT AREA

The Contractor shall confine his work to the project area needed for the work. Any other area required for equipment, material storage or for construction operation shall be the Contractor's responsibility. The Contractor shall receive written permission from the Owner's of adjacent properties before using any portion of the property outside the project area.

The Contractor shall take all necessary precautions to minimize disturbances to the area during the construction period. All damage caused by the Contractor or sub-contractors to the property outside the project area shall be repaired at no expense either to the property owner or to this project.

### 3. SUMMARY OF WORK

Work to be constructed in this project generally includes furnishing and installing the following:

- Large Tap
- Hydrant Installation
- Lawn Restoration
- Vault Removal

All labor, materials, equipment, transportation, and activity or costs necessary for completion of this work shall be included in this contract unless specifically stated otherwise.

4. PERMITS

Owner will obtain all necessary permits.

5. SCHEDULING

The Contractor shall file a construction schedule with the Engineer and Owner and receive approval in writing prior to commencing construction.

The Contractor and the Construction Observer shall coordinate/communicate schedule of shut down and reconnection of service with Resident/Bill Payer for each property.

Project Deadline:

**June 30, 2023**

All costs associated with scheduling shall be considered incidental to the project.

6. MAINTENANCE OF TRAFFIC

Local traffic shall be maintained at all times during construction. All traffic control devices and placement shall be in accordance with the current MDOT Standards and Specifications for Construction or as directed by engineer.

During the progress of work, the Contractor shall accommodate vehicular traffic in road rights-of-way as provided in these specifications. Access to fire hydrants, water and gas valves shall be maintained at all times during construction.

Where streets and driveways are obstructed, the contractor shall place and maintain temporary driveways, ramps, etc., which, in the opinion of the Engineer, are necessary to accommodate the public. The Contractor shall provide access at night and on weekends for all properties in the immediate construction area.

Emergency vehicle access shall be maintained at all times.

The Contractor shall be required to keep the surface of the roadway in a smooth, dust free and accessible condition for adjoining properties at all times. Dust control shall also apply to paved roads in the project area and are to be kept clean by the use of a mechanical sweeping device. Maintenance shall consist of grading the disturbed or graveled surface and maintaining the surface free of “wash- boards” and “chuck-holes”, suitable for traffic.

The Contractor shall inform the schools, local police, ambulance services and fire department in advance of his program of street obstruction and detours. Detouring and construction signing shall be in accordance with Michigan Manual of Uniform Traffic

Control at the direction of the Owner.

Prior to construction the Contractor shall submit and obtain Owner approval for his traffic control plans, including detour plans and schedules.

The Owner must approve all detours. The Contractor shall pay for all costs of detours. All costs shall be included under proposal item "Traffic Control".

Cost of maintaining traffic including detouring, construction signing, and traffic control shall be paid as specified in the proposal form.

7. LIMITATION ON OPERATIONS

The Contractor shall at all times conduct his work so that there is a minimum of inconvenience to the residents, businesses and industries within the project area. Work on Road Commission of Kalamazoo County (RCKC) roads shall be limited to April through November.

8. PROTECTION OF WORK

The Contractor shall protect the work until it is accepted by the Engineer. Any part of the completed work that is damaged prior to acceptance by Engineer shall be replaced at the Contractor's expense.

9. DUST CONTROL

All haul roads, detour roads and other public and private roads (including backfilled trenches), driveways and parking lots used by the Contractor must be maintained in a dust free condition during the life of this Contract. The control of dust shall be accomplished by sweeping and by the application of dust control materials. The materials and methods of application shall be approved by the Engineer and shall be applied as often as is necessary to control the dust, or if directed to do so by the Owner's representative. If directed to do so, the Contractor shall complete the dust control measures within 24 hours. All spillage on public roadways used as haul routes shall be cleaned daily.

Costs of providing dust control shall be included in the major items of construction. Therefore, no additional payment shall be made.

10. MATERIAL HAUL ROADS

Any spillage on public roadways used as haul routes shall be cleaned daily.

Use of gravel roads is prohibited. Permission to use gravel roads shall be given to Contractor only if Contractor assumes responsibility of maintenance, dust control and restoration of the gravel roads to the satisfaction of the Owner.

## 11. TOPSOIL STRIPPING

The Contractor shall perform clearing, grubbing and stripping of topsoil. Stripped topsoil shall be stockpiled on the site. The Contractor shall be allowed to use this stockpiled material when placing topsoil on the site and shall provide additional topsoil as necessary to meet the thickness specified. No fill shall be placed over topsoil or organic material. At completion of construction, topsoil shall be spread uniformly over the disturbed areas. Any excess topsoil shall become the property of the Contractor and properly disposed of offsite. The cost of the above requirements shall be included in the price of the major items of work.

## 12. PROTECTION OF NATURAL RESOURCES

The Contractor shall take all necessary steps to prevent damage to fish and game habitats and to preserve the natural resources of the State. Excavation and backfill shall be carried out so as to minimize discharge of damaging material into any stream, lake, or reservoir.

The Contractor shall exercise caution in the discharge of waters from pumps, deep wells, or well point systems in order that such discharges do not cause erosion, siltation, soil depositions, etc., in sewers, streams or other water courses or drainage structures.

The Contractor shall not permit any sand or debris of any kind to enter the existing ditches, streams, storm sewers or culverts.

The rules and regulations of all work shall comply with Part 301 (Inland Lakes and Streams Act), Part 91 (Soil Erosion and Sedimentation Control Act), and Part 303 (Wetlands Protection Act) of Michigan Public Act 451, 1994.

## 13. SOIL EROSION AND SEDIMENTATION CONTROL(Part 91, P.A. No. 451)

All work shall comply with the rules and regulations of the Michigan Soil Erosion and Sedimentation Control Act (Part 91, Michigan Public Act No. 451, 1994). These measures have been developed from the Michigan Unified Keying System, described in "Michigan Soil Erosion and Sedimentation Control Guide Book" published by the Land and Water Management Division of MDEQ.

All of these measures shall be in place prior to excavating where required and shall be maintained until construction is complete except 6, "seeding with mulch matting" or aggregate cover, which shall be done immediately after the pipe installation.

The cost of the above requirements shall be included in the price of the major items of work.

14. DEWATERING

When dewatering of groundwater is required, the Contractor shall limit the dewatering operation to the minimum time and depth required for construction. The Contractor shall submit to the Owner a dewatering plan indicating how dewatering will be accomplished, along with how and where dewatering discharge will be directed and controlled. Dewatering flows shall not be directed immediately to any watercourse. All flow shall be directed to an “ecolobag” or Engineer approved equal sediment trap. The sediment trap shall be located to allow a minimum overland flow 100 feet prior to entering any water course.

Dewatering shall be included in the price of the major items of work.

15. EXCESS DIRT

The Contractor shall remove all excess material resulting from construction and arrange for disposal at a suitable site. Excess material shall be the property of the Contractor and shall be disposed of properly by the Contractor.

16. USE OF SLAG

No slag shall be permitted.

17. CLEARING AND GRUBBING

This shall include all clearing and grubbing of lands required to complete the Work as specified, shown in the Contract Documents, and as directed by the Engineer. This Work shall include, but not limited to, the complete removal of all vegetation including plants, shrubs, sod, agricultural crop residue, trimming and cutting of trees with trunk diameter less than 6-inches, removal of tree cuttings and stumps, scalping and the removal and disposal of all debris generated by the clearing and grubbing operation as specified. Payment for this item shall be included in the major items of work.

18. EXISTING UTILITIES

As an aid to the Contractor, various utilities and underground structures are shown on the plans. All information concerning shown utilities were taken from field topo and from available records, but the Owner and the Engineer do not guarantee that the location shown on the plans is accurate, nor that additional underground utilities or structures may not be encountered.

The Contractor shall notify Miss Dig and Utility Companies for utility locations before starting any open cut or tunnel construction or before drilling holes for construction purposes. This does not relieve the Contractor of notifying utility owners who may not be part of the Miss Dig alert system. He shall cooperate with the utility companies in any repair, relocation or other work to be performed on the utility caused by the construction of the contract.

The Contractor shall be fully responsible for the location, protection, relocation, replacement, etc. for all existing underground utilities which may reasonably be expected in any area, regardless of whether or not such utilities are shown on the plans. Items in this category shall include, but not necessarily be limited to; water mains and services, gas mains and services, storm sewer and catch basin leads, telephone, electric, and cable TV wire, etc. Such work shall be considered incidental to the major items of construction unless otherwise noted on the construction drawings.

A. Contractor shall coordinate with the Owner to locate all private utilities.

B. Sewers (Storm, Culverts, and Under drains)  
RCKC provides storm sewer service in the project area.

C. Sanitary Sewer  
City of Kalamazoo provides sanitary sewer service in the project area.

D. Water Main  
City of Kalamazoo provides water service in the project area.

E. Cable  
Charter Communications provides cable service in the project area.

F. Electric Services  
Consumers Energy operates the electrical system in the project area.

G. Gas  
Consumers Energy provides natural gas service in the project area.

H. Telephone  
AT&T Michigan provides telephone service in the project area.

I. Miss Dig  
The Contractor shall contact "MISS DIG" not less than 72 hours before starting construction for assistance in locating utilities or for any work to be done on utilities. The toll-free phone number is (800) 482-7171.

## 19. PROTECTION OF UTILITIES

The Contractor shall furnish, install, use, and maintain adequate sheeting, shoring, bracing, and stabilization methods required to ensure the integrity of existing underground utilities both during and after completion of construction. When necessary, the Contractor shall shore and brace existing utility poles which interfere with construction.

The Contractor shall be responsible for repairing all cracks, leaks, breaks, and defects

in the utilities during the standard contract guarantee period of two year after acceptance of construction, at no additional cost either to the project owner or the owner of the utility.

Should service provided by public utilities be interrupted by the Contractor, the Contractor shall be responsible for returning all public utilities to normal working order.

Locations of existing utilities are shown using available records. The Owner and the Engineer do not guarantee that the locations shown on the plans are accurate. Additional underground utilities or structures may be encountered. No additional payment will be made due to unknown or inaccurately located utilities. The Contractor shall notify Miss Dig and Utility Companies for utility locations before starting any earth moving operations.

The Contractor shall coordinate daily construction activities with that of utility companies which may be relocating some of their facilities as required by the project. No claim for additional compensation will be allowed based on delays caused by utility relocations.

Cost for complying with this specification shall be included in major items of work in the proposal. Therefore, no additional payment for these items shall be made.

## 20. UTILITY POLES

When necessary, the Contractor shall shore and brace utility poles that interfere with construction. Shoring and bracing shall be such that sinking or excessive tilting does not take place. All relocation or removing and replacing of power poles, light poles and telephone poles shall be done in accordance with Utility Owners Standards and all expenses shall be paid for by the Contractor. All arrangements for relocations with the Utility Company Owners shall be done by the Contractor at least 72 hours prior to need for relocations.

## 21. TELEPHONE

An emergency telephone system (listing of number) shall be set up and given to the Engineer and Owner so that the Contractor may be immediately notified of any unsafe conditions or emergencies encountered during times that the Contractor is not working on the project.

The Contractor shall provide a local number and a local employee so that he may be contacted at any time (including weekends and holidays) 24 hours a day.

## 22. EXISTING PRIVATE FACILITIES

Existing wells, septic tank, tile field, lawn sprinklers or other facilities disturbed or

damaged by the Contractor shall be repaired and restored to working condition before the end of that working day. Under no circumstances will such interruptions be extended overnight. The Contractor shall take necessary precautions not to allow any discharge from the above to enter any lake, stream or canal along the line of work. Costs for repairs or temporary service caused by the Contractor shall be at his own expense and no claims for extra work will be allowed.

All precautions necessary shall be taken to ensure no damage occurs to homes, including basements.

### 23. MAILBOXES

The Contractor shall temporarily relocate mailboxes interfering with construction so that mail service is not interrupted. Mailboxes shall be replaced in a condition, elevation and location equal to that existing prior to construction in accordance with U.S. Post Office requirements. Costs are incidental.

### 24. MATERIAL TESTING

The Owner reserves the right to sample and test any of the materials required for the proposed construction, either before or after delivery to the project and to reject any material represented by any sample which fails to comply with the minimum requirements specified.

The Contractor shall furnish all materials reasonably required for sample testing and analysis necessary for the testing of materials as required by these specifications.

The cost of the above testing shall be paid for by the Owner. If any pipe fails to meet the specified requirements, all pipe represented by the sample shall be rejected unless the Contractor can demonstrate through additional tests, at his own expense, that the remainder of the pipe is satisfactory.

As a minimum requirement, the following shall be submitted to the Engineer by the Contractor (at no extra cost to the Owner).

A. Gravels: A gradation analysis.

### 25. COORDINATION

The Contractor shall coordinate construction with the Owner and Engineer. Contractor shall attend periodic coordination meetings scheduled by the Engineer as necessary.

### 26. RECORD PLANS

The Contractor shall maintain a set of record drawings throughout the project. The Contractor shall make the drawings available to the Owner and Engineer in a timely manner upon request. A set of record drawings shall be submitted to the Engineer at the



completion of the project per the requirements detailed in section 1 of the City's Standard Specifications.

## 27. LAWN RESTORATION

This item includes all work necessary to return the area of construction operations to its original or better condition, paid by the square yard.

Initial restoration (rough grading, temporary aggregate if necessary, removal of excess excavated material and debris) shall be done each day to the extent necessary to allow the movement of local traffic and permit access to all properties for emergency vehicles. Maintenance of streets, drives, sidewalks, etc. shall be the responsibility of the Contractor (including dust control, grading, stabilization, etc.) until the restoration is complete and has been accepted by the Engineer.

Restoration of each street or section of utility line shall follow the construction in a timely fashion so as to minimize inconvenience to the adjacent property owners and the general public. The manner in which this restoration is done by the Contractor will be a determining factor in the approval by the Engineer of staking requests and partial payment requests

### A. Underground Sprinkling Equipment

Underground sprinkling lines, valves & heads, and water system curb stops and boxes are specifically excluded from the pay items. The Contractor shall take the necessary precautions to preserve this equipment during construction. Any underground sprinkling equipment disturbed by the Contractor shall be replaced at the Contractor's expense.

All underground sprinkling equipment shall be replaced in a timely fashion so as to minimize damage to the lawn areas. The Contractor will be responsible for any lawn damage caused by delayed replacement of the sprinkling equipment.

### B. Fences

Fences, which are removed for construction, shall be replaced with equal or better type and size. The cost of removing and replacing the fences shall be considered part of the major items of work found in the Proposal unless otherwise specified

### C. Ornamental Shrubbery and Bushes

Ornamental shrubbery and bushes that are removed during construction shall be replaced in kind and size in a vigorous growing condition. Replacement costs shall be considered part of the major items of work found in the Proposal unless otherwise specified. All shrubs and bushes replaced shall be insured by a one-(1) year warranty commencing from the date of installation.

### D. Turf Restoration

All areas of established turf shall be replaced as nearly as possible to their original or better condition. The cost shall be considered part of the major items of work found

in the Proposal.

- Topsoil  
Topsoil shall be placed at a minimum depth of four (4) inches over all areas disturbed by the Contractor's operations. The subgrade shall be graded to conform to the adjacent contours and shall be approved by the Engineer before placing topsoil. The topsoil shall then be placed in accordance with Section 816 of the MDOT 2012 Standard Specifications for Construction.

The soil shall be dark, organic natural surface soil, exclusive of muck or peat, suitable for the establishment of grass or other vegetable growth.

- Fertilizer  
After the topsoil has been placed, it shall be fertilized with a starter fertilizer at the rate of two (2) pounds per 1,000 square feet, in proportions of 16% nitrogen, 32% phosphoric acid, and 3% potash, or as directed by the Engineer. Fertilizer shall be applied just before the placing of the seed to retain its full benefit before unfavorable weather can cause deterioration.

- Seeding  
All previously seeded lawn areas shall be reseeded with Class A seed. Other areas disturbed by the Contractor's operations shall be seeded with Roadside seed. Temporary seed shall be placed for erosion control or temporary soil stabilization of stockpile areas. Seed mixtures, application rates, and methods shall be in accordance with Section 816 of the MDOT 2012 Standard Specifications for Construction.

Seasonal limitations on seeding in Section 816 of the MDOT 2012 Standard Specifications for Construction are waived. The Contractor shall repeat the seeding procedure as often as necessary to produce a close stand of weed-free grass

- Mulching  
All seeded areas shall be mulched immediately following the seeding. Mulching shall be applied to all newly seeded areas at a rate of two (2) tons per acre in accordance with the requirements of Section 816 of the MDOT 2012 Standard Specifications for Construction, or as directed by the Engineer. Separate loose straw mulch is prohibited on residential lawn areas
- Hydro Application  
All fertilizing, seeding and mulching shall be applied by an approved Hydro seeding and mulching process unless separate applications as heretofore described are approved by the Engineer.

- Erosion Control

All erosion control measures shall be installed and maintained in accordance with the Soil Erosion and Sedimentation Control plan and permit. Unless otherwise specified, mulch blanket and high velocity blanket shall be placed in accordance with Section 816 of the MDOT 2012 Standard Specifications for Construction.

- Sod

Sod shall be placed only where directed by the Engineer or as noted on the drawings or specifications.

All sod shall be nursery grown, conforming to MDOT requirements for Class A. Sod shall be approved by the Engineer before placing and shall be placed in accordance with the requirements of Section 816 of the MDOT 2012 Standard Specifications for Construction. The base on which the sod is to be laid shall consist of a minimum of four (4) inches of topsoil placed, watered and fertilized in the same manner required for seeding

## 28. LARGE TAP

Contractor shall provide all labor, materials, and equipment to install and perform the live tap per the City of Kalamazoo Standard Specifications for Water Main and Service Installation. This work includes excavation, dewatering, cleaning the main, disinfection, installing the tapping saddle and valve, hydrostatic testing, tapping the main, and backfill. This work may also include exposing the main at the location specified and backfilling the excavation, paid for separately. The Contractor shall place the tap as shown on the plans or as directed by the Engineer or Authorized Representative. Payment shall be measured for each tap installed based on the unit pricing for the size of the tap.

## 29. PS 22 VAULT REMOVAL

This item consists of all labor, materials, and equipment to remove the vault at Pump Station 22 to 6-inches below existing grade and associated work not covered by other pay items. After the Water Main, inch, Cut and Caps are complete, the 6-inch piping downstream of the valve shall be entirely removed. The vault lid shall be removed including portions of the vault walls, if needed, for the vault to be removed to 6-inches below existing grade. The vault shall be filled in the Class II Sand, compacted in 12-inch lifts. Finally, the area shall receive Lawn Restoration, paid for under its own pay item.

## 30. PAVEMENT REMOVAL AND REPLACEMENT

This work consists of removing and replacing HMA, concrete, masonry, and other common pavement material, except sand and gravel, regardless of thickness,

reinforcement and overlays.

The materials shall be HMA 13A, Modified; HMA 36A, Modified; Concrete, Grade P1; and Concrete S2. The pavement shall be removed to an existing joint or sawed joint. Saw cut pavement full depth in a straight neat line as directed by the Engineer. Do not use a crane and ball pavement breaker. Do not disturb remaining pavement. Assume ownership of removed materials and dispose of according to MDOT 2012 Standard Specifications for Construction subsection 205.03P.

After completion of the utility work, replace subgrade, subbase, and aggregate base in accordance with Michigan Department of Transportation Standard Plan for utility trenches R-83-Series. Replace sidewalk, driveway, and pavement matching existing materials. The completed work, as described, will be measured and paid for at the contract unit price using the following pay items:

Sidewalk Remove & Replace  
Road or Driveway Remove & Replace COK (Exhibit A)

The limits of the construction will be established at the discretion of the Engineer. Payment shall be based on the saw cut limits. The unit price includes all labor, equipment, and materials to saw cut, remove, haul, dispose of the pavement. All other material removal and replacement shall be included with other contract items.

### 31. PAYMENT

Payment shall be made for the proposal items only. All of the work specified above and indicated on the drawings shall be considered included in the unit prices shown on the proposal.

Definitions of abbreviations for measurement/payment:

LF	=	Lineal Foot
EA	=	Each
VF	=	Vertical Foot
LS	=	Lump Sum
CY	=	Cubic Yard
SY	=	Square Yard
SF	=	Square Foot
TON	=	Tonnage

**CITY OF KALAMAZOO  
DEPARTMENT OF  
PUBLIC SERVICES**

**WATER RESOURCES DIVISION**



**PUBLIC SERVICES DEPARTMENT**

WATER RESOURCES DIVISION  
415 STOCKBRIDGE AVE.  
KALAMAZOO, MICHIGAN 49001-2898  
PHONE 269-337-8601  
FAX 269-337-8533

**Standard Specifications for  
Water Main and Service Installation  
2021**



## WATER MAIN AND WATER SERVICES

### PART 1 GENERAL

#### 1.01 SCOPE

- A. This Section includes furnishing and installing water main systems.
- B. Reconnection of proposed water main and/or water service connections to existing water main and/or water service constructions shall be in conformance with requirements of this Section.
- C. This Section shall include furnishing, excavating, installing, testing, disinfecting, and backfilling all required water main pipe, water service pipes, water main appurtenances, water service, and other work incidental to the water main and/or water service installation unless specifically included under other Items.
- D. This work shall also consist of providing as-constructed plans of the completed work.

#### 1.02 SUBMITTALS

- A. Submittals shall be the responsibility of the Contractor:
  - 1. Shop Drawings for Review:
    - a. Manufacturer's Shop Drawings indicating physical dimensions, and joint details for each size, type, and class of pipe, fittings and specials furnished for the project.
  - 2. Information for the Record:
    - a. Manufacturer's certification indicating that the pipe and joints meet specifications for each production run for each size, type, and class of pipe furnished. The Engineer may request test results to verify certification. Certification documents shall be according to the Source Quality Control of this Section.
    - b. Manufacturer's installation instructions.
    - c. The laboratory shall submit test certifications of pipe ordered tested under "Field Quality Control," of this Section.
  - 3. Engineer may request additional Shop Drawings or Information for the Record as required.
  - 4. **Requests for approved equals must be submitted to the Engineer for review a minimum of two (2) weeks prior to bid.**

#### 1.03 AS CONSTRUCTED RECORD

- A. During construction the contractor shall be required to keep current a set of "as constructed" drawings. Before final payment shall be made, the contractor shall submit for approval to the City of Kalamazoo the complete set of as constructed drawings. Each set of "as constructed" drawings shall be labeled "As Constructed", dated, and contain at a minimum the following information (additional information may be required by the City of Kalamazoo):
  - 1. Note distance between all fittings (Center to Center of Fittings).
  - 2. Note Hydrant to valve, valve to main distances (Center to Center of Fittings).
  - 3. Note the type of bend used, (# of degrees), and the Direction of Bend: (Up or down), (N-S-E-W).

4. Note lengths and locations of restrained joints.
5. Details and profiles of special field situations that relate to the water distribution system shall be included.
6. Dimensional information locating each water distribution system component to real world features, such as property lines, right-of-way lines, and centerlines of roads.
7. On all cul-de-sacs with no center island, measure bends and hydrants to center of cul-de-sac. On all cul-de-sacs with a center island, measure bends and hydrants to center of the roadway.
8. When fittings/hydrants are installed as proposed, please circle the proposed listing.
9. All hydrants shall be noted as to whether or not drip valve plugs were installed.
10. When installing 12 inch or larger valves, (Butterfly Valves), indicate which side of the main the operating nut was placed, as well as gear box style with number of turns to close.
11. The contractor shall complete the service card information including a sketch of the water service installation with dimensions and location of the curb box.
12. Contractor shall GPS all valves, hydrants, fittings, as well a minimum every 3 lengths of pipe for straight runs. DWG files shall be provided to the Engineer upon completion of the project. GPS accuracy shall be subfoot.
13. **All as-built record drawings shall be completed and turned in to the Engineer within 2 weeks from completion of the installation.**

#### 1.04 CONTRACT WORK

- A. Prior to the start of construction, the City of Kalamazoo shall be given the opportunity to provide construction services for any and all portions of the water main construction. The City of Kalamazoo shall submit an estimated cost to perform the work or will issue a bill based on time and material costs. A separate contract with the City of Kalamazoo will be needed for work to be performed by the City of Kalamazoo.
  1. City of Kalamazoo shall perform all water main taps in the water system, unless otherwise directed by the Engineer.
- B. The City of Kalamazoo Department of Public Services must approve the Contractor who will perform water main installation. A reference list of at least five (5) Type 1 supply water main projects completed by the Contractor shall be submitted in support of the Contractor's qualifications. The Department of Public Services maintains a list of Contractors approved for water main installation and can be contacted to receive a current copy of that list.
- C. The Contractor (when hired by the City) or Developer (when the Contractor is hired to perform work by the Developer), shall provide a written statement of warranty (Warranty Bond) for a period of 2 years from the date of **final acceptance** for water main work or **after meter is installed** for water service work. Warranty work shall cover any necessary cost to repair water main or appurtenance leaks and water main or appurtenance leak damage at no cost to the City of Kalamazoo. Final acceptance on all water main and appurtenance work shall not occur until all items have been inspected by the Engineer, passed all required testing, as well as receipt and approval of all as built documents. Additionally, final acceptance on a water service will only be given **once the water meter is installed**.
  1. Water service or water main warranty work shall be completed either a prequalified contractor under the inspection of the City of Kalamazoo, or by City of Kalamazoo field service crews. All warranty work shall be paid for by the Developer or the Contractor.
- D. The Contractor is responsible for field locating all work which has not yet received final acceptance by the City of Kalamazoo. All damage to work that has not received final acceptance is the responsibility of the Contractor.

## PART 2 PRODUCTS

All Products shall be supplied new from the manufacturer and certified new from the supplier. No second hand or salvaged material shall be allowed. All products shall be **“Buy American”** unless otherwise specified in this section.

### 2.01 DUCTILE IRON

#### A. Ductile Iron (DI) Pipe Specifications:

1. Ductile Iron Pipe shall be manufactured in accordance with American National Standards Institute (ANSI) and American Water Works Association (AWWA) ANSI/AWWA C150/A21.50 and C151/A21.51. Pipe shall be minimum thickness Class 52 pipe. Flanged pipe shall be manufactured in accordance with ANSI/AWWA C 115/A21.15. Pipe through concrete floors or foundations shall be minimum thickness Class 53 pipe.
  - a. Water pipe must be lined with a standard thickness cement mortar lining sealed with a bituminous seal coat in accordance with ANSI/AWWA C104/A21.4, unless otherwise required. The outside of the pipe must be coated with the standard bituminous seal and each length of pipe must be marked with the following information
    - 1) Metal thickness class.
    - 2) Net weight of the pipe without lining.
    - 3) The nominal size.
    - 4) The manufacturer's identifying symbol.
  - b. Underground pipe shall be push on or mechanical joints and above ground pipe shall be flanged joints with gaskets meeting the requirements of ANSI/AWWA C111/A21.11. Nitrile or fluoroelastomer gaskets shall must be used as indicated on the plans and in locations of known or suspected soil or groundwater contamination as necessary. Gaskets provided will be specified based on the type of contamination that is encountered. Each joint shall contain serrated silicon bronze electrical continuity wedges as directed by the Engineer or authorized representative. 4 to 6 inch pipe shall use 2 wedges, 8 to 12 inch pipe shall use 3 wedges, and 16 inch and above shall use 4 wedges.
  - c. Pipe used in conjunction with Horizontal Directional Drilling operations shall be Flex-Ring or TR FLEX joints.

#### B. Restrained Joints

1. Restrained joints shall meet the requirements of ANSI/AWWA C111/A21.11, and AWWA/ANSI C110/A21.10 or ANSI/AWWA C153/A21.53.
2. Mechanical restrained joints shall be EBAA Iron Megalug series 1100, Romac Romagrip, Ford Series 1400, or approved equal.
  - a. Restraint devices for nominal pipe sizes 4 inch through 54 inch shall consist of multiple gripping wedges incorporated into a follower gland meeting the applicable requirements of ANSI/AWWA C110/A21.10.
  - b. The devices shall have a working pressure rating of 350 psi for 4 to 16 inch, 250 psi for 18 to 48 inch and 200 psi for the 54 inch size. Ratings are for water pressure and must include a minimum safety factor of 2 to 1 in all sizes.



- c. Gland body, wedges and wedge actuating components shall be cast from grade 65-45-12 ductile iron material in accordance with ASTM A536.
  - d. Ductile iron gripping wedges shall be heat treated within a range of 370 to 470 BHN.
  - e. Three (3) test bars shall be incrementally poured per production shift as per Underwriter's Laboratory (U.L.) specifications and ASTM A536. Testing for tensile, yield and elongation shall be done in accordance with ASTM E8.
  - f. Chemical and nodularity tests shall be performed as recommended by the Ductile Iron Society, on a per ladle basis.
  - g. All components shall be manufacture and assembled in the United States.
  - h. Coating for restraint devices shall consist of the following:
    - 1) All wedge assemblies and related parts shall be processed through a phosphate wash, rinse and drying operation prior to coating application. The coating shall consist of a minimum of two coats of liquid thermoset epoxy coating with heat cure to follow each coat.
    - 2) All casting bodies shall be surface pretreated with a phosphate wash, rinse and sealer before drying. The coating shall be electrostatically applied and heat cured. The coating shall be a polyester based powder to provide corrosion, impact and UV resistance.
    - 3) The coating system shall be MEGA-BOND by EBAA Iron, Inc. or approved equal.
3. Push on restrained joint shall be field locking gasket or Flex Ring style as manufactured by US Pipe, McWane, American USA, or approved equal. Field locking or Flex Ring gasket shall match appropriately to the manufacturer of the pipe used.
4. Use of threaded rods or thrust blocks as a restrained joint shall not be permitted, unless approved by the Engineer.
5. Restrained flange adapters shall be EBAA Iron Megaflange series 2100 or approved equal.
- a. Restrained flange adapters shall be made of ductile iron conforming to ASTM A536 and have flange bolt circles that are compatible with ANSI/AWWA C110/A21.10 (125#/Class 150 Bolt Pattern).
  - b. Restraint for flange adapter shall consist of plurality of individual actuated gripping wedges to maximize restraint capability. Torque limiting actuating screws shall be used to insure proper initial set of gripping wedges.
  - c. The flange adapters shall be capable of deflection during assembly or permit lengths of pipe to be field cut to allow a minimum of 0.6 inch gap between the end of the pipe and the mating flange without affecting the integrity of the seal.
  - d. All internal surfaces of the gasket ring (wetted parts) shall be lined with a minimum of 15 mils of fusion bonded epoxy conforming to the applicable requirements of ANSI/AWWA C213. The coating shall meet ANSI/NSF-61. Exterior surfaces of the gasket ring shall be coated with a minimum of 6 mils of fusion bonded epoxy conforming to the applicable requirements of ANSI/AWWA C116/A21.16.
  - e. Restraint Ring coated with MEGA-Bond Restraint Coating System.

C. Ductile Iron Pipe Fittings

1. Fittings, plugs, and gaskets must meet the requirements of ANSI/AWWA C111/A21.11, and AWWA/ANSI C110/A21.10 or ANSI/AWWA C153/A21.53. Cement mortar linings for fittings must meet the requirements of ANSI/AWWA C104/A21.4.
2. Mechanical joints shall be EBAA Iron Megalug series 1100, Romac Romagrip, or approved equal.
3. Restrained flange adapters shall be EBAA Iron Megaflange series 2100 or approved equal.

2.02 Ductile Iron Valves

- A. All underground valves in sizes from 4 inches to 10 inches shall be reduced wall, resilient-seated gate valves for water supply service meeting the requirements of AWWA C 515. Valves shall be American Flow Control Series 2500, Clow model 2638, or EJ Flowmaster Series resilient seated gate valve, Mechanical joint with rubber gaskets (per AWWA/ANSI C 111/A21.11), ductile iron body, stainless steel stem, mechanical joint restraint, and ¾ inch tee head bolts. Valves shall open right (clockwise) and be equipped with standard AWWA operating nut. Nut shall be color coded red. Valves shall have a working pressure rating of 250 psi or greater.
  1. In lieu of a mechanical joint restraint, American Flow Control Series 2500 valves may be equipped with ALPHA joints.
- B. All underground valves 12 inches and larger shall be rubber-seated butterfly valves meeting the requirements of AWWA C 504. Valves shall be Pratt Groundhog Butterfly Valves, by Henry Pratt Company, Clow, M&H, or Kennedy model 4500, mechanical joint with rubber gaskets (per AWWA/ANSI C 111/A21.11), ductile iron body, mechanical joint restraint, and ¾ inch tee head bolts. Valves shall open right (clockwise) and be equipped with standard AWWA operating nut. Nut shall be color coded red. Valves shall have a working pressure rating of 250 psi or greater.
- C. All above ground or in pits/vaults valves between 3 inches and 10 inches shall be rubber seated gate valves meeting the requirements of AWWA C515. Valves shall be American Flow Control Series 2500 Resilient Wedge Gate Valve, Clow model 2638, EJ Flowmaster Series, or approved equal with flanged joint with rubber gaskets (per AWWA/ANSI C 111/A21.11), ductile iron body, stainless steel bolts, nuts and washers, stainless steel stem, and be equipped with a hand wheel to operate. Valves shall have a working pressure rating of 150 psi or greater.
- D. All above ground or in pits/vaults valves 12 inches and larger shall be rubber seated butterfly valves meeting the requirements of AWWA C504. Valves shall be by Henry Pratt Company, Clow, M&H, or Kennedy, flanged joint with rubber gaskets (per AWWA/ANSI C 111/A21.11), ductile iron body, and ¾ inch stainless steel bolts, washers and nuts. Valves shall open right (clockwise) and be equipped with standard wheel to operate. Valves shall have a working pressure rating of 150 psi or greater.
- E. All underground valves in sizes from 4 inches to 16 inches used in combination with a tapping saddle shall be reduced wall, resilient-seated gate valves for water supply service meeting the requirements of AWWA C 515. Valves shall be American Flow Control Series 2500, Clow model 2638, EJ Flowmaster Series with one flanged and one mechanical joint ends with rubber gaskets (per AWWA/ANSI C 111/A21.11), ductile iron body, stainless steel stem, mechanical joint restraint, and ¾ inch tee head bolts or approved equal. Valves shall open right (clockwise) and be equipped with standard AWWA operating nut. Nut shall be color coded red. Valves shall have a working pressure rating of 250 psi or greater.

- F. All valves used in conjunction with a fire service line shall be Mueller R-2361-6 Outside Screw and Yoke (O.S.&Y.) with sample tap or approved equal. The stem shall be type 304 stainless steel. Sample tap shall have a 4 ½ inch brass nipple, brass ball valve, and brass plug meeting NSF/ANSI Standard 61 requirements. Sample tap shall be ½ inch for 4 inch and smaller valves and ¾ inch for valves larger than 4 inch.
- G. All valves installed using the insertion style method shall be an all stainless steel body Resilient Wedge Gate Valve designed for permanent use in potable water systems. The design will allow the valve to be installed into an existing pressurized pipeline while maintaining constant pressure and service without system shutdown. No restraining devices, restraining fasteners, or transition gaskets shall be required for the installation or operation of the valve. Valves in sizes 4 inches to 12 inches shall be Hydra-Stop Insta-Valve 250 or approved equal. 16 inch valves shall be Hydra-stop Insta-Valve Plus 250 or approved equal.

## 2.03 HYDRANTS

- A. All fire hydrants shall be American Flow Control or EJ and shall meet the requirements of AWWA C502. Hydrants shall be provided as complete units including hydrant, hydrant marker, pipe, pipe fittings and valve meeting section 2.01, 2.03 and 2.04 requirements. Hydrants shall be supplied for a bury depth of 5.5 feet. The hydrant barrel shall be painted safety yellow by the manufacturer. Hydrant caps and operating nut shall be painted John Deere green by the manufacturer.
  - 1. American Flow Control hydrants shall be 5 ¼ inch Waterous Pacer Traffic Model WB67-250. Hydrants shall be supplied with a 16 inch upper standpipe length. The Hydrant will come equipped with a bronze upper valve washer. In lieu of a mechanical joint restraint, hydrants may be equipped with ALPHA joints.
  - 2. EJ hydrants shall be WaterMaster Model 5BR250 with snow barrel.
- B. Hydrants shall come equipped with a Carrol Drain. Drain piping shall be made of type 304 stainless steel. External port shall have removable cap for flushing hydrant. Carrol Drain assembly shall be constructed so that it is removable when replacement of assembly is necessary.
- C. Hydrants shall have two 2 ½ inch national standard hose connections, 7.5 threads per inch, OD of threads 3 1/16 inch and one 5 inch integral "STORZ" type nozzle connection. Hose nozzle cap nut, weather shield hydrant operating nut, Storz nozzle cap nut, and Carrol Drain cap nut shall be square 15/16 inch at bottom of nut tapered to 13/16 inch at top (Waterous reference #19). The hydrant mechanism shall be on a non-rising stem opening clockwise. Chains shall not be supplied with the hydrant caps.
- D. Hydrants shall be equipped drip valve, tapped for plug. The drip valve system shall be bronze. Draining system shall be positively activated by the main operating rod, meaning the drip valve will open when the hydrant is closed. Hydrant shall be provided with plug removed.
- E. Hydrants shall have a 6 inch shoe with mechanical joint connections in conformance to ANSI/AWWA C115/21.11.

## 2.04 FIRE HYDRANT MARKER

- A. The fire hydrant sign shall be installed on a galvanized 2 pound sign post.
- B. The fire hydrant sign shall be aluminum 8 inch x 18 inch (MDOT type III-A) with hydrant symbol and down arrow of a reflective material.
- C. Fire hydrant mounted marker whips shall be 4 feet x 3/8 inch solid pultrusion fiberglass shaft, with seven (7) 6 inch bands of E.G. reflective sheeting of alternating lime green and red color.

Marker shall have a single solid stainless steel spring with aluminum threaded insert, and use Zinc coated bolt & mounting hardware.

## 2.05 TAPPING SLEEVES

- A. Tapping sleeves for size on size taps or 12 inch and larger sleeves:
1. Model shall be American Flow Control series 2800-C, Tyler Union, Smith-Blair series 665, Romac style SST III, Ford style FTSS, Ford MJTS, or approved equal.
  2. Ductile Iron Tapping Sleeves.
    - a. Sleeves shall be of construction meeting ASTM A536. Side flange seals shall be O-ring type of round cross-sectional shape.
    - b. All sleeves to include the end joint accessories and split glands necessary to assemble sleeve to pipe.
    - c. Sleeve shall be coated with asphaltic varnish in compliance with NSF-61.
  3. Stainless Steel Tapping Sleeves.
    - a. Sleeves shall be 18-8 type 304 Stainless Steel in accordance with AWWA C223.
    - b. Bolts, nuts, and washers shall be 18-8 Type 304 Stainless Steel. Nuts shall be heavy hex, and coated to prevent galling.
- B. Tapping sleeves smaller than 12 inch which are not size on size:
1. Model shall be Smith-Blair series 665, Romac style SST III, Ford style FTSS, or approved equal.
  2. Sleeves shall be 18-8 type 304 Stainless Steel in accordance with AWWA C223.
  3. Bolts, nuts, and washers shall be 18-8 Type 304 Stainless Steel. Nuts shall be heavy hex, and coated to prevent galling.
- C. Line Stop Tapping Sleeves and appurtenances:
1. Model shall be Hydra-Stop HSF 250 Patriot or approved equal
  2. Body shall be type 304 Stainless Steel in accordance with AWWA C223.
  3. Blind Flange shall be Epoxy Coated Carbon Steel or type 304 Stainless Steel.
  4. Bolts, Nuts and Washers shall be type 304 Stainless Steel.
  5. Completion Plug shall be HSF 250 Push and Pin Style, made of reinforced composite polymer.
  6. Completion Plug O-ring shall be BUNA-N Rubber
  7. Completion Plug Pins shall be SAE Grade 8, Zinc coated to prevent corrosion
  8. Completion Pin Plug shall be type 304 Stainless Steel, coated to prevent galling.
  9. Flange O-Ring shall be BUNA-N Rubber.
- D. All gaskets shall be Nitrile in compliance with NSF-61.
- E. No special tools shall be required other than standard socket wrench.
- F. Flange end pilot dimensions to be in compliance with MSS-Sp-60.

## 2.06 AIR RELEASE VALVES

- A. Air Release Valves – All air release valves shall be manufactured per ANSI/AWWA C512-04. Cla-Val Series 36 Combination Air Valves, or approved equal. The valves shall be of the size listed in the plans.
1. The combination air valve shall combine the operating features of both an air and vacuum valve and an air release valve in one housing. The air and vacuum valve portion shall automatically exhaust large quantities of air during the filling of the pipeline and automatically allow air to reenter the pipeline when the internal pressure of the pipeline approaches a negative value due to column separation, draining of the pipeline, or other emergency. The air release valve portion shall automatically release small amounts of air from the pipeline while it is under pressure.
  2. The inlet and outlet of the valve shall have the same cross section area. The float shall be guided by a stainless steel guide shaft and seat drip tight against a synthetic rubber seal. 4 inch and larger valves shall have dual guided shafts of hexagonal cross section and a protective discharge hood.
  3. The float shall be of all stainless steel construction and capable of withstanding maximum system surge pressure without failure. The body and cover shall be concentrically located and of ductile iron and the valve internal parts shall be stainless steel or Buna-N rubber.
  4. All 1 inch and 2 inch valves shall be NPT. All valves 4 inch and larger shall be flanged.
- B. Vent piping shall be 2 inch diameter, with copper piping below grade and galvanized piping above grade.
- C. Air vent screens shall be black PVC, with NPT threaded to match the size of the connection pipe. Screen shall be one-piece 304 Stainless, mesh size 100. Silver reflective tape shall be placed on the vent pipe.
- D. An air release valve sign shall be installed on a galvanized 2 pound sign post.
- E. The valve sign shall be aluminum 8 inch x 18 inch (MDOT type III-A) with valve symbol and down arrow of a reflective material.

## 2.07 REPAIR SLEEVES

- A. All repair sleeves shall be certified NSF/ANSI 61-G and 372, and be in accordance with AWWA C230. Sleeves without service tap shall be Smith – Blair model 226, PowerSeal model 3121, or approved equal. Sleeves with service tap shall be Smith – Blair model 238, PowerSeal model 3131, or approved equal.
- B. Sleeves shall use Type 304 Stainless Steel hardware in accordance with ASTM A193/A194. Sleeves shall have conductivity feature.
- C. The repair sleeves shall be of the full circle type designed to repair a fully broken (completely separated) pipe and shall be rated for a working pressure of not less than 150 psi. Repair sleeves 12 inches or under in size will have a single joint.
- D. The length of the sleeves shall not be less than 7 ½ inches. Sleeves shall have no less than three (3) guide bolts of the minimum specified length. Sleeves of longer length shall have an additional guide bolt for every two (2) inches of additional band length.
- E. Each sleeve shall consist of a sealing gasket, a non-magnetic stainless steel band with contact buttons protruding through specially prepared gaskets, clamp lugs, bolts and nuts.
- F. No welding will be permitted in the manufacture of stainless steel repair sleeves except for the addition of the tap to repair sleeve.

- G. The lugs shall not be deformed in the process of attachments to the band during assembly or during removal in the field.
- H. The gasket shall be natural rubber, nitrile or approved equal and shall be of the tapered overlap design to give a pressure tight fit on the pipe surface to form a leak tight, permanent seal when the repair sleeve is installed. The gasket shall have a grid pattern to conform pipe surface irregularities.
- I. The gasket shall have a stainless steel bridge plate flush mounted and securely bonded into the gasket during the molding of the gasket.

#### 2.08 POLYETHYLENE ENCASEMENT

- A. Polyethylene encasement must be manufactured using 8 mil thick virgin polyethylene in accordance with ANSI/AWWA C105/A21.10. Provide the tube size recommended by the manufacturer to protect the pipe and fitting sizes. Provide adhesive tape for the polyethylene tube as recommended by the manufacturer. Tape for repairing damage to the polyethylene must have a life expectancy equal to or greater than the life expectancy of the polyethylene.

#### 2.09 STEEL BLOW-OFF PIPE

- A. Steel pipe shall be hot dipped galvanized meeting the requirements of ASTM A53.

#### 2.10 WATER SERVICES AND APPURTENANCES

##### A. Copper Service Lines

- 1. Copper pipe shall be used for service lines which are  $\frac{3}{4}$  inch, 1  $\frac{1}{4}$  inch and 2-inch. All copper services shall conform to AWWA C800. Water service pipe shall be copper meeting the requirements of ASTM B88, type K.
- 2. All appurtenances on copper service lines shall be flare copper connections. Other connections may be used in lieu of flare copper connections if approved by the Engineer prior to installation.

- B. All water service appurtenances shall meet the requirements of AWWA C800 and be from The Ford Meter Box Company, Inc., A.Y. McDonald Mfg. Co., or as approved by the Engineer. All water service appurtenances for 2 inch and smaller are as follows:

##### 1. $\frac{3}{4}$ inch services:

- a. Corporation Stop  $\frac{3}{4}$  inch – FB600-3-NL or AY McDonald 74701B NL (3/4 inch)
- b. Service Saddle – Smith-Blair 311(4 to 12 inch water main), Smith-Blair 313 (16 to 24 inch water main), Romac 101U(4 to 12 inch water main), Romac 202SSU (16 to 24 inch water main), Ford F101(4 to 12 inch water main), or Ford F202(16 to 24 inch water main).
- c. Curb Stop (for use when reducing a 1  $\frac{1}{4}$  inch street service to  $\frac{3}{4}$  inch yard service) – Ford B21-555-NL, C18-35-NL, and C28-33-NL
- d. Curb Stop (when using  $\frac{3}{4}$  inch street service) – Ford B22-333-NL or AY McDonald 76100 NL ( $\frac{3}{4}$  inch)
- e. Brass Fittings – All brass fittings such as tees, elbows, caps, nipples and similar items shall be manufactured in the U.S.A.
- f. Couplings – Ford C22-33-NL or AY McDonald 74758 NL ( $\frac{3}{4}$  inch)

##### 2. 1 $\frac{1}{4}$ inch services:

- a. Corporation Stop – Ford FB600-45-NL or AY McDonald 74701B NL (1 x 1  $\frac{1}{4}$  inch)

- b. Service Saddle – Smith-Blair 311(4 to 12 inch water main), Smith-Blair 313 (16 to 24 inch water main), Romac 101U(4 to 12 inch water main), Romac 202SSU (16 to 24 inch water main), Ford F101(4 to 12 inch water main), or Ford F202(16 to 24 inch water main).
  - c. Curb Stop – Ford B22-555-NL or AY McDonald 76100 NL (1 ¼ inch)
  - d. Brass Fittings – All brass fittings such as tees, elbows, caps, nipples and similar items shall be manufactured in the U.S.A.
  - e. Couplings – Ford C22-55-NL or AY McDonald 74758 NL (1 ¼ inch)
3. 2 inch services:
- a. Tapping Valve – Ford B11-777-NL
  - b. Service Saddle – Smith-Blair 313, Romac 202S, or Ford F202
  - c. Brass Fittings – All brass fittings such as tees, elbows, caps, nipples and similar items shall be manufactured in the U.S.A.
  - d. Couplings – Ford C44-77-NL
4. Water meters – All water meters shall be Neptune Water Meters. They shall be supplied and installed by the City of Kalamazoo.
- C. All water service appurtenances larger than 2 inch shall be in accordance with section 2.01.
- D. All multiple meter settings with more than two meters excluding the fire meter shall use a fabricated meter manifold. Fabricated manifold shall be manufactured as follows:
- 1. Water manifold shall be made using 304 Schedule 40 Stainless Steel pipe.
  - 2. Inlet and outlets shall be threaded or welded flange. End cap shall be welded flange with a blind flange for future additions.
- E. Conduit used as sleeves shall be schedule 40 PVC or approved by Engineer.

## 2.11 METER SETTINGS

- A. Interior meter settings shall use components from the following manufactures.
- 1. 1 inch meter – Ford KV23-454W-NL Angle Valve, Ford C38-44-2-625-NL, Brass Nipple, Apollo 94ALF-105-01A Ball Valve or approved equal
  - 2. 1½ inch and 2 inch meter – Ford FV13-777W-NL Angle Valve, Ford CF35-66NL (1 ½ inch), Ford CF 35-77-NL (2 inch), Brass Nipple, Watts LFFBV-3C Ball valve or approved equal.
  - 3. 3 inch and larger- rubber seated gate valves meeting the requirements of AWWA C515. Valves shall be American Series 2500 Resilient Wedge Gate Valve with hand wheel by American or equal flanged joint with rubber gaskets (per AWWA/ANSI C 111/A21.11), and be equipped with a hand wheel to operate, Hymax 874-56-03008812 (3 inch), 874-56-04010812 (4 inch), 874-56-06016312 (6 inch), or 874-56-08021712 (8 inch) Flange Adaptor, and flange to plain end ductile or type 304 stainless steel spool piece.
- B. Exterior meter settings shall use components from the following manufactures.
- 1. 5/8 inch meter – Ford V81-22-33-NL
  - 2. ¾ inch meter – Ford V83-22-33-NL
  - 3. 1 inch meter – Ford V84-22-55-NL Copper setter

4. 1 ½ inch and 2 inch meter – Watts LFFBV-3C Ball Valve or approved equal. Ford CF-77-1-937-NL Meter Flange, Ford C28-77-NL Coupler, and Brass Nipple.
5. 3 inch and larger – All above ground or in pits/vaults valves 3 inches and larger shall be rubber seated gate valves meeting the requirements of AWWA C515. Valves shall be American Series 2500 Resilient Wedge Gate Valve with hand wheel by American or equal flanged joint with rubber gaskets (per AWWA/ANSI C111/A21.11), and be equipped with a hand wheel to operate, Hymax 874-56-03008812 (3 inch), 874-56-04010812 (4 inch), 874-56-06016312 (6 inch), or 874-56-08021712 (8 inch) Flange Adaptor, and flange to plain end ductile or type 304 stainless steel spool piece.

#### 2.12 FIRE SERVICE APPURTENANCES

- A. All fire service appurtenances shall meet the requirements of AWWA/ANSI C110/A21.10, AWWA C115, and be from the following manufacturers.
  1. Double Check Valve Detector Assembly – Zurn Wilkins Model 350DA or 350ADA with meter setting, AMES Colt LFC300 with meter setting, or approved equal. The City of Kalamazoo will supply the 5/8 inch water meter.
  2. Reduced Pressure Zone Assembly – When using a RPZ in lieu of double check valve for a backflow device, a Zurn Wilkins Model 375DA or 375ADA with meter setting, AMES Colt LFC500 with meter setting, or approved equal shall be required. The City of Kalamazoo will supply the 5/8 inch water meter.

#### 2.13 METER BOXES AND VAULTS

- A. All Meter Boxes, Meter Vaults and components shall be from the following manufactures.
  1. Box – Hancor MP NL1 24 0008 - 24 inch x 48 inch or ADS24X48MP 24 inchx48 inch white corrugated meter pit or Engineer approved equal.
  2. Vault – Precast concrete meter vault shall have a 3 inch minimum wall thickness and size shall be depended on number of meters and meter size. The wall shall have steps that are equally spaced 12 inches apart. Meter vault shop drawings shall be submitted to the Engineer and approved for each installation.
  3. Meter Pit Cover – Vestal 32-497, 32-055, 32-104, and 32-046 or approved equal.
  4. Meter Vault Cover – Ford MC-24HH-MB-T

#### 2.14 VALVE BOXES AND VAULTS

- A. Curb Stop Boxes for 1 ¼ inch Service – Bingham & Taylor Fig. No. 4901-B, 94-F with 2 ½” New Style Flush Fit Cover or approved equal. Cover shall be inscribed with the word “water”.
  1. Curb Stop Box extensions shall be cast iron and manufactured by Bingham & Taylor, capable of being mounted directly to the curb stop box.
- B. Gate Valve Box or 2 inch Service Box – the valve box shall be of adjustable length screw type. The valve box shall be a malleable iron casting conforming to subsection 908.03 of the 2012 Michigan Department of Transportation *Standard Specifications for Construction*. This valve box shall either be a two or three piece screw type and the cover shall be inscribed with the word “water.” Valve box 8550 Series (two piece) or 8560 Series (three piece) manufactured by EJ, 4905 size no. 22 manufactured by Bingham & Taylor, or approved equal.
  1. Gate Valve Box extensions shall be cast iron and manufactured by EJ or Bingham & Taylor, capable of being mounted directly to the gate valve box.
- C. Valve Vaults for Insta-Valves – Valve vaults used in conjunction with Insta-Valves shall be constructed with materials as detailed in WA-8-A of the City of Kalamazoo Standard Plans.



They shall be of the diameter specified and in accordance with subsection 823.02 of the Michigan Department of Transportation *Standard Specifications for Construction* for Gate Wells.

- D. Valve Vaults for Air Release Valves – Valve vaults used in conjunction with Air Release Valves shall be constructed with materials as detailed in the latest WA-4-Series or WA-5-Series of the City of Kalamazoo Standard Plans. They shall be of the diameter specified and in accordance with subsection 823.02 of the Michigan Department of Transportation *Standard Specifications for Construction* for Gate Wells.

#### 2.15 BACKFILL MATERIALS

- A. Use materials meeting the requirements of section 902 of the 2012 Michigan Department of Transportation *Standard Specifications for Construction*.

#### 2.16 BELL JOINT LEAK CLAMP

- A. Bell Joint Leak Clamps shall be Smith-Blair Model 274, Ford Meter Box FBC or MJSC style, or approved equal.
  - 1. The bell spigot ring, section connector, and range spacer shall be ductile iron 80-55-06 in accordance with ASTM 536. Fusion bonded epoxy finish shall meet application methods per AWWA C213. Spigot ring design shall be interlocking to allow ease of installation without interrupting the flow of the pipe. The bolt head pocket shall be integral for one wrench installation.
  - 2. Gasket shall be Nitrile Buna-N per ASTM D2000, and certified to NSF/ANSI 61-G & 372.
  - 3. Restraint Rods and Nuts shall be Type 304 Stainless Steel. Restraint Rod shall have rolled threads, and Nut shall be fluoropolymer coated to prevent galling.
- B. Bell encapsulating couplings shall be Ford Meter Box MJBE style.
  - 1. The coupling shall be designed to fully encapsulate the pipe bell. The coupling shall be of split mechanical joint design with independent end seal and side seal gaskets.
  - 2. All welded components shall be constructed with ASTM A 36 carbon steel.
  - 3. The end seal and side seal gaskets shall be virgin NBR formulated for water service. The gaskets shall not require field trimming, cutting or modification.
  - 4. The end seal compression ring shall be manufactured with ductile iron per ASTM A 526 Grade 65-45-12 or ASTM A 36 carbon steel.
  - 5. The coupling shall be coated to an average of 12 mills thickness with a fusion-bonded epoxy that is NSF 61 listed and meeting application methods of AWWA C213.

#### 2.17 COUPLINGS

- A. Wide range couplings shall be Romac Alpha or approved equal.
  - 1. All cast components shall be ductile iron, meeting or exceeding ASTM A 536, grade 65-45-12
  - 2. Grippers shall be ductile iron, meeting or exceeding ASTM A 536, grade 65-45-12.
  - 3. Gaskets shall be SBR compounded for water service per ASTM D2000 and meet NSF61 classification.
  - 4. Bolts and nuts shall be 304 stainless steel.
  - 5. Body shall be epoxy coated, and NSF61 Certified.

2.18 STRUCTURE CASTINGS

- A. All 24 inch structure covers shall be a malleable iron casting conforming to subsection 908.03 of the 2012 Michigan Department of Transportation *Standard Specifications for Construction*. The structure cover shall be series 1040 manufactured by EJ, inscribed with the word "Water".

2.19 STEEL CASING PIPE AND APPURTENANCES

- A. Steel casing pipe shall meet the requirements in accordance with subsection 909.05.D of the 2012 Michigan Department of Transportation *Standard Specifications for Construction* with the exceptions listed below:

- 1. For steel casing pipe jacked under a railroad, replace in its entirety the entry for 30 inch nominal size listed in Table 909-18 with the following:

**Nominal OD and Wall Thickness in Inches Jacked in Place Steel Pipe**

Nominal Size	Nominal Outside Diameter	Wall Thickness
30	30.000	0.406(a)
<ul style="list-style-type: none"> <li>a. Coated or cathodically protected (0.469 inch minimum if uncoated and unprotected)</li> </ul>		

- 2. Steel casing must have a minimum yield strength of 35,000 pounds per square inch (psi) and be in accordance with ASTM A53, Type E or S, Grade A or B and be designed for Cooper E80 loading requirements. In all cases, the allowable jacking strength capacity of the casing pipe shall be capable of withstanding the maximum jacking forces imposed by the operation.

- B. Stainless steel band spacer shall be Advance Products & Systems model SSIM or approved equal. The bands shall be constructed of circular stainless steel bands, which bolt together forming a shell around the carrier pipe. The spacers shall be designed with runners to support the carrier within the casing and maintain a minimum clearance of 1.00 inches between the casing inside diameter (ID) and the spacer outside diameter (OD). The spacers shall contain four modular runners – two on each half. Stainless steel bolts, nuts and washers shall be supplied with the casing spacers.

The band shall be manufacture of 8 inch wide 14-guage T-304 stainless steel. Abrasion resistant runners, having a minimum length of 7 inches and a minimum width of 1 inch, shall be attached to each band to minimize friction between the casing pipe and the carrier pipe as it is installed. Runner material shall be of glass filled polymer with compression strength of 33,000 psi, flexural strength of 40,000 psi, and tensile strength of 27,000 psi. The ends of thall runners shall be beveled to facilitate installation over rough weld beads or the welded ends of misaligned or deformed casing pipe.

Interior surfaces of the circular stainless steel band shall be lined with PVC, or EPDM alternate, having a minimum thickness of .090 inches with a harness of Durometer "A" 85-90.

Recommended position of the spacers is one placed not more than one foot from each end of the casing and pipe joint. Subsequent spacers shall be placed every 6-8 feet apart thereafter.

- C. Casing end seal shall be Advance Products & Systems model AC or approved equal. Pull-on casing end seals shall be manufactured of 1/8 inch thick neoprene rubber assuring excellent chemical resistance and resiliency. End seals must be effectively used in the temperature range of -20 degrees to 190 degrees Fahrenheit. End seals shall include ½ inch wide T304 stainless steel bandings with 100% nonmagnetic worm gear mechanism. End seals shall be seamless, have vulcanized edges, and can be pulled on at the time of construction.

## PART 3 EXECUTION

### 3.01 CONSTRUCTION

- A. The plans show the locations of existing utilities in accordance with available data. If the work requires precise information on the location of existing utilities, the Contractor will expose utilities shown on the plans to determine the actual locations.

Do not disturb or cut into existing in-service water mains. If the operation of valves in existing water mains is required, notify the City of Kalamazoo a minimum of 3 working days in advance. Coordinate scheduling of water main connections with the City of Kalamazoo. Secure the Engineer's or authorized representative's approval of the schedule before beginning the work.

The City of Kalamazoo will open or close in service valves and provide on-site inspections for all water main and water service installations. The City of Kalamazoo will perform this work for an estimated time and material charge. The cost of opening and closing valves and on-site inspection will need a separate contract with the City of Kalamazoo prior to start of work. This does not apply to work being contracted by the City of Kalamazoo.

Minimize the out of service time for existing water mains. Make connections at night, on Sundays, or on holidays, as conditions require or as approved by the City of Kalamazoo. Minimize interference with the water supply if abandoning existing water mains and incorporating new water mains into the water system.

No trees or permanent structures shall be placed within 10 feet of the centerline of the water main or service line.

### 3.02 TRENCH EXCAVATION

- A. Excavate water main trenches to the lines and grades shown on the plans in accordance with modifications approved by the Engineer, or authorized representative, or to meet or bypass existing utility structures. Excavate trenches to the depths shown on the plans to provide 5 feet of cover from top of water main to the final grade. Excavate trenches to the widths shown on Michigan Department of Transportation Standard Plan R-83 Series.
- B. Excavate the bottom of the trench to the required grade to allow 6 inches of bedding for the pipe. Do not block under the pipe.
- C. Maintain trenches for water mains free of ground or surface water by pumping or as otherwise approved by the Engineer or authorized representative
- D. Install, and later remove, temporary timber bracing, as required to prevent movement or damage to new or existing water mains or adjacent utilities.
- E. During backfilling, carefully remove supports for sheeted and braced excavations to prevent earth banks or adjacent streets from collapsing.
- F. The Contractor may leave sheeting and bracing in place during backfilling and remove after completing backfilling operations. The Contractor may leave sheeting and bracing in place, if approved by the Engineer and the Contractor cuts it off 5 feet below the ground surface.

### 3.03 DISPOSAL

- A. Dispose of waste material as specified in section 205 of the 2012 Michigan Department of Transportation *Standard Specifications for Construction*.

### 3.04 LAYING OF THE PIPE

- A. Install the pipe joint restraint system in accordance with the manufacturer's recommendations, or as directed by the Engineer. Assemble the pipe in the trench. If deflections at joints are required by changes in grade, alignment, or to plumb valve stems, ensure deflections of bell and spigot joints and mechanical fitting joints do not exceed three-quarters of the maximum deflection recommended by the joint manufacturer or that allowed by AWWA C600, whichever is less. Do not store or leave tools or other objects in the pipe.
- B. Provide restrained joints as indicated on the plans. No tie rods or thrust blocks shall be allowed unless approved by the Engineer or authorized representative.
- C. Proper actuation of the gripping wedges of the mechanical joint restraint shall be ensured with torque limiting twist off nuts.
- D. The Contractor shall provide a written statement of warranty (Warranty Bond) for a period of 2 years from the date of **final acceptance (after meter is installed)**. Warranty work shall cover any necessary cost to repair water main or appurtenance leaks and water main or appurtenance leak damage at no cost to the City of Kalamazoo. Final acceptance will only be given **once the water service meter is installed**.
- E. Pipe shall be laid with bell ends facing the direction of laying, unless otherwise directed by the Engineer or authorized representative. When pipe is laid on a grade of 10 percent or greater, the laying shall start at the bottom and proceed upward with the bell ends of the pipe upgrade.
- F. Install silicon bronze wedges between all push-on joint pipes to allow for underground location and thawing of pipeline. 4 to 6 inch pipe shall use 2 wedges, 8 to 12 inch pipe shall use 3 wedges, and 16 inch and above shall use 4 wedges at each pipe joint.
- G. Pipe shall be restrained in accordance with Table 3.1.

**Table 3.1 Pipe Thrust Restraint Table**

NON-POLYWRAPPED PIPE								
Pipe Size (Inches)	90° Bend	45° Bend	22.5° Bend	11.25° Bend	Tee*	Reducer (One Size)	Reducer (Two Sizes)	Dead End
4	44	18	9	5	42	-	-	42
6	62	26	13	7	59	31	-	59
8	82	34	17	9	78	33	56	78
10	100	42	20	10	94	32	58	94
12	119	50	24	12	110	33	59	110
16	157	65	32	16	143	61	85	143
20	195	81	39	20	173	61	109	173
24	233	97	47	23	204	61	111	204
30	288	120	58	29	246	86	134	246
POLYWRAPPED PIPE								
Pipe Size (Inches)	90° Bend	45° Bend	22.5° Bend	11.25° Bend	Tee*	Reducer (One Size)	Reducer (Two Sizes)	Dead End
4	62	26	13	7	60	-	-	60
6	88	37	18	9	84	44	-	84
8	117	49	24	12	111	47	80	111
10	142	59	29	14	133	45	82	133
12	170	71	34	17	158	47	84	158
16	224	93	45	23	203	87	121	203
20	278	116	56	28	247	87	155	247
24	332	138	66	33	291	87	159	291
30	411	171	82	41	351	123	191	351
* Length of restraint for branch; use the size of the branch Consult Engineer for scenarios not included in table.								

**3.05 INSTALLATION OF PIPE INVOLVING HORIZONTAL DIRECTIONAL DRILLING**

- A. Horizontal direction drilling (HDD) is a method of trenchless construction using a surface launched steerable drill tool controlled from a mobile drilling frame, and includes a field power unit, drilling fluid mixing system, and mobile spoils extraction system. The work generally consists of three phases:
1. Drilling a pilot hole from the surface or pit at a starting point to an exit pit at the surface beyond the obstacle or area that is to be avoided.
  2. Reaming the pilot hole to make it large enough for the pipeline to be installed.
  3. Pipeline is pulled into place. During the pipe pulling operation, drilling fluid (a bentonite, water, and polymer solution) is injected to stabilize the hole, remove cuttings, and lubricate the pipe.
- B. Coordination

1. Drilling operations shall not interfere with, interrupt or endanger surface features or surface activities.
2. When rock stratum, boulders, underground obstructions, or other soil conditions that impede the progress of drilling operation are encountered, the Contractor and Engineer shall review the situation and jointly determine the feasibility of continuing drilling operations, making adjustments or switching to an alternative construction method.
3. The contractor shall familiarize themselves with the geologic characterization of the soil stratum at the proposed drilling path. The Contractor shall be responsible for informing the Engineer of any changes that are required in the directional drilling procedure due to geologic conditions.
4. Launching and recovery pits shall be as small as practical. Dewatering of pits and excavations shall be done in accordance with the City of Kalamazoo Standard Specifications. When groundwater is encountered, the Contractor shall provide a dewatering system of sufficient capacity to keep any excavation free from water until the backfill operation is in progress. Dewatering shall be performed in a manner that removal of soil particles is held to a minimum. Water from the dewatering system shall be desilted before discharge. Methods of dewatering and desilting, including all costs shall be the Contractor's responsibility and are included in the Horizontal Directional Drilling Water Main pay item.
5. Utilities shown on the plans are approximate. In areas where there is a potential conflict, the Contractor shall dig up and verify the locations and elevations of the utilities at no additional expense to the City. The Contractor shall assume full responsibility for the protection fall utilities, structures and their foundations which may be affected by the work.
6. Before beginning the drilling process, the Engineer shall stake the proposed drill path.

C. Drill Path Survey

1. The Drill path shall be walked in the presence of the Engineer and the Contractor with the guidance system that shall be used for each segment of drill path. The contractor shall locate and record any surface and subsurface magnetic variations or abnormalities and all points of interference, as well as verifying all utility locations and corresponding utility maps. Should any discrepancies arise between utility maps, field locations and guidance system findings, the Contractor shall clarify all discrepancies prior to beginning drilling operations. The drill path survey shall be performed no earlier than two days prior to commencing drilling operations. Provide the Engineer 48-hour notice of drill path survey.

D. Equipment

1. The drilling equipment shall be capable of placing the pipe within the planned line and grade without inverted slopes.
2. The drilling equipment shall be capable of pulling product pipe from either the downstream or upstream pit locations. The equipment must be adequately sized for the application.
3. The guide system shall have the capability of measuring inclination, roll and azimuth. The guidance system shall have an independent means to ensure the accuracy of the installation. The Contractor shall demonstrate a viable method to eliminate accumulated error due to the inclinometer (pitch or accelerometer). The guidance

system shall be capable of generating a plot of borehole survey for the purpose of a record drawing. The guidance system shall meet the following specifications:

Inclination:	Accuracy	+0.05
	Range	+90
	Repeatability	+0.02
Roll:	Accuracy	+0.05
	Range	+90
Azimuth	Accuracy	+0.05
	Range	+90

4. Equipment setup requirements at the launch and recover locations shall be determined by the Contractor in accordance with the Plans and shall be submitted to the Engineer prior to commencement of drilling operations.

E. Pilot Hole Drilling

1. The entry angle of the pilot hole and the drilling process shall maintain a curvature that does not exceed the allowable bending radii of the carrier pipe per the manufacturer's recommendations.

F. The contractor shall follow the pipeline alignment as shown on the Plans, within the specification requirements. The location and depth of the drill head in relation to the profile and centerline of the alignment shall be determined at a maximum of ten-foot intervals. Acceptable tolerance shall be 0.5 feet variation from the centerline of the pipe in both vertical and horizontal directions (1-foot tolerance window).

G. In the event of difficulties at any time during drilling operation requiring the complete withdrawal from the tunnel, the Contractor shall either be allowed to withdraw and abandon the tunnel and begin a second attempt at a different location. The alternate locations shall be approved by the Engineer before the Contractor withdraws.

H. Access pits shall be at the beginning and end segments shown on the Plans. Intermittent pits shall be approved by the Engineer prior to proceeding with drilling operations. No intermittent access pits shall be allowed in Railroad Right of Ways.

I. Installing the Carrier Pipe:

1. After the pilot hole is completed, the Contractor shall install a swivel to the reamer and commence pullback operations.
2. Reaming diameter shall not exceed 1.5 times the diameter of the carrier pipe being installed.
3. The carrier pipe being pulled into the tunnel shall be protected and supported so that it moves freely and is not damaged by stones and debris on the ground during installation.
4. Pullback forces shall not exceed the allowable forces for the carrier pipe.

J. The Contractor shall allow sufficient lengths of carrier pipe to extend past the termination point to allow connections to adjacent pipe sections, tees, or fittings. Pulled pipe shall be allowed 24 hours of stabilization prior to making tie-ins. The length of extra carrier pipe shall be at the Contractor's discretion.

K. Field Inspection

1. All pipe sections, specials, and jointing materials shall be carefully examined for defects and no piece shall be laid that is known to be defective. Any defective piece discovered installed shall be removed and replaced with a sound one in a manner satisfactory to the Engineer at the Contractor's expense.
2. Defective material shall be marked with an "X" in pink paint and shall be removed from the job site.

L. Drilling Fluid Containment and Disposal Requirements

1. The contractor shall contain, handle, and dispose of drilling fluids in accordance with the following requirements:
  1. All drilling fluid and fluid additives shall be disclosed, and Material Safety Data Sheets (MSDS) shall be provided to the permit agency and the Engineer upon request.
  2. Excess drilling fluid shall be confined in a containment pit at the entry and exit location until recycled or removed from the site.
  3. Precautions shall be taken to ensure that drilling fluid does not enter the roadways, streams, municipal storm or sanitary sewer lines, and/or any other drainage system or body of water.
  4. When installing below railroads, vents shall be installed on either side of the railroad tracks to direct any excess drilling fluid to a containment area and to prevent unintended surfacing of drilling fluid within the Railroad Right of Way.
  5. Unintended surfacing of drilling fluid shall be contained at the point of discharge and recycled or removed from the site.
  6. Drilling fluids that are not recycled and reused shall be removed from the site and disposed at an approved disposal site.
  7. Drilling fluids shall be completely removed from the construction site prior to backfilling or restoring the site.

3.06 ABANDONING WATER MAINS

- A. Remove and dispose of abandoned pipe, gate boxes, or other appurtenances, as necessary for placement of a new water main at no additional cost to the City of Kalamazoo. Remove portions of gate boxes to at least 3 feet below the pavement surface under the road, and to at least 12 inches below the planned grade outside the road. If the Engineer determines abandoned mains may remain in place, cap the end of pipe with cap and megalug or as directed by the Engineer or authorized representative. If shown on the plans or directed by the Engineer or authorized representative, fill abandoned water mains with non-structural flowable fill.

3.07 VALVES

- A. Prior to installation, all valves shall be fully operated open and close to verify its functionality and number of turns. Set and join valves to the water mains as required for cleaning, laying, and jointing the required type of pipe, as shown on the plans. Install valves as required by the contract, or as approved by the Engineer. Place the valve stems plumb. Install valves to not bear on the pipe. Install anchor coupling with valves installed on tees or crosses, with swivel gland located on the valve side of the anchor coupling.
- B. When installing 12 inch and larger valves (Butterfly Valves), the operating nut shall be located on the side of the valve furthest from the centerline of the roadway, unless otherwise directed by the Engineer.



### 3.08 LIVE TAPS TO IN SERVICE WATER MAINS

- A. Prior to tapping of the main contractor shall disinfect all pipe, appurtenances, tapping machine with chlorinated water.
- B. Contractor shall install all necessary tapping appurtenances according to manufacturer's recommendation.
- C. Contractor shall use equipment which allows the tapping machine to rinse out metal shavings and tap water main per manufacturer's recommendations. No tap 4 inches or larger shall be allowed within 4 feet from any joint, fitting, or exiting tap regardless of location of tap. 1 ¼ inch taps located within 10 feet of previous tap shall be offset 15 degrees.
- D. Once tapping is complete Contractor shall disinfect all exposed water main and appurtenances with chlorinated water.

### 3.09 VALVE BOXES.

- A. Provide valve boxes that do not transmit shock or stress to the valve. Place valve boxes plumb over the operating nut of the valve, with the box cover flush with the pavement, or as approved by the Engineer or authorized representative. Provide firm support for valve boxes.
- B. Valve boxes shall be installed, centered and plumbed over the operating nut of the gate valve. The area around the valve box shall be back-filled with Granular Material Class II placed in layers not to exceed 12 inches, and thoroughly compacted to the required density. The Contractor shall take due care to prevent the box from shifting during backfilling operations. The tops of the valve boxes shall be flush with the established pavement or ground surface.

### 3.10 ADJUSTING OR RECONSTRUCTING WATER SHUT OFFS OR VALVE BOXES

- A. Adjust and reconstruct water shutoffs or valve boxes to the final grade or as approved by the Engineer or authorized representative. Replace shutoff or gate box materials damaged during adjustment or reconstruction, as determined by the Engineer, or authorized representative, at no additional cost to the City of Kalamazoo.

### 3.11 WATER SERVICES

- A. Water Services shall not be connected to the water main until approved by the Engineer or authorized representative.
  - 1. The standard size for all new services shall be 1 ¼ inch. The property owner/developer may request a larger size if needed.
  - 2. ¾ inch service materials may only be used when performing repairs or partial replacements of an existing ¾ inch service, or when replacing the yard service of a ¾ inch service. When replacing a complete street side service of a ¾ inch service, a new 1 ¼ inch tap will be completed, new 1 ¼ inch street service line installed, and reduced down at the curb shut off per section 2.10.
- B. Tap water main per section 3.08.
- C. When more than two meters excluding the fire meter are required to be set on a single service line, a fabricated meter manifold shall be installed.
- D. Water Services 2 inch and Smaller
  - 1. Construct services from the distribution main to the water meter. Lay services in a straight line perpendicular to the water main unless approved by the Engineer or authorized representative. Construct service with a continuous piece of copper from the corporation stop to the curb stop and curb stop to the water meter unless

approved by the Engineer or authorized representative. Services over 300 feet will require an exterior meter setting (meter pit).

2. All couplings shall be located as close to the water main as possible, but outside roadway unless approved by the Engineer.
3. The use of thread sealant shall be not be allowed on flare fittings.
4. No splices shall be allowed for 1 ¼ inch or smaller yard services 90 feet and shorter in length.
5. Tap and curb shut off locations shall be no closer than 5 feet to edge of driveways. If a service is required to be abandoned due to improper location, service shall be fully abandoned at the water main tap location and new service installed the developer's expense. Corporation stop shall be shut off, copper piping removed, and copper disc installed on the corporation stop.
6. If finish grade changes from plan grade after installation of service, curb shutoff shall be adjusted to 5 foot bury depth at the developer's expense.
7. When the street service is installed separately from the yard service a copper disk shall be installed on the yard side of the curb valve per the manufactures recommendations as approved by the Engineer or authorized representative.

E. Water Services Greater than 2 inch

1. For services entering a building with no basement, install the stand pipe flange 12 inch from the finished floor elevation and 6 to 12 inches away from any walls. Install the flange pipe so two bolt holes are parallel from each wall (two hole). For services entering a building with a basement or into a concrete vault, install the stand pipe flange 6 to 12 inches off the wall. Install the flange pipe so that two bolt holes are parallel to the floor, normal to the wall. For all services entering a building, the service line shall be located in room located on an outside wall of the building, with enough room to maintain the service.
2. Contractor shall complete installation of service prior to pressure testing and disinfection. The Contractor shall hydrostatic test the complete fire service from the nearest outside valve to first valve (OS&Y) before installing the fire check valve per section 3.22. Service shall be cleaned, flushed and tested per section 3.23. No connection shall be made to these services until after pressure test is complete and consecutive negative bacterial test results have been received in accordance with sections 3.22 and 3.23 of this specification, and the water main approved by the Engineer or authorized representative.
3. No adapter flange or grooved pipe joint shall be used on any portion of the service to be maintained by the City of Kalamazoo, with the exception of the meter side of an OS&Y fire service valve.
4. For service lines with multiple meter settings, a valve the same size as the incoming service line shall be installed prior to the tee or manifold. If one of the meter settings is for a fire service, the valve shall be an OS&Y valve in accordance with section 2.02.F.

F. Construct the service pipe with at least 5 feet of cover, unless Engineer or authorized representative requires additional depth.

G. Make all service connections, and transfers. Maintain and protect, at no additional cost, existing service connections requiring transfer, but not shown on the plans, until reconnection or disposal.

- H. If relocating a portion of water service, shut down the water service by method approved by the Engineer or authorized representative.
- I. Service lines entry points into the structure shall be sealed with hydraulic cement or mastic putty and oakum to prevent groundwater infiltration. For ductile iron pipe services, link seals should be used as the preferred method.
- J. FIRE SERVICES
  - 1. The Contractor shall notify the Engineer or authorized representative a minimum of 3 working days prior to flushing the fire service or testing the fire system capacity.
  - 2. All fire services shall have an OS&Y valve meeting the requirements of 2.02.F installed. The sample tap on the OS&Y Valve shall be installed on the downstream side of the valve.
- K. INTERIOR METER SETTINGS (PREFERED)
  - 1. Interior valve and meter inlet connection shall be installed by the Contractor in accordance with the Engineer, or authorized representative's recommendations and final approval.
  - 2. The meter setting shall be located in a heated portion of the building. The meter setting shall not be located in a crawl space, above electrical appliance, or near an electrical panel. A clear and unobstructed access to the meter of not less than 24 inches by 24 inches shall be provided.
    - a. 1 ¼ meter settings must be placed in basements. Meter setting shall be placed in the front of the building facing the street or within three feet of the front on the side unless otherwise approved by the Engineer or authorized representative. Water Services shall not be placed under footings. If service enters house under the porch and the porch footing extends below water service, a 2 inch PVC sleeve will be required.
    - b. A ½ inch schedule 40 PVC conduit, or larger, shall be installed from the meter setting to the remote reading point. There shall be no more than 75 feet of conduit between pull boxes. There shall be no more than four (4) 90-degree bends between pull boxes. All pull boxes must be installed no more than 96 inches above the floor. Pull boxes shall not be installed in attics or crawl spaces.
  - 3. The City of Kalamazoo will install the meter, readout, readout wire, copper ground wire, outlet meter connection and valve.
- L. EXTERIOR METER SETTINGS
  - 1. Exterior meter settings shall be installed by the Contractor according to the Engineer's or authorized representative's recommendations, and in accordance with City of Kalamazoo Standard Plans. Meter settings will be required for services greater than 300 feet, slab on grade, crawl spaces, where minimum 5 foot bury depth cannot be maintained, and other reasons. Contractor shall verify proper meter location with the Engineer prior to construction.
  - 2. Meter boxes or vaults shall not be installed in any street, alley, parking area, driveway, or sidewalk. Major landscaping (shrubs, boulders, etc.) and structures (retaining walls, fences, buildings, etc.) shall not be placed within seven and a half (7.5) feet or trees shall not be planted within ten (10) feet of any meter box or vault, unless otherwise directed by the Engineer.

3. The ground surrounding meter boxes, pits and vaults shall slope away from the lid at a minimum grade of 2%
4. No plumbing or electrical connections will be allowed inside the meter box or vault, unless otherwise directed by the Engineer.
5. All tees, connections, and couplings shall be a minimum of five (5) feet downstream from the meter box or vault wall on the outlet side. Tees and connections shall not be installed between the curb stop and the meter setter or copper horn.
6. Meters shall be installed by the City of Kalamazoo upon inspection and acceptance of the meter setting.
7. Meter boxes shall be used for all 1 inch exterior meter settings. The Contractor shall install meter boxes to horizontal location and to final grade as determined by grade stakes. Meter boxes shall be installed 5 feet outside the right of way in private property. All work shall be in accordance with the current WS-8 of the City of Kalamazoo Standard Plans.
8. For services 1 ¼ inch and smaller, curb shutoffs shall be located in the right of way, centered in the curb lawn area, or as directed by the Engineer.
9. The Contractor shall install meter vaults for 1 ½ inch and larger meter settings.
10. Meters shall be installed by the City of Kalamazoo upon inspection and acceptance of the meter setting.

### 3.12 WATER MAINS, CUT AND PLUG

- A. All work related to water main, cut and plug shall be in accordance with section 3.06.A. If the plans show cutting and plugging water mains, arrange for the City of Kalamazoo to shut down the main. Remove the section of pipe and plug the water main as shown on the plans or as approved by the Engineer or authorized representative. Construct the required restraint as directed by the Engineer or authorized representative.

### 3.13 FIRE HYDRANTS

- A. Set fire hydrants at the locations shown on the plans and in accordance with City of Kalamazoo standard plans and manufacturer's recommendations or as coordinated with the City of Kalamazoo. When installed, the hydrant shall be located on the side of the water main furthest from the centerline of the roadway, unless otherwise directed by the Engineer. Equip the hydrant with auxiliary valves, as shown on the plans. Stand hydrants plumb, with side nozzles parallel to the curb, and with the pumper nozzle normal to the curb, unless otherwise directed by the Engineer. Place the nozzles at the height specified by the City of Kalamazoo.
- B. For all gate valves connected adjacent to a tee or hydrant, the anchor between the fitting or hydrant and the valve shall be a 6 inch by 13 inch swivel by solid adapter with swivel gland. The swivel gland shall be located on the hydrant side of the solid adapter.
- C. Install a valve box over hydrant valve in accordance with section 3.09.
- D. Hydrants shall have a protective cover placed over hydrants prior to backfilling to ensure the hydrant is not damaged. If hydrant is damaged, the contractor shall repair or replace the hydrant at no cost to the City.
- E. If site conditions are such that it is not desirable for hydrant drain into the surrounding soil (i.e. when hydrant has less than 10 feet of separation from a sewer, high ground water, impervious or contaminated soils, etc.), hydrant drip valve plug(s) shall be installed by the Contractor onsite. Final determination on drip valve plug installation shall be made by the

Engineer or his representative. As constructed records shall be noted whether or not the drip valve plug was installed.

### 3.14 FIRE HYDRANT MARKER

- A. The sign shall be located between the hydrant and curb and offset from the pumper nozzle, or as directed by the Engineer. The sign shall be placed 3 feet away from the hydrant. The sign shall be single sided or double sided as directed by the Engineer or authorized representative. The sign shall have an installed height to the bottom of the sign of 7 feet above the final grade in areas with sidewalk and 5 feet above the final grade in areas without sidewalk.
- B. A fire hydrant mounted whip may be installed in addition to fire hydrant sign if approved by the Engineer. Fire hydrant whip shall be mounted to the fire hydrant opposite the pumper nozzle in accordance with the manufacturer's specifications.

### 3.15 FIRE HYDRANT REMOVAL

- A. If the plans show removal of a fire hydrant, remove the entire hydrant assembly, including the following:
  - 1. Auxiliary gate valve and box, unless otherwise approved by the Engineer or authorized representative.
  - 2. Internal valve assembly;
  - 3. Top bonnet;
  - 4. Standpipe; and
  - 5. Hydrant inlet body, unless otherwise approved by the Engineer.
- B. If the City of Kalamazoo approves leaving the auxiliary gate valve and box in place, remove to at least 3 feet below the pavement surface under the road, or at least 12 inches below planned grade outside the road.
- C. Stockpile the removed material at a location accessible to the City of Kalamazoo. The City of Kalamazoo will maintain ownership of the hydrant, and will remove the assembly from the project site

### 3.16 RELOCATING FIRE HYDRANTS

- A. If the plans show relocating a hydrant, arrange for the City of Kalamazoo to shut down the hydrant auxiliary valve. Remove the hydrant and reinstall at the required location. Reconnect the hydrant to the water main by shutting down the main, tapping a new hydrant outlet, or using the existing outlet. Install piping as required. If the relocated hydrant does not pass testing the hydrant shall be replaced with new at no cost to the City of Kalamazoo.

### 3.17 MISCELLANEOUS FITTINGS

- A. Install the following at the locations shown on the plans and in accordance with good construction practices and manufactures recommendations:
  - 1. Elbows,
  - 2. Tees,
  - 3. Corporation stops,
  - 4. Blow offs,
  - 5. Pipe adapters,
  - 6. Pipe couplings,

7. Retaining glands, and
8. Other miscellaneous fittings.

### 3.18 AIR RELEASE VALVES AND VAULTS

- A. Construct air release valves and vaults in accordance with the current WA-4-Series and WA-5-Series of the City of Kalamazoo Standard Plans.
- B. When installing the air release valves in conjunction with new water main construction, the contractor shall use ductile iron fittings.
- C. When installing the air release vaults as a retrofit to existing water main, live taps may be performed as directed by the engineer.

### 3.19 BACKFILLING AND COMPACTING

- A. Backfill and compaction shall be in accordance with Michigan Department of Transportation Standard plan for utility trenches R-83-Series.
- B. Backfilling Under Existing Conduits – Where it is necessary to undercut or replace existing utility conduits and/or service lines, the excavation beneath such lines shall be backfilled the entire length with granular bedding material tamped in place in 6-inch layers to the required density. The granular bedding shall extend outward from the spring line of the conduit a distance of 2-feet on either side and thence downward at its natural slope.
- C. Backfilling with Excavated Material – Unless otherwise specified or directed, material excavated in connection with the work shall be used for backfilling and other filling purposes, if it meets all requirements given elsewhere in this specification.
- D. Backfill Immediately Following Inspection – All trenches and excavations shall be backfilled immediately after pipe is laid therein, unless otherwise directed by the Engineer or authorized representative. Under no circumstances shall water be permitted to rise in un-backfilled trenches after pipe has been placed.
- E. Service leads shall not be backfilled until the pipe ends are referenced and the Engineer or authorized representative has measured the pipe for payment.
- F. Backfilling around and over structures and pipes shall be carefully done by hand and tamped with suitable tools of approved weight to a point 1-foot above the top of pipe. Selected material or, where specified or ordered by the Engineer, special backfill material shall be used in this area. The material shall be placed in uniform layers not exceeding 6-inch in depth up each side. Each layer shall be placed, then carefully and uniformly tamped to the specified density so as to eliminate the possibility of lateral displacement of pipe or structure.
- G. Backfilling by Machinery – After the backfill has been placed and compacted around the boxes and pipe to a height of 1-foot above the top. The remainder of the trench may be backfilled by machine. The backfill material shall be deposited in horizontal layers and each layer shall be thoroughly compacted to the specified density by approved methods before a succeeding layer is placed. In no case will backfill material from a bucket be allowed to fall directly on a structure or pipe and in all cases the bucket must be lowered so that the shock of the falling material will not cause damage.

### 3.20 COMPACTION REQUIREMENTS

- A. Compact each layer to 95% (90% if outside the influence of the roadway) maximum density as tested by the Michigan Department of Transportation Density Testing and Inspection Manual.

### 3.21 COMPACTION TEST

- A. Trenches and excavation around structures shall be backfilled and consolidated in layers, as specified, to the existing ground surface. Compaction tests shall be performed on each layer immediately after compaction.
- B. Initial test series for each type of backfill material shall be continued until the method of consolidation employed has proven to attain the required compaction. Any change in the proven method of consolidations will require additional testing and field verification of compaction.
- C. Subgrade below pavements, curbs, sidewalks, and structures shall be consolidated as specified. Compaction tests shall be performed to verify specified consolidation.

3.22 HYDROSTATIC TESTING

- A. Perform hydrostatic testing of water mains in accordance with AWWA C600.
- B. Ensure City of Kalamazoo personnel witness pressure testing. Give the City of Kalamazoo personnel at least 1 full working day notice before testing.
- C. Provide the personnel, temporary timber bracing, plugs, test pumps, temporary connections to the Municipal water system, and any other required apparatus. Provide the water for hydrostatic testing if not available from the City of Kalamazoo. Water must be pumped from a measurable source in order to determine testing allowance water.
- D. Before applying test pressure, expel air from the pipe in increments of no greater than 1,000 feet. Pressure test each section of water main. If the Contractor chooses not to pressure test against an existing valve, a new valve may be installed at the expense of the Contractor.
- E. Pipe shall be pumped with water to a minimum test pressure of 150 pounds per square inch (psi) at the highest point of elevation to begin test. Test shall last for at least 2 hours, with a maximum drop of pressure of 5 psi. If the pressure drop is greater than 5 psi but less than 20 psi, a testing allowance water test shall be performed. Testing allowance water, as measured by the quantity of water pumped into the pipe to attain the pressure at which the test began must not exceed the testing allowance.
- F. Testing allowance water is determined using the following formula

$$L = \frac{SD\sqrt{P}}{148,000}$$

Where

- L= testing allowance water in gallons per hour
- S= length of pipe in feet
- D= actual pipe diameter in inches, and
- P= 150 psi

- G. If testing allowance water is above the allowable limit occurs during hydrostatic testing, remove backfill to expose pipe and repair the joints. Repeat testing after repairs are complete. If multiple leaks occur the contractor may be required to reinstall main at Contractors expense.
- H. Correct visible leaks regardless of the amount of leakage. Replace faulty pipes, fittings, gate valves, or other accessories disclosed by testing. Repeat the test until the pipes, fittings, gate valves, and other accessories meet the requirements.

### 3.23 DISINFECTION, FLUSHING, AND BACTERIOROLOGICAL TESTING

- A. Disinfect the water main in accordance with AWWA C651 and applicable Michigan Department of Environment, Great Lakes, and Energy (EGLE) regulations after successful hydrostatic testing.
- B. Disinfect and flush new, and portions of existing, water mains as required by the EGLE.
- C. Use blow offs, fire hydrants, or other means as shown on the plans or approved by the Engineer, or authorized representative, to flush water mains in accordance with AWWA C651, with a velocity of at least 3 feet per second. Provide hoses and other equipment and arrange a means of disposing of the water without damaging the work or adjacent property.
- D. Use the continuous feed method with chorine added simultaneously with the water. Add chlorine or liquid hypochlorite to meet the requirement of at least 25 milligrams per liter of chlorine. Slowly add the water to the main and allow it to stand for at least 24 hours. At the end of the 24-hour period, ensure the chlorine residual is a minimum of 10 milligrams per liter. If not met, re-chlorinate and flush the water main until a minimum 10 milligrams per liter residual remains after 24 hours.
- E. After completing disinfection, initially flush the water mains with water at a velocity of at least 3 feet per second to replace the entire volume of chlorinated water in the pipeline. After initial flushing, perform final flushing until the residual chlorine content meets the standard level for the water distribution system. The City of Kalamazoo may require a waiting period after flushing and before bacteriological sampling.
- F. Dispose of chlorinated water in accordance with applicable state and local requirements. If necessary, apply a reducing agent to the water to neutralize the chlorine and create a chlorine residual of no greater than 1 ppm. Dechlorination shall be in accordance with AWWA C655.
- G. After flushing, perform bacteriological testing in accordance with AWWA C651 and EGLE requirements. Test chlorine residuals before taking each bacteriological sample. Ensure the chlorine residual is less than 1.5 milligrams per liter before taking a bacteriological sample. The City of Kalamazoo will collect samples from each branch of pipe in the presence of the Engineer, or authorized representative, and contractor personnel. The City of Kalamazoo will be responsible for the transportation of the samples to a State of Michigan approved lab for testing. Two consecutive bacteriologically safe tests at 24-hour intervals for each section of pipe are required. Acceptable tests are negative for bacteria and as otherwise defined by AWWA C651 and EGLE regulations.
- H. If a bacteriological test fails, repeat disinfection, flushing, and testing.
- I. Pressure and chlorination taps shall be removed within one business day of passing tests, so main can be activated.

### 3.24 POLYETHYLENE ENCASEMENT

- A. Polyethylene encasement will be required for all ductile iron installations when the soil test evaluation is greater than or equal to 10 points based as indicated in AWWA/ANSI C105/A21.5 or as directed by the Engineer. Sampling of the soils is to be completed by the developer or municipality responsible for the installation.
- B. Install polyethylene encasement on water mains and fittings installed through concrete floor and foundations and as indicated on the plans in accordance with the manufacturer's installation instructions and AWWA/ANSI C105/A21.10. Appropriately sized polyethylene encasement shall be used so that there are no longitudinal splices. This may require using one or more size larger diameter encasement than the pipe installed.



- C. Polyethylene encasement shall be required for all installations when groundwater is detected in the utility trench.
- D. Polyethylene encasement shall be required for all directional drilling installations involving ductile iron pipe.

3.25 WATER INFRASTRUCTURE IN STEEL CASING

- A. Work shall be performed in accordance with section 401 of the Michigan Department of Transportation *Standard Specifications for Construction* and as detailed herein. In all cases, the Contractor shall submit a work plan detailing the following:
  - 1. Means and methods for bracing and shoring;
  - 2. Methods of maintaining and adjusting line and grade;
  - 3. Drilled/bored diameter;
  - 4. Drill hole stabilization procedures;
  - 5. Size and location of the auger head relative to the casing;
  - 6. Methods of dealing with cobbles/boulders and obstructions;
  - 7. Estimated jacking thrust required;
  - 8. Method of monitoring casing elevation;
  - 9. Thrust block design calculations;
  - 10. Record keeping system to document casing advance and jacking pressures;
  - 11. Grouting procedures;
  - 12. Temporary dewatering measures and;
  - 13. Mitigation procedures if sinkholes or settlement above the pipe occurs or excessive movement of the settlement monitors is observed.
- B. Minimum Allowable Depths.
  - 1. The minimum allowable depth of the Horizontal Auger Bore (HAB) installed casing pipe shall be in accordance with Table 3.2

<b>Table 3.2 Minimum Allowable Depths Table</b>	
<b>Location</b>	<b>Minimum Depth</b>
Base of Rail	6 Feet
Existing Ground	5 Feet
Roadway	5 Feet
Ditch Flowline	5 Feet

- C. Access Pits.
  - 1. Excavate jacking and receiving pits as necessary. Provide and install all sheeting, shoring, bracing and any other earth retention measures in accordance with section 704 of the Michigan Department of Transportation *Standard Specifications for Construction*. Provide site drainage and subsurface dewatering and other items associated with the operation as necessary to facilitate the proposed work.
- D. Lead Auger/Overcut Allowance.

1. A full-size auger section shall be used as the lead section of the casing. The auger shall not protrude from the leading edge of the casing. However, if soil conditions halt the movement of the casing, the auger shall be allowed to protrude not more than 1 inch in front of the casing during the boring operation. Overcut is the annular space between the excavated hole and the outside diameter of the casing pipe. The allowable overcut diameter is one inch greater than the casing pipe radius.
- E. Watertight joints.
1. Watertight joints are required to ensure the integrity of the road and railroad bed. Casing pipe shall be constructed to prevent water leakage or earth infiltration and must be certified free from any breaks or leaks throughout its entire length.
- F. Lubrication Fluids.
1. Lubrication fluids are specifically required for this method regardless of the soil conditions. Any deviations from the use of lubrication shall require prior approval for the Engineer. The Contractor shall install vents on either side of the casing pipe to prevent fracking during installation. These vents shall also be used as relief in case of a water main break. Lubrication fluids, consisting of a mixture of water and bentonite or bentonite/polymer, shall be used in the annular space between the casing being installed and the native soil to stabilize and lubricate the drill hole. Grease will not be allowed for use as lubrication for this purpose.
- G. Pipe Locating and Tracking.
1. One of the following tracking, locating, and guidance systems shall be used:
    - a. Waterline system.
    - b. Mechanical control head.
    - c. Electronic (inertial) control head.
    - d. Walkover system.
    - e. Laser guided tunnel attachment.
    - f. Laser guided pilot rod.
  2. The Contractor will be responsible for submitting their proposed pipe locating tracking method at the preconstruction meeting for approval.
- H. Settlement/Heaving Monitoring.
1. Settlement/Heaving monitoring shall be performed in a manner that will minimize the movement of the ground in front of, above, and surrounding the horizontal auger bore operation; and will minimize subsidence of the surface above and in the vicinity of the boring. The ground shall be supported in a manner to prevent loss of ground and keep the perimeter and face of the boring stable at all times, including during shutdown periods. A survey shall be performed one day prior to initiating this operation at each required monitoring location. A similar survey shall then be performed at each location, on a daily basis, until the permitted activity has been completed. All survey readings shall be recorded to the nearest one-hundredth (0.01) of a foot. Digital photographs of the pavement and rail conditions shall also be taken prior and after the pipe installation. Specific monitoring locations and requirements may also be provided for railway crossings.
- I. Ground Water Control.

1. Dewatering shall be conducted whenever there is a high ground water table level to prevent flooding and facilitate the operation. The water table elevation shall be maintained at least 1 foot below the bottom of the casing at all times. When needed, dewatering may be initiated prior to any excavation.
2. Minor water seepage or pockets of saturated soil may be effectively controlled through bailing or pumping. This control shall be accomplished without removing any adjacent soil that could weaken or undermine any access pit, its supports, or other nearby structures.
3. Larger volumes of ground water shall be controlled with one or more well points or with staged deep wells. Well points and staged deep well pumping systems shall be installed and operated without damage to property or structures, and without interference with the right of the public, owners of private property, pedestrians, vehicular traffic, or the work of other contractors. Any pumping methods used for dewatering and control of ground water and seepage shall have properly designated filters to ensure that the adjacent soil is not pumped along the water. Well diameter, well spacing and the pump's pumping rate shall provide adequate draw down of the water level. Wells shall be located to intercept ground water that otherwise would enter the access pit excavation and interfere with the work. Upon removal of a well, the hole shall be filled and grouted.
4. Existing storm sewers shall only be used to discharge water from the dewatering operation in accordance with a permit obtained from the appropriate storm sewer owner. Filters or sediment control devices shall be required to ensure that the existing system is not adversely affected by construction debris or sediment.

J. Casing End Seals/Bulkheads

1. Casing ends shall be enclosed using 1/8 inch thick synthetic rubber casing ends seals in accordance with section 2.19.C of this document. Ensure end seals are water tight and attach securely to the casing pipe and the carrier pipe (water main). Ensure end seals are acceptable to the Engineer.

K. Backfill Requirements.

1. Remove the pits and backfill the excavations as necessary with material meeting the standard specifications as approved by the Engineer.

L. Railroad Specific Requirements.

1. For Steel casing pipe jacked in place under a railroad, the following will apply in accordance with the current AREMA Manual;
  - a. When steel casing pipe is used, the joints must be fully closed by welding or mechanical means as approved by the Engineer.
  - b. Minimum cover over the casing must be at least 6.0 feet from the bottom of the railroad tie to the top of the casing pipe at its closest point.
  - c. Casing pipe must extend beyond the limits of the entire railroad right-of-way.
  - d. Jacking construction requirements must be in accordance with the current AREMA Manual, Chapter 1, Part 4.

3.26 INSTALLATION OF LINE STOPS AND INSERTION VALVES

- A. Line Stops and Insertion Valves shall be performed in the locations as detailed on the plans or as directed by the Engineer. Prior to installation of the line stop or insertion valve, coordinate the deactivation of the water main so that all customers have been given proper notification

of the shutdown. No work shall be performed without the Engineer or authorized representative present.

B. Excavate and expose the water main. Remove scale from the water main and make sure there are no flaws which would affect the seal with the saddle.

C. Line Stops

1. Install permanent line stop body on the pipeline and perform line stop according to manufacturer's instructions. Upon completion of the work associated with the line stop, reactivate the water main and install permanent blind flange on the line stop body. Ensure that all as built information is recorded and submitted as detailed in section 1.03.

D. Insertion Valves

1. Install Insertion Valve body on the pipeline and perform valve insertion according to manufacturer's instructions. Operate the valve to ensure that it is fully functional.

2. Construct valve vault as detailed in WA-8-A of the City of Kalamazoo Standard Plans. Ensure that all as built information is recorded and submitted as detailed in section 1.03.

### 3.27 FINAL RESTORATION

A. Contractor shall restore site to preconstruction condition or better, or as detailed on the plans.

B. Final grade shall be 5 feet above completed water main or water service line, unless otherwise approved by the Engineer. If final grade is changed greater than 6 inches from the approved plans, the Developer or Contractor shall raise or lower water main and water services so that they are maintained at 5 feet below final grade. All costs associated with this work shall be paid for by the Developer or Contractor.

PART 4 MEASUREMENT AND PAYMENT

4.01 PAY ITEMS

Measurement a payment may not apply if construction is not being funded with City of Kalamazoo funds. Please review signed construction contract for actual measurement and payment specifications.

<b>Pay Item</b>	<b>Pay Unit</b>
Water Main, DI __ inch, Tr Det __ .....	Foot
Water Main, DI __ inch, in Casing.....	Foot
Water Main, DI __ inch, HDD.....	Foot
Gate Valve and Box, __ inch,.....	Each
Butterfly Valve and Box, __ inch.....	Each
Polyethylene Encasement.....	Foot
Water Main, __ inch, Cut and Plug .....	Each
Fire Hydrant .....	Each
Hydrant, Rem .....	Each
Hydrant Relocate, Case __ .....	Each
Water Serv .....	Each
Water Serv, Long.....	Each
Water Serv, Conflict .....	Each
Water Serv, Yard .....	Each
Copper Tubing, Additional Length .....	Foot
Water Serv, 2 inch.....	Each
Water Serv, Conflict, 2 inch .....	Each
Copper Tubing, Additional Length, 2 inch .....	Foot

Steel Casing Pipe, \_\_\_inch, Jacked in Place.....Foot

4.02 MEASUREMENT OF PAY ITEMS

- A. Payment for Water Mains shall be measured based on the sizes and trench details required, along the centerline of the pipe, with no deductions for fittings. The unit price of Water Main, DI, includes the cost of the following:
  - 1. Excavation and backfill;
  - 2. Dewatering operations (trench and/or pipe);
  - 3. Provide temporary water system to maintain service during construction;
  - 4. Hydrostatic testing;
  - 5. Disinfecting and flushing the water main and bacteriological testing;
  - 6. All material, labor and equipment necessary to remedy an unsatisfactory hydrostatic test, including removing and replacing any backfill;
  - 7. Providing and installing fittings, gaskets, bracing or sheeting, blocking and miscellaneous items for installing pipe and reconnecting to the Municipal Water System;
  - 8. Preparing and providing as-constructed plans.
  
- D. The City of Kalamazoo may withhold payment and/or final acceptance until the City of Kalamazoo accepts the as-built plans.
  
- E. The cost of dewatering of trenches, pipe, or both associated with alterations to the Municipal Water System, is included in the unit price for relevant items of work.
  
- F. The cost of excavating, disposing of excess material, and providing, placing, and compacting the backfill, is included in the unit price for related items of work.
  
- G. The cost of removing or abandoning existing water mains, gate valve boxes, and other appurtenances to provide clearance for the proposed water main or roadway, is included in the unit price for relevant items of work.
  
- H. Payment for Gate Valves, Butterfly Valves, and Valve Boxes, shall be as follows:
  - 1. The unit prices of **Gate Valve and Box** and **Butterfly Valve and Box**, of the types and sizes required, include the cost of providing and installing the valve and valve box, complete and ready for use.
  
- I. Payment for water services 1 ¼ and smaller shall be as follows:
  - 1. **Water Serv** refers to services between the water main and the curb shut off no greater than 33 feet long. **Water Serv, Long** refers to services between the water main and the curb shut off greater than 33 feet long and up to 66 feet in length. **Water Serv, Yard** refers to the services between the curb shut off and the water meter setting, up to 25 feet in length. **Copper Tubing, Additional Length** refers to the additional copper tubing and work needed when services between the curb shut off and the water meter setting are over 25 feet in length, and when the length of the service between the center of the road and the curb shut off exceeds 66 feet. **Water Serv, Conflict** refers to relocating only a portion of a water service.
  
- J. Payment for water services 2 inches in size shall be as follows:
  - 1. **Water Serv, 2 inch** refers to the services between the water main and the water meter setting no greater than 58 feet in length. **Water Serv Conflict, 2 inch** refers to relocating only a portion of a 2 inch water service. **Copper Tubing, Additional length, 2 inch** refers to the additional copper tubing and work needed when services exceed 58

feet in length.

- K. Services with a diameter larger than 2 inches will be measured and paid for as water mains.
- L. The unit prices for **Water Serv, Water Serv, Long, Water Serv, Yard, Copper Tubing, Additional Length, Water Serv Conflict, Water Serv, 2 inch, Water Serv Conflict, 2 inch,** and **Copper Tubing, Additional Length, 2 inch**, include the cost of the following, unless otherwise accounted for in other pay items:
  - 1. Earth excavation;
  - 2. Removing pavement;
  - 3. Replacing pavement;
  - 4. Jacking and boring;
  - 5. Providing and installing type K copper tubing, service saddle, corporation stops, service stops, and service boxes;
  - 6. Disinfecting;
  - 7. Providing, placing, and compacting backfill;
  - 8. Slope Restoration to equal or better conditions; and
  - 9. Miscellaneous material, equipment, or operations.
- M. Payment for additional service connections, not shown on the plans, but maintained, protected, and reconnected or disposed of by the Contractor will be paid for as **Water Serv**, or **Water Serv, Long**.
- N. The pay item **Water Serv, Conflict** will apply only to portions of water services requiring relocation due to direct conflict with utilities, other items of work, or as otherwise approved by the City of Kalamazoo. Payment for all other relocations requiring replacement of corporation or service stops will be paid for as Water Serv or Water Serv, Long.
- O. Payment for **Water Main, \_\_inch, Cut and Plug** includes the cost of cutting the existing water main, providing and placing the required plug, and thrust blocks.
- P. Payment for **Fire Hydrant** includes the cost of providing and installing the hydrant, hydrant valve, valve box, and all pieces between the valve and hydrant, including the coarse gravel and concrete base, fire hydrant marker at the locations shown on the plans in a ready-for-use condition unless noted otherwise.
- Q. Payment for **Hydrant, Rem** includes the cost of breaking down the auxiliary gate valve, gate box, the hydrant assembly, backfilling, and plugging the opening in the existing main.
- R. Payment for **Hydrant, Relocate, Case \_\_** (of the case required), includes the cost of vertically adjusting the relocated hydrant to final grade and the following:
  - 1. Case 1 includes the cost of removing the hydrant, extending the existing hydrant lead from the gate valve, reinstalling the hydrant in a ready-for-use condition, adjusting the existing gate box and hydrant to final grade, and providing and installing sleeves, fittings, and joint restraints.
  - 2. Case 2 includes the cost of removing the existing hydrant, gate valve and box, and reinstalling the hydrant and gate valve in a ready-for-use condition, adjusting the existing gate box and hydrant to final grade, and providing and installing the cutting-in-sleeve, pipe coupling, tee, elbow, and joint restraints.
- S. Payment for **Steel Casing Pipe, \_\_inch, Jacked in Place** of the size required will be paid for by the length installed. The unit price for **Steel Casing Pipe, Jacked in Place** includes the cost of excavating the pits, providing and installing sheeting, bracing, and any other safety devices, providing jacking equipment: drainage and dewatering; bulkheading and sealing the casing, providing and installing vents, grouting the annular space between the casing and native soil and any other items associated with the operation.

- T. Payment for **Water Main, DI, \_\_inch, in Casing**, of the size required will be paid for by the length installed. The unit price for **Water Main, DI \_\_inch, in Casing** shall include the cost for furnishing and installing the water main and casing spacers inside the casing.
- U. Payment for **Water Main, DI, \_\_inch, HDD**, of the size required will be paid for by the length installed. The unit price shall include the cost of all equipment and materials, excavation and backfill, dewatering operations (trench, pit or pipe), temporary water system to maintain service during construction, hydrostatic testing, disinfecting and flushing the water mains, and bacteriological testing, all materials, labor and equipment necessary to remedy and unsatisfactory hydrostatic test, including removing and replacing any backfill, providing and install all, gaskets, bracing or sheeting, blocking and miscellaneous items for installing pipe of the required size and material and reconnecting to the water system as shown on the plans.

END OF SECTION



This page was intentionally left blank.

WA-1-D

ITEM	QTY.	#	DESCRIPTION
1	1	39887	6" HYDRANT W/CARROLL DRAIN
2	2	70000	CONNECTING PIECE (13")
3	4	33801	6" GASKET (MJ)
4	1	96696	6" GATE VALVE (MJ)
5	1	08550	VALVE BOX BOTTOM
6	1	08520	VALVE BOX TOP SECTION
7	1	08500	VALVE BOX RING CASTING
8	1	08490	VALVE BOX COVER
9	1	91440	6" TEE MJ
10	1	91525	8" X 6" TEE MJ W/MEGALUGS
11	1	91750	10" X 6" TEE MJ W/MEGALUGS
12	1	91825	12" X 6" TEE MJ W/MEGALUGS
13	1	91909	16" X 6" TEE MJ W/MEGALUGS
14	1	91940	20" X 6" TEE MJ W/MEGALUGS

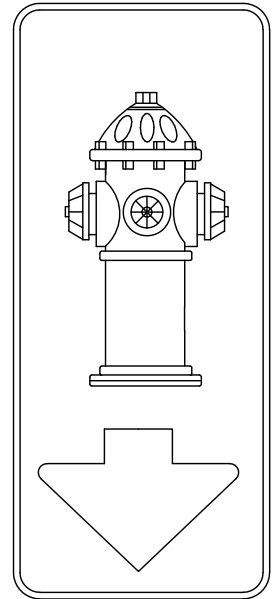

TYPICAL HYDRANT SIGN

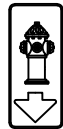

DOUBLE SIDED HYDRANT SIGN

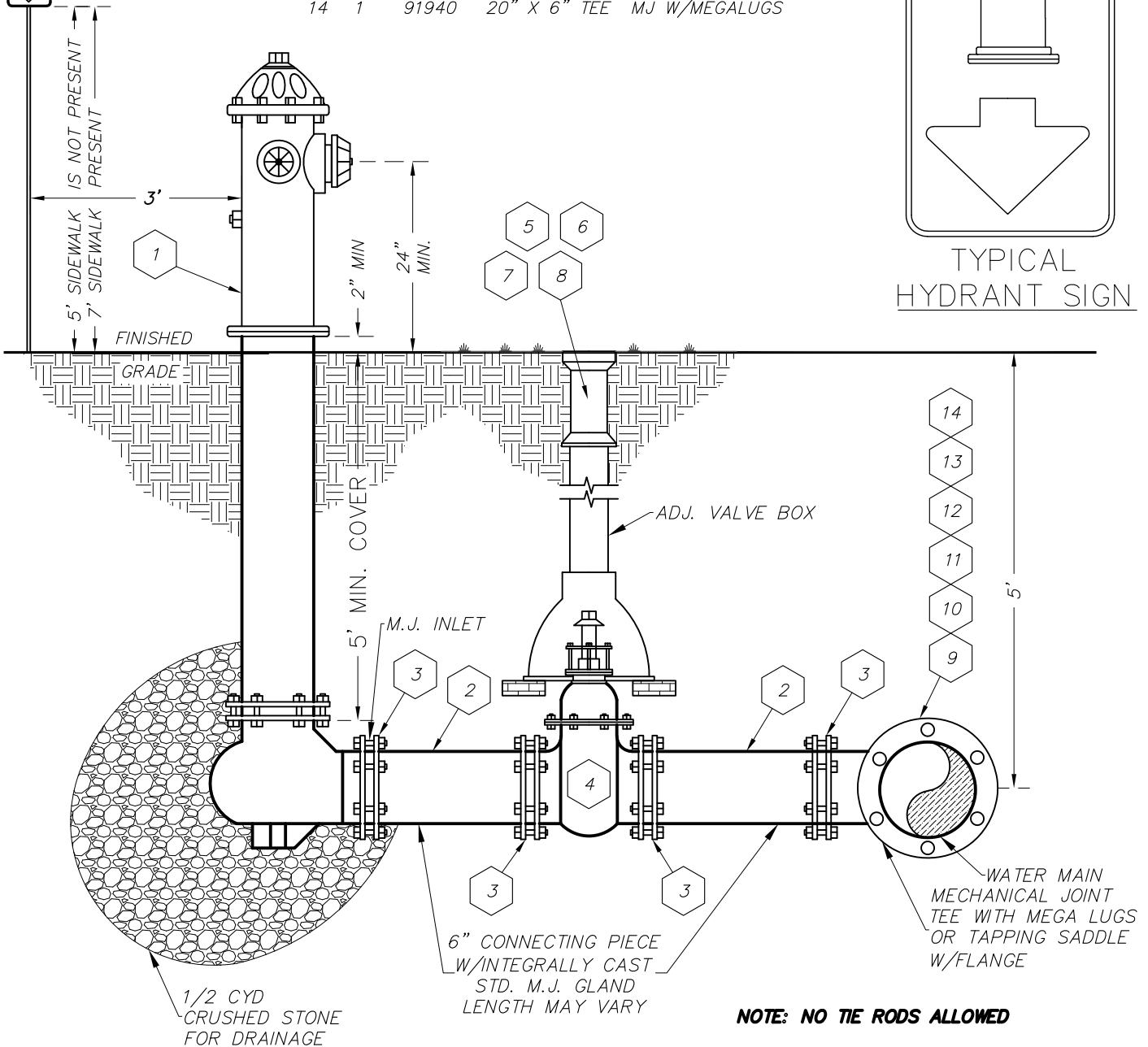

**NOTE: NO TIE RODS ALLOWED**



CITY OF KALAMAZOO  
Department Of Public Services

**TYPICAL FIRE HYDRANT & GATE VALVE DETAIL**

	DATE
RECOMMENDED BY _____	
APPROVED BY _____	
APPROVED BY _____	
ACCEPTED BY _____	

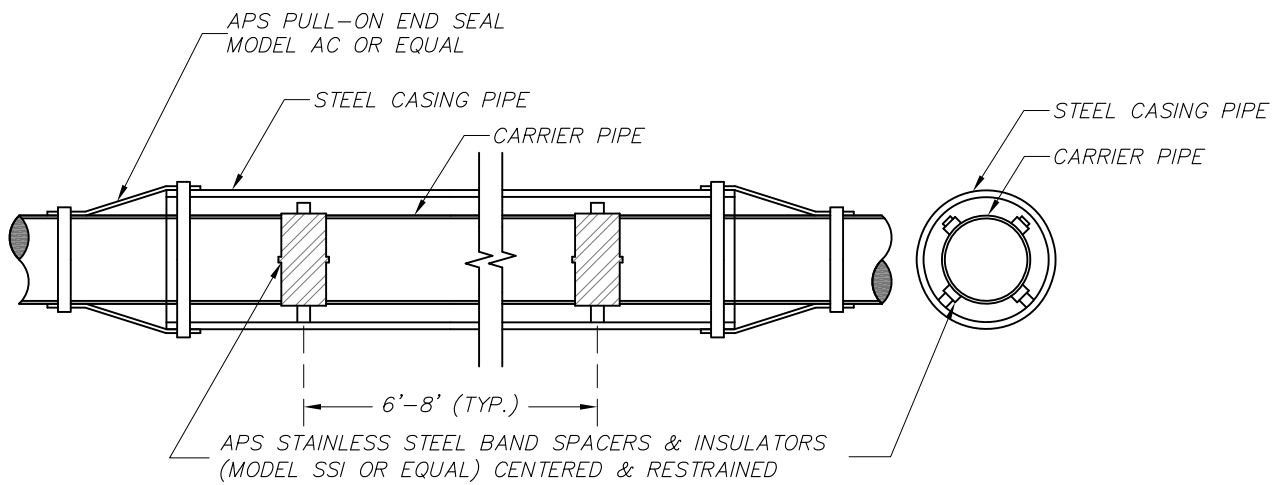

**CASING CARRIER PIPE DETAIL**

SIZE CASING AND CARRIER PIPES PER PLAN AND SPECIFICATIONS

TYPICAL BAND SPACER POSITIONING:  
 ONE PLACED NOT MORE THAN 1 FOOT FROM EACH END OF THE CASING AND  
 PIPE JOINTS WITH SUBSEQUENT SPACERS PLACED EVERY 6-8 FEET THEREAFTER.  
 FOR 18 FOOT PIPE THERE SHALL BE THREE BAND SPACERS.  
 FOR 20 FOOT PIPE THERE SHALL BE FOUR BAND SPACERS.



CITY OF KALAMAZOO  
 Department Of Public Services

**CASING CARRIER PIPE**

RECOMMENDED BY _____	DATE _____
APPROVED BY _____	
APPROVED BY _____	
ACCEPTED BY _____	

WA-3-C

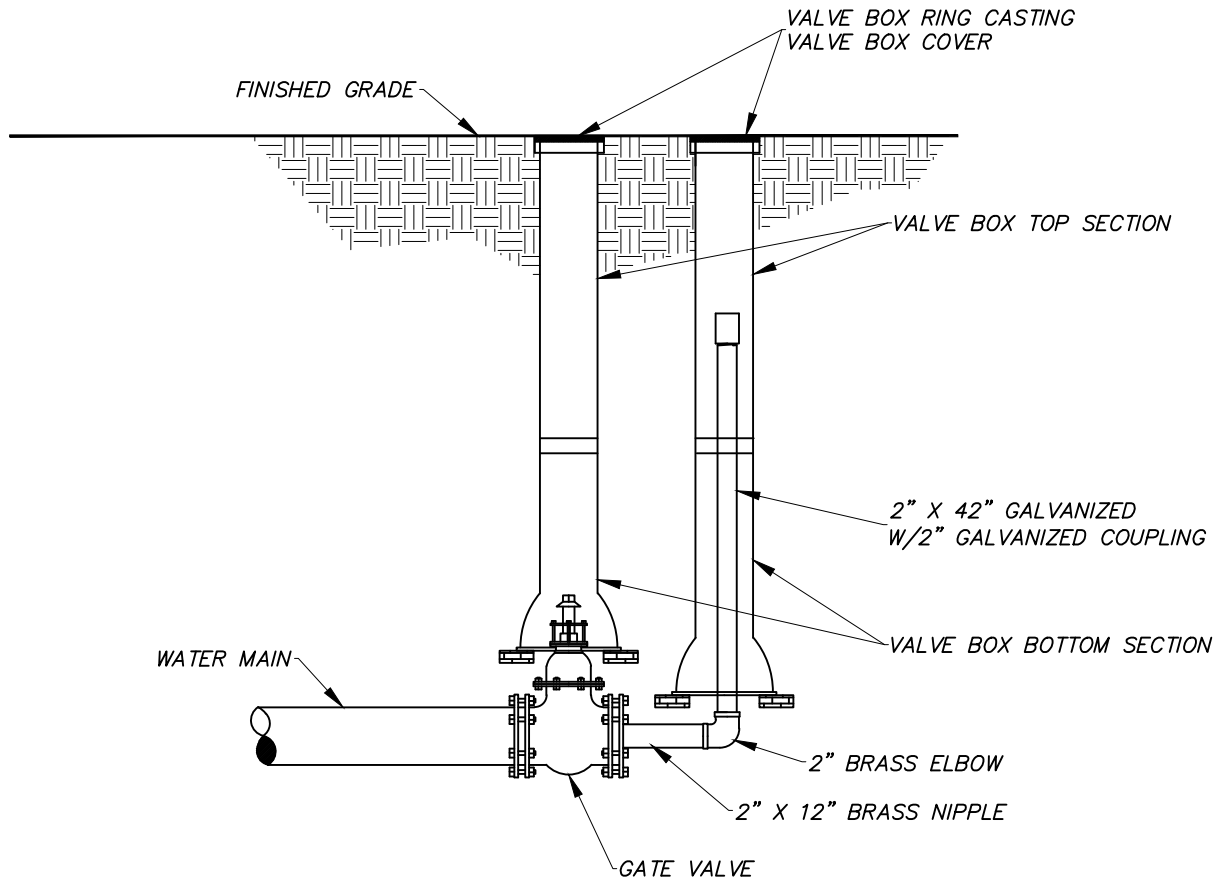

NOT TO SCALE

J:\CAD STANDARDS\STANDARD DETAILS\WATER\UPDATED DRAWINGS\ACAD DRAWINGS\WA-3-B BLOW OFF CONNECTION 2 INCH.dwg, 6/12/2016 12:01:24 PM



CITY OF KALAMAZOO  
Department Of Public Services

### 2" BLOW OFF CONNECTION

	DATE
RECOMMENDED BY _____	
APPROVED BY _____	
APPROVED BY _____	
ACCEPTED BY _____	

**NOTE:**  
LIFT HOLES SHALL BE FILLED  
IN WITH NON-SHRINK MORTAR

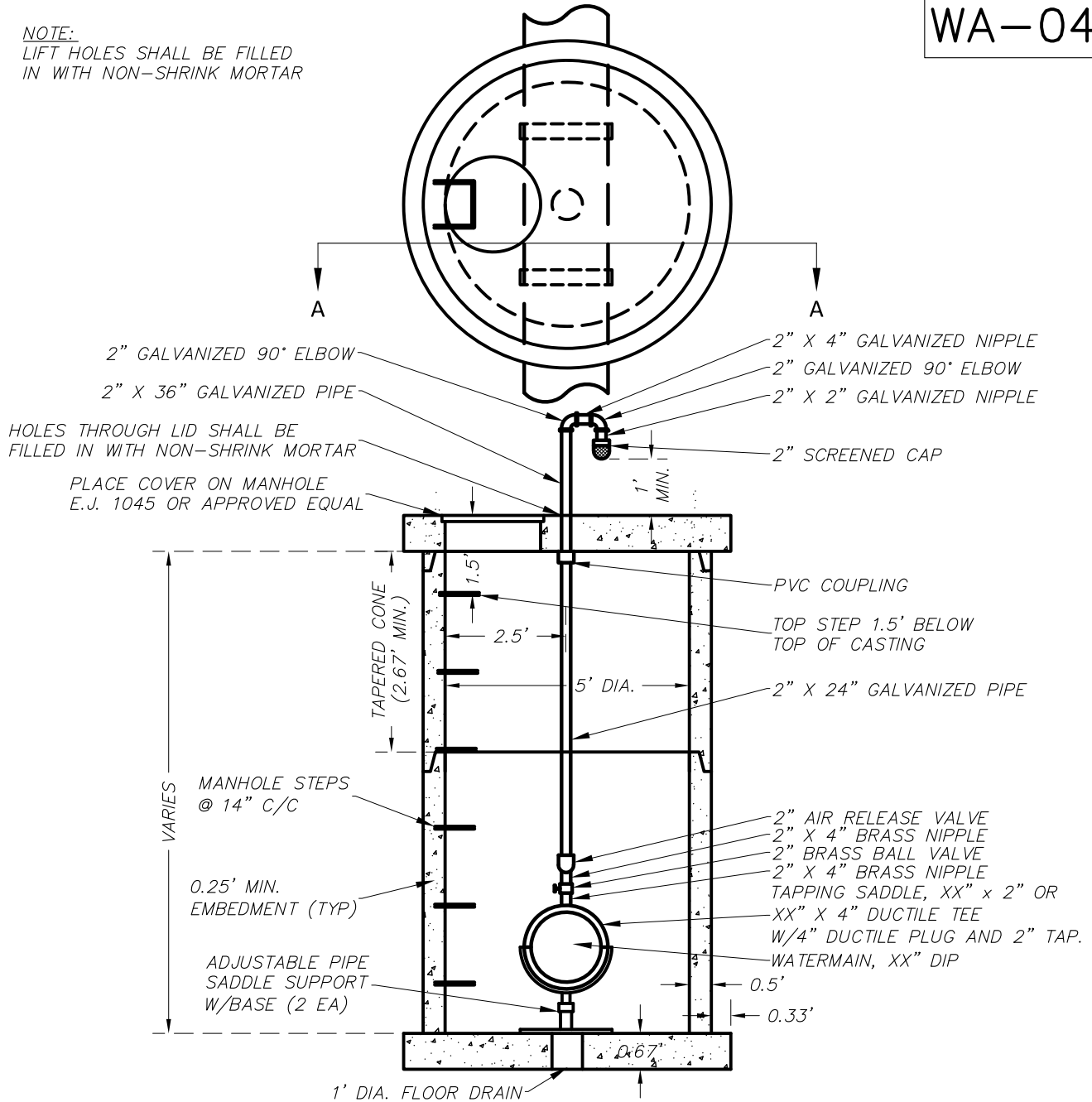

### TYPICAL 2" AIR RELEASE MANHOLE

PRECAST REINFORCED CONCRETE SHOWN (OTHER OPTIONS INCLUDE CONCRETE BLOCK, BRICK OR CAST IN PLACE WALL SECTIONS)

#### SCHEDULE OF FITTINGS

ITEM DESCRIPTION	QUANTITY
AIR RELEASE VALVE, 2"	1
GALVANIZED PIPE, 2" X 60"	1
GALVANIZED NIPPLE, 2" X 4"	1
GALVANIZED NIPPLE, 2" X 2"	1
GALVANIZED 90° ELBOW, 2"	2
PIPE SUPPORT BASE	2

ITEM DESCRIPTION	QUANTITY
TAPPING SADDLE, XX X 2"	1
BRASS BALL VALVE, 2"	1
BRASS NIPPLE, 2" X 4"	2



CITY OF KALAMAZOO  
Department Of Public Services

## AIR RELEASE MANHOLE

RECOMMENDED BY \_\_\_\_\_

APPROVED BY \_\_\_\_\_

APPROVED BY \_\_\_\_\_

ACCEPTED BY \_\_\_\_\_

DATE

WA-05-C

**NOTE:**  
LIFT HOLES SHALL BE FILLED  
IN WITH NON-SHRINK MORTAR

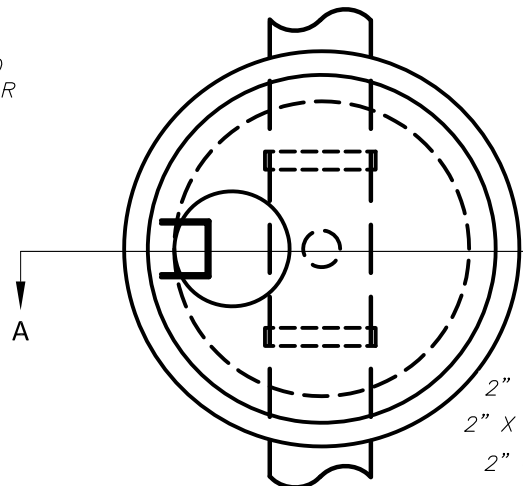

- 2" GALVANIZED 90° ELBOW
- 2" X 4" GALVANIZED NIPPLE
- 2" GALVANIZED 90° ELBOW
- 2" X 2" GALVANIZED NIPPLE
- 2" SCREENED CAP

BOLLARD POSTS  
AS SPECIFIED  
BY ENGINEER

PLACE COVER ON MANHOLE  
E.J. 1045 OR APPROVED EQUAL

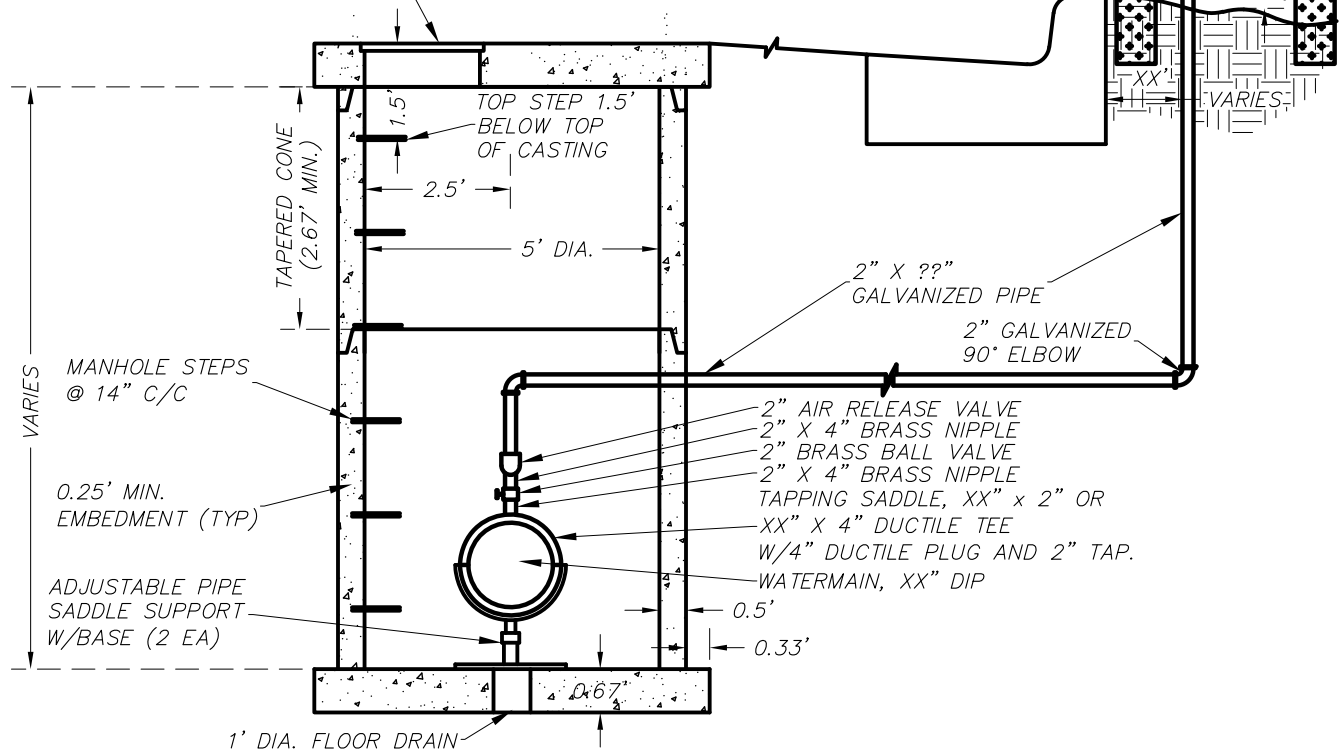

### TYPICAL 2" AIR RELEASE MANHOLE

PRECAST REINFORCED CONCRETE SHOWN (OTHER OPTIONS INCLUDE  
CONCRETE BLOCK, BRICK OR CAST IN PLACE WALL SECTIONS)

#### SCHEDULE OF FITTINGS

ITEM DESCRIPTION	QUANTITY
AIR RELEASE VALVE, 2"	1
GALVANIZED PIPE, 2" X 60"	1
GALVANIZED NIPPLE, 2" X 4"	1
GALVANIZED NIPPLE, 2" X 2"	1
GALVANIZED 90° ELBOW, 2"	2
PIPE SUPPORT BASE	2

ITEM DESCRIPTION	QUANTITY
TAPPING SADDLE, XX X 2"	1
BRASS BALL VALVE, 2"	1
BRASS NIPPLE, 2" X 4"	2

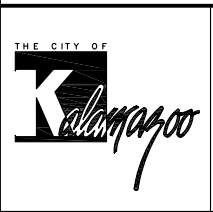

CITY OF KALAMAZOO  
Department Of Public Services

## AIR RELEASE MANHOLE IN ROADWAY

RECOMMENDED BY	DATE
APPROVED BY _____	
APPROVED BY _____	
ACCEPTED BY _____	

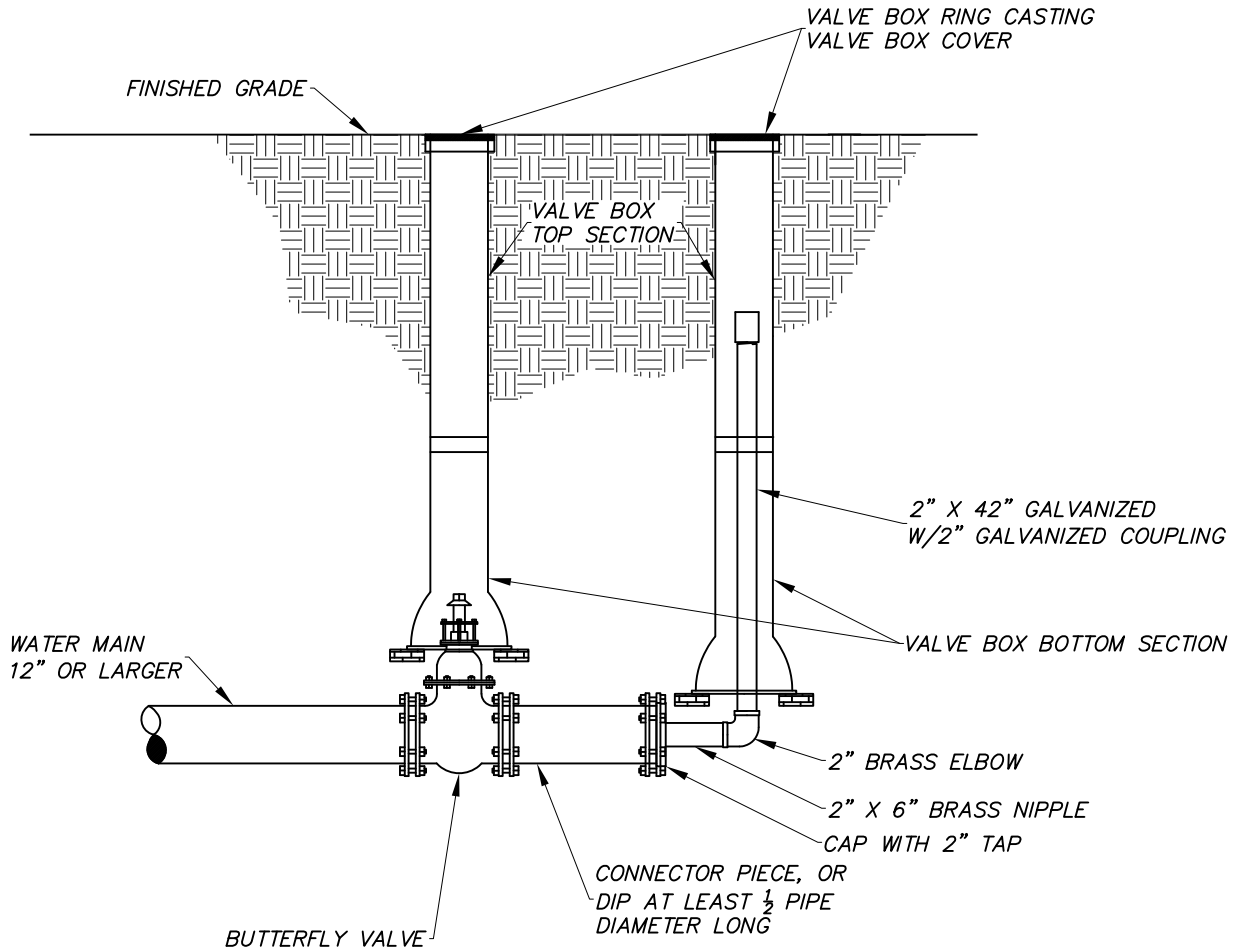

NOT TO SCALE



CITY OF KALAMAZOO  
Department Of Public Services

**2" BLOW OFF  
CONNECTION  
12" OR LARGER MAIN**

RECOMMENDED BY \_\_\_\_\_  
 APPROVED BY \_\_\_\_\_  
 APPROVED BY \_\_\_\_\_  
 ACCEPTED BY \_\_\_\_\_

DATE

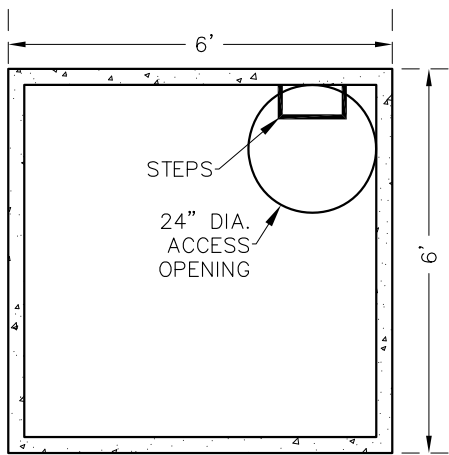

TOP VIEW

- NOTES:
1. METER VAULT DESIGN TO BE SUBMITTED AND APPROVED FOR EACH INDIVIDUAL INSTALLATION. DESIGN SHALL CONFORM TO KALAMAZOO WATER ENGINEERING STANDARDS LATEST REVISION.
  2. THE DISTANCE BETWEEN RUNGS, CLEATS AND STEPS SHALL NOT EXCEED 12 INCHES AND SHALL BE UNIFORM THROUGHOUT THE LENGTH OF THE LADDER.
  3. PLACEMENT OF CURB BOX CAN VARY FROM A MAXIMUM OF 5 FEET OUTSIDE THE PROPERTY LINE TO A MAXIMUM OF 5 FEET INSIDE THE PROPERTY LINE. PLACEMENT OF THE CURB BOX OUTSIDE THE PROPERTY LINE IS PREFERRED.
  4. ACCESS COVER - FORD MC-24-MB-T WITH AN INNER LID, VESTAL 32-055, 32-104, AND 32-046 OR APPROVED EQUAL.

TOP OF PIT TO FINAL GRADE SHALL NOT EXCEED 8"

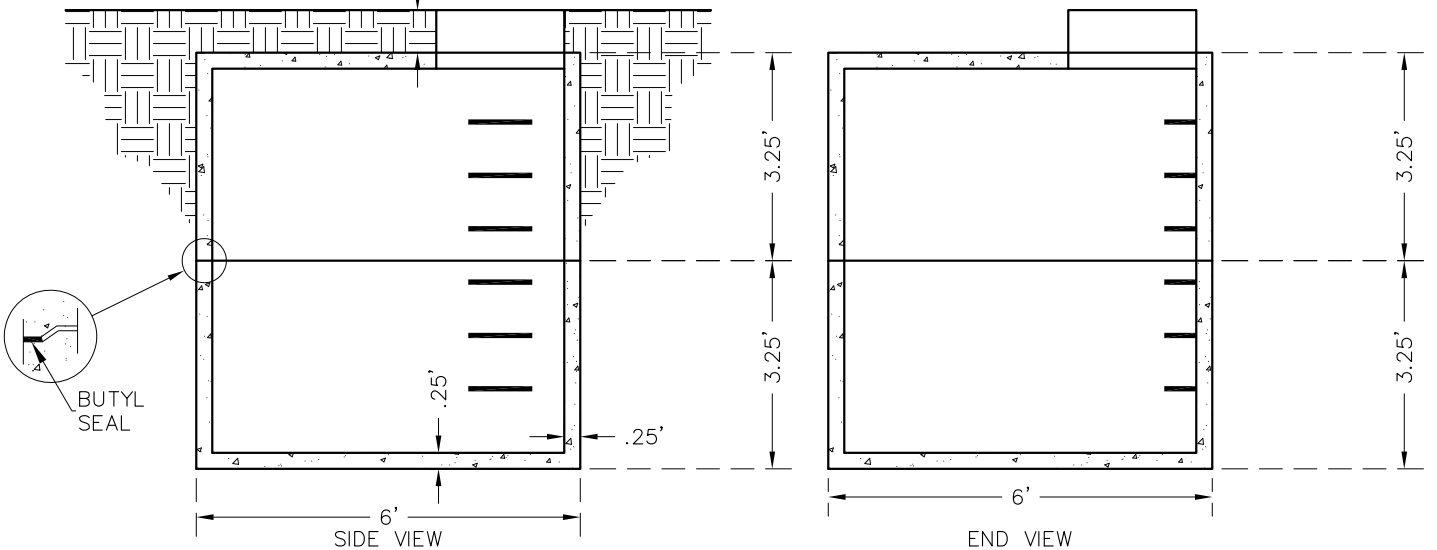

SIDE VIEW

END VIEW



CITY OF KALAMAZOO  
Department Of Public Services

**STANDARD METER PIT**

RECOMMENDED BY _____	DATE
APPROVED BY _____	
APPROVED BY _____	
ACCEPTED BY _____	



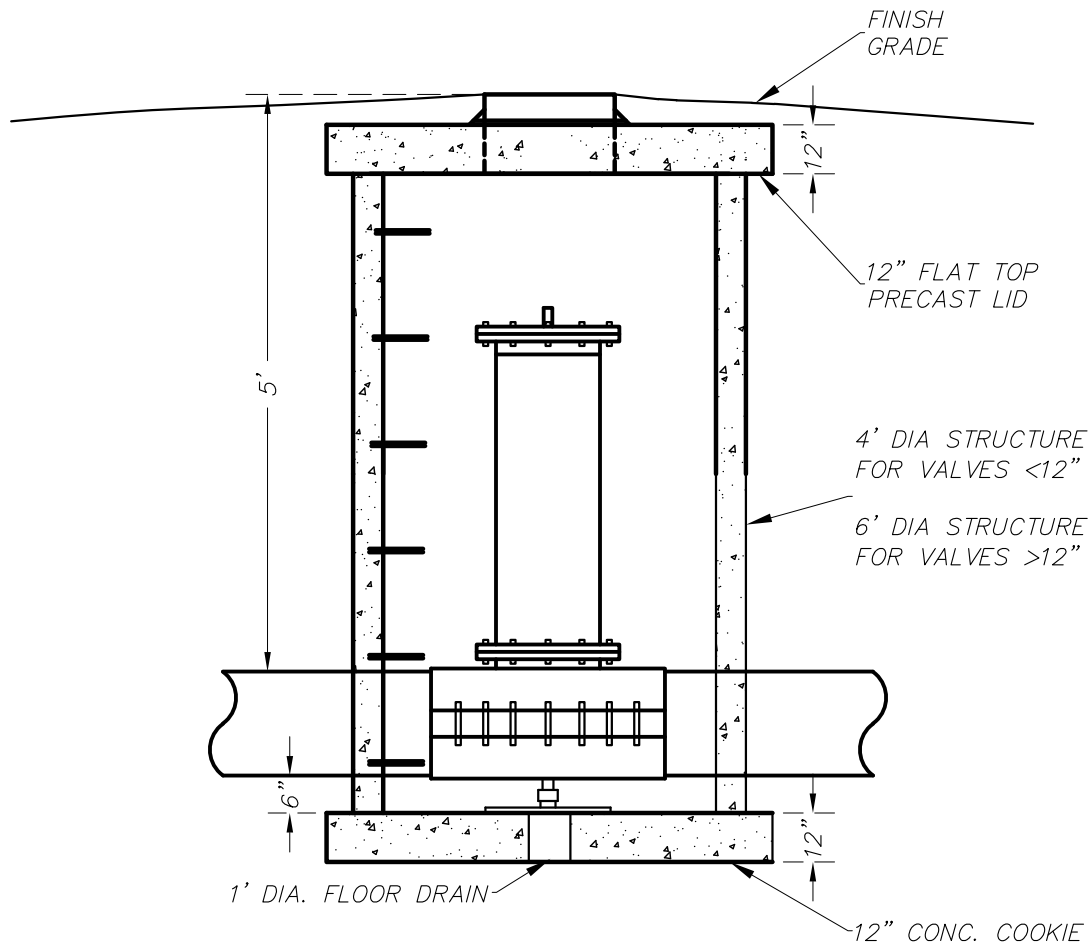
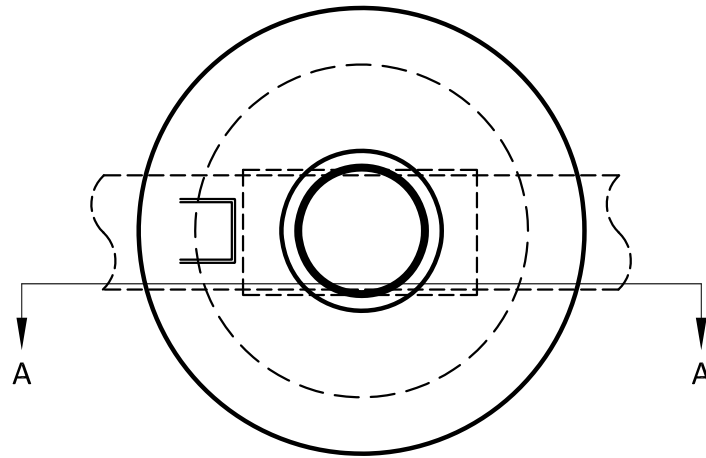

**TYPICAL INSERTA – VALVE**  
*PRECAST REINFORCED CONCRETE SHOWN*



CITY OF KALAMAZOO  
 Department Of Public Services

**INSERTA-VALVE  
 STRUCTURE**

RECOMMENDED BY \_\_\_\_\_

APPROVED BY \_\_\_\_\_

APPROVED BY \_\_\_\_\_

ACCEPTED BY \_\_\_\_\_

DATE

NOTES:

1. METER VAULT (PIT) DESIGN MUST BE SUBMITTED AND APPROVED FOR EACH INDIVIDUAL INSTALLATION. DESIGN SHALL CONFORM TO THE CITY OF KALAMAZOO STANDARD SPECIFICATIONS FOR WATER MAIN AND SERVICE INSTALLATION LATEST REVISION.
2. THE DISTANCE BETWEEN RUNGS, CLEATS & STEPS SHALL NOT EXCEED 12 INCHES AND SHALL BE UNIFORM THROUGHOUT THE LENGTH OF THE LADDER.
3. CURB BOX WILL BE INSTALLED AT THE WATER MAIN.
4. COVER FOR METER PIT & CURB BOX SHALL BE INSTALLED & MAINTAINED LEVEL WITH THE ADJACENT GROUND.

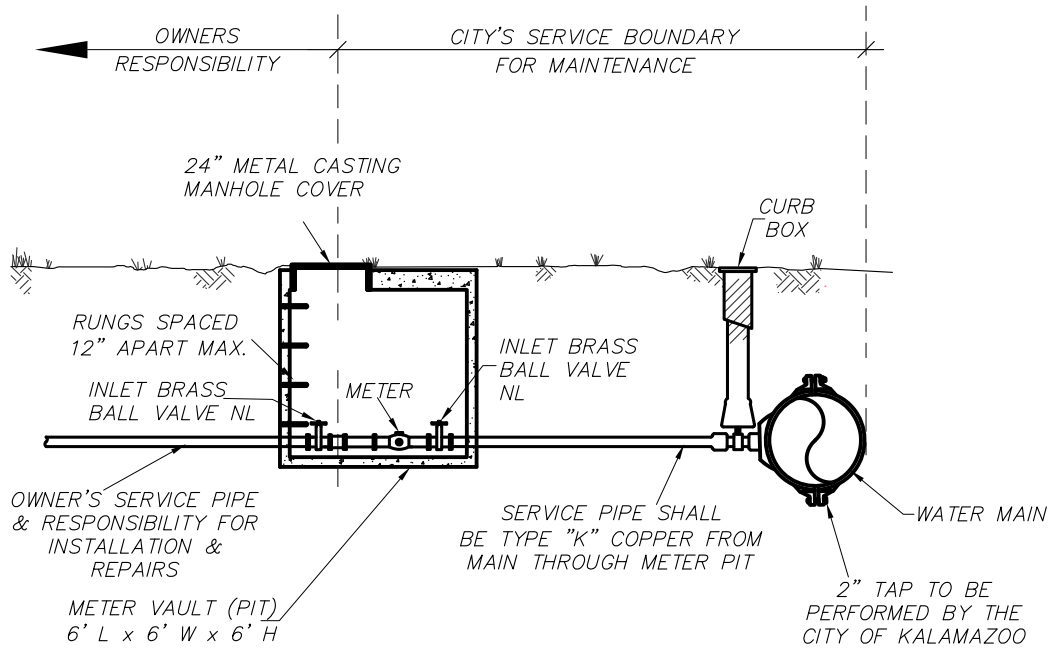

CITY OF KALAMAZOO  
Department Of Public Services

**2" SERVICE LINE  
METER VAULT**

RECOMMENDED BY \_\_\_\_\_

APPROVED BY \_\_\_\_\_

APPROVED BY \_\_\_\_\_

ACCEPTED BY \_\_\_\_\_

DATE

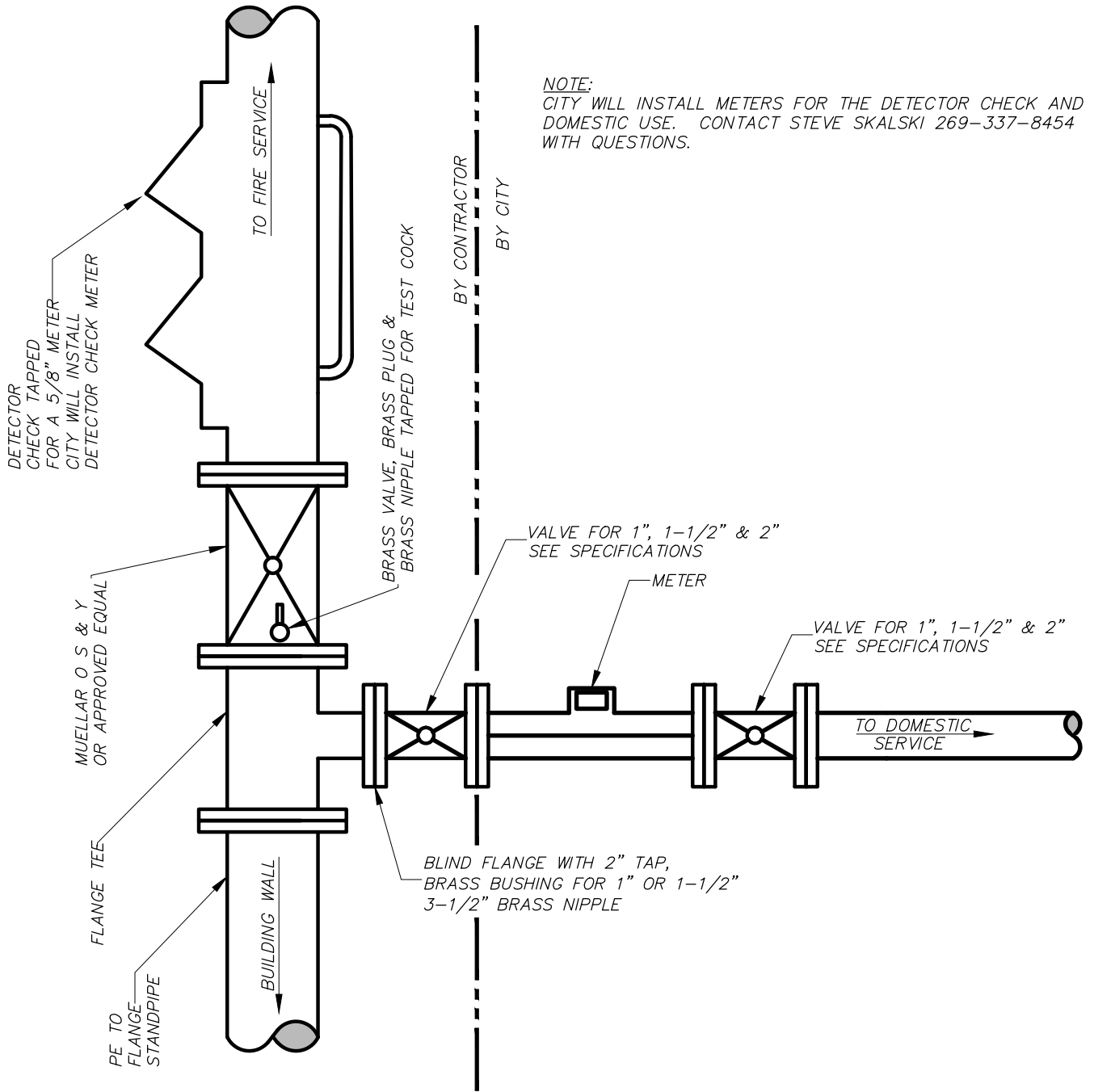

CITY OF KALAMAZOO  
Department Of Public Services  
**TYPICAL FIRE SERVICE**  
**DETAIL**  
1" 1-1/2" 2"

RECOMMENDED BY _____	DATE
APPROVED BY _____	
APPROVED BY _____	
ACCEPTED BY _____	

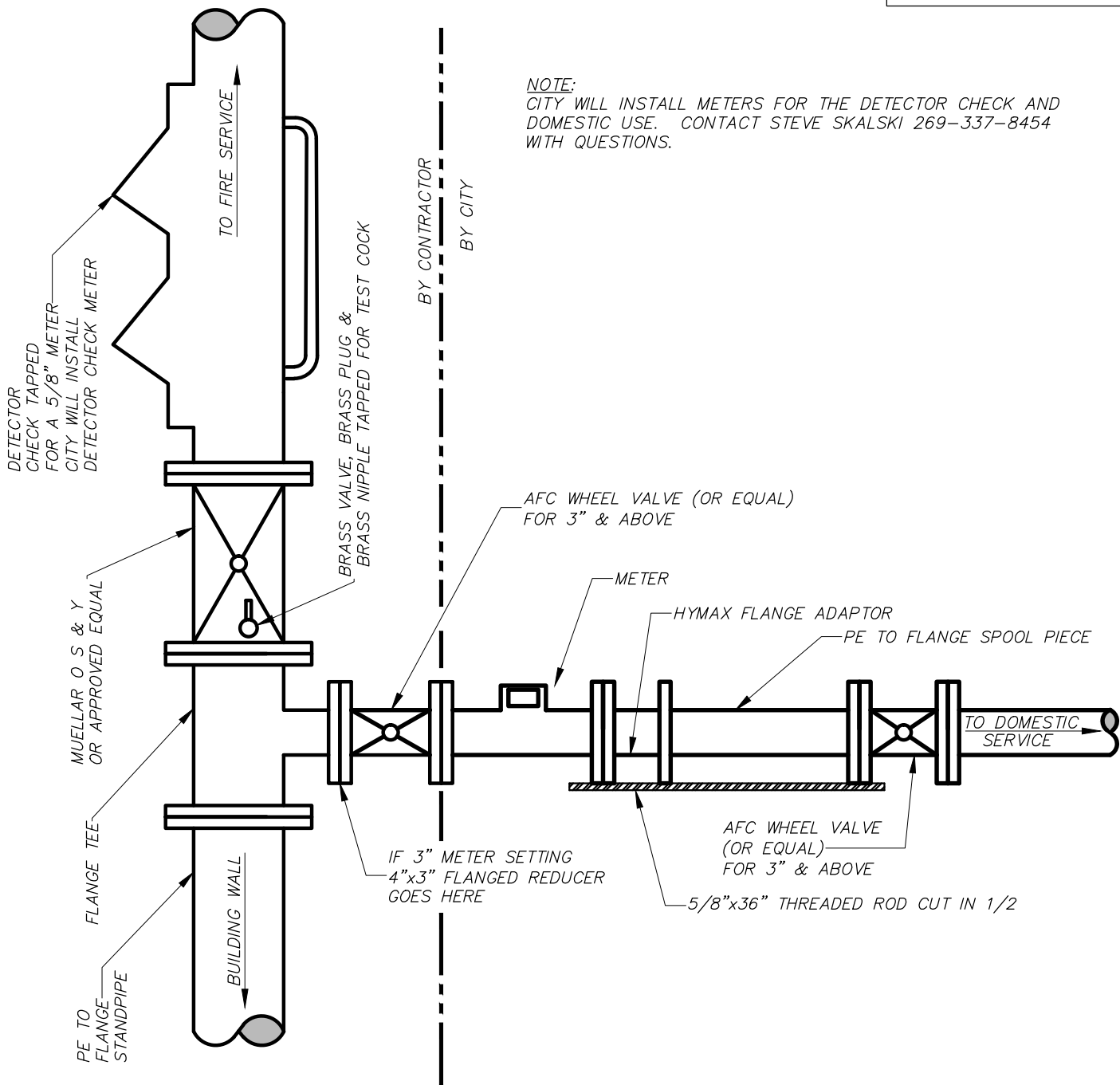

CITY OF KALAMAZOO  
Department Of Public Services  
**TYPICAL FIRE SERVICE  
DETAIL**  
3" 4" 6"

RECOMMENDED BY _____	DATE _____
APPROVED BY _____	
APPROVED BY _____	
ACCEPTED BY _____	

NOTES:

1. PLACEMENT OF STOP BOX CAN VARY FROM A MAXIMUM OF 5 FEET OUTSIDE THE PROPERTY LINE TO A MAXIMUM OF 5 FEET INSIDE THE PROPERTY LINE. PLACEMENT OF THE STOP BOX OUTSIDE THE PROPERTY LINE IS PREFERRED.

2. CITY WATER WILL REPAIR LEAKS ON SERVICE LINES WHEN NOTIFIED, FROM THE CORPORATION STOP TO METER.

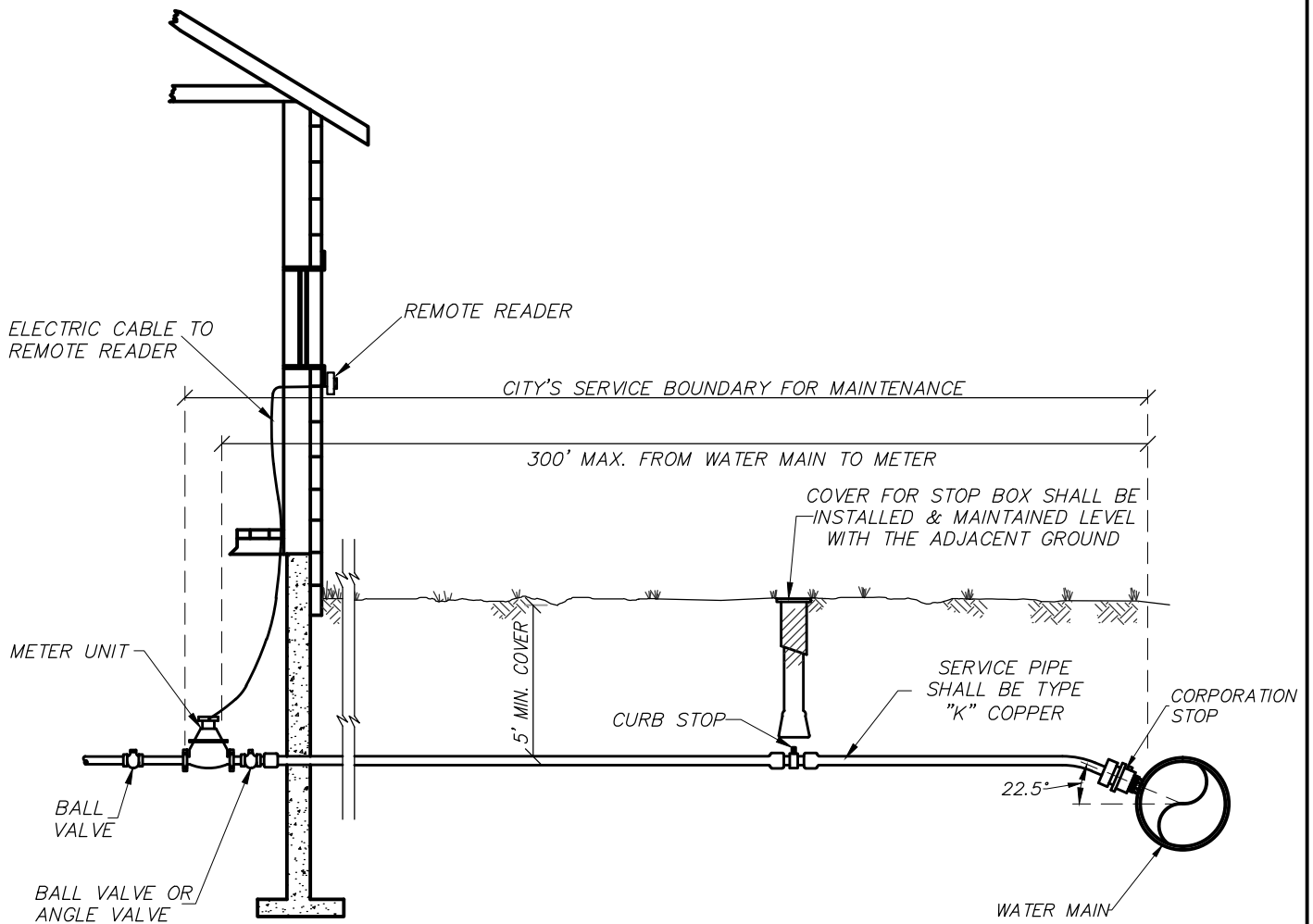

9/15/2015 1:27:03 PM



CITY OF KALAMAZOO  
Department Of Public Services

**SERVICE LINE, STOP BOX AND  
INSIDE METER INSTALLATION  
1-1/4" SERVICE & 1" METER**

	DATE
RECOMMENDED BY _____	
APPROVED BY _____	
APPROVED BY _____	
ACCEPTED BY _____	

WS-7-A

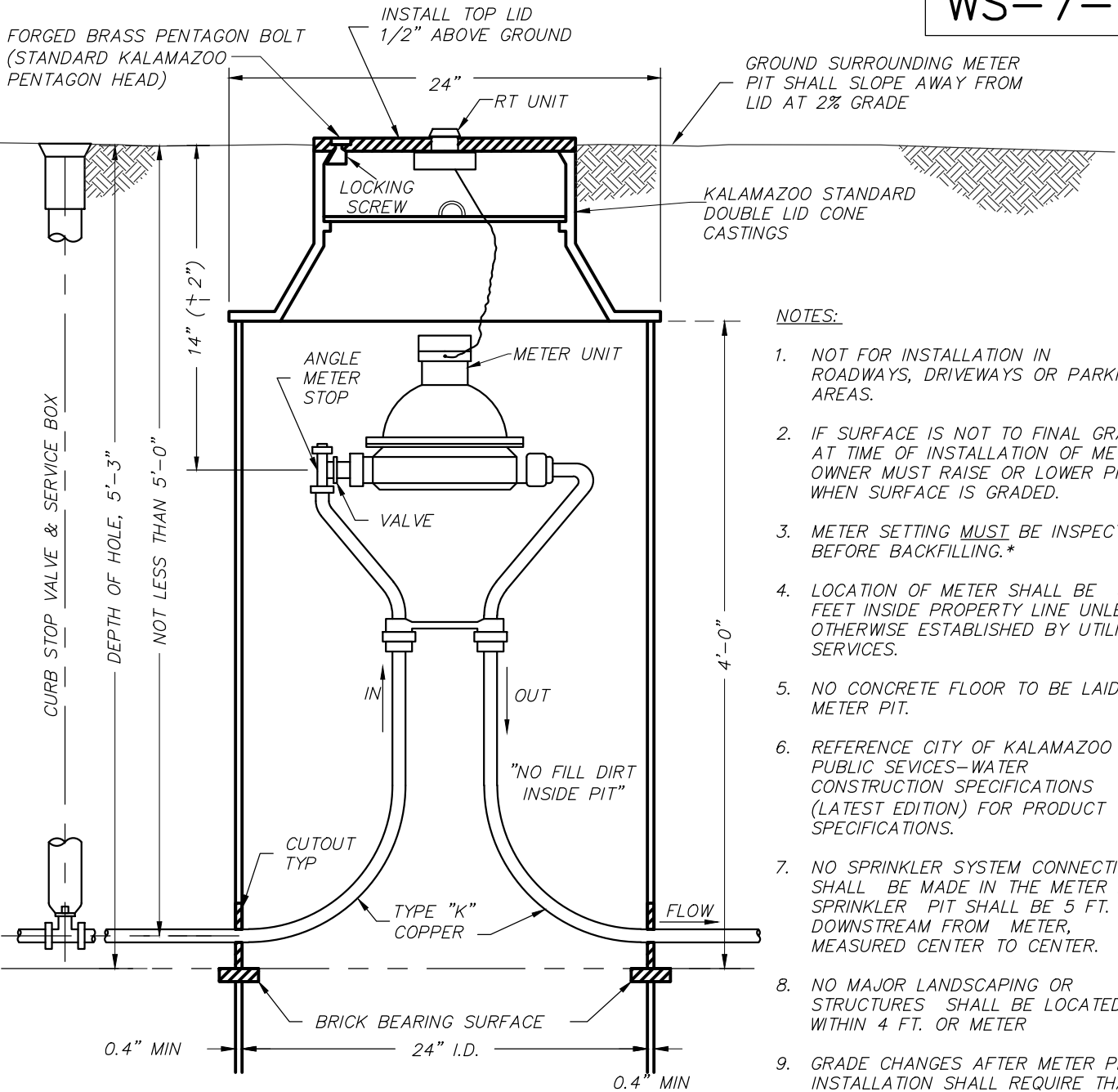

**NOTES:**

1. NOT FOR INSTALLATION IN ROADWAYS, DRIVEWAYS OR PARKING AREAS.
2. IF SURFACE IS NOT TO FINAL GRADE AT TIME OF INSTALLATION OF METER, OWNER MUST RAISE OR LOWER PIT WHEN SURFACE IS GRADED.
3. METER SETTING MUST BE INSPECTED BEFORE BACKFILLING.\*
4. LOCATION OF METER SHALL BE 5 FEET INSIDE PROPERTY LINE UNLESS OTHERWISE ESTABLISHED BY UTILITY SERVICES.
5. NO CONCRETE FLOOR TO BE LAID IN METER PIT.
6. REFERENCE CITY OF KALAMAZOO PUBLIC SERVICES-WATER CONSTRUCTION SPECIFICATIONS (LATEST EDITION) FOR PRODUCT SPECIFICATIONS.
7. NO SPRINKLER SYSTEM CONNECTIONS SHALL BE MADE IN THE METER PIT. SPRINKLER PIT SHALL BE 5 FT. DOWNSTREAM FROM METER, MEASURED CENTER TO CENTER.
8. NO MAJOR LANDSCAPING OR STRUCTURES SHALL BE LOCATED WITHIN 4 FT. OF METER
9. GRADE CHANGES AFTER METER PIT INSTALLATION SHALL REQUIRE THAT THE OWNER ADJUST METER PIT COVER TO 1/2" ABOVE FINAL GRADE.
10. IF PRESSURE REDUCING VALVE IS REQUIRED BY PLUMBING CODE, IT SHALL BE INSTALLED INSIDE THE BUILDING, IMMEDIATELY FOLLOWING THE MAIN SHUT OFF VALVE.
11. COPPER PIPE SHALL SHOW NO VISIBLE CRIMPING.

\* FOR INSPECTION CALL (269) 998-6433 INSPECTOR  
 \* FOR INSPECTION CALL (269) 337-8769 ENGINEER

J:\COK CAD STANDARDS\STANDARD DETAILS\WATER\UPDATED DRAWINGS\WS-7-A OUTSIDE METER 1 INCH.dwg, 4/1/2014 8:18:07 AM



CITY OF KALAMAZOO  
 Department Of Public Services

**OUTSIDE SETTING FOR  
 1" METER**

RECOMMENDED BY _____	DATE _____
APPROVED BY _____	
APPROVED BY _____	
ACCEPTED BY _____	

NOTES:

PLACEMENT OF STOP BOX CAN VARY FROM A MAXIMUM OF 5 FOOT OUTSIDE THE PROPERTY LINE TO A MAXIMUM OF 5 FOOT INSIDE THE PROPERTY LINE TO AVOID SIDEWALK. PLACEMENT OF STOP BOX OUTSIDE THE PROPERTY LINE IS PREFERRED.

OWNER'S RESPONSIBILITY SHALL BE UP TO 5 FEET FROM THE METER PIT CUSTOMER SIDE.

WATER DEPARTMENT'S RESPONSIBILITY SHALL BE THE WATER MAIN, THE CORPORATION STOP AND SERVICE PIPING UP TO 5 FEET FROM THE METER

METER PIT AND COVER SHALL BE THE RESPONSIBILITY OF THE OWNER.

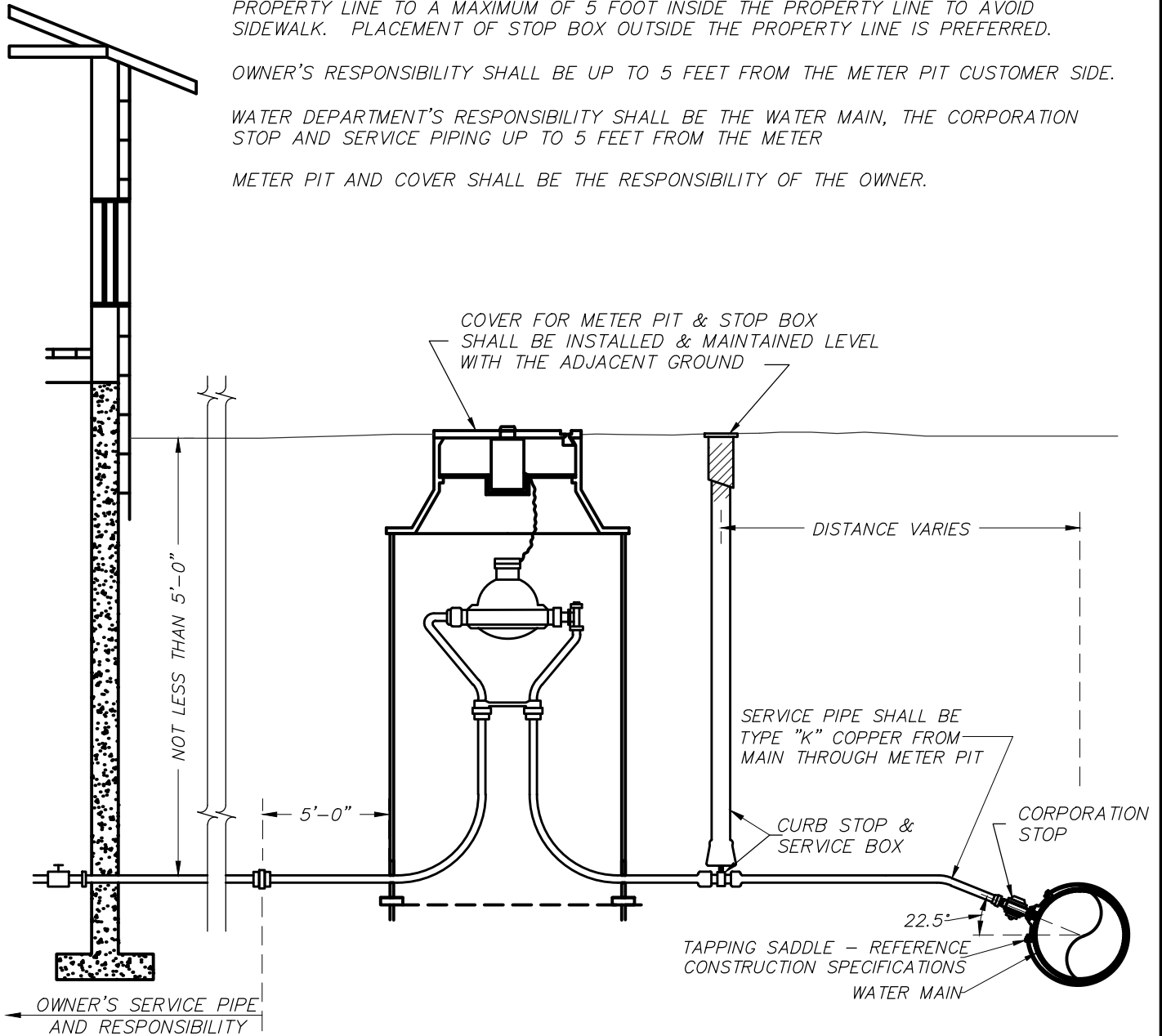

9/15/2015 12:06:36 PM



CITY OF KALAMAZOO  
Department Of Public Services

**1-1/4" SERVICE LINE,  
STOP BOX AND OUTSIDE  
METER INSTALLATION**

RECOMMENDED BY _____	DATE
APPROVED BY _____	
APPROVED BY _____	
ACCEPTED BY _____	

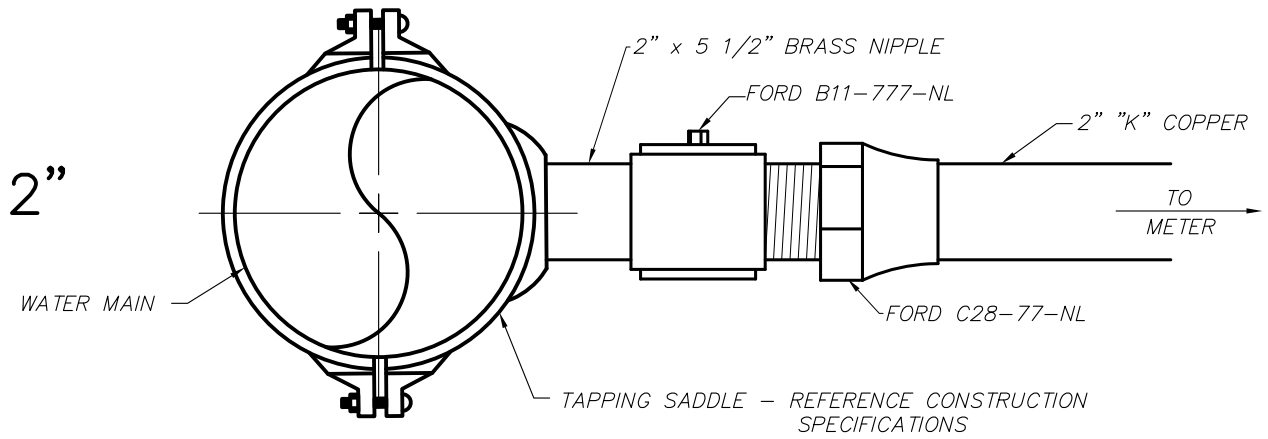
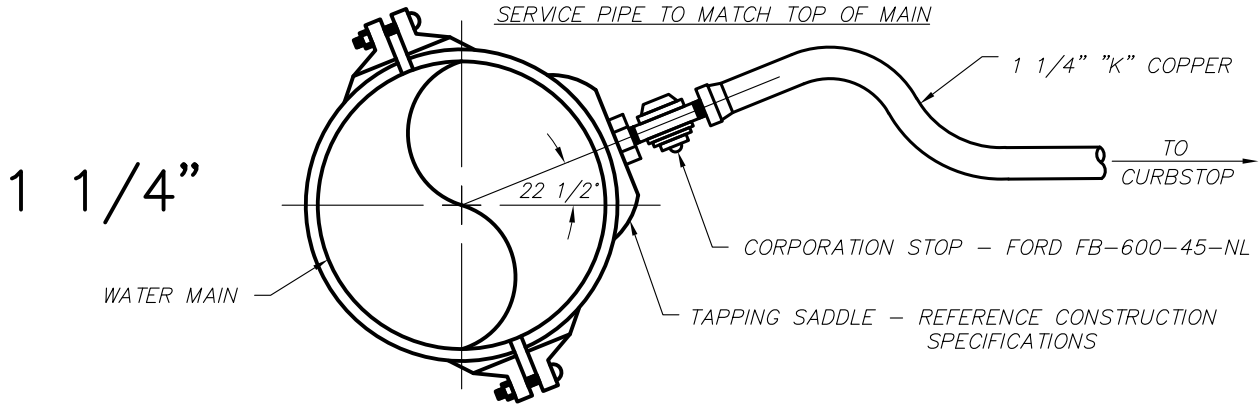

CITY OF KALAMAZOO  
Department Of Public Services

**WATER SERVICE  
TAPPING SLEEVE**

RECOMMENDED BY \_\_\_\_\_

APPROVED BY \_\_\_\_\_

APPROVED BY \_\_\_\_\_

ACCEPTED BY \_\_\_\_\_

DATE



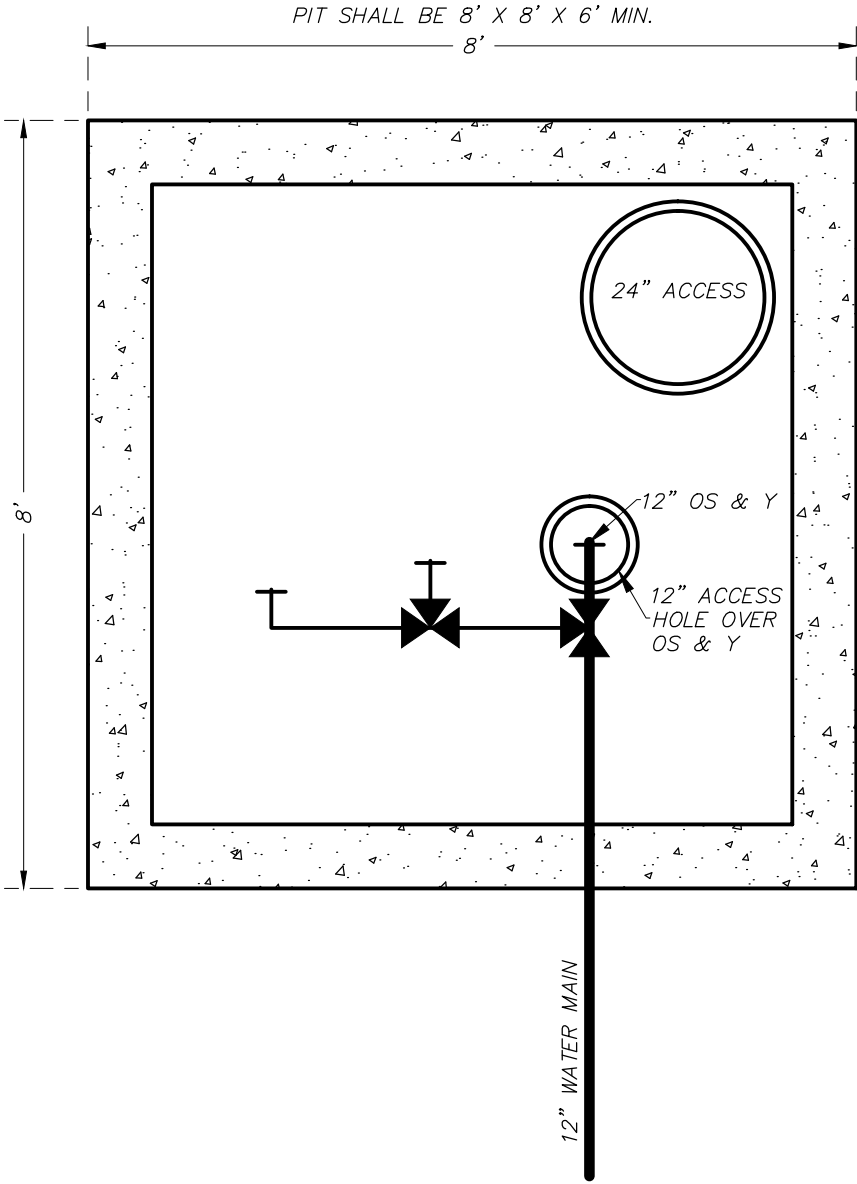

CITY OF KALAMAZOO  
Department Of Public Services

### 12 INCH METER PIT

	DATE
RECOMMENDED BY _____	
APPROVED BY _____	
APPROVED BY _____	
ACCEPTED BY _____	

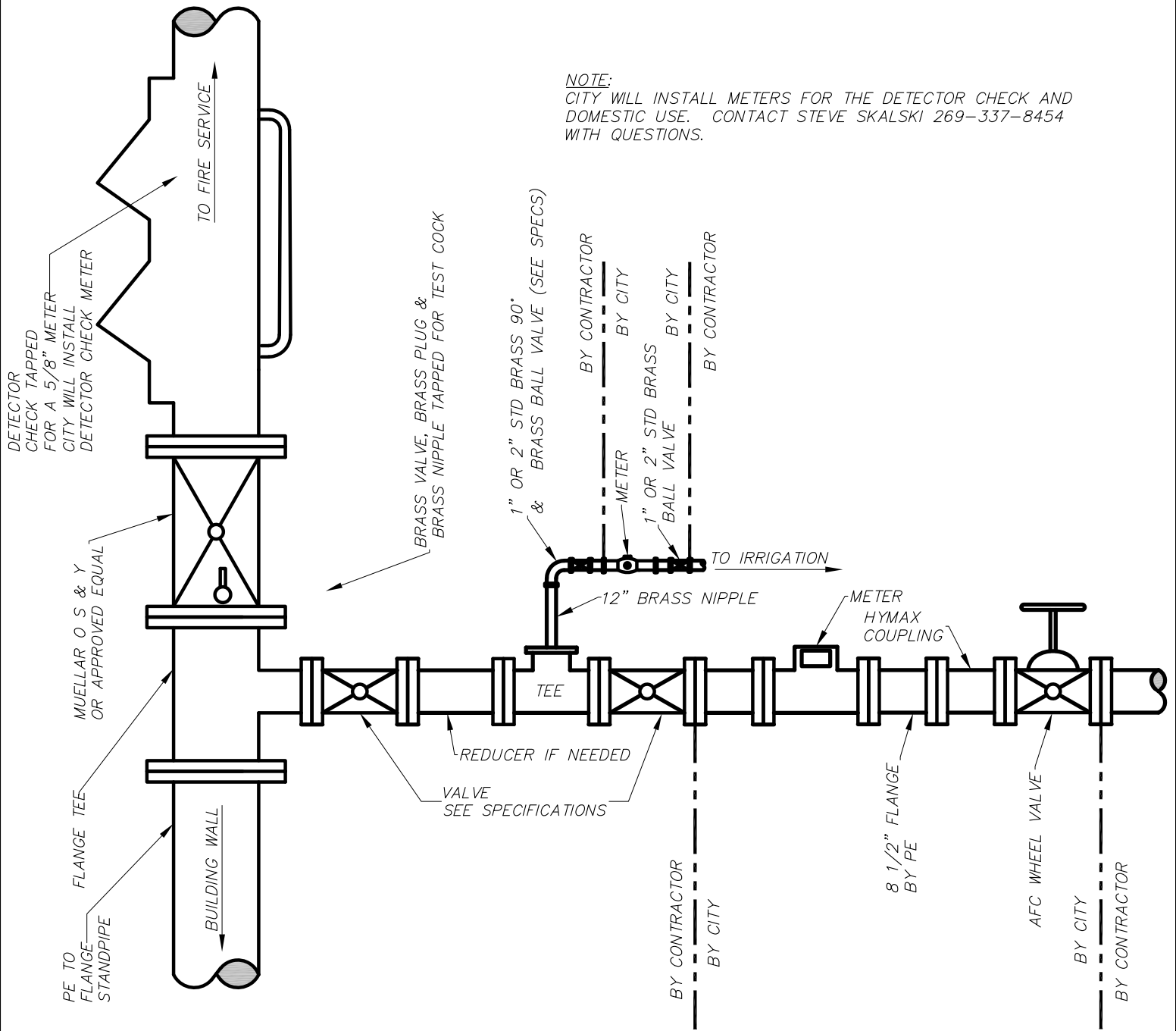

**TYPICAL FIRE SERVICE  
DETAIL, DOMESTIC 3", 4",  
& 6" & IRRIGATION 1" OR  
2" VERTICAL SETTING**

RECOMMENDED BY \_\_\_\_\_

APPROVED BY \_\_\_\_\_

APPROVED BY \_\_\_\_\_

ACCEPTED BY \_\_\_\_\_

DATE

**NOTE:**  
 CITY WILL INSTALL METERS FOR THE DETECTOR CHECK AND  
 DOMESTIC USE. CONTACT STEVE SKALSKI 269-337-8454  
 WITH QUESTIONS.

1" OR 2" STD. 90°  
 W/1" OR 2" BRASS BALL VALVE  
 OR FORD ANGLE VALVE  
 (FV13-777W-NL) 2"  
 (KV13-444W-NL) 1"

1" OR 2" X 12" BRASS NIPPLE

VALVE  
 SEE SPECIFICATIONS

REDUCER  
 (IF NEEDED)

TEE

TEE

PE TO  
 FLANGE  
 STANDPIPE

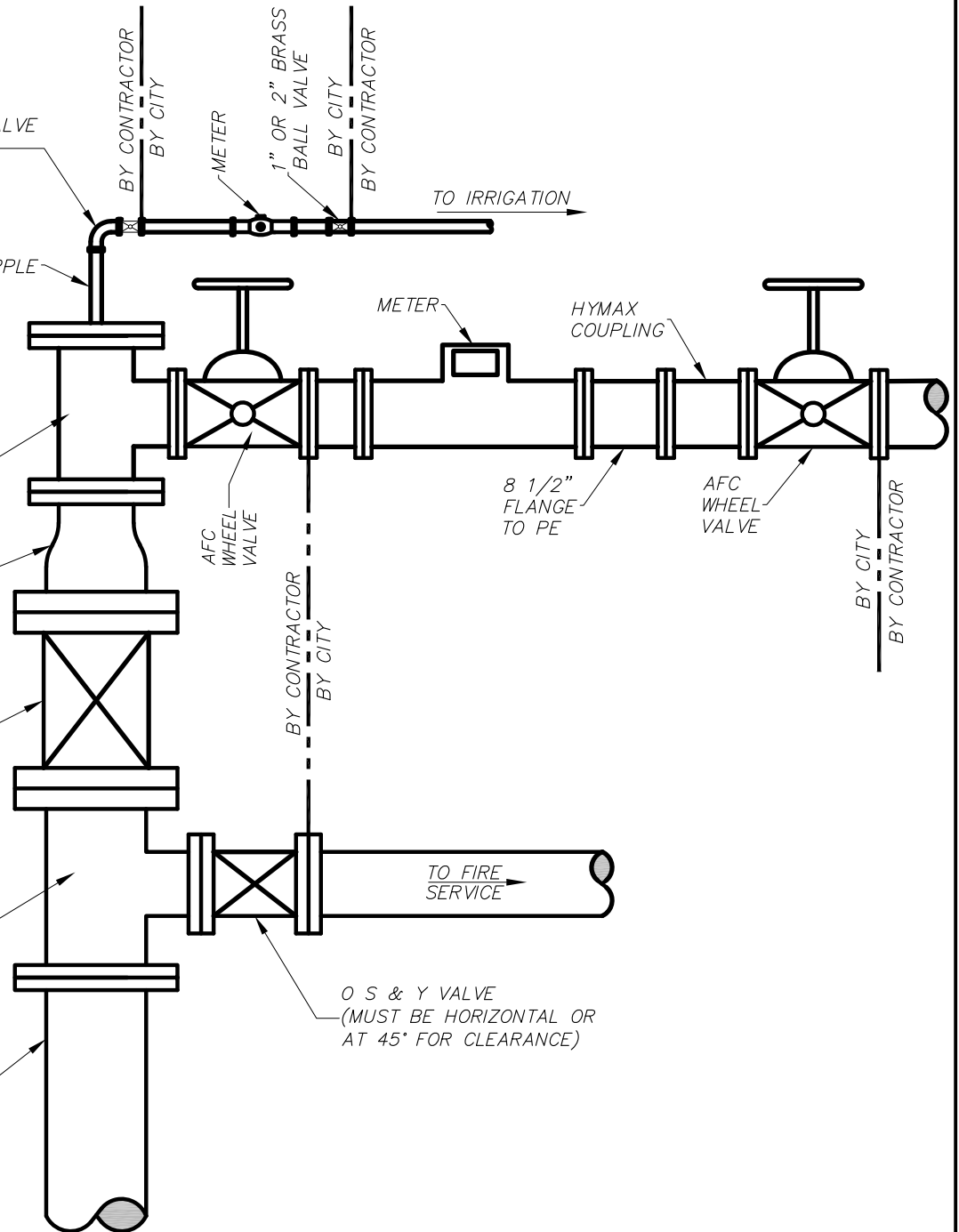

TO IRRIGATION

TO FIRE  
 SERVICE

O S & Y VALVE  
 (MUST BE HORIZONTAL OR  
 AT 45° FOR CLEARANCE)



CITY OF KALAMAZOO  
 Department Of Public Services  
**TYPICAL FIRE SERVICE DETAIL**  
**HORIZONTAL SETTING**  
**W/3", 4", OR 6" DOMESTIC**  
**& 1" OR 2" IRRIGATION**

RECOMMENDED BY _____	DATE _____
APPROVED BY _____	
APPROVED BY _____	
ACCEPTED BY _____	

NOTE:  
 CITY WILL INSTALL METERS FOR THE DETECTOR CHECK AND  
 DOMESTIC USE. CONTACT STEVE SKALSKI 269-337-8454  
 WITH QUESTIONS.

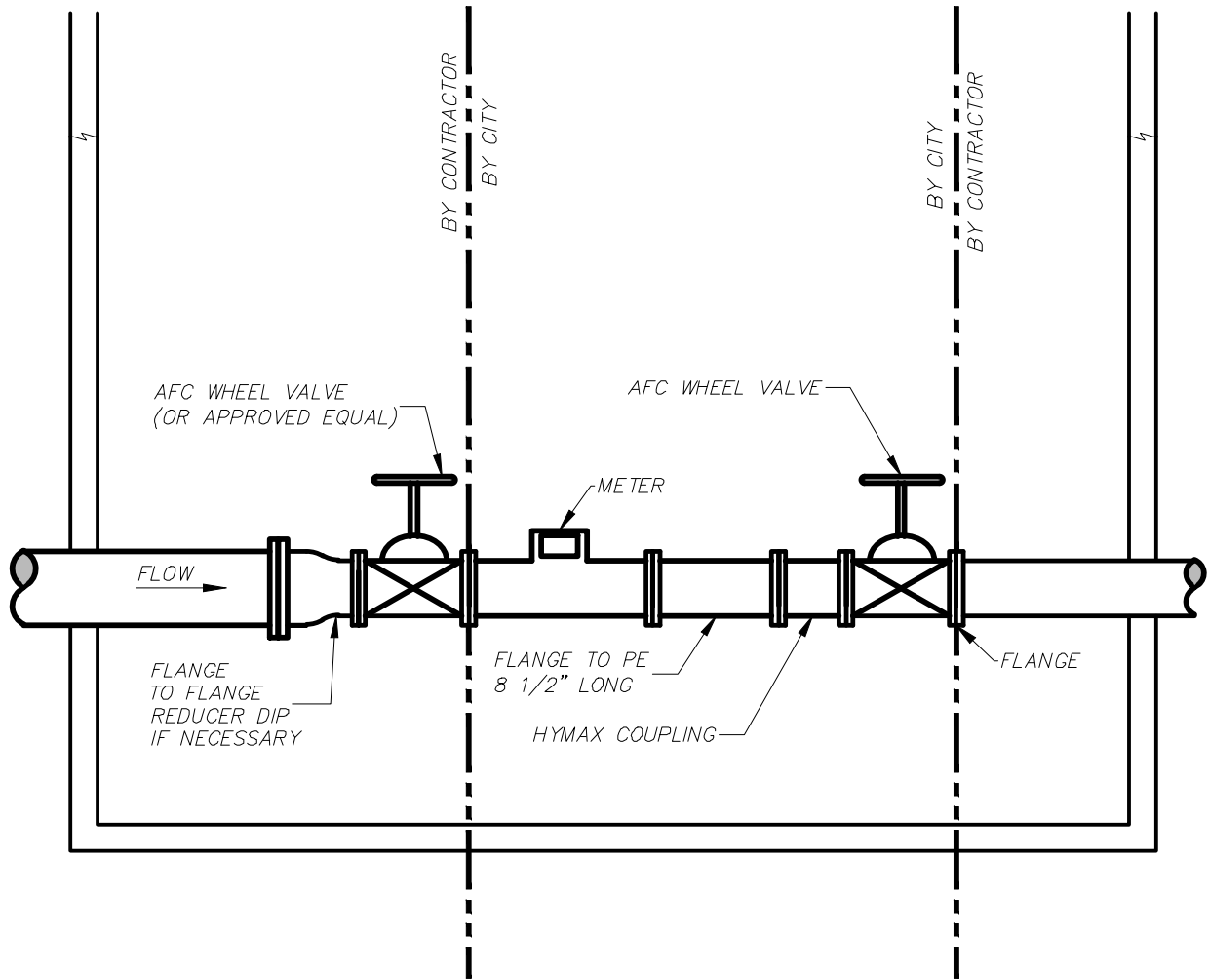

CITY OF KALAMAZOO  
 Department Of Public Services  
**PIT METER SETTING  
 DETAIL FOR  
 3", 4", 6" & 8"**

RECOMMENDED BY _____	DATE _____
APPROVED BY _____	
APPROVED BY _____	
ACCEPTED BY _____	

**NOTE:**  
CITY WILL INSTALL METERS FOR THE DETECTOR CHECK AND DOMESTIC USE. CONTACT STEVE SKALSKI 269-337-8454 WITH QUESTIONS.

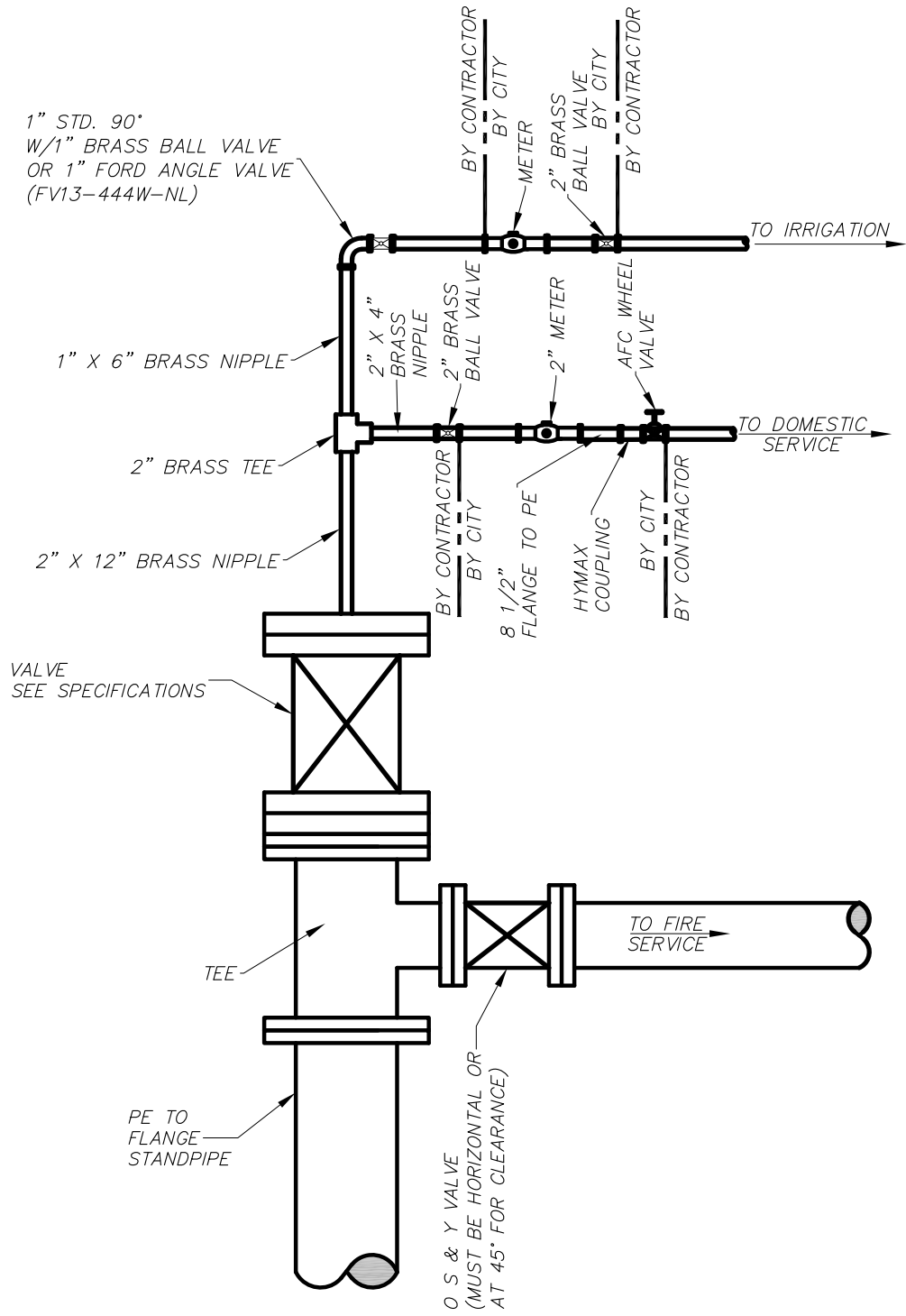

	CITY OF KALAMAZOO Department Of Public Services	RECOMMENDED BY _____	DATE
	<b>TYPICAL FIRE SERVICE DETAIL</b> <b>HORIZONTAL SETTING</b> <b>2" DOMESTIC</b> <b>1" IRRIGATION</b>	APPROVED BY _____	
		APPROVED BY _____	
		ACCEPTED BY _____	

NOTE:  
 CITY WILL INSTALL METERS FOR THE DETECTOR CHECK AND  
 DOMESTIC USE. CONTACT STEVE SKALSKI 269-337-8454  
 WITH QUESTIONS.

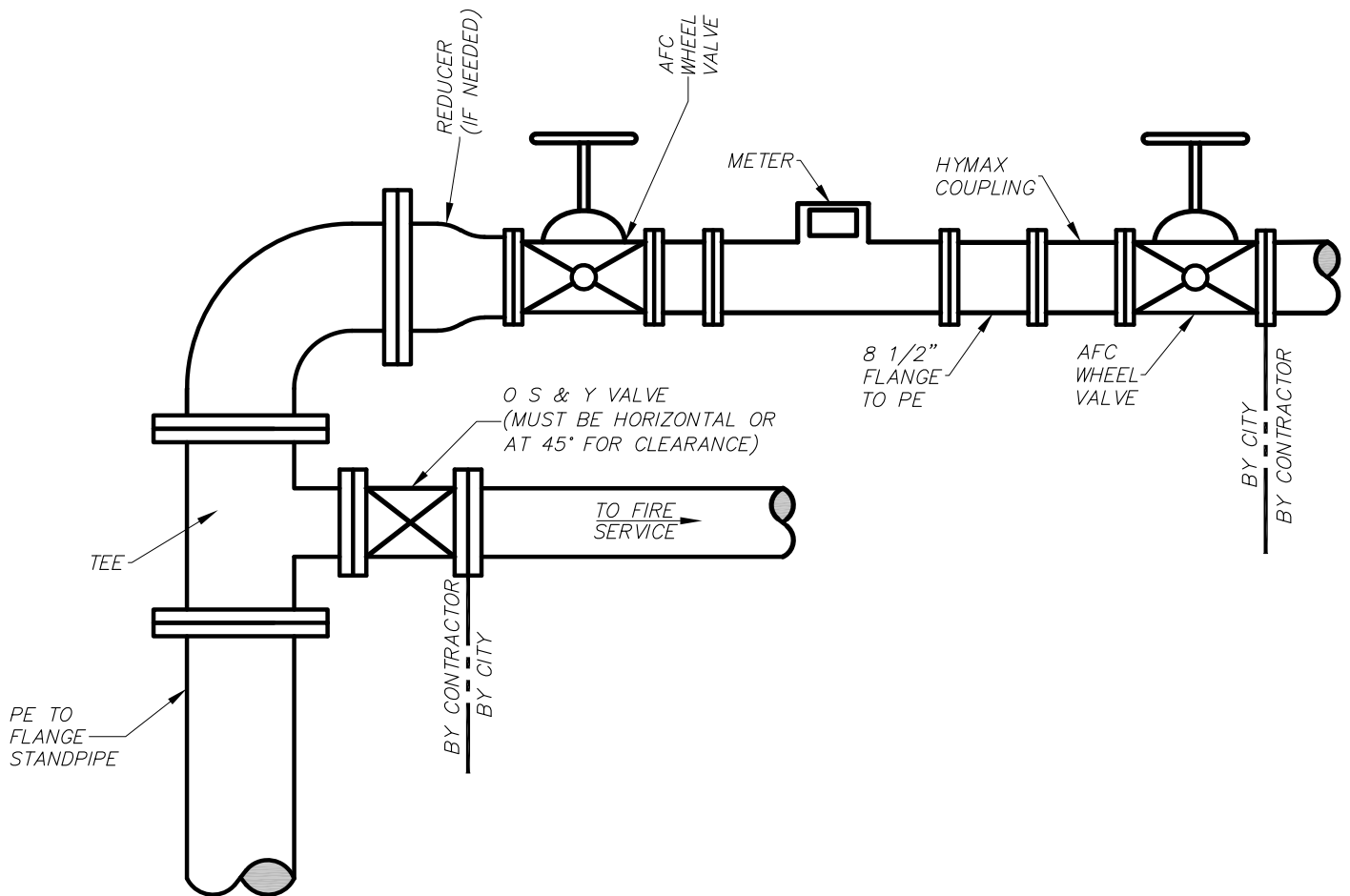

	CITY OF KALAMAZOO Department Of Public Services	RECOMMENDED BY _____ APPROVED BY _____ APPROVED BY _____ ACCEPTED BY _____	DATE
<p align="center"><b>TYPICAL FIRE SERVICE DETAIL                  HORIZONTAL SETTING                  W/3", 4", OR 6" DOMESTIC</b></p>			

WS-16-A

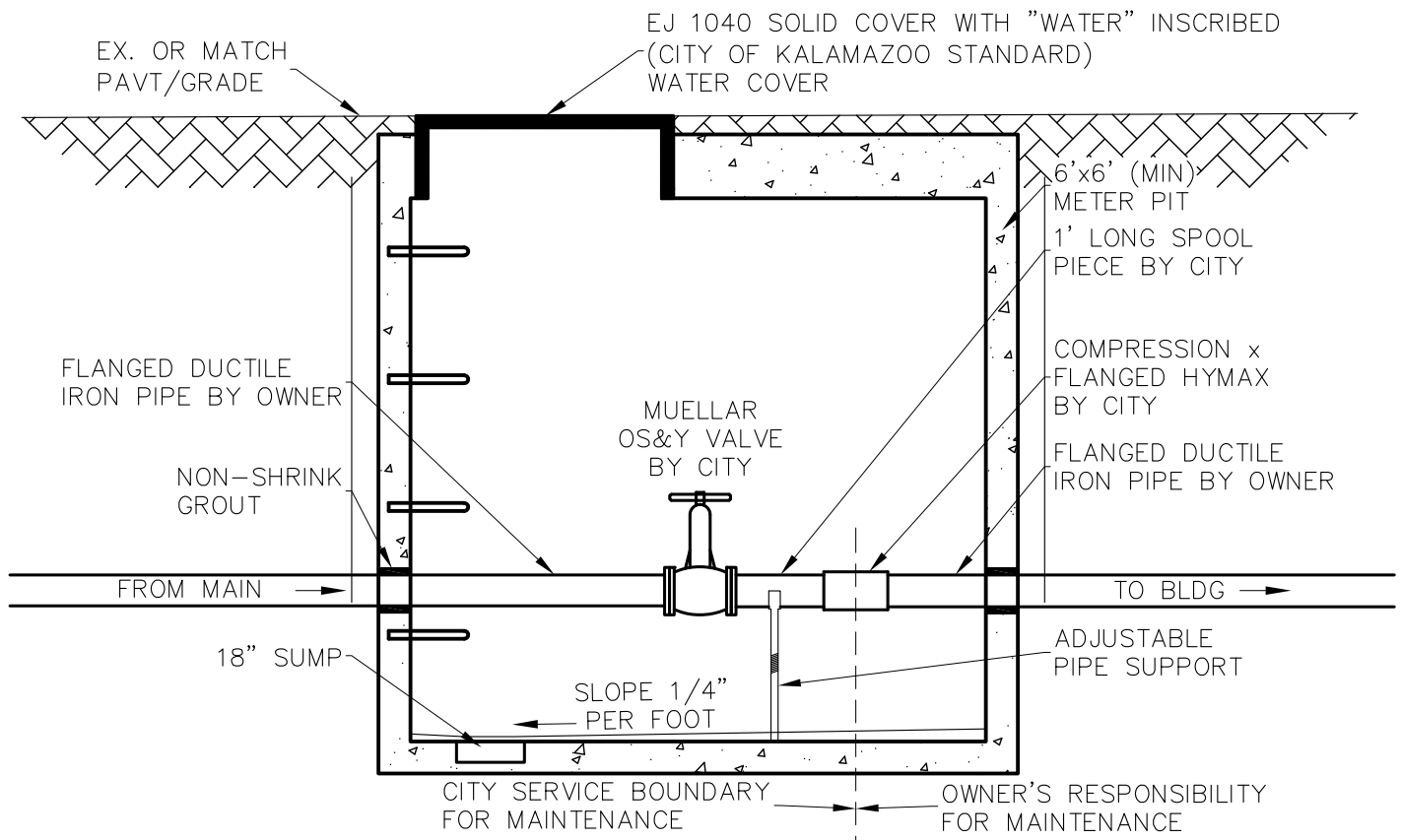
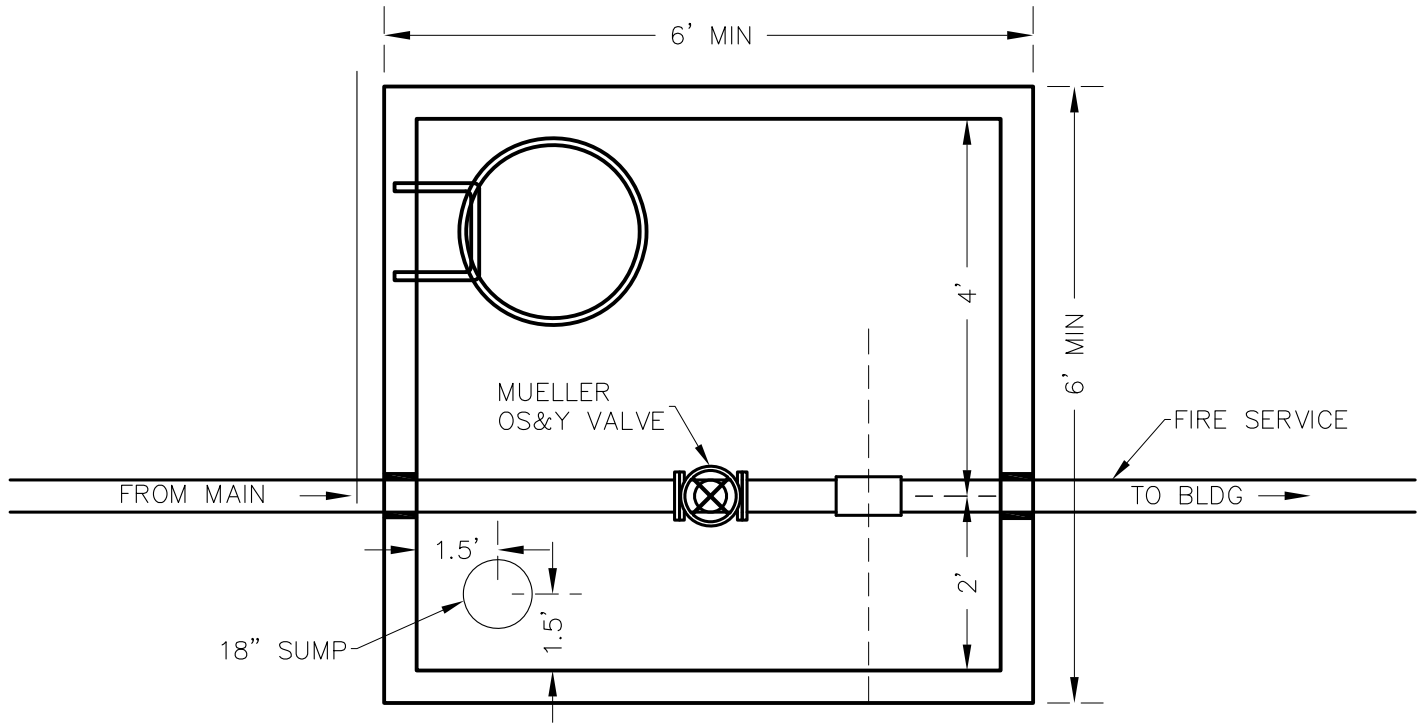

	CITY OF KALAMAZOO Department Of Public Services		DATE
	<b>FIRE SERVICE IN PIT DETAIL</b>		RECOMMENDED BY _____
			APPROVED BY _____
			APPROVED BY _____
			ACCEPTED BY _____