



Department of Management Services
Purchasing Division
241 West South Street
Kalamazoo, MI 49007-4796
Phone: 269.337.8020
www.kalamazoo.org

NON-MANDATORY WALKTHROUGH/SITE INSPECTION

September 15, 2025, 10:00 a.m. to 12:00 p.m.

Location: 150 E. Crosstown Parkway (CPED Side Only)

INVITATION FOR BID (IFB)

The City of Kalamazoo, Michigan is soliciting sealed bids for:

PROJECT NAME: Electrical & Data - Crosstown Parkway Remodel

BID REFERENCE#: 91082-033.0

IFB ISSUE DATE: September 10, 2025

BID DUE/OPENING DATE: September 24, 2025, at 12:00 (Noon) p.m. Local Time

Electronic Bids Will Not Be Accepted.

MAILING ADDRESS & INSTRUCTIONS

Mail to:

Purchasing Division
241 W. South Street
Kalamazoo, MI 49007

Questions about this IFB should be directed to:

Department Contact: **Tyler Dundore, AVB** at
tdundore@avbinc.com.

Include on the Envelope the Project Name and Bid Reference Number. All Envelopes Must Be Sealed.

You are invited to submit a bid for this project. Specifications, terms, conditions and instructions for submitting bids are contained herein. This Invitation for Bid with all pages, documents and attachments contained herein, or subsequently added to and made a part hereof, submitted as a fully and properly executed bid shall constitute the contract between the City and the successful bidder when approved and accepted on behalf of the City by an authorized official or agent of the City. Please review the bid document as soon as possible and note the **DEADLINE FOR QUESTIONS** in the Instructions to Bidders.

All bidders shall complete and return the Bid and Award page(s) and submit all information requested herein in order for a bid to be responsive. The bid document shall be returned in its entirety, in a properly identified and sealed envelope to the Purchasing Division at the above address. **BIDS MUST BE RECEIVED BEFORE THE DUE DATE - LATE BIDS WILL NOT BE CONSIDERED.** The City reserves the right to postpone the bid opening for its own convenience.

TABLE OF CONTENTS

<u>SECTION</u>	<u>PAGE #</u>	<u>APPENDICES</u>
		Appendix A
I	1 - 2	Appendix B
II	3 - 8	Prevailing Wages
III	9 - 10	Attachment 1
IV	11 - 12	Attachment 2
V	13 - 18	Attachment 3
VI	19 - 23	Attachment 4

CITY OF KALAMAZOO – INVITATION FOR BIDS
Electrical & Data - Crosstown Parkway Remodel

Bid Reference #: 91082-033.0

STATEMENT OF NO BID

NOTE: If you DO NOT intend to bid on this commodity or service, please complete and return this form immediately. Your response will assist us in evaluating all responses for this important project and to improve our bid solicitation process.

The Purchasing Division of the City of Kalamazoo wishes to keep its bidders list file up to date. If, for any reason you cannot supply the commodity/service noted in this bid solicitation, this form must be completed and returned to remain on the particular bid list for future projects of this type.

If you do not respond to this inquiry within the time set for the bid opening date and time noted, we will assume that you can no longer supply this commodity/service, and your name will be removed from this bid list.

- _____ Specifications too "tight", i.e. geared toward one brand or manufacturer only (explain below).
- _____ Specifications are unclear (explain below).
- _____ We are unable to meet specifications.
- _____ Insufficient time to respond to the Invitation for Bid.
- _____ Our schedule would not permit us to perform.
- _____ We are unable to meet bond requirements.
- _____ We are unable to meet insurance requirements.
- _____ We do not offer this product or service.
- _____ Remove us from your bidders list for this commodity or service.
- _____ Other (specify below).

REMARKS: _____

SIGNED: _____ NAME: _____
(Type or Print)

TITLE: _____ DATE: _____

FIRM NAME: _____
(if any)

ADDRESS: _____
(Street address) (City) (State) (Zip)

PHONE: _____ EMAIL: _____

**SECTION I
INSTRUCTIONS TO BIDDERS**

1. **EXAMINATION OF BID DOCUMENT**-Before submitting a bid, bidders shall carefully examine the specifications and shall fully inform themselves as to all existing conditions and limitations. The bidder shall indicate in the bid the sum to cover the cost of all items included on the bid form.
2. **PREPARATION OF BID**-The bid shall be legibly prepared in ink or typed. If a unit price or extension already entered by the bidder on the Bid and Award form is to be altered, it shall be crossed out and the new unit price or extension entered above or below and initialed by the bidder with ink. The bid shall be legally signed and the complete address of the bidder given thereon.

All bids shall be tightly sealed in an envelope plainly marked SEALED BID and identified by project name, bid opening date and time. Bids opened by mistake, due to improper identification, will be so documented and resealed. The Purchasing Division will maintain and guarantee confidentiality of the contents until the specified opening date and time. Bids submitted electronically will not be accepted.

3. **EXPLANATION TO BIDDERS**-Any binding explanation desired by a bidder regarding the meaning or interpretation of the Invitation for Bids (IFB) and attachments must be requested in writing, at least 5 business days before the bid opening so a reply may reach all prospective bidders prior to the submission of bids. Any information given to a prospective bidder concerning the IFB will be furnished to all prospective bidders as an amendment or addendum to the IFB if such information would be prejudicial to uninformed bidders. Receipt of amendments or addenda by a bidder must be acknowledged in the bid by attachment, or by letter received before the time set for opening of bids. Oral explanation or instructions given prior to the opening will not be binding.
4. **CASH DISCOUNTS**-Discount offered for payment of less than thirty (30) days will not be considered in evaluating bids for award. Offered discounts of less than thirty (30) days will be taken if payment is made within the discount period, even though not considered in evaluation of the bid.
5. **WITHDRAWAL OF BIDS**-Bids may be withdrawn in person by a bidder or authorized representative, provided their identity is made known and a receipt is signed for the bid, but only if the withdrawal is made prior to the exact time set for receipt of bid. No bid may be withdrawn for at least ninety (90) days after bid opening.
6. **ALTERNATE BIDS**-bidders are cautioned that any alternate bid, unless specifically requested or any changes, insertions or omissions to the terms and conditions, specifications or any other requirement of this IFB may be considered non-responsive, and at the option of the City, result in rejection of the alternate bid.
7. **LATE BIDS**-Any bid received at the office designated herein after the exact time specified for receipt will not be considered. (Note: The City reserves the right to consider bids that have been determined by the City to be received late due to mishandling by the City after receipt of the bid and no award has been made.)
8. **UNIT PRICES**-If there is a discrepancy between unit prices and their extension, unit prices shall prevail.
9. **BID SUBMITTAL**- Bidders can submit sealed bids in one of the following ways:
 - 9.1. **Mail your bid**, to be received before the bid due date and time indicated in the bid document, to the City of Kalamazoo at the following address:

City of Kalamazoo
Purchasing Division
241 West South Street
Kalamazoo, MI 49007

- 9.2. **Deliver your bid to City Hall In-Person** before the bid due date and time indicated in the bid document.
- 9.3. **Deliver your bid to the Treasurer’s Office Payment Drop Box** located in the northwest corner of City Hall (see photos below) before the bid due date and time indicated in the bid document.



1. Open drop box located at City Hall.



2. Insert SEALED BID here.



- 10. **BID TABULATIONS-** The Purchasing Division makes an effort to post bid tabulations to the City of Kalamazoo website within 24 hours after the bid opening date and time at: <https://www.kalamazoo.org/bidopportunities>. However, in certain cases the posting of the bid tabulation may extend beyond the 24-hour window.

SECTION II
BID AND AWARD

The undersigned having become thoroughly familiar with all of the bid/contract documents incorporated herein, the project site and the location conditions affecting the work, hereby proposes to perform everything required to be performed in strict conformity with the requirements of these documents, and to provide and furnish all the equipment, labor and materials necessary to complete in a professional manner the *Electrical & Data - Crosstown Parkway Remodel*, meeting or exceeding the specifications as set forth herein for the prices as stated below.

ELECTRICAL & DATA - CROSSTOWN PARKWAY REMODEL

Furnish all labor, materials, tools, equipment, and services necessary to complete the <i>Electrical & Data - Crosstown Parkway Remodel project</i> as stated in the Scope, Specifications and Drawings.	LS	\$
TOTAL AMOUNT		\$

Work shall start after receipt of notification by Contractor of Notice to Proceed and shall be completed by date listed on the Bid Schedule. **SEE AVB - Bid Schedule - Attachment 2.**

Bidder shall provide all of the information as requested herein with their bid. **Failure to do so and/or failure to provide post-bid requested information may be cause for rejecting the bid as non-responsive.**

Bidder/Contractor has examined and carefully studied the bidding documents and attachments, and acknowledges receipt of the following addenda:

Addendum No: _____

Dated: _____

The City encourages the use of local labor in fulfilling the requirements of this contract.

By my signature below, I certify that the firm bidding on this contract, when making hiring decisions, does not use a past criminal conviction as a bar to or preclude a person with a criminal conviction from being considered for employment with the bidding firm unless otherwise precluded by federal or state law. I further certify that I have read and agree to be bound by the provisions of the City’s Non-Discrimination Clause found in Appendix A and as updated by City Ordinance 1856.

Signed: _____ Name: _____

Title: _____

CITY OF KALAMAZOO EX-OFFENDER POLICY CHECKLIST

As part of the City’s commitment to reducing unacceptable poverty, encouraging rehabilitation, reducing recidivism and strengthening families in Kalamazoo, the City has updated its Purchasing Policy to ensure that firms with whom the City does business share in this commitment by utilizing hiring practices that do not unfairly deny people with arrest and conviction records gainful employment. *(Important: This requirement also extends to any subcontractors the bidder intends to use to fulfill the contract for goods or services being sought from the City.)*

Part I: Proof that the bidder does not inquire about an individual’s past arrest or criminal history on the bidders employment application form

- Attach a copy of the current application for employment being used by the bidder

Part II: Certification that the bidder does not use an individual’s past arrest or criminal history to unlawfully discriminate against them by checking *one or more* of the following:

- That pursuant to federal or state law bidder is precluded from hiring persons with certain criminal records from holding particular positions or engaging in certain occupations by providing a cite to the applicable statute or regulation; if checking this box, provide a citation to the applicable statute or rule upon which the bidder is relying:_____
- That bidder conducts criminal history background checks only as necessary, and only after making a conditional offer of employment; that any withdrawal of an offer of employment to an individual because of a past criminal history is job-related and consistent with business necessity after the individual has been provided an individualized assessment opportunity to review and challenge or supplement the history of past criminal conduct being relied upon by the bidder;
- That the use by bidder of criminal history background checks complies with the U.S. Equal Employment Opportunity Commission’s Enforcement Guidance on the Consideration of Arrest and Conviction Records in Employment Decisions and that the bidder has not had a determination rendered against it in past 7 years that it discriminated against a person through the use of an individual’s arrest or criminal history

I CERTIFY THAT THE ABOVE STATEMENTS ARE TRUE.

Date

Signature

Printed Name

Position

CITY OF KALAMAZOO
LOCAL PREFERENCE POLICY AND CERTIFICATION

The lowest responsive Kalamazoo County bidder whose bid is not low but falls within 2% of the lowest responsive bid is afforded the opportunity to become the successful bidder if it agrees to reduce its bid to match the lowest responsive bid. The City of Kalamazoo is the sole determiner whether a bidder is responsible, qualifies as a Kalamazoo County bidder, and if its bid is responsive to the City’s specifications, terms and conditions.

If the lowest Kalamazoo County bidder chooses not to match the lowest bid, the next lowest responsive Kalamazoo County bidder, whose bid falls within 2% of the lowest bid, is given the opportunity to match the lowest responsive bid.

To qualify as a Kalamazoo County bidder, the bidder must meet both the following criteria:

1. Have a physical presence in Kalamazoo County by maintaining a permanent office, factory or other facility in Kalamazoo County with employees working in Kalamazoo County.
2. Have paid real or personal property taxes related to said business to the City of Kalamazoo, County of Kalamazoo, or other municipal corporation within Kalamazoo County in the previous tax year, except that a non-profit entity need not meet this requirement.

This local preference policy applies only to purchases for materials, supplies, capital outlay, and services for maintenance, repair or operation of City facilities that are over \$25,000. If more than 50% of the contract is sub-contracted to firms located outside of Kalamazoo County that bid does not qualify for the local preference policy outlined above. The local preference policy will not apply if prohibited by law. The Purchasing Agent has the authority to finally determine if the bidder qualifies as a Kalamazoo County bidder as set forth herein. The Purchasing Agent may take into account the permanency of the business in Kalamazoo, and whether the business appears to be claiming to be a Kalamazoo County business solely or primarily to qualify as a Kalamazoo County business under this Resolution, and any other material factors.

CERTIFICATION

If you qualify as a Kalamazoo County bidder and wish to be considered for the local preference provisions as provided above, please certify that fact by providing the information requested below and attesting to its accuracy.

Firm Name: _____

Street Address of Business: _____

City, State, and Zip Code: _____

Number of employees working in Kalamazoo County: _____

Name the city or township to which business real and/or personal property taxes are paid or provide non-profit status:

The above information is accurate:

Signature: _____

Date: _____

Title: _____

REFERENCE QUESTIONNAIRE

Please answer the following questions completely.

1. Firm name: _____
2. Established: Year _____ Number of Employees: _____
3. Type of organization:
 - a. Individual: _____
 - b. Partnership: _____
 - c. Corporation: _____
 - d. Other: _____
4. Former firm name(s) if any, and year(s) in business:

5. Include at least 3 references of contracts for similar work performed over the last five (5) years. Include: owner, contact person and phone number and description of work performed.
 - 5.1 Company Name: _____
Address: _____
Phone: _____
Contact: _____
Type of work or contract: _____
 - 5.2 Company Name: _____
Address: _____
Phone: _____
Contact: _____
Type of work or contract: _____
 - 5.3 Company Name: _____
Address: _____
Phone: _____
Contact: _____
Type of work or contract: _____

I hereby certify that all of the information provided is true and answered to the best of my ability.

Signed: _____ Name: _____
(type or print)

Title: _____ Date: _____

I hereby state that all of the information I have provided is true, accurate and complete. I hereby state that I have the authority to submit this bid which will become a binding contract if accepted by the City of Kalamazoo. I hereby state that I have not communicated with nor otherwise colluded with any other bidder, nor have I made any agreement with nor offered/accepted anything of value to/from an official or employee of the City of Kalamazoo that would tend to destroy or hinder free competition.

The firm's identification information provided will be used by the City for purchase orders, payment and other contractual purposes. If the contractual relationship is with, or the payment made to, another firm please provide a complete explanation on your letterhead and attach to your bid. Please provide for accounts payable purposes:

Tax Identification Number (Federal ID): _____

Remittance Address: _____

Financial Contact Name: _____ Financial Contact Phone Number: _____

Financial Contact Email Address: _____

I hereby state that I have read, understand, and agree to be bound by all terms and conditions of this bid document.

SIGNED: _____ NAME: _____
(Type or Print)

TITLE: _____ DATE: _____

FIRM NAME: _____
(if any)

ADDRESS: _____
(Street address) (City) (State) (Zip)

PHONE: _____ EMAIL ADDRESS: _____

FOR CITY USE ONLY - DO NOT WRITE BELOW

**SECTION III
CITY OF KALAMAZOO
INDEMNITY AND INSURANCE**

Contractor, or any of their subcontractors, shall not commence work under this contract until they have obtained the insurance required under this paragraph, and shall keep such insurance in force during the entire life of this contract. All coverage shall be with insurance companies licensed and admitted to do business in the State of Michigan and acceptable to the City of Kalamazoo within ten (10) days of the Notice of Award. The requirements below should not be interpreted to limit the liability of the Contractor. All deductibles and SIR's are the responsibility of the Contractor.

The Contractor shall procure and maintain the following insurance coverage:

Workers' Compensation Insurance including Employers' Liability Coverage, in accordance with all applicable statutes of the State of Michigan.

Commercial General Liability Insurance on an "Occurrence Basis" with limits of liability not less than \$1,000,000 per occurrence and aggregate. Coverage shall include the following extensions: (A) Contractual Liability; (B) Products and Completed Operations; (C) Independent Contractors Coverage; (D) Broad Form General Liability Extensions or equivalent, if not already included and (E) XCU coverage if the nature of the contract requires XC or U work.

Automobile Liability including Michigan No-Fault Coverages, with limits of liability not less than \$1,000,000 per occurrence, combined single limit for Bodily Injury, and Property Damage. Coverage shall include all owned vehicles, all non-owned vehicles, and all hired vehicles.

Additional Insured: Commercial General Liability and Automobile Liability, as described above, shall include an endorsement stating that the following shall be *Additional Insureds*: The City of Kalamazoo, all elected and appointed officials, all employees and volunteers, all boards, commissions, and/or authorities and board members, including employees and volunteers thereof. It is understood and agreed that by naming the City of Kalamazoo as additional insured, coverage afforded is considered to be primary and any other insurance the City of Kalamazoo may have in effect shall be considered secondary and/or excess.

To the fullest extent permitted by law the Contractor agrees to defend, pay on behalf of, indemnify, and hold harmless the City of Kalamazoo, its elected and appointed officials, employees, agents and volunteers, and others working on behalf of the City of Kalamazoo against any and all claims, demands, suits, or loss, including all costs connected therewith, and for any damages which may be asserted, claimed, or recovered against or from the City of Kalamazoo, by reason of personal injury, including bodily injury or death and/or property damage, including loss of use thereof, which arises out of, or is in any way connected or associated with this contract.

Cancellation Notice: All policies, as described above, shall include an endorsement stating that it is understood and agreed that thirty (30) days, or ten (10) days for non-payment of premium, Advance Written Notice of Cancellation, Non-Renewal, Reduction, and/or Material Change shall be sent to: City of Kalamazoo, Purchasing Department, 241 W. South Street, Kalamazoo, MI 49007.

Proof of Insurance Coverage: The Contractor shall provide the City of Kalamazoo at the time that the contracts are returned by him/her for execution, or within 10 days of Notice of Award, whichever is earlier, a Certificate of Insurance as well as the required endorsements. In lieu of required endorsements, if applicable, a copy of the policy sections where coverage is provided for additional insured and cancellation notice would be acceptable. Copies or certified copies of all policies mentioned above shall be furnished, if so requested.

INDEMNITY AND INSURANCE
Continued

If any of the above coverages expire during the term of this contract, the Contractor shall deliver renewal certificates and/or policies to City of Kalamazoo at least ten (10) days prior to the expiration date.

Scope of Coverage: The above requirements and conditions shall not be interpreted to limit the liability of the Contractor under this Contract but shall be interpreted to provide the greatest benefit to the City and its officers and employees. The above listed coverages shall protect the Contractor, its employees, agents, representatives, and subcontractors against claims arising out of the work performed. It shall be the Contractor's responsibility to provide similar insurance for each subcontractor or to provide evidence that each subcontractor carries such insurance in like amount prior to the time such subcontractor proceeds to perform under the contract.

SECTION IV
SPECIAL REQUIREMENTS

1. BID BOND/GUARANTEE

The bid must be accompanied by a bid bond which shall not be less than five (5%) percent of the total amount of the bid. No bid will be considered unless it is accompanied by the required guarantee. The bid guarantee shall ensure the execution of the bid and award, and the furnishing of a performance bond and a labor and material bond (A and B below) by the successful bidder. (Contractors Note: A cashier's or certified check in lieu of a bid bond is **NOT** acceptable.)

A. PERFORMANCE BOND

A performance bond shall be furnished in the full amount of the contract ensuring the City of faithful performance of all the provisions of the contract, and the satisfactory performance of any equipment required hereunder. The bond shall also ensure the City against defective workmanship and/or materials.

B. LABOR AND MATERIAL (PAYMENT) BOND

A labor and material (payment) bond shall be furnished for the period covered by the contract, in the full amount of the contract for the protection of labor and material suppliers and sub-contractors.

Bonds shall be secured by a guaranty, or a surety company listed in the latest issue of the U.S. Treasury, circular 570, and licensed to do business in the State of Michigan and written in favor of the City of Kalamazoo. The amount of such bonds shall be within the maximum amount specified for such company in said circular 570. The bonds shall be accompanied by a power of attorney showing authority of the bonding agent to sign such bonds on behalf of the guaranty or surety company. The cost of the bonds shall be borne by the Contractor.

Failure of the Contractor to supply the required bonds within ten (10) days after Notice of Award, or within such extended period as the Purchasing Agent may agree to, shall constitute a default and the City of Kalamazoo may either award this contract to the next lowest bidder or re-advertise for bids and may charge against the Contractor for the difference between the amount of the bid and the amount for which a contract for the work is subsequently executed, irrespective of whether the amount thus due exceeds the amount of the bid bond. If a more favorable bid is received by re-advertising, the defaulting bidder shall have no claim against the City of Kalamazoo for a refund.

2. WAIVERS OF LIEN

Upon completion of all work and request for final payment, the Contractor shall furnish a 100% waiver of lien from each supplier and sub-contractor covering all items of the work. Failure to supply waivers of lien for the entire job upon completion and final payment request will be considered grounds for withholding final payment.

3. SUBCONTRACTORS

- A. Contractors shall state on the Bid and Award page any and all subcontractors to be associated with their bid, including the type work to be performed. Any and all subcontractors shall be bound by all of the terms, conditions and requirements of the contract; however, the prime contractor shall be responsible for the performance of the total work requirements.
- B. The Contractor shall cooperate with the City of Kalamazoo in meeting its commitments and goals with regard to maximum utilization of minority and women business enterprise and shall use its best efforts to ensure that minority and women business enterprises have maximum practicable opportunity to compete for subcontract work under this agreement.

4. PREVAILING WAGES

The successful bidder will be required to comply with Section 2-125 of the Code of Ordinances of the City of Kalamazoo regarding prevailing wages and Appendix B attached, incorporated herein by reference. Special note: This provision applies only to projects in excess of \$100,000 for City (\$2,000 federal) funded projects.

The City's requirements as it relates to prevailing wages includes a meeting with the City's Purchasing Division **prior** to work and payroll and work monitoring to be reported in LCPtracker during the duration of the contract. Please contact Purchasing at (269) 337-8020 if you have any questions regarding Davis-Bacon provisions.

SECTION V
GENERAL PROVISIONS

1. INTENT

It is the intent of these specifications and drawings/plans to provide for a contractor who shall provide all labor, materials, tools, equipment, and services necessary to perform in a professional manner the *Electrical & Data for the Crosstown Parkway Remodel* as described in the specifications and bid document.

2. SCOPE OF WORK

The scope of work involves work for *Electrical & Data for the Crosstown Parkway Remodel* as stated in the attached scope, specifications and drawings.

3. QUANTITIES

The quantities shown or indicated on the specifications are only estimated. Payment will be made based upon unit pricing of quantities installed.

4. UNIT PRICING

The unit price, including its pro-rata share of overhead, multiplied by the quantity shown shall represent the total bid and shall be held firm for the life of this contract. Any bid not conforming to this requirement may be rejected as non-responsive.

5. INSPECTION OF WORK

The City may maintain inspectors on the job who shall at all times have access to work.

6. INSPECTION OF SITE

Each bidder shall visit the site of the proposed work and fully acquaint himself/herself with the existing conditions relating to construction and labor and shall fully inform himself/herself as to the facilities involved and the difficulties and restrictions attending the performance of this contract. The bidder shall thoroughly examine and become familiar with the drawings, specifications and all other bid/contract documents. The Contractor, by the execution of this contract, shall in no way be relieved of any obligation under it due to his/her failure to receive or examine any form or legal instrument, or to visit the site and acquaint himself/herself with the conditions there existing. No allowance shall be made subsequently in this connection on behalf of the Contractor for any negligence of his/her part. Any questions contact Tyler Dundore, AVB at tdundore@avbinc.com.

7. INSPECTION AND TESTING

The Contractor shall give the Project Manager timely notice of readiness of the work for all required inspections, tests or approvals, and shall cooperate with inspections and testing personnel to facilitate required inspections or tests. The City will provide for materials and construction testing including but not limited to compaction of subbase and backfill material, concrete testing and asphalt testing. The cost of said testing shall be borne by the City. Verification that testing required by the contract has been completed on one phase of the project prior to proceeding to the next phase is the responsibility of the Contractor. In the event that the project has proceeded without required testing, the Contractor shall insure that the required testing is obtained retroactively and shall provide access for testing as necessary at his/her sole expense.

8. MATERIALS INSPECTION AND RESPONSIBILITY

- 8.1 The Project Manager shall have the right to inspect any materials to be used in carrying out the terms of the contract.
- 8.2 The City does not assume any responsibility for the contracted quality and standard of all materials, equipment, components or completed work furnished under this contract.
- 8.3 Any materials, equipment, components or completed work which does not comply with contract specifications, MDOT, or State codes may be rejected by the City, and shall be replaced by the Contractor at no cost to the City.
- 8.4 Any materials, equipment or components rejected shall be removed within a reasonable period of time from the premises of the City at the entire expense of the Contractor after notice has been given by the City to the Contractor that such materials, equipment or components have been rejected.

9. LAYING OUT WORK

Before submitting a bid, the Contractor shall verify all measurements and shall be responsible for the correctness of same. No extra charge or compensation will be allowed on account of differences between actual dimensions and the measurements indicated on the drawings. Any difference that may be found shall be submitted to the Citywide Facilities Manager for consideration before proceeding. The Citywide Facilities Manager Engineer will provide direction as needed.

10. SUPERVISION

The Contractor shall employ an experienced superintendent or foreperson on the job at all times.

11. SITE SECURITY

The Contractor shall be responsible for job site security of all materials and tools provided by him/her and no claim for loss or damage will be considered by the City.

12. TARDINESS

Construction delays resulting from tardiness on the part of the Contractor will be reviewed by the City in the event of any request for contract extension by the Contractor.

13. PROGRESS SCHEDULE

- 13.1 Work shall start after receipt of notification by Contractor of Notice to Proceed and shall be completed by date listed on the Bid Schedule. ***SEE AVB - Bid Schedule - Attachment 2.***
- 13.2 Work of a similar nature may be added to this contract if agreed to by the City and the Contractor. In the event that work is added, the progress schedule for the work will remain unchanged. Any contract time added for additional work will be applied to that additional work only and cannot be added to items in the original contract. Any work done on the items in the original contract past the number of working days stated herein will be subject to liquidated damages regardless of any work that may be added at a later date.

- 13.3 The Contractor will be required to meet with the AVB representatives to work out detailed progress schedule. The schedule for this meeting will be within two weeks after contract award has been made.
- 13.4 The named sub-contractor(s) for all items shall also be present at the scheduled meeting and they will be required to sign the Progress Schedule to indicate their approval of the scheduled dates of work set forth in the Progress Schedule.
- 13.5 The Progress Schedule shall include, as a minimum, the starting and completion dates for major items, and where specified in the bid document the date the project is to be opened to traffic as well as the final project completion date specified in the bid documents. The Progress Schedule shall be coordinated with all aspects of the work occurring at the site.
- 13.6 Failure on the part of the Contractor to carry out the provisions of the Progress Schedule as established may be considered sufficient cause to prevent bidding future projects until a satisfactory rate of progress is again established.
- 13.7 The starting date and the contract time to the completion date for this project may be adjusted by AVB without imposing liquidated damages upon the receipt of satisfactory documented evidence that unforeseen delayed delivery of critical materials will prevent the orderly prosecution of the work.

14. CONSTRUCTION SCHEDULE AND COORDINATION

- 14.1 The Contractor shall supply the City with an agreeable construction schedule before commencing work on this contract. This schedule shall detail beginning and completion dates for each major component of the project.
- 14.2 The Contractor shall coordinate and cooperate with all other contractors who may be working on the site in order to allow for the orderly progress of work being done.
- 14.3 The Contractor is required to keep the Project Manager fully informed of any proposed work which will tend to interfere with the existing operations at the site.
- 14.4 The Contractor shall schedule all work to accommodate the City's schedule. In the event Contractor's schedule falls on weekends, nights or overtime work is required, no additional compensation will be allowed. All work shall be part of this contract without regard to when it is done.

15. CONTRACTOR COORDINATION

- 15.1 The Contractor shall make every effort to coordinate every aspect of his work with that of other contractors on the site to assure an efficiently managed and proper installation.
- 15.2 Consideration shall be given to timing of construction, maintaining adequate construction access, and construction staging. Any costs associated with this coordination shall be included in the contract.

16. ADDITIONS

- 16.1 Any modification to the contract shall be subject to prior approval by the Purchasing Agent. City Commission approval may also be required.
- 16.2 Prices for additional work required are not requested in the itemized listing contained herein for the base project. Should additional work be authorized, compensation shall be made on the basis of price or prices to be mutually agreed upon. Such additional work shall not begin until a Change Order has been approved.

17. REMOVAL OF RUBBISH

The Contractor shall daily remove all rubbish and accumulated materials due to his/her construction.

18. SITE ACCESS

The City will provide fair and reasonable access to the job site within the working schedules of both parties.

19. GUARANTEE

The Contractor shall guarantee all of his/her work for a period of one (1) year following the date of final acceptance of the completed work and shall repair, replace or make good any materials or work which fail to function or perform or be found defective, without cost to the City.

20. SAFETY

The Contractor shall comply with all applicable OSHA and MIOSHA regulations.

21. PAY ESTIMATES

The Contractor shall be responsible for the generation of invoices for payment. Contractors shall use One-Drive Project Spreadsheet. Payment will be generated by the City based upon an approved invoice. Recommended frequency of payment is monthly, however, frequency of payment will not exceed bi-weekly.

22. PRODUCT/SYSTEM SUBSTITUTIONS

Submit a written request, to be received not later than 10 days prior to scheduled bid opening, for Substitution of any Product not named. If no substitutions are submitted, it will be reasonably concluded by the Owner that the specified product will be incorporated into the Work and the Bidder will be committed to supplying the specified product.

22.1 Describe in detail any variance to the specified product. All proposed substitution for specified items shall be substantially the same size (height, length, width, diameter, etc.), type, color, construction quality and shall meet the design intent to be considered for substitution for the Product specified.

22.2 Document each request with complete data substantiating compliance of proposed Substitution with Product specified including written certification that Product conforms to or exceeds all requirements of the Product specified.

22.3 Document all coordination information, including a list of changes or modifications needed to the Contract Documents or other parts of the Work and to construction performed by the Owner and Separate Contractors that will become necessary to accommodate the proposed substitution.

22.4 Provide name, address and telephone number of manufacturer's authorized representative.

22.5 Submit three copies of all documents for each request for Substitution for consideration.

22.6 Approval of the Substitution request, if given, will be in the form of an addendum issued prior to scheduled opening date and hour at local time.

23. SAMPLES AND DEMONSTRATIONS

Evidence in the form of samples may be requested. Such samples are to be furnished after the date of bid opening only upon request of The City unless otherwise stated in the bid proposal. If samples should be requested, such samples must be received by The City no later than seven (7) days after formal request is made. When required, The City may request full demonstrations of any unit(s) bid prior to the award of any contract. Samples, when requested, must be furnished free of expense to The City and if not used in testing or destroyed, will upon request within thirty (30) days of bid award be returned at the bidder's request.

24. ACCEPTANCE OF MATERIAL

The material delivered under this proposal shall remain the property of the seller until a physical inspection and actual usage of the material and/or services is made and thereafter accepted to the satisfaction of The City and must comply with the terms herein and be full in accord with specifications and of the highest quality. In the event the material and/or service supplied to The City is found to be defective or does not conform to specifications, The City reserves the right to cancel the order upon written notice to the seller and return the product to seller at the seller's expense.

25. VARIATIONS TO SPECIFICATIONS

For purposes of evaluation, the bidder **MUST** indicate any variances from our specifications, terms and/or conditions, no matter how slight. If variations are not stated in the proposal, it will be assumed that the product or service fully complies with our specifications, terms and conditions.

26. SAFETY STANDARDS

The bidder warrants that the products supplied to The City conform in all respects to the standards set forth in the Occupational Safety and Health Act of 1970 and its amendments and the failure to comply with this condition will be considered a breach of contract.

27. MANUFACTURER'S CERTIFICATION

The City reserves the right to request from bidders separate manufacturer certification of all statements made in the bid.

28. PROTECTION OF WORK

The Contractor shall maintain adequate protection of all his/her work from damage and shall protect all public and private abutting property from injury or loss arising in connection with this contract.

29. PROTECTION OF PROPERTY

29.1 The Contractor shall confine his/her equipment and operations to those areas of the work site necessary for the completion of the work, or as authorized by the Project Manager. The Contractor shall protect and preserve from damage any facilities, utilities or features including trees, shrubs and turf which are not required to be disturbed by the requirements of the work.

29.2 The Contractor shall be responsible to determine the location of and to protect from damage any utilities or other improvements.

30. **WORK HOURS**

All work shall be done between the hours of 6:30 a.m. to 5:00 p.m. (Monday – Friday). Work done outside of these times will be at the discretion of the Project Manager.

No work shall be done on Saturday or Sunday, unless otherwise approved by the Project Manager in writing.

No work shall be done on City Holidays, unless otherwise approved by the Project Manager in writing.

The Contractor shall conduct their work in such a manner that no excavations are left open overnight. If this is not possible, the Contractor shall provide and install a temporary fence to protect the excavation at the Contractor's expense.

31. **PROJECT MANAGER'S STATUS**

The City Engineer (Engineer) or his/her duly authorized representative shall be the City's Project Manager and shall have the duties and responsibilities as provided in the contract.

The Project Manager shall have the authority to reject any work or materials which do not conform to the contract and to decide questions or interpretations which may arise from the contract documents.

The Contractor shall immediately report to the Project Manager any questionable or obvious error or omission which may be apparent in the contract documents and shall not proceed with work until the Project Manager has resolved the error or omission.

32. **NON-MANDATORY WALKTHROUGH AND SITE INSPECTION**

Each bidder shall also visit the site of the proposed work and fully acquaint himself/herself with the existing conditions relating to construction and labor and shall fully inform himself/herself as to the facilities involved and the difficulties and restrictions attending the performance of this contract. Questions may be emailed to Tyler Dundore, AVB at tdundore@avbinc.com by 10:00 a.m. on September 16, 2025.

The bidder shall thoroughly examine and become familiar with the drawings, specifications and all other bid/contract documents. The Contractor, by the execution of this contract, shall in no way be relieved of any obligation under it due to his/her failure to receive or examine any form of legal instrument, or to visit the site and acquaint himself/herself with the conditions there existing. No allowance shall be made subsequently in this connection in behalf of the Contract for any negligence of his/her part.

33. **QUESTIONS**

Bidders shall address questions regarding the specifications to Tyler Dundore, AVB at tdundore@avbinc.com (This does not relieve the requirements of Page 1, Item 3.). Questions regarding terms, conditions and other related bid requirements may be addressed to Kyle Dunn, Buyer at dunnk@kalamazoo.org or (269) 337-8720.

SECTION VI
TERMS AND CONDITIONS

1. **AWARD OF CONTRACT**

- A. This contract will be awarded to that responsible bidder whose bid, conforming to this solicitation, will be most advantageous to the City, price and other factors considered. The City reserves the right to accept or reject any or all bids and waive informalities and minor irregularities in bids received. Other factors include, as an example but not limited to, delivery time, conformance to specifications, incidental costs such as demurrage and deposits, etc.

Notification of award will be in writing by the Purchasing Agent. Upon notification, the Contractor shall submit to the Purchasing Division all required insurance certificates (if required) and such other documentation as may be requested or required hereunder. Upon their receipt and subsequent approval by the City, the Purchasing Agent will forward to the Contractor a written **NOTICE TO PROCEED**. Work shall **NOT** be started until such **NOTICE TO PROCEED** is received by the Contractor.

- B. Unilateral changes in bid prices by the bidder shall not be allowed. However, the City, at its sole option, reserves the right to negotiate with bidders in the event of, but not limited to:
- 1) No bids received;
 - 2) A single bid being received; or
 - 3) Prices quoted are over budget and/or unreasonable.

2. **COMPLETE CONTRACT**

This bid document together with its addenda, amendments, attachments and modifications, when executed, becomes the complete contract between the parties hereto, and no verbal or oral promises or representations made in conjunction with the negotiation of this contract shall be binding on either party.

3. **SUBCONTRACTORS – NON-ASSIGNMENT**

Bidders shall state in writing any and all sub-contractors to be associated with this bid, including the type of work to be performed. The Contractor shall cooperate with the City of Kalamazoo in meeting its commitments and goals with regard to maximum utilization of minority and women-owned business enterprises.

The Contractor hereby agrees and understands that the contract resulting from this solicitation shall not be transferred, assigned or sublet without prior written consent of the City of Kalamazoo.

4. **TAXES**

The City of Kalamazoo is exempt from all federal excise tax and state sales and use taxes.

5. **INVOICING**

All original invoice(s) will be sent to the Financial Services Division, 241 W. South Street, Kalamazoo, MI 49007 or via email at apinvoice@kalamazoo.org. The Finance Division processes payments after receipt of an original invoice from the Contractor and approval by the department. The City of Kalamazoo's policy is to pay invoice(s) within 30 days from the receipt of the original invoice, if the services or supplies are satisfactory and the proper paperwork and procedures have been followed. **In order to guarantee payment to the vendor on a timely basis, the vendor needs to receive a purchase order number before supplying the City of Kalamazoo with goods or services.** All original, and copies of original invoice(s), will clearly state which purchase order they are being billed against.

INVOICING (Cont.)

The City of Kalamazoo is a government municipality and therefore is tax exempt from all sales tax.

The vendor is responsible for supplying the Finance Division with a copy of their W9 if they are providing a service to the City of Kalamazoo.

6. PAYMENTS

Upon issuance of certificates of Payment by the Architect/Engineer for labor and material incorporated in the work and the materials suitably stored at the site payment shall be made up to ninety (90%) percent of the value thereof.

When the cumulative total of payment is equal to fifty (50%) percent of the contract sum, subsequent payments will be made in the full amount for labor and material certified by the Architect/Engineer.

The amount retained shall be held until final acceptance of the work, receipt of all payrolls, releases, and waiver of liens.

7. CHANGES AND/OR CONTRACT MODIFICATIONS

The City reserves the right to increase or decrease quantities, service or requirements, or make any changes necessary at any time during the term of this contract, or any negotiated extension thereof. Price adjustments due to any of the foregoing changes shall be negotiated and mutually agreed upon by the Contractor and the City.

Changes of any nature after contract award which reflect an increase or decrease in requirements or costs shall not be permitted without prior approval by the Purchasing Agent. City Commission approval may also be required.

ANY CHANGES PERFORMED IN ADVANCE OF PURCHASING AGENT APPROVAL, MAY BE SUBJECT TO DENIAL AND NON-PAYMENT.

8. LAWS, ORDINANCES AND REGULATIONS

The Contractor shall keep himself/herself fully informed of all local, state and federal laws, ordinances and regulations in any manner affecting those engaged or employed in the work and the equipment used. Contractor and/or employees shall, at all times, serve and comply with such laws, ordinances and regulations.

Any permits, licenses, certificates or fees required for the performance of the work shall be obtained and paid for by the Contractor.

This contract shall be governed by the laws of the State of Michigan.

9. RIGHT TO AUDIT

The City or its designee shall be entitled to audit all of the Contractor's records, and shall be allowed to interview any of the Contractor's employees, throughout the term of this contract and for a period of three years after final payment or longer if required by law to the extent necessary to adequately permit evaluation and verification of:

- A. Contractor compliance with contract requirements,
- B. Compliance with provisions for pricing change orders, invoices or claims submitted by the Contractor or any of his payees.

10. HOLD HARMLESS

If the negligent acts or omissions of the Contractor/Vendor or its employees, agents or officers, cause injury to person or property, the Contractor/Vendor shall indemnify and save harmless the City of Kalamazoo, its agents, officials, and employees against all claims, judgments, losses, damages, demands, and payments of any kind to persons or property to the extent occasioned from any claim or demand arising therefrom.

11. DEFAULT

The City may at any time, by written notice to the Contractor, terminate this contract and the Contractor's right to proceed with the work, for just cause, which shall include, but is not limited to the following:

- A. Failure to provide insurance and bonds (when called for), in the exact amounts and within the time specified or any extension thereof.
- B. Failure to make delivery of the supplies, or to perform the services within the time specified herein, or any extension thereof.
- C. The unauthorized substitution of articles for those bid and specified.
- D. Failure to make progress if such failure endangers performance of the contract in accordance with its terms.
- E. Failure to perform in compliance with any provision of the contract.
- F. **Standard of Performance** - Contractor guarantees the performance of the commodities, goods or services rendered herein in accordance with the accepted standards of the industry or industries concerned herein, except that if this specification calls for higher standards, then such higher standards shall be provided.

Upon notice by the City of Contractor's failure to comply with such standards or to otherwise be in default of this contract in any manner following the Notice to Proceed, Contractor shall immediately remedy said defective performance in a manner acceptable to the City. Should Contractor fail to immediately correct said defective performance, said failure shall be considered a breach of this contract and grounds for termination of the same by the City.

In the event of any breach of this contract by Contractor, Contractor shall pay any cost to the City caused by said breach including but not limited to the replacement cost of such goods or services with another Contractor.

The City reserves the right to withhold any or all payments until any defects in performance have been satisfactorily corrected.

In the event the Contractor is in breach of this contract in any manner, and such breach has not been satisfactorily corrected, the City may bar the Contractor from being awarded any future City contracts.

- G. All remedies available to the City herein are cumulative and the election of one remedy by the City shall not be a waiver of any other remedy available to the City.

12. TERMINATION OF CONTRACT

The City may, at any time and without cause, suspend the work of this contract for a period of not more than ninety days after providing notice in writing to the Contractor. The Contractor shall be allowed an adjustment in the contract price or an extension of the contract times, or both, directly attributable to the suspension if Contractor makes an approved claim.

The City may, without prejudice to any other right or remedy of the City, and with or without cause, terminate the contract by giving seven days written notice to the Contractor. In such case the Contractor shall be paid, without duplication, for the following items:

- A. Completed and acceptable work executed in accordance with the contract documents prior to the effective date of termination, including fair and reasonable sums for overhead and profit on such work;
- B. Expenses sustained prior to the effective date of termination in performing services and furnishing labor, materials or equipment as required by the contract documents in connection with uncompleted work, plus fair and reasonable sums for overhead and profit on such expenses;
- C. All documented claims, costs, losses and damages incurred in settlement of terminated contracts with Subcontractors, Suppliers and others; and
- D. Reasonable expenses directly attributable to termination.

The Contractor shall not be paid on account of loss of anticipated profits or revenue or other economic loss arising out of or resulting from such termination.

13. INDEPENDENT CONTRACTOR

At all times, the Contractor, any of his/her employees, or his/her sub-contractors and their subsequent employees shall be considered independent contractors and not as City employees. The Contractor shall exercise all supervisory control and general control over all workers' duties, payment of wages to Contractor's employees and the right to hire, fire and discipline their employees and workers. As an independent contractor, payment under this contract shall not be subject to any withholding for tax, social security or other purposes, nor shall the Contractor or his/her employees be entitled to sick leave, pension benefit, vacation, medical benefits, life insurance or workers' unemployment compensation or the like.

14. PROJECT SUPERVISOR

The Contractor shall employ an individual to act as Project Supervisor. The Project Supervisor shall be available to the Contractor's workers and the Project Manager at all times by use of a beeper or other reliable means. The Project Supervisor shall prepare daily work plans for the employees, monitor employee performance, attendance and punctuality; and work closely with the City's Project Manager in assuring contract compliance.

15. MEETINGS

The Contractor and/or Project Supervisor shall be available to meet with the Department Head or Project Manager at a mutually agreeable time to discuss problems, issues or concerns relative to the contract. Either party may call a meeting at any time. When such a request for a meeting is made, the meeting date shall, in no case exceed five (5) working days after the request; and, if in the sole opinion of the Department Head, the severity of the circumstance warrants, no more than one (1) working day.

16. INSPECTION OF WORK SITE

Before submitting bids or quotes for work, the Contractor shall be responsible for examining the work site and satisfying himself/herself as to the existing conditions under which he/she will be obligated to operate, or that in any way affects the work under this contract. No allowance shall be made subsequently, on behalf of the Contractor, for any negligence on his/her part.

17. CONTRACT PERIOD, EXTENSIONS, CANCELLATION

- A. The contract shall be in effect for the term stated in the specifications.
- B. The City may opt to extend this contract upon mutual agreement of both parties. The number of extensions shall be limited to that stated in the specifications.
- C. The City may, from time to time, find it necessary to continue this contract on a month-to-month basis only, not to exceed a six (6) month period. Such month-to-month extended periods shall be by mutual agreement of both parties, with all provisions of the original contract or any extension thereof remaining in full force and effect.
- D. All contracts, extensions and cost increases are subject to availability of funds and the approval of the City Commission (if required).
- E. The City reserves the right to cancel the contract due to non-appropriation of funds by the City with thirty (30) days written notice.
- F. Either party may terminate the contract (or any extension thereof) without cause at the end of any twelve (12) month term by giving written notice of such intent at least 60 days prior to the end of said twelve (12) month term.
- G. All notices are in effect commencing with the date of mailing. Written notices may be delivered in person or sent by First Class mail or emailed to the last known address.
- H. If cancellation is for default of contract due to non-performance, the contract may be canceled at any time (see Item 11, DEFAULT)

APPENDIX A
NON-DISCRIMINATION CLAUSE FOR ALL CITY OF KALAMAZOO CONTRACTS

The Contractor agrees to comply with the Federal Civil Rights Act of 1964 as amended; the Federal Civil Rights Act of 1991 as amended; the Americans With Disabilities Act of 1990 as amended; the Elliott-Larson Civil Rights Act, Act No. 453, Public Act of 1976 as amended; the Michigan Handicappers Civil Rights Act, Act No. 220, Public Act of 1976 as amended, City Ordinance 1856 and all other applicable Federal and State laws. The Contractor agrees as follows:

1. The Contractor will not discriminate against any employee or applicant for employment because of race, color, religion, national origin, sex, age, height, weight, marital status, physical or mental disability, family status, sexual orientation or gender identity that is unrelated to the individual's ability to perform the duties of the particular job or position. Such action shall include, but not be limited to the following: employment, upgrading, demotion or transfer, recruitment advertising, layoff or termination; rates of pay or other forms of compensations; and selection for training, including apprenticeship.
2. The Contractor will, in all solicitations or advertisements for employees placed by or on behalf of the Contractor, state that all qualified applicants will receive consideration for employment without regard to race, color, religion, national origin, sex, age, height, weight, marital status, physical or mental disability family status, sexual orientation or gender identity that is unrelated to the individuals ability to perform the duties of the particular job or position.
3. If requested by the City, the Contractor shall furnish information regarding practices, policies and programs and employment statistics for the Contractor and subcontractors. The Contractor and subcontractors shall permit access to all books, records and accounts regarding employment practices by agents and representatives of the City duly charged with investigative duties to assure compliance with this clause.
4. Breach of the covenants herein may be regarded as a material breach of the contract or purchasing agreement as provided in the Elliott-Larsen Civil Rights Act and City Ordinance 1856.
5. The Contractor will include or incorporate by reference the provisions of the foregoing paragraphs 1 through 4 in every subcontract or purchase order unless exempted by the rules, regulations or orders of the Michigan Civil Rights Commission* and will provide in every subcontract or purchase order that said provision will be binding upon each subcontractor or seller.
6. The Contractor will not preclude a person with a criminal conviction from being considered for employment unless otherwise precluded by federal or state law. (for contracts over \$25,000)

The Elliott-Larson Civil Rights Act, Sec. 202 of Act. No. 453 of 1976 reads in part as follows:

Sec. 202. (1) An employer shall not:

- (a) Fail or refuse to hire, or recruit, or discharge or otherwise discriminate against an individual with respect to employment, compensation, or a term condition or privilege of employment because of religion, race, color, national origin, age, sex, height, weight or marital status.
- (b) Limit, segregate or classify an employee or applicant for employment in a way which deprives or tends to deprive the employee or applicant of an employment opportunity or otherwise adversely affects the status of an employee or applicant because of religion, race, color, national origin, age, sex, height, weight or marital status.
- (c) Segregate, classify or otherwise discriminate against a person on the basis of sex with respect to a term, condition or privilege of employment, including a benefit plan or system.

* Except for contracts entered into with parties employing less than three employees.

APPENDIX B - PREVAILING WAGES

Prevailing wages are applicable to this contract, therefore, rates will apply as follows:

- (XX) Project is funded by City of Kalamazoo monies and is estimated to be in excess of \$100,000.00. The applicable prevailing wage rates are attached.

Specifications for projects in which the City of Kalamazoo is party for construction, alterations and/or repair including painting and decorating of public buildings or public works in or for the City of Kalamazoo and which requires or involves the employment of mechanics and/or laborers shall contain the following provisions stating the minimum wages to be paid the various classes of laborers and mechanics for the project. Prevailing wage rates determined by the U.S. Department of Labor under Davis Bacon and related acts will be used for City of Kalamazoo construction projects.

By the incorporation of prevailing wage rates within this specification, the City of Kalamazoo stipulates that:

- ✓ Contractor or his/her subcontractor shall pay all mechanics and laborers employed directly upon the site of the work, unconditionally and not less than once a week and without subsequent deduction or rebate on any account the full amount, accrued at the time of payment, computed at wage rates as incorporated herein regardless of any contractual relationship which may be alleged to exist between the contractor or subcontractor and such laborers and mechanics;
- ✓ The scale of wages to be paid shall be posted by the contractor in a prominent and easily accessible place at the site of the work;
- ✓ The Prime Contractor and all subcontractors shall submit weekly certified payrolls documenting the hours worked and wages paid by work classification. **NOTE: Contactor shall not include Social Security numbers of employees on certified payrolls.**
- ✓ There may be withheld from the contractor's accrued payments the amount considered necessary by the City's Contracting Official to pay to laborers and mechanics employed by the contractor or any subcontractor on the work for the difference between the rates of wages required by the contract and the rates of wages received by such laborers and mechanics except those amounts properly deducted or refunded pursuant to the terms of the Davis-Bacon Act (USC, Title 40, Sec. 276a) and interpretations thereof.

Special Note: The City's requirements as it relates to prevailing wages **include a meeting with the City's Purchasing Agent prior to starting work and the submission of weekly certified payrolls by prime contractors and all subcontractors.** The City will monitor certified payrolls, work progress, and conduct interviews with the mechanics and laborers employed directly upon the site during the duration of the contract. Please contact the Purchasing Department at (269) 337-8020 if you have any questions regarding prevailing wage provision.

The overtime pay to which a laborer or mechanic is entitled under this contract shall be that overtime pay to which he/she is entitled by any agreement made with the contractor or subcontractor or by any applicable provision of law; but in no event shall such amount be less than the prevailing wage in the Kalamazoo community for such overtime.

Revised 4-08



PREVAILING WAGES

**Electrical & Data
Crosstown Parkway Remodel**

Bid Reference #: 91082-033.0

September 2025

"General Decision Number: MI20250087 08/29/2025

Superseded General Decision Number: MI20240087

State: Michigan

Construction Type: Building

County: Kalamazoo County in Michigan.

BUILDING CONSTRUCTION PROJECTS (does not include single family homes or apartments up to and including 4 stories).

Note: Contracts subject to the Davis-Bacon Act are generally required to pay at least the applicable minimum wage rate required under Executive Order 14026 or Executive Order 13658. Please note that these Executive Orders apply to covered contracts entered into by the federal government that are subject to the Davis-Bacon Act itself, but do not apply to contracts subject only to the Davis-Bacon Related Acts, including those set forth at 29 CFR 5.1(a)(1).

<p>If the contract is entered into on or after January 30, 2022, or the contract is renewed or extended (e.g., an option is exercised) on or after January 30, 2022:</p>	<ul style="list-style-type: none"> . Executive Order 14026 generally applies to the contract. . The contractor must pay all covered workers at least \$17.75 per hour (or the applicable wage rate listed on this wage determination, if it is higher) for all hours spent performing on the contract in 2025.
<p>If the contract was awarded on or between January 1, 2015 and January 29, 2022, and the contract is not renewed or extended on or after January 30, 2022:</p>	<ul style="list-style-type: none"> . Executive Order 13658 generally applies to the contract. . The contractor must pay all covered workers at least \$13.30 per hour (or the applicable wage rate listed on this wage determination, if it is higher) for all hours spent performing on that contract in 2025.

The applicable Executive Order minimum wage rate will be adjusted annually. If this contract is covered by one of the Executive Orders and a classification considered necessary for performance of work on the contract does not appear on this wage determination, the contractor must still submit a conformance request.

Additional information on contractor requirements and worker protections under the Executive Orders is available at <http://www.dol.gov/whd/govcontracts>.

Modification Number	Publication Date
0	01/03/2025
1	01/24/2025

2	02/21/2025
3	04/04/2025
4	04/11/2025
5	05/23/2025
6	06/06/2025
7	07/04/2025
8	07/18/2025
9	08/08/2025
10	08/22/2025
11	08/29/2025

ASBE0047-002 07/01/2025

	Rates	Fringes
ASBESTOS WORKER/HEAT & FROST INSULATOR.....	\$ 40.00	23.65

BOIL0169-001 07/01/2025

	Rates	Fringes
BOILERMAKER.....	\$ 43.50	36.74

BRMI0009-031 08/01/2024

	Rates	Fringes
BRICKLAYER.....	\$ 35.21	24.26
TILE FINISHER.....	\$ 26.24	21.13
TILE SETTER.....	\$ 27.35	22.20

CARP0525-013 06/01/2023

	Rates	Fringes
CARPENTER (Including Acoustical Ceiling Installation, Drywall Hanging, Form Work, Metal Stud Installation & Scaffold Builder).....	\$ 28.29	21.42

* CARP1102-001 06/01/2025

	Rates	Fringes
MILLWRIGHT.....	\$ 40.04	26.47

ELEC0131-001 06/01/2025

	Rates	Fringes
ELECTRICIAN Excludes Low Voltage Wiring.	\$ 42.78	21.84

ENGI0324-002 06/01/2024

	Rates	Fringes
OPERATOR: Power Equipment		
GROUP 1.....	\$ 47.28	25.25
GROUP 2.....	\$ 43.93	25.25
GROUP 3.....	\$ 42.25	25.25
GROUP 4.....	\$ 39.57	25.25

GROUP 5.....	\$ 39.57	25.25
GROUP 6.....	\$ 33.37	25.25
GROUP 7.....	\$ 31.23	25.25

FOOTNOTES:

Crane operator with main boom and jib 300' or longer: \$1.50 per hour above the group 1 rate.
 Crane operator with main boom and jib 400' or longer: \$3.00 per hour above the group 1 rate.

PAID HOLIDAYS: New Year's Day, Memorial Day, Fourth of July, Labor Day, Thanksgiving Day and Christmas Day.

POWER EQUIPMENT OPERATOR CLASSIFICATIONS

GROUP 1: Crane operator with main boom and jib 400', 300', or 220' or longer.

GROUP 2: Crane operator with main boom and jib 140' or longer, tower crane, gantry crane, whirley derrick

GROUP 3: Backhoe/Excavator/Trackhoe; Crane; Concrete Pump; Grader/Blade; Highlift; Hoist; Loader; Roller; Scraper; Stiff Leg Derrick; Trencher

GROUP 4: Bobcat/Skid Loader; Broom/Sweeper; Fork Truck (over 20' lift)

GROUP 5: Boom Truck (non-swinging)

GROUP 6: Fork Truck (20' lift and under for masonry work)

GROUP 7: Oiler

 IRON0025-005 06/01/2025

	Rates	Fringes
IRONWORKER (REINFORCING).....	\$ 36.55	29.51
IRONWORKER (STRUCTURAL).....	\$ 36.55	29.51

 LAB00355-022 06/01/2025

	Rates	Fringes
LABORER		
Common or General; Grade Checker; Mason Tender - Brick; Mason Tender - Cement/Concrete;		
Sandblaster.....	\$ 27.21	13.45
Pipelayer.....	\$ 20.34	12.85

 PAIN0845-013 06/01/2025

	Rates	Fringes
PAINTER: Brush and Roller.....	\$ 27.07	16.46
PAINTER: Drywall		
Finishing/Taping.....	\$ 27.32	16.72
PAINTER: Spray.....	\$ 27.07	16.56

 PLAS0016-003 04/01/2014

	Rates	Fringes
CEMENT MASON/CONCRETE FINISHER...	\$ 22.31	12.83

* PLUM0357-001 07/01/2025

Excluding Fort Custer

	Rates	Fringes
PIPEFITTER, Includes HVAC Pipe and Unit Installation.....	\$ 43.50	25.40
PLUMBER, Excludes HVAC Pipe and Unit Installation.....	\$ 43.50	25.40

* ROOF0070-002 06/01/2025

	Rates	Fringes
ROOFER.....	\$ 33.98	18.51

SFMI0669-001 01/01/2025

	Rates	Fringes
SPRINKLER FITTER (Fire Sprinklers).....	\$ 41.34	27.39

SHEE0007-010 05/01/2024

	Rates	Fringes
SHEET METAL WORKER (HVAC Duct Installation Only).....	\$ 42.74	21.53

* SUMI2011-012 02/01/2011

	Rates	Fringes
IRONWORKER, ORNAMENTAL.....	\$ 18.48	7.93
LABORER: Landscape & Irrigation.....	\$ 10.38 **	0.50
OPERATOR: Bulldozer.....	\$ 19.68	6.64
OPERATOR: Tractor.....	\$ 19.10	8.48
SHEET METAL WORKER, Excludes HVAC Duct and Unit Installation.....	\$ 23.59	5.66
TRUCK DRIVER: Dump Truck.....	\$ 17.26 **	11.42
TRUCK DRIVER: Lowboy Truck.....	\$ 14.50 **	0.44
TRUCK DRIVER: Tractor Haul Truck.....	\$ 13.57 **	1.18

WELDERS - Receive rate prescribed for craft performing operation to which welding is incidental.

=====

** Workers in this classification may be entitled to a higher minimum wage under Executive Order 14026 (\$17.75) or 13658 (\$13.30). Please see the Note at the top of the wage determination for more information. Please also note that the minimum wage requirements of Executive Order 14026 are not currently being enforced as to any contract or subcontract to which the states of Texas, Louisiana, or Mississippi, including their agencies, are a party.

Note: Executive Order (EO) 13706, Establishing Paid Sick Leave for Federal Contractors applies to all contracts subject to the Davis-Bacon Act for which the contract is awarded (and any solicitation was issued) on or after January 1, 2017. If this contract is covered by the EO, the contractor must provide employees with 1 hour of paid sick leave for every 30 hours they work, up to 56 hours of paid sick leave each year. Employees must be permitted to use paid sick leave for their own illness, injury or other health-related needs, including preventive care; to assist a family member (or person who is like family to the employee) who is ill, injured, or has other health-related needs, including preventive care; or for reasons resulting from, or to assist a family member (or person who is like family to the employee) who is a victim of, domestic violence, sexual assault, or stalking. Additional information on contractor requirements and worker protections under the EO is available at <https://www.dol.gov/agencies/whd/government-contracts>.

Unlisted classifications needed for work not included within the scope of the classifications listed may be added after award only as provided in the labor standards contract clauses (29CFR 5.5 (a) (1) (iii)).

The body of each wage determination lists the classifications and wage rates that have been found to be prevailing for the type(s) of construction and geographic area covered by the wage determination. The classifications are listed in alphabetical order under rate identifiers indicating whether the particular rate is a union rate (current union negotiated rate), a survey rate, a weighted union average rate, a state adopted rate, or a supplemental classification rate.

Union Rate Identifiers

A four-letter identifier beginning with characters other than ""SU"", ""UAVG"", ?SA?, or ?SC? denotes that a union rate was prevailing for that classification in the survey. Example: PLUM0198-005 07/01/2024. PLUM is an identifier of the union whose collectively bargained rate prevailed in the survey for this classification, which in this example would be Plumbers. 0198 indicates the local union number or district council number where applicable, i.e., Plumbers Local 0198. The next number, 005 in the example, is an internal number used in processing the wage determination. The date, 07/01/2024 in the example, is the effective date of the most current negotiated rate.

Union prevailing wage rates are updated to reflect all changes over time that are reported to WHD in the rates in the collective bargaining agreement (CBA) governing the classification.

Union Average Rate Identifiers

The UAVG identifier indicates that no single rate prevailed for those classifications, but that 100% of the data reported for the classifications reflected union rates. EXAMPLE: UAVG-OH-0010 01/01/2024. UAVG indicates that the rate is a weighted union average rate. OH indicates the State of Ohio. The next number, 0010 in the example, is an internal number used in producing the wage determination. The date, 01/01/2024 in the example, indicates the date the wage determination was updated to reflect the most current union average rate.

A UAVG rate will be updated once a year, usually in January, to reflect a weighted average of the current rates in the collective bargaining agreements on which the rate is based.

Survey Rate Identifiers

The ""SU"" identifier indicates that either a single non-union rate prevailed (as defined in 29 CFR 1.2) for this classification in the survey or that the rate was derived by computing a weighted average rate based on all the rates reported in the survey for that classification. As a weighted average rate includes all rates reported in the survey, it may include both union and non-union rates. Example: SUFL2022-007 6/27/2024. SU indicates the rate is a single non-union prevailing rate or a weighted average of survey data for that classification. FL indicates the State of Florida. 2022 is the year of the survey on which these classifications and rates are based. The next number, 007 in the example, is an internal number used in producing the wage determination. The date, 6/27/2024 in the example, indicates the survey completion date for the classifications and rates under that identifier.

?SU? wage rates typically remain in effect until a new survey is conducted. However, the Wage and Hour Division (WHD) has the discretion to update such rates under 29 CFR 1.6(c)(1).

State Adopted Rate Identifiers

The ""SA"" identifier indicates that the classifications and prevailing wage rates set by a state (or local) government were adopted under 29 C.F.R 1.3(g)-(h). Example: SAME2023-007 01/03/2024. SA reflects that the rates are state adopted. ME refers to the State of Maine. 2023 is the year during which the state completed the survey on which the listed classifications and rates are based. The next number, 007 in the example, is an internal number used in producing the wage determination. The date, 01/03/2024 in the example, reflects the date on which the classifications and rates under the ?SA? identifier took effect under state law in the state from which the rates were adopted.

WAGE DETERMINATION APPEALS PROCESS

1) Has there been an initial decision in the matter? This can be:

- a) a survey underlying a wage determination
- b) an existing published wage determination
- c) an initial WHD letter setting forth a position on a wage determination matter

d) an initial conformance (additional classification and rate) determination

On survey related matters, initial contact, including requests for summaries of surveys, should be directed to the WHD Branch of Wage Surveys. Requests can be submitted via email to davisbaconinfo@dol.gov or by mail to:

Branch of Wage Surveys
Wage and Hour Division
U.S. Department of Labor
200 Constitution Avenue, N.W.
Washington, DC 20210

Regarding any other wage determination matter such as conformance decisions, requests for initial decisions should be directed to the WHD Branch of Construction Wage Determinations. Requests can be submitted via email to BCWD-Office@dol.gov or by mail to:

Branch of Construction Wage Determinations
Wage and Hour Division
U.S. Department of Labor
200 Constitution Avenue, N.W.
Washington, DC 20210

2) If an initial decision has been issued, then any interested party (those affected by the action) that disagrees with the decision can request review and reconsideration from the Wage and Hour Administrator (See 29 CFR Part 1.8 and 29 CFR Part 7). Requests for review and reconsideration can be submitted via email to dba.reconsideration@dol.gov or by mail to:

Wage and Hour Administrator
U.S. Department of Labor
200 Constitution Avenue, N.W.
Washington, DC 20210

The request should be accompanied by a full statement of the interested party's position and any information (wage payment data, project description, area practice material, etc.) that the requestor considers relevant to the issue.

3) If the decision of the Administrator is not favorable, an interested party may appeal directly to the Administrative Review Board (formerly the Wage Appeals Board). Write to:

Administrative Review Board
U.S. Department of Labor
200 Constitution Avenue, N.W.
Washington, DC 20210.

=====

END OF GENERAL DECISION"



ATTACHMENT 1

SPECIFICATIONS

**Electrical & Data
Crosstown Parkway Remodel**

Bid Reference #: 91082-033.0

September 2025

PROJECT MANUAL

City of Kalamazoo Crosstown Facility



Prepared by



Intersect Studio, LLC
155 West Michigan Ave, Suite 1508
Kalamazoo, Michigan 49007

Project Address
150 E Crosstown Parkway
Kalamazoo, Michigan 49001

Project Number 23046

TABLE OF CONTENTS

PROCUREMENT AND CONTRACTING REQUIREMENTS GROUP

DIVISION 00 – PROCUREMENT AND CONTRACTING REQUIREMENTS

INTRODUCTORY INFORMATION

000101	PROJECT TITLE PAGE
000107	SEALS PAGE
000110	TABLE OF CONTENTS

SPECIFICATIONS GROUP

GENERAL REQUIREMENTS SUBGROUP

DIVISION 01 - GENERAL REQUIREMENTS

01 2300	ALTERNATES
01 4000	QUALITY REQUIREMENTS

FACILITY CONSTRUCTION SUBGROUP

DIVISION 02 - EXISTING CONDITIONS

02 4119	SELECTIVE DEMOLITION
---------	----------------------

DIVISION 03 - CONCRETE

03 1000	CONCRETE FORMING AND ACCESSORIES
03 2000	CONCRETE REINFORCING
03 3000	CAST-IN-PLACE CONCRETE
03 5300	ARCHITECTURAL CONCRETE
03 6000	POST INSTALLED ANCHORS

DIVISION 04 - MASONRY

04 0120.63	BRICK MASONRY REPAIR
04 2200	CONCRETE UNIT MASONRY
04 4200	EXTERIOR STONE CLADDING

DIVISION 05 - METALS

05 1200	STRUCTURAL STEEL FRAMING
05 3100	STEEL DECKING
05 4000	COLD-FORMED METAL FRAMING
05 7300	DECORATIVE METAL RAILINGS
05 7313	GLAZED DECORATIVE METAL RAILINGS

DIVISION 06 - WOOD, PLASTICS, AND COMPOSITES

06 1000	ROUGH CARPENTRY
06 2023	INTERIOR FINISH CARPENTRY
06 4023	INTERIOR ARCHITECTURAL WOODWORK
06 4100	ARCHITECTURAL WOOD CASEWORK
06 6400	PLASTIC PANELING

DIVISION 07 - THERMAL AND MOISTURE PROTECTION

07 2100	THERMAL INSULATION
07 2119	FOAMED-IN-PLACE INSULATION
07 2715	NONBITUMINOUS SELF-ADHERING SHEET AIR BARRIERS
07 4213.23	METAL COMPOSITE MATERIAL WALL PANELS
07 4293	SOFFIT PANELS
07 5423	THERMOPLASTIC-POLYOLEFIN (TPO) ROOFING
07 7100	ROOF SPECIALTIES
07 8413	PENETRATION FIRESTOPPING
07 8443	JOINT FIRESTOPPING
07 9200	JOINT SEALANTS
07 9219	ACOUSTICAL JOINT SEALANTS

DIVISION 08 - OPENINGS

08 1113	HOLLOW METAL DOORS AND FRAMES
08 1416	FLUSH WOOD DOORS
08 3326	OVERHEAD COILING GRILLES
08 4126.23	INTERIOR ALL-GLASS ENTRANCES
08 4213	ALUMINUM-FRAMED ENTRANCES
08 4313	ALUMINUM-FRAMED STOREFRONTS
08 5653	SECURITY WINDOWS
08 7100	DOOR HARDWARE
08 7113	POWER DOOR OPERATORS
08 8000	GLAZING
08 8300	MIRRORS
08 8853	SECURITY GLAZING

DIVISION 09 - FINISHES

09 2116.23	GYPSUM BOARD SHAFT WALL ASSEMBLIES
09 2216	NON-STRUCTURAL METAL FRAMING
09 2900	GYPSUM BOARD
09 3013	CERAMIC TILING
09 5113	ACOUSTICAL PANEL CEILINGS
09 5123	ACOUSTICAL TILE CEILINGS
09 5426	SUSPENDED WOOD CEILINGS
09 6513	RESILIENT BASE AND ACCESSORIES
09 6516	RESILIENT SHEET FLOORING
09 6519	RESILIENT TILE AND PLANK FLOORING
09 6543	LINOLEUM FLOORING
09 6566	RESILIENT ATHLETIC FLOORING

09 6813	TILE CARPETING
09 7200	WALL COVERINGS
09 9113	EXTERIOR PAINTING
09 9123	INTERIOR PAINTING
09 9300	STAINING AND TRANSPARENT FINISHING
09 9653	ELASTOMERIC COATINGS

DIVISION 10 - SPECIALTIES

10 2239	FOLDING PANEL PARTITIONS
10 2600	WALL AND DOOR PROTECTION
10 2800	TOILET, BATH, AND LAUNDRY ACCESSORIES
10 2819	TUB AND SHOWER ENCLOSURES
10 4413	FIRE PROTECTION CABINETS
10 4416	FIRE EXTINGUISHERS
10 7313	AWNINGS
10 7516	GROUND-SET FLAGPOLES

DIVISION 11 - EQUIPMENT

11 1200	PARKING CONTROL EQUIPMENT
---------	---------------------------

DIVISION 12 - FURNISHINGS

12 2413	ROLLER WINDOW SHADES
12 3616	METAL COUNTERTOPS
12 3623.13	PLASTIC-LAMINATE-CLAD COUNTERTOPS
12 3661	SIMULATED STONE COUNTERTOPS

DIVISION 21 - FIRE SUPPRESSION

21 0500	COMMON WORK RESULTS FOR FIRE SUPPRESSION
21 0553	IDENTIFICATION FOR FIRE SUPPRESSION PIPING AND EQUIPMENT
21 1300	FIRE-SUPPRESSION SPRINKLER SYSTEMS

DIVISION 22 - PLUMBING

22 0516	EXPANSION FITTINGS AND LOOPS FOR PLUMBING PIPING
22 0517	SLEEVES AND SLEEVE SEALS FOR PLUMBING PIPING
22 0523	GENERAL-DUTY VALVES FOR PLUMBING PIPING
22 0529	HANGERS AND SUPPORTS FOR PLUMBING PIPING AND EQUIPMENT
22 0553	IDENTIFICATION FOR PLUMBING PIPING AND EQUIPMENT
22 0719	PLUMBING PIPING INSULATION
22 0719.11	UNDER-LAVATORY PIPE AND SUPPLY COVERS
22 1005	PLUMBING PIPING

22 1006 PLUMBING PIPING SPECIALTIES
22 1119 DOMESTIC WATER PIPING SPECIALTIES
22 4000 PLUMBING FIXTURES

DIVISION 23 - HEATING, VENTILATING, AND AIR CONDITIONING

23 0516 EXPANSION FITTING AND LOOPS FOR HVAC
PIPING
23 0517 SLEEVES AND SLEEVE SEALS FOR HVAC PIPING
23 0523 GENERAL-DUTY VALVES FOR HVAC PIPING
23 0529 HANGERS AND SUPPORTS FOR HVAC PIPING
AND EQUIPMENT
23 0553 IDENTIFICATION FOR HVAC PIPING AND
EQUIPMENT
23 0593 TESTING, ADJUSTING, AND BALANCING FOR
HVAC
23 0713 DUCT INSULATION
23 0719 HVAC PIPING INSULATION
23 0800 COMMISSIONING OF HVAC
23 0913 INSTRUMENTATION AND CONTROL DEVICES FOR
HVAC
23 1123 FACILITY NATURAL-GAS PIPING
23 2113 HYDRONIC PIPING
23 2114 HYDRONIC SPECIALTIES
23 3100 HVAC DUCTS AND CASINGS
23 3300 AIR DUCT ACCESSORIES
23 3600 AIR TERMINAL UNITS
23 3700 AIR OUTLETS AND INLETS
23 8200 CONVECTION HEATING AND COOLING UNITS

DIVISION 26 - ELECTRICAL

26 0000 ELECTRICAL GENERAL PROVISIONS
26 0500 SERVICE AND DISTRIBUTION
26 2400 LIGHTING
26 5000 FIRE DETECTION AND EMERGENCY

DIVISION 27 - COMMUNICATIONS

27 5119 SOUND MASKING SYSTEMS

DIVISION 28 - ELECTRONIC SAFETY AND SECURITY

28 4600 FIRE DETECTION AND EMERGENCY
COMMUNICATION ALARM SYSTEM

DIVISION 31 - EARTHWORK

31 1000	SITE CLEARING
31 2000	EARTH MOVING
31 2319	DEWATERING
31 6615	HELICAL FOUNDATION PILES

DIVISION 32 - EXTERIOR IMPROVEMENTS

32 0523	CEMENT AND CONCRETE FOR EXTERIOR IMPROVEMENTS
32 1216	ASPHALT PAVING
32 1723	PAVEMENT MARKINGS
32 3119	DECORATIVE METAL FENCES AND GATES
32 3119.53	DECORATIVE METAL SECURITY FENCES AND GATES
32 3300	SITE FURNISHINGS
32 9200	TURF AND GRASSES
33 4000	STORM SEWER UTILITIES

END OF TABLE OF CONTENTS

SECTION 000101 - PROJECT TITLE PAGE

PART 1 - GENERAL

1. PROJECT MANUAL

A. VOLUME 1.



1. Kalamazoo Crosstown Parkway Facility.
2. City of Kalamazoo.
3. Kalamazoo, Michigan.
4. Architect Project No. 23046.
5. Intersect Studio.
6. 155 West Michigan Ave, Suite 1508.
7. Kalamazoo, MI.
8. Phone: (269) 775-1114.
9. Website: intersect-studio.com.
10. Issued: August 21, 2025.
11. Copyright 2025 Intersect Studio.

PART 2 - PRODUCTS (Not Used)

PART 3 - EXECUTION (Not Used)

END OF SECTION 000101

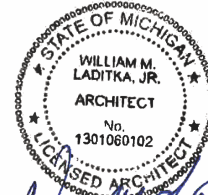
DOCUMENT 000107 - SEALS PAGE

1. GENERAL

1. DESIGN PROFESSIONALS OF RECORD

A. Architect:

1. Intersect Studio.
2. 1301060102.
3. Responsible for Divisions 01-49 Sections except where indicated as prepared by other design professionals of record.



William M. Laditka, Jr.

B. Civil Engineer:

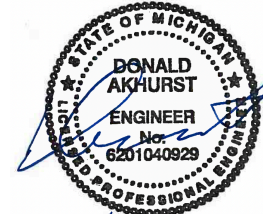
1. AR Engineering.
2. 6201315026.
3. Responsible for 311000, 312000, 312319, 320523, 321216, 321723, 329200, 334000.



Andrew Woloszyk

C. Structural Engineer:

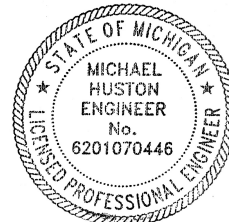
1. JDH Structural Engineering.
2. 6201040929.
3. Responsible for 031000, 032000, 033000, 033300, 036000, 051200, 053100, 054000, 316615.



Structural only

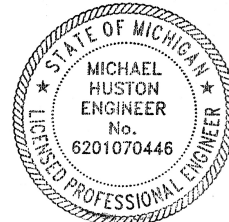
D. Fire-Protection Engineer:

1. Bialosky.
2. Michael Huston 6201070446..
3. Responsible for 210500 - 211300.



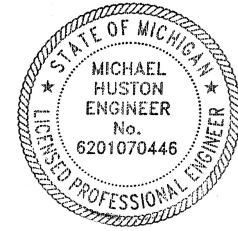
E. Mechanical Engineer, Plumbing:

1. Bialosky.
2. Michael Huston 6201070446.
3. Responsible for 220516 - 224000.



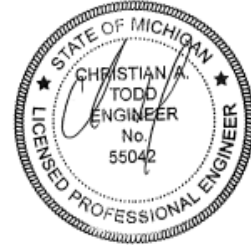
F. Mechanical Engineer, HVAC:

1. Bialosky.
2. Michael Huston 6201070446.
3. Responsible for 230516 - 238200.



G. Electrical Engineer:

1. McHenry & Associates Incorporated.
2. 55042.
3. Responsible for 26000, 260500, 262400, 265000, 284600.



2. PRODUCTS (Not Used)

3. EXECUTION (Not Used)

END OF DOCUMENT 000107

SECTION 012300 - ALTERNATES

1. GENERAL

1. SUMMARY

- A. Section includes administrative and procedural requirements for alternates.

2. DEFINITIONS

- A. Alternate: An amount proposed by bidders and stated on the Bid Form for certain work defined in the bidding requirements that may be added to or deducted from the base bid amount if the Owner decides to accept a corresponding change either in the amount of construction to be completed or in the products, materials, equipment, systems, or installation methods described in the Contract Documents.
 - 1. Alternates described in this Section are part of the Work only if enumerated in the Agreement.
 - 2. The cost or credit for each alternate is the net addition to or deduction from the Contract Sum to incorporate alternates into the Work. No other adjustments are made to the Contract Sum.

3. PROCEDURES

- A. Coordination: Revise or adjust affected adjacent work as necessary to completely integrate work of the alternate into Project.
 - 1. Include, as part of each alternate, miscellaneous devices, accessory objects, and similar items incidental to or required for a complete installation, whether or not indicated as part of alternate.
- B. Execute accepted alternates under the same conditions as other Work of the Contract.
- C. Schedule: A Part 3 "Schedule of Alternates" Article is included at the end of this Section. Specification Sections referenced in schedule contain requirements for materials necessary to achieve the work described under each alternate.

4. SCHEDULE OF ALTERNATES

- 1. Alternate No. 1: Toilet Rooms #122 & 124, #173 & #174, #251 & #253, #368 & #369.
 - a. Base Bid: Demo and replacement of ceramic flooring & wall base, countertops & lavatory sinks as indicated on Demolition Plans A001, A002, A003. Interior sheets I101, I102 & I103, and Plumbing Sheets P100, P101 & P102.
 - b. Alternate: Existing flooring, countertops & lavatory sinks to remain.

2. Alternate No. 2: KDPS Corridor Carpet
 - a. Base Bid: Demo and replacement of existing carpet in Corridor 221, Corridor 266 & Vestibule #267 and associated wall base as indicated on Drawings A002 & I102.
 - b. Alternate: Existing flooring & wall base to remain.
3. Alternate No. 3: Town Square #127 Ceiling Tile
 - a. Base Bid: Ceiling Tile AC-1 & AC-2 as indicated on Drawing A107.
 - b. Alternate: Substitute ACT-7.
4. Alternate No. 4: Connect Room #137 Ceiling Tile
 - a. Base Bid: Ceiling Tile ACT-8 as indicated on Drawing A107.
 - b. Alternate: Substitute ACT-7.
5. Alternate No. 5: Covered Bike Shelter
 - a. Base Bid: Provide covered bike shelter & screening on west end of site as shown on Drawing AS01, and structural drawings S101 & S104.
 - b. Alternate: Provide concrete pad and bike racks only, no covered shelter.
6. Alternate No. 6: Natural Gas Grille Hookup
 - a. Base Bid: Provide Natural gas hookup & emergency shutoff from building to exterior for gas grille at KDPS patio (@ Column line 12A) as indicated on Drawing P101.
 - b. Alternate: Extend natural gas to new gas range in Kitchen #197, no extension to exterior, no exterior hookup point or associated emergency shutoff.
7. Alternate No. 7: Installation of Operable Partition
 - a. Base Bid: Install 54 STC rated manual operable partition & track, as well as associated support posts/beams, wing walls, bulkheads, blocking & acoustically separated assemblies as indicated on Drawings A102, 8/A104 & 9/A104, A109, 1/A114 & Structural drawing S104, as well as Specifications Section 10 2239 FOLDING PANEL PARTITIONS.
 - b. Alternate: Install Structural support posts & beams for future operable partition per Structural drawing S104 and wing walls per Drawing A201 & 8/A104. Provide ACT-1 ceiling in place of new gyp. Bd. bulkheads.
8. Alternate No. 8: Exterior Window Type 'X1', 'X4', 'X13' and 'E'.
 - a. Base Bid: New or expanded exterior wall openings & new windows 'X1' in Comm Dev Room #114, 'X4' in Stair S-2, 'X13' in Town Square Room #127, and Type 'E' in Rooms #192, #258, and #260, plus associated demolition, construction &

structural support as indicated in Demolition Plans A001, A002 & A003, Floor Plans A100, A101 & A102, Wall Section Details 2/A301, 3/A302, 1/A302 & 4/A301, & Structural drawing S102, S103 & S104.

- b. Alternate: Existing window to remain in these locations, no new or expanded openings.

9. Alternate No. 9: Replace Existing Doors

- a. Base Bid: Existing wood doors to remain designated with finish 'DF-1' in Door Schedule on A401 shall be resurfaced with 3M Di-Noc Vinyl Film - see Finish schedule on I401.
- b. Alternate: Replace all existing doors designated to receive finish 'DF-1' with new solid core wood doors in finish 'DF-2.'

10. Alternate No. 10: Solid Core Wood Door Finish

- a. Base Bid: All new solid core wood doors to have wood veneer finish, as indicated on Drawings A401 and Specifications Section 08 1416 FLUSH WOOD DOORS. See Door finishes on Finish Schedule I401.
- b. Alternate: All new solid core wood doors shall have PLAM finish.

END OF SECTION 012300

SECTION 014000 - QUALITY REQUIREMENTS

PART 1 - GENERAL

1.1 SUMMARY

- A. Section includes administrative and procedural requirements for quality assurance and quality control.
- B. Testing and inspection services are required to verify compliance with requirements specified or indicated. These services do not relieve Contractor of responsibility for compliance with the Contract Document requirements.
 - 1. Specific quality-assurance and quality-control requirements for individual work results are specified in their respective Specification Sections. Requirements in individual Sections may also cover production of standard products.
 - 2. Specified tests, inspections, and related actions do not limit Contractor's other quality-assurance and quality-control procedures that facilitate compliance with the Contract Document requirements.
 - 3. Requirements for Contractor to provide quality-assurance and quality-control services required by Architect, Owner, Commissioning Authority, or authorities having jurisdiction are not limited by provisions of this Section.
- C. Related Requirements:
 - 1. Section 012100 "Allowances" for testing and inspection allowances.

1.2 DEFINITIONS

- A. Experienced: When used with an entity or individual, "experienced," unless otherwise further described, means having successfully completed a minimum of five previous projects similar in nature, size, and extent to this Project; being familiar with special requirements indicated; and having complied with requirements of authorities having jurisdiction.
- B. Field Quality-Control Tests and Inspections: Tests and inspections that are performed on-site for installation of the Work and for completed Work.
- C. Installer/Applicator/Erector: Contractor or another entity engaged by Contractor as an employee, subcontractor, or sub-subcontractor, to perform a particular construction operation, including installation, erection, application, assembly, and similar operations.
 - 1. Use of trade-specific terminology in referring to a Work result does not require that certain construction activities specified apply exclusively to specific trade(s).
- D. Mockups: Physical assemblies of portions of the Work constructed to establish the standard by which the Work will be judged. Mockups are not Samples.

1. Mockups are used for one or more of the following:
 - a. Verify selections made under Sample submittals.
 - b. Demonstrate aesthetic effects.
 - c. Demonstrate the qualities of products and workmanship.
 - d. Demonstrate successful installation of interfaces between components and systems.
 - e. Perform preconstruction testing to determine system performance.
 2. Product Mockups: Mockups that may include multiple products, materials, or systems specified in a single Section.
 3. In-Place Mockups: Mockups constructed on-site in their actual final location as part of permanent construction.
- E. Preconstruction Testing: Tests and inspections performed specifically for Project before products and materials are incorporated into the Work, to verify performance or compliance with specified criteria. Unless otherwise indicated, copies of reports of tests or inspections performed for other than the Project do not meet this definition.
- F. Product Tests: Tests and inspections that are performed by a nationally recognized testing laboratory (NRTL) in accordance with 29 CFR 1910.7, by a testing agency accredited in accordance with NIST's National Voluntary Laboratory Accreditation Program (NVLAP), or by a testing agency qualified to conduct product testing and acceptable to authorities having jurisdiction, to establish product performance and compliance with specified requirements.
- G. Source Quality-Control Tests and Inspections: Tests and inspections that are performed at the source (e.g., plant, mill, factory, or shop).
- H. Testing Agency: An entity engaged to perform specific tests, inspections, or both. The term "testing laboratory" has the same meaning as the term "testing agency."
- I. Quality-Assurance Services: Activities, actions, and procedures performed before and during execution of the Work, to guard against defects and deficiencies and substantiate that proposed construction will comply with requirements.
- J. Quality-Control Services: Tests, inspections, procedures, and related actions during and after execution of the Work, to evaluate that actual products incorporated into the Work and completed construction comply with requirements. Contractor's quality-control services do not include contract administration activities performed by Architect.
- 1.3 DELEGATED DESIGN SERVICES
- A. Performance and Design Criteria: Where professional design services or certifications by a design professional are specifically required of Contractor by the Contract Documents, provide products and systems complying with specific performance and design criteria indicated.
1. If criteria indicated are not sufficient to perform services or certification required, submit a written request for additional information to Architect.

- B. **Delegated Design Services Statement:** Submit a statement signed and sealed by the responsible design professional, for each product and system specifically assigned to Contractor to be designed or certified by a design professional, indicating that the products and systems are in compliance with performance and design criteria indicated. Include list of codes, loads, and other factors used in performing these services.

1.4 CONFLICTING REQUIREMENTS

- A. **Conflicting Standards and Other Requirements:** If compliance with two or more standards or requirements is specified and the standards or requirements establish different or conflicting requirements for minimum quantities or quality levels, inform the Architect regarding the conflict and obtain clarification prior to proceeding with the Work. Refer conflicting requirements that are different, but apparently equal, to Architect for clarification before proceeding.
- B. **Minimum Quantity or Quality Levels:** The quantity or quality level shown or specified is the minimum provided or performed. The actual installation may comply exactly with the minimum quantity or quality specified, or it may exceed the minimum within reasonable limits. To comply with these requirements, indicated numeric values are minimum or maximum, as appropriate, for the context of requirements. Refer uncertainties to Architect for a decision before proceeding.

1.5 ACTION SUBMITTALS

- A. **Mockup Shop Drawings:**
 - 1. Include plans, sections, elevations, and details, indicating materials and size of mockup construction.
 - 2. Indicate manufacturer and model number of individual components.
 - 3. Provide axonometric drawings for conditions difficult to illustrate in two dimensions.

1.6 INFORMATIONAL SUBMITTALS

- A. **Contractor's Quality-Control Plan:** For quality-assurance and quality-control activities and responsibilities.
- B. **Qualification Data:** For Contractor's quality-control personnel.
- C. **Contractor's Statement of Responsibility:** When required by authorities having jurisdiction, submit copy of written statement of responsibility submitted to authorities having jurisdiction before starting work on the following systems:
 - 1. Seismic-force-resisting system, designated seismic system, or component listed in the Statement of Special Inspections.
 - 2. Primary wind-force-resisting system or a wind-resisting component listed in the Statement of Special Inspections.

- D. Testing Agency Qualifications: For testing agencies specified in "Quality Assurance" Article to demonstrate their capabilities and experience. Include proof of qualifications in the form of a recent report on the inspection of the testing agency by a recognized authority.
- E. Schedule of Tests and Inspections: Prepare in tabular form and include the following:
 - 1. Specification Section number and title.
 - 2. Entity responsible for performing tests and inspections.
 - 3. Description of test and inspection.
 - 4. Identification of applicable standards.
 - 5. Identification of test and inspection methods.
 - 6. Number of tests and inspections required.
 - 7. Time schedule or time span for tests and inspections.
 - 8. Requirements for obtaining samples.
 - 9. Unique characteristics of each quality-control service.
- F. Reports: Prepare and submit certified written reports and documents as specified.
- G. Permits, Licenses, and Certificates: For Owner's record, submit copies of permits, licenses, certifications, inspection reports, releases, jurisdictional settlements, notices, receipts for fee payments, judgments, correspondence, records, and similar documents established for compliance with standards and regulations bearing on performance of the Work.

1.7 CONTRACTOR'S QUALITY-CONTROL PLAN

- A. Quality-Control Plan, General: Submit quality-control plan within 10 days of Notice of Award, and not less than five days prior to preconstruction conference. Submit in format acceptable to Architect. Identify personnel, procedures, controls, instructions, tests, records, and forms to be used to carry out Contractor's quality-assurance and quality-control responsibilities and to coordinate Owner's quality-assurance and quality-control activities. Coordinate with Contractor's Construction Schedule.
- B. Quality-Control Personnel Qualifications: Engage qualified personnel trained and experienced in managing and executing quality-assurance and quality-control procedures similar in nature and extent to those required for Project.
 - 1. Project quality-control manager may also serve as Project superintendent.
- C. Submittal Procedure: Describe procedures for ensuring compliance with requirements through review and management of submittal process. Indicate qualifications of personnel responsible for submittal review.
- D. Testing and Inspection: In quality-control plan, include a comprehensive schedule of Work requiring testing or inspection, including the following:
 - 1. Contractor-performed tests and inspections, including subcontractor-performed tests and inspections. Include required tests and inspections and Contractor-elected tests and inspections. Distinguish source quality-control tests and

- inspections from field quality-control tests and inspections.
 2. Special inspections required by authorities having jurisdiction and indicated on the Statement of Special Inspections.
 3. Owner-performed tests and inspections indicated in the Contract Documents, including tests and inspections indicated to be performed by Commissioning Authority.
- E. Continuous Inspection of Workmanship: Describe process for continuous inspection during construction to identify and correct deficiencies in workmanship in addition to testing and inspection specified. Indicate types of corrective actions to be required to bring the Work into compliance with standards of workmanship established by Contract requirements and approved mockups.
- F. Monitoring and Documentation: Maintain testing and inspection reports, including log of approved and rejected results. Include Work Architect has indicated as nonconforming or defective. Indicate corrective actions taken to bring nonconforming Work into compliance with requirements. Comply with requirements of authorities having jurisdiction.

1.8 REPORTS AND DOCUMENTS

- A. Test and Inspection Reports: Prepare and submit certified written reports specified in other Sections. Include the following:
1. Date of issue.
 2. Project title and number.
 3. Name, address, telephone number, and email address of testing agency.
 4. Dates and locations of samples and tests or inspections.
 5. Names of individuals making tests and inspections.
 6. Description of the Work and test and inspection method.
 7. Identification of product and Specification Section.
 8. Complete test or inspection data.
 9. Test and inspection results and an interpretation of test results.
 10. Record of temperature and weather conditions at time of sample-taking and testing and inspection.
 11. Comments or professional opinion on whether tested or inspected Work complies with the Contract Document requirements.
 12. Name and signature of laboratory inspector.
 13. Recommendations on retesting and reinspecting.
- B. Manufacturer's Technical Representative's Field Reports: Prepare written information documenting manufacturer's technical representative's tests and inspections specified in other Sections. Include the following:
1. Name, address, telephone number, and email address of technical representative making report.
 2. Statement on condition of substrates and their acceptability for installation of product.
 3. Statement that products at Project site comply with requirements.

4. Summary of installation procedures being followed, whether they comply with requirements and, if not, what corrective action was taken.
 5. Results of operational and other tests and a statement of whether observed performance complies with requirements.
 6. Statement of whether conditions, products, and installation will affect warranty.
 7. Other required items indicated in individual Specification Sections.
- C. Factory-Authorized Service Representative's Reports: Prepare written information documenting manufacturer's factory-authorized service representative's tests and inspections specified in other Sections. Include the following:
1. Name, address, telephone number, and email address of factory-authorized service representative making report.
 2. Statement that equipment complies with requirements.
 3. Results of operational and other tests and a statement of whether observed performance complies with requirements.
 4. Statement of whether conditions, products, and installation will affect warranty.
 5. Other required items indicated in individual Specification Sections.

1.9 QUALITY ASSURANCE

- A. Qualifications paragraphs in this article establish the minimum qualification levels required; individual Specification Sections specify additional requirements.
- B. Manufacturer Qualifications: A firm experienced in manufacturing products or systems similar to those indicated for this Project and with a record of successful in-service performance, as well as sufficient production capacity to produce required units. As applicable, procure products from manufacturers able to meet qualification requirements, warranty requirements, and technical or factory-authorized service representative requirements.
- C. Fabricator Qualifications: A firm experienced in producing products similar to those indicated for this Project and with a record of successful in-service performance, as well as sufficient production capacity to produce required units.
- D. Installer Qualifications: A firm or individual experienced in installing, erecting, applying, or assembling work similar in material, design, and extent to that indicated for this Project, whose work has resulted in construction with a record of successful in-service performance.
- E. Professional Engineer Qualifications: A professional engineer who is legally qualified to practice in jurisdiction where Project is located and who is experienced in providing engineering services of the kind indicated. Engineering services are defined as those performed for installations of the system, assembly, or product that is similar in material, design, and extent to those indicated for this Project.
- F. Specialists: Certain Specification Sections require that specific construction activities be performed by entities who are recognized experts in those operations. Specialists will satisfy qualification requirements indicated and engage in the activities indicated.

1. Requirements of authorities having jurisdiction supersede requirements for specialists.
- G. Testing and Inspecting Agency Qualifications: An NRTL, an NVLAP, or an independent agency with the experience and capability to conduct testing and inspection indicated, as documented in accordance with ASTM E329, and with additional qualifications specified in individual Sections; and, where required by authorities having jurisdiction, that is acceptable to authorities.
- H. Manufacturer's Technical Representative Qualifications: An authorized representative of manufacturer who is trained and approved by manufacturer to observe and inspect installation of manufacturer's products that are similar in material, design, and extent to those indicated for this Project.
- I. Factory-Authorized Service Representative Qualifications: An authorized representative of manufacturer who is trained and approved by manufacturer to inspect, demonstrate, repair, and perform service on installations of manufacturer's products that are similar in material, design, and extent to those indicated for this Project.
- J. Preconstruction Testing: Where testing agency is indicated to perform preconstruction testing for compliance with specified requirements for performance and test methods, comply with the following:
1. Contractor's Responsibilities:
 - a. Provide test specimens representative of proposed products and construction.
 - b. Submit specimens in a timely manner with sufficient time for testing and analyzing results to prevent delaying the Work.
 - c. Provide sizes and configurations of test assemblies, mockups, and laboratory mockups to adequately demonstrate capability of products to comply with performance requirements.
 - d. Build site-assembled test assemblies and mockups, using installers who will perform same tasks for Project.
 - e. When testing is complete, remove test specimens and test assemblies, and mockups; do not reuse products on Project.
 2. Testing Agency Responsibilities: Submit a certified written report of each test, inspection, and similar quality-assurance service to Architect and Commissioning Authority, through Construction Manager, with copy to Contractor. Interpret tests and inspections, and state in each report whether tested and inspected Work complies with or deviates from the Contract Documents.
- K. Mockups: Before installing portions of the Work requiring mockups, build mockups for each form of construction and finish required to comply with the following requirements, using materials indicated for the completed Work:
1. Build mockups of size indicated.
 2. Build mockups in location indicated or, if not indicated, as directed by Architect or Construction Manager.

3. Notify Architect and Construction Manager seven days in advance of dates and times when mockups will be constructed.
4. Employ supervisory personnel who will oversee mockup construction. Employ workers who will be employed to perform same tasks during the construction at Project.
5. Demonstrate the proposed range of aesthetic effects and workmanship.
6. Obtain Architect's and Construction Manager's approval of mockups before starting corresponding Work, fabrication, or construction.
 - a. Allow seven days for initial review and each re-review of each mockup.
7. Promptly correct unsatisfactory conditions noted by Architect's preliminary review, to the satisfaction of the Architect, before completion of final mockup.
8. Approval of mockups by the Architect does not constitute approval of deviations from the Contract Documents contained in mockups unless Architect specifically approves such deviations in writing.
9. Maintain mockups during construction in an undisturbed condition as a standard for judging the completed Work.
10. Demolish and remove mockups when directed unless otherwise indicated.

1.10 QUALITY CONTROL

- A. Owner Responsibilities: Where quality-control services are indicated as Owner's responsibility, Owner will engage a qualified testing agency to perform these services.
 1. Owner will furnish Contractor with names, addresses, and telephone numbers of testing agencies engaged and a description of types of testing and inspection they are engaged to perform.
 2. Payment for these services will be made from testing and inspection allowances specified in Section 012100 "Allowances," as authorized by Change Orders.
 3. Costs for retesting and reinspecting construction that replaces or is necessitated by Work that failed to comply with the Contract Documents will be charged to Contractor, and the Contract Sum will be adjusted by Change Order.
- B. Contractor Responsibilities: Tests and inspections not explicitly assigned to Owner are Contractor's responsibility. Perform additional quality-control activities, whether specified or not, to verify and document that the Work complies with requirements.
 1. Unless otherwise indicated, provide quality-control services specified and those required by authorities having jurisdiction. Perform quality-control services required of Contractor by authorities having jurisdiction, whether specified or not.
 2. Engage a qualified testing agency to perform quality-control services.
 - a. Contractor will not employ same entity engaged by Owner, unless agreed to in writing by Owner.
 3. Notify testing agencies at least 24 hours in advance of time when Work that requires testing or inspection will be performed.
 4. Where quality-control services are indicated as Contractor's responsibility, submit a certified written report, in duplicate, of each quality-control service.

5. Testing and inspection requested by Contractor and not required by the Contract Documents are Contractor's responsibility.
 6. Submit additional copies of each written report directly to authorities having jurisdiction, when they so direct.
- C. Retesting/Reinspecting: Regardless of whether original tests or inspections were Contractor's responsibility, provide quality-control services, including retesting and reinspecting, for construction that replaced Work that failed to comply with the Contract Documents.
- D. Testing Agency Responsibilities: Cooperate with Architect, Commissioning Authority and Contractor in performance of duties. Provide qualified personnel to perform required tests and inspections.
1. Notify Architect, Commissioning Authority, and Contractor promptly of irregularities or deficiencies observed in the Work during performance of its services.
 2. Determine the locations from which test samples will be taken and in which in-situ tests are conducted.
 3. Conduct and interpret tests and inspections, and state in each report whether tested and inspected Work complies with or deviates from requirements.
 4. Submit a certified written report, in duplicate, of each test, inspection, and similar quality-control service through Contractor.
 5. Do not release, revoke, alter, or increase the Contract Document requirements or approve or accept any portion of the Work.
 6. Do not perform duties of Contractor.
- E. Manufacturer's Field Services: Where indicated, engage a factory-authorized service representative to inspect field-assembled components and equipment installation, including service connections. Report results in writing as specified in Section 013300 "Submittal Procedures."
- F. Manufacturer's Technical Services: Where indicated, engage a manufacturer's technical representative to observe and inspect the Work. Manufacturer's technical representative's services include participation in preinstallation conferences, examination of substrates and conditions, verification of materials, observation of Installer activities, inspection of completed portions of the Work, and submittal of written reports.
- G. Contractor's Associated Requirements and Services: Cooperate with agencies and representatives performing required tests, inspections, and similar quality-control services, and provide reasonable auxiliary services as requested. Notify agency sufficiently in advance of operations to permit assignment of personnel. Provide the following:
1. Access to the Work.
 2. Incidental labor and facilities necessary to facilitate tests and inspections.
 3. Adequate quantities of representative samples of materials that require testing and inspection. Assist agency in obtaining samples.
 4. Facilities for storage and field curing of test samples.

5. Delivery of samples to testing agencies.
 6. Preliminary design mix proposed for use for material mixes that require control by testing agency.
 7. Security and protection for samples and for testing and inspection equipment at Project site.
- H. Coordination: Coordinate sequence of activities to accommodate required quality-assurance and quality-control services with a minimum of delay and to avoid necessity of removing and replacing construction to accommodate testing and inspection.
1. Schedule times for tests, inspections, obtaining samples, and similar activities.
- I. Schedule of Tests and Inspections: Prepare a schedule of tests, inspections, and similar quality-control services required by the Contract Documents as a component of Contractor's quality-control plan. Coordinate and submit concurrently with Contractor's Construction Schedule. Update and submit with each Application for Payment.
1. Schedule Contents: Include tests, inspections, and quality-control services, including Contractor- and Owner-retained services, commissioning activities, and other Project-required services paid for by other entities.
 2. Distribution: Distribute schedule to Owner, Architect, Commissioning Authority, testing agencies, and each party involved in performance of portions of the Work where tests and inspections are required.

1.11 SPECIAL TESTS AND INSPECTIONS

- A. Special Tests and Inspections: Owner will engage a qualified testing agency special inspector to conduct special tests and inspections required by authorities having jurisdiction as the responsibility of Owner, as indicated in the Statement of Special Inspections attached to this Section, and as follows:
1. Verifying that manufacturer maintains detailed fabrication and quality-control procedures, and reviewing the completeness and adequacy of those procedures to perform the Work.
 2. Notifying Architect, Commissioning Authority, , Construction Manager, and Contractor promptly of irregularities and deficiencies observed in the Work during performance of its services.
 3. Submitting a certified written report of each test, inspection, and similar quality-control service to Architect and Commissioning Authority , through Construction Manager, with copy to Contractor and to authorities having jurisdiction.
 4. Submitting a final report of special tests and inspections at Substantial Completion, which includes a list of unresolved deficiencies.
 5. Interpreting tests and inspections, and stating in each report whether tested and inspected Work complies with or deviates from the Contract Documents.
 6. Retesting and reinspecting corrected Work.

PART 2 - PRODUCTS (Not Used)
PART 3 - EXECUTION

3.1 TEST AND INSPECTION LOG

- A. Test and Inspection Log: Prepare a record of tests and inspections. Include the following:
 - 1. Date test or inspection was conducted.
 - 2. Description of the Work tested or inspected.
 - 3. Date test or inspection results were transmitted to Architect.
 - 4. Identification of testing agency or special inspector conducting test or inspection.
- B. Maintain log at Project site. Post changes and revisions as they occur. Provide access to test and inspection log for Architect's, Commissioning Authority's, and Construction Manager's and authorities' having jurisdiction reference during normal working hours.
 - 1. Submit log at Project closeout as part of Project Record Documents.

3.2 REPAIR AND PROTECTION

- A. General: On completion of testing, inspection, sample-taking, and similar services, repair damaged construction and restore substrates and finishes.
 - 1. Provide materials and comply with installation requirements specified in other Specification Sections or matching existing substrates and finishes. Restore patched areas and extend restoration into adjoining areas with durable seams that are as invisible as possible. Comply with the Contract Document requirements for cutting and patching in Section 017300 "Execution."
- B. Protect construction exposed by or for quality-control service activities.
- C. Repair and protection are Contractor's responsibility, regardless of the assignment of responsibility for quality-control services.

END OF SECTION 014000

SECTION 024119 - SELECTIVE DEMOLITION

PART 1 - GENERAL

1.1 SUMMARY

A. The Work of this Section Includes:

1. Demolition and removal of selected portions of exterior or interior of building or structure and site elements.
2. Removal and salvage of existing items for delivery to Owner and removal of existing items for reinstallation.

B. Related Requirements:

1. Section 011000 "Summary" for restrictions on use of the premises, Owner-occupancy requirements, and phasing requirements.
2. Section 017300 "Execution" for cutting and patching procedures.
3. Section 013516 "Alteration Project Procedures" for general protection and work procedures for alteration projects.
4. Section 311000 "Site Clearing" for site clearing and removal of above- and below-grade improvements not part of selective demolition.
5. Section 330500 "Common Work Results for Utilities" for removal of site utility systems piping, equipment, and components.

1.2 DEFINITIONS

- A. Remove: Detach items from existing construction and legally dispose of off-site unless indicated to be removed and salvaged or removed and reinstalled.
- B. Remove and Salvage: Detach items from existing construction, in a manner to prevent damage, and deliver to Owner as indicated.
- C. Remove and Reinstall: Detach items from existing construction, in a manner to prevent damage; prepare for reuse; and reinstall where indicated.
- D. Existing to Remain: Existing items of construction that are not to be removed.

1.3 MATERIALS OWNERSHIP

- A. Unless otherwise indicated, demolition waste becomes property of Contractor.
- B. Historic items, relics, antiques, and similar objects including, but not limited to, cornerstones and their contents, commemorative plaques and tablets, and other items of interest or value to Owner that may be uncovered during demolition remain the property of Owner.

1. Carefully salvage in a manner to prevent damage and promptly return to Owner.

1.4 COORDINATION

- A. Arrange selective demolition schedule so as not to interfere with Owner's operations.

1.5 PREINSTALLATION MEETINGS

- A. Predemolition Conference: Conduct conference at Project site.
 1. Inspect and discuss condition of construction to be selectively demolished.
 2. Review structural load limitations of existing structure.
 3. Review and finalize selective demolition schedule and verify availability of demolition personnel, equipment, and facilities needed to make progress and avoid delays.
 4. Review requirements of work performed by other trades that rely on substrates exposed by selective demolition operations.
 5. Review areas where existing construction is to remain and requires protection.
 6. Review and finalize protection requirements.
 7. Review procedures for noise control and dust control.
 8. Review storage, protection, and accounting for items to be removed for salvage or reinstallation.

1.6 INFORMATIONAL SUBMITTALS

- A. Qualification Statements: For refrigerant recovery technician.
- B. Engineering Survey: Submit engineering survey of condition of building.
- C. Survey of Existing Conditions: Submit survey.
- D. Proposed Protection Measures: Submit report, including Drawings, that indicates the measures proposed for protecting individuals and property. Indicate proposed locations and construction of barriers.
- E. Schedule of Selective Demolition Activities: Indicate the following:
 1. Detailed sequence of selective demolition and removal work, with starting and ending dates for each activity. Ensure Owner's on-site operations are uninterrupted.
 2. Temporary interruption of utility services. Indicate how long utility services will be interrupted.
 3. Coordination for shutoff, capping, and continuation of utility services.
 4. Use of elevator and stairs.
 5. Coordination of Owner's continuing occupancy of portions of existing building and of Owner's partial occupancy of completed Work.
- F. Warranties: Documentation indicating that existing warranties are still in effect after

completion of selective demolition.

1.7 CLOSEOUT SUBMITTALS

- A. Inventory: Submit a list of items that have been removed and salvaged.

1.8 QUALITY ASSURANCE

1.9 FIELD CONDITIONS

- A. Owner will not occupy portions of building immediately adjacent to selective demolition area. Conduct selective demolition so Owner's operations will not be disrupted.
- B. Conditions existing at time of inspection for bidding purpose will be maintained by Owner as far as practical.

- 1. Before selective demolition, Owner will remove the following items:

- a. Owner to remove furniture to keep, but not to be used in new space.

- C. Notify Architect of discrepancies between existing conditions and Drawings before proceeding with selective demolition.

- D. Hazardous Materials:

- 1. It is not expected that hazardous materials will be encountered in the Work.

- a. Hazardous materials will be removed by Owner before start of the Work.
 - b. If materials suspected of containing hazardous materials are encountered, do not disturb; immediately notify Architect and Owner. Hazardous materials will be removed by Owner under a separate contract.

- E. On-site sale of removed items or materials is not permitted.

1.10 WARRANTY

- A. Existing Warranties: Remove, replace, patch, and repair materials and surfaces cut or damaged during selective demolition, by methods and with materials and using approved contractors so as not to void existing warranties. Notify warrantor before proceeding. Existing warranties include the following:

- 1. Review with Owner.

- B. Notify warrantor on completion of selective demolition, and obtain documentation verifying that existing system has been inspected and warranty remains in effect. Submit documentation at Project closeout.

PART 2 - PRODUCTS

2.1 PERFORMANCE REQUIREMENTS

- A. Regulatory Requirements: Comply with governing EPA notification regulations before beginning selective demolition. Comply with hauling and disposal regulations of authorities having jurisdiction.
- B. Standards: Comply with ANSI/ASSP A10.6 and NFPA 241.
- C. Sustainable Design Requirements for Building Reuse:
 - 1. Maintain the existing building structure, envelope, and interior nonstructural elements of an abandoned or blighted building. Do not demolish such existing construction beyond indicated limits.
 - 2. Maintain the existing building structural systems where indicated to remain. Do not demolish such existing construction beyond indicated limits.
 - 3. Maintain the existing interior ceilings, interior partitions, and/or demountable walls where indicated to remain. Do not demolish such existing construction beyond indicated limits.

PART 3 - EXECUTION

3.1 EXAMINATION

- A. Verify that utilities have been disconnected and capped before starting selective demolition operations.
- B. Review Project Record Documents of existing construction or other existing condition and hazardous material information provided by Owner. Owner does not guarantee that existing conditions are same as those indicated in Project Record Documents.
- C. Notify structural engineer of any condition that is thought to be structurally deficient prior to removal for their review. .
 - 1. Perform surveys as the Work progresses to detect hazards resulting from selective demolition activities.
- D. Steel Tendons: Locate tensioned steel tendons and include recommendations for de-tensioning.
- E. Verify that hazardous materials have been remediated before proceeding with building demolition operations.
- F. Survey of Existing Conditions: Record existing conditions by use of preconstruction photographs or video, measured drawings and templates.
 - 1. Inventory and record the condition of items to be removed for salvage or

reinstallation. Photograph or video conditions that might be misconstrued as damage caused by removal.

2. Photograph or video existing conditions of adjoining construction including finish surfaces, that might be misconstrued as damage caused by selective demolition operations or removal of items for salvage or reinstallation.

3.2 PREPARATION

- A. Temporary Shoring: Design, provide, and maintain shoring, bracing, and structural supports as required to preserve stability and prevent movement, settlement, or collapse of construction and finishes to remain, and to prevent unexpected or uncontrolled movement or collapse of construction being demolished.
 1. Strengthen or add new supports when required during progress of selective demolition.
- B. Temporary Protection: Provide temporary barricades and other protection required to prevent injury to people and damage to adjacent buildings and facilities to remain.
 1. Provide protection to ensure safe passage of people around selective demolition area and to and from occupied portions of building.
 2. Provide temporary weather protection, during interval between selective demolition of existing construction on exterior surfaces and new construction, to prevent water leakage and damage to structure and interior areas.
 3. Protect walls, ceilings, floors, and other existing finish work that are to remain or that are exposed during selective demolition operations.
 4. Cover and protect furniture, furnishings, and equipment that have not been removed.
 5. Comply with requirements for temporary enclosures, dust control, heating, and cooling specified in Section 015000 "Temporary Facilities and Controls."
- C. Existing Items to Remain: Protect construction indicated to remain against damage and soiling during selective demolition. When permitted by Architect, items may be removed to a suitable, protected storage location and cleaned and reinstalled in their original locations after selective demolition operations are complete.
- D. Refrigerant: Before starting demolition, remove refrigerant from mechanical equipment in accordance with 40 CFR 82 and regulations of authorities having jurisdiction.

3.3 UTILITY SERVICES AND BUILDING SYSTEMS

- A. Existing Services/Systems to Remain: Maintain utilities and building systems and equipment to remain and protect against damage during selective demolition operations.
 1. Maintain fire-protection facilities in service during selective demolition operations.
- B. Existing Services/Systems to Be Removed, Relocated, or Abandoned: Locate, identify, disconnect, and seal or cap off utilities and building systems serving areas to be

selectively demolished.

1. Owner will arrange to shut off indicated utilities when requested by Contractor.
2. Arrange to shut off utilities with utility companies.
3. If disconnection of utilities and building systems will affect adjacent occupied parts of the building, provide temporary services/systems that bypass area of selective demolition and that maintain continuity of services/systems to those parts of the building.
4. Demolish and remove existing building systems, equipment, and components indicated on Drawings to be removed.
 - a. Piping to Be Removed: Remove portion of piping indicated to be removed and cap or plug remaining piping with same or compatible piping material.
 - b. Ducts to Be Removed: Remove portion of ducts indicated to be removed and plug remaining ducts with same or compatible ductwork material.
 - c. Equipment to Be Removed: Disconnect and cap services and remove equipment and components.
5. Abandon existing building systems, equipment, and components indicated on Drawings to be abandoned in place.
 - a. Piping to Be Abandoned in Place: Drain piping and cap or plug piping with same or compatible piping material and leave in place.
 - b. Ducts to Be Abandoned in Place: Cap or plug ducts with same or compatible ductwork material and leave in place.
6. Remove and reinstall/salvage existing building systems, equipment, and components indicated on drawings to be removed and reinstalled or removed and salvaged:
 - a. Equipment to Be Removed and Reinstalled: Disconnect and cap services and remove, clean, and store equipment and components; when appropriate, reinstall, reconnect, and make equipment operational.
 - b. Equipment to Be Removed and Salvaged: Disconnect and cap services and remove equipment and components and deliver to Owner.

3.4 SALVAGE/REINSTALL

A. Removed and Salvaged Items:

1. Clean salvaged items.
2. Pack or crate items after cleaning. Identify contents of containers with label indicating elements, date of removal, quantity, and location where removed.
3. Store items in a secure area until delivery to Owner.
4. Transport items to Owner's storage area designated by Owner.
5. Protect items from damage during transport and storage.

B. Removed and Reinstalled Items:

1. Clean and repair items to functional condition adequate for intended reuse.

2. Pack or crate items after cleaning and repairing. Identify contents of containers.
3. Protect items from damage during transport and storage.
4. Reinstall items in locations indicated. Comply with installation requirements for new materials and equipment. Provide connections, supports, and miscellaneous materials necessary to make item functional for use indicated.

3.5 SELECTIVE DEMOLITION, GENERAL

- A. General: Demolish and remove existing construction only to extent required by new construction and as indicated. Use methods required to complete the Work within limitations of governing regulations and as follows:
1. Proceed with selective demolition systematically, from higher to lower level. Complete selective demolition operations above each floor or tier before disturbing supporting members on the next lower level.
 2. Neatly cut openings and holes plumb, square, and true to dimensions required. Use cutting methods least likely to damage construction to remain or adjoining construction. Use hand tools or small power tools designed for sawing or grinding, not hammering and chopping. Temporarily cover openings to remain.
 3. Cut or drill from the exposed or finished side into concealed surfaces to avoid marring existing finished surfaces.
 4. Do not use cutting torches until work area is cleared of flammable materials. At concealed spaces, such as duct and pipe interiors, verify condition and contents of hidden space before starting flame-cutting operations. Maintain portable fire-suppression devices during flame-cutting operations.
 5. Maintain adequate ventilation when using cutting torches.
 6. Remove decayed, vermin-infested, or otherwise dangerous or unsuitable materials and promptly dispose of off-site.
 7. Remove structural framing members and lower to ground by method suitable to avoid free fall and to prevent ground impact or dust generation.
 8. Locate selective demolition equipment and remove debris and materials so as not to impose excessive loads on supporting walls, floors, or framing.
- B. Site Access and Temporary Controls: Conduct selective demolition and debris-removal operations to ensure minimum interference with roads, streets, walks, walkways, and other adjacent occupied and used facilities.
1. Do not close or obstruct streets, walks, walkways, or other adjacent occupied or used facilities without permission from Owner and authorities having jurisdiction. Provide alternate routes around closed or obstructed trafficways if required by authorities having jurisdiction.
 2. Use water mist and other suitable methods to limit spread of dust and dirt. Comply with governing environmental-protection regulations. Do not use water when it may damage adjacent construction or create hazardous or objectionable conditions, such as ice, flooding, and pollution.
- C. Work in Historic Areas: Selective demolition may be performed only in areas of Project that are not designated as historic. In historic spaces, areas, and rooms, or on historic surfaces, the terms "demolish" or "remove" to mean historic "removal" or "dismantling"

as specified in Section 024296 "Historic Removal and Dismantling."

3.6 SELECTIVE DEMOLITION PROCEDURES FOR SPECIFIC MATERIALS

A. Concrete:

1. Demolish in small sections. Using power-driven saw, cut concrete to a depth of at least **3/4 inch** at junctures with construction to remain. Dislodge concrete from reinforcement at perimeter of areas being demolished, cut reinforcement, and then remove remainder of concrete. Neatly trim openings to dimensions indicated.
2. Demolish in sections. Cut concrete full depth at junctures with construction to remain and at regular intervals using power-driven saw, and then remove concrete between saw cuts.

B. Masonry: Demolish in small sections. Cut masonry at junctures with construction to remain, using power-driven saw, and then remove masonry between saw cuts.

C. Concrete Slabs-on-Grade: Saw-cut perimeter of area to be demolished, and then break up and remove.

D. Resilient Floor Coverings: Remove floor coverings and adhesive in accordance with recommendations in RFCI's "Recommended Work Practices for the Removal of Resilient Floor Coverings."

3.7 DISPOSAL OF DEMOLISHED MATERIALS

A. Remove demolition waste materials from Project site and dispose of them in an EPA-approved construction and demolition waste landfill acceptable to authorities having jurisdiction.

1. Do not allow demolished materials to accumulate on-site.
2. Remove and transport debris in a manner that will prevent spillage on adjacent surfaces and areas.
3. Remove debris from elevated portions of building by chute, hoist, or other device that will convey debris to grade level in a controlled descent.
4. Comply with requirements specified in Section 017419 "Construction Waste Management and Disposal."

B. Burning: Do not burn demolished materials.

3.8 CLEANING

A. Clean adjacent structures and improvements of dust, dirt, and debris caused by selective demolition operations. Return adjacent areas to condition existing before selective demolition operations began.

Intersect Studio, LLC
23046

Kalamazoo Crosstown
Parkway Facility
Kalamazoo, Michigan

END OF SECTION 024119

SECTION 031000 - CONCRETE FORMING AND ACCESSORIES

1. GENERAL

1. RELATED DOCUMENTS

- A. Drawings and general provisions of the Contract, including General and Supplementary Conditions and Division 01 Specification Sections, apply to this Section. If differing requirements are identified elsewhere (in these specifications or on drawings or separate instructions), the more stringent requirement shall be met.

2. SUMMARY

A. Section Includes:

- 1. Form-facing material for cast-in-place concrete.
- 2. Form liners.
- 3. Insulating concrete forms.
- 4. Shoring, bracing, and anchoring.

B. Related Requirements:

- 1. Section 321313 "Concrete Paving" for formwork related to concrete pavement and walks.
- 2. Section 321316 "Decorative Concrete Paving" for formwork related to decorative concrete pavement and walks.

3. DEFINITIONS

- A. Form-Facing Material: Temporary structure or mold for the support of concrete while the concrete is setting and gaining sufficient strength to be self-supporting.
- B. Formwork: The total system of support of freshly placed concrete, including the mold or sheathing that contacts the concrete, as well as supporting members, hardware, and necessary bracing.

4. PREINSTALLATION MEETINGS

A. Preinstallation Conference: Conduct conference at Project site.

1. Review the following:

- a. Special inspection and testing and inspecting agency procedures for field quality control.
- b. Construction, movement, contraction, and isolation joints
- c. Forms and form-removal limitations.
- d. Shoring and reshoring procedures.
- e. Anchor rod and anchorage device installation tolerances.

5. ACTION SUBMITTALS

A. Product Data: For each of the following:

1. Exposed surface form-facing material.
2. Concealed surface form-facing material.
3. Forms for cylindrical columns.
4. Pan-type forms.
5. Void forms.
6. Form liners.
7. Insulating concrete forms.
8. Form ties.
9. Waterstops.
10. Form-release agent.

B. Shop Drawings: Prepared by, and signed and sealed by, a qualified professional engineer responsible for their preparation, detailing fabrication, assembly, and support of forms.

1. For exposed vertical concrete walls, indicate dimensions and form tie locations.
2. Indicate dimension and locations of construction and movement joints required to construct the structure in accordance with ACI 301.
 - a. Location of construction joints is subject to approval of the Architect.
3. Indicate location of waterstops.
4. Indicate form liner layout and form line termination details.
5. Indicate proposed schedule and sequence of stripping of forms, shoring removal, and reshoring installation and removal.
6. Indicate layout of insulating concrete forms, dimensions, course heights, form types, and details.

C. Samples:

1. For waterstops.
2. For Form Liners: 12-inch by 12-inch sample, indicating texture.

6. INFORMATIONAL SUBMITTALS

A. Qualification Data: For testing and inspection agency.

B. Research Reports: For insulating concrete forms indicating compliance with International Code Council Acceptance Criteria AC308.

C. Field quality-control reports.

D. Certified letter stating that they have done a survey of existing conditions.

E. Minutes of preinstallation conference.

7. QUALITY ASSURANCE

- A. Testing and Inspection Agency Qualifications: An independent agency, acceptable to authorities having jurisdiction, qualified in accordance with ASTM C1077 and ASTM E329 for testing indicated.
- B. Mockups: Formed surfaces to demonstrate typical joints, surface finish, texture, tolerances, and standard of workmanship.
 - 1. Build panel approximately **100 sq. ft.** in the location indicated or, if not indicated, as directed by Architect.
 - 2. Subject to compliance with requirements, approved mockups may become part of the completed Work.

8. DELIVERY, STORAGE, AND HANDLING

- A. Form Liners: Store form liners under cover to protect from sunlight.
- B. Insulating Concrete Forms: Store forms off ground and under cover to protect from moisture, sunlight, dirt, oil, and other contaminants.

2.PRODUCTS

1. PERFORMANCE REQUIREMENTS

- A. Concrete Formwork: Design, engineer, erect, shore, brace, and maintain formwork, shores, and reshores in accordance with ACI 301, to support vertical, lateral, static, and dynamic loads, and construction loads that might be applied, until structure can support such loads, so that resulting concrete conforms to the required shapes, lines, and dimensions.
 - 1. Design wood panel forms in accordance with APA's "Concrete Forming Design/Construction Guide."
 - 2. Design formwork to limit deflection of form-facing material to 1/240 of center-to-center spacing of supports.
 - a. For architectural concrete specified in Section 033300 "Architectural Concrete," limit deflection of form-facing material, studs, and walers to 0.0025 times their respective clear spans (L/400).

2. FORM-FACING MATERIALS

- A. As-Cast Surface Form-Facing Material:
 - 1. Provide continuous, true, and smooth concrete surfaces.
 - 2. Furnish in largest practicable sizes to minimize number of joints.
 - 3. Acceptable Materials: As required to comply with Surface Finish designations specified in Section 033000 "Cast-In-Place Concrete, and as follows:
 - a. Plywood, metal, or other approved panel materials.

- b. Exterior-grade plywood panels, suitable for concrete forms, complying with DOC PS 1, and as follows:
 - 1) APA HDO (high-density overlay).
 - 2) APA MDO (medium-density overlay); mill-release agent treated and edge sealed.
 - 3) APA Structural 1 Plyform, B-B or better; mill oiled and edge sealed.
 - 4) APA Plyform Class I, B-B or better; mill oiled and edge sealed.
 - B. Concealed Surface Form-Facing Material: Lumber, plywood, metal, plastic, or another approved material.
 1. Provide lumber dressed on at least two edges and one side for tight fit.
 - C. Forms for Cylindrical Columns, Pedestals, and Supports: Metal, glass-fiber-reinforced plastic, paper, or fiber tubes that produce surfaces with gradual or abrupt irregularities without spiral or vertical seams not exceeding specified formwork surface class.
 1. Provide forms with sufficient wall thickness to resist plastic concrete loads without
 - D. Form Liners:
 1. Manufacturers: Subject to compliance with requirements, provide products by the following:
 - a. Spec Formliners, Inc.
 2. Size: 1/2" (13mm) deep sine wave, 1" (25mm) pattern repeat.
 3. Face Pattern: 1708 1/2" Sine Wave.
3. RELATED MATERIALS
- A. Chamfer Strips: Wood, metal, PVC, or rubber strips, 3/4 by 3/4 inch, minimum.
 - B. Rustication Strips: Wood, metal, PVC, or rubber strips, kerfed for ease of form removal.
 - C. Form-Release Agent: Commercially formulated form-release agent that does not bond with, stain, or adversely affect concrete surfaces and does not impair subsequent treatments of concrete surfaces.
 1. Formulate form-release agent with rust inhibitor for steel form-facing materials.
 2. Form release agent for form liners shall be acceptable to form liner manufacturer.
 - D. Form Ties: Factory-fabricated, removable or snap-off, glass-fiber-reinforced plastic or metal form ties designed to resist lateral pressure of fresh concrete on forms and to prevent spalling of concrete on removal.
 1. Furnish units that leave no corrodible metal closer than 1 inch to the plane of exposed concrete surface.
 2. Furnish ties that, when removed, leave holes no larger than 1 inch in diameter in concrete surface.

3. Furnish ties with integral water-barrier plates to walls indicated to receive dampproofing or waterproofing.

3.EXECUTION

1. INSTALLATION OF FORMWORK

- A. Comply with ACI 301.
- B. Construct formwork, so concrete members and structures are of size, shape, alignment, elevation, and position indicated, within tolerance limits of ACI 117 and to comply with the Surface Finish designations specified in Section 033000 "Cast-In-Place Concrete" for as-cast finishes and Section 033300 "Architectural Concrete".
- C. Limit concrete surface irregularities as follows:
 1. Surface Finish-1.0: ACI 117 Class D, 1 inch.
 2. Surface Finish-2.0: ACI 117 Class B, 1/4 inch.
 3. Surface Finish-3.0: ACI 117 Class A, 1/8 inch.
- D. Construct forms tight enough to prevent loss of concrete mortar.
 1. Minimize joints.
 2. Exposed Concrete: Symmetrically align joints in forms.
- E. Construct removable forms for easy removal without hammering or prying against concrete surfaces.
 1. Provide crush or wrecking plates where stripping may damage cast-concrete surfaces.
 2. Provide top forms for inclined surfaces steeper than 1.5 horizontal to 1 vertical.
 3. Install keyways, reglets, recesses, and other accessories, for easy removal.
- F. Do not use rust-stained, steel, form-facing material.
- G. Set edge forms, bulkheads, and intermediate screed strips for slabs to achieve required elevations and slopes in finished concrete surfaces.
 1. Provide and secure units to support screed strips
 2. Use strike-off templates or compacting-type screeds.
- H. Provide temporary openings for cleanouts and inspection ports where interior area of formwork is inaccessible.
 1. Close openings with panels tightly fitted to forms and securely braced to prevent loss of concrete mortar.
 2. Locate temporary openings in forms at inconspicuous locations.
- I. Chamfer exterior corners and edges of permanently exposed concrete.
- J. At construction joints, overlap forms onto previously placed concrete not less than 12 inches.

- K. Form openings, chases, offsets, sinkages, keyways, reglets, blocking, screeds, and bulkheads required in the Work.
 - 1. Determine sizes and locations from trades providing such items.
 - 2. Obtain written approval of Architect prior to forming openings not indicated on Drawings.

 - L. Construction and Movement Joints:
 - 1. Construct joints true to line with faces perpendicular to surface plane of concrete.
 - 2. Install so strength and appearance of concrete are not impaired, at locations indicated or as approved by Architect.
 - 3. Place joints perpendicular to main reinforcement.
 - 4. Locate joints for beams, slabs, joists, and girders in the middle third of spans.
 - a. Offset joints in girders a minimum distance of twice the beam width from a beam-girder intersection.
 - 5. Locate horizontal joints in walls and columns at underside of floors, slabs, beams, and girders and at the top of footings or floor slabs.
 - 6. Space vertical joints in walls as indicated on Drawings.
 - a. Locate joints beside piers integral with walls, near corners, and in concealed locations where possible.

 - M. Provide temporary ports or openings in formwork where required to facilitate cleaning and inspection.
 - 1. Locate ports and openings in bottom of vertical forms, in inconspicuous location, to allow flushing water to drain.
 - 2. Close temporary ports and openings with tight-fitting panels, flush with inside face of form, and neatly fitted, so joints will not be apparent in exposed concrete surfaces.

 - N. Clean forms and adjacent surfaces to receive concrete. Remove chips, wood, sawdust, dirt, and other debris just before placing concrete.

 - O. Retighten forms and bracing before placing concrete, as required, to prevent mortar leaks and maintain proper alignment.

 - P. Coat contact surfaces of forms with form-release agent, according to manufacturer's written instructions, before placing reinforcement.
2. INSTALLATION OF EMBEDDED ITEMS
- A. Place and secure anchorage devices and other embedded items required for adjoining work that is attached to or supported by cast-in-place concrete.
 - 1. Use setting drawings, templates, diagrams, instructions, and directions furnished with items to be embedded.
 - 2. Install anchor rods, accurately located, to elevations required and complying with tolerances in Section 7.5 of AISC 303.

3. Install reglets to receive waterproofing and to receive through-wall flashings in outer face of concrete frame at exterior walls, where flashing is shown at lintels, shelf angles, and other conditions.
 4. Install dovetail anchor slots in concrete structures, as indicated on Drawings.
 5. Clean embedded items immediately prior to concrete placement.
- B. Self-Expanding Strip Waterstops: Install in construction joints and at other locations indicated on Drawings, according to manufacturer's written instructions, by adhesive bonding, mechanically fastening, and firmly pressing into place.
1. Install in longest lengths practicable.
 2. Locate waterstops in center of joint unless otherwise indicated on Drawings.
 3. Protect exposed waterstops during progress of the Work.
3. FORMS
- A. Formwork for sides of beams, walls, columns, and similar parts of the Work that does not support weight of concrete may be removed after cumulatively curing at not less than 50 deg F for 24 hours after placing concrete. Concrete has to be hard enough to not be damaged by form-removal operations, and curing and protection operations need to be maintained.
1. Leave formwork for beam soffits, joists, slabs, and other structural elements that support weight of concrete in place until concrete has achieved[**at least 70 percent of**] its 28-day design compressive strength.
 2. Remove forms only if shores have been arranged to permit removal of forms without loosening or disturbing shores.
- B. Clean and repair surfaces of forms to be reused in the Work.
1. Split, frayed, delaminated, or otherwise damaged form-facing material are unacceptable for exposed surfaces.
 2. Apply new form-release agent.
- C. When forms are reused, clean surfaces, remove fins and laitance, and tighten to close joints.
1. Align and secure joints to avoid offsets.
 2. Do not use patched forms for exposed concrete surfaces unless approved by Architect.
4. SHORING AND RESHORING INSTALLATION
- A. Comply with ACI 318 and ACI 301 for design, installation, and removal of shoring and reshoring.
1. Do not remove shoring or reshoring until measurement of slab tolerances is complete.
- B. In multistory construction, extend shoring or reshoring over a sufficient number of stories to distribute loads in such a manner that no floor or member will be excessively loaded or will induce tensile stress in concrete members without sufficient steel reinforcement.
- C. Plan sequence of removal of shores and reshore to avoid damage to concrete. Locate and provide adequate reshoring to support construction without excessive stress or deflection.

5. FIELD QUALITY CONTROL

- A. Special Inspections: Owner will engage a special inspector and qualified testing and inspecting agency to perform field tests and inspections and prepare test reports.
- B. Testing Agency: Engage a qualified testing and inspecting agency to perform tests and inspections and to submit reports.
- C. Inspections:
 - 1. Inspect formwork for shape, location, and dimensions of the concrete member being formed.
 - 2. Inspect insulating concrete forms for shape, location, and dimensions of the concrete member being formed.

END OF SECTION 031000

SECTION 032000 - CONCRETE REINFORCING

1. GENERAL

1. RELATED DOCUMENTS

- A. Drawings and general provisions of the Contract, including General and Supplementary Conditions and Division 01 Specification Sections, apply to this Section. If differing requirements are identified elsewhere (in these specifications or on drawings or separate instructions), the more stringent requirement shall be met.

2. SUMMARY

- A. Section Includes:
 - 1. Steel reinforcement bars.
 - 2. Welded-wire reinforcement.

3. PREINSTALLATION MEETINGS

- A. Preinstallation Conference: Conduct conference at Project site.

4. ACTION SUBMITTALS

- A. Product Data: For the following:
 - 1. Each type of steel reinforcement.
 - 2. Bar supports.
 - 3. Mechanical splice couplers.
- B. Shop Drawings: Comply with ACI SP-066:
 - 1. Include placing drawings that detail fabrication, bending, and placement.
 - 2. Include bar sizes, lengths, materials, grades, bar schedules, stirrup spacing, bent bar diagrams, bar arrangement, location of splices, lengths of lap splices, details of mechanical splice couplers, details of welding splices, tie spacing, hoop spacing, and supports for concrete reinforcement.
- C. Construction Joint Layout: Indicate proposed construction joints required to build the structure.
 - 1. Location of construction joints is subject to approval of Architect.

5. INFORMATIONAL SUBMITTALS

- A. Welding certificates – To be reviewed and verified by the special inspector
 - 1. Reinforcement to Be Welded: Welding procedure specification in accordance with AWS D1.4/D1.4M.

- B. Material Certificates: For each of the following, signed by manufacturers:
 - 1. Epoxy-Coated Reinforcement: CRSI's "Epoxy Coating Plant Certification."
- C. Material Test Reports: For the following, from a qualified testing agency:
 - 1. Steel Reinforcement:
 - a. For reinforcement to be welded, mill test analysis for chemical composition and carbon equivalent of the steel in accordance with ASTM A706/A706M.
 - 2. Mechanical splice couplers.
- D. Field quality-control reports.
- E. Minutes of preinstallation conference.

6. QUALITY ASSURANCE

- A. Welding Qualifications: Qualify procedures and personnel in accordance with AWS D1.4/D 1.4M.

2.PRODUCTS

1. STEEL REINFORCEMENT

- A. Reinforcing Bars: ASTM A615/A615M, Grade 60, deformed.
- B. Low-Alloy Steel Reinforcing Bars: ASTM A706/A706M, deformed.
- C. Headed-Steel Reinforcing Bars: ASTM A970/A970M.
- D. Plain-Steel Welded-Wire Reinforcement: ASTM A1064/A1064M, plain, fabricated from as-drawn steel wire into flat sheets.
- E. Deformed-Steel Welded-Wire Reinforcement: ASTM A1064/A1064M, flat sheet.

2. REINFORCEMENT ACCESSORIES

- A. Bar Supports: Bolsters, chairs, spacers, and other devices for spacing, supporting, and fastening reinforcing bars and welded-wire reinforcement in place.
 - 1. Manufacture bar supports from steel wire, plastic, or precast concrete in accordance with CRSI's "Manual of Standard Practice," of greater compressive strength than concrete and as follows:
 - a. For concrete surfaces exposed to view, where legs of wire bar supports contact forms, use CRSI Class 1 plastic-protected steel wire, all-plastic bar supports, or CRSI Class 2 stainless steel bar supports.

- B. Mechanical Splice Couplers: ACI 318 Type 1, same material of reinforcing bar being spliced; tension-compression type.
- C. Steel Tie Wire: ASTM A1064/A1064M, annealed steel, not less than 0.0508 inch in diameter.

3. FABRICATING REINFORCEMENT

- A. Fabricate steel reinforcement according to CRSI's "Manual of Standard Practice."

3.EXECUTION

1. PREPARATION

- A. Protection of In-Place Conditions:
 - 1. Do not cut or puncture vapor retarder.
 - 2. Repair damage and reseal vapor retarder before placing concrete.
- B. Clean reinforcement of loose rust and mill scale, earth, ice, and other foreign materials that reduce bond to concrete.

2. INSTALLATION OF STEEL REINFORCEMENT

- A. Comply with CRSI's "Manual of Standard Practice" for placing and supporting reinforcement.
- B. Accurately position, support, and secure reinforcement against displacement.
 - 1. Locate and support reinforcement with bar supports to maintain minimum concrete cover.
 - 2. Do not tack weld crossing reinforcing bars.
- C. Preserve clearance between bars of not less than 1 inch, not less than one bar diameter, or not less than 1-1/3 times size of large aggregate, whichever is greater.
- D. Provide concrete coverage in accordance with ACI 318.
- E. Set wire ties with ends directed into concrete, not toward exposed concrete surfaces.
- F. Splices: Lap splices as indicated on Drawings.
 - 1. Bars indicated to be continuous, and all vertical bars to be lapped not less than 36 bar diameters at splices, or 24 inches, whichever is greater.
 - 2. Stagger splices in accordance with ACI 318.
 - 3. Mechanical Splice Couplers: Install in accordance with manufacturer's instructions.
 - 4. Weld reinforcing bars in accordance with AWS D1.4/D 1.4M, where indicated on Drawings.
- G. Install welded-wire reinforcement in longest practicable lengths.
 - 1. Support welded-wire reinforcement in accordance with CRSI "Manual of Standard Practice."

- a. For reinforcement less than W4.0 or D4.0, continuous support spacing to not exceed 12 inches.
 2. Lap edges and ends of adjoining sheets at least one wire spacing plus 2 inches for plain wire and 8 inches for deformed wire.
 3. Offset laps of adjoining sheet widths to prevent continuous laps in either direction.
 4. Lace overlaps with wire.
3. JOINTS
- A. Construction Joints: Install so strength and appearance of concrete are not impaired, at locations indicated or as approved by Architect.
 1. Place joints perpendicular to main reinforcement.
 2. Continue reinforcement across construction joints unless otherwise indicated.
 3. Do not continue reinforcement through sides of strip placements of floors and slabs.
4. INSTALLATION TOLERANCES
- A. Comply with ACI 117.
5. FIELD QUALITY CONTROL
- A. Special Inspections: Owner will engage a special inspector and qualified testing and inspecting agency to perform field tests and inspections and prepare test reports.
 - B. Testing Agency: Engage a qualified testing and inspecting agency to perform tests and inspections and to submit reports.
 - C. Inspections:
 1. Steel-reinforcement placement.
 2. Steel-reinforcement mechanical splice couplers.
 3. Steel-reinforcement welding.

END OF SECTION 032000

SECTION 033000 - CAST-IN-PLACE CONCRETE

1. GENERAL

1. RELATED DOCUMENTS

- A. Drawings and general provisions of the Contract, including General and Supplementary Conditions and Division 01 Specification Sections, apply to this Section. If differing requirements are identified elsewhere (in these specifications or on drawings or separate instructions), the more stringent requirement shall be met.

2. SUMMARY

A. Section Includes:

- 1. Cast-in-place concrete, including concrete materials, mixture design, placement procedures, and finishes.

B. Related Requirements:

- 1. Section 031000 "Concrete Forming and Accessories" for form-facing materials, form liners, insulating concrete forms, and waterstops.
- 2. Section 032000 "Concrete Reinforcing" for steel reinforcing bars and welded-wire reinforcement.
- 3. Section 033300 "Architectural Concrete" for general building applications of specially finished formed concrete.
- 4. Section 033543 "Polished Concrete Finishing" for concrete floors scheduled to receive a polished concrete finish.
- 5. Section 035300 "Concrete Topping" for emery- and iron-aggregate concrete floor toppings.
- 6. Section 312000 "Earth Moving" for drainage fill under slabs-on-ground.
- 7. Section 321313 "Concrete Paving" for concrete pavement and walks.
- 8. Section 321316 "Decorative Concrete Paving" for decorative concrete pavement and walks.

3. DEFINITIONS

- A. Cementitious Materials: Portland cement alone or in combination with one or more of the following: blended hydraulic cement, fly ash, slag cement, other pozzolans, and silica fume; materials subject to compliance with requirements.
- B. Water/Cement Ratio (w/cm): The ratio by weight of water to cementitious materials.

4. PREINSTALLATION MEETINGS

- A. Preinstallation Conference: Conduct conference at Project site.

1. Require representatives of each entity directly concerned with cast-in-place concrete to attend, including the following:
 - a. Contractor's superintendent.
 - b. Independent testing agency responsible for concrete design mixtures.
 - c. Ready-mix concrete manufacturer.
 - d. Concrete Subcontractor.
 - e. Special concrete finish Subcontractor.

2. Review the following:
 - a. Special inspection and testing and inspecting agency procedures for field quality control.
 - b. Construction joints, control joints, isolation joints, and joint-filler strips.
 - c. Semirigid joint fillers.
 - d. Vapor-retarder installation.
 - e. Anchor rod and anchorage device installation tolerances.
 - f. Cold and hot weather concreting procedures.
 - g. Concrete finishes and finishing.
 - h. Curing procedures.
 - i. Forms and form-removal limitations.
 - j. Shoring and reshoring procedures.
 - k. Methods for achieving specified floor and slab flatness and levelness.
 - l. Floor and slab flatness and levelness measurements.
 - m. Concrete repair procedures.
 - n. Concrete protection.
 - o. Initial curing and field curing of field test cylinders (ASTM C31/C31M.)
 - p. Protection of field cured field test cylinders.

5. ACTION SUBMITTALS

A. Product Data: For each of the following.

1. Portland cement.
2. Fly ash.
3. Slag cement.
4. Blended hydraulic cement.
5. Silica fume.
6. Performance-based hydraulic cement
7. Aggregates.
8. Admixtures:
 - a. Include limitations of use, including restrictions on cementitious materials, supplementary cementitious materials, air entrainment, aggregates, temperature at time of concrete placement, relative humidity at time of concrete placement, curing conditions, and use of other admixtures.
9. Color pigments.
10. Fiber reinforcement.
11. Vapor retarders.
12. Floor and slab treatments.
13. Liquid floor treatments.

14. Curing materials.
 - a. Include documentation from color pigment manufacturer, indicating that proposed methods of curing are recommended by color pigment manufacturer.
15. Joint fillers.
16. Repair materials.

B. Design Mixtures: For each concrete mixture, include the following:

1. Mixture identification.
2. Minimum 28-day compressive strength.
3. Maximum w/cm.
4. Calculated equilibrium unit weight, for lightweight concrete.
5. Slump limit.
6. Air content.
7. Nominal maximum aggregate size.
8. Steel-fiber reinforcement content.
9. Synthetic micro-fiber content.
10. Indicate amounts of mixing water to be withheld for later addition at Project site if permitted.
11. Include manufacturer's certification that permeability-reducing admixture is compatible with mix design.
12. Include certification that dosage rate for permeability-reducing admixture matches dosage rate used in performance compliance test.
13. Submit alternate design mixtures when characteristics of materials, Project conditions, weather, test results, or other circumstances warrant adjustments.

C. Shop Drawings:

1. Construction Joint Layout: Indicate proposed construction joints required to construct the structure.
 - a. Location of construction joints is subject to approval of the Architect.

D. Concrete Schedule: For each location of each Class of concrete indicated in "Concrete Mixtures" Article, including the following:

1. Concrete Class designation.
2. Location within Project.
3. Exposure Class designation.
4. Formed Surface Finish designation and final finish.
5. Final finish for floors.
6. Curing process.
7. Floor treatment if any.

6. INFORMATIONAL SUBMITTALS

A. Qualification Data: For the following:

1. Installer: Include copies of applicable ACI certificates.
2. Ready-mixed concrete manufacturer.

3. Testing agency: Include copies of applicable ACI certificates.
 - B. Material Certificates: For each of the following, signed by manufacturers:
 1. Cementitious materials.
 2. Admixtures.
 3. Fiber reinforcement.
 4. Curing compounds.
 5. Floor and slab treatments.
 6. Bonding agents.
 7. Adhesives.
 8. Vapor retarders.
 9. Semirigid joint filler.
 10. Joint-filler strips.
 11. Repair materials.
 - C. Material Test Reports: For the following, from a qualified testing agency:
 1. Portland cement.
 2. Fly ash.
 3. Slag cement.
 4. Blended hydraulic cement.
 5. Silica fume.
 6. Performance-based hydraulic cement.
 7. Aggregates.
 8. Admixtures:
 - a. Permeability-Reducing Admixture: Include independent test reports, indicating compliance with specified requirements, including dosage rate used in test.
 - D. Floor surface flatness and levelness measurements report, indicating compliance with specified tolerances.
 - E. Certified letter stating that they have done a survey of existing conditions.
 - F. Research Reports:
 1. For concrete admixtures in accordance with ICC's Acceptance Criteria AC198.
 2. For sheet vapor retarder/termite barrier, showing compliance with ICC AC380.
 - G. Preconstruction Test Reports: For each mix design.
 - H. Field quality-control reports.
 - I. Minutes of preinstallation conference.
7. QUALITY ASSURANCE
- A. Installer Qualifications: A qualified installer who employs Project personnel qualified as an ACI-certified Flatwork Technician and Finisher and a supervisor who is a certified ACI Flatwork Concrete Finisher/Technician or an ACI Concrete Flatwork Technician with experience installing and finishing concrete, incorporating permeability-reducing admixtures.

- B. Ready-Mixed Concrete Manufacturer Qualifications: A firm experienced in manufacturing ready-mixed concrete products and that complies with ASTM C94/C94M requirements for production facilities and equipment.
- C. Laboratory Testing Agency Qualifications: A testing agency qualified in accordance with ASTM C1077 and ASTM E329 for testing indicated and employing an ACI-certified Concrete Quality Control Technical Manager.
- D. Field Quality Control Testing Agency Qualifications: An independent agency, acceptable to authorities having jurisdiction, qualified in accordance with ASTM C1077 and ASTM E329 for testing indicated.

8. PRECONSTRUCTION TESTING

- A. Preconstruction Testing Service: Engage a qualified testing agency to perform preconstruction testing on each concrete mixture.
 - 1. Include the following information in each test report:
 - a. Admixture dosage rates.
 - b. Slump.
 - c. Air content.
 - d. Seven-day compressive strength.
 - e. 28-day compressive strength.
 - f. Permeability.

9. DELIVERY, STORAGE, AND HANDLING

- A. Comply with ASTM C94/C94M and ACI 301.

10. FIELD CONDITIONS

- A. Cold-Weather Placement: Comply with ACI 301 and ACI 306.1 and as follows.
 - 1. Protect concrete work from physical damage or reduced strength that could be caused by frost, freezing actions, or low temperatures.
 - 2. When average high and low temperature is expected to fall below 40 deg F for three successive days, maintain delivered concrete mixture temperature within the temperature range required by ACI 301.
 - 3. Do not use frozen materials or materials containing ice or snow.
 - 4. Do not place concrete in contact with surfaces less than 35 deg F, other than reinforcing steel.
 - 5. Do not use calcium chloride, salt, or other materials containing antifreeze agents or chemical accelerators unless otherwise specified and approved in mixture designs.
- B. Hot-Weather Placement: Comply with ACI 301 and ACI 305.1, and as follows:
 - 1. Maintain concrete temperature at time of discharge to not exceed 95 deg F.
 - 2. Fog-spray forms, steel reinforcement, and subgrade just before placing concrete. Keep subgrade uniformly moist without standing water, soft spots, or dry areas.

11. WARRANTY

- A. Manufacturer's Warranty: Manufacturer agrees to furnish replacement sheet vapor retarder/ termite barrier material and accessories for sheet vapor retarder/ termite barrier and accessories that do not comply with requirements or that fail to resist penetration by termites within specified warranty period.
1. Warranty Period: 10 years from date of Substantial Completion.

2.PRODUCTS

1. CONCRETE, GENERAL

- A. ACI Publications: Comply with the following unless modified by requirements in the Contract Documents:

1. ACI 301.

2. CONCRETE MATERIALS

- A. Source Limitations:

1. Obtain each type or class of cementitious material of the same brand from the same manufacturer's plant.
2. Obtain aggregate from single source.
3. Obtain each type of admixture from single source from single manufacturer.

- B. Cementitious Materials:

1. Portland Cement: ASTM C150/C150M, or
2. Blended Cement: ASTM C595
3. Fly Ash: ASTM C618, Class C or F.
4. Slag Cement: ASTM C989/C989M, Grade 100 or 120.
5. Silica Fume: ASTM C1240 amorphous silica.

- C. Normal-Weight Aggregates: ASTM C33/C33M, Class 1N coarse aggregate or better, graded. Provide aggregates from a single source.

1. Alkali-Silica Reaction: Comply with one of the following:

- a. Expansion Result of Aggregate: Not more than 0.04 percent at one-year when tested in accordance with ASTM C1293.
- b. Expansion Results of Aggregate and Cementitious Materials in Combination: Not more than 0.10 percent at an age of 16 days when tested in accordance with ASTM C1567.
- c. Alkali Content in Concrete: Not more than 4 lb./cu. yd. for moderately reactive aggregate or 3 lb./cu. yd. for highly reactive aggregate, when tested in accordance with ASTM C1293 and categorized in accordance with ASTM C1778, based on alkali content being calculated in accordance with ACI 301.

2. Maximum Coarse-Aggregate Size: as indicated.
 3. Fine Aggregate: Free of materials with deleterious reactivity to alkali in cement.
- D. Lightweight Aggregate: ASTM C330/C330M, as indicated.
- E. Air-Entraining Admixture: ASTM C260/C260M.
- F. Chemical Admixtures: Certified by manufacturer to be compatible with other admixtures that do not contribute water-soluble chloride ions exceeding those permitted in hardened concrete. Do not use calcium chloride or admixtures containing calcium chloride in steel-reinforced concrete.
1. Water-Reducing Admixture: ASTM C494/C494M, Type A.
 2. Retarding Admixture: ASTM C494/C494M, Type B.
 3. Water-Reducing and -Retarding Admixture: ASTM C494/C494M, Type D.
 4. High-Range, Water-Reducing Admixture: ASTM C494/C494M, Type F.
 5. High-Range, Water-Reducing and -Retarding Admixture: ASTM C494/C494M, Type G.
 6. Plasticizing and Retarding Admixture: ASTM C1017/C1017M, Type II.
- G. Water and Water Used to Make Ice: ASTM C94/C94M, potable or complying with ASTM C1602/C1602M, including all limits listed in Table 2 and the requirements of paragraph 5.4
3. FIBER REINFORCEMENT
- A. Synthetic Fibrillated Micro-Fiber: Fibrillated polypropylene micro-fibers engineered and designed for use in concrete, complying with ASTM C1116/C1116M, Type III, 1/2 to 1-1/2 inches long.
1. **Manufacturers:** Subject to compliance with requirements, provide products by one of the following:
 - a. ABC Polymer Industries, LLC.
 - b. BASF Corporation.
 - c. Euclid Chemical Company (The); an RPM company.
 - d. GCP Applied Technologies Inc.
 - e. Propex Operating Company, LLC.
 - f. Sika Corporation.
- B. **Synthetic Macro-Fiber: Synthetic macro-fibers engineered and designed for use in concrete, complying with ASTM C1116/C1116M, Type III, 1 to 2-1/4 inches long.**
1. **Manufacturers:** Subject to compliance with requirements, provide products by one of the following:
 - a. ABC Polymer Industries, LLC.
 - b. Euclid Chemical Company (The); an RPM company.
 - c. GCP Applied Technologies Inc.
 - d. Propex Operating Company, LLC.
 - e. Sika Corporation.

4. VAPOR BARRIER/RETARDERS

- A. Sheet Vapor Barrier: ASTM E 1745, Class A, except with maximum perm rating of 0.01 or lower. Include manufacturer's recommended adhesive or pressure-sensitive tape.
1. Products: Subject to compliance with requirements, available products that may be incorporated into the Work include, but are not limited to, the following:
- a. Barrier-Bac; Inteplast Group, Ltd.; Seam Tape and VB-350.
 - b. Fortifiber Building Systems Group; Moistop Ultra 15.
 - c. Raven Industries, Inc; VaporBlock VB15.
 - d. Stego Industries, LLC; Stego Wrap Vapor Barrier (15-Mil).
 - e. W.R. Meadows, Inc; Perminator 15 mil.

5. CURING MATERIALS

- A. Evaporation Retarder: Waterborne, monomolecular film forming, manufactured for application to fresh concrete.
1. Products: Subject to compliance with requirements, available products that may be incorporated into the Work include, but are not limited to the following:
- a. BASF Corporation; MasterKure ER 50.
 - b. ChemMasters, Inc; Spray-Film.
 - c. Dayton Superior; AquaFilm J74RTU.
 - d. Euclid Chemical Company (The); an RPM company; Eucobar.
 - e. Kaufman Products, Inc; VaporAid.
 - f. Sika Corporation; SikaFilm.
- B. Absorptive Cover: AASHTO M 182, Class 2, burlap cloth made from jute or kenaf, weighing approximately 9 oz./sq. yd. when dry.
- C. Moisture-Retaining Cover: ASTM C171, polyethylene film burlap-polyethylene sheet.
1. Color:
- a. Ambient Temperature Below 50 deg F: Black.
 - b. Ambient Temperature between 50 deg F and 85 deg F: Any color.
 - c. Ambient Temperature Above 85 deg F: White.
- D. Curing Paper: Eight-foot-wide paper, consisting of two layers of fibred kraft paper laminated with double coating of asphalt.
- E. Water: Potable or complying with ASTM C1602/C1602M.
- F. Clear, Waterborne, Membrane-Forming, Dissipating Curing Compound: ASTM C309, Type 1, Class B.
- G. Clear, Waterborne, Membrane-Forming, Nondissipating Curing Compound: ASTM C309, Type 1, Class B, certified by curing compound manufacturer to not interfere with bonding of floor covering.

- H. Clear, Waterborne, Membrane-Forming, Curing Compound: ASTM C309, Type 1, Class B, 18 to 25 percent solids, nondissipating, certified by curing compound manufacturer to not interfere with bonding of floor covering.
- I. Clear, Solvent-Borne, Membrane-Forming, Curing and Sealing Compound: ASTM C1315, Type 1, Class A.
- J. Clear, Waterborne, Membrane-Forming, Curing and Sealing Compound: ASTM C1315, Type 1, Class A.

6. RELATED MATERIALS

- A. Expansion- and Isolation-Joint-Filler Strips: ASTM D1751, asphalt-saturated cellulosic fiber or ASTM D1752, cork or self-expanding cork.
- B. Bonding Agent: ASTM C1059/C1059M, Type II, nonredispersible, acrylic emulsion or styrene butadiene.
- C. Epoxy Bonding Adhesive: ASTM C881, two-component epoxy resin, capable of humid curing and bonding to damp surfaces, of class suitable for application temperature and of grade to suit requirements, and as follows:
 - 1. Types I and II for nonload bearing and Types IV and V for load bearing, for bonding hardened or freshly mixed concrete to hardened concrete.
- D. Floor Slab Protective Covering: Eight-foot-wide cellulose fabric.

7. REPAIR MATERIALS

- A. Repair Underlayment: Cement-based, polymer-modified, self-leveling product that can be applied in thicknesses from 1/8 inch and that can be feathered at edges to match adjacent floor elevations.
 - 1. Cement Binder: ASTM C150/C150M portland cement or hydraulic or blended hydraulic cement, as defined in ASTM C219.
 - 2. Primer: Product of underlayment manufacturer recommended for substrate, conditions, and application.
 - 3. Aggregate: Well-graded, washed gravel, 1/8 to 1/4 inch or coarse sand, as recommended by underlayment manufacturer.
 - 4. Compressive Strength: Not less than 4100 psi at 28 days when tested in accordance with ASTM C109/C109M.
- B. Repair Overlayment: Cement-based, polymer-modified, self-leveling product that can be applied in thicknesses from 1/4 inch and that can be filled in over a scarified surface to match adjacent floor elevations.
 - 1. Cement Binder: ASTM C150/C150M portland cement or hydraulic or blended hydraulic cement, as defined in ASTM C219.
 - 2. Primer: Product of topping manufacturer recommended for substrate, conditions, and application.

3. Aggregate: Well-graded, washed gravel, 1/8 to 1/4 inch or coarse sand as recommended by topping manufacturer.
4. Compressive Strength: Not less than 5000 psi at 28 days when tested in accordance with ASTM C109/C109M.

8. CONCRETE MIXTURES, GENERAL

- A. Prepare design mixtures for each type and strength of concrete, proportioned on the basis of laboratory trial mixture or field test data, or both, in accordance with ACI 301.
 1. Use a qualified testing agency for preparing and reporting proposed mixture designs, based on laboratory trial mixtures.
- B. Cementitious Materials: Limit percentage, by weight, of cementitious materials other than portland cement in concrete as indicated on drawings.
- C. Admixtures: Use admixtures in accordance with manufacturer's written instructions.
 1. Use water-reducing, high-range water-reducing or plasticizing admixture in concrete, as required, for placement and workability.
 2. Use water-reducing and -retarding admixture when required by high temperatures, low humidity, or other adverse placement conditions.
 3. Use water-reducing admixture in pumped concrete, concrete for heavy-use industrial slabs concrete for parking structure slabs, and concrete with a w/cm below 0.50.
 4. Use corrosion-inhibiting admixture in concrete mixtures where indicated.
 5. Use permeability-reducing admixture in concrete mixtures where indicated.
- D. Color Pigment: Add color pigment to concrete mixture in accordance with manufacturer's written instructions and to result in hardened concrete color consistent with approved mockup.

9. CONCRETE MIXTURES

- A. Provide concrete mixtures as indicated on drawings.

10. CONCRETE MIXING

- A. Ready-Mixed Concrete: Measure, batch, mix, and deliver concrete in accordance with ASTM C94/C94M[and ASTM C1116/C1116M], and furnish batch ticket information.
- B. Project-Site Mixing: Measure, batch, and mix concrete materials and concrete in accordance with ASTM C94/C94M. Mix concrete materials in appropriate drum-type batch machine mixer.
 1. For mixer capacity of 1 cu. yd. or smaller, continue mixing at least 1-1/2 minutes, but not more than five minutes after ingredients are in mixer, before any part of batch is released.
 2. For mixer capacity larger than 1 cu. yd., increase mixing time by 15 seconds for each additional 1 cu. yd..
 3. Provide batch ticket for each batch discharged and used in the Work, indicating Project identification name and number, date, mixture type, mixture time, quantity, and amount

- C. Prepare concrete mixes for each class of concrete given in the Schedule of Concrete Mixes. The mixes shall meet requirements given in ACI 318, ACI 301, and in this section.
- D. Provide the specified chemical and cementitious admixtures in each mix as shown in the Schedule of Concrete Mixes. Fly ash may be substituted for cement up to 20% (by weight) of the total cementitious materials quantity for any mix at the discretion of the concrete supplier. Approved chemical admixtures may be included in any concrete mix as required for the mix to meet the specified strength and durability requirements. The mix design documentation submitted for approval shall include the desired admixtures at the proposed dosage. See Paragraph 1.04 Submittals for additional requirements.
- E. Required sulfate resistance: Provide concrete mixes that meet or exceed sulfate resistance requirements given in the Schedule of Concrete Mixes as defined by ACI 318, Section 4.3.
- F. Minimum Freeze-Thaw Resistance: Provide concrete mixes that meet or exceed the minimum freeze-thaw requirements given in the Schedule of Concrete Mixes as defined by ACI 318, Section 4.2.1. Mild exposure indicates concrete incorporating air entrainment for reasons other than durability, such as to improve strength, workability, and cohesion or to reduce the amount of water in the mix.
- G. Allowed Chloride Ion Content: Provide concrete mixes that do not exceed the chloride ion content limits given in the Schedule of Concrete Mixes as defined in ACI 318, Section 4.4.3
- H. Permeability and Chloride Resistance: Provide concrete mixes that meet or exceed the permeability and chloride resistance requirements given in the Schedule of Concrete Mixes as defined by ACI 318, Section 4.2.23
 - 1. The level of permeability and chloride resistance is defined by the following:
 - a. I - concrete intended to have low permeability when exposed to water.
 - b. II – concrete exposed to freezing and thawing in a moist condition or to deicing chemicals.
 - c. III – for corrosion protection of reinforcement in concrete exposed to chlorides from deicing chemicals.
- I. NA – Not Applicable

3.EXECUTION

1. EXAMINATION

A. Verification of Conditions:

- 1. Before placing concrete, verify that installation of concrete forms, accessories, and reinforcement, and embedded items is complete and that required inspections have been performed.
- 2. Do not proceed until unsatisfactory conditions have been corrected.

2. PREPARATION

- A. Provide reasonable auxiliary services to accommodate field testing and inspections, acceptable to testing agency, including the following:

1. Access to the Work.
2. Incidental labor and facilities necessary to facilitate tests and inspections.
3. Secure facilities for storage, initial curing, and field curing of test samples, including continuous electrical power.
4. Security and protection for samples and for testing and inspection equipment at Project site.

3. INSTALLATION OF EMBEDDED ITEMS

- A. Place and secure anchorage devices and other embedded items required for adjoining Work that is attached to or supported by cast-in-place concrete.
1. Use setting drawings, templates, diagrams, instructions, and directions furnished with items to be embedded.
 2. Install anchor rods, accurately located, to elevations required and complying with tolerances in Section 7.5 of ANSI/AISC 303.
 3. Install reglets to receive waterproofing and to receive through-wall flashings in outer face of concrete frame at exterior walls, where flashing is shown at lintels, shelf angles, and other conditions.

4. INSTALLATION OF VAPOR RETARDER

- A. Sheet Vapor Barrier/Retarders: Place, protect, and repair sheet vapor retarder in accordance with ASTM E1643 and manufacturer's written instructions.
1. Install vapor retarder with longest dimension parallel with direction of concrete pour.
 2. Face laps away from exposed direction of concrete pour.
 3. Lap vapor retarder over footings and grade beams not less than 6 inches, sealing vapor retarder to concrete.
 4. Lap joints 6 inches and seal with manufacturer's recommended tape.
 5. Terminate vapor retarder at the top of floor slabs, grade beams, and pile caps, sealing entire perimeter to floor slabs, grade beams, foundation walls, or pile caps.
 6. Seal penetrations in accordance with vapor retarder manufacturer's instructions.
 7. Protect vapor retarder during placement of reinforcement and concrete.
 - a. Repair damaged areas by patching with vapor retarder material, overlapping damages area by 6 inches on all sides, and sealing to vapor retarder.

5. JOINTS

- A. Construct joints true to line, with faces perpendicular to surface plane of concrete.
- B. Construction Joints: Coordinate with floor slab pattern and concrete placement sequence.
1. Install so strength and appearance of concrete are not impaired, at locations indicated on Drawings or as approved by Architect.
 2. Place joints perpendicular to main reinforcement.
 - a. Continue reinforcement across construction joints unless otherwise indicated.

3. Form keyed joints as indicated. Embed keys at least 1-1/2 inches into concrete.
 4. Use a bonding agent at locations where fresh concrete is placed against hardened or partially hardened concrete surfaces where indicated.
 5. Use epoxy-bonding adhesive at locations where fresh concrete is placed against hardened or partially hardened concrete surfaces where indicated.
- C. Control Joints in Slabs-on-Ground: Form weakened-plane control joints, sectioning concrete into areas as indicated and as follows:
1. Grooved Joints: Form control joints after initial floating by grooving and finishing each edge of joint to a radius of 1/8 inch. Repeat grooving of control joints after applying surface finishes. Eliminate groover tool marks on concrete surfaces.
 2. Sawed Joints: Form control joints with power saws equipped with shatterproof abrasive or diamond-rimmed blades. Cut 1/8-inch-wide joints into concrete when cutting action does not tear, abrade, or otherwise damage surface and before concrete develops random cracks.
- D. Isolation Joints in Slabs-on-Ground: After removing formwork, install joint-filler strips at slab junctions with vertical surfaces, such as column pedestals, foundation walls, grade beams, and other locations, as indicated.
1. Extend joint-filler strips full width and depth of joint, terminating flush with finished concrete surface unless otherwise indicated on Drawings.
 2. Terminate full-width joint-filler strips not less than 1/2 inch or more than 1 inch below finished concrete surface, where joint sealants, specified in Section 079200 "Joint Sealants," are indicated.
 3. Install joint-filler strips in lengths as long as practicable. Where more than one length is required, lace or clip sections together.
- E. Doweled Joints:
1. Install dowel bars and support assemblies at joints where indicated on Drawings.
 2. Lubricate or asphalt coat one-half of dowel bar length to prevent concrete bonding to one side of joint.
- F. Dowel Plates: Install dowel plates at joints where indicated on Drawings.
6. CONCRETE PLACEMENT
- A. Before placing concrete, verify that installation of formwork, reinforcement, embedded items, and vapor retarder is complete and that required inspections are completed.
1. Immediately prior to concrete placement, inspect vapor retarder for damage and deficient installation, and repair defective areas.
 2. Provide continuous inspection of vapor retarder during concrete placement and make necessary repairs to damaged areas as Work progresses.
- B. Notify Architect and testing and inspection agencies 24 hours prior to commencement of concrete placement.

- C. Do not add water to concrete during delivery, at Project site, or during placement unless approved by Architect in writing, but not to exceed the amount indicated on the concrete delivery ticket.
 - 1. Do not add water to concrete after adding high-range water-reducing admixtures to mixture.

- D. Deposit concrete continuously in one layer or in horizontal layers of such thickness that no new concrete is placed on concrete that has hardened enough to cause seams or planes of weakness.
 - 1. If a section cannot be placed continuously, provide construction joints as indicated.
 - 2. Deposit concrete to avoid segregation.
 - 3. Deposit concrete in horizontal layers of depth not to exceed formwork design pressures and in a manner to avoid inclined construction joints.
 - 4. Consolidate placed concrete with mechanical vibrating equipment in accordance with ACI 301.
 - a. Do not use vibrators to transport concrete inside forms.
 - b. Insert and withdraw vibrators vertically at uniformly spaced locations to rapidly penetrate placed layer and at least 6 inches into preceding layer.
 - c. Do not insert vibrators into lower layers of concrete that have begun to lose plasticity.
 - d. At each insertion, limit duration of vibration to time necessary to consolidate concrete, and complete embedment of reinforcement and other embedded items without causing mixture constituents to segregate.

- E. Deposit and consolidate concrete for floors and slabs in a continuous operation, within limits of construction joints, until placement of a panel or section is complete.
 - 1. Do not place concrete floors and slabs in a checkerboard sequence.
 - 2. Consolidate concrete during placement operations, so concrete is thoroughly worked around reinforcement and other embedded items and into corners.
 - 3. Maintain reinforcement in position on chairs during concrete placement.
 - 4. Screed slab surfaces with a straightedge and strike off to correct elevations.
 - 5. Level concrete, cut high areas, and fill low areas.
 - 6. Slope surfaces uniformly to drains where required.
 - 7. Begin initial floating using bull floats or darbies to form a uniform and open-textured surface plane, before excess bleedwater appears on the surface.
 - 8. Do not further disturb slab surfaces before starting finishing operations.

7. FINISHING FORMED SURFACES

A. As-Cast Surface Finishes:

- 1. ACI 301 Surface Finish SF-1.0: As-cast concrete texture imparted by form-facing material.
 - a. Patch voids larger than 1-1/2 inches wide or 1/2 inch deep.
 - b. Remove projections larger than 1 inch.
 - c. Tie holes do not require patching.
 - d. Surface Tolerance: ACI 117 Class D.
 - e. Apply to concrete surfaces not exposed to public view.

2. ACI 301 Surface Finish SF-2.0: As-cast concrete texture imparted by form-facing material, arranged in an orderly and symmetrical manner with a minimum of seams.
 - a. Patch voids larger than 3/4 inch wide or 1/2 inch deep.
 - b. Remove projections larger than 1/4 inch.
 - c. Patch tie holes.
 - d. Surface Tolerance: ACI 117 Class B.
 - e. Locations: Apply to concrete surfaces exposed to public view, to receive a rubbed finish, or to be covered with a coating or covering material applied directly to concrete.

3. ACI 301 Surface Finish SF-3.0:
 - a. Patch voids larger than 3/4 inch wide or 1/2 inch deep.
 - b. Remove projections larger than 1/8 inch.
 - c. Patch tie holes.
 - d. Surface Tolerance: ACI 117 Class A.
 - e. Locations: Apply to concrete surfaces exposed to public view, to receive a rubbed finish, or to be covered with a coating or covering material applied directly to concrete.

B. Rubbed Finish: Apply the following to as cast surface finishes where indicated on Drawings:

1. Smooth-Rubbed Finish:
 - a. Perform no later than one day after form removal.
 - b. Moisten concrete surfaces and rub with carborundum brick or another abrasive until producing a uniform color and texture.
 - c. If sufficient cement paste cannot be drawn from the concrete by the rubbing process, use a grout made from the same cementitious materials used in the in-place concrete.

2. Grout-Cleaned Rubbed Finish:
 - a. Clean concrete surfaces after contiguous surfaces are completed and accessible.
 - b. Do not clean concrete surfaces as Work progresses.
 - c. Mix 1 part portland cement to 1-1/2 parts fine sand, complying with ASTM C144 or ASTM C404, by volume, with sufficient water to produce a mixture with the consistency of thick paint. Add white portland cement in amounts determined by trial patches, so color of dry grout matches adjacent surfaces.
 - d. Wet concrete surfaces.
 - e. Scrub grout into voids and remove excess grout. When grout whitens, rub surface with clean burlap, and keep surface damp by fog spray for at least 36 hours.

3. Cork-Floated Finish:
 - a. Mix 1 part portland cement to 1 part fine sand, complying with ASTM C144 or ASTM C404, by volume, with sufficient water to produce a mixture with the consistency of thick paint.
 - b. Mix 1 part portland cement and 1 part fine sand with sufficient water to produce a mixture of stiff grout. Add white portland cement in amounts determined by trial patches, so color of dry grout matches adjacent surfaces.
 - c. Wet concrete surfaces.

- d. Compress grout into voids by grinding surface.
 - e. In a swirling motion, finish surface with a cork float.
- C. Abrasive-Blast Finish: Apply the following to as-cast surface finishes where indicated on Drawings:
1. Perform abrasive blasting after compressive strength of concrete exceeds 2000 psi.
 2. Coordinate with formwork removal to ensure that surfaces to be abrasive blasted are treated at the same age.
 3. Surface Continuity:
 - a. Perform abrasive-blast finishing as continuous operation, maintaining continuity of finish on each surface or area of Work.
 - b. Maintain required patterns or variances in depths of blast to match field samples.
 4. Abrasive Blasting:
 - a. Abrasive-blast corners and edges of patterns carefully, using backup boards to maintain uniform corner and edge lines.
 - b. Determine type of nozzle pressure and blasting techniques required to match field sample.
 - c. Depth of Cut: Use an abrasive grit of proper type and gradation to expose aggregate and surrounding matrix surfaces to match field sample, as follows:
 - 1) Medium Texture: Generally, expose coarse aggregate with slight reveal and with a maximum reveal of 1/4 inch.
- D. Related Unformed Surfaces:
1. At tops of walls, horizontal offsets, and similar unformed surfaces adjacent to formed surfaces, strike off smooth and finish with a color and texture matching adjacent formed surfaces.
 2. Continue final surface treatment of formed surfaces uniformly across adjacent unformed surfaces unless otherwise indicated.
8. FINISHING FLOORS AND SLABS
- A. Comply with ACI 302.1R recommendations for screeding, restraightening, and finishing operations for concrete surfaces. Do not wet concrete surfaces.
- B. Scratch Finish:
1. While still plastic, texture concrete surface that has been screeded and bull-floated or darbied.
 2. Use stiff brushes, brooms, or rakes to produce a profile depth of 1/4 inch in one direction.
 3. Apply scratch finish to surfaces to receive concrete floor toppings to receive mortar setting beds for bonded cementitious floor finishes.
- C. Float Finish:

1. When bleedwater sheen has disappeared and concrete surface has stiffened sufficiently to permit operation of specific float apparatus, consolidate concrete surface with power-driven floats or by hand floating if area is small or inaccessible to power-driven floats.
2. Repeat float passes and restraightening until surface is left with a uniform, smooth, granular texture and complies with ACI 117 tolerances for conventional concrete.
3. Apply float finish to surfaces to receive trowel finish and to be covered with fluid-applied or sheet waterproofing, built-up or membrane roofing, or sand-bed terrazzo.

D. Trowel Finish:

1. After applying float finish, apply first troweling and consolidate concrete by hand or power-driven trowel.
2. Continue troweling passes and restraighten until surface is free of trowel marks and uniform in texture and appearance.
3. Grind smooth any surface defects that would telegraph through applied coatings or floor coverings.
4. Do not add water to concrete surface.
5. Do not apply hard-troweled finish to concrete, which has a total air content greater than 3 percent.
6. Apply a trowel finish to surfaces exposed to view or to be covered with resilient flooring, carpet, ceramic or quarry tile set over a cleavage membrane, paint, or another thin-film-finish coating system.
7. Finish surfaces to the following tolerances, in accordance with ASTM E1155, for a randomly trafficked floor surface:

a. Slabs on Ground:

- 1) Typical floor unless otherwise listed
 - a) SO FF 25/FL 20 with MLFF 17/MLFL 15.
- 2) Thin-set flooring and warehouse floor
 - a) SOI FF 35/FL 25 with MLFF 21/MLFL 13.

b. Suspended Slabs (for shored slabs prior to shoring removal):

- 1) Typical floor unless otherwise listed
 - a) SO FF 25/FL 20 with MLFF 17/MLFL 15.
- 2) Thin-set flooring and warehouse floor
 - a) SOI FF 35/FL 25 with MLFF 21/MLFL 13.

E. Trowel and Fine-Broom Finish: Apply a first trowel finish to surfaces indicated on Drawings or where ceramic or quarry tile is to be installed by either thickset or thinset method. While concrete is still plastic, slightly scarify surface with a fine broom perpendicular to main traffic route.

1. Coordinate required final finish with Architect before application.
2. Comply with flatness and levelness tolerances for trowel-finished floor surfaces.

F. Broom Finish: Apply a broom finish to exterior concrete platforms, steps, ramps, and locations indicated on Drawings.

1. Immediately after float finishing, slightly roughen trafficked surface by brooming with fiber-bristle broom perpendicular to main traffic route.
2. Coordinate required final finish with Architect before application.

9. INSTALLATION OF MISCELLANEOUS CONCRETE ITEMS

A. Filling In:

1. Fill in holes and openings left in concrete structures after Work of other trades is in place unless otherwise indicated.
2. Mix, place, and cure concrete, as specified, to blend with in-place construction.
3. Provide other miscellaneous concrete filling indicated or required to complete the Work.

B. Curbs: Provide monolithic finish to interior curbs by stripping forms while concrete is still green and by steel-troweling surfaces to a hard, dense finish with corners, intersections, and terminations slightly rounded.

C. Equipment Bases and Foundations:

1. Coordinate sizes and locations of concrete bases with actual equipment provided.
2. Construct concrete bases a minimum of 4 inches high unless otherwise indicated on Drawings, and extend base not less than 6 inches in each direction beyond the maximum dimensions of supported equipment unless otherwise indicated on Drawings, or unless required for seismic anchor support.
3. Minimum Compressive Strength: to match concrete surface it is placed on at 28 days.
4. Install dowel rods to connect concrete base to concrete floor. Unless otherwise indicated, install dowel rods on 18-inch centers around the full perimeter of concrete base.
5. For supported equipment, install epoxy-coated anchor bolts that extend through concrete base and anchor into structural concrete substrate.
6. Prior to pouring concrete, place and secure anchorage devices.
 - a. Use setting drawings, templates, diagrams, instructions, and directions furnished with items to be embedded.
 - b. Cast anchor-bolt insert into bases.
 - c. Install anchor bolts to elevations required for proper attachment to supported equipment.

D. Steel Pan Stairs: Provide concrete fill for steel pan stair treads, landings, and associated items.

1. Cast-in inserts and accessories, as shown on Drawings.
2. Screed, tamp, and trowel finish concrete surfaces.

10. CONCRETE CURING

A. Protect freshly placed concrete from premature drying and excessive cold or hot temperatures.

1. Comply with ACI 301 and ACI 306.1 for cold weather protection during curing.
2. Comply with ACI 301 and ACI 305.1 for hot-weather protection during curing.

B. Evaporation Retarder: Apply evaporation retarder to unformed concrete surfaces if hot, dry, or windy conditions cause moisture loss approaching 0.2 lb/sq. ft. x h before and during finishing operations. Apply in accordance with manufacturer's written instructions after placing, screeding, and bull floating or darbying concrete, but before float finishing.

C. Curing Formed Surfaces: Comply with ACI 308.1 as follows:

1. Cure formed concrete surfaces, including underside of beams, supported slabs, and other similar surfaces.
2. Cure concrete containing color pigments in accordance with color pigment manufacturer's instructions.
3. If forms remain during curing period, moist cure after loosening forms.
4. If removing forms before end of curing period, continue curing for remainder of curing period, as follows:
 - a. Continuous Fogging: Maintain standing water on concrete surface until final setting of concrete.
 - b. Continuous Sprinkling: Maintain concrete surface continuously wet.
 - c. Absorptive Cover: Pre-dampen absorptive material before application; apply additional water to absorptive material to maintain concrete surface continuously wet.
 - d. Water-Retention Sheeting Materials: Cover exposed concrete surfaces with sheeting material, taping, or lapping seams.
 - e. Membrane-Forming Curing Compound: Apply uniformly in continuous operation by power spray or roller in accordance with manufacturer's written instructions.
 - 1) Recoat areas subject to heavy rainfall within three hours after initial application.
 - 2) Maintain continuity of coating and repair damage during curing period.

D. Curing Unformed Surfaces: Comply with ACI 308.1 as follows:

1. Begin curing immediately after finishing concrete.
2. Interior Concrete Floors:
 - a. Floors to Receive Floor Coverings Specified in Other Sections: Contractor has option of the following:
 - 1) Absorptive Cover: As soon as concrete has sufficient set to permit application without marring concrete surface, install prewetted absorptive cover over entire area of floor.
 - a) Lap edges and ends of absorptive cover not less than 12-inches.
 - b) Maintain absorptive cover water saturated, and in place, for duration of curing period, but not less than seven days.
 - 2) Moisture-Retaining-Cover Curing: Cover concrete surfaces with moisture-retaining cover for curing concrete, placed in widest practicable width, with sides and ends lapped at least 12 inches, and sealed by waterproof tape or adhesive.
 - a) Immediately repair any holes or tears during curing period, using cover material and waterproof tape.
 - b) Cure for not less than seven days.
 - 3) Ponding or Continuous Sprinkling of Water: Maintain concrete surfaces continuously wet for not less than seven days, utilizing one, or a combination of, the following:
 - a) Water.

- b) Continuous water-fog spray.
- 4) Floors to Receive Curing Compound:
 - a) Apply uniformly in continuous operation by power spray or roller in accordance with manufacturer's written instructions.
 - b) Recoat areas subjected to heavy rainfall within three hours after initial application.
 - c) Maintain continuity of coating, and repair damage during curing period.
 - d) Removal: After curing period has elapsed, remove curing compound without damaging concrete surfaces by method recommended by curing compound manufacturer unless manufacturer certifies curing compound does not interfere with bonding of floor covering used on Project
- 5) Floors to Receive Curing and Sealing Compound:
 - a) Apply uniformly to floors and slabs indicated in a continuous operation by power spray or roller in accordance with manufacturer's written instructions.
 - b) Recoat areas subjected to heavy rainfall within three hours after initial application.
 - c) Repeat process 24 hours later, and apply a second coat. Maintain continuity of coating, and repair damage during curing period
- b. Floors to Receive Penetrating Liquid Floor Treatments: Contractor has option of the following:
 - 1) Absorptive Cover: As soon as concrete has sufficient set to permit application without marring concrete surface, install prewetted absorptive cover over entire area of floor.
 - a) Lap edges and ends of absorptive cover not less than 12 inches.
 - b) Maintain absorptive cover water saturated, and in place, for duration of curing period, but not less than seven days.
 - 2) Moisture-Retaining-Cover Curing: Cover concrete surfaces with moisture-retaining cover for curing concrete, placed in widest practicable width, with sides and ends lapped at least 12 inches, and sealed by waterproof tape or adhesive.
 - a) Immediately repair any holes or tears during curing period, using cover material and waterproof tape.
 - b) Cure for not less than seven days.
 - 3) Ponding or Continuous Sprinkling of Water: Maintain concrete surfaces continuously wet for not less than seven days, utilizing one, or a combination of, the following:
 - a) Water.
 - b) Continuous water-fog spray.
- c. Floors to Receive Polished Finish: Contractor has option of the following:

- 1) Absorptive Cover: As soon as concrete has sufficient set to permit application without marring concrete surface, install prewetted absorptive cover over entire area of floor.
 - a) Lap edges and ends of absorptive cover not less than 12 inches.
 - b) Maintain absorptive cover water saturated, and in place, for duration of curing period, but not less than seven days.
 - 2) Ponding or Continuous Sprinkling of Water: Maintain concrete surfaces continuously wet for not less than seven days, utilizing one, or a combination of, the following:
 - a) Water.
 - b) Continuous water-fog spray.
- d. Floors to Receive Chemical Stain:
- 1) As soon as concrete has sufficient set to permit application without marring concrete surface, install curing paper over entire area of floor.
 - 2) Install curing paper square to building lines, without wrinkles, and in a single length without end joints.
 - 3) Butt sides of curing paper tight; do not overlap sides of curing paper.
 - 4) Leave curing paper in place for duration of curing period, but not less than 28 days.
- e. Floors to Receive Urethane Flooring:
- 1) As soon as concrete has sufficient set to permit application without marring concrete surface, install prewetted absorptive cover over entire area of floor.
 - 2) Rewet absorptive cover, and cover immediately with polyethylene moisture-retaining cover with edges lapped 6 inches and sealed in place.
 - 3) Secure polyethylene moisture-retaining cover in place to prohibit air from circulating under polyethylene moisture-retaining cover.
 - 4) Leave absorptive cover and polyethylene moisture-retaining cover in place for duration of curing period, but not less than 28 days.
- f. Floors to Receive Curing Compound:
- 1) Apply uniformly in continuous operation by power spray or roller in accordance with manufacturer's written instructions.
 - 2) Recoat areas subjected to heavy rainfall within three hours after initial application.
 - 3) Maintain continuity of coating, and repair damage during curing period.
 - 4) Removal: After curing period has elapsed, remove curing compound without damaging concrete surfaces by method recommended by curing compound manufacturer unless manufacturer certifies curing compound does not interfere with bonding of floor covering used on Project.
- g. Floors to Receive Curing and Sealing Compound:
- 1) Apply uniformly to floors and slabs indicated in a continuous operation by power spray or roller in accordance with manufacturer's written instructions.

- 2) Recoat areas subjected to heavy rainfall within three hours after initial application.
- 3) Repeat process 24 hours later, and apply a second coat. Maintain continuity of coating, and repair damage during curing period.

11. TOLERANCES

- A. Conform to ACI 117 (UNO).

12. JOINT FILLING

- A. Prepare, clean, and install joint filler in accordance with manufacturer's written instructions.
 1. Defer joint filling until concrete has aged at least [**one**] [**six**] month(s).
 2. Do not fill joints until construction traffic has permanently ceased.
- B. Remove dirt, debris, saw cuttings, curing compounds, and sealers from joints; leave contact faces of joints clean and dry.
- C. Install semirigid joint filler full depth in saw-cut joints and at least 2 inches deep in formed joints.
- D. Overfill joint, and trim joint filler flush with top of joint after hardening.

13. CONCRETE SURFACE REPAIRS

- A. Defective Concrete:
 1. Repair and patch defective areas when approved by Architect.
 2. Remove and replace concrete that cannot be repaired and patched to Architect's approval.
- B. Patching Mortar: Mix dry-pack patching mortar, consisting of 1 part portland cement to 2-1/2 parts fine aggregate passing a No. 16 sieve, using only enough water for handling and placing.
- C. Repairing Formed Surfaces: Surface defects include color and texture irregularities, cracks, spalls, air bubbles, honeycombs, rock pockets, fins and other projections on the surface, and stains and other discolorations that cannot be removed by cleaning.
 1. Immediately after form removal, cut out honeycombs, rock pockets, and voids more than 1/2 inch in any dimension to solid concrete.
 - a. Limit cut depth to 3/4 inch.
 - b. Make edges of cuts perpendicular to concrete surface.
 - c. Clean, dampen with water, and brush-coat holes and voids with bonding agent.
 - d. Fill and compact with patching mortar before bonding agent has dried.
 - e. Fill form-tie voids with patching mortar or cone plugs secured in place with bonding agent.
 2. Repair defects on surfaces exposed to view by blending white portland cement and standard portland cement, so that, when dry, patching mortar matches surrounding color.

- a. Patch a test area at inconspicuous locations to verify mixture and color match before proceeding with patching.
 - b. Compact mortar in place and strike off slightly higher than surrounding surface.
3. Repair defects on concealed formed surfaces that will affect concrete's durability and structural performance as determined by Architect.

D. Repairing Unformed Surfaces:

1. Test unformed surfaces, such as floors and slabs, for finish, and verify surface tolerances specified for each surface.
 - a. Correct low and high areas.
 - b. Test surfaces sloped to drain for trueness of slope and smoothness; use a sloped template.
2. Repair finished surfaces containing surface defects, including spalls, popouts, honeycombs, rock pockets, crazing, and cracks in excess of 0.01 inch wide or that penetrate to reinforcement or completely through unreinforced sections regardless of width, and other objectionable conditions.
3. After concrete has cured at least 14 days, correct high areas by grinding.
4. Correct localized low areas during, or immediately after, completing surface-finishing operations by cutting out low areas and replacing with patching mortar.
 - a. Finish repaired areas to blend into adjacent concrete.
5. Correct other low areas scheduled to receive floor coverings with a repair underlayment.
 - a. Prepare, mix, and apply repair underlayment and primer in accordance with manufacturer's written instructions to produce a smooth, uniform, plane, and level surface.
 - b. Feather edges to match adjacent floor elevations.
6. Correct other low areas scheduled to remain exposed with repair topping.
 - a. Cut out low areas to ensure a minimum repair topping depth of 1/4 inch to match adjacent floor elevations.
 - b. Prepare, mix, and apply repair topping and primer in accordance with manufacturer's written instructions to produce a smooth, uniform, plane, and level surface.
7. Repair defective areas, except random cracks and single holes 1 inch or less in diameter, by cutting out and replacing with fresh concrete.
 - a. Remove defective areas with clean, square cuts, and expose steel reinforcement with at least a 3/4-inch clearance all around.
 - b. Dampen concrete surfaces in contact with patching concrete and apply bonding agent.
 - c. Mix patching concrete of same materials and mixture as original concrete, except without coarse aggregate.
 - d. Place, compact, and finish to blend with adjacent finished concrete.
 - e. Cure in same manner as adjacent concrete.

8. Repair random cracks and single holes 1 inch or less in diameter with patching mortar.
 - a. Groove top of cracks and cut out holes to sound concrete, and clean off dust, dirt, and loose particles.
 - b. Dampen cleaned concrete surfaces and apply bonding agent.
 - c. Place patching mortar before bonding agent has dried.
 - d. Compact patching mortar and finish to match adjacent concrete.
 - e. Keep patched area continuously moist for at least 72 hours.
- E. Perform structural repairs of concrete, subject to Architect's approval, using epoxy adhesive and patching mortar.
- F. Repair materials and installation not specified above may be used, subject to Architect's approval.

14. FIELD QUALITY CONTROL

- A. Special Inspections: Owner will engage a special inspector to perform field tests and inspections and prepare testing and inspection reports.
- B. Testing Agency: Owner will engage a qualified testing and inspecting agency to perform tests and inspections and to submit reports.
 1. Testing agency shall immediately report to Architect, Contractor, and concrete manufacturer any failure of Work to comply with Contract Documents.
 2. Testing agency shall report results of tests and inspections, in writing, to Owner, Architect, Contractor, and concrete manufacturer within 48 hours of inspections and tests.
 - a. Test reports shall include reporting requirements of ASTM C31/C31M, ASTM C39/C39M, and ACI 301, including the following as applicable to each test and inspection:
 - 1) Project name.
 - 2) Name of testing agency.
 - 3) Names and certification numbers of field and laboratory technicians performing inspections and testing.
 - 4) Name of concrete manufacturer.
 - 5) Date and time of inspection, sampling, and field testing.
 - 6) Date and time of concrete placement.
 - 7) Location in Work of concrete represented by samples.
 - 8) Date and time sample was obtained.
 - 9) Truck and batch ticket numbers.
 - 10) Design compressive strength at 28 days.
 - 11) Concrete mixture designation, proportions, and materials.
 - 12) Field test results.
 - 13) Information on storage and curing of samples before testing, including curing method and maximum and minimum temperatures during initial curing period.
 - 14) Type of fracture and compressive break strengths at seven days and 28 days.
- C. Batch Tickets: For each load delivered, submit three copies of batch delivery ticket to testing agency, indicating quantity, mix identification, admixtures, design strength, aggregate size,

design air content, design slump at time of batching, and amount of water that can be added at Project site.

D. Inspections:

1. Headed bolts and studs.
2. Verification of use of required design mixture.
3. Concrete placement, including conveying and depositing.
4. Curing procedures and maintenance of curing temperature.
5. Verification of concrete strength before removal of shores and forms from beams and slabs.
6. Batch Plant Inspections: On a random basis, as determined by Architect.

E. Concrete Tests: Testing of composite samples of fresh concrete obtained in accordance with ASTM C 172/C 172M shall be performed in accordance with the following requirements:

1. Testing Frequency: Obtain one composite sample for each day's pour of each concrete mixture exceeding 5 cu. yd., but less than 25 cu. yd., plus one set for each additional 50 cu. yd. or fraction thereof.
2. Slump: ASTM C143/C143M:
 - a. One test at point of placement for each composite sample, but not less than one test for each day's pour of each concrete mixture.
 - b. Perform additional tests when concrete consistency appears to change.
3. Slump Flow: ASTM C1611/C1611M:
 - a. One test at point of placement for each composite sample, but not less than one test for each day's pour of each concrete mixture.
 - b. Perform additional tests when concrete consistency appears to change.
4. Air Content: ASTM C231/C231M pressure method, for normal-weight concrete; ASTM C173/C173M volumetric method, for structural lightweight concrete.
 - a. One test for each composite sample, but not less than one test for each day's pour of each concrete mixture.
5. Concrete Temperature: ASTM C1064/C1064M:
 - a. One test hourly when air temperature is 40 deg F and below or 80 deg F and above, and one test for each composite sample.
6. Unit Weight: ASTM C567/C567M fresh unit weight of structural lightweight concrete.
 - a. One test for each composite sample, but not less than one test for each day's pour of each concrete mixture.
7. Compressive-Strength Tests: ASTM C39/C39M.
 - a. Test one set of two laboratory-cured specimens at seven days and one set of two specimens at 28 days.

- b. Test one set of two field-cured specimens at seven days and one set of two specimens at 28 days.
 - c. A compressive-strength test shall be the average compressive strength from a set of two specimens obtained from same composite sample and tested at age indicated.
 8. When strength of field-cured cylinders is less than 85 percent of companion laboratory-cured cylinders, Contractor shall evaluate operations and provide corrective procedures for protecting and curing in-place concrete.
 9. Strength of each concrete mixture will be satisfactory if every average of any three consecutive compressive-strength tests equals or exceeds specified compressive strength, and no compressive-strength test value falls below specified compressive strength by more than 500 psi if specified compressive strength is 5000 psi, or no compressive strength test value is less than 10 percent of specified compressive strength if specified compressive strength is greater than 5000 psi.
 10. Nondestructive Testing: Impact hammer, sonoscope, or other nondestructive device may be permitted by Architect but will not be used as sole basis for approval or rejection of concrete.
 11. Additional Tests:
 - a. Testing and inspecting agency shall make additional tests of concrete when test results indicate that slump, air entrainment, compressive strengths, or other requirements have not been met, as directed by Architect.
 - b. Testing and inspecting agency may conduct tests to determine adequacy of concrete by cored cylinders complying with ASTM C42/C42M or by other methods as directed by Architect.
 - 1) Acceptance criteria for concrete strength shall be in accordance with ACI 301 section 1.6.6.3.
 12. Additional testing and inspecting, at Contractor's expense, will be performed to determine compliance of replaced or additional work with specified requirements.
 13. Correct deficiencies in the Work that test reports and inspections indicate do not comply with the Contract Documents.
 - F. Measure floor and slab flatness and levelness in accordance with ASTM E1155 within 24 hours of completion of floor finishing and promptly report test results to Architect.
15. PROTECTION
- A. Protect concrete surfaces as follows:
 1. Protect from petroleum stains.
 2. Diaper hydraulic equipment used over concrete surfaces.
 3. Prohibit vehicles from interior concrete slabs.
 4. Prohibit use of pipe-cutting machinery over concrete surfaces.
 5. Prohibit placement of steel items on concrete surfaces.
 6. Prohibit use of acids or acidic detergents over concrete surfaces.
 7. Protect liquid floor treatment from damage and wear during the remainder of construction period. Use protective methods and materials, including temporary covering, recommended in writing by liquid floor treatments installer.
 8. Protect concrete surfaces scheduled to receive surface hardener or polished concrete finish using Floor Slab Protective Covering.

Intersect Studio, LLC
23046

Kalamazoo Crosstown
Parkway Facility
Kalamazoo, Michigan

END OF SECTION 033000

SECTION 033300 - ARCHITECTURAL CONCRETE

1. GENERAL

1. RELATED DOCUMENTS

- A. Drawings and general provisions of the Contract, including General and Supplementary Conditions and Division 1 Specification Sections, apply to this Section. If differing requirements are identified elsewhere (in these specifications or on drawings or separate instructions), the more stringent requirement shall be met.

2. SUMMARY

A. Section Includes:

- 1. Cast-in-place architectural concrete, including form facings, reinforcement and accessories, concrete materials, concrete mixture design, placement procedures, and finishes.
- 2. Requirements in Section 033000 "Cast-in-Place Concrete" apply to architectural concrete.

B. Related Requirements:

- 1. Section 033000 "Cast-in-Place Concrete" for concrete that apply to architectural concrete.

3. DEFINITIONS

- A. Aggregate Exposure: Projection of coarse aggregate from matrix or mortar after completion of exposure operations.
- B. Cast-in-Place Architectural Concrete: Concrete that is exposed to view, is designated as architectural concrete, and that requires special concrete materials, formwork, placement, or finishes to obtain specified architectural appearance.
- C. Cementitious Materials: Portland cement alone or in combination with one or more of the following: blended hydraulic cement, fly ash, slag cement, other pozzolans, and silica fume; materials subject to compliance with requirements.
- D. Design Reference Sample: Sample designated by Architect in the Contract Documents that reflects acceptable surface quality and appearance of cast-in-place architectural concrete.
- E. Water/Cement Ratio (w/cm): The ratio by weight of water to cementitious materials.

4. PREINSTALLATION MEETINGS

- A. Preinstallation Conference: Conduct conference at Project Site.

1. Require representatives of each entity directly concerned with cast-in-place architectural concrete to attend, including the following:
 - a. Contractor's superintendent.
 - b. Independent testing agency responsible for concrete design mixtures.
 - c. Ready-mix concrete manufacturer.
 - d. Cast-in-place architectural concrete Subcontractor.

2. Review the following:
 - a. Special inspection and testing and inspecting agency procedures for field quality control.
 - b. Construction joints, control joints, isolation joints, and joint-filler strips.
 - c. Reinforcement accessory installation.
 - d. Cold- and hot-weather concreting procedures.
 - e. Concrete finishes and finishing.
 - f. Curing procedures.
 - g. Forms and form-removal limitations.
 - h. Shoring and reshoring procedures.
 - i. Concrete repair procedures.
 - j. Protection of cast-in-place architectural concrete.
 - k. Initial curing and field curing of field test cylinders (ASTM C31/C31M).
 - l. Protection of field-cured field test cylinders.

5. ACTION SUBMITTALS

A. Product Data: For each of the following:

1. Form-facing panels.
2. Form liners.
3. Form joint tape.
4. Form joint sealant.
5. Wood sealer.
6. Form-release agent.
7. Surface retarder.
8. Form ties.
9. Bar supports.
10. Portland cement.
11. Fly ash.
12. Slag cement.
13. Blended hydraulic cement.
14. Natural or other pozzolans.
15. Silica fume.
16. Performance-based hydraulic cement.
17. Aggregates.
18. Admixtures:
 - a. Include limitations of use.
19. Color pigments.
20. Repair materials.

B. Design Mixtures: For each concrete mixture, include the following:

1. Mixture identification.
2. Minimum 28-day compressive strength.
3. Durability exposure class.
4. Maximum w/cm.
5. Calculated equilibrium unit weight, for lightweight concrete.
6. Slump limit.
7. Air content.
8. Nominal maximum aggregate size.
9. Steel-fiber reinforcement content.
10. Synthetic microfiber content.
11. Amounts of mixing water to be withheld for later addition at Project site if permitted.
12. Intended placement method.
13. Alternative design mixtures when characteristics of materials, Project conditions, weather, test results, or other circumstances warrant adjustments.

C. Shop Drawings:

1. Formwork: Prepared by, and signed and sealed by, a qualified professional engineer responsible for their preparation, detailing fabrication, assembly, and support of forms.
 - a. Show formwork construction, including form-liner layout, form-liner termination details, dimensioned locations of form-facing material joints, rustications, construction and contraction joints, form joint-sealant details, form-tie locations and patterns, inserts and embedments, cutouts, cleanout panels, and other items that visually affect cast-in-place architectural concrete.
 - 1) Indicate proposed schedule and sequence of stripping of forms, shoring removal, and reshoring installation and removal.
 - 2) Location of construction joints is subject to approval of Architect.

D. Samples: For each of the following materials:

1. Form-facing panels.
2. Form ties.
3. Form liners, 12-by-12-inch Sample, indicating texture.
4. Manufacturer's standard colors for color pigment.
5. Exposed aggregates.
6. Chamfers and rustications.

6. INFORMATIONAL SUBMITTALS

A. Qualification Data: For the following:

1. Installer: Include copies of applicable ACI certificates.
2. Ready-mixed concrete manufacturer.

B. Material Certificates: For each of the following:

1. Cementitious materials.
2. Admixtures.
3. Form materials and form-release agents.

4. Repair materials.

C. Material Test Reports: For the following, by a qualified testing agency:

1. Portland cement.
2. Fly ash.
3. Slag cement.
4. Blended hydraulic cement.
5. Silica fume.
6. Performance-based hydraulic cement.

D. Research Reports: For concrete admixtures in accordance with ICC AC198.

E. Preconstruction Test Reports: For each mix design.

F. Concrete Repair: Submit a written, detailed description of materials, methods, equipment, and sequence of operations to be used for repairing architectural concrete, including protection of surrounding materials and Project site.

1. If materials and methods other than those indicated are proposed for any repairs to architectural concrete, add a written description of such materials and methods, including evidence of successful use on comparable projects, and demonstrations to show their effectiveness for this Project and Installer's ability to use such materials and methods properly.

G. Minutes of preinstallation conference.

7. QUALITY ASSURANCE

A. Ready-Mixed Concrete Manufacturer Qualifications: A firm experienced in manufacturing ready-mixed concrete products and that complies with ASTM C94/C94M requirements for production facilities and equipment.

1. Manufacturer certified in accordance with NRMCA's "Certification of Ready Mixed Concrete Production Facilities."

B. Installer Qualifications: An experienced cast-in-place architectural concrete installer, as evidenced by not less than five consecutive years' experience, specializing in installing cast-in-place architectural concrete similar in material, design, and extent to that indicated for this Project and whose work has resulted in construction with a record of successful in-service performance.

1. Provide written evidence of qualifications and experience.
2. Include locations, descriptions, and photographs of completed projects, including name of architect, substantiating the quality of the installer's experience.

C. Laboratory Testing Agency Qualifications: A testing agency qualified in accordance with ASTM C1077 and ASTM E329 for testing indicated and employing an ACI-certified Concrete Quality Technical Manager.

1. Personnel performing laboratory tests to be an ACI-certified Concrete Strength Testing Technician and Concrete Laboratory Testing Technician, Level I.

2. Testing agency laboratory supervisor to be an ACI-certified Concrete Laboratory Testing Technician, Level II.

8. PRECONSTRUCTION TESTING

- A. Preconstruction Testing Service: Engage a qualified testing agency to perform preconstruction testing on concrete mixtures.

1. Include the following information in each test report:

- a. Admixture dosage rates.
- b. Slump.
- c. Air content.
- d. Seven-day compressive strength.
- e. 28-day compressive strength.
- f. Permeability.

9. DELIVERY, STORAGE, AND HANDLING

- A. Comply with ASTM C94/C94M and ACI 301.

10. FIELD CONDITIONS

- A. Cold-Weather Placement: Comply with Section 033000 "Cast-in-Place Concrete."
- B. Hot-Weather Placement: Comply with Section 033000 "Cast-in-Place Concrete."

2.PRODUCTS

1. CONCRETE, GENERAL

- A. ACI Publications: Comply with ACI 301 unless modified by requirements in the Contract Documents.

2. FORM-FACING MATERIALS

- A. Comply with Section 031000 "Concrete Forming and Accessories" for formwork and other form-facing material requirements, and as specified in this Section.
- B. Source Limitations: Obtain each type of form-facing material from single source from single manufacturer.
- C. Form-Facing Panels

3. REINFORCEMENT ACCESSORIES

- A. Bar Supports: Bolsters, chairs, spacers, and other devices for spacing, supporting, and fastening reinforcing bars and welded-wire fabric in place.
1. Manufacture bar supports in accordance with CRSI's "Manual of Standard Practice."
 2. Where legs of wire bar supports contact forms, use CRSI Class 1, gray, plastic-protected or CRSI Class 2, stainless steel] bar supports.

4. CONCRETE MATERIALS

A. Cementitious Materials:

1. Portland Cement: ASTM C150/C150M, or
2. Blended Cement: ASTM C595
3. Fly Ash: ASTM C618, Class C or F
4. Slag Cement: ASTM C989/C989M, Grade 100 or 120.
5. Silica Fume: ASTM C1240 amorphous silica.

B. Normal-Weight Aggregates: ASTM C33/C33M, coarse aggregate or better, graded. Provide aggregates from single source from single manufacturer.

1. Alkali-Silica Reaction: Comply with one of the following:
 - a. Expansion Result of Aggregate: Not more than 0.04 percent at one year when tested in accordance with ASTM C1293.
 - b. Expansion Results of Aggregate and Cementitious Materials in Combination: Not more than 0.10 percent at 16 days when tested in accordance with ASTM C1567.
 - c. Alkali Content in Concrete: Not more than 4 lb./cu. yd. for moderately reactive aggregate or 3 lb./cu. yd. for highly reactive aggregate, when tested in accordance with ASTM C1293 and categorized in accordance with ASTM C1778, based on alkali content being calculated in accordance with ACI 301.
2. Maximum Coarse-Aggregate Size: 1 inch
3. Gradation: Uniformly graded.

C. Normal-Weight Fine Aggregate: ASTM C33/C33M or ASTM C144, manufactured or natural sand, free of materials with deleterious reactivity to alkali in cement, from same source for entire Project.

D. Air-Entraining Admixture: As specified in Section 033000 "Cast-in-Place Concrete."

E. Chemical Admixtures: As specified in Section 033000 "Cast-in-Place Concrete," and certified by manufacturer to be compatible with other admixtures and that do not contribute water-soluble chloride ions exceeding those permitted in hardened concrete. Do not use calcium chloride or admixtures containing calcium chloride.

F. Water: Potable, complying with ASTM C94/C94M, except free of wash water from mixer washout operations.

5. CURING MATERIALS

- A. Absorptive Cover: AASHTO M 182, Class 2, burlap cloth made from jute or kenaf, weighing approximately 9 oz./sq. yd. when dry.
- B. Moisture-Retaining Cover: ASTM C171, polyethylene film or white burlap-polyethylene sheet.
- C. Waterborne, Membrane-Forming Curing Compound: ASTM C309, Type 1, Class B.
 - 1. For concrete indicated to be sealed, curing compound shall be compatible with sealer.

6. REPAIR MATERIALS

- A. Bonding Agent: ASTM C1059/C1059M, Type II, nonredispersible, acrylic emulsion or styrene butadiene.
- B. Epoxy Bonding Adhesive: ASTM C881/C881M two-component epoxy resin, capable of humid curing and bonding to damp surfaces, of class suitable for application temperature and of grade to suit requirements.
 - 1. Types I and II, for non-load bearing and Types IV and V, for load bearing, for bonding hardened or freshly mixed concrete to hardened concrete.

7. CONCRETE MIXTURES, GENERAL

- A. Obtain each color, size, type, and variety of concrete mixture from single manufacturer with resources to provide cast-in-place architectural concrete of consistent quality in appearance and physical properties.
- B. Prepare design mixtures for each type and strength of cast-in-place architectural concrete proportioned on basis of laboratory trial mixture or field test data, or both, in accordance with ACI 301.
 - 1. Use a qualified independent testing agency for preparing and reporting proposed concrete mixture designs, based on laboratory trial mixtures.
- C. Cementitious Materials: Limit percentage, by weight, of cementitious materials other than portland cement in concrete as follows:
 - 1. Fly Ash or Other Pozzolans: 25 percent by mass.
 - 2. Slag Cement: 50 percent by mass.
 - 3. Silica Fume: 10 percent by mass.
 - 4. Total of Fly Ash or Other Pozzolans, Slag Cement, and Silica Fume: 50 percent by mass, with fly ash or pozzolans not exceeding 25 percent by mass and silica fume not exceeding 10 percent by mass.
 - 5. Total of Fly Ash or Other Pozzolans and Silica Fume: 35 percent by mass with fly ash or pozzolans not exceeding 25 percent by mass and silica fume not exceeding 10 percent by mass.
- D. Admixtures: Use admixtures in accordance with manufacturer's written instructions.

8. CONCRETE MIXING

A. Architectural Concrete:

1. Ready mixed. Measure, batch, mix, and deliver concrete in accordance with ASTM C94/C94M, and furnish batch ticket information.
 - a. Clean equipment used to mix and deliver cast-in-place architectural concrete to prevent contamination from other concrete.
 - b. For mixer capacity of 1 cu. yd. or smaller, continue mixing at least 1-1/2 minutes, but not more than five minutes after ingredients are in mixer, before any part of batch is released.
 - c. For mixer capacity larger than 1 cu. yd., increase mixing time by 15 seconds for each additional 1 cu. yd..
 - d. Provide batch ticket for each batch discharged and used in the Work, indicating Project identification name and number, date, mixture type, mixture time, quantity, and amount of water added. Record approximate location of final deposit in structure.
2. When air temperature is between 85 and 90 deg F, reduce mixing and delivery time from 1-1/2 hours to 75 minutes; when air temperature is above 90 deg F, reduce mixing and delivery time to 60 minutes

3.EXECUTION

1. INSTALLATION OF FORMWORK

- A. Comply with Section 031000 "Concrete Forming and Accessories" for formwork, embedded items, and shoring and reshoring, and as specified in this Section.
- B. Limit deflection of form-facing panels to not exceed ACI 301 requirements.
- C. Limit cast-in-place architectural concrete surface irregularities, as follows:
 1. ACI 301 (ACI 301M) Surface Finish SF-1.0: As-cast concrete texture imparted by form-facing material.
 - a. Patch voids larger than 1-1/2 inches wide or 1/2 inch deep.
 - b. Remove projections larger than 1 inch.
 - c. Tie holes do not require patching.
 - d. Surface Tolerance: ACI 117, Class D.
 - e. Apply to concrete surfaces for metal lap pan deck formed surfaces and those surfaces that are buried or covered with subsequent installed surfaces.
 2. ACI 301 (ACI 301M) Surface Finish SF-2.0: As-cast concrete texture imparted by form-facing material, arranged in an orderly and symmetrical manner with a minimum of seams.
 - a. Patch voids larger than 3/4 inch wide or 1/2 inch deep.
 - b. Remove projections larger than 1/4 inch.
 - c. Patch tie holes.
 - d. Surface Tolerance: ACI 117, Class B.

- e. Locations: Apply to concrete surfaces exposed to public view, to receive a rubbed finish, or to be covered with a coating or covering material applied directly to concrete.
 3. ACI 301 (ACI 301M) Surface Finish SF-3.0:
 - a. Patch voids larger than 3/4 inch wide or 1/2 inch deep.
 - b. Remove projections larger than 1/8 inch.
 - c. Patch tie holes.
 - d. Surface Tolerance: ACI 117 Class A.
 - e. Locations: Apply to concrete surfaces exposed to public view, to receive a rubbed finish, or to be covered with a coating or covering material applied directly to concrete.
- D. Construct forms to result in cast-in-place architectural concrete that complies with ACI 117.
 - E. Seal form joints, chamfers, rustication joints, and penetrations at form ties with form joint tape or form joint sealant to prevent cement paste leakage.
 1. Provide closure backing materials if indented rustication is used over a ribbed form line, and seal joint between rustication strip and form with joint sealant.
 - F. Chamfer exterior corners and edges of cast-in-place architectural concrete.
 - G. Coat contact surfaces of wood rustications and chamfer strips with wood sealer before placing reinforcement, anchoring devices, and embedded items.
 - H. Coat contact surfaces of forms with form-release agent, in accordance with manufacturer's written instructions, before placing reinforcement, anchoring devices, and embedded items.
 - I. Coat contact surfaces of forms with surface retarder, in accordance with manufacturer's written instructions, before placing reinforcement, anchoring devices, and embedded items.
 - J. Place form liners accurately to provide finished surface texture indicated.
 1. Provide solid backing and attach securely to prevent deflection and maintain stability of liners during concreting.
 2. Secure form liners in place using fasteners that will not transfer impressions onto surface of concrete.
 3. Prevent form liners from sagging and stretching in hot weather.
 4. Seal joints of form liners and form-liner accessories to prevent mortar leaks.
 5. Coat form liner with form-release agent.
2. INSTALLATION OF REINFORCEMENT AND ACCESSORIES
 - A. Comply with Section 032000 "Concrete Reinforcing" for fabricating and installing steel reinforcement and accessories.

3. REMOVING AND REUSING FORMS

- A. Formwork for sides of beams, walls, columns, and similar parts of the Work that does not support weight of concrete may be removed after cumulatively curing at not less than 50 deg F for **24** hours after placing concrete. Concrete has to be hard enough to not be damaged by form-removal operations, and curing and protection operations need to be maintained.
 - 1. Schedule form removal to maintain surface appearance that matches approved design reference sample, field sample panels, or mockups.
 - 2. Leave formwork for beam soffits, joists, slabs, and other structural elements that support weight of concrete in place until concrete has achieved at least 80 percent of its 28-day design compressive strength.
 - 3. Remove forms only if shores have been arranged to permit removal of forms without loosening or disturbing shores.
 - 4. Cut off and grind glass-fiber-reinforced plastic form ties flush with surface of concrete.
- B. Clean and repair surfaces of forms to be reused in the Work.
 - 1. Split, frayed, delaminated, or otherwise damaged form-facing material are unacceptable for exposed surfaces.
 - 2. Apply new form-release agent.
- C. When forms are reused, clean surfaces, remove fins and laitance, and tighten to close joints.
 - 1. Align and secure joints to avoid offsets.
 - 2. Do not use patched forms for cast-in-place architectural concrete surfaces.

4. JOINTS

- A. Construction Joints: Install construction joints true to line, with faces perpendicular to surface plane of cast-in-place architectural concrete, so strength and appearance of concrete are not impaired, at locations indicated or as approved by Architect.
 - 1. Place joints perpendicular to main reinforcement. Continue reinforcement across construction joints unless otherwise indicated.
 - 2. Form keyed joints as indicated. Embed keys at least 1-1/2 inches into concrete. Align construction joint within rustications attached to form-facing material.
 - 3. Locate joints for beams, slabs, joists, and girders in the middle third of spans. Offset joints in girders a minimum distance of twice the beam width from a beam-girder intersection.
 - 4. Locate horizontal joints in walls and columns at underside of floors, slabs, beams, and girders and at the top of footings or floor slabs.
 - 5. Space vertical joints in walls as indicated. Locate joints beside piers integral with walls, near corners, and in concealed locations where possible.
 - 6. Use bonding agent at locations where fresh concrete is placed against hardened or partially hardened concrete surfaces.
- B. Contraction Joints: Form weakened-plane contraction joints true to line, with faces perpendicular to surface plane of cast-in-place architectural concrete, so strength and appearance of concrete are not impaired, at locations indicated on Drawings or as approved by Architect.

5. CONCRETE PLACEMENT

- A. Comply with Section 033000 "Cast-in-Place Concrete."

6. FINISHING FORMED SURFACES

- A. Comply with Section 033000 "Cast-in-Place Concrete."

- B. Architectural Concrete Finish: Match Architect's design reference sample, identified and described as indicated, to satisfaction of Architect.

- C. As-Cast Surface Finishes: Comply with Section 033000 "Cast-in-Place Concrete" for the following:

1. ACI 301 Surface Finish-1.0 (SF-1.0).
2. ACI 301 Surface Finish-2.0 (SF-2.0).
3. ACI 301 Surface Finish-3.0 (SF-3.0).

- D. Final Concrete Finish: Comply with Section 033000 "Cast-in-Place Concrete" for the following:

1. Smooth-rubbed finish.
2. Grout-cleaned rubbed finish.
3. Cork-floated finish.
4. Abrasive-blast finish.
5. Scrubbed finish.
6. High-pressure water-jet finish.
7. Bushhammer finish.

- E. Form-Liner Finish: Produce a textured surface free of pockets, streaks, and honeycombs, and of uniform appearance, color, and texture.

- F. Maintain uniformity of architectural concrete finishes over construction joints unless otherwise indicated.

7. CONCRETE CURING

- A. Comply with Section 033000 "Cast-in-Place Concrete" using identical curing procedures to that used for field sample panels or mockups.

8. REPAIR

- A. Comply with ACI 301.

- B. Repair damaged finished surfaces of cast-in-place architectural concrete when repairing is approved by Architect.

- C. Match repairs to color, texture, and uniformity of surrounding surfaces and to repairs on approved field sample panels or mockups.

- D. Remove and replace cast-in-place architectural concrete that cannot be repaired to Architect's approval.

9. FIELD QUALITY CONTROL

- A. Comply with Section 033000 "Cast-in-Place Concrete."

10. CLEANING

- A. Clean cast-in-place architectural concrete surfaces after finish treatment to remove stains, markings, dust, and debris.
- B. Wash and rinse surfaces in accordance with concrete finish applicator's written instructions.
 - 1. Protect other Work from staining or damage due to cleaning operations.
 - 2. Do not use cleaning materials or processes that could change the appearance of cast-in-place architectural concrete finishes.

11. PROTECTION

- A. Protect corners, edges, and surfaces of cast-in-place architectural concrete from damage; use guards and barricades.
- B. Protect cast-in-place architectural concrete from staining, laitance, and contamination during remainder of construction period.

12. FINAL ACCEPTANCE

- A. Final acceptance of completed architectural concrete Work will be determined by Architect by comparing approved design reference sample, field sample panels, or mockups with installed Work, when viewed at a distance of 20 feet.

END OF SECTION 033300

SECTION 036000 – POST INSTALLED ANCHORS

1. GENERAL

1. RELATED DOCUMENTS

- A. Drawings and general provisions of the Contract, including General and Supplementary Conditions and Division 01 Specification Sections, apply to this Section. If differing requirements are identified elsewhere (in these specifications or on drawings or separate instructions), the more stringent requirement shall be met.

2. SUMMARY

- A. Section includes post installed concrete anchors requirements for the following:

- 1. Mechanical Anchors.
- 2. Adhesive Anchors.

- B. Related Sections:

- 1. Division 03 Section "Cast-In-Place Concrete".
- 2. Division 04 Section "Unit Masonry".
- 3. Division 05 Section "Structural Steel Framing".

3. DEFINITION

- A. Post Installed Anchors: Anchors installed into hardened concrete or fully constructed hollow or grouted masonry.

4. REFERENCE MATERIAL

- A. ACI 318 – Building Code Requirements for Structural Concrete
- B. ACI 355.2 – Standard for Evaluating the Performance of Post-Installed Mechanical Anchors in Concrete
- C. ASTM A36 – Standard Specification for Carbon Structural Steel
- D. ASTM A153 – Standard Specification for Zinc Coating (Hot-Dip) on Iron and Steel Hardware
- E. ASTM A193 – Standard Specification for Alloy-Steel and Stainless Steel Bolting Materials for High-Temperature Service
- F. ASTM C881 – Standard Specification Epoxy-Resin-Based Bonding Systems for Concrete
- G. ASTM E488 – Standard Test Methods for Strength of Anchors in Concrete and Masonry Elements
- H. ASTM E1512 – Standard Test Methods for Testing Bond Performance of Bonded Anchors
- I. ASTM F593 – Standard Specification for Stainless Steel Bolts, Hex Cap Screws, and Studs
- J. ICC-ES AC01 – Acceptance Criteria for Expansion Anchors in Masonry Elements
- K. ICC-ES AC58 – Acceptance Criteria for Adhesive Anchors in Masonry Elements
- L. ICC-ES AC60 – Acceptance Criteria for Anchors in Unreinforced Masonry Elements
- M. ICC-ES AC106 – Acceptance Criteria for Predrilled Fasteners (Screw Anchors) in Concrete or Masonry Elements
- N. ICC-ES AC193 – Acceptance Criteria for Mechanical Anchors in Concrete Elements
- O. ICC-ES AC308 – Acceptance Criteria for Post-Installed Adhesive Anchors in Concrete Elements

5. SUBMITTAL
 - A. General: Submit in accordance with Conditions of the Contract and Division 1 Submittal Procedures Section.
 1. Product specifications with recommended design values and physical characteristics for epoxy dowels, expansion and undercut anchors.
 2. Quality Assurance Submittals:
 - a. Test Reports: Certified test reports showing compliance with specified performance characteristics and physical properties.
 - b. Certificates
 - 1) ICC ES Evaluation Reports
 - B. Manufacturer's installation instructions.
 - C. Installer Qualifications & Procedures: Submit installer qualifications to special inspector for approval prior to commencement of work.
6. QUALITY ASSURANCE
 - A. Installer(s) Training:
 1. Product Manufacturer's certificate for each installer certifying they have been trained on the means and methods for installing the particular anchor.
 - B. For horizontal and upwardly inclined adhesive installations, the installer shall be certified by an ACI/CRSI Adhesive Anchor Installing Certification Program or equivalent.
 - C. Certifications: Unless otherwise authorized by the Engineer, anchors shall have one of the following certifications.
 1. ICC ES Evaluation Report indicating conformance with current applicable ICC ES Acceptance Criteria.
7. DELIVERY, STORAGE, AND HANDLING
 - A. Deliver products to job site in manufacturer's or distributor's packaging undamaged, complete with installation instructions.
 - B. General: Comply with Division 1 Section-Product Storage and Handling Requirements
 1. Store anchors in accordance with manufacturer's recommendations.

2.PRODUCTS

1. MANUFACTURER
 - A. All products are based on Hilti Corporation.
 - B. Substitution:
 1. Upon approval by the engineer, the installer may substitute a product by a different manufacturer, provided that the manufacturer submits calculations signed and sealed by an engineer registered in the state of the project's location.

- a. These calculations must show that the strength of the substituted anchor meets or exceeds the strength of the specified anchor at each application in the project where a substituted anchor is proposed, with consideration for combined stress and any applicable reduction factors.
 - C. The substitution request and submittal shall be made a minimum of 2 weeks prior to planned installation of the anchors.
 - D. The finish of the anchor shall remain the same as specified.
2. MECHANICAL ANCHORS
- A. Torque Controlled (TC) Anchors. Hilti Kwik Bolt TZ2 is a torque controlled expansion anchor suited to seismic and cracked concrete applications.
 1. Size: As indicated on drawings
 2. Finish: Plain carbon steel or Stainless Steel type 304 (316) as indicated on drawings.
 - B. Screw Anchors: Hilti Kwik HUS-EZ anchors are comprised of a body with hex washer head.
 1. Size: As indicated on drawings
 2. Finish: As indicated on drawings
 - C. Sleeve Anchors: Hilti HLC Sleeve Anchor are mechanical expansion anchors consisting of an externally threaded stud with an expanding sleeve for use in concrete and hollow and solid masonry base material.
 1. Size: As indicated on drawings
 2. Finish: As indicated on drawings
3. ADHESIVE ANCHORS
- A. In contract documents adhesive anchors may be generically referred to as epoxy anchors. Where this is the case the word adhesive should be substituted for epoxy.
 - B. Adhesive anchors used in concrete under a tension condition cannot be installed until after the concrete has cured for a minimum 21 days in accordance with ACI 17.4.5.2.
 - C. Concrete Anchor
 1. Hilti HIT-RE 500-V3 is a high strength, two part epoxy adhesive.
 - a. Base material temperature range: 23 degrees up to 120 degrees Fahrenheit.
 - b. Size: As indicated on drawings, up to 1.25" diameter maximum.
 - c. Finish: As indicated on drawings
 - d. Anchor material: HAS Threaded Rod Standard ISO 898 Class 5.8, and Deformed Reinforcing Bars.
 2. Hilti HIT HY 200 V3 is a two-component hybrid adhesive.
 - a. Base material temperature range: 14 degrees up to 104 degrees Fahrenheit.
 - b. Size: As indicated on drawings, up to 1" diameter maximum.
 - c. Finish: As indicated on drawings
 - d. Anchor material: HAS Threaded Rod Standard ISO 898 Class 5.8, and Deformed Reinforcing Bars.
 3. Hilti HIT HY 200 V3 Safeset is a two-component hybrid adhesive.
 - a. Base material temperature range: 14 degrees up to 104 degrees Fahrenheit.

- b. Size: As indicated on drawings, up to 1" diameter maximum.
 - c. Finish: As indicated on drawings
 - d. Anchor material based on cleaning:
 - 1) No cleaning of hole:
 - a) HIT-Z, HIT-Z-R Threaded Rods
 - 2) Automatic cleaning of hole:
 - a) HAS Threaded Rod Standard ISO 898 Class 5.8, and Deformed Reinforcing Bars.
- D. Masonry Anchor:
- 1. Hilti HIT HY-270 System is a hybrid adhesive consisting of a dual cylinder adhesive refill pack, a mixing nozzle, a screen tube, and either a threaded rod or rebar.
 - a. Size: As indicated on drawings
 - b. Finish: As indicated on drawings
 - c. Anchor Rod: HAS-E Standard ISO 898 Class 5.8.
 - d. Use: Hollow brick, hollow concrete masonry block, or grouted solid concrete masonry block.
 - 2. Hilti HIT HY 200 is a two-component hybrid adhesive.
 - a. Base material temperature range: 14 degrees up to 104 degrees Fahrenheit.
 - b. Size: As indicated on drawings, up to 1" diameter maximum.
 - c. Finish: As indicated on drawings
 - d. Anchor material: HY200 HAS Threaded Rod Standard ISO 898 Class 5.8, and Deformed Reinforcing Bars.
 - e. Use: Solid or grouted solid masonry only.

3.EXECUTION

1. POST INSTALLED ANCHORS

- A. All installation into concrete and masonry shall be done in accordance with manufacturer's ICC-ES report.
- B. Drilling:
 - 1. Drill holes with rotary impact hammer drills. Drill bits shall be of diameters as specified by the anchor manufacturer. Unless otherwise shown on the Drawings, all holes shall be drilled perpendicular to the concrete surface.
 - 2. Embedded Items: Identify position of reinforcing steel and other embedded items prior to drilling holes for anchors. Exercise care in coring or drilling to avoid damaging existing reinforcing or embedded items. Notify the Engineer if reinforcing steel or other embedded items are encountered during drilling. Take precautions as necessary to avoid damaging prestressing tendons, electrical and telecommunications conduit, and gas lines.
 - 3. Base Material Strength: Unless otherwise specified, do not drill holes in concrete or masonry until concrete, mortar, or grout has met Manufacturer's specifications.
- C. Torque Controlled Anchors and Sleeve Anchors: Protect threads from damage during anchor installation. Set anchors to manufacturer's recommended torque, using a torque wrench. Following attainment of 10% of the specified torque, 100% of the specified torque shall be reached within 7 or fewer complete turns of the nut. If the specified torque is not achieved within the required number of turns, the anchor shall be removed and replaced unless otherwise directed by the Engineer.
- D. Screw Anchors: Install screw anchors to a snug tight condition unless noted otherwise.

- E. Adhesive Anchors: Clean all holes per manufacturer instructions to remove loose material and drilling dust prior to installation of adhesive. Inject adhesive into holes proceeding from the bottom of the hole and progressing toward the surface in such a manner as to avoid introduction of air pockets in the adhesive. Follow manufacturer recommendations to ensure proper mixing of adhesive components. Sufficient adhesive shall be injected in the hole to ensure that the annular gap is filled to the surface. Remove excess adhesive from the surface. Shim anchors with suitable device to center the anchor in the hole. Do not disturb or load anchors before manufacturer specified cure time has elapsed.

2. FIELD QUALITY CONTROL

- A. Testing and Inspecting: Engage a special inspector and qualified testing and inspecting agency to perform field tests and inspections and prepare test reports.
- B. Continuous special Inspection of post-installed concrete and masonry anchors shall be provided as required by ICC-ES evaluation reports. This service shall be performed by personnel independent of the Manufacturer or Contractor so as to prevent a conflict of interest.
- C. The Engineer or Architect of Record may require pullout or shear tests, in addition to Special Inspection, to determine the adequacy of anchors. A field testing program shall be established by the independent testing and inspecting agency and/or Engineer of Record and performed in accordance with appropriate ASTM test standards. Field tests shall be non-destructive whenever possible.

END OF SECTION 036000

SECTION 040120.63 - BRICK MASONRY REPAIR

PART 1 - GENERAL

1.1 SUMMARY

1. Masonry materials.

B. Related Requirements:

1. Section 040110 "Masonry Cleaning" for cleaning and paint removal existing masonry.
2. Section 040120.64 "Brick Masonry Repointing" for repointing existing brickwork.
3. Section 079200 "Joint Sealants" for joint sealants, joint fillers, and sealant-joint preparation for repaired masonry.

1.2 ACTION SUBMITTALS

A. Product Data: For each type of product.

1. Include construction details, material descriptions, dimensions of individual components and profiles, and finishes.
2. Include recommendations for product application and use.

B. Shop Drawings:

1. Include plans, elevations, sections, and locations of replacement bricks on the structure, showing relation of existing and new or relocated units.
2. Show provisions for expansion joints or other sealant joints.
3. Show provisions for flashing, lighting fixtures, conduits, and weep holes as required.
4. Show locations of scaffolding and points of scaffolding in contact with masonry. Include details of each point of contact or anchorage.

C. Samples for Initial Selection: For the following:

1. Colored Mortar: Submit sets of mortar that will be left exposed in the form of sample mortar strips, **6 inches** long by **1/4 inch** wide, set in aluminum or plastic channels.
 - a. Have each set contain a close color range of at least three Samples of different mixes of colored sands and cements that produce a mortar matching existing, cleaned mortar when cured and dry.
2. Sand Types Used for Mortar: Minimum **8 oz.** of each in plastic screw-top jars.
3. Patching Compound: Submit sets of patching compound Samples in the form of plugs (patches in drilled holes) in sample units of masonry representative of the

range of masonry colors on the building.

- a. Have each set contain a close color range of at least three Samples of different mixes of patching compound that matches the variations in existing masonry when cured and dry.
4. Include similar Samples of accessories involving color selection.

1.3 INFORMATIONAL SUBMITTALS

- A. Qualification Data: For brick masonry repair specialist including field supervisors and workers.

1.4 QUALITY ASSURANCE

- A. Brick Masonry Repair Specialist Qualifications: Engage an experienced brick masonry repair firm to perform Work of this Section. Firm is to have completed work similar in material, design, and extent to that indicated for this Project with a record of successful in-service performance. Experience in only installing masonry is insufficient experience for masonry repair work.
 1. Field Supervision: Brick masonry repair specialist firm is to maintain experienced full-time supervisors on Project site during times that brick masonry repair work is in progress.
 2. Brick Masonry Repair Workers: When bricks are being patched, at least one worker per crew should be trained and certified by manufacturer of patching compound to apply its products performing the work of brick repairs.
- B. Brick-Cleaning Specialist Firms: A firm that provides masonry cleaning, including masonry cleaners that have been used for similar applications with successful results, and is manufacturer authorized for consultation and Project-site inspection, preconstruction product testing, and on-site assistance.
- C. Quality-Control Program: Prepare a written quality-control program for this Project to systematically demonstrate the ability of personnel to properly follow methods and use materials and tools without damaging masonry. Include provisions for supervising performance and preventing damage.

1.5 FIELD CONDITIONS

- A. Weather Limitations: Proceed with installation only when existing and forecasted weather conditions permit brick masonry repair work to be performed in accordance with product manufacturers' written instructions and specified requirements.
- B. Temperature Limits: Repair brick masonry only when air temperature is between **40 and 90 deg F** and is predicted to remain so for at least seven days after completion of the Work unless otherwise indicated.

- C. Cold-Weather Requirements: Comply with the following procedures for masonry repair unless otherwise indicated:
 - 1. When air temperature is below **40 deg F**, heat mortar ingredients, masonry repair materials, and existing masonry walls to produce temperatures between **40 and 120 deg F**.
 - 2. When mean daily air temperature is below **40 deg F**, provide enclosure and heat to maintain temperatures above **32 deg F** within the enclosure for seven days after repair.
- D. Hot-Weather Requirements: Protect masonry repairs when temperature and humidity conditions produce excessive evaporation of water from mortar and repair materials. Provide artificial shade and wind breaks, and use cooled materials as required to minimize evaporation. Do not apply mortar to substrates with temperatures of **90 deg F** and above unless otherwise indicated.
- E. For manufactured repair materials, perform work within the environmental limits set by each manufacturer.

PART 2 - PRODUCTS

2.1 PERFORMANCE REQUIREMENTS

- A. Thermal Movements: Allow for thermal movements from ambient and surface temperature changes.
 - 1. Temperature Change: **120 deg F**, ambient; **180 deg F**, material surfaces.

2.2 MASONRY MATERIALS

- A. Masonry Materials: Face brick, required to complete brick masonry repair work.
 - 1. Brick Matching Existing: Units with colors, color variation within units, surface texture, size, and shape that match existing brickwork and with physical properties within 10 percent of those determined from preconstruction testing of selected existing units.
 - a. For existing brickwork that exhibits a range of colors or color variation within units, provide brick that proportionally matches that range and variation rather than brick that matches an individual color within that range.
 - 2. Special Shapes:
 - a. Provide molded, 100 percent solid shapes for applications where core holes or "frogs" could be exposed to view or weather when in final position and where shapes produced by sawing would result in sawed surfaces being exposed to view.

- b. Provide specially ground units, shaped to match patterns, for arches and where indicated.
 - c. Mechanical chopping or breaking brick, or bonding pieces of brick together by adhesive, are unacceptable procedures for fabricating special shapes.
3. Tolerances as Fabricated: In accordance with tolerance requirements in ASTM C216, Type FBS.

2.3 ACCESSORY MATERIALS

- A. Setting Buttons and Shims: Resilient plastic, nonstaining to masonry, sized to suit joint thicknesses and bed depths of bricks, less the required depth of pointing materials unless removed before pointing.
- B. Masking Tape: Nonstaining, nonabsorbent material; compatible with mortar, joint primers, sealants, and surfaces adjacent to joints; and that easily comes off entirely, including adhesive.
- C. Other Products: Select materials and methods of use based on the following, subject to approval of a mockup:
 1. Previous effectiveness in performing the work involved.
 2. Minimal possibility of damaging exposed surfaces.
 3. Consistency of each application.
 4. Uniformity of the resulting overall appearance.
 5. Do not use products or tools that could leave residue on surfaces.

PART 3 - EXECUTION

3.1 FIELD QUALITY CONTROL

- A. Testing Agency: Owner will engage a qualified testing agency to perform tests and inspections. Allow inspectors use of lift devices and scaffolding, as needed, to perform inspections.
- B. Architect's Project Representatives: Architect will assign Project representatives to help carry out Architect's responsibilities at the site, including observing progress and quality of portion of the Work completed. Allow Architect's Project representatives use of lift devices and scaffolding, as needed, to observe progress and quality of portion of the Work completed.
- C. Notify inspectors and Architect's Project representatives in advance of times when lift devices and scaffolding will be relocated. Do not relocate lift devices and scaffolding until inspectors and Architect's Project representatives have had reasonable opportunity to make inspections and observations of work areas at lift device or scaffold location.

Intersect Studio, LLC
23046

Kalamazoo Crosstown
Parkway Facility
Kalamazoo, Michigan

END OF SECTION 040120.63

SECTION 042200 - CONCRETE UNIT MASONRY

1. PART 1 - GENERAL

1. RELATED DOCUMENTS

- A. Drawings and general provisions of the Contract, including General and Supplementary Conditions and Division 01 Specification Sections, apply to this Section. If differing requirements are identified elsewhere (in these specifications or on drawings or separate instructions), the more stringent requirement shall be met.

2. SUMMARY

1. Masonry-joint reinforcement.
2. Miscellaneous masonry accessories.
3. Masonry-cell insulation.

B. Products Installed, but Not Furnished, under This Section:

1. Steel lintels and steel shelf angles in accordance with Section 055000 "Metal Fabrications" in concrete unit masonry.

C. Related Requirements:

1. Section 031000 "Concrete Forming and Accessories" for dovetail slots for masonry anchors.
2. Section 051200 "Structural Steel Framing" for installing anchor sections of adjustable masonry anchors for connecting to structural steel frame.
3. Section 076200 "Sheet Metal Flashing and Trim" for sheet metal flashing and for furnishing manufactured reglets installed in masonry joints.

3. ACTION SUBMITTALS

A. Product Data:

1. For each type of product.

B. Sustainable Design Submittals:

C. Shop Drawings: For the following:

1. Masonry Units: Show sizes, profiles, coursing, and locations of special shapes.
2. Reinforcing Steel: Detail bending, lap lengths, and placement of unit masonry reinforcing bars. Comply with ACI 315. Show elevations of reinforced walls.

3. Lintel design and types required.
 4. Fabricated Flashing: Detail corner units, end-dam units, and other special applications.
- D. Samples for Verification: For each type and color of the following:
1. Exposed CMUs.
 2. Pre-faced CMUs.
4. INFORMATIONAL SUBMITTALS
- A. Material Certificates: For each type and size of the following:
1. Masonry units.
 - a. Include data on material properties, material test reports substantiating compliance
 - b. For masonry units used in structural masonry, include data and calculations establishing average net-area compressive strength of units.
 2. Integral water repellent used in CMUs, if not surface treated.
 3. Cementitious materials. Include name of manufacturer, brand name, and type.
 4. Mortar admixtures.
 5. Preblended, dry mortar mixes. Include description of type and proportions of ingredients.
 6. Grout mixes. Include description of type and proportions of ingredients.
 7. Reinforcing bars.
 8. Joint reinforcement.
 9. Anchors, ties, and metal accessories.
- B. Mix Designs: For each type of mortar and grout. Include description of type and proportions of ingredients.
1. Include test reports for mortar mixes required to comply with property specification. Test in accordance with ASTM C109/C109M for compressive strength, ASTM C1506 for water retention, and ASTM C91/C91M for air content.
 2. Include test reports, in accordance with ASTM C1019, for grout mixes required to comply with compressive strength requirement.
- C. Statement of Compressive Strength of Masonry: For each combination of masonry unit type and mortar type, provide statement of average net-area compressive strength of masonry units, mortar type, and resulting net-area compressive strength of masonry

determined in accordance with TMS 402/602.

D. Weather Procedures:

1. Cold-Weather Procedures: Detailed description of methods, materials, and equipment to be used to comply with requirements.
2. Hot-Weather Procedures: Detailed description of methods, materials, and equipment to be used to comply with requirements.

5. QUALITY ASSURANCE

- A. Project team craftworkers of the Masonry Contractor assigned to Project will be required to have the International Masonry Institute - Flashing Training or equal and to provide evidence of certificate or a letter of the firm's commitment to enroll key project personnel in the training program prior to the start of Project.
- B. Project team craftworkers of the Masonry Contractor assigned to Project will be required to have the International Masonry Institute - Grouting and Reinforcing Training or equal and to provide evidence of certificate or a letter of the firm's commitment to enroll key project personnel in the training program prior to the start of Project.
- C. Testing Agency Qualifications: Qualified in accordance with ASTM C1093 for testing indicated.

6. FIELD CONDITIONS

- A. Protection of Masonry: During construction, cover tops of walls, projections, and sills with waterproof sheeting at end of each day's work. Cover partially completed masonry when construction is not in progress.
 1. Extend cover a minimum of 24 inches down both sides of walls, and hold cover securely in place.
- B. Do not apply uniform floor or roof loads for at least 12 hours and concentrated loads for at least three days after building masonry walls or columns.
- C. Stain Prevention: Prevent grout, mortar, and soil from staining the face of masonry to be left exposed or painted. Immediately remove grout, mortar, and soil that come in contact with such masonry.
 1. Protect base of walls from rain-splashed mud and from mortar splatter by spreading coverings on ground and over wall surface.
 2. Protect sills, ledges, and projections from mortar droppings.
 3. Protect surfaces of window and door frames, as well as similar products with painted and integral finishes, from mortar droppings.
 4. Turn scaffold boards near the wall on edge at the end of each day to prevent rain from splashing mortar and dirt onto completed masonry.

- D. Cold-Weather Requirements: Do not use frozen materials or materials mixed or coated with ice or frost. Do not build on frozen substrates. Remove and replace unit masonry damaged by frost or by freezing conditions. Comply with cold-weather construction requirements contained in TMS 402/602.
 - 1. Cold-Weather Cleaning: Use liquid cleaning methods only when air temperature is 40 deg F and higher and will remain so until masonry has dried, but not less than seven days after completing cleaning.
- E. Hot-Weather Requirements: Comply with hot-weather construction requirements contained in TMS 402/602.

2. PART 2 - PRODUCTS

1. PERFORMANCE REQUIREMENTS

- A. Provide unit masonry that develops indicated net-area compressive strengths at 28 days.
 - 1. Determine net-area compressive strength of masonry from average net-area compressive strengths of masonry units and mortar types (unit-strength method) in accordance with Tables 1 and 2 in TMS 402/602.
- B. Regulatory Requirements: Comply with the provisions of the following codes, specifications, and standards, except as otherwise shown or specified:
 - 1. TMS 402/602:
 - a. Maintain one copy of the standard in Project field office at all times during construction. Contractor's supervisory personnel are to be thoroughly familiar with this material as it applies to Project.

2. TIES AND ANCHORS

- B. General: Ties and anchors extend at least 1-1/2 inches into masonry but with at least a 5/8-inch cover on outside face.
- C. Materials: Provide ties and anchors specified in this article that are made from materials that comply with the following unless otherwise indicated
 - 1. Mill-Galvanized, Carbon-Steel Wire: ASTM A82/A82M, with ASTM A641/A641M, Class 1 coating.
 - 2. Galvanized-Steel Sheet: ASTM A653/A653M, Commercial Steel, G60 zinc coating.
 - 3. Steel Sheet, Galvanized after Fabrication: ASTM A1008/A1008M, Commercial Steel, with ASTM A153/A153M, Class B coating.
 - 4. Steel Plates, Shapes, and Bars: ASTM A36/A36M.

5. Steel Plates, Shapes, and Bars: ASTM A36/A36M

- D. Adjustable Anchors for Connecting to Structural Steel Framing: Provide anchors that allow vertical or horizontal adjustment but resist tension and compression forces perpendicular to plane of wall.
- E. Adjustable Anchors for Connecting to Concrete: Provide anchors that allow vertical or horizontal adjustment but resist tension and compression forces perpendicular to plane of wall.
- F. Partition Top Anchors: 0.105-inch-thick metal plate with a 3/8-inch-diameter metal rod 6 inches long welded to plate and with closed-end plastic tube fitted over rod that allows rod to move in and out of tube. Fabricate from steel, hot-dip galvanized after fabrication.
- G. Rigid Anchors: Fabricate from steel bars 1-1/2 inches wide by 1/4 inch thick by 24 inches long, with ends turned up 2 inches or with cross pins unless otherwise indicated.

3. CONCRETE MASONRY UNITS

- B. Shapes: Provide shapes indicated and as follows, with exposed surfaces matching exposed faces of adjacent units unless otherwise indicated
- C. CMUs: ASTM C90
 - 1. Unit Compressive Strength: Provide units with minimum average net-area compressive strength as indicated on drawings.
 - 2. Density Classification: Medium weight or Normal weight unless otherwise indicated.
 - 3. Size (Width): Manufactured to dimensions 3/8 inch less-than-nominal dimensions.
 - 4. Exposed Faces: Provide color and texture matching the range represented by Architect's sample.
 - 5. Faces to Receive Plaster: Where units are indicated to receive a direct application of plaster, provide textured-face units made with gap-graded aggregates

4. MORTAR AND GROUT MATERIALS

- B. Portland Cement: ASTM C150/C150M, Type I or II, except Type III may be used for cold-weather construction. Provide natural color or white cement as required to produce mortar color indicated. Alkali content is not more than 0.1 percent when tested in accordance with ASTM C114.
- C. Hydrated Lime: ASTM C207, Type S.

- D. Portland Cement-Lime Mix: Packaged blend of portland cement and hydrated lime containing no other ingredients.
- E. Masonry Cement: ASTM C91/C91M.
- F. Mortar Cement: ASTM C1329/C1329M
- G. Aggregate for Mortar: ASTM C144.
- H. Aggregate for Grout: ASTM C404

- I. Cold-Weather Admixture: Nonchloride, noncorrosive, accelerating admixture complying with ASTM C494/C494M, Type C, and recommended by manufacturer for use in masonry mortar of composition indicated.

5. MISCELLANEOUS MASONRY ACCESSORIES

- A. Compressible Filler: Premolded filler strips complying with ASTM D1056, Grade 2A1; compressible up to 35 percent; of width and thickness indicated; formulated from neoprene urethane or PVC.
- B. Preformed Control-Joint Gaskets: Made from styrene-butadiene-rubber compound, complying with ASTM D2000, Designation M2AA-805 or and designed to fit standard sash block and to maintain lateral stability in masonry wall; size and configuration as indicated.
- C. Bond-Breaker Strips: Asphalt-saturated felt complying with ASTM D226/D226M, Type I (No. 15 asphalt felt).

3. PART 3 - EXECUTION

1. INSTALLATION, GENERAL

- A. Build chases and recesses to accommodate items specified in this and other Sections.
- B. Leave openings for equipment to be installed before completing masonry. After installing equipment, complete masonry to match construction immediately adjacent to opening.
- C. Use full-size units without cutting if possible. If cutting is required to provide a continuous pattern or to fit adjoining construction, cut units with motor-driven saws; provide clean, sharp, unchipped edges. Allow units to dry before laying unless wetting of units is specified. Install cut units with cut surfaces and, where possible, cut edges concealed.
- D. Exposed Masonry: Mix units to produce uniform blend of colors and textures.
- E. Where existing masonry occurs, match coursing, bonding, color, and texture of existing masonry.

- F. Temperature Control: Perform temperature-sensitive construction procedures while masonry Work is progressing. Temperature ranges indicated below apply to air temperatures existing at time of installation except for grout. For grout, temperature ranges apply to anticipated minimum night temperatures. In heating mortar and grout materials, maintain mixing temperature selected within 10 deg F.
1. 40 to 32 Deg F (4 to 0 Deg C):
 - a. Mortar: Heat mixing water to produce mortar temperature between 40 and 120 deg F.
 - b. Grout: Follow normal masonry procedures.
 2. 32 to 25 Deg F (0 to Minus 4 Deg C):
 - a. Mortar: Heat mixing water and sand to produce mortar temperatures between 40 and 120 deg F; maintain temperature of mortar on boards above freezing.
 - b. Grout: Heat grout materials to 90 deg F to produce in-place grout temperature of 70 deg F at end of workday.
 3. 25 to 20 Deg F (Minus 4 to 7 Deg C):
 - a. Mortar: Heat mixing water and sand to produce mortar temperatures between 40 and 120 deg F; maintain temperature of mortar on boards above freezing.
 - b. Grout: Heat grout materials to 90 deg F to produce in-place grout temperature of 70 deg F at end of workday.
 - c. Heat both sides of walls under construction using salamanders or other heat sources.
 - d. Use windbreaks or enclosures when wind is in excess of 15 mph.
 4. 20 Deg F (Minus 7 Deg C) and Below:
 - a. Mortar: Heat mixing water and sand to produce mortar temperatures between 40 and 120 deg F.
 - b. Grout: Heat grout materials to 90 deg F to produce in-place grout temperature of 70 deg F at end of workday.
 - c. Masonry Units: Heat masonry units so that they are above 20 deg F at time of laying.
 - d. Provide enclosure and auxiliary heat to maintain an air temperature of at least 40 deg F for 24 hours after laying units.
 5. Do not heat water for mortar and grout to above 160 deg F.
- G. Masonry Protection: Protect completed masonry and masonry not being worked on in the following manner. Temperature ranges indicated apply to mean daily air

temperatures except for grouted masonry. For grouted masonry, temperature ranges apply to anticipated minimum night temperatures.

1. 40 to 32 Deg F (4 to 0 Deg C): Protect masonry from rain or snow for at least 24 hours by covering with weather-resistive membrane.
2. 32 to 25 Deg F (0 to Minus 4 Deg C): Completely cover masonry with weather-resistive membrane for at least 24 hours.
3. 25 to 20 Deg F (Minus 4 to 7 Deg C): Completely cover masonry with weather-resistive insulating blankets or similar protection for at least 24 hours, 48 hours for grouted masonry.
4. 20 Deg F (Minus 7 Deg C) and Below: Except as otherwise indicated, maintain masonry temperature above 32 deg F (0 deg C) for 24 hours using enclosures and supplementary heat, electric heating blankets, infrared lamps or other methods proven to be satisfactory. For grouted masonry, maintain heated enclosure to 40 deg F for 48 hours.

2. TOLERANCES

A. Dimensions and Locations of Elements:

1. For dimensions in cross section or elevation, do not vary by more than plus 1/2 inch or minus 1/4 inch.
2. For location of elements in plan, do not vary from that indicated by more than plus or minus 1/2 inch.
3. For location of elements in elevation, do not vary from that indicated by more than plus or minus 1/4 inch in a story height or 1/2 inch total.

B. Lines and Levels:

1. For bed joints and top surfaces of bearing walls, do not vary from level by more than 1/4 inch in 10 ft., or 1/2 inch maximum.
2. For conspicuous horizontal lines, such as lintels, sills, parapets, and reveals, do not vary from level by more than 1/8 inch in 10 ft., 1/4 inch in 20 ft., or 1/2 inch maximum.
3. For vertical lines and surfaces, do not vary from plumb by more than 1/4 inch in 10 ft., 3/8 inch in 20 ft., or 1/2 inch maximum.
4. For conspicuous vertical lines, such as external corners, door jambs, reveals, and expansion and control joints, do not vary from plumb by more than 1/8 inch in 10 ft., 1/4 inch in 20 ft., or 1/2 inch maximum.
5. For lines and surfaces, do not vary from straight by more than 1/4 inch in 10 ft., 3/8 inch in 20 ft., or 1/2 inch maximum.
6. For vertical alignment of exposed head joints, do not vary from plumb by more than 1/4 inch in 10 ft. or 1/2 inch maximum.

7. For faces of adjacent exposed masonry units, do not vary from flush alignment by more than 1/16 inch.

C. Joints:

1. For bed joints, do not vary from thickness indicated by more than plus or minus 1/8 inch, with a maximum thickness limited to 1/2 inch.
2. For exposed bed joints, do not vary from bed-joint thickness of adjacent courses by more than 1/8 inch.
3. For head and collar joints, do not vary from thickness indicated by more than plus 3/8 inch or minus 1/4 inch.
4. For exposed head joints, do not vary from thickness indicated by more than plus or minus 1/8 inch.

3. ANCHORING MASONRY TO STRUCTURAL STEEL AND CONCRETE

A. Anchor masonry to structural steel and concrete, where masonry abuts or faces structural steel or concrete, to comply with the following:

1. Provide an open space not less than 1/2 inch wide between masonry and structural steel or concrete unless otherwise indicated. Keep open space free of mortar and other rigid materials.
2. Anchor masonry with anchors embedded in masonry joints and attached to structure.
3. Space anchors as indicated, but not more than 24 inches o.c. vertically and 36 inches o.c. horizontally

4. LINTELS

- A. Provide lintels where shown and where openings of more than 12 inches for brick-size units and 24 inches for block-size units are shown without structural steel or other supporting lintels
- B. Provide minimum bearing of 8 inches at each jamb unless otherwise indicated.

5. MASONRY-CELL FILL INSTALLATION

- A. Pour insulation materials into cavities to fill void spaces. Maintain inspection ports to show presence of fill at extremities of each pour area. Close the ports after filling has been confirmed. Limit the fall of fill to one story high, but not more than 20 ft..

- B. Install molded-polystyrene insulation units into masonry unit cells before laying units

6. MASONRY-CELL FILL INSTALLATION

- A. Pour insulation materials into cavities to fill void spaces. Maintain inspection ports to show presence of fill at extremities of each pour area. Close the ports after filling has been confirmed. Limit the fall of fill to one story high, but not more than 20 ft..
- B. Install molded-polystyrene insulation units into masonry unit cells before laying units.

7. REPAIRING, POINTING, AND CLEANING

- A. Remove and replace masonry units that are loose, chipped, broken, stained, or otherwise damaged or that do not match adjoining units. Install new units to match adjoining units; install in fresh mortar, pointed to eliminate evidence of replacement
- B. Pointing: During the tooling of joints, enlarge voids and holes, except weep holes, and completely fill with mortar. Point up joints, including corners, openings, and adjacent construction, to provide a neat, uniform appearance. Prepare joints for sealant application, where indicated.
- C. Final Cleaning: After mortar is thoroughly set and cured, clean exposed masonry as follows:
 - 1. Remove large mortar particles by hand with wooden paddles and nonmetallic scrape hoes or chisels.
 - 2. Test cleaning methods on sample wall panel; leave one-half of panel uncleaned for comparison purposes. Obtain Architect's approval of sample cleaning before proceeding with cleaning of masonry.
 - 3. Protect adjacent stone and non-masonry surfaces from contact with cleaner by covering them with liquid strippable masking agent or polyethylene film and waterproof masking tape.
 - 4. Wet wall surfaces with water before applying cleaners; remove cleaners promptly by rinsing surfaces thoroughly with clear water.
 - 5. Clean concrete masonry by applicable cleaning methods indicated in NCMA TEK 8-4A

8. FIELD QUALITY CONTROL

- B. Testing and Inspecting: Owner will engage special inspectors to perform tests and inspections and prepare reports. Allow inspectors access to scaffolding and work areas as needed to perform tests and inspections. Retesting of materials that fail to comply with specified requirements is done at Contractor's expense.
- C. Inspections: Special inspections in accordance with Level **[B]** **[C]** in TMS 402/ACI 530/ASCE 5.
- D. Testing Prior to Construction: One set of tests.
- E. Testing Frequency: One set of tests for each 5000 sq. ft. of wall area or portion thereof.
- F. Grout Test (Compressive Strength): For each mix provided, in accordance with ASTM C1019

042200

SECTION 044200 - EXTERIOR STONE CLADDING

PART 1 - GENERAL

1.1 SUMMARY

A. Section Includes:

1. Stone panels set with individual anchors.
2. Stone trim units, including sills.

B. Related Requirements:

1. Section 054000 "Cold-Formed Metal Framing" for steel stud frames supporting stone cladding.
2. Section 079200 "Joint Sealants" for sealing joints in stone cladding system with elastomeric sealants.
3. Section 084413 "Glazed Aluminum Curtain Walls" for installing stone panels in aluminum curtain-wall systems.

1.2 ACTION SUBMITTALS

A. Product Data: For each variety of stone, stone accessory, and manufactured product.

B. Shop Drawings: Show fabrication and installation details for stone cladding assembly, including dimensions and profiles of stone units.

1. Show locations and details of joints both within stone cladding assembly and between stone cladding assembly and other construction.
2. Include details of mortar joints sealant joints and mortar joints pointed with sealant.
3. Show locations and details of anchors and backup structure.
4. Show direction of veining, grain, or other directional pattern.
5. Include large-scale shaded elevations and details of decorative surfaces and inscriptions.

C. Samples for Initial Selection: For joint materials involving color selection.

D. Stone Samples for Verification: Sets for each variety, color, and finish of stone required; not less than **12 inches** square.

1. Sets consist of at least two Samples, exhibiting extremes of the full range of color and other visual characteristics expected and will establish the standard by which stone will be judged.

E. Colored Pointing Mortar Samples for Verification: For each color required. Make Samples using same sand and mortar ingredients to be used on Project.

- F. Sealant Samples for Verification: For each type and color of joint sealant required.

1.3 INFORMATIONAL SUBMITTALS

A. Material Test Reports:

1. Stone Test Reports: For stone variety proposed for use on Project, by a qualified testing agency, indicating compliance with required physical properties, other than abrasion resistance, according to referenced ASTM standards. Base reports on testing done within previous five years.
2. For metal components, by a qualified testing agency, indicating chemical and physical properties of metal.
3. Sealant Compatibility and Adhesion Test Report: From sealant manufacturer complying with requirements in Section 079200 "Joint Sealants" and indicating that sealants will not stain or damage stone. Include interpretation of test results and recommendations for primers and substrate preparation needed for adhesion.

1.4 QUALITY ASSURANCE

- A. Fabricator Qualifications: Shop that employs skilled workers who custom fabricate stone cladding assemblies similar to that required for this Project and whose products have a record of successful in-service performance.
- B. Installer Qualifications: A firm or individual experienced in installing stone cladding assemblies similar in material, design, and extent to that indicated for this Project, whose work has a record of successful in-service performance.
- C. Testing Agency Qualifications: Qualified according to ASTM E329 for testing indicated.

1.5 FIELD CONDITIONS

A. Protect stone cladding during erection by doing the following:

1. Cover tops of stone cladding installation with nonstaining, waterproof sheeting at end of each day's work. Cover partially completed structures when work is not in progress. Extend cover a minimum of **24 inches** down both sides and hold securely in place.
2. Prevent staining of stone from mortar, grout, sealants, and other sources. Immediately remove such materials without damaging stone.
3. Protect base of walls from rain-splashed mud and mortar splatter by coverings spread on ground and over wall surface.
4. Protect sills, ledges, and projections from mortar and sealant droppings.

- B. Cold-Weather Requirements: Do not use frozen materials or materials mixed or coated with ice or frost. Remove and replace stone cladding damaged by frost or freezing conditions. Comply with cold-weather construction and protection requirements for masonry contained in TMS 602/ACI 530.1/ASCE 6.

- C. Hot-Weather Requirements: Comply with hot-weather construction and protection requirements for masonry contained in TMS 602/ACI 530.1/ASCE 6.
- D. Environmental Limitations for Sealants: Do not install sealants when ambient and substrate temperatures are outside limits permitted by sealant manufacturer or below **40 deg F** or when joint substrates are wet.

PART 2 - PRODUCTS

2.1 PERFORMANCE REQUIREMENTS

- A. General: Design stone anchors and anchoring systems according to ASTM C1242.
- B. Thermal Movements: Allow for thermal movements from ambient and surface temperature changes.
 - 1. Temperature Change: **120 deg F**, ambient; **180 deg F**, material surfaces.
- C. Safety Factors for Stone: Design stone cladding assembly to withstand loads indicated without exceeding stone's allowable working stress determined by dividing stone's average ultimate strength, as established by testing, by the following safety factors:
 - 1. Safety Factor for Oolitic Limestone: 8.
 - 2. Safety Factor for Dolomitic Limestone: 6.
- D. Design stone anchors and backup structure to withstand loads indicated without exceeding allowable working stresses established by the following:
 - 1. For Structural Steel: AISC 360.
 - 2. For Cold-Formed Steel: AISI's "North American Specification and Commentary for the Design of Cold-Formed Steel Structural Members."
 - 3. For Cold-Formed Stainless Steel: ASCE/SEI 8, "Specification for the Design of Cold-Formed Stainless Steel Structural Members."
 - 4. For Aluminum: AA ADM-1, "The Aluminum Design Manual."
 - 5. For Postinstalled Fasteners in Masonry: One-sixth of tested capacity when installed in masonry units indicated.
- E. Corrosion and Staining Control: Prevent galvanic and other forms of corrosion as well as staining by isolating metals and other materials from direct contact with incompatible materials. Materials do not stain exposed surfaces of stone and joint materials.
- F. Portland Cement: ASTM C150/C150M, Type I or Type II, except Type III may be used for cold-weather construction, natural color or white as required to produce mortar color indicated.
 - 1. Low-Alkali Cement: Portland cement for use with limestone contains no more than 0.60 percent total alkali when tested according to ASTM C114.
- G. Hydrated Lime: ASTM C207.

- H. Portland Cement-Lime Mix: Packaged blend of portland cement and hydrated lime.
- I. Aggregate: ASTM C144; except for [joints narrower than **1/4 inch**][and][pointing mortar], 100 percent pass **No. 16** sieve.
 - 1. White Aggregates: Natural white sand or ground white stone.
 - 2. Colored Aggregates: Natural-colored sand or ground marble, granite, or other durable stone; of color necessary to produce required mortar color.
- J. Water: Potable.

2.2 STONE ACCESSORIES

- A. Setting Buttons: Resilient plastic buttons, nonstaining to stone, sized to suit joint thicknesses and bed depths of stone units without intruding into required depths of pointing materials.
- B. Concealed Sheet Metal Flashing: Fabricated from stainless steel in thicknesses indicated, but not less than **0.0156 inch** thick, and complying with Section 076200 "Sheet Metal Flashing and Trim."
- C. Cementitious Dampproofing for Limestone: Cementitious formulation recommended by ILI and nonstaining to stone; compatible with joint sealants and noncorrosive to anchors and attachments.
- D. Cellular Plastic Weep Hole/Vents: One-piece, flexible extrusion made from UV-resistant polypropylene copolymer, of length required to extend from exterior face of stone to cavity behind, in color selected from manufacturer's standard.
- E. Mesh Weep/Vent: Free-draining mesh; made from polyethylene strands, of length required to extend from exterior face of stone to cavity behind, in color selected from manufacturer's standard.

2.3 FABRICATION OF STONE

- A. General: Fabricate stone units in sizes and shapes required to comply with requirements indicated.
 - 1. For limestone, comply with recommendations in ILI's "Indiana Limestone Handbook."
- B. Cut and drill sinkages and holes in stone for anchors, fasteners, supports, and lifting devices as indicated or needed to set stone securely in place.
- C. Finish exposed faces and edges of stone to comply with requirements indicated for finish and to match approved samples.
- D. Cut stone to produce uniform joints **1/2 inch** wide and in locations indicated.

- E. Contiguous Work: Provide chases, reveals, reglets, openings, and similar features as required to accommodate contiguous work.
- F. Fabricate molded work, including washes and drips, to produce stone shapes with a uniform profile throughout entire unit length, with precisely formed arris slightly eased to prevent snipping, and with matching profile at joints between units.
- G. Clean backs of stone to remove rust stains, iron particles, and stone dust.
- H. Inspect finished stone units at fabrication plant for compliance with requirements for appearance, material, and fabrication. Replace defective units.
 - 1. Grade and mark stone for overall uniform appearance when assembled in place. Natural variations in appearance are acceptable if installed stone units match range of colors and other appearance characteristics represented in approved samples and mockups.
- I. Surface Preparation: After fabricating steel items, prepare surfaces to comply with SSPC-SP 6/NACE No. 3, "Commercial Blast Cleaning."
- J. Apply one coat of fast-curing, lead- and chromate-free, universal modified-alkyd primer complying with MPI#76. **[After primer has dried, apply one coat of exterior alkyd enamel complying with MPI#96 of a different color than primer.]**
- K. Apply two-coat, high-performance coating system consisting of epoxy zinc-rich primer, complying with MPI#20 and topcoat of high-build epoxy coating, complying with MPI#108.

2.4 SOURCE QUALITY CONTROL

PART 3 - EXECUTION

3.1 INSTALLATION OF STONE CLADDING, GENERAL

- A. Before setting stone, clean surfaces that are dirty or stained by removing soil, stains, and foreign materials. Clean stone by thoroughly scrubbing with fiber brushes and then drenching with clear water. Use only mild cleaning compounds that contain no caustic or harsh materials or abrasives.
- B. Execute stone cladding installation by skilled mechanics and employ skilled stone fitters at Project site to do necessary field cutting as stone is set.
 - 1. Use power saws with diamond blades to cut stone. Produce lines cut straight and true, with edges eased slightly to prevent snipping.
- C. Contiguous Work: Provide reveals, reglets, and openings as required to accommodate contiguous work.

- D. Provide expansion, control, and pressure-relieving joints of widths and at locations indicated.
 - 1. Sealing expansion and other joints is specified in Section 079200 "Joint Sealants."
 - 2. Keep expansion joints free of mortar and other rigid materials.
- E. Install concealed flashing at continuous shelf angles, lintels, ledges, and similar obstructions to downward flow of water, to divert water to building exterior. Extend flashing **6 inches** at ends and turn up not less than **2 inches** to form end dams.

3.2 INSTALLATION OF STONE CLADDING WITH MORTAR

- A. Set stone in full bed of mortar with head joints filled unless otherwise indicated.
 - 1. Use setting buttons of adequate size, in sufficient quantity, and of thickness required to maintain uniform joint width and to prevent mortar from extruding. Hold buttons back from face of stone a distance at least equal to width of joint, but not less than depth of pointing materials.
 - 2. Do not set heavy units or projecting courses until mortar in courses below has hardened enough to resist being squeezed out of joint.
 - 3. Support and brace projecting stones until wall above is in place and mortar has set.
 - 4. Provide compressible filler in ends of dowel holes and bottoms of kerfs to prevent end bearing of dowels and anchor tabs on stone. Fill remainder of anchor holes and kerfs with mortar.
- B. Embed ends of sills in mortar; leave remainder of joint open until final pointing.
- C. Rake out joints for pointing with mortar to depths of not less than **1/2 inch**. Rake joints to uniform depths with square bottoms and clean sides.
- D. Prepare stone-joint surfaces for pointing with mortar by removing dust and mortar particles. Where setting mortar was removed to depths greater than surrounding areas, apply first layer of pointing mortar in layers not more than **3/8 inch** until a uniform depth is formed.
- E. Point stone joints by placing pointing mortar in layers not more than **3/8 inch**. Compact each layer thoroughly and allow to become thumbprint hard before applying next layer.
- F. Tool joints with a round jointer having a diameter **1/8 inch** larger than width of joint, when pointing mortar is thumbprint hard.
- G. Rake out mortar from sealant-pointed joints to depths required for sealant and sealant backing, but not less than **1/2 inch**. Rake joints to uniform depths with square bottoms and clean sides.
- H. Set the following stone cladding with unfilled head joints for installing joint sealants:
 - 1. Cornices.

2. Copings.
3. Sills.
4. Belt and other projecting courses.

3.3 INSTALLATION OF JOINT-SEALANTS

- A. Prepare joints and apply sealants of type and at locations indicated to comply with applicable requirements in Section 079200 "Joint Sealants."

3.4 INSTALLATION TOLERANCES

- A. Variation from Level: For lintels, sills, water tables, parapets, horizontal bands, horizontal grooves, and other conspicuous lines, do not exceed **1/8 inch in 10 feet, 1/4 inch in 20 feet, or 3/8 inch** maximum.
- B. Variation in Joint Width: Do not vary from average joint width more than plus or minus **1/8 inch** or a quarter of nominal joint width, whichever is less. For joints within **60 inches** of each other, do not vary more than **1/8 inch** or a quarter of nominal joint width, whichever is less from one to the other.
- C. Variation in Plane between Adjacent Stone Units (Lipping): Do not exceed **1/16-inch** difference between planes of adjacent units.

END OF SECTION 044200

SECTION 051200 - STRUCTURAL STEEL FRAMING

1. GENERAL

1. RELATED DOCUMENTS

2. Drawings and general provisions of the Contract, including General and Supplementary Conditions and Division 01 Specification Sections, apply to this Section. If differing requirements are identified elsewhere (in these specifications or on drawings or separate instructions), the more stringent requirement shall be met.

3. SUMMARY

A. Section Includes:

1. Structural steel.
2. Shear stud connectors, shop welded.
3. Shrinkage-resistant grout.

B. Related Requirements:

1. Section 051213 "Architecturally Exposed Structural Steel Framing" for additional requirements for architecturally exposed structural steel.
2. Section 053100 "Steel Decking" for field installation of shear stud connectors through deck.
3. Section "078123 - Intumescent Fireproofing".

4. DEFINITIONS

- A. Structural Steel: Elements of the structural frame indicated on Drawings and as described in ANSI/AISC 303.

5. PREINSTALLATION MEETINGS

- A. Preinstallation Conference: Conduct conference at Project site.

6. ACTION SUBMITTALS

A. Product Data:

1. Structural-steel materials.
2. High-strength, bolt-nut-washer assemblies.
3. Shear stud connectors.
4. Anchor rods.
5. Threaded rods.

6. Shop primer.
7. Galvanized-steel primer.
8. Etching cleaner.
9. Galvanized repair paint.
10. Shrinkage-resistant grout.

B. Shop Drawings: Show fabrication of structural-steel components.

7. INFORMATIONAL SUBMITTALS

- A. Welding certificates submitted to special inspector for review.
- B. Field quality-control and special inspection reports.
- C. Certified letter stating that they have done a survey of existing conditions.

8. QUALITY ASSURANCE

- A. Fabricator Qualifications: A qualified fabricator that participates in the AISC Quality Certification Program and is designated an AISC-Certified Plant, Category BU is accredited by the IAS Fabricator Inspection Program for Structural Steel (Acceptance Criteria 172), or a fabricator that can provide documentation that their process meets or exceeds AISC standards.
- B. Installer Qualifications: A qualified installer who participates in the AISC Quality Certification Program and is designated an AISC-Certified Erector, Category CSE, or that can provide documentation through references that they have done this type of work for more than 5 years.
- C. Welding Qualifications: Qualify procedures and personnel in accordance with AWS D1.1/D1.1M.

2.PRODUCTS

1. PERFORMANCE REQUIREMENTS

- A. Comply with applicable provisions of the following specifications and documents, refer to the local building code to determine the applicable version:
 1. ANSI/AISC 303.
 2. ANSI/AISC 360.
 3. RCSC's "Specification for Structural Joints Using High-Strength Bolts."
- B. Simple shear connections: Provide details of connections required by the Contract Documents to be selected or completed by structural-steel fabricator to withstand loads indicated and comply with other information and restrictions indicated.
 1. Select and complete connections using schematic details indicated and AISC 360.
 2. Where beam end reactions are not shown provide connections capable of resisting one half the "Maximum Total Uniform Load" table value for a given beam size and span provided in AISC's Steel Construction Manual.
 3. Use Allowable Stress Design; data are given at service-load level.

- C. Moment and bracing connections: Provide connections required by the Contract Documents and AISC 360.
 - 1. All bolts to be considered slip critical, except in end plate connections where pre-tensioned bolts shall be used.
 - 2. For all complete joint penetration welds (CJP) select the appropriate type of weld per AWS to complete the connection.
 - 3. Provide welded shim plates as needed for all flange plate connections.
 - 4.
- D. Moment Connections: Type FR, fully restrained.
- E. Construction: Combined system of moment frame, braced frame, and shear walls.

2. STRUCTURAL-STEEL MATERIALS

- A. W-Shapes: ASTM A992/A992M or ASTM A572/A572M, Grade 50.
- B. Channels, Angles, M, S-Shapes: ASTM A36/A36M.
- C. Plate and Bar: ASTM A36/A36M.
- D. Cold-Formed Hollow Structural Sections and steel pipe: ASTM A500/A500M, Grade B or ASTM A500/A500M, Grade C structural tubing.
- E. Corrosion-Resisting (Weathering), Cold-Formed Hollow Structural Sections: ASTM A847/A847M structural tubing.
- F. Steel Castings: ASTM A216/A216M, Grade WCB, with supplementary requirement S11.
- G. Steel Forgings: ASTM A668/A668M.
- H. Welding Electrodes: Comply with AWS requirements.

3. BOLTS AND CONNECTORS

- A. High-Strength A325 Bolts, Nuts, and Washers: ASTM F3125/F3125M, Grade A325, Type 1, heavy-hex steel structural bolts; ASTM A563, Grade DH, heavy-hex carbon-steel nuts; and ASTM F436/F436M, Type 1, hardened carbon-steel washers; all with plain finish.
 - 1. Direct-Tension Indicators: ASTM F959/F959M, Type 325-1, compressible-washer type with plain finish.
 - 2. Direct-Tension Indicators: Squirter DTI's by Applied Bolting Technology.
 - 3. Twist-Off Type Tension Control Bolts: ASTM F1852
- B. High-Strength A490 Bolts, Nuts, and Washers: ASTM F3125/F3125M, Grade A490, Type 1, heavy-hex steel structural bolts or Grade F2280 tension-control, bolt-nut-washer assemblies with splined ends; ASTM A563, Grade DH, heavy-hex carbon-steel nuts; and ASTM F436/F436M, Type 1, hardened carbon-steel washers; all with plain finish.
 - 1. Direct-Tension Indicators: ASTM F959/F959M, Type 490-1, compressible-washer type with plain finish.

- C. Zinc-Coated High-Strength A325 Bolts, Nuts, and Washers: ASTM F3125/F3125M, Grade A325, Type 1, heavy-hex steel structural bolts; ASTM A563, Grade DH, heavy-hex carbon-steel nuts; and ASTM F436/F436M, Type 1, hardened carbon-steel washers.
 - 1. Finish: Hot-dip zinc coating.
 - 2. Direct-Tension Indicators: ASTM F959/F959M, Type 325-1, compressible-washer type with mechanically deposited zinc coating finish.
 - D. Tension-Control, High-Strength Bolt-Nut-Washer Assemblies: ASTM F3125/F3125M, Grade F1852, Type 1, heavy-hex or round head assemblies, consisting of steel structural bolts with splined ends; ASTM A563, Grade DH, heavy-hex carbon-steel nuts; and ASTM F436/F436M, Type 1, hardened carbon-steel washers.
 - 1. Finish: Plain UNO.
 - E. Shear Stud Connectors: ASTM A108, AISI C-1015 through C-1020, headed-stud type, cold-finished carbon steel; AWS D1.1/D1.1M, Type B
4. RODS
- A. Unheaded Anchor Rods: ASTM F1554, Grade 36 or ASTM F1554, Grade 55 (w/ S1 supplement).
 - 1. Configuration: Straight.
 - 2. Finish: Plain or Hot-dip zinc coating, ASTM A153/A153M, Class C.
 - B. Headed Anchor Rods: ASTM F1554, Grade 36 or ASTM F1554, Grade 55 (w/ S1 supplement), straight.
 - 1. Finish: Plain or Hot-dip zinc coating, ASTM A153/A153M, Class C.
 - C. Threaded Rods: ASTM A36/A36M.
 - 1. Finish: Plain or Hot-dip zinc coating, ASTM A153/A153M, Class C.
5. PRIMER
- A. Steel Primer:
 - 1. Comply with Section 099113 "Exterior Painting" and Section 099123 "Interior Painting".
 - 2. SSPC-Paint 23, latex primer.
 - 3. Fabricator's standard lead- and chromate-free, nonasphaltic, rust-inhibiting primer complying with MPI#79 and compatible with topcoat.
 - B. Galvanized-Steel Primer: MPI#26.
 - 1. Etching Cleaner: MPI#25, for galvanized steel.
 - 2. Galvanizing Repair Paint: MPI#18, MPI#19, SSPC-Paint 20, or ASTM A780/A780M.

6. SHRINKAGE-RESISTANT GROUT

- A. Nonmetallic, Shrinkage-Resistant Grout: ASTM C1107/C1107M, factory-packaged, nonmetallic aggregate grout, noncorrosive and nonstaining, mixed with water to consistency suitable for application and a 30-minute working time.

7. FABRICATION

- A. Structural Steel: Fabricate and assemble in shop to greatest extent possible. Fabricate in accordance with ANSI/AISC 303 and to ANSI/AISC 360.
- B. Shear Stud Connectors: Prepare steel surfaces as recommended by manufacturer of shear connectors. Weld using automatic end welding of headed-stud shear connectors in accordance with AWS D1.1/D1.1M and manufacturer's written instructions.

8. SHOP CONNECTIONS

- A. High-Strength Bolts: Shop install high-strength bolts in accordance with RCSC's "Specification for Structural Joints Using High-Strength Bolts" for type of bolt and type of joint specified.
- B. Weld Connections: Comply with AWS D1.1/D1.1M for tolerances, appearances, welding procedure specifications, weld quality, and methods used in correcting welding work.

9. GALVANIZING

- A. Hot-Dip Galvanized Finish: Apply zinc coating by the hot-dip process to structural steel in accordance with ASTM A123/A123M.
 - 1. Fill vent and drain holes that are exposed in the finished Work unless they function as weep holes, by plugging with zinc solder and filing off smooth.

10. SHOP PRIMING

- A. Shop prime steel surfaces, except the following:
 - 1. Surfaces embedded in concrete or mortar. Extend priming of partially embedded members to a depth of 2 inches.
 - 2. Surfaces to be field welded.
 - 3. Surfaces of high-strength bolted, slip-critical connections.
 - 4. Surfaces to receive sprayed fire-resistive materials (applied fireproofing).
 - 5. Surfaces to receive intumescent paint if/when required by manufacturer. Coordinate with Section "078123 - Intumescent Fireproofing".
 - 6. Galvanized surfaces unless indicated to be painted.
 - 7. Surfaces enclosed in interior construction.
- B. Surface Preparation of Steel: Clean surfaces to be painted. Remove loose rust and mill scale and spatter, slag, or flux deposits. Prepare surfaces in accordance with the following specifications and standards:
 - 1. SSPC-SP 2.

2. SSPC-SP 3.
 3. SSPC-SP 7 (WAB)/NACE WAB-4.
 4. SSPC-SP 6 (WAB)/NACE WAB-3.
- C. Surface Preparation of Galvanized Steel: Prepare galvanized-steel surfaces for shop priming by thoroughly cleaning steel of grease, dirt, oil, flux, and other foreign matter, and treating with etching cleaner or in accordance with SSPC-SP 16.
- D. Priming: Immediately after surface preparation, apply primer in accordance with manufacturer's written instructions and at rate recommended by SSPC to provide a minimum dry film thickness of 1.5 mils. Use priming methods that result in full coverage of joints, corners, edges, and exposed surfaces.
11. SOURCE QUALITY CONTROL
- A. If one of the two conditions below is followed then source quality control need not be required provided approved by building official:
1. The fabricator is AISC certified and provides documentation they are approved to perform such work without special inspection, and at the completion of fabrication the approved fabricator shall submit a certificate of compliance to the building official stating that the work was performed in accordance with the approved construction documents.
 2. The fabrication process does not require any welding, thermal cutting, heating operations of any kind. In such cases the fabricator shall submit a detailed procedure for material control that demonstrates the fabricator's ability to maintain suitable records and procedures such that, at any time during the fabrication process, the material specification, grade and mill test reports for the main stress-carrying elements are capable of being determined.
- B. Testing Agency: Engage a qualified testing agency to perform shop tests and inspections.
1. Allow testing agency access to places where structural-steel work is being fabricated or produced to perform tests and inspections.
 2. Bolted Connections: Inspect and test shop-bolted connections in accordance with RCSC's "Specification for Structural Joints Using High-Strength Bolts."
 3. Welded Connections: Visually inspect shop-welded connections in accordance with AWS D1.1/D1.1M and the following inspection procedures, at testing agency's option:
 - a. Liquid Penetrant Inspection: ASTM E165/E165M.
 - b. Magnetic Particle Inspection: ASTM E709; performed on root pass and on finished weld. Cracks or zones of incomplete fusion or penetration are not accepted.
 - c. Ultrasonic Inspection: ASTM E164.
 - d. Radiographic Inspection: ASTM E94/E94M.
 4. In addition to visual inspection, test and inspect shop-welded shear stud connectors in accordance with requirements in AWS D1.1/D1.1M.
 5. Prepare test and inspection reports.

3.EXECUTION

1. EXAMINATION

- A. Verify, with certified steel erector present, elevations of concrete- and masonry-bearing surfaces and locations of anchor rods, bearing plates, and other embedments for compliance with requirements.
- B. Proceed with installation only after unsatisfactory conditions have been corrected.

2. ERECTION

- A. Set structural steel accurately in locations and to elevations indicated and in accordance with ANSI/AISC 303 and ANSI/AISC 360.
- B. Baseplates, Bearing Plates, and Leveling Plates: Clean concrete- and masonry-bearing surfaces of bond-reducing materials, and roughen surfaces prior to setting plates. Clean bottom surface of plates.
 - 1. Set plates for structural members on wedges, shims, or setting nuts as required.
 - 2. Weld plate washers to top of baseplate.
 - 3. Snug-tighten UNO anchor rods after supported members have been positioned and plumbed. Do not remove wedges or shims but, if protruding, cut off flush with edge of plate before packing with grout.
 - 4. Promptly pack shrinkage-resistant grout solidly between bearing surfaces and plates, so no voids remain. Neatly finish exposed surfaces; protect grout and allow to cure. Comply with manufacturer's written installation instructions for grouting.
- C. Maintain erection tolerances of structural steel within ANSI/AISC 303.
- D. Do not use thermal cutting during erection unless approved by Architect. Finish thermally cut sections within smoothness limits in AWS D1.1/D1.1M.

3. FIELD CONNECTIONS

- A. High-Strength Bolts snug tightened unless indicated: Shop install high-strength bolts according to RCSC's "Specification for Structural Joints Using ASTM A 325 or A 490 Bolts" for type of bolt and for snug tightened joint.
- B. High-Strength Bolts pretensioned and slip critical: Shop install high-strength bolts according to RCSC's "Specification for Structural Joints Using ASTM A 325 or A 490 Bolts" for type of bolt, type of joint specified, and as follows
 - 1. Prepare surface as required for type of joint specified.
 - 2. Install specification approved bolt or washer type connection.
 - 3. For Direct Tension Indicators tighten connection with all needed washers as indicated in installation instructions.
 - 4. All bolt installation shall be done under the direct supervision of an inspector

- C. Weld Connections: Comply with AWS D1.1/D1.1M and AWS D1.8/D1.8M for tolerances, appearances, welding procedure specifications, weld quality, and methods used in correcting welding work.
 - 1. Comply with ANSI/AISC 303 and ANSI/AISC 360 for bearing, alignment, adequacy of temporary connections, and removal of paint on surfaces adjacent to field welds.
 - 2. Remove backing bars or runoff tabs where indicated, back gouge, and grind steel smooth.
 - 3. Assemble and weld built-up sections by methods that maintain true alignment of axes without exceeding tolerances in ANSI/AISC 303 for mill material.
 - 4. Shear Stud Connectors: Prepare steel surfaces as recommended by manufacturer of shear connectors. Weld using end welding of headed-stud shear connectors in accordance with AWS D1.1/D1.1M and manufacturer's written instructions

- 4. FIELD QUALITY CONTROL
 - A. Special Inspections: Owner will engage a special inspector to perform the following special inspections:
 - 1. Verify structural-steel materials and inspect steel frame joint details.
 - 2. Verify weld materials and inspect welds.
 - 3. Verify connection materials and inspect high-strength bolted connections.

 - B. Testing Agency: Owner will engage a qualified testing agency to perform tests and inspections.
 - 1. Bolted Connections: Inspect and test bolted connections in accordance with RCSC's "Specification for Structural Joints Using High-Strength Bolts."
 - 2. High-Strength Bolts pretensioned and slip critical: Shop install high-strength bolts according to RCSC's "Specification for Structural Joints Using ASTM A 325 or A 490 Bolts" for type of bolt, type of joint specified, and as follows
 - a. Prepare surface as required for type of joint specified.
 - b. Install specification approved bolt or washer type connection.
 - c. For Direct Tension Indicators tighten connection with all needed washers as indicated in installation instructions.
 - d. All bolt installation shall be done under the direct supervision of an inspector or shop certified quality control individual.
 - 3. Welded Connections: Visually inspect field welds in accordance with AWS D1.1/D1.1M.
 - a. In addition to 100% visual inspection, 10% of all field fillet welds and 100% all complete or partial penetration welds will be tested and inspected according to AWS D1.1/D1.1M and the following inspection procedures, at testing agency's option:
 - 1) Liquid Penetrant Inspection: ASTM E165/E165M.
 - 2) Magnetic Particle Inspection: ASTM E709; performed on root pass and on finished weld. Cracks or zones of incomplete fusion or penetration are not accepted.
 - 3) Ultrasonic Inspection: ASTM E164.
 - 4) Radiographic Inspection: ASTM E94/E94M.

4. Shear Stud Connectors: In addition to visual inspection, test and inspect field-welded shear connectors according to requirements in AWS D1.1/D1.1M for stud welding and as follows:
 - a. Perform bend tests if visual inspections reveal either a less-than-continuous 360-degree flash or welding repairs to any shear connector.
 - 1) Conduct tests according to requirements in AWS D1.1/D1.1M on additional shear connectors if weld fracture occurs on shear connectors already tested..

END OF SECTION 051200

SECTION 053100 - STEEL DECKING

1. GENERAL

1. RELATED DOCUMENTS

- A. Drawings and general provisions of the Contract, including General and Supplementary Conditions and Division 01 Specification Sections, apply to this Section. If differing requirements are identified elsewhere (in these specifications or on drawings or separate instructions), the more stringent requirement shall be met.

2. SUMMARY

A. Section Includes:

- 1. Roof deck.
- 2. Noncomposite form deck.

B. Related Requirements:

- 1. Section 033000 "Cast-in-Place Concrete" for normal-weight and lightweight structural concrete fill over steel deck.
- 2. Section 051200 "Structural Steel Framing" for shop- and field-welded shear connectors.
- 3. Section 055000 "Metal Fabrications" for framing deck openings with miscellaneous steel shapes.

3. ACTION SUBMITTALS

- A. Product Data: For each type of deck, accessory, and product indicated.

B. Shop Drawings:

- 1. Include layout and types of deck panels, anchorage details, reinforcing channels, pans, cut deck openings, special jointing, accessories, and attachments to other construction.

4. INFORMATIONAL SUBMITTALS

- A. Welding certificates for special inspectors use.

- B. Product Test Reports: For tests performed by a qualified testing agency, indicating that each of the following complies with requirements:

- 1. Power-actuated mechanical fasteners.

- C. Evaluation Reports: For steel deck, from ICC-ES.

- 1. Field quality-control reports.

- D. Qualification Statements: For welding personnel and testing agency.

5. QUALITY ASSURANCE

- A. Welding Qualifications: Qualify procedures and personnel in accordance with SDI QA/QC, AWS D1.1/D1.1M, and AWS D1.3/D1.3M.

6. DELIVERY, STORAGE, AND HANDLING

- A. Protect steel deck from corrosion, deformation, and other damage during delivery, storage, and handling.
- B. Store products in accordance with SDI MOC3. Stack steel deck on platforms or pallets and slope to provide drainage. Protect with a waterproof covering and ventilate to avoid condensation.
1. Protect and ventilate acoustical cellular roof deck with factory-installed insulation to maintain insulation free of moisture.

2. PRODUCTS

1. PERFORMANCE REQUIREMENTS

- A. AISI Specifications: Comply with calculated structural characteristics of steel deck in accordance with AISI S100.

2. ROOF DECK

- A. Roof Deck: Fabricate panels, without top-flange stiffening grooves, to comply with "SDI Specifications and Commentary for Steel Roof Deck," in SDI Publication No. 31, and with the following:
1. Galvanized Steel Sheet: ASTM A 653/A 653M, Structural Steel (SS), Grade 33, minimum, G60 zinc coating.
2. Deck Profile: As indicated.
3. Cellular Deck Profile: As indicated, with bottom plate.
4. Profile Depth: As indicated.
5. Design Uncoated-Steel Thickness: As indicated.
6. Design Uncoated-Steel Thicknesses; Deck Unit/Bottom Plate: As indicated
7. Span Condition: Triple span or more uno.
8. Side Laps: As indicated.

3. NONCOMPOSITE FORM DECK

- A. Noncomposite Form Deck: Fabricate ribbed-steel sheet noncomposite form-deck panels to comply with "SDI Specifications and Commentary for Noncomposite Steel Form Deck," in SDI Publication No. 31, with the minimum section properties indicated, and with the following:
1. Galvanized Steel Sheet: ASTM A 653/A 653M, Structural Steel (SS), G60 [G90] zinc coating.

2. Deck yield strength: The yield strength varies between deck profile and gauge. The basis of design is per Vulcraft Catalog
3. Deck Profile: As indicated.
4. Profile Depth: As indicated.
5. Design Uncoated-Steel Thickness: As indicated.
6. Span Condition: As indicated.

4. ACCESSORIES

- A. General: Provide manufacturer's standard accessory materials for deck that comply with requirements indicated.
- B. Mechanical Fasteners: Corrosion-resistant, low-velocity, power-actuated or pneumatically driven carbon-steel fasteners; or self-drilling, self-threading screws.
- C. Side-Lap Fasteners: Corrosion-resistant, hexagonal washer head; self-drilling, carbon-steel screws, No. 10 minimum diameter.
- D. Flexible Closure Strips: Vulcanized, closed-cell, synthetic rubber.
- E. Miscellaneous Sheet Metal Deck Accessories: Steel sheet, minimum yield strength of 33,000 psi, not less than 0.0359-inch design uncoated thickness, of same material and finish as deck; of profile indicated or required for application.
- F. Pour Stops and Girder Fillers: Steel sheet, minimum yield strength of 33,000 psi, of same material and finish as deck, and of thickness and profile recommended by SDI Publication No. 31 for overhang and slab depth.
- G. Column Closures, End Closures, Z-Closures, and Cover Plates: Steel sheet, of same material, finish, and thickness as deck unless otherwise indicated.
- A. Weld Washers: Uncoated steel sheet, shaped to fit deck rib, 0.0598 inch thick, with factory-punched hole of 3/8-inch minimum diameter.
- B. Shear Stud Connectors: ASTM A108, AISI C-1015 through C-1020, headed-stud type, cold-finished carbon steel; AWS D1.1/D1.1M, Type B.
- C. Flat Sump Plates: Single-piece steel sheet, 0.0747 inch thick, of same material and finish as deck. For drains, cut holes in the field.
- D. Recessed Sump Pans: Single-piece steel sheet, 0.0747 inch thick, of same material and finish as deck, with 3-inch-wide flanges. See architectural for profile of recessed pans of 1-1/2-inch minimum depth. For drains, cut holes in the field.
- E. Galvanizing Repair Paint: ASTM A780/A780M with dry film containing a minimum of 94 percent zinc dust by weight.
- F. Repair Paint: Manufacturer's standard rust-inhibitive primer of same color as primer.

3.EXECUTION

1. EXAMINATION

- A. Examine supporting frame and field conditions for compliance with requirements for installation tolerances and other conditions affecting performance of the Work.
- B. Proceed with installation only after unsatisfactory conditions have been corrected.

2. INSTALLATION, GENERAL

- A. Install deck panels and accessories in accordance with SDI C, SDI NC, and SDI RD, as applicable; manufacturer's written instructions; and requirements in this Section.
- B. Install temporary shoring before placing deck panels if required to meet deflection limitations.
- C. Locate deck bundles to prevent overloading of supporting members.
- D. Place deck panels on supporting frame and adjust to final position with ends accurately aligned and bearing on supporting frame before being permanently fastened. Do not stretch or contract side-lap interlocks.
- E. Place deck panels flat and square and fasten to supporting frame without warp or deflection.
- F. Cut and neatly fit deck panels and accessories around openings and other work projecting through or adjacent to deck.
- G. Provide additional reinforcement and closure pieces at openings as required for strength, continuity of deck, and support of other work.
- H. Comply with AWS requirements and procedures for manual shielded metal arc welding, appearance and quality of welds, and methods used for correcting welding work.
- I. Mechanical fasteners may be used in lieu of welding to fasten deck. Locate mechanical fasteners and install in accordance with deck manufacturer's written instructions.

3. INSTALLATION OF ROOF DECK

- A. Fasten roof-deck panels to steel supporting members as indicated on plans:
- B. Side-Lap and Perimeter Edge Fastening: Fasten side laps and perimeter edges of panels between supports, at intervals not exceeding the lesser of one-half of the span or 18 inches, and as follows:
 - 1. Mechanically fasten with self-drilling, No. 10 diameter or larger, carbon-steel screws.
 - 2. Fasten with a minimum of 1-1/2-inch-long welds.
 - 3. For specific information on spacing and attachment see drawings.
- C. End Bearing: Install deck ends over supporting frame with a minimum end bearing of 1-1/2 inches, with end joints as follows:

1. End Joints: Lapped 2 inches minimum.
 - D. Roof Sump Pans and Sump Plates: Install over openings provided in roof deck and mechanically fasten flanges to top of deck. Space mechanical fasteners not more than 12 inches apart with at least one fastener at each corner.
 1. Install reinforcing channels or zees in ribs to span between supports and mechanically fasten.
 - E. Miscellaneous Roof-Deck Accessories: Install ridge and valley plates, finish strips, end closures, and reinforcing channels according to deck manufacturer's written instructions. mechanically fasten to substrate to provide a complete deck installation.
 1. Attach cover plates at changes in direction of roof-deck panels unless otherwise indicated.
 - F. Flexible Closure Strips: Install flexible closure strips over partitions, walls, and where indicated. Install with adhesive according to manufacturer's written instructions to ensure complete closure.
4. INSTALLATION OF FLOOR DECK
- A. Fasten floor-deck panels to steel supporting members by arc spot (puddle) welds of the surface diameter indicated and as follows:
 1. Weld Diameter: as indicated.
 2. Weld Spacing: Weld edge ribs of panels at each support. Space additional welds an average of 12 inches apart, but not more than 18 inches apart.
 3. Weld Spacing: Space and locate welds as indicated.
 4. Weld Washers: Install weld washers at each weld location.
 - B. Side-Lap and Perimeter Edge Fastening: Fasten side laps and perimeter edges of panels between supports, as indicated on plans.
 - C. End Bearing: Install deck ends over supporting frame with a minimum end bearing of 1-1/2 inches, with end joints as follows:
 1. End Joints: Butted.
 - D. Pour Stops and Girder Fillers: Weld steel sheet pour stops and girder fillers to supporting structure according to SDI recommendations unless otherwise indicated.
 - E. Floor-Deck Closures: Weld steel sheet column closures, cell closures, and Z-closures to deck, according to SDI recommendations, to provide tight-fitting closures at open ends of ribs and sides of deck.
5. REPAIR
- A. Galvanizing Repairs: Prepare and repair damaged galvanized coatings on both surfaces of deck with galvanized repair paint in accordance with ASTM A780/A780M and manufacturer's written instructions.

B. Repair Painting:

1. Wire brush and clean rust spots, welds, and abraded areas on both surfaces of prime-painted deck immediately after installation, and apply repair paint.
2. Apply repair paint, of same color as adjacent shop-primed deck, to bottom surfaces of deck exposed to view.
3. Wire brushing, cleaning, and repair painting of rust spots, welds, and abraded areas of both deck surfaces are included in Section 099113 "Exterior Painting" and Section 099123 "Interior Painting."

6. FIELD QUALITY CONTROL

A. Testing Agency: Owner will engage a qualified testing agency to perform tests and inspections.

B. Tests and Inspections:

1. Special inspections and qualification of welding special inspectors for cold-formed steel floor and roof deck in accordance with quality-assurance inspection requirements of SDI QA/QC.
 - a. Field welds will be subject to inspection.
2. Steel decking will be considered defective if it does not pass tests and inspections.
3. Shear Stud Connectors: In addition to visual inspection, test and inspect field-welded shear connectors in accordance with requirements in AWS D1.1/D1.1M for stud welding and as follows:
 - a. Perform bend tests if visual inspections reveal either a less-than-continuous 360-degree flash or welding repairs to any shear connector.
 - b. Conduct tests in accordance with requirements in AWS D1.1/D1.1M on additional shear connectors if weld fracture occurs on shear connectors that are already tested.

C. Prepare test and inspection reports.

END OF SECTION 053100

SECTION 054000 - COLD-FORMED METAL FRAMING

1. GENERAL

1. RELATED DOCUMENTS

2. Drawings and general provisions of the Contract, including General and Supplementary Conditions and Division 01 Specification Sections, apply to this Section. If differing requirements are identified elsewhere (in these specifications or on drawings or separate instructions), the more stringent requirement shall be met.

3. SUMMARY

A. Section Includes:

1. Exterior non-load-bearing wall framing.
2. Interior non-load-bearing wall framing.
3. Ceiling joist framing.
4. Soffit framing.

B. Related Requirements:

1. Section 055000 "Metal Fabrications" for miscellaneous steel shapes, masonry shelf angles, and connections used with cold-formed metal framing.
2. Section 092116.23 "Gypsum Board Shaft Wall Assemblies" for interior non-load-bearing, metal-stud-framed, shaft-wall assemblies, with height limitations.
3. Section 092216 "Non-Structural Metal Framing" for standard, interior non-load-bearing, metal-stud framing, with height limitations and ceiling-suspension assemblies.

4. PREINSTALLATION MEETINGS

- A. Preinstallation Conference: Conduct conference at Project site.

5. ACTION SUBMITTALS

A. Product Data: For the following:

1. Cold-formed steel framing materials.
2. Load-bearing wall framing.
3. Exterior non-load-bearing wall framing.
4. Interior non-load-bearing wall framing.
5. Vertical deflection clips.
6. Single deflection track.
7. Double deflection track.
8. Drift clips.
9. Floor joist framing.
10. Roof-rafter framing.
11. Ceiling joist framing.
12. Soffit framing.

13. Post-installed anchors.
14. Power-actuated anchors.
15. Sill sealer gasket.
16. Sill sealer gasket/termite barrier.

B. Shop Drawings:

1. Include layout, spacings, sizes, thicknesses, and types of cold-formed steel framing; fabrication; and fastening and anchorage details, including mechanical fasteners.
2. Indicate reinforcing channels, opening framing, supplemental framing, strapping, bracing, bridging, splices, accessories, connection details, and attachment to adjoining work.

C. Delegated Design Submittal: For cold-formed steel framing.

6. INFORMATIONAL SUBMITTALS

A. Qualification Data: For testing agency.

B. Welding certificates for special inspectors use only.

C. Product Certificates: For each type of code-compliance certification for studs and tracks.

D. Product Test Reports: For each listed product, for tests performed by a qualified testing agency.

1. Expansion anchors.
2. Power-actuated anchors.
3. Mechanical fasteners.
4. Vertical deflection clips.
5. Horizontal drift deflection clips
6. Miscellaneous structural clips and accessories.

E. Research Reports:

1. For nonstandard cold-formed steel framing post-installed anchors and power-actuated fasteners, from ICC-ES or other qualified testing agency acceptable to authorities having jurisdiction.
2. For sill sealer gasket/termite barrier, showing compliance with ICC-ES AC380.

7. QUALITY ASSURANCE

A. Testing Agency Qualifications: Qualified according to ASTM E329 for testing indicated.

B. Welding Qualifications: Qualify procedures and personnel according to the following:

1. AWS D1.1/D1.1M, "Structural Welding Code - Steel."
2. AWS D1.3/D1.3M, "Structural Welding Code - Sheet Steel."

C. Comply with AISI S230 "Standard for Cold-Formed Steel Framing - Prescriptive Method for One and Two Family Dwellings."

8. DELIVERY, STORAGE, AND HANDLING

- A. Protect and store cold-formed steel framing from corrosion, moisture staining, deformation, and other damage during delivery, storage, and handling as required in AISI S202.

2.PRODUCTS

1. MANUFACTURERS

- A. Available Manufacturers: Subject to compliance with requirements, manufacturers offering products that may be incorporated into the Work, must provide documentation that they have been performing such work for a minimum of 5 years.

2. PERFORMANCE REQUIREMENTS

- A. Structural Performance: Provide cold-formed steel framing capable of withstanding design loads within limits and under conditions indicated.

1. Design framing for loads indicated on drawings and/or for loads imposed on the framing by other trades or materials including all eccentricities.
2. The contractor is responsible for coordinating all loading methods and locations imposed on to the cold form metal framing.
3. The design of the framing shall follow all local, state, and federal building codes.
4. Deflection Limits: Design framing systems to withstand design loads without deflections greater than the following:
 - a. Interior Load-Bearing Wall Framing: Horizontal deflection of 1/360 of the wall height under a horizontal load of 5 lbf/sq. ft..
 - b. Exterior Non-Load-Bearing Framing: Horizontal deflection of 1/600 of the wall height.
 - c. Interior Non-Load-Bearing Framing: Horizontal deflection of 1/360 of the wall height under a horizontal load of 5 lbf/sq. ft..
 - d. Ceiling Joist Framing: Vertical deflection of 1/360 of the span for live loads and 1/240 for total loads of the span.
5. Design framing systems to provide for movement of framing members located outside the insulated building envelope without damage or overstressing, sheathing failure, connection failure, undue strain on fasteners and anchors, or other detrimental effects when subject to a maximum ambient temperature change of 120 deg F.
6. Design framing system to maintain clearances at openings, to allow for construction tolerances, and to accommodate live load deflection of primary building structure as follows:
 - a. Upward and downward movement of 1 inch.
7. Design exterior non-load-bearing wall framing to accommodate horizontal deflection without regard for contribution of sheathing materials.

- B. Cold-Formed Steel Framing Standards: Unless more stringent requirements are indicated, framing shall comply with AISI S100, AISI S200, and the following:

1. Floor and Roof Systems: AISI S210.

2. Wall Studs: AISI S211.
3. Headers: AISI S212.
4. Lateral Design: AISI S213.

3. COLD-FORMED STEEL FRAMING MATERIALS

- A. Framing Members, General: Comply with ASTM C955, AISI S200 and ASTM C955, Section 8, and AISI S240 for conditions indicated.
- B. Steel Sheet: ASTM A1003/A1003M, Structural Grade, Type H, metallic coated, of grade and coating designation as follows:
 1. Grade: As required by structural performance.
 2. Coating: G60, A60, AZ50, or GF30.
- C. Steel Sheet for Vertical Deflection and Drift Clips: ASTM A653/A653M, structural steel, zinc coated, of grade and coating as follows:
 1. Grade: As required by structural performance.
 2. Coating: G60.

4. EXTERIOR NON-LOAD-BEARING WALL FRAMING

- A. Steel Studs: Manufacturer's standard C-shaped steel studs, of web depths indicated, punched, with stiffened flanges, and as follows:
 1. Minimum Base-Metal Thickness:
 - a. Brick backup: As required by design with an 43 mils minimum per ACI 530.
 - b. Metal Panel backup: As required by design with a minimum as required by the metal panel supplier.
 - c. All other materials: As required by design
 2. Flange Width: as required by design.
 3. Section Properties: as required by design.
- B. Steel Track: Manufacturer's standard U-shaped steel track, of web depths indicated, unpunched, with unstiffened flanges, and as follows:
 1. Minimum Base-Metal Thickness: Matching steel studs.
 2. Flange Width: Manufactures standard unless otherwise indicated.
- C. Vertical Deflection Clips: Manufacturer's standard bypass or head clips, capable of accommodating upward and downward vertical displacement of primary structure through positive mechanical attachment to stud web.
- D. Single Deflection Track: Manufacturer's single, deep-leg, U-shaped steel track; unpunched, with unstiffened flanges, of web depth to contain studs while allowing free vertical movement, with flanges designed to support horizontal loads and transfer them to the primary structure, and as follows:
 1. Minimum Base-Metal Thickness: Matching steel studs.
 2. Flange Width: Manufactures standard unless otherwise indicated .

- E. Double Deflection Tracks: Manufacturer's double, deep-leg, U-shaped steel tracks, consisting of nested inner and outer tracks; unpunched, with unstiffened flanges.
 - 1. Outer Track: Of web depth to allow free vertical movement of inner track, with flanges designed to support horizontal loads and transfer them to the primary structure, and as follows:
 - a. Minimum Base-Metal Thickness: Matching steel studs.
 - b. Flange Width: 1 inch plus the design gap for one-story structures, and 1 inch plus twice the design gap for other applications.
 - 2. Inner Track: Of web depth indicated, and as follows:
 - a. Minimum Base-Metal Thickness: Matching steel studs.
 - b. Flange Width: as required by design.
 - F. Drift Clips: Manufacturer's standard bypass or head clips, capable of isolating wall stud from upward and downward vertical displacement and lateral drift of primary structure through positive mechanical attachment to stud web and structure.
5. INTERIOR NON-LOAD-BEARING WALL FRAMING
- A. Steel Studs: Manufacturer's standard C-shaped steel studs, of web depths indicated, punched, with stiffened flanges, and as follows:
 - 1. Minimum Base-Metal Thickness: As required by design
 - 2. Flange Width: as required by design.
 - 3. Section Properties: as required by design.
 - B. Steel Track: Manufacturer's standard U-shaped steel track, of web depths indicated, unpunched, with unstiffened flanges, and as follows:
 - 1. Minimum Base-Metal Thickness: Matching steel studs.
 - 2. Flange Width: Manufactures standard unless otherwise indicated.
 - C. Vertical Deflection Clips: Manufacturer's standard bypass or head clips, capable of accommodating upward and downward vertical displacement of primary structure through positive mechanical attachment to stud web.
 - D. Single Deflection Track: Manufacturer's single, deep-leg, U-shaped steel track; unpunched, with unstiffened flanges, of web depth to contain studs while allowing free vertical movement, with flanges designed to support horizontal loads and transfer them to the primary structure, and as follows:
 - 1. Minimum Base-Metal Thickness: Matching steel studs.
 - 2. Flange Width: Manufactures standard unless otherwise indicated .
 - E. Double Deflection Tracks: Manufacturer's double, deep-leg, U-shaped steel tracks, consisting of nested inner and outer tracks; unpunched, with unstiffened flanges.
 - 1. Outer Track: Of web depth to allow free vertical movement of inner track, with flanges designed to support horizontal loads and transfer them to the primary structure, and as follows:

- a. Minimum Base-Metal Thickness: Matching steel studs.
 - b. Flange Width: 1 inch plus the design gap for one-story structures, and 1 inch plus twice the design gap for other applications.
2. Inner Track: Of web depth indicated, and as follows:
 - a. Minimum Base-Metal Thickness: Matching steel studs.
 - b. Flange Width: as required by design.
- F. Drift Clips: Manufacturer's standard bypass or head clips, capable of isolating wall stud from upward and downward vertical displacement and lateral drift of primary structure through positive mechanical attachment to stud web and structure.
6. CEILING JOIST FRAMING
- A. Steel Ceiling Joists: Manufacturer's standard C-shaped steel sections, of web depths indicated, punched with standard holes, with stiffened flanges, and as follows:
1. Minimum Base-Metal Thickness: as required by design uno.
 2. Flange Width: 1-5/8 inches, minimum.
 3. Section Properties: as required by design.
7. SOFFIT FRAMING
- A. Exterior Soffit Frame: Manufacturer's standard C-shaped steel sections, of web depths indicated, with stiffened flanges, and as follows:
1. Minimum Base-Metal Thickness: as required by design uno.
 2. Flange Width: 1-5/8 inches, minimum.
 3. Section Properties: as required by design>.
8. FRAMING ACCESSORIES
- A. Fabricate steel-framing accessories from ASTM A1003/A1003M, Structural Grade, Type H, metallic coated steel sheet, of same grade and coating designation used for framing members.
- B. Provide accessories of manufacturer's standard thickness and configuration, unless otherwise indicated, as follows:
1. Supplementary framing.
 2. Bracing, bridging, and solid blocking.
 3. Web stiffeners.
 4. Anchor clips.
 5. End clips.
 6. Foundation clips.
 7. Gusset plates.
 8. Stud kickers and knee braces.
 9. Joist hangers and end closures.
 10. Hole-reinforcing plates.
 11. Backer plates.

9. ANCHORS, CLIPS, AND FASTENERS

- A. Steel Shapes and Clips: ASTM A36/A36M, zinc coated by hot-dip process according to ASTM A123/A123M.
- B. Anchor Bolts: ASTM F 1554, Grade 36 weldable, threaded carbon-steel hex-headed bolts, and carbon-steel nuts; and flat, hardened-steel washers; zinc coated by hot-dip process according to ASTM A 153/A 153M, Class C.
- C. Post-Installed Anchors: Fastener systems with bolts of same basic metal as fastened metal, if visible, unless otherwise indicated; with working capacity greater than or equal to the design load, according to an evaluation report acceptable to authorities having jurisdiction, based on ICC-ES AC01, ICC-ES AC193, ICC-ES AC58, or ICC-ES AC308 as appropriate for the substrate.
 - 1. Uses: Securing cold-formed steel framing to structure.
 - 2. Type: Torque-controlled expansion anchor, Mechanical anchor, Torque-controlled adhesive anchor or adhesive anchor.
 - 3. Material for Interior Locations: Carbon-steel components zinc plated to comply with ASTM B633 or ASTM F1941, Class Fe/Zn 5, unless otherwise indicated.
 - 4. Material for Exterior or Interior Locations and Where Stainless Steel Is Indicated: Alloy Group 1 stainless-steel bolts, ASTM F593, and nuts, ASTM F594.
- D. Power-Actuated Anchors: Fastener systems with working capacity greater than or equal to the design load, according to an evaluation report acceptable to authorities having jurisdiction, based on ICC-ES AC70.
- E. Mechanical Fasteners: ASTM C1513, corrosion-resistant-coated, self-drilling, self-tapping, steel drill screws.
 - 1. Head Type: Low-profile head beneath sheathing; manufacturer's standard elsewhere.
- F. Welding Electrodes: Comply with AWS standards.

10. MISCELLANEOUS MATERIALS

- A. Galvanizing Repair Paint: ASTM A780/A780M, MIL-P-21035B, or] SSPC-Paint 20.
- B. Cement Grout: Portland cement, ASTM C150/C150M, Type I; and clean, natural sand, ASTM C404. Mix at ratio of 1 part cement to 2-1/2 parts sand, by volume, with minimum water required for placement and hydration.
- C. Nonmetallic, Nonshrink Grout: Factory-packaged, nonmetallic, noncorrosive, nonstaining grout, complying with ASTM C1107/C1107M, and with a fluid consistency and 30-minute working time.
- D. Shims: Load-bearing, high-density, multimonomer, nonleaching plastic; or cold-formed steel of same grade and metallic coating as framing members supported by shims.
- E. Sill Sealer Gasket: Closed-cell neoprene foam, 1/4 inch thick, selected from manufacturer's standard widths to match width of bottom track or rim track members as required.

- F. Sill Sealer Gasket/Termite Barrier: Minimum 68-mil nominal thickness, self-adhering sheet consisting of 64 mils of rubberized asphalt laminated on one side to a 4-mil-thick, polyethylene-film reinforcement, and with release liner on adhesive side[; formulated for application with primer or surface conditioner that complies with VOC limits of authorities having jurisdiction].
1. <Double click here to find, evaluate, and insert list of manufacturers and products.>
 2. Physical Properties:
 - a. Peel Adhesion: 17.0 lb/in of width when tested in accordance with ASTM D412.
 - b. Low-Temperature Flexibility: Pass at minus 25 deg F when tested in accordance with ASTM D146/D146M.
 - c. Water Vapor Permeance: 0.05 perm maximum when tested in accordance with ASTM E96/E96M, Method B.
 - d. Resistance to Termite Penetration: Comply with ICC-ES AC380.

11. FABRICATION

- A. Fabricate cold-formed steel framing and accessories plumb, square, and true to line, and with connections securely fastened, according to referenced AISI's specifications and standards, manufacturer's written instructions, and requirements in this Section.
1. Fabricate framing assemblies using jigs or templates.
 2. Cut framing members by sawing or shearing; do not torch cut.
 3. Fasten cold-formed steel framing members by welding, screw fastening, clinch fastening, pneumatic pin fastening, or riveting as standard with fabricator. Wire tying of framing members is not permitted.
 - a. Comply with AWS D1.3/D1.3M requirements and procedures for welding, appearance and quality of welds, and methods used in correcting welding work.
 - b. Locate mechanical fasteners and install according to Shop Drawings, with screws penetrating joined members by no fewer than three exposed screw threads.
 4. Fasten other materials to cold-formed steel framing by welding, bolting, pneumatic pin fastening, or screw fastening, according to Shop Drawings.
- B. Reinforce, stiffen, and brace framing assemblies to withstand handling, delivery, and erection stresses. Lift fabricated assemblies by means that prevent damage or permanent distortion.
- C. Tolerances: Fabricate assemblies level, plumb, and true to line to a maximum allowable variation of 1/8 inch in 10 feet and as follows:
1. Spacing: Space individual framing members no more than plus or minus 1/8 inch from plan location. Cumulative error are not to exceed minimum fastening requirements of sheathing or other finishing materials.
 2. Squareness: Fabricate each cold-formed steel framing assembly to a maximum out-of-square tolerance of 1/8 inch.

3.EXECUTION

1. EXAMINATION

- A. Examine substrates, areas, conditions, and abutting structural framing for compliance with requirements for installation tolerances and other conditions affecting performance of the Work.
- B. Proceed with installation only after unsatisfactory conditions have been corrected.

2. PREPARATION

- A. Before sprayed fire-resistive materials are applied, attach continuous angles, supplementary framing, or tracks to structural members indicated to receive sprayed fire-resistive materials.
- B. After applying sprayed fire-resistive materials, remove only as much of these materials as needed to complete installation of cold-formed framing without reducing thickness of fire-resistive materials below that required to obtain fire-resistance ratings indicated. Protect remaining fire-resistive materials from damage.
- C. Install load-bearing shims or grout between the underside of load-bearing wall bottom track and the top of foundation wall or slab at locations with a gap larger than 1/4 inch to ensure a uniform bearing surface on supporting concrete or masonry construction.
- D. Install sill sealer gasket at the underside of wall bottom track or rim track and at the top of foundation wall or slab at stud or joist locations.
- E. Install sill sealer gasket/termite barrier in accordance with manufacturer's written instructions at the underside of wall bottom track or rim track and at the top of foundation wall or slab at stud or joist locations.

3. INSTALLATION, GENERAL

- A. Cold-formed steel framing may be shop or field fabricated for installation, or it may be field assembled.
- B. Install cold-formed steel framing according to AISI S200, AISI S202, and manufacturer's written instructions unless more stringent requirements are indicated.
- C. Install shop- or field-fabricated, cold-formed framing and securely anchor to supporting structure.
 - 1. Screw, bolt, or weld wall panels at horizontal and vertical junctures to produce flush, even, true-to-line joints with maximum variation in plane and true position between fabricated panels not exceeding 1/16 inch.
- D. Install cold-formed steel framing and accessories plumb, square, and true to line, and with connections securely fastened.
 - 1. Cut framing members by sawing or shearing; do not torch cut.
 - 2. Fasten cold-formed steel framing members by welding, screw fastening, clinch fastening, or riveting. Wire tying of framing members is not permitted.

- a. Comply with AWS D1.3/D1.3M requirements and procedures for welding, appearance and quality of welds, and methods used in correcting welding work.
 - b. Locate mechanical fasteners, install according to Shop Drawings, and comply with requirements for spacing, edge distances, and screw penetration.
- E. Install framing members in one-piece lengths unless splice connections are indicated for track or tension members.
- F. Install temporary bracing and supports to secure framing and support loads equal to those for which structure was designed. Maintain braces and supports in place, undisturbed, until entire integrated supporting structure has been completed and permanent connections to framing are secured.
- G. Do not bridge building expansion joints with cold-formed steel framing. Independently frame both sides of joints.
- H. Install insulation, specified in Section 072100 "Thermal Insulation," in framing-assembly members, such as headers, sills, boxed joists, and multiple studs at openings, that are inaccessible on completion of framing work.
- I. Fasten hole-reinforcing plate over web penetrations that exceed size of manufacturer's approved or standard punched openings.
4. INSTALLATION OF EXTERIOR NONLOADBEARING WALL FRAMING
- A. Install continuous tracks sized to match studs. Align tracks accurately and securely anchor to supporting structure.
 - B. Fasten both flanges of studs to top and bottom track unless otherwise indicated. Space studs as follows:
 1. Stud Spacing: As indicated.
 - C. Set studs plumb, except as needed for diagonal bracing or required for non-plumb walls or warped surfaces and similar requirements.
 - D. Isolate non-load-bearing steel framing from building structure to prevent transfer of vertical loads while providing lateral support.
 1. Install single deep-leg deflection tracks and anchor to building structure.
 2. Install double deep-leg deflection tracks and anchor outer track to building structure.
 3. Connect vertical deflection clips to **[bypassing]** **[infill]** studs and anchor to building structure.
 4. Connect drift clips to cold-formed steel framing and anchor to building structure.
 - E. Install horizontal bridging in wall studs, spaced vertically in rows indicated on Shop Drawings but not more than 48 inches apart. Fasten at each stud intersection.
 1. Channel Bridging: Cold-rolled steel channel, welded or mechanically fastened to webs of punched studs.
 2. Strap Bridging: Combination of flat, taut, steel sheet straps of width and thickness indicated and stud-track solid blocking of width and thickness to match studs. Fasten flat straps to stud flanges and secure solid blocking to stud webs or flanges.

3. Bar Bridging: Proprietary bridging bars installed according to manufacturer's written instructions.
 - F. Top Bridging for Single Deflection Track: Install row of horizontal bridging within 12 inches of single deflection track. Install a combination of bridging and stud or stud-track solid blocking of width and thickness matching studs, secured to stud webs or flanges.
 1. Install solid blocking at centers indicated on Shop Drawings.
 - G. Install miscellaneous framing and connections, including stud kickers, web stiffeners, clip angles, continuous angles, anchors, and fasteners, to provide a complete and stable wall-framing system.
5. INSTALLATION OF INTERIOR NON-LOAD-BEARING WALL FRAMING
- A. Install continuous tracks sized to match studs. Align tracks accurately and securely anchor to supporting structure.
 - B. Fasten both flanges of studs to top and bottom track unless otherwise indicated. Space studs as follows:
 1. Stud Spacing: As indicated.
 - C. Set studs plumb, except as needed for diagonal bracing or required for nonplumb walls or warped surfaces and similar requirements.
 - D. Isolate non-load-bearing steel framing from building structure to prevent transfer of vertical loads while providing lateral support.
 1. Install single deep-leg deflection tracks and anchor to building structure.
 2. Install double deep-leg deflection tracks and anchor outer track to building structure.
 3. Connect vertical deflection clips to studs and anchor to building structure.
 4. Connect drift clips to cold-formed steel metal framing and anchor to building structure.
 - E. Install horizontal bridging in wall studs, spaced vertically in rows indicated on Shop Drawings but not more than 48 inches apart. Fasten at each stud intersection.
 1. Channel Bridging: Cold-rolled steel channel, welded or mechanically fastened to webs of punched studs.
 2. Strap Bridging: Combination of flat, taut, steel sheet straps of width and thickness indicated and stud-track solid blocking of width and thickness to match studs. Fasten flat straps to stud flanges and secure solid blocking to stud webs or flanges.
 3. Bar Bridging: Proprietary bridging bars installed according to manufacturer's written instructions.
 - F. Top Bridging for Single Deflection Track: Install row of horizontal bridging within 12 inches of single deflection track. Install a combination of bridging and stud or stud-track solid blocking of width and thickness matching studs, secured to stud webs or flanges.
 1. Install solid blocking at centers indicated on Shop Drawings.
 - G. Install miscellaneous framing and connections, including stud kickers, web stiffeners, clip angles, continuous angles, anchors, and fasteners, to provide a complete and stable wall-framing system.

6. INSTALLATION OF JOIST FRAMING

- A. Install perimeter joist track sized to match joists. Align and securely anchor or fasten track to supporting structure at corners, ends, and spacing indicated on Shop Drawings.
- B. Install joists bearing on supporting frame, level, straight, and plumb; adjust to final position, brace, and reinforce. Fasten joists to both flanges of joist track.
 - 1. Install joists over supporting frame with a minimum end bearing of 1-1/2 inches.
 - 2. Reinforce ends and bearing points of joists with web stiffeners, end clips, joist hangers, steel clip angles, or steel-stud sections.
- C. Space joists not more than 2 inches from abutting walls, and as follows:
 - 1. Joist Spacing: As indicated.
- D. Frame openings with built-up joist headers, consisting of joist and joist track or another combination of connected joists if indicated.
- E. Install joist reinforcement at interior supports with single, short length of joist section located directly over interior support, with lapped joists of equal length to joist reinforcement.
 - 1. Install web stiffeners to transfer axial loads of walls above.
- F. Install bridging at intervals indicated on Shop Drawings. Fasten bridging at each joist intersection as follows:
 - 1. Joist-Track Solid Bridging: Joist-track solid blocking of width and thickness indicated, secured to joist webs.
 - 2. Combination Bridging: Combination of flat, taut, steel sheet straps of width and thickness indicated and joist-track solid blocking of width and thickness indicated. Fasten flat straps to bottom flange of joists and secure solid blocking to joist webs.
- G. Secure joists to load-bearing interior walls to prevent lateral movement of bottom flange.
- H. Install miscellaneous joist framing and connections, including web stiffeners, closure pieces, clip angles, continuous angles, hold-down angles, anchors, and fasteners, to provide a complete and stable joist-framing assembly.

7. INSTALLATION TOLERANCES

- A. Install cold-formed steel framing level, plumb, and true to line to a maximum allowable tolerance variation of 1/8 inch in 10 feet and as follows:
 - 1. Space individual framing members no more than plus or minus 1/8 inch from plan location. Cumulative errors are not to exceed minimum fastening requirements of sheathing or other finishing materials.

8. REPAIR

- A. Galvanizing Repairs: Prepare and repair damaged galvanized coatings on fabricated and installed cold-formed steel framing with galvanized repair paint according to ASTM A780/A780M and manufacturer's written instructions.

9. FIELD QUALITY CONTROL

- A. Testing: Owner will engage a qualified independent testing and inspecting agency to perform field tests and inspections and prepare test reports.
- B. Field and shop welds will be subject to testing and inspecting.
- C. Testing agency will report test results promptly and in writing to Contractor and Architect.
- D. Cold-formed steel framing will be considered defective if it does not pass tests and inspections.
- E. Additional testing and inspecting, at Contractor's expense, will be performed to determine compliance of replaced or additional work with specified requirements.

10. PROTECTION

- A. Provide final protection and maintain conditions, in a manner acceptable to manufacturer and Installer, that ensure that cold-formed steel framing is without damage or deterioration at time of Substantial Completion.

END OF SECTION 054000

SECTION 057300 - DECORATIVE METAL RAILINGS

PART 1 - GENERAL

1.1 SUMMARY

A. Section Includes:

1. Steel and iron decorative railings.

B. Related Requirements:

1. Section 057313 "Glazed Decorative Metal Railings."
2. Section 061000 "Rough Carpentry" for wood blocking for anchoring railings.
3. Section 064023 "Interior Architectural Woodwork" for wood railings.

1.2 ACTION SUBMITTALS

A. Product Data:

1. Manufacturer's product lines of decorative metal railings assembled from standard components.
2. Fasteners.
3. Post-installed anchors.
4. Handrail brackets.
5. Wood rails.
6. Metal finishes.

B. Shop Drawings: Include plans, elevations, sections, and attachment details.

C. Samples for Initial Selection: For products involving selection of color, texture, or design, including mechanical finishes.

1.3 INFORMATIONAL SUBMITTALS

A. Qualification Data: For delegated design professional engineer.

B. Paint Compatibility Certificates: From manufacturers of topcoats applied over shop primers, certifying that shop primers are compatible with topcoats.

C. Product Test Reports: For tests on railings performed by a qualified testing agency, in accordance with ASTM E894 and ASTM E935.

D. Research Reports: For post-installed anchors, from ICC-ES or other qualified testing agency acceptable to authorities having jurisdiction.

1.4 QUALITY ASSURANCE

- A. Welding Qualifications: Qualify procedures and personnel in accordance with the following:
 - 1. AWS D1.1/D1.1M, "Structural Welding Code - Steel."

1.5 FIELD CONDITIONS

- A. Field Measurements: Verify actual locations of walls and other construction contiguous with railings by field measurements before fabrication.

PART 2 - PRODUCTS

2.1 PERFORMANCE REQUIREMENTS

- A. Structural Performance: Railings, including attachment to building construction, are to withstand the effects of gravity loads and the following loads and stresses within limits and under conditions indicated:
 - 1. Handrails and Top Rails of Guards:
 - a. Uniform load of **50 lbf/ft.** applied in any direction.
 - b. Concentrated load of **200 lbf** applied in any direction.
 - c. Uniform and concentrated loads need not be assumed to act concurrently.
 - 2. Infill of Guards:
 - a. Concentrated load of **50 lbf** applied horizontally on an area of **1 sq. ft.**
 - b. Infill load and other loads need not be assumed to act concurrently.

2.2 METALS, GENERAL

- A. Metal Surfaces, General: Provide materials with smooth surfaces, without seam marks, roller marks, rolled trade names, stains, discolorations, or blemishes.
- B. Brackets, Flanges, and Anchors: Same metal and finish as supported rails unless otherwise indicated.

2.3 STEEL AND IRON DECORATIVE RAILINGS

- A. Steel and Iron Decorative Railings:
 - 1. Basis-of-Design Product: Subject to compliance with requirements, provide HDI Railing: Ferric or Approved Equivalent by one of the following:

- a. Architectural Iron Designs, Inc.
 - b. Indital USA
 - c. Lawler Foundry Corporation
 - d. Livers Bronze Co.
 - e. Olin Metal Works
 - f. Regency Railings
 - g. Trex Commercial Products, Inc.
 - h. Tri Tech, Inc.
 - i. VIVA Railings, LLC
 - j. Wagner Companies (The); R&B Wagner, Inc.
 - k. Wiemann Metalcraft
2. Source Limitations: Obtain steel decorative railing components from single source from single manufacturer.
- B. Tubing: ASTM A500/A500M (cold formed) ASTM A513/A513M, Type 5.
 - C. Bars: Hot-rolled, carbon steel complying with ASTM A29/A29M, Grade 1010.
 - D. Plates, Shapes, and Bars: ASTM A36/A36M.
 - E. Cast Iron: Either gray iron, ASTM A48/A48M, or malleable iron, ASTM A47/A47M, unless otherwise indicated.

2.4 MISCELLANEOUS MATERIALS

- A. Wood Rails:
 1. Clear, straight-grained hardwood rails secured to exposed metal subrail.
 - a. Species: To Match Existing.
 - b. Finish: To Match Existing.
 - c. Staining: To Match Existing.
 - d. Profile: To Match Existing.
- B. Etching Cleaner for Galvanized Metal: Compatible with coating system specified.
- C. Galvanizing Repair Paint: High-zinc-dust-content paint compatible with coating system specified.
- D. Shop Primers: Provide primers that comply with Section 099123 "Interior Painting."
 1. Use primer containing pigments that make it easily distinguishable from zinc-rich primer.
- E. Epoxy Zinc-Rich Primer: Compatible with topcoat.
- F. Shop Primer for Galvanized Steel: Coordinate with finish coat.
- G. Intermediate Coats and Topcoats: Provide products that comply with Section 099123

"Interior Painting."

- H. Epoxy Intermediate Coat: Compatible with primer and topcoat.
- I. Polyurethane Topcoat: Compatible with undercoat.
- J. Bituminous Paint: Cold-applied asphalt emulsion complying with ASTM D1187/D1187M.
- K. Nonshrink, Nonmetallic Grout: Factory-packaged, nonstaining, noncorrosive, nongaseous grout complying with ASTM C1107/C1107M. Provide grout specifically recommended by manufacturer for interior and exterior applications.
- L. Anchoring Cement: Factory-packaged, nonshrink, nonstaining, hydraulic-controlled expansion cement formulation for mixing with water at Project site to create pourable anchoring, patching, and grouting compound.

2.5 FABRICATION

- A. Fabricate railings to comply with requirements indicated for design, dimensions, member sizes and spacing, details, finish, and anchorage, but not less than that required to support structural loads.
- B. Shop assemble railings to greatest extent possible to minimize field splicing and assembly. Disassemble units only as necessary for shipping and handling limitations.
 - 1. Clearly mark units for reassembly and coordinated installation.
 - 2. Use connections that maintain structural value of joined pieces.
- C. Cut, drill, and punch metals cleanly and accurately.
 - 1. Remove burrs and ease edges to a radius of approximately **1/32 inch** unless otherwise indicated.
 - 2. Remove sharp or rough areas on exposed surfaces.
- D. Form work true to line and level with accurate angles and surfaces.
- E. Fabricate connections that will be exposed to weather in a manner to exclude water.
 - 1. Provide weep holes where water may accumulate.
 - 2. Locate weep holes in inconspicuous locations.
- F. Cut, reinforce, drill, and tap as indicated to receive finish hardware, screws, and similar items.
- G. Connections: Fabricate railings with mechanical connections unless otherwise indicated.
- H. Welded Connections for Aluminum Pipe: Fabricate railings to interconnect members with concealed internal welds that eliminate surface grinding, using manufacturer's

standard system of sleeve and socket fittings.

- I. Brazed Connections: Connect copper and copper-alloy railings by brazing. Cope components at connections to provide close fit, or use fittings designed for this purpose. Braze corners and seams continuously.
 - 1. Use materials and methods that match color of base metal, minimize distortion, and develop maximum strength and corrosion resistance.
 - 2. Remove flux immediately.
 - 3. At exposed connections, finish exposed surfaces smooth and blended, so no roughness shows after finishing and brazed surface matches contours of adjoining surfaces.
- J. Mechanical Connections: Connect members with concealed mechanical fasteners and fittings.
 - 1. Fabricate members and fittings to produce flush, smooth, rigid, hairline joints.
 - 2. Fabricate splice joints for field connection using an epoxy structural adhesive if this is manufacturer's standard splicing method.
- K. Form changes in direction as follows:
 - 1. As detailed.
 - 2. By radius bends of radius indicated.
- L. Bend members in jigs to produce uniform curvature for each configuration required. Maintain cross section of member throughout entire bend without buckling, twisting, cracking, or otherwise deforming exposed surfaces of components.
- M. Close exposed ends of hollow railing members with prefabricated cap and end fittings of same metal and finish as railings.
- N. Provide wall returns at ends of wall-mounted handrails unless otherwise indicated. Close ends of returns, unless clearance between end of rail and wall is **1/4 inch** or less.
- O. Brackets, Flanges, Fittings, and Anchors: Provide wall brackets, flanges, handrail brackets, miscellaneous fittings, and anchors to interconnect railing members to other Work unless otherwise indicated.
 - 1. At brackets and fittings fastened to plaster or gypsum board partitions, provide crush-resistant fillers or other means to transfer loads through wall finishes to structural supports and to prevent bracket or fitting rotation and crushing of substrate.
- P. Provide inserts and other anchorage devices for connecting railings to concrete or masonry Work.
 - 1. Fabricate anchorage devices capable of withstanding loads imposed by railings.
 - 2. Coordinate anchorage devices with supporting structure.
- Q. For railing posts set in concrete, provide stainless steel sleeves not less than **6 inches**

long with inside dimensions not less than **1/2 inch** greater than outside dimensions of post, with metal plate forming bottom closure.

- R. For removable railing posts, fabricate slip-fit sockets from stainless steel tube or pipe whose ID is sized for a close fit with posts; limit movement of post without lateral load, measured at top, to not more than one-fortieth of post height.
 - 1. Provide socket covers designed and fabricated to resist being dislodged.
 - 2. Provide chain with eye, snap hook, and staple across gaps formed by removable railing sections at locations indicated. Fabricate from same metal as railings.
- S. Stainless Steel Cable Guard Infill: Fabricate cable guard infill assemblies in the shop to field-measured dimensions with fittings machine swaged.
 - 1. Minimize amount of turnbuckle take-up used for dimensional adjustment, so maximum amount is available for tensioning cable.
 - 2. Tag cable assemblies and fittings to identify installation locations and orientations for coordinated installation.
- T. Toe Boards: Where indicated on Drawings, provide toe boards at railings around openings and at edge of open-sided floors and platforms. Fabricate to dimensions and details indicated.

2.6 GENERAL FINISH REQUIREMENTS

- A. Comply with NAAMM's "Metal Finishes Manual for Architectural and Metal Products" recommendations for applying and designating finishes.
- B. Protect mechanical finishes on exposed surfaces from damage by applying a strippable, temporary protective covering before shipment.
- C. Appearance of Finished Work: Noticeable variations in same piece are unacceptable. Variations in appearance of abutting or adjacent pieces are acceptable if they are within one-half of the range of approved Samples. Variations in appearance of other components are acceptable if they are within the range of approved Samples and are assembled or installed to minimize contrast.
- D. Provide exposed fasteners with finish matching appearance, including color and texture, of railings.

2.7 STEEL AND IRON FINISHES

- A. Galvanized Railings:
 - 1. Hot-dip galvanize indicated steel and iron railings, including hardware, after fabrication.
 - 2. Comply with ASTM A123/A123M for hot-dip galvanized railings.
 - 3. Comply with ASTM A153/A153M for hot-dip galvanized hardware.
 - 4. Do not quench or apply post-galvanizing treatments that might interfere with paint

- adhesion.
5. Fill vent and drain holes that are exposed in the finished Work, unless indicated to remain as weep holes, by plugging with zinc solder and filing off smooth.
- B. For galvanized railings, provide hot-dip galvanized fittings, brackets, fasteners, sleeves, and other ferrous components.
- C. Preparing Galvanized Railings for Shop Priming: After galvanizing, thoroughly clean railings of grease, dirt, oil, flux, and other foreign matter, and treat with etching cleaner and as follows:
1. Comply with SSPC-SP 16.
- D. For nongalvanized-steel railings, provide nongalvanized ferrous-metal fittings, brackets, fasteners, and sleeves; however, hot-dip galvanize anchors to be embedded in exterior concrete or masonry.
- E. Preparation for Shop Priming: Prepare uncoated ferrous-metal surfaces to comply with SSPC-SP 6/NACE No. 3.
1. Railings Indicated To Receive Zinc-Rich Primer: SSPC-SP 6/NACE No. 3.
 2. Railings Indicated To Receive Primers Specified in Section 099600 "High-Performance Coatings": SSPC-SP 6/NACE No. 3.
 3. Other Railings: SSPC-SP 7/NACE No. 4.
- F. Primer Application: Apply shop primer to prepared surfaces of railings unless otherwise indicated. Comply with requirements in SSPC-PA 1 for shop painting. Primer need not be applied to surfaces to be embedded in concrete or masonry.
1. Shop prime uncoated railings with primers specified in Section 099113 "Exterior Painting" unless indicated.
- G. Shop-Painted Finish: Comply with Section 099113 "Exterior Painting."
1. Color: Match Architect's sample.

PART 3 - EXECUTION

3.1 INSTALLATION, GENERAL

- A. Perform cutting, drilling, and fitting required for installing railings.
1. Fit exposed connections together to form tight, hairline joints.
 2. Install railings level, plumb, square, true to line; without distortion, warp, or rack.
 3. Set railings accurately in location, alignment, and elevation; measured from established lines and levels.
 4. Do not weld, cut, or abrade surfaces of railing components that have been coated or finished after fabrication and that are intended for field connection by mechanical or other means without further cutting or fitting.

5. Set posts plumb within a tolerance of **1/16 inch in 3 feet**.
 6. Align rails so variations from level for horizontal members and variations from parallel with rake of steps and ramps for sloping members do not exceed **1/4 inch in 12 feet**.
- B. Control of Corrosion: Prevent galvanic action and other forms of corrosion by insulating metals and other materials from direct contact with incompatible materials.
1. Coat concealed surfaces of aluminum that will be in contact with grout, concrete, masonry, wood, or dissimilar metals, with a heavy coat of bituminous paint.
- C. Adjust railings before anchoring to ensure matching alignment at abutting joints.
- D. Fastening to In-Place Construction: Use anchorage devices and fasteners where necessary for securing railings and for properly transferring loads to in-place construction.

END OF SECTION 057300

SECTION 057313 - GLAZED DECORATIVE METAL RAILINGS

PART 1 - GENERAL

1.1 SUMMARY

A. Section Includes:

1. Glazed decorative metal railings.

B. Related Requirements:

1. Section 061000 "Rough Carpentry" for wood blocking for anchoring railings.

1.2 ACTION SUBMITTALS

A. Product Data:

1. Stainless Steel Glass Railing System

B. Shop Drawings: Include plans, elevations, sections, and attachment details.

C. Samples for Initial Selection: For products involving selection of color, texture, or design.

1.3 INFORMATIONAL SUBMITTALS

A. Product Test Reports: For tests performed by a qualified testing agency, in accordance with ASTM E894, ASTM E935, ASTM E2353, and ASTM E2358.

B. Evaluation Reports: From ICC-ES or other qualified testing agency acceptable to authorities having jurisdiction.

1. For glazed decorative metal railings.
2. For post-installed anchors.

1.4 FIELD CONDITIONS

A. Field Measurements: Verify actual locations of walls and other construction contiguous with railings by field measurements before fabrication and indicate measurements on Shop Drawings.

1.5 WARRANTY

- A. **Manufacturer's Special Warranty for Laminated Glass:** Glazed decorative metal railing manufacturer agrees to replace laminated-glass units that deteriorate within specified warranty period. Deterioration of laminated glass is defined as defects developed from normal use that are not attributed to glass breakage or to maintaining and cleaning laminated glass contrary to manufacturer's written instructions. Defects include edge separation, delamination materially obstructing vision through glass, and blemishes exceeding those allowed by referenced laminated-glass standard.
1. Warranty Period: 10 years from date of Substantial Completion.

PART 2 - PRODUCTS

2.1 PERFORMANCE REQUIREMENTS

- A. **General:** In engineering railings to withstand structural loads indicated, determine allowable design working stresses of railing materials based on the following:
1. Aluminum: The lesser of minimum yield strength divided by 1.65, or minimum ultimate tensile strength divided by 1.95.
 2. Copper Alloys: 60 percent of minimum yield strength.
 3. Stainless Steel: 60 percent of minimum yield strength.
 4. Steel: 72 percent of minimum yield strength.
- B. **Structural Performance:** Railings, including attachment to building construction, are to withstand the effects of gravity loads and the following loads and stresses within limits and under conditions indicated:
1. **Handrails and Top Rails of Guards:**
 - a. Uniform load of **50 lbf/ft.** applied in any direction.
 - b. Concentrated load of **200 lbf** applied in any direction.
 - c. Uniform and concentrated loads need not be assumed to act concurrently.
 2. **Structural Glass Railings and Glass-Infill Panels:**
 - a. Concentrated load of **50 lbf** applied horizontally on an area of **1 sq. ft.**
 - b. Infill load and other loads need not be assumed to act concurrently.

2.2 GLAZED DECORATIVE METAL RAILINGS

- A. **Basis-of-Design Product:** Subject to compliance with requirements, provide Viewrail Signature Posts, Special Application Mount, 6000 Wood Top Rail, Flat Top Post, Glass Infill, 316 SS Post or Approved Equivalent by one of the following:
1. ATR Technologies, Inc.
 2. C.R. Laurence Co., Inc.; CRH Americas, Inc.

3. CraneVeyor Corp
4. Glass Vice USA
5. Greco; CSW Industrials Inc.
6. Hollaender Architectural Railing Systems; Hollaender Mfg. Co.
7. Hollaender Mfg. Co.
8. Julius Blum & Co., Inc.
9. Livers Bronze Co.
10. Morse Industries
11. Southwest Metalsmiths, Inc.
12. TACO Metals Inc.
13. Trex Commercial Products, Inc.
14. Tri Tech, Inc.
15. Tuttle, a Dant Clayton Division
16. VIVA Railings, LLC
17. Wagner Companies (The); R&B Wagner, Inc.

- B. Source Limitations for Laminated Glass: Obtain from single source from single manufacturer.
- C. Source Limitations for Decorative Metal Railing Components: Obtain from single source from single manufacturer for each component and installation method.
- D. Product Options: Information on Drawings and in the Specifications establishes requirements for railing system's aesthetic effects and performance characteristics. Aesthetic effects are indicated by dimensions, arrangements, alignment, and profiles of components and assemblies as they relate to sightlines, to one another, and to adjoining construction.
1. Do not change intended aesthetic effects, as judged solely by Architect, except with Architect's approval. If changes are proposed, submit comprehensive explanatory data to Architect for review.

2.3 METALS, GENERAL

- A. Metal Surfaces, General: Provide materials with smooth surfaces, without seam marks, roller marks, rolled trade names, stains, discolorations, or blemishes.
- B. Brackets, Flanges, and Anchors: Same metal and finish as supported rails unless otherwise indicated.

2.4 FABRICATION OF METAL RAILINGS

- A. Fabricate railings to comply with requirements indicated for design, dimensions, member sizes and spacing, details, finish, and anchorage, but not less than that required to support structural loads.
- B. Assemble railings in the shop to greatest extent possible to minimize field splicing and assembly. Disassemble units only as necessary for shipping and handling limitations. Clearly mark units for reassembly and coordinated installation. Use connections that

maintain structural value of joined pieces.

- C. Cut, drill, and punch metals cleanly and accurately. Remove burrs and ease edges to a radius of approximately **1/32 inch** unless otherwise indicated. Remove sharp or rough areas on exposed surfaces.
- D. Form work true to line and level with accurate angles and surfaces.
- E. Fabricate connections that will be exposed to weather in a manner to exclude water. Provide weep holes where water may accumulate. Locate weep holes in inconspicuous locations.
- F. Cut, reinforce, drill, and tap as indicated to receive finish hardware, screws, and similar items.
- G. Mechanical Connections: Connect members with concealed mechanical fasteners and fittings. Fabricate members and fittings to produce flush, smooth, rigid, hairline joints.
 - 1. Fabricate splice joints for field connection using an epoxy structural adhesive if this is manufacturer's standard splicing method.
- H. Form changes in direction as follows:
- I. Close exposed ends of hollow railing members with prefabricated end fittings.
- J. Brackets, Flanges, Fittings, and Anchors: Provide wall brackets, flanges, handrail brackets, miscellaneous fittings, and anchors to interconnect railing members to other work where indicated.
 - 1. At brackets and fittings fastened to plaster or gypsum board partitions, provide crush-resistant fillers, or other means to transfer loads through wall finishes to structural supports and to prevent bracket or fitting rotation and crushing of substrate.
- K. Provide inserts and other anchorage devices for connecting railings to concrete or masonry work. Fabricate anchorage devices capable of withstanding loads imposed by railings. Coordinate anchorage devices with supporting structure.

2.5 METAL FINISH REQUIREMENTS, GENERAL

- A. Protect mechanical finishes on exposed surfaces from damage by applying a strippable, temporary protective covering before shipment.
- B. Appearance of Finished Work: Noticeable variations in same piece are not acceptable. Variations in appearance of abutting or adjacent pieces are acceptable if they are within one-half of the range of approved Samples. Variations in appearance of other components are acceptable if they are within the range of approved Samples and are assembled or installed to minimize contrast.
- C. Provide exposed fasteners with finish matching appearance, including color and

texture, of railings.

2.6 STAINLESS STEEL FINISHES

- A. Material: 6061 Aluminum (Aircraft Grade)
- B. Post Gauge: 316SS 7 Gauge

PART 3 - EXECUTION

3.1 INSTALLATION, GENERAL

- A. Comply with Drawings and manufacturer's written instructions for installing glazed decorative metal railings, accessories, and other components.
- B. Perform cutting, drilling, and fitting required for installing metal railings.
 - 1. Fit exposed connections together to form tight, hairline joints.
 - 2. Install railings level, plumb, square, true to line; without distortion, warp, or rack.
 - 3. Set railings accurately in location, alignment, and elevation; measured from established lines and levels.
 - 4. Do not weld, cut, or abrade surfaces of metal railing components that have been coated or finished after fabrication and that are intended for field connection by mechanical or other means without further cutting or fitting.
 - 5. Set posts plumb within a tolerance of **1/16 inch in 3 feet**.
 - 6. Align rails so variations from level for horizontal members and variations from parallel with rake of steps and ramps for sloping members do not exceed **1/4 inch in 12 feet**.
- C. Control of Corrosion: Prevent galvanic action and other forms of corrosion by insulating metals and other materials from direct contact with incompatible materials.
 - 1. Coat concealed surfaces of aluminum that will be in contact with grout, concrete, masonry, wood, or dissimilar metals, with shop primer bituminous paint.
- D. Adjust railings before anchoring to ensure matching alignment at abutting joints.
- E. Fastening to In-Place Construction: Use anchorage devices and fasteners where necessary for securing railings and for properly transferring loads to in-place construction.

END OF SECTION 057313

SECTION 061000 - ROUGH CARPENTRY

PART 1 - GENERAL

1.1 SUMMARY

- A. Section Includes:
1. Wood-preservative-treated lumber.
 2. Fire-retardant-treated lumber.
 3. Miscellaneous lumber.
 4. Plywood backing panels.

1.2 DELIVERY, STORAGE, AND HANDLING

- A. Stack wood products flat with spacers beneath and between each bundle to provide air circulation. Protect wood products from weather by covering with waterproof sheeting, securely anchored. Provide for air circulation around stacks and under coverings.

PART 2 - PRODUCTS

2.1 WOOD PRODUCTS

- A. Lumber: Comply with DOC PS 20 and applicable rules of grading agencies indicated. If no grading agency is indicated, comply with the applicable rules of any rules-writing agency certified by the ALSC Board of Review. Grade lumber by an agency certified by the ALSC Board of Review to inspect and grade lumber under the rules indicated.
1. Factory mark each piece of lumber with grade stamp of grading agency.
 2. For exposed lumber indicated to receive a stained or natural finish, mark grade stamp on end or back of each piece.
 3. Where nominal sizes are indicated, provide actual sizes required by DOC PS 20 for moisture content specified. Where actual sizes are indicated, they are minimum dressed sizes for dry wood products.
 4. Dress lumber, S4S, unless otherwise indicated.
- B. Maximum Moisture Content:
1. Boards: 15 percent.
 2. Dimension Lumber: 15 percent unless otherwise indicated.

2.2 FIRE-RETARDANT-TREATED LUMBER

- A. General: Where fire-retardant-treated materials are indicated, materials are to comply

with requirements in this article, that are acceptable to authorities having jurisdiction, and with fire-test-response characteristics specified as determined by testing identical products per test method indicated by a qualified testing agency.

- B. Fire-Retardant-Treated Lumber and Plywood by Pressure Process: Products with a flame-spread index of 25 or less when tested in accordance with ASTM E84, and with no evidence of significant progressive combustion when the test is extended an additional 20 minutes, and with the flame front not extending more than **10.5 feet** beyond the centerline of the burners at any time during the test.
 - 1. Treatment is not to promote corrosion of metal fasteners.
 - 2. Interior Type A: Treated materials are to have a moisture content of 28 percent or less when tested in accordance with ASTM D3201/D3201M at 92 percent relative humidity. Use where exterior type is not indicated.
 - 3. Design Value Adjustment Factors: Treated lumber is to be tested according to ASTM D5664 and design value adjustment factors are to be calculated according to ASTM D6841. For enclosed roof framing, framing in attic spaces, and where high temperature fire-retardant treatment is indicated, provide material with adjustment factors of not less than 0.85 modulus of elasticity and 0.75 for extreme fiber in bending for Project's climatological zone.
- C. Kiln-dry lumber after treatment to maximum moisture content of 19 percent.
- D. Identify fire-retardant-treated wood with appropriate classification marking of qualified testing agency and other information required by authorities having jurisdiction.
- E. Application: Treat items indicated on Drawings, and the following:
 - 1. Concealed blocking.
 - 2. Plywood backing panels.

2.3 MISCELLANEOUS LUMBER

- A. Provide miscellaneous lumber indicated and lumber for support or attachment of other construction, including the following:
 - 1. Blocking.
 - 2. Rooftop equipment bases and support curbs.
- B. Dimension Lumber Items: Construction or No. 2 grade lumber of any species.
 - 1. Hem-fir (north); NLGA.
 - 2. Mixed southern pine or southern pine; SPIB.
 - 3. Spruce-pine-fir; NLGA.
 - 4. Hem-fir; WCLIB or WWPA.
 - 5. Spruce-pine-fir (south); NeLMA, WCLIB, or WWPA.
 - 6. Western woods; WCLIB or WWPA.
 - 7. Northern species; NLGA.
 - 8. Eastern softwoods; NeLMA.

2.4 PLYWOOD BACKING PANELS

- A. Equipment Backing Panels: Plywood, DOC PS 1, Exterior, A-C, fire-retardant treated, in thickness indicated or, if not indicated, not less than **3/4-inch** nominal thickness.

PART 3 - EXECUTION

3.1 INSTALLATION

- A. Framing Standard: Comply with AF&PA's WCD 1, "Details for Conventional Wood Frame Construction," unless otherwise indicated.
- B. Set work to required levels and lines, with members plumb, true to line, cut, and fitted. Fit rough carpentry accurately to other construction. Locate nailers, blocking, grounds, and similar supports to comply with requirements for attaching other construction.
- C. Install plywood backing panels by fastening to studs; coordinate locations with utilities requiring backing panels.
- D. Install metal framing anchors to comply with manufacturer's written instructions. Install fasteners through each fastener hole.
- E. Do not splice structural members between supports unless otherwise indicated.
- F. Provide blocking and framing as indicated and as required to support facing materials, fixtures, specialty items, and trim.
- G. Sort and select lumber so that natural characteristics do not interfere with installation or with fastening other materials to lumber. Do not use materials with defects that interfere with function of member or pieces that are too small to use with minimum number of joints or optimum joint arrangement.
- H. Where wood-preserved-treated lumber is installed adjacent to metal decking, install continuous flexible flashing separator between wood and metal decking.
- I. Securely attach rough carpentry work to substrate by anchoring and fastening as indicated, complying with the following:
 - 1. Table 2304.10.1, "Fastening Schedule," in ICC's International Building Code (IBC).
 - 2. ICC-ES evaluation report for fastener.

3.2 INSTALLATION OF WOOD BLOCKING AND NAILERS

- A. Install where indicated and where required for attaching other work. Form to shapes indicated and cut as required for true line and level of attached work. Coordinate locations with other work involved.

- B. Attach wood blocking to substrates to support applied loading. Recess bolts and nuts flush with surfaces unless otherwise indicated.
- C. Attach wood roofing nailers securely to substrate to resist the designed outward and upward wind loads indicated on Drawings and in accordance with ANSI/SPRI ED-1, Tables A6 and A7.

3.3 INSTALLATION OF WOOD FURRING

- A. Install level and plumb with closure strips at edges and openings. Shim with wood as required for tolerance of finish work.

3.4 PROTECTION

- A. Protect wood that has been treated with inorganic boron (SBX) from weather. If, despite protection, inorganic boron-treated wood becomes wet, apply EPA-registered borate treatment. Apply borate solution by spraying to comply with EPA-registered label.

END OF SECTION 061000

SECTION 062023 - INTERIOR FINISH CARPENTRY

PART 1 - GENERAL

1.1 SUMMARY

A. Related Requirements:

1. Section 061000 "Rough Carpentry" for furring, blocking, and other carpentry work not exposed to view and for framing exposed to view.
2. Section 064023 "Interior Architectural Woodwork" for shop-fabricated carpentry.
3. Section 099123 "Interior Painting" for priming and backpriming of interior finish carpentry.

1.2 ACTION SUBMITTALS

A. Product Data:

1. Interior trim.

B. Product Data Submittals: For each type of process and factory-fabricated product. Indicate component materials, dimensions, profiles, textures, and colors and include construction and application details.

1. Include data for wood-preservative treatment from chemical-treatment manufacturer and certification by treating plant that treated materials comply with requirements. Indicate type of preservative used and net amount of preservative retained. Include chemical-treatment manufacturer's written instructions for finishing treated material.
2. For products receiving a waterborne treatment, include statement that moisture content of treated materials was reduced before shipment to Project site to levels specified.

C. Samples: For each exposed product and for each color and texture specified.

1.3 QUALITY ASSURANCE

1.4 FIELD CONDITIONS

- A. Environmental Limitations: Do not deliver or install interior finish carpentry materials until building is enclosed and weatherproof, wet-work in space is completed and nominally dry, and HVAC system is operating and maintaining temperature and relative humidity at occupancy levels during the remainder of the construction period.
- B. Do not install finish carpentry materials that are wet, moisture damaged, or mold damaged.

1. Indications that materials are wet or moisture damaged include, but are not limited to, discoloration, sagging, or irregular shape.
2. Indications that materials are mold damaged include, but are not limited to, fuzzy or splotchy surface contamination and discoloration.

PART 2 - PRODUCTS

2.1 MATERIALS, GENERAL

- A. Lumber: DOC PS 20 and applicable rules of grading agencies indicated. If no grading agency is indicated, comply with applicable rules of any rules-writing agency certified by the American Lumber Standard Committee's (ALSC) Board of Review. Grade lumber by an agency certified by the ALSC's Board of Review to inspect and grade lumber under the rules indicated.
 1. Factory mark each piece of lumber with grade stamp of grading agency.
 2. For exposed lumber, mark grade stamp on end or back of each piece.
- B. Softwood Plywood: DOC PS 1.
- C. Hardboard: ANSI A135.4.
- D. MDF: ANSI A208.2, Grade 130.
- E. Particleboard: ANSI A208.1, Grade M-2.
- F. Melamine-Faced Particleboard: Particleboard complying with ANSI A208.1, Grade M-2, finished on both faces with thermally fused, melamine-impregnated decorative paper and complying with ISO 4586-3, Grade VGS.
 1. Color: White.

2.2 WOOD-PRESERVATIVE-TREATED MATERIALS

- A. Preservative Treatment by Pressure Process: AWPA U1; Use Category UC1 UC2.
 1. Kiln dry lumber and plywood after treatment to a maximum moisture content of 19 and 18 percent, respectively.
 2. Preservative Chemicals: Acceptable to authorities having jurisdiction.
 3. For exposed items indicated to receive transparent finish, do not use chemical formulations that contain colorants or that bleed through or otherwise adversely affect finishes.
 4. Do not use material that is warped or does not comply with requirements for untreated material.
 5. Mark plywood with appropriate classification marking of an inspection agency acceptable to authorities having jurisdiction.
 - a. For exposed plywood indicated to receive a stained or natural finish, mark

back of each piece.

6. Application: All interior lumber and plywood.

2.3 MISCELLANEOUS MATERIALS

- A. Fasteners for Interior Finish Carpentry: Nails, screws, and other anchoring devices of type, size, material, and finish required for application indicated to provide secure attachment, concealed where possible.
- B. Glue: Aliphatic-resin, polyurethane, or resorcinol wood glue recommended by manufacturer for general carpentry use.
- C. Installation Adhesive for Foam-Plastic Moldings: Product recommended for indicated use by foam-plastic molding manufacturer.
- D. Paneling Adhesive: Comply with paneling manufacturer's written instructions for adhesives.
- E. Multipurpose Construction Adhesive: Formulation, complying with ASTM D3498, that is recommended for indicated use by adhesive manufacturer.

2.4 FABRICATION

- A. Back out or kerf backs of the following members, except those with ends exposed in finished work:
 1. Interior standing and running trim, except shoe and crown molds.
 2. Wood-board paneling.
- B. Ease edges of lumber less than **1 inch** in nominal thickness to **1/16-inch** radius and edges of lumber **1 inch** or more in nominal thickness to **1/8-inch** radius.

PART 3 - EXECUTION

3.1 INSTALLATION, GENERAL

- A. Do not use materials that are unsound; warped; improperly treated or finished; inadequately seasoned; too small to fabricate with proper jointing arrangements; or with defective surfaces, sizes, or patterns.
- B. Install interior finish carpentry level, plumb, true, and aligned with adjacent materials.
 1. Use concealed shims where necessary for alignment.
 2. Scribe and cut interior finish carpentry to fit adjoining work. Refinish and seal cuts as recommended by manufacturer.
 3. Where face fastening is unavoidable, countersink fasteners, fill surface flush, and

- sand unless otherwise indicated.
4. Install to tolerance of **1/8 inch in 96 inches** for level and plumb. Install adjoining interior finish carpentry with **1/32-inch** maximum offset for flush installation and **1/16-inch** maximum offset for reveal installation.
 5. Coordinate interior finish carpentry with materials and systems in or adjacent to it. Provide cutouts for mechanical and electrical items that penetrate interior finish carpentry.

END OF SECTION 062023

SECTION 064023 - INTERIOR ARCHITECTURAL WOODWORK

PART 1 - GENERAL

1.1 SUMMARY

A. Section Includes:

1. Interior standing and running trim for transparent finish.
2. Interior standing and running trim for opaque finish.
3. Preservative-treated wood material.
4. Miscellaneous materials.
5. Shop priming.
6. Shop finishing.

B. Related Requirements:

1. Section 061000 "Rough Carpentry" for wood furring, blocking, shims, and hanging strips required for installing interior architectural woodwork that are concealed within other construction before interior architectural woodwork installation.
2. Section 062023 "Interior Finish Carpentry" for interior carpentry exposed to view that is not specified in this Section.

1.2 COORDINATION

- ##### A. Coordinate sizes and locations of framing, blocking, furring, reinforcements, and other related units of Work specified in other Sections, to ensure that interior architectural woodwork can be supported and installed as indicated.

1.3 ACTION SUBMITTALS

A. Product Data:

1. Anchors.
2. Adhesives.
3. Shop finishing materials.

- ##### B. Waterborne Treatments: For products receiving a waterborne treatment, include statement that moisture content of treated materials was reduced to levels specified before shipment to Project site.

C. Shop Drawings:

1. Include the following:

- a. Dimensioned plans, elevations, and sections.
 - b. Attachment details.
2. Show large-scale details.
 3. Show locations and sizes of furring, blocking, and hanging strips, including blocking and reinforcement concealed by construction and specified in other Sections.
 4. Apply AWI Quality Certification Program label to Shop Drawings.
- D. Samples: For each exposed product and for each shop-applied color and finish specified.
1. Size:
 - a. Panel Products: **12 inches by 12 inches**.
 - b. Lumber Products: Not less than **5 inches** wide by **12 inches** long, for each species and cut, finished on one side and one edge.

1.4 INFORMATIONAL SUBMITTALS

- A. Qualification Data: For architectural woodwork manufacturer and Installer.
- B. Product Certificates: For the following:
 1. Composite wood products.
 2. Adhesives.

1.5 CLOSEOUT SUBMITTALS

- A. Quality Standard Compliance Certificates: AWI Quality Certification Program certificates.

1.6 QUALITY ASSURANCE

- A. Manufacturer's Qualifications: Employs skilled workers who custom fabricate products similar to those required for this Project and whose products have a record of successful in-service performance.
 1. Manufacturer's Certification: Licensed participant in AWI's Quality Certification Program.
 2. Installer Qualifications: Manufacturer of products and Licensed participant in AWI's Quality Certification Program.

1.7 DELIVERY, STORAGE, AND HANDLING

- A. Comply with the Architectural Woodwork Standards, Section 2.

- B. Do not deliver interior architectural woodwork until painting and similar finish operations that might damage woodwork have been completed in installation areas.
- C. Store woodwork in installation areas or in areas where environmental conditions comply with requirements specified in "Field Conditions" Article.
 - 1. Handle and store fire-retardant-treated wood to comply with chemical treatment manufacturer's written instructions.

1.8 FIELD CONDITIONS

- A. Environmental Limitations without Humidity Control: Do not deliver or install interior architectural woodwork until building is enclosed, wet-work is complete, and HVAC system is operating and maintaining temperature and relative humidity at levels designed for building occupants for the remainder of the construction period.
- B. Environmental Limitations with Humidity Control: Do not deliver or install interior architectural woodwork until building is enclosed, wet-work is complete, and HVAC system is operating and maintaining temperature between **60 and 90 deg F** and relative humidity between 25 and 55 percent during the remainder of the construction period.
- C. Field Measurements: Where interior architectural woodwork is indicated to fit to other construction, verify dimensions of other construction by field measurements before fabrication, and indicate measurements on Shop Drawings.
 - 1. Locate concealed framing, blocking, and reinforcements that support woodwork by field measurements before being concealed by construction, and indicate measurements on Shop Drawings.
- D. Established Dimensions: Where interior architectural woodwork is indicated to fit to other construction, establish dimensions for areas where woodwork is to fit. Provide allowance for trimming at site, and coordinate construction to ensure that actual dimensions correspond to established dimensions.

PART 2 - PRODUCTS

2.1 PERFORMANCE REQUIREMENTS

- A. Fire-Rated Frames: Complying with NFPA 80 and listed and labeled by a qualified testing agency acceptable to authorities having jurisdiction for fire-protection ratings indicated on Drawings, based on testing at positive pressure in accordance with NFPA 252 or UL 10C.
 - 1. Smoke- and Draft-Control Assemblies: Listed and labeled for smoke and draft control by a qualified testing agency acceptable to authorities having jurisdiction, based on testing in accordance with UL 1784 and installed in compliance with NFPA 105.

- B. Fire-Rated, Borrowed-Lite Assemblies: Complying with NFPA 80 and listed and labeled by a qualified testing agency acceptable to authorities having jurisdiction, for fire-protection ratings indicated, based on testing in accordance with NFPA 257 or UL 9.

2.2 WOODWORK, GENERAL

- A. Quality Standard: Unless otherwise indicated, comply with the Architectural Woodwork Standards for grades of interior architectural woodwork indicated for construction, finishes, installation, and other requirements.
 - 1. Provide labels and certificates from AWI certification program indicating that woodwork and installation complies with requirements of grades specified.
 - 2. The Contract Documents contain requirements that are more stringent than the Architectural Woodwork Standards. Comply with Contract Documents and Architectural Woodwork Standards.

2.3 INTERIOR STANDING AND RUNNING TRIM FOR TRANSPARENT FINISH

- A. Architectural Woodwork Standards Grade: Custom.
- B. Hardwood Lumber:
 - 1. Wood Species and Cut: Match species and cut indicated for other types of transparent-finished architectural woodwork located in same area of building unless otherwise indicated.
 - 2. Species: Per schedule.
 - 3. Cut: Plain sliced/plain sawn.
 - 4. Wood Moisture Content: 5 to 10 percent.
 - 5. For trim items wider than available lumber, use veneered construction. Do not glue for width.
 - 6. For rails thicker than available lumber, use veneered construction. Do not glue for thickness.
- C. Softwood Lumber:
 - 1. Wood Species and Cut: Match species and cut indicated for other types of transparent-finished architectural woodwork located in same area of building unless otherwise indicated.
 - 2. Species: Per Schedule.
 - 3. Cut: Plain sawn.
 - 4. Wood Moisture Content: 5 to 10 percent.
 - 5. For base wider than available lumber, glue for width. Do not use veneered construction.
 - 6. For rails thicker than available lumber, use veneered construction. Do not glue for thickness.
 - 7. Do not use plain-sawn softwood lumber with exposed, flat surfaces more than **3 inches** wide.

2.4 INTERIOR STANDING AND RUNNING TRIM FOR OPAQUE FINISH

- A. Architectural Woodwork Standards Grade: Custom.
1. Wood Species: Any closed-grain hardwood.
 2. Wood Moisture Content: 5 to 10 percent.
- B. Architectural Woodwork Standards Grade: [Premium][Custom][Economy].
- C. Wood for Transparent Finish:
1. Species and Cut:
 - a. Stringers: [Red oak, plain sawn][Red oak, quarter sawn][Hard maple, plain sawn]<Insert species and cut>.
 - b. Risers: [Red oak, plain sawn][Red oak, quarter sawn][Hard maple, plain sawn]<Insert species and cut>.
 - c. Treads: [Red oak, plain sawn][Red oak, quarter sawn][Hard maple, plain sawn]<Insert species and cut>.
 - d. Railings: [Red oak, plain sawn][Red oak, quarter sawn][Hard maple, plain sawn]<Insert species and cut>.
 - e. Balusters: [Red oak, plain sawn][Red oak, quarter sawn][Hard maple, plain sawn]<Insert species and cut>.
 - f. Newels: [Red oak, plain sawn][Red oak, quarter sawn][Hard maple, plain sawn]<Insert species and cut>.
 - g. Moldings: [Red oak, plain sawn][Red oak, quarter sawn][Hard maple, plain sawn]<Insert species and cut>.
 2. Wood Moisture Content: [5 to 10][8 to 13][4 to 9] percent.
- D. Wood for Opaque Finish:
1. Species: [Any closed-grain hardwood][Eastern white pine, sugar pine, or western white pine][Any closed-grain hardwood, except that eastern white pine, sugar pine, or western white pine may be used for risers, stringers, and moldings]<Insert species>.
 2. Wood Moisture Content: [5 to 10][8 to 13][4 to 9] percent.
- E. Rough Carriage Stairs:
1. Laminated veneer lumber, made with an exterior-type adhesive complying with ASTM D2559, and with the following allowable design values as determined in accordance with ASTM D5456:
 - a. Extreme Fiber Stress in Bending, Edgewise: [3100 psi][2900 psi][2600 psi][2250 psi]<Insert value> for 12-inch nominal- depth members.
 - b. Modulus of Elasticity, Edgewise: [2,000,000 psi][1,800,000 psi][1,500,000 psi]<Insert value>.
 2. Wood Grade: [Select Structural][No. 1][No. 2], kiln-dried to 15 percent maximum moisture content.

- a. Acceptable Species:
- 1) Hem-fir (north).
 - 2) Southern pine.
 - 3) Douglas fir-larch.
 - 4) Douglas fir-larch (north).
 - 5) Spruce-pine-fir.
 - 6) Hem-fir.
 - 7) Douglas fir-south.
 - 8) Spruce-pine-fir (south).

F. Finishes for Stair Parts:

1. Treads: [Transparent][Opaque].
2. Risers: [Transparent][Opaque].
3. Stringers: [Transparent][Opaque].
4. Balusters: [Transparent][Opaque].
5. Handrails: [Transparent][Opaque].
6. Scotia, Cove, and Other Moldings: [Transparent][Opaque].

G. Handrail/Bumper Rail Brackets: Pairs of extruded-aluminum channels: one for fastening to back of rail and one for fastening to face of wall, assembled in overlapping fashion and fastened together at top and bottom with self-tapping screws. Size to provide **1-1/2-inch** clearance between handrail and wall.

H. Fire-Retardant-Treated Wood Materials: Where fire-retardant-treated materials are indicated, use materials complying with requirements that are acceptable to authorities having jurisdiction and with fire-test-response characteristics specified as determined by testing identical products in accordance with test method indicated by a qualified testing agency.

1. Use treated materials that comply with requirements of the Architectural Woodwork Standards. Do not use materials that are warped, discolored, or otherwise defective.
2. Use fire-retardant-treatment formulations that do not bleed through or otherwise adversely affect finishes. Do not use colorants to distinguish treated materials from untreated materials.
3. Identify fire-retardant-treated materials with appropriate classification marking of qualified testing agency in the form of removable paper label or imprint on surfaces that will be concealed from view after installation.

I. Fire-Retardant-Treated Lumber and Plywood: Products with a flame-spread index of 25 or less when tested in accordance with ASTM E84, with no evidence of significant progressive combustion when the test is extended an additional 20 minutes, and with the flame front not extending more than **10.5 feet** beyond the centerline of the burners at any time during the test.

1. Kiln-dry lumber and plywood after treatment to a maximum moisture content of 19 and 15 percent, respectively.
2. For items indicated to receive a stained, transparent, or natural finish, use

- organic resin chemical formulation.
3. Mill lumber after treatment within limits set for wood removal that do not affect listed fire-test-response characteristics, using a woodworking shop certified by testing and inspecting agency.
 4. Mill lumber before treatment, and implement procedures during treatment and drying processes that prevent lumber from warping and developing discolorations from drying sticks or other causes, marring, and other defects affecting appearance of treated woodwork.

2.5 MISCELLANEOUS MATERIALS

- A. Furring, Blocking, Shims, and Nailers: Softwood or hardwood lumber Fire-retardant-treated softwood lumber, kiln-dried to less than 15 percent moisture content.
 1. Preservative Treatment: Provide softwood lumber treated by pressure process, AWPA U1; Use Category UC3b.
 - a. Provide where in contact with concrete or masonry.
 - b. Kiln-dry lumber after treatment to a maximum moisture content of 19 percent.
 - c. Preservative Chemicals: Acceptable to authorities having jurisdiction and containing no arsenic or chromium.
 - d. Mark lumber with treatment quality mark of an inspection agency approved by the American Lumber Standards Committee's (ALSC) Board of Review.
 2. Fire-Retardant Treatment: Complying with requirements; provide as required Per Drawings.
- B. Provide self-drilling screws for metal-framing supports, as recommended by metal-framing manufacturer.
- C. Anchors: Select material, type, size, and finish required for each substrate for secure anchorage.
 1. Provide metal expansion sleeves or expansion bolts for post-installed anchors.
 2. Use nonferrous-metal or hot-dip galvanized anchors and inserts at inside face of exterior walls and at floors.
- D. Installation Adhesive: Product recommended by fabricator for each substrate for secure anchorage.

2.6 FABRICATION

- A. Sand fire-retardant-treated wood lightly to remove raised grain on exposed surfaces before fabrication.
- B. Fabricate interior architectural woodwork to dimensions, profiles, and details indicated.
 1. Ease edges to radius indicated for the following:

- a. Edges of Solid-Wood (Lumber) Members: **1/16 inch** unless otherwise indicated.
 - b. Edges of Rails and Similar Members More Than 3/4 Inch (19 mm) Thick: **1/8 inch.**
- C. Complete fabrication, including assembly, to maximum extent possible before shipment to Project site.
1. Disassemble components only as necessary for shipment and installation.
 2. Where necessary for fitting at site, provide allowance for scribing, trimming, and fitting.
 3. Notify Architect seven days in advance of the dates and times interior architectural woodwork fabrication will be complete.

2.7 SHOP PRIMING

- A. Preparations for Finishing: Comply with the Architectural Woodwork Standards for sanding, filling countersunk fasteners, sealing concealed surfaces, and similar preparations for finishing interior architectural woodwork, as applicable to each unit of work.
- B. Interior Architectural Woodwork for Opaque Finish: Shop prime with one coat of wood primer as specified in Section 099123 "Interior Painting."
1. Backpriming: Apply one coat of primer, compatible with finish coats, to concealed surfaces of woodwork. Apply two coats to surfaces installed in contact with concrete or masonry and to end-grain surfaces.
- C. Interior Architectural Woodwork for Transparent Finish: Shop-seal concealed surfaces with required pretreatments and first coat of finish as specified in Section 099300 "Staining and Transparent Finishing."
1. Backpriming: Apply one coat of sealer, compatible with finish coats, to concealed surfaces of woodwork. Apply two coats to surfaces installed in contact with concrete or masonry and to end-grain surfaces.

2.8 SHOP FINISHING

- A. Finish interior architectural woodwork with transparent finish at fabrication shop. Defer only final touchup, cleaning, and polishing until after installation.
- B. Preparation for Finishing: Comply with Architectural Woodwork Standards, Section 5 for sanding, filling countersunk fasteners, sealing concealed surfaces, and similar preparations for finishing interior architectural woodwork, as applicable to each unit of work.
1. Backpriming: Apply one coat of sealer or primer, compatible with finish coats, to concealed surfaces of interior architectural woodwork. Apply two coats to end-grain surfaces.

C. Transparent Finish:

1. Architectural Woodwork Standards Grade: Custom.
2. Finish System:
 - a. 12: Polyurethane, Water Based.
3. Wash Coat for Closed-Grain Woods: Apply wash-coat sealer to woodwork made from closed-grain wood before staining and finishing.
4. Staining: Match approved sample for color.
5. Open Finish for Open-Grain Woods: Do not apply filler to open-grain woods.
6. Filled Finish for Open-Grain Woods: After staining, apply wash-coat sealer and allow to dry. Apply paste wood filler and wipe off excess. Tint filler to match stained wood.
7. Sheen: Coordinate with Finish Schedule.

D. Opaque Finish:

1. Architectural Woodworking Standards Grade: Custom.
2. Finish System:
 - a. 4: Latex Acrylic, Water Based.
3. Color: See Finish Schedule.
4. Sheen: See Finish Schedule.

PART 3 - EXECUTION

3.1 PREPARATION

- A. Before installation, condition interior architectural woodwork to humidity conditions in installation areas for not less than 72 hours prior to beginning of installation.
- B. Before installing interior architectural woodwork, examine shop-fabricated work for completion and complete work as required, including removal of packing and backpriming of concealed surfaces.

3.2 INSTALLATION

- A. Grade: Install interior architectural woodwork to comply with same grade as item to be installed.
- B. Assemble interior architectural woodwork and complete fabrication at Project site to the extent that it was not completed during shop fabrication.
- C. Install interior architectural woodwork level, plumb, true in line, and without distortion.
 1. Shim as required with concealed shims.

2. Install level and plumb to a tolerance of **1/8 inch in 96 inches**.
- D. Scribe and cut interior architectural woodwork to fit adjoining work, refinish cut surfaces, and repair damaged finish at cuts.
 - E. Preservative-Treated Wood: Where cut or drilled in field, treat cut ends and drilled holes in accordance with AWPA M4.
 - F. Fire-Retardant-Treated Wood: Install fire-retardant-treated wood to comply with chemical treatment manufacturer's written instructions, including those for adhesives used to install woodwork.
 - G. Anchor interior architectural woodwork to anchors or blocking built in or directly attached to substrates.
 1. Secure with countersunk, concealed fasteners and blind nailing.
 2. Use fine finishing nails or finishing screws for exposed fastening, countersunk and filled flush with interior architectural woodwork.
 3. For shop-finished items, use filler matching finish of items being installed.
 - H. Standing and Running Trim:
 1. Install with minimum number of joints possible, using full-length pieces (from maximum length of lumber available) to greatest extent possible.
 2. Do not use pieces less than **96 inches** long, except where shorter single-length pieces are necessary.
 3. Scarf running joints and stagger in adjacent and related members.
 4. Fill gaps, if any, between top of base and wall with plastic wood filler; sand smooth; and finish same as wood base if finished.
 5. Install standing and running trim with no more variation from a straight line than **1/8 inch in 96 inches**.
 - I. Railings:
 1. Install rails with no more than **1/8 inch in 96-inch** variation from a straight line.
 2. Stair Rails: Glue and dowel or pin balusters to treads and railings, and railings to newel posts.
 - a. Secure with countersunk, concealed fasteners and blind nailing.
 - b. Use fine finishing nails or finishing screws for exposed fastening, countersunk and filled flush with wood surface.
 3. Wall Rails: Support rails on wall brackets securely fastened to wall framing.

3.3 FIELD QUALITY CONTROL

- A. Inspections: Provide inspection of installed Work through AWI's Quality Certification Program certifying that woodwork, including installation, complies with requirements of the Architectural Woodwork Standards for the specified grade.

1. Inspection entity is to prepare and submit report of inspection.

3.4 REPAIR

- A. Repair damaged and defective interior architectural woodwork, where possible, to eliminate functional and visual defects and to result in interior architectural woodwork being in compliance with requirements of Architectural Woodwork Standards for the specified grade.
- B. Where not possible to repair, replace defective woodwork.
- C. Shop Finish: Touch up finishing work specified in this Section after installation of interior architectural woodwork.
 1. Fill nail holes with matching filler where exposed.
 2. Apply specified finish coats, including stains and paste fillers if any, to exposed surfaces where only sealer/prime coats are shop applied.
- D. Field Finish: See Section 099123 "Interior Painting" and Section 099300 "Staining and Transparent Finishing" for final finishing of installed interior architectural woodwork not indicated to be shop finished.

3.5 CLEANING

- A. Clean interior architectural woodwork on exposed and semiexposed surfaces.

END OF SECTION 064023

SECTION 064100 - ARCHITECTURAL WOOD CASEWORK

PART 1 - GENERAL

1.1 SUMMARY

A. Section Includes:

1. Plastic-laminate-clad casework.
2. Wood materials.
3. Casework hardware.
4. Shop finishing.

B. Related Requirements:

1. Section 061000 "Rough Carpentry" for wood furring, blocking, shims, and hanging strips required for installing cabinets that are concealed within other construction before cabinet installation.
2. Section 092216 "Non-Structural Metal Framing" for standard, interior non-load-bearing, metal-stud-framing required for anchoring cabinets.
3. Section 123623.13 "Plastic-Laminate-Clad Countertops." Section 123661 "Simulated Stone Countertops."

1.2 COORDINATION

- A. Coordinate sizes and locations of framing, blocking, furring, reinforcements, and other related units of Work specified in other Sections to support loads imposed by installed and fully loaded cabinets.

1.3 PREINSTALLATION MEETINGS

- A. Preinstallation Conference: Conduct conference at Project site.

1. Review locations and method of attachment of backing required for casework installation.

1.4 ACTION SUBMITTALS

- A. Product Data: For each type of product.

1. Include panel material description and finish.
2. Include accessories.
3. Include hardware.
4. Include shop finishing.

B. Shop Drawings:

1. Plans, elevations, sections, and attachment details.
 - a. Show large-scale details.
 - b. Show locations and sizes of furring, blocking, and hanging strips, including concealed blocking and reinforcement specified in other Sections.
 - c. Show locations and sizes of cutouts and holes for items installed in architectural cabinets.
2. Apply AWI's Quality Certification Program (hereafter AWI QCP) label to Shop Drawings.

C. Samples for Verification: Provide a minimum of three samples showing the full range of color and/or grain to be expected in the finished work, for the following.

1. Veneer Panel for Transparent Finish: **8 by 8 inches** by **1/4 inch**, representative of and selected from flitches to be used for transparent-finished casework.
2. Lumber and Panel Products with Shop-Applied Opaque Finish: Not less than **8 inches** long by **3/4 inches** thick, and as wide as practical, for each species and cut for lumber and **8 by 10 inches** for panels, for each finish system and color.
 - a. Finish entire exposed surface.
3. Plastic Laminates: **8 by 8 inches**, for each type, color, pattern, and surface finish required.
 - a. Provide one Sample applied to core material with specified edge material applied to one edge.
4. Exposed Cabinet Hardware and Accessories: One full-size unit for each type and finish.

1.5 INFORMATIONAL SUBMITTALS

A. Certification Reports:

1. Provide labels and certificates from AWI QCP indicating woodwork and installation comply with requirements of aesthetic grade and duty level specified.
 - a. Register the Work of this Section with AWI's Quality Certification Program.

B. Product Certificates: For each type of product.

1. Composite wood products.
2. Thermally fused laminate (TFL) panels.
3. Glass.
4. Adhesives.

C. Field quality control reports.

1.6 CLOSEOUT SUBMITTALS

- A. Quality Standard Compliance Certificates: AWI QCP Certificate.

1.7 QUALITY ASSURANCE

- A. Manufacturer Qualifications: Employs skilled workers who custom fabricate products similar to those required for this Project and whose products have a record of successful in-service performance.

- 1. Manufacturer's Certification: Licensed participant in AWI's Quality Certification Program.

- B. Installer Qualifications: Manufacturer of products.

1.8 DELIVERY, STORAGE, AND HANDLING

- A. Do not deliver cabinets until painting and similar finish operations that might damage architectural cabinets have been completed in installation areas. Store cabinets in installation areas or in areas where environmental conditions comply with requirements specified in "Field Conditions" Article.

1.9 FIELD CONDITIONS

- A. Environmental Limitations with Humidity Control: Do not deliver or install cabinets until building is enclosed, wet-work is complete, and HVAC system is operating and maintaining temperature between **60 and 90 deg F** and relative humidity between 30 and 55 percent during the remainder of the construction period.

- B. Field Measurements: Where cabinets are indicated to fit to other construction, verify dimensions of other construction by field measurements before fabrication, and indicate measurements on Shop Drawings. Coordinate fabrication schedule with construction progress to avoid delaying the Work.

- 1. Locate concealed framing, blocking, and reinforcements that support cabinets by field measurements before being enclosed/concealed by construction, and indicate measurements on Shop Drawings.

- C. Established Dimensions: Where cabinets are indicated to fit to other construction, establish dimensions for areas where cabinets are to fit. Provide allowance for trimming at site, and coordinate construction to ensure that actual dimensions correspond to established dimensions.

PART 2 - PRODUCTS

2.1 PERFORMANCE REQUIREMENTS

- A. Unless otherwise indicated, comply with ANSI/AWI 0641 for duty level and grade of architectural cabinets indicated for construction, finishes, installation, and other requirements.
 - 1. Provide labels and certificates from AWI QCP indicating that woodwork complies with requirements of aesthetic grade and duty level specified.

2.2 Cabinet Hardware

- A. Manufacturers: Subject to compliance with requirements, provide products by the following:
 - 1. Hardware Resources

2.3 PLASTIC-LAMINATE-CLAD CASEWORK

- A. Architectural Woodwork Institute (AWI) Standard:
 - 1. Structural Performance Duty Level: 2.
 - 2. Aesthetic Performance Grade: Custom.
- B. Casework Construction Type: Frameless.
- C. Door and Drawer-Front:
 - 1. Design: Flush panel.
 - 2. Style: Flush overlay.
- D. High-Pressure Decorative Laminate (HDPL): ISO 4586-3, grades as indicated or, if not indicated, as required by quality standard.
 - 1. Basis-of-Design Product: Subject to compliance with requirements, provide Wilsonart; Style Per Finish Schedule or comparable product by one of the following:
 - a. ABET Inc.
 - b. Formica Corporation
 - c. Laminart LLC
 - d. Pionite; a Panolam Industries International, Inc. brand
- E. Colors, Patterns, and Finishes: Provide materials and products that result in colors and textures of exposed laminate surfaces complying with the following requirements:
 - 1. As indicated by laminate manufacturer's designations.

F. Exposed Exterior Surfaces:

1. Plastic-Laminate Grade: VGS.
2. Pattern Direction: As indicated on Drawings.
3. Edgebanding: High-pressure decorative laminate (HDPL).

G. Exposed Interior Surfaces: High-pressure decorative laminate (HDPL) the same color and pattern as exposed exterior surfaces.

1. Edgebanding: High-pressure decorative laminate (HDPL).

H. Semiexposed Surfaces:

1. Surfaces Other Than Drawer Bodies: High-pressure decorative laminate (HDPL) cabinet liner Grade CLS, ISO 4586-3. White melamine interior.
2. Drawer Sides and Backs: Seven- or nine-ply plywood with no internal voids.
3. Concealed Backs of Panels with Exposed Plastic-Laminate Surfaces: High-pressure decorative laminate (HDPL), ISO 4583-3, grade to match exposed surface. Option to provide Melamine. Contractor to submit sample to Architect for selection.
4. Drawer Bottoms: Thermally fused laminate (TFL) panels.
5. Shelves: Adjustable.
 - a. Loading Capacity: 40 lb/sq. ft.
6. Edgebanding: High-pressure decorative laminate (HDPL).

2.4 WOOD MATERIALS

A. Wood Products: Provide materials that comply with requirements of referenced quality standard for each type of architectural cabinet and quality grade specified unless otherwise indicated.

1. Do not use plain-sawn softwood lumber with exposed, flat surfaces more than **3 inches** wide.
2. Wood Moisture Content:
 - a. Non-Climate-Controlled Environments: 9 to 15 percent.
 - b. Climate-Controlled Environments: 6 to 10 percent.

B. Composite Wood Products: Provide materials that comply with requirements of referenced quality standard for each type of architectural cabinet and quality grade specified unless otherwise indicated.

1. Medium-Density Fiberboard (MDF): ANSI A208.2, Grade 130.
2. Particleboard (Medium Density): ANSI A208.1, Grade M-2.
3. Softwood Plywood: DOC PS 1, medium-density overlay.
4. Veneer-Faced Panel Products (Hardwood Plywood): HPVA HP-1.
5. Thermally Fused Laminate (TFL) Panels: Particleboard or MDF finished with thermally fused, melamine-impregnated decorative paper and complying with

requirements of AWI 300.

2.5 CASEWORK HARDWARE

A. Hinges:

1. Frameless Concealed Hinges (European Type): ANSI/BHMA A156.9, B01602, degrees of opening, self-closing.
 - a. BHMA A156.9 Type B01602. Provide two hinges for doors less than 48 inches (1220 mm) high, and provide three hinges for doors more than 48 inches (1220 mm) high.

B. Pulls and Knobs:

1. Back-Mounted Pulls: ANSI/BHMA A156.9, B02011.
2. Back-Mounted Knobs: ANSI/BHMA A156.9, B02041.
3. Per Finish Schedule

C. Catches and Latches:

1. Roller Catches, Double Rollers: ANSI/BHMA A156.9, B03072.
 - a. Zinc-plated, nylon-roller spring catch. Provide two catches on door more than 48 inches high.

D. Shelf Rests and Standards:

1. Adjustable Shelf Standards and Supports: ANSI/BHMA A156.9, B04071; with shelf rests, B04081.
2. Shelf Rests: ANSI/BHMA A156.9, B04013; metal.

E. Drawer Slides: ANSI/BHMA A156.9.

1. Standard Duty (Grade 1 and Grade 2): Side mount.
 - a. Box drawer slides: Grade 1 for drawings not more than 6 inches (150 mm) high and 24 inches wide.
2. Heavy-Duty (Grade 1HD-100 and Grade 1HD-200): Side mount.
 - a. Type: Full extension.
 - b. Material: Zinc-plated ball-bearing slides.
 - c. Motion Feature: self-closing mechanism.
3. Drawer Types:
 - a. Pencil drawers not more than **3 inches** high and not more than **24 inches** wide provide **50 lb** load capacity.
 - b. General-purpose drawers more than **3 inches** high, but not more than

tolerances, location of reinforcements, and other conditions affecting performance of the Work.

1. Confirm location and adequacy of blocking and supports required for installation.
2. Verify size and locations of cutouts for appliances, special equipment, sinks, plumbing, and other items to be mounted in or adjacent to casework.

B. Proceed with installation only after unsatisfactory conditions have been corrected.

3.2 PREPARATION

A. Before installation, condition cabinets to humidity conditions in installation areas for not less than 72 hours.

3.3 INSTALLATION OF CASEWORK

A. Install casework to comply with requirements of the structural and aesthetic performance specified.

B. Assemble cabinets and complete fabrication at Project site to extent that it was not completed in the shop.

C. Install cabinets level, plumb, and true in line to a tolerance of **1/8 inch in 96 inches** using concealed shims.

1. Scribe and cut cabinets to fit adjoining work, refinish cut surfaces, and repair damaged finish at cuts.
2. Install cabinets without distortion so doors and drawers fit openings and are accurately aligned. Adjust hardware to center doors and drawers in openings and to provide unencumbered operation. Complete installation of hardware and accessory items as indicated.
3. Maintain veneer sequence matching of cabinets with transparent finish.

D. Anchor cabinets in accordance with AWI requirements or tested method to anchors or blocking built in or directly attached to framing or substrates.

E. Shop Finishes: Touch up finishing after installation of architectural cabinets. Fill nail holes with matching filler.

1. Apply specified finish coats, including stains and paste fillers if any, to exposed surfaces where only sealer/prime coats are shop applied.
 - a. Use filler matching finish of items being installed.

3.4 FIELD QUALITY CONTROL

A. Inspections: Provide inspection of installed Work through AWI's Quality Certification Program certifying that casework, including installation, complies with requirements of

ANSI/AWI 0620 for the specified grade.

1. AWI QCP Inspector to prepare and submit inspection report.

3.5 ADJUSTING AND CLEANING

- A. Repair damaged and defective cabinets, where possible, to eliminate functional and visual defects. Where impossible to repair, replace architectural cabinets. Adjust joinery for uniform appearance.
- B. Clean, lubricate, and adjust hardware and other moving parts to function smoothly.
- C. Clean cabinets on exposed and semiexposed surfaces. Touch up finishes to restore damaged or soiled areas.

END OF SECTION 064100

SECTION 066400 - PLASTIC PANELING

PART 1 - GENERAL

1.1 SUMMARY

A. Section Includes:

1. Plastic sheet paneling.

B. Related Requirements:

1. Section 061000 "Rough Carpentry" for wood furring for installing plastic paneling.
2. Section 064219 "Plastic-Laminate-Faced Wood Paneling."
3. Section 102600 "Wall and Door Protection" for corner guards installed over plastic paneling.

1.2 ACTION SUBMITTALS

A. Product Data: For each type of product.

B. Sustainable Design Submittals:

C. Samples: For plastic paneling, in manufacturer's standard sizes.

1.3 QUALITY ASSURANCE

A. Testing Agency: Acceptable to authorities having jurisdiction.

PART 2 - PRODUCTS

2.1 PLASTIC SHEET PANELING

A. Glass-Fiber-Reinforced Plastic Paneling (FRP-1/WP-2): Gelcoat-finished, glass-fiber-reinforced plastic panels complying with ASTM D5319. Panels are to be USDA accepted for incidental food contact.

1. Basis-of-Design Product: Subject to compliance with requirements, provide PANOLAM; FRP or Approved Equivalent by one of the following:
 - a. Crane Composites, Inc.
 - b. Marlite, Inc.
 - c. Nudo; a Verzatec Group Company
 - d. Parkland Plastics Inc.; a Patrick Industries Inc. Company

2. Surface-Burning Characteristics: As follows when tested by a qualified testing agency in accordance with ASTM E84. Identify products with appropriate markings of applicable testing agency.
 - a. Flame-Spread Index: 25 or less.
 - b. Smoke-Developed Index: 450 or less.
3. Nominal Thickness: Not less than 0.09 inch.
4. Surface Finish: Embossed.
5. Color: White.

2.2 ACCESSORIES

- A. Trim Accessories: Manufacturer's standard one-piece vinyl extrusions designed to retain and cover edges of panels. Provide division bars, inside corners, outside corners, and caps as needed to conceal edges.
 1. Color: Match panels.
 2. Confirm Trim Accessories with Architect.
- B. Exposed Fasteners: Nylon drive rivets recommended by panel manufacturer.
- C. Concealed Mounting Splines: Continuous, H-shaped aluminum extrusions designed to fit into grooves routed in edges of factory-laminated panels and to be fastened to substrate.
- D. Adhesive: As recommended by plastic paneling manufacturer.
- E. Sealant: Mildew-resistant, single-component, neutral-curing silicone sealant recommended by plastic paneling manufacturer and complying with requirements in Section 079200 "Joint Sealants."

PART 3 - EXECUTION

3.1 INSTALLATION

- A. Install plastic paneling according to manufacturer's written instructions.
- B. Install panels in a full spread of adhesive.
- C. Install trim accessories with adhesive. Do not fasten through panels.
- D. Fill grooves in trim accessories with sealant before installing panels, and bed inside corner trim in a bead of sealant.
- E. Maintain uniform space between panels and wall fixtures. Fill space with sealant.
- F. Remove excess sealant and smears as paneling is installed. Clean with solvent

recommended by sealant manufacturer and then wipe with clean dry cloths until no residue remains.

END OF SECTION 066400

SECTION 072100 - THERMAL INSULATION

PART 1 - GENERAL

1.1 SUMMARY

A. Section Includes:

1. Extruded polystyrene foam-plastic board insulation.
2. Molded (expanded) polystyrene foam-plastic board insulation.
3. Polyisocyanurate foam-plastic board insulation.
4. Glass-fiber blanket insulation.
5. Mineral-wool blanket insulation.
6. Mineral-wool board insulation.

B. Related Requirements:

1. Section 061600 "Sheathing" for foam-plastic board sheathing installed directly over wood or steel framing.
2. Section 072119 "Foamed-in-Place Insulation" for spray-applied polyurethane foam insulation.
3. Section 075423 "Thermoplastic-Polyolefin (TPO) Roofing" for insulation specified as part of roofing construction.
4. Section 092900 "Gypsum Board" for sound attenuation blanket used as acoustic insulation.

1.2 ACTION SUBMITTALS

- ##### A. Product Data: For each type of product.

1.3 INFORMATIONAL SUBMITTALS

- ##### A. Installer's Certification: Listing type, manufacturer, and R-value of insulation installed in each element of the building thermal envelope.

1. For blown-in or sprayed fiberglass and cellulosic-fiber loose-fill insulation, indicate initial installed thickness, settled thickness, settled R-value, installed density, coverage area, and number of bags installed.
2. Sign, date, and post the certification in a conspicuous location on Project site.

PART 2 - PRODUCTS

2.1 PERFORMANCE REQUIREMENTS

- A. Surface-Burning Characteristics: Maximum flame-spread and smoke-developed indexes less than Class A, 25 and 450 when tested in accordance with ASTM E84.
- B. Fire-Resistance Ratings: Comply with ASTM E119 or UL 263; testing by a qualified testing agency. Identify products with appropriate markings of applicable testing agency.
 - 1. Indicate design designations from UL's "Fire Resistance Directory" or from listings of another qualified testing agency.
- C. Fire Propagation Characteristics: Passes NFPA 285 testing as part of an approved assembly.
- D. Labeling: Provide identification of mark indicating R-value of each piece of insulation **12 inches** and wider in width.
- E. Thermal-Resistance Value (R-Value): R-value as indicated on Drawings in accordance with ASTM C518.

2.2 EXTRUDED POLYSTYRENE FOAM-PLASTIC BOARD INSULATION (XPS)

- A. Extruded Polystyrene Board Insulation, Type X: ASTM C578, Type X, **15 psi** minimum compressive strength; unfaced.
 - 1. Manufacturers: Subject to compliance with requirements, available manufacturers offering products that may be incorporated into the Work include, but are not limited to, the following:
 - a. DiversiFoam Products
 - b. DuPont de Nemours, Inc.
 - c. MBCI; Cornerstone Building Brands
 - d. Owens Corning
 - e. The Dow Chemical Company

2.3 POLYISOCYANURATE FOAM-PLASTIC BOARD INSULATION

- A. Polyisocyanurate Board Insulation, Foil Faced: ASTM C1289, foil faced, Type I, Class 1 or 2.
 - 1. Basis-of-Design Product: Subject to compliance with requirements, provide DuPont de Nemours, Inc.; Thermax (ci) Exterior Insulation or comparable product by one of the following:
 - a. Atlas Molded Products, a division of Atlas Roofing Corporation

- b. Atlas Polyiso Roof and Wall Insulation
- c. Carlisle Coatings & Waterproofing Inc
- d. Elevate; Amrize Building Envelope LLC
- e. Hunter Panels; a Carlisle company
- f. Johns Manville; a Berkshire Hathaway company
- g. Rmax, A Business Unit of Sika Corporation

2.4 GLASS-FIBER BLANKET INSULATION

- A. Glass-Fiber Blanket Insulation, Unfaced: ASTM C665, Type I; passing ASTM E136 for combustion characteristics.

2.5 MINERAL-WOOL BLANKET INSULATION

- A. Mineral-Wool Blanket Insulation, Unfaced: ASTM C665, Type I (blankets without membrane facing); consisting of fibers; complying with ASTM E136 for combustion characteristics.

2.6 MINERAL-WOOL BOARD INSULATION

- A. Mineral-Wool Board Insulation, Type II, Faced: ASTM C612, Type II; faced on one side with foil-scrim or foil-scrim-polyethylene vapor retarder.
 - 1. Manufacturers: Subject to compliance with requirements, available manufacturers offering products that may be incorporated into the Work include, but are not limited to, the following:
 - a. Johns Manville; a Berkshire Hathaway company
 - b. Owens Corning
 - c. Specialty Products & Insulation (SPI)

2.7 ACCESSORIES

- 1. Glass-Fiber Insulation: ASTM C764, Type II, loose fill; with maximum flame-spread and smoke-developed indexes of 5, per ASTM E84.
 - 2. Spray Polyurethane Foam Insulation: ASTM C1029, Type II, closed cell, with maximum flame-spread and smoke-developed indexes of 75 and 450, respectively, per ASTM E84.
- B. Miscellaneous Application Accessories:
 - 1. Adhesive for Bonding Insulation: Product compatible with insulation and air and water barrier materials, and with demonstrated capability to bond insulation securely to substrates without damaging insulation and substrates.
 - 2. Crack Sealer: Closed-cell insulating foam in aerosol dispenser recommended in writing by insulation manufacturer for filling gaps in board insulation.
 - 3. Curtain-Wall Insulation Clips: Z-shaped galvanized steel as recommended in

- writing by insulation manufacturer.
4. Eave Ventilation Troughs: Preformed, rigid fiberboard or plastic sheets designed and sized to fit between roof framing members and to provide ventilation between insulated attic spaces and vented eaves.
 5. Detailing Foam Insulation for Voids: Urethane foam complying with AAMA 812, low expansion pressure suitable for filling insulation gaps and voids adjacent to openings to protect against water, air, and sound intrusion.
 6. Tapes for Reflective Insulation and Barriers:
 - a. Aluminum-foil tape for repairs or splicing material.
 - b. Double-sided tape for adhering to metal framing or overlapping material.
 - c. Reinforced-foil tape for sealing tears or cuts in sheet vapor barrier.
 7. Clip-and-Pin Components:
 - a. Beam/Bar Joist Clips: For beams, bar joists, and Z-type purlins.
 - b. C-Purlin Clips: For C-type purlins.
 - c. Angle Clips: For sidewalks and floors.
 - d. Tube Clips: For wood beams and metal tubular framing.
 - e. Locking Washers: Aluminum; white to match reflective bubble insulation facing colors.
 8. Wire Mesh Lath Support for Insulation: ASTM C1032.
 - a. Material: Woven wire lath **1-1/2-inch** hexagonal-shaped mesh with minimum **0.0510-inch-** diameter, galvanized-steel wire.

PART 3 - EXECUTION

3.1 INSTALLATION, GENERAL

- A. Comply with insulation manufacturer's written instructions applicable to products, applications and applicable codes.
- B. Install insulation that is undamaged, dry, and unsoiled and that has not been left exposed to ice, rain, or snow at any time.
- C. Install insulation with manufacturer's R-value label exposed after insulation is installed.
- D. Extend insulation to envelop entire area to be insulated. Fit tightly around obstructions and fill voids with insulation. Remove projections that interfere with placement.
- E. Provide sizes to fit applications and selected from manufacturer's standard thicknesses, widths, and lengths. Apply single layer of insulation units unless multiple layers are otherwise shown or required to make up total thickness or to achieve R-value.

3.2 INSTALLATION OF CAVITY-WALL INSULATION

- A. Foam-Plastic Board Insulation: Install pads of adhesive spaced approximately **24 inches** o.c. both ways on inside face and as recommended in writing by manufacturer.
1. Fit courses of insulation between obstructions, with edges butted tightly in both directions, and with faces flush.
 2. Press units firmly against inside substrates.
 3. Supplement adhesive attachment of insulation by securing boards with two-piece wall ties designed for this purpose and specified in Section 042000 "Unit Masonry."
- B. Mineral-Wool Board Insulation: Install insulation fasteners **4 inches** from each corner of board insulation, at center of board, and as recommended by manufacturer.
1. Fit courses of insulation between masonry wall ties and other obstructions, with edges butted tightly in both directions, and with faces flush.
 2. Press units firmly against inside substrates.

3.3 INSTALLATION OF INSULATION IN FRAMED CONSTRUCTION

- A. Blanket Insulation: Install in cavities formed by framing members in accordance with the following requirements:
1. Use insulation widths and lengths that fill the cavities formed by framing members. If more than one length is required to fill the cavities, provide lengths that will produce a snug fit between ends.
 2. Place insulation in cavities formed by framing members to produce a friction fit between edges of insulation and adjoining framing members.
 3. Maintain **3-inch** clearance of insulation around recessed lighting fixtures not rated for or protected from contact with insulation.
 4. Attics: Install eave ventilation troughs between roof framing members in insulated attic spaces at vented eaves.
 5. For metal-framed wall cavities where cavity heights exceed **96 inches**, support unfaced blankets mechanically and support faced blankets by taping flanges of insulation to flanges of metal studs.
 6. Where glass-fiber blankets are indicated for sound attenuation above ceilings, install unfaced blanket insulation over ceiling area in thickness indicated. Where partitions occur, extend insulation up either side of partition.
 7. For wood-framed construction, install blankets in accordance with ASTM C1320 and as follows:
 - a. With faced blankets having stapling flanges, lap blanket flange over flange of adjacent blanket to maintain continuity of vapor retarder once finish material is installed over it.
- B. Miscellaneous Voids: Install insulation in miscellaneous voids and cavity spaces where required to prevent gaps in insulation using the following materials:

1. Glass-Fiber Insulation: Compact to approximately 40 percent of normal maximum volume equaling a density of approximately **2.5 lb/cu. ft.**
2. Detailing Foam Insulation for Voids: Apply in accordance with manufacturer's written instructions.

3.4 INSTALLATION OF BOARD INSULATION

- A. Install board insulation in accordance with manufacturer's written instructions per project applications and conditions.

END OF SECTION 072100

SECTION 072119 - FOAMED-IN-PLACE INSULATION

PART 1 - GENERAL

1.1 SUMMARY

A. Section Includes:

1. Closed-cell spray polyurethane foam insulation.

B. Related Requirements:

1. Section 072100 "Thermal Insulation" for foam-plastic board insulation.

1.2 ACTION SUBMITTALS

- A. Product Data: For each type of product.

1.3 INFORMATIONAL SUBMITTALS

- A. Field quality control reports.
- B. Qualification Statements: For Installer.

1.4 QUALITY ASSURANCE

- A. Installer Qualifications: An authorized representative who is trained and approved by manufacturer.

PART 2 - PRODUCTS

2.1 CLOSED-CELL SPRAY POLYURETHANE FOAM INSULATION

- A. Closed-Cell Spray Polyurethane Foam: ASTM C1029.

1. Manufacturers: Subject to compliance with requirements, available manufacturers offering products that may be incorporated into the Work include, but are not limited to, the following:
 - a. AMBIT Polyurethane
 - b. Carlisle Spray Foam Insulation
 - c. Enverge, Amrize Building Envelope LLC
 - d. Gaco; Amrize Building Envelope LLC

- e. Henry, a Carlisle Company (formerly Henry Company and Carlisle Coatings & Waterproofing Inc. brands)
 - f. Huntsman Building Solutions
 - g. Johns Manville; a Berkshire Hathaway company
 - h. NCFI Polyurethanes; a division of Barnhardt Manufacturing Company
 - i. Quadrant Performance Materials
 - j. SWD Urethane Company
 - k. Thermoseal USA
 - l. Volatile Free, Inc.
2. Type and Minimum Compressive Strength:
 - a. Type II, minimum density of **1.5 lb/cu. ft.** and minimum aged R-value at **1-inch** thickness of **6.2 deg F x h x sq. ft./Btu at 75 deg F.**
 3. Surface-Burning Characteristics: Comply with ASTM E84; testing by a qualified testing agency. Identify products with appropriate markings of applicable testing agency.
 - a. Flame-Spread Index: 25 or less.
 - b. Smoke-Developed Index: 450 or less.
 - c. Fire-Propagation Characteristics: Passes NFPA 285 and NFPA 276 testing as part of an approved assembly.
 4. Fire-Safety Barriers: Approved assembly as thermal barrier with accessory components.

PART 3 - EXECUTION

3.1 INSTALLATION OF FOAMED-IN-PLACE INSULATION

- A. Comply with insulation manufacturer's written instructions applicable to products and applications.
- B. Spray insulation to envelop entire area to be insulated and fill voids.
- C. Apply in multiple passes to not exceed maximum thicknesses recommended by manufacturer. Do not spray into rising foam.
- D. Framed Construction: Install into cavities formed by framing members to achieve thickness indicated on Drawings.
- E. Cavity Walls: Install into cavities to thickness indicated on Drawings.
- F. Miscellaneous Voids: Apply according to manufacturer's written instructions.
- G. Install thermal barrier material.
 1. Do not cover insulation prior to any required spray foam insulation inspections.

- H. Apply barrier coatings in accordance with manufacturer's written instructions and to comply with requirements for listing and labeling for fire-propagation characteristics and surface-burning characteristics specified.
 - 1. Use equipment and techniques best suited for substrate and type of material applied as recommended by coating manufacturer.
 - 2. Apply coatings to prepared surfaces as soon as practical after preparation and before subsequent surface soiling or deterioration.
 - 3. Apply coatings to produce surface films without cloudiness, spotting, holidays, laps, brush marks, roller tracking, runs, sags, ropiness, or other surface imperfections. Produce sharp lines and color breaks.

3.2 FIELD QUALITY CONTROL

- A. Manufacturer's Field Service: Engage a factory-authorized service representative to test and inspect spray foam insulation installation, including accessories. Report results in writing.

END OF SECTION 072119

SECTION 072715 - NONBITUMINOUS SELF-ADHERING SHEET AIR BARRIERS

PART 1 - GENERAL

1.1 SUMMARY

- A. Section Includes: Self-adhering air barrier.
 - 1. Vapor-permeable nonbituminous sheet.
- B. Related Requirements:
 - 1. Section 061600 "Sheathing" for wall sheathings and wall sheathing joint-and-penetration treatments.

1.2 DEFINITIONS

- A. Air-Barrier Accessory: A transitional component of the air barrier that provides continuity.
- B. Air-Barrier Assembly: The collection of air-barrier materials and accessories applied to an opaque wall, including joints and junctions to abutting construction, to control air movement through the wall.
- C. Air-Barrier Material: A primary element that provides a continuous barrier to the movement of air.

1.3 ACTION SUBMITTALS

- A. Product Data: Self-adhering air barrier. Include manufacturer's written instructions for evaluating, preparing, and treating each substrate; technical data; and tested physical and performance properties of products.
 - 1. Vapor-permeable nonbituminous sheet.
- B. Shop Drawings: For air-barrier assemblies.
 - 1. Show locations and extent of air-barrier materials, accessories, and assemblies specific to Project conditions.
 - 2. Include details for substrate joints and cracks, counterflashing strips, penetrations, inside and outside corners, terminations, and tie-ins with adjoining construction.
 - 3. Include details of interfaces with other materials that form part of air barrier.

1.4 INFORMATIONAL SUBMITTALS

- A. Qualification Data: For Installer. Include list of ABAA-certified installers and supervisors employed by Installer, who work on Project.
- B. Field quality-control reports.

1.5 QUALITY ASSURANCE

- A. Installer Qualifications: An entity that employs installers and supervisors who are trained and approved by manufacturer.

1.6 DELIVERY, STORAGE, AND HANDLING

- A. Remove and replace liquid materials that cannot be applied within their stated shelf life.
- B. Protect stored materials from direct sunlight.

1.7 FIELD CONDITIONS

- A. Environmental Limitations: Apply air barrier within the range of ambient and substrate temperatures recommended in writing by air-barrier manufacturer.
 - 1. Protect substrates from environmental conditions that affect air-barrier performance.
 - 2. Do not apply air barrier to a damp or wet substrate or during snow, rain, fog, or mist.

PART 2 - PRODUCTS

2.1 SOURCE LIMITATIONS

- A. Obtain primary air-barrier materials and air-barrier accessories from single source from single manufacturer.

2.2 PERFORMANCE REQUIREMENTS

- A. Air-Barrier Performance: Air-barrier assembly and seals with adjacent construction to be capable of performing as a continuous air barrier. Air-barrier assemblies to be capable of accommodating substrate movement and of sealing substrate expansion and control joints, construction material changes, penetrations, and transitions at perimeter conditions without deterioration and air leakage exceeding specified limits.
- B. Air-Barrier Assembly Air Leakage: Maximum **0.04 cfm/sq. ft. of surface area at 1.57 lbf/sq. ft.**, when tested in accordance with ASTM E2357.

2.3 NONBITUMINOUS SHEET AIR BARRIER

- A. Vapor-Permeable Nonbituminous Sheet: Minimum **20-mil-** thick, self-adhering sheet consisting of a breathable carrier film or fabric and an adhesive with release liner on adhesive side and formulated for application with primer that complies with VOC limits.
1. Basis-of-Design Product: Subject to compliance with requirements, provide Henry Company; Blueskin VP160 or Approved Equivalent by one of the following:
 - a. 3M Building and Construction
 - b. Carlisle Coatings & Waterproofing Inc
 - c. Dorken Systems Inc.
 - d. GCP Applied Technologies Inc.
 - e. VaproShield LLC
 - f. W. R. Meadows, Inc
 2. Physical and Performance Properties:
 - a. Air Permeance: Maximum pressure difference perASTM E2178.
- B. Requirement: Provide primers, transition strips, termination strips, joint sealants, counterflashing strips, flashing sheets and metal termination bars, termination mastic, substrate patching materials, adhesives, tapes, foam sealants, lap sealants, and other accessory materials that are recommended in writing by air-barrier manufacturer to produce a complete air-barrier assembly and that are compatible with primary air-barrier material and adjacent construction to which they may seal.
- C. Primer: Liquid [**waterborne**][**solvent-borne**] primer recommended for substrate by air-barrier material manufacturer.
- D. Stainless Steel Sheet: ASTM A240/A240M, Type 304, [**0.0187 inch**][**0.0250 inch**]**<Insert dimension>** thick, and Series 300 stainless steel fasteners.

PART 3 - EXECUTION

3.1 EXAMINATION

- A. Examine substrates, areas, and conditions, with Installer present, for compliance with requirements and other conditions affecting performance of the Work.
1. Verify that substrates are sound and free of oil, grease, dirt, excess mortar, or other contaminants.
 2. Verify that substrates have cured and aged for minimum time recommended in writing by air-barrier manufacturer.
 3. Verify that substrates are visibly dry and free of moisture.
 4. Verify that masonry joints are flush and completely filled with mortar.
- B. Proceed with installation only after unsatisfactory conditions have been corrected.

3.2 SURFACE PREPARATION

- A. Clean, prepare, treat, fill, and seal substrate and joints and cracks in substrate in accordance with manufacturer's written instructions and details. Provide clean, dust-free, and dry substrate for air-barrier application.
- B. Mask off adjoining surfaces not covered by air barrier to prevent spillage and overspray affecting other construction.
- C. Remove grease, oil, bitumen, form-release agents, paints, curing compounds, and other penetrating contaminants or film-forming coatings from concrete.
- D. Remove fins, ridges, mortar, and other projections and fill honeycomb, aggregate pockets, holes, and other voids in concrete with substrate-patching membrane.
- E. Remove excess mortar from masonry ties, shelf angles, and other obstructions.
- F. At changes in substrate plane, apply sealant or termination mastic beads at sharp corners and edges to form a smooth transition from one plane to another.
- G. Cover gaps in substrate plane and form a smooth transition from one substrate plane to another with stainless steel sheet mechanically fastened to structural framing to provide continuous support for air barrier.

3.3 INSTALLATION OF NONBITUMINOUS SHEET AIR BARRIER

- A. Install materials in accordance with air-barrier manufacturer's written instructions and details to form a seal with adjacent construction and ensure continuity of air and water barrier.
 - 1. Unless manufacturer recommends in writing against priming, apply primer to substrates at required rate and allow it to dry.
- B. Prepare, treat, and seal inside and outside corners and vertical and horizontal surfaces at terminations and penetrations with termination mastic.
- C. Apply primer to substrates at required rate and allow it to dry. Limit priming to areas that will be covered by air-barrier sheet on same day. Reprime areas exposed for more than 24 hours.
- D. Apply and firmly adhere air-barrier sheets over area to receive air barrier. Accurately align sheets and maintain uniform **2-1/2-inch-** minimum lap widths and end laps. Overlap and seal seams, and stagger end laps to ensure airtight installation.
 - 1. Apply sheets in a shingled manner to shed water.
 - 2. Roll sheets firmly to enhance adhesion to substrate.
- E. Apply continuous air-barrier sheets over accessory strips bridging substrate cracks, construction, and contraction joints.

- F. Seal top of through-wall flashings to air-barrier sheet with an additional **6-inch-** wide, transition strip.
- G. Seal exposed edges of sheet at seams, cuts, penetrations, and terminations not concealed by metal counterflashings or ending in reglets with termination mastic.
- H. Install air-barrier sheet and accessory materials to form a seal with adjacent construction and to maintain a continuous air barrier.
 - 1. Coordinate air-barrier installation with installation of roofing membrane and base flashing to ensure continuity of air barrier with roofing membrane.
 - 2. Install transition strip on roofing membrane or base flashing so that a minimum of **3 inches** of coverage is achieved over each substrate.
- I. Connect and seal exterior wall air-barrier sheet continuously to roofing-membrane air barrier, concrete below-grade structures, floor-to-floor construction, exterior glazing and window systems, glazed curtain-wall systems, storefront systems, exterior louvers, exterior door framing, and other construction used in exterior wall openings, using accessory materials.
- J. At end of each working day, seal top edge of air-barrier material to substrate with termination mastic.
- K. Apply joint sealants forming part of air-barrier assembly within manufacturer's recommended application temperature ranges. Consult manufacturer when sealant cannot be applied within these temperature ranges.
- L. Wall Openings: Prime concealed, perimeter frame surfaces of windows, curtain walls, storefronts, and doors. Apply transition strip so that a minimum of **3 inches** of coverage is achieved over each substrate. Maintain **3 inches** of contact over firm bearing to perimeter frames, with not less than **1 inch** of full contact.
 - 1. Transition Strip: Roll firmly to enhance adhesion.
 - 2. Preformed Silicone Extrusion: Set in full bed of silicone sealant applied to walls, frame, and air-barrier material.
- M. Fill gaps in perimeter frame surfaces of windows, curtain walls, storefronts, doors, and miscellaneous penetrations of air-barrier material with foam sealant.
- N. Repair punctures, voids, and deficient lapped seams in air barrier. Slit and flatten fishmouths and blisters. Patch with air-barrier sheet extending **6 inches** beyond repaired areas in all directions.
- O. Do not cover air barrier until it has been tested and inspected by testing agency.
- P. Correct deficiencies in or remove air barrier that does not comply with requirements; repair substrates and reapply air-barrier components.

3.4 FIELD QUALITY CONTROL

- A. ABAA Quality Assurance Program: Perform examinations, preparation, installation, testing, and inspections under ABAA's Quality Assurance Program.
- B. Testing Agency: Engage a qualified testing agency to perform tests and inspections.
- C. Inspections: Air-barrier materials, accessories, and installation are subject to inspection for compliance with requirements. Inspections may include the following:
 - 1. Continuity of air-barrier system has been achieved throughout the building envelope with no gaps or holes.
 - 2. Continuous structural support of air-barrier system has been provided.
 - 3. Masonry and concrete surfaces are smooth, clean, and free of cavities, protrusions, and mortar droppings.
 - 4. Site conditions for application temperature and dryness of substrates have been maintained.
 - 5. Maximum exposure time of materials to UV deterioration has not been exceeded.
 - 6. Surfaces have been primed.
 - 7. Laps in sheet materials have complied with the minimum requirements and have been shingled in the correct direction (or mastic applied on exposed edges), with no fishmouths.
 - 8. Termination mastic has been applied on cut edges.
 - 9. Air barrier has been firmly adhered to substrate.
 - 10. Compatible materials have been used.
 - 11. Transitions at changes in direction and structural support at gaps have been provided.
 - 12. Connections between assemblies (air barrier and sealants) have complied with requirements for cleanliness, surface preparation and priming, structural support, integrity, and continuity of seal.
 - 13. All penetrations have been sealed.
- D. Air barriers will be considered defective if they do not pass tests and inspections.
 - 1. Apply additional air-barrier material, in accordance with manufacturer's written instructions, where inspection results indicate insufficient thickness.
 - 2. Remove and replace deficient air-barrier components for retesting as specified above.
- E. Repair damage to air barriers caused by testing; follow manufacturer's written instructions.
- F. Prepare test and inspection reports.

3.5 CLEANING AND PROTECTION

- A. Protect air-barrier system from damage during application and remainder of construction period, in accordance with manufacturer's written instructions.
 - 1. Protect air barrier from exposure to UV light and harmful weather exposure as

recommended in writing by manufacturer. If exposed to these conditions for longer than recommended, remove and replace air barrier or install additional, full-thickness, air-barrier application after repairing and preparing the overexposed materials in accordance with air-barrier manufacturer's written instructions.

2. Protect air barrier from contact with incompatible materials and sealants not approved by air-barrier manufacturer.
- B. Clean spills, stains, and soiling from construction that would be exposed in the completed Work, using cleaning agents and procedures recommended in writing by manufacturer of affected construction.

END OF SECTION 072715

SECTION 074213.23 - METAL COMPOSITE MATERIAL WALL PANELS

PART 1 - GENERAL

1.1 SUMMARY

- A. Section Includes:
 - 1. Metal composite material (MCM) panels.
 - 2. Metal composite material (MCM) system.
- B. Related Requirements:

1.2 DEFINITIONS

- A. MCM: Metal composite material; cladding material formed by joining two thin metal skins to polyethylene or fire-retardant core and bonded under precise temperature, pressure, and tension.
- B. PER: Pressure-equalized rainscreen system designed for no water intrusion, with equal pressure within air cavity and outside cladding barrier.

1.3 ACTION SUBMITTALS

- A. Product Data: Include construction details, material descriptions, dimensions of individual components and profiles, and finishes for each type of panel, system, and accessory.
 - 1. Metal composite material (MCM) panels.
 - 2. Metal composite material (MCM) system.
- B. Shop Drawings:
 - 1. Include fabrication and installation layouts of MCM system; details of edge conditions, joints, panel profiles, corners, anchorages, attachment assembly, trim, flashings, closures, accessories, and special details.
 - 2. Accessories: Include details of flashing, trim, and anchorage, at a scale of not less than **1-1/2 inches per 12 inches**.
 - 3. Provide signed and sealed drawings, by a qualified design professional in Project jurisdiction, of MCM system showing compliance with performance requirements and design criteria identified for this Project.
- C. Samples for Initial Selection: For each type of MCM panel indicated, with factory-applied color finishes.
 - 1. Size: Manufacturers' standard size.

2. Include Samples of trim and accessories involving color selection.

1.4 INFORMATIONAL SUBMITTALS

A. Test and Evaluation Reports:

1. Product Test Reports: For each MCM panel, for tests performed by qualified testing agency.
 - a. MCM Panel Manufacturer's Material Test Reports: Certified test reports showing compliance with specific performance or third-party listing documenting compliance in accordance with the IBC.
 - b. Fabricator's MCM System Test Reports: Certified test reports showing system compliance with specific performance or third-party listing documenting compliance in accordance with the IBC.

B. Field Quality-Control Submittals:

1. Field quality-control reports.

C. Qualification Statements: For manufacturer fabricator Installer testing agency.

D. Delegated design engineer qualifications.

E. Sample warranties.

1.5 CLOSEOUT SUBMITTALS

A. Maintenance Data: For MCM panels.

B. Warranty Documentation:

1. Manufacturers' special warranties.
2. Installer's special warranties.

1.6 QUALITY ASSURANCE

A. Manufacturer Qualifications: Minimum 5 years' experience.

B. Fabricator Qualifications: Approved by MCM panel manufacturer.

C. Installer Qualifications: Fabricator of MCM system Entity that employs installers and supervisors who are trained and approved by MCM system manufacturer.

D. Delegated Design Engineer Qualifications: A professional engineer who is legally qualified to practice in state where Project is located and who is experienced in providing engineering services of the type indicated.

- E. Testing Agency Qualifications: An agency acceptable to authorities having jurisdiction.

1.7 DELIVERY, STORAGE, AND HANDLING

- A. Deliver components, MCM panels, and other manufactured items so as not to be damaged or deformed. Package MCM panels for protection during transportation and handling.
- B. Unload, store, and erect MCM panels in a manner to prevent bending, warping, twisting, and surface damage.
- C. Stack MCM panels horizontally on platforms or pallets, covered with suitable weathertight and ventilated covering. Store MCM panels to ensure dryness, with positive slope for drainage of water. Do not store MCM panels in contact with other materials that might cause staining, denting, or other surface damage.
- D. Retain strippable protective covering on MCM panels during installation.

1.8 FIELD CONDITIONS

- A. Weather Limitations: Proceed with installation only when existing and forecasted weather conditions permit assembly of MCM panels to be performed in accordance with manufacturers' written instructions and warranty requirements.

1.9 COORDINATION

- A. Coordinate MCM panel installation with rain drainage work, flashing, trim, construction of soffits, and other adjoining work to provide a leakproof, secure, and noncorrosive installation.

1.10 WARRANTY

- A. Panel Integrity Warranty: Manufacturer agrees to repair or replace components of MCM panels that fail in materials or workmanship within specified warranty period.
 - 1. Failures include, but are not limited to, the following:
 - a. Structural failures including rupturing, cracking, or puncturing.
 - b. Deterioration of metals and other materials beyond normal weathering.
 - 2. Warranty Period: Five years from date of Substantial Completion.
- B. Panel Finish Warranty: Manufacturer agrees to repair finish or replace MCM panels that show evidence of deterioration of factory-applied finishes within specified warranty period.
 - 1. Exposed Panel Finish: Deterioration includes, but is not limited to, the following:

- a. Color fading more than 5 Hunter units when tested in accordance with ASTM D2244.
 - b. Chalking in excess of a No. 8 rating when tested in accordance with ASTM D4214.
 - c. Cracking, checking, peeling, or failure of paint to adhere to bare metal.
2. Finish Warranty Period: 30 years from date of Substantial Completion.
- C. MCM System Warranty: System manufacturer's standard form in which manufacturer agrees to repair or replace components of MCM systems that fail in materials or workmanship within specified warranty period.

PART 2 - PRODUCTS

2.1 PERFORMANCE REQUIREMENTS

- A. Delegated Design: Engage a qualified professional engineer, as defined in Section 014000 "Quality Requirements," to design MCM system.
- B. Seismic Performance: No failure or deterioration of the system when laterally racked to **3/4 inch** in both directions and repeated for three cycles in accordance with AAMA 501.4. System must pass the static water test as described in ASTM E331 following the seismic racking.
- C. Structural Performance: MCM systems to withstand the effects of the following loads, based on testing in accordance with ASTM E330/E330M:
1. Wind Loads: As indicated on Drawings.
 2. Deflection Limits: For wind loads, no greater than 1/180 of the span.
- D. Air Infiltration: Air leakage of not more than **0.06 cfm/sq. ft.** when tested in accordance with ASTM E283/E283M at the following test-pressure difference:
- E. Water Penetration under Static Pressure: No water penetration when tested in accordance with ASTM E331 at the following test-pressure difference:
- F. Water Penetration under Dynamic Pressure: No water penetration when tested in accordance with AAMA 501.1 at the following test pressure:
- G. Thermal Movements: Allow for thermal movements from ambient and surface temperature changes.
1. Temperature Change: **120 deg F**, ambient; **180 deg F**, material surfaces.

2.2 METAL COMPOSITE MATERIAL (MCM) WALL PANELS

- A. Metal Composite Material (MCM) Wall Panels: Provide MCM panels fabricated from two metal facings bonded to a solid, extruded thermoplastic core.

1. Basis-of-Design Product: Subject to compliance with requirements, provide Citadel Architectural Products; Panel 20 Two Piece Molding System or Approved Equivalent by one of the following:
 - a. Alcotex Inc.
 - b. Alfrex, LLC
 - c. ALPOLIC
 - d. ALUCOBOND; 3A Composites USA, Inc
 - e. Alucoil North America
 - f. Arconic Architectural Products, LLC
 - g. Carter Architectural Panels, Inc.
 - h. Fairview Architectural
 - i. StacBond
2. Core: PE Thermoset phenolic resin.
3. Panel Thickness: 0.125 inch.
4. Bond Strength: **22.5 in-lb/in.** when tested for bond integrity in accordance with ASTM D1781.
5. Fire Performance: Flame spread index less than 25 and smoke-developed index less than 450, in accordance with ASTM E84 or UL 723.

B. MCM Panel Materials:

1. Aluminum-Faced Panels A, A2: ASTM B209/B209M alloy as standard with manufacturer, temper as required to suit finish and forming operations with aluminum sheet facings.
 - a. Exterior Finish: Two-coat fluoropolymer Mica fluoropolymer.
 - 1) Color: To Match Entrance Door Finish.

C. System Panel Depth: [**1 inch**][**1-1/2 inches**][**1-3/4 inches**][**2 inches**][As indicated by manufacturer's designations][As indicated on drawings]<Insert depth>.

D. Attachment Assembly Components: [**Manufacturer's standard**][**Clips**][**Tracks**][**Channels**]<Insert method> formed from [**extruded aluminum**][**material compatible with panel facing**].

E. Labeling: Comply with labeling requirement of applicable building code.

2.3 ACCESSORIES

- A. Metal Subframing and Furring: ASTM C955 cold-formed, metallic-coated steel sheet ASTM A653/A653M, **G90** hot-dip galvanized coating designation or ASTM A792/A792M, **Class AZ50** aluminum-zinc-alloy coating designation unless otherwise indicated. Provide manufacturer's standard sections as required for support and alignment of MCM system.
- B. System Accessories: Provide components required for a complete, weathertight wall system including trim, copings, fasciae, mullions, sills, corner units, clips, flashings,

sealants, gaskets, fillers, closure strips, and similar items. Match material and finish of MCM panels unless otherwise indicated.

- C. Flashing and Trim: Provide flashing and trim formed from same material as MCM panels as required to seal against weather and to provide finished appearance. Locations include, but are not limited to, bases, drips, sills, jambs, corners, endwalls, framed openings, rakes, fasciae, parapet caps, soffits, reveals, and fillers. Finish flashing and trim with same finish system as adjacent MCM panels.
- D. Panel Fasteners: Self-tapping screws designed to withstand design loads. Use gasketed or approved coated fasteners between dissimilar metals.
 - 1. Aluminum Panels: Use aluminum or stainless steel fasteners for surfaces exposed to the exterior; use aluminum or galvanized-steel fasteners for surfaces exposed to the interior.
 - 2. Copper Panels: Use copper, stainless steel, or hardware-bronze fasteners.
 - 3. Steel, Titanium, or Zinc Panels: Use stainless steel fasteners.
 - 4. Provide exposed fasteners with heads matching color of MCM panels by means of plastic caps or factory-applied coating. Provide EPDM or PVC sealing washers for exposed fasteners.
- E. Panel Sealants: ASTM C920; elastomeric polyurethane or silicone sealant; of type, grade, class, and use classifications required to seal joints in MCM panels and remain weathertight; and as recommended in writing by MCM system manufacturer.

2.4 FABRICATION

- A. Fabricate and finish MCM panels at the factory, by panel manufacturer's standard procedures and processes, as necessary to fulfill indicated panel performance requirements demonstrated by laboratory testing.
- B. Shop-fabricate MCM systems and accessories by fabricator's standard procedures and processes, as necessary to fulfill indicated performance requirements demonstrated by laboratory testing. Comply with requirements of MCM panel manufacturer, of indicated system profiles, and with dimensional and structural requirements.
 - 1. Fabricate panels to dimensions indicated on Drawings based on an assumed design temperature of **70 deg F**. Allow for ambient temperature range at time of fabrication.
 - 2. Formed MCM panel lines, breaks, and angles to be sharp and straight, with surfaces free from warp or buckle.
 - 3. Fabricate panels with sharply cut edges and no displacement of face sheet or protrusion of core.
 - 4. Fabricated Panel Tolerances: Shop-fabricate panels to sizes and joint configurations indicated on Drawings.
 - a. Width: Plus or minus **0.079 inch** at **70 deg F**.
 - b. Length: Plus or minus **0.079 inch** at **70 deg F**.
 - c. Squareness: Plus or minus **0.079 inch** at **70 deg F**.

5. Fabricate MCM panel joints with factory-installed captive gaskets or separator strips that provide a weathertight seal and prevent metal-to-metal contact, and that minimize noise from movements.

- C. Sheet Metal Flashing and Trim: Fabricate flashing and trim to comply with manufacturer's written instructions and recommendations in SMACNA's "Architectural Sheet Metal Manual" that apply to design, dimensions, metal, and other characteristics of item indicated.

1. Form exposed sheet metal accessories that are without excessive oil-canning, buckling, and tool marks and that are true to line and levels indicated, with exposed edges folded back to form hems.
2. Seams for Aluminum: Fabricate nonmoving seams with flat-lock seams. Form seams and seal with epoxy seam sealer. Rivet joints for additional strength.
3. Seams for Other Than Aluminum: Fabricate nonmoving seams in accessories with flat-lock seams.
4. Sealed Joints: Form non-expansion, but movable, joints in metal to accommodate sealant and to comply with SMACNA standards.
5. Conceal fasteners and expansion provisions where possible. Exposed fasteners are not allowed on faces of accessories exposed to view.
6. Fabricate cleats and attachment devices from same material as accessory being anchored or from compatible, noncorrosive metal recommended in writing by metal manufacturer.

- a. Size: As recommended by SMACNA's "Architectural Sheet Metal Manual" or metal manufacturer for application, but not less than thickness of metal being secured.

2.5 FINISHES

- A. Protect mechanical and painted finishes on exposed surfaces from damage by applying a strippable, temporary protective covering before shipping.
- B. Appearance of Finished Work: Noticeable variations in same piece are unacceptable. Variations in appearance of adjoining components are acceptable if they are within the range of approved Samples and are assembled or installed to minimize contrast.
- C. Coil-Coated Metal Finish:
 1. PVDF Fluoropolymer: AAMA 2605, two-coat fluoropolymer finish containing not less than 70 percent PVDF resin by weight in color coat. Prepare, pretreat, and apply coating to exposed metal surfaces to comply with coating and resin manufacturers' written instructions.

PART 3 - EXECUTION

3.1 EXAMINATION

- A. Examine substrates, areas, and conditions, with Installer present, for compliance with requirements for installation tolerances, MCM system supports, and other conditions affecting performance of the Work.
 - 1. Examine wall framing to verify that girts, angles, channels, studs, and other structural panel support members and anchorage have been installed within alignment tolerances required by MCM system manufacturer.
 - 2. Examine wall sheathing to verify that sheathing joints are supported by framing or blocking and that installation is within flatness tolerances required by MCM system manufacturer.
 - a. Verify that air- or water-resistive barriers have been installed over sheathing or backing substrate to prevent air infiltration or water penetration.
- B. Examine roughing-in for components and assemblies penetrating MCM system to verify actual locations of penetrations relative to seam locations of MCM panels before installation.
- C. Proceed with installation only after unsatisfactory conditions have been corrected.

3.2 INSTALLATION OF MCM SYSTEM

- A. General: Install MCM system in accordance with system manufacturer's written instructions in orientation, sizes, and locations indicated on Drawings. Install panels perpendicular to supports unless otherwise indicated. Anchor MCM system securely in place, with provisions for thermal and structural movement.
 - 1. Shim or otherwise plumb substrates receiving MCM system.
 - 2. Flash and seal MCM system at perimeter of all openings. Fasten with self-tapping screws.
 - 3. Install screw fasteners in predrilled holes.
 - 4. Locate and space fastenings in uniform vertical and horizontal alignment.
 - 5. Install flashing and trim as MCM system work proceeds.
 - 6. Align bottoms of MCM panels and fasten with blind rivets, bolts, or self-tapping screws. Fasten flashings and trim around openings and similar elements with self-tapping screws.
 - 7. Provide weathertight escutcheons for all items penetrating system.
 - 8. Where dissimilar metals contact each other or corrosive substrates, protect against galvanic action as recommended in writing by MCM system manufacturer.
 - 9. Attach MCM panels to supports at locations, spacings, and with fasteners recommended by manufacturer to meet listed performance requirements.
- B. Attachment Assembly, General: Install attachment assembly required to support MCM

panels and to provide a complete weathertight wall system, including tracks, drainage channels, anchor channels, perimeter extrusions, and panel clips.

1. Install subframing, furring, and other panel support members and anchorages in accordance with ASTM C955.
2. Install support system at locations, at spacings, and with fasteners recommended by MCM system manufacturer to meet listed performance requirements.
3. Provide Two Piece Molding System: Field-assembled installation system consisting of exterior cladding panels, trim moldings, silicone sealant, and accessories to provide a barrier system.

a. System is sealed with a Silicone Sealant, typically Tremco Spectrem 2

- C. Install panels to allow individual panels to "free float" and be installed and removed without disturbing adjacent panels.
- D. Install accessories with positive anchorage to building and weathertight mounting, and provide for thermal expansion. Coordinate installation with flashings and other components.
1. Install accessory components required for a complete MCM system assembly including trim, copings, corners, seam covers, flashings, sealants gaskets, fillers, closure strips, and similar items. Provide types indicated by MCM system manufacturer.
- E. Flashing and Trim: Comply with performance requirements, manufacturer's written installation instructions, and SMACNA's "Architectural Sheet Metal Manual." Provide concealed fasteners where possible, and set units true to line and level as indicated. Install work with laps, joints, and seams that are permanently watertight.
1. Install exposed flashing and trim that is without buckling and tool marks and that is true to line and levels indicated, with exposed edges folded back to form hems. Install trim to fit substrates and to result in waterproof performance.
 2. Expansion Provisions: Provide for thermal expansion of exposed flashing and trim. Space movement joints at a maximum of **10 ft.** with no joints allowed within **24 inches** of corner or intersection. Where lapped expansion provisions cannot be used or would not be sufficiently waterproof, form expansion joints of intermeshing hooked flanges, not less than **1 inch** deep, filled with mastic sealant (concealed within joints).

3.3 INSTALLATION TOLERANCES

- A. Shim and align MCM panels within installed tolerance of **1/4 inch in 20 ft.**, non-accumulative, on level, plumb, and location lines as indicated, and within **1/8-inch** offset of adjoining faces and of alignment of matching profiles.

3.4 FIELD QUALITY CONTROL

- A. Testing Agency: Engage a qualified testing agency to perform tests and inspections.

- B. Manufacturer's Field Service: Engage a factory-authorized service representative to test and inspect completed MCM system installation, including accessories.
- C. MCM system will be considered defective if it does not pass test and inspections.
- D. Additional tests and inspections, at Contractor's expense, are performed to determine compliance of replaced or additional work with specified requirements.
- E. Prepare test and inspection reports.

3.5 CLEANING

- A. Remove temporary protective coverings and strippable films as MCM panels are installed unless otherwise indicated in manufacturer's written installation instructions. On completion of installation, clean finished surfaces as recommended by MCM panel manufacturer. Maintain in a clean condition during construction.
- B. After installation, clear weep holes and drainage channels of obstructions, dirt, and sealant.

3.6 PROTECTION

- A. Replace MCM panels that have been damaged or have deteriorated beyond successful repair by finish touchup or similar minor repair procedures.

END OF SECTION 074213.23

SECTION 074293 - SOFFIT PANELS

PART 1 - GENERAL

1.1 SUMMARY

- A. Section Includes:
 - 1. Metal soffit panels.
- B. Related Requirements:

1.2 ACTION SUBMITTALS

- A. Product Data:
 - 1. Metal soffit panels.
- B. Product Data Submittals:
 - 1. Include construction details, material descriptions, dimensions of individual components and profiles, and finishes for each type of panel and accessory.
- C. Shop Drawings:
 - 1. Include fabrication and installation layouts of metal panels; details of edge conditions, joints, panel profiles, corners, anchorages, attachment system, trim, flashings, closures, and accessories; and special details.
 - 2. Accessories: Include details of flashing, trim, and anchorage systems, at a scale of not less than **1-1/2 inches per 12 inches**.
- D. Samples for Verification: For each type of exposed finish required, prepared on Samples of size indicated below:
 - 1. Metal Panels: **12 inches** long by actual panel width. Include fasteners, closures, and other metal panel accessories.

1.3 INFORMATIONAL SUBMITTALS

- A. Qualification Data: For Installer.
- B. Product Test Reports: For each product, tests performed by a qualified testing agency.
- C. Sample Warranties: For special warranties.

1.4 CLOSEOUT SUBMITTALS

- A. Maintenance Data: For metal panels to include in maintenance manuals.

1.5 QUALITY ASSURANCE

- A. Installer Qualifications: An entity that employs installers and supervisors who are trained and approved by manufacturer.
- B. UL-Certified, Portable Roll-Forming Equipment: UL-certified, portable roll-forming equipment capable of producing metal panels warranted by manufacturer to be the same as factory-formed products. Maintain UL certification of portable roll-forming equipment for duration of work.

1.6 FIELD CONDITIONS

- A. Weather Limitations: Proceed with installation only when existing and forecasted weather conditions permit assembly of metal panels to be performed according to manufacturers' written instructions and warranty requirements.

1.7 WARRANTY

- A. Special Warranty: Manufacturer's standard form in which manufacturer agrees to repair or replace components of metal panel systems that fail in materials or workmanship within specified warranty period.

- 1. Failures include, but are not limited to, the following:

- a. Structural failures including rupturing, cracking, or puncturing.
- b. Deterioration of metals and other materials beyond normal weathering.

- 2. Warranty Period: Two years from date of Substantial Completion.

- B. Special Warranty on Panel Finishes: Manufacturer's standard form in which manufacturer agrees to repair finish or replace metal panels that show evidence of deterioration of factory-applied finishes within specified warranty period.

- 1. Exposed Panel Finish: Deterioration includes, but is not limited to, the following:

- a. Color fading more than 5 Delta E units when tested according to ASTM D2244.
- b. Chalking in excess of a No. 8 rating when tested according to ASTM D4214.
- c. Cracking, checking, peeling, or failure of paint to adhere to bare metal.

- 2. Finish Warranty Period: 15 years from date of Substantial Completion.

PART 2 - PRODUCTS

2.1 PERFORMANCE REQUIREMENTS

- A. Structural Performance: Provide metal panel systems capable of withstanding the effects of the following loads, based on testing according to ASTM E1592:
 - 1. Wind Loads: As indicated on Drawings.
 - 2. Other Design Loads: As indicated on Drawings.
 - 3. Deflection Limits: For wind loads, no greater than 1/180 of the span.
- B. Air Infiltration: Air leakage of not more than **0.06 cfm/sq. ft.** when tested according to ASTM E283 at the following test-pressure difference:
 - 1. Test-Pressure Difference: **1.57 lbf/sq. ft.**
- C. Water Penetration under Static Pressure: No water penetration when tested according to ASTM E331 at the following test-pressure difference:
 - 1. Test-Pressure Difference: **2.86 lbf/sq. ft.**
- D. Thermal Movements: Allow for thermal movements from ambient and surface temperature changes by preventing buckling, opening of joints, overstressing of components, failure of joint sealants, failure of connections, and other detrimental effects. Base calculations on surface temperatures of materials due to both solar heat gain and nighttime-sky heat loss.
 - 1. Temperature Change (Range): **120 deg F**, ambient; **180 deg F**, material surfaces.

2.2 METAL SOFFIT PANELS

- A. Provide metal soffit panels designed to be installed by lapping and interconnecting side edges of adjacent panels and mechanically attaching through panel to supports using concealed fasteners in side laps. Include accessories required for weathertight installation.
- B. Metal Soffit Panels: Match profile and material of metal panels.
 - 1. Finish: As indicated on Drawings.
 - 2. Sealant: Factory applied within interlocking joint.
- C. Flush-Profile Metal Soffit Panels: Solid panels formed with vertical panel edges and between panel edges; with flush joint between panels.
 - 1. Basis-of-Design Product: Subject to compliance with requirements, provide Longboard; Panelboard Soffit System, 6" Smooth Planks or Approved Equivalent product by one of the following:

- a. AEP Span a brand of ASC Profiles LLC, a part of BlueScope
 - b. ATAS International, Inc.
 - c. Berridge Manufacturing Company
 - d. CENTRIA, a Nucor Brand
 - e. Dimensional Metals, Inc.
 - f. Drexel Metals Corp.
 - g. Elevate; Amrize Building Envelope LLC
 - h. Englert, Inc.
 - i. Fabral; a brand of Flack Global Metals
 - j. Innovative Metals Company, Inc
 - k. Knotwood US LLC
 - l. MBCI; Cornerstone Building Brands
 - m. McElroy Metal, Inc
 - n. Merchant & Evans Inc.
 - o. Metal Sales Manufacturing Corporation
 - p. PAC-CLAD; Petersen; a Carlisle company
 - q. Sentrigard; NB Handy Company
 - r. Ultra Seam Incorporated
2. Aluminum Sheet: Coil-coated sheet, **ASTM B209**, alloy as standard with manufacturer, with temper as required to suit forming operations and structural performance required.
 - a. Thickness: 6063-T5 Extruded Aluminum.
 - b. Surface: Smooth, flat finish.
 - c. Exterior Finish: Woodgrain.
 - d. Color: Light Bamboo.
 3. Panel Coverage: 6 inches..
 4. Panel Height: 7/16 inch.

2.3 MISCELLANEOUS MATERIALS

- A. Miscellaneous Metal Subframing and Furring: ASTM C645, cold-formed, metallic-coated steel sheet, ASTM A653/A653M, **G90** hot-dip galvanized coating designation or ASTM A792/A792M, **Class AZ50** aluminum-zinc-alloy coating designation unless otherwise indicated. Provide manufacturer's standard sections as required for support and alignment of metal panel system.
- B. Panel Accessories: Provide components required for a complete, weathertight panel system including trim, clips, flashings, sealants, gaskets, fillers, closure strips, and similar items. Match material and finish of metal panels unless otherwise indicated.
 1. Closure Strips: Closed-cell, expanded, cellular, rubber or crosslinked, polyolefin-foam or closed-cell laminated polyethylene; minimum **1-inch**- thick, flexible closure strips; cut or premolded to match metal panel profile. Provide closure strips where indicated or necessary to ensure weathertight construction.
- C. Flashing and Trim: Provide flashing and trim formed from same material as metal panels as required to seal against weather and to provide finished appearance. Finish

flashing and trim with same finish system as adjacent metal panels.

- D. Panel Fasteners: Self-tapping screws designed to withstand design loads. Provide exposed fasteners with heads matching color of metal panels by means of plastic caps or factory-applied coating. Provide EPDM or PVC sealing washers for exposed fasteners.
- E. Panel Sealants: Provide sealant types recommended by manufacturer that are compatible with panel materials, are nonstaining, and do not damage panel finish.
 - 1. Sealant Tape: Pressure-sensitive, 100 percent solids, gray polyisobutylene compound sealant tape with release-paper backing. Provide permanently elastic, nonsag, nontoxic, nonstaining tape **1/2 inch** wide and **1/8 inch** thick.
 - 2. Joint Sealant: ASTM C920; elastomeric polyurethane or silicone sealant; of type, grade, class, and use classifications required to seal joints in metal panels and remain weathertight; and as recommended in writing by metal panel manufacturer.
 - 3. Butyl-Rubber-Based, Solvent-Release Sealant: ASTM C1311.

2.4 FABRICATION

- A. Fabricate and finish metal panels and accessories at the factory, by manufacturer's standard procedures and processes, as necessary to fulfill indicated performance requirements demonstrated by laboratory testing. Comply with indicated profiles and with dimensional and structural requirements.
- B. Provide panel profile, including major ribs and intermediate stiffening ribs, if any, for full length of panel.
- C. Fabricate metal panel joints with factory-installed captive gaskets or separator strips that provide a weathertight seal and prevent metal-to-metal contact, and that minimize noise from movements.
- D. Sheet Metal Flashing and Trim: Fabricate flashing and trim to comply with manufacturer's recommendations and recommendations in SMACNA's "Architectural Sheet Metal Manual" that apply to design, dimensions, metal, and other characteristics of item indicated.
 - 1. Form exposed sheet metal accessories that are without excessive oil canning, buckling, and tool marks and that are true to line and levels indicated, with exposed edges folded back to form hems.
 - 2. Seams for Aluminum: Fabricate nonmoving seams with flat-lock seams. Form seams and seal with epoxy seam sealer. Rivet joints for additional strength.
 - 3. Seams for Other Than Aluminum: Fabricate nonmoving seams in accessories with flat-lock seams. Tin edges to be seamed, form seams, and solder.
 - 4. Sealed Joints: Form nonexpansion, but movable, joints in metal to accommodate sealant and to comply with SMACNA standards.
 - 5. Conceal fasteners and expansion provisions where possible. Exposed fasteners are not allowed on faces of accessories exposed to view.
 - 6. Fabricate cleats and attachment devices from same material as accessory being

anchored or from compatible, noncorrosive metal recommended in writing by metal panel manufacturer.

- a. Size: As recommended by SMACNA's "Architectural Sheet Metal Manual" or metal soffit panel manufacturer for application but not less than thickness of metal being secured.

2.5 FINISHES

- A. Protect mechanical and painted finishes on exposed surfaces from damage by applying a strippable, temporary protective covering before shipping.
- B. Appearance of Finished Work: Variations in appearance of abutting or adjacent pieces are acceptable if they are within one-half of the range of approved Samples. Noticeable variations in same piece are not acceptable. Variations in appearance of other components are acceptable if they are within the range of approved Samples and are assembled or installed to minimize contrast.
- C. Steel Panels and Accessories:
 1. Three-Coat Fluoropolymer: AAMA 621. Fluoropolymer finish containing not less than 70 percent polyvinylidene fluoride (PVDF) resin by weight in both color coat and clear topcoat. Prepare, pretreat, and apply coating to exposed metal surfaces to comply with coating and resin manufacturers' written instructions.
- D. Aluminum Panels and Accessories:
 1. Two-Coat Fluoropolymer: AAMA 2605. Fluoropolymer finish containing not less than 70 percent polyvinylidene fluoride (PVDF) resin by weight in color coat. Prepare, pretreat, and apply coating to exposed metal surfaces to comply with coating and resin manufacturers' written instructions.
 2. Durable Polyurethane Powders & Sublimation inks for Woodgrain finishes.
 3. Exposed Anodized Finish:
 - a. Clear Anodic Finish: AAMA 611, AA-M12C22A41, Class I, 0.018 mm or thicker.
 - b. Color Anodic Finish: AAMA 611, AA-M12C22A42/A44, Class I, 0.018 mm or thicker.

PART 3 - EXECUTION

3.1 INSTALLATION OF METAL SOFFIT PANELS

- A. Install metal panels according to manufacturer's written instructions in orientation, sizes, and locations indicated. Install panels perpendicular to supports unless otherwise indicated. Anchor metal panels and other components of the Work securely in place, with provisions for thermal and structural movement.

1. Shim or otherwise plumb substrates receiving metal panels.
 2. Flash and seal metal panels at perimeter of all openings. Fasten with self-tapping screws. Do not begin installation until air- or water-resistive barriers and flashings that will be concealed by metal panels are installed.
 3. Install screw fasteners in predrilled holes.
 4. Locate and space fastenings in uniform vertical and horizontal alignment.
 5. Install flashing and trim as metal panel work proceeds.
 6. Locate panel splices over, but not attached to, structural supports. Stagger panel splices and end laps to avoid a four-panel lap splice condition.
 7. Provide weathertight escutcheons for pipe- and conduit-penetrating panels.
- B. Fasteners:
1. Steel Panels: Use stainless steel fasteners for surfaces exposed to the exterior; use galvanized-steel fasteners for surfaces exposed to the interior.
 2. Aluminum Panels: Use aluminum or stainless steel fasteners for surfaces exposed to the exterior; use aluminum or galvanized-steel fasteners for surfaces exposed to the interior.
 3. Copper Panels: Use copper, stainless steel, or hardware-bronze fasteners.
 4. Stainless Steel Panels: Use stainless steel fasteners.
- C. Metal Protection: Where dissimilar metals contact each other or corrosive substrates, protect against galvanic action as recommended in writing by metal panel manufacturer.
- D. Lap-Seam Metal Panels: Fasten metal panels to supports with fasteners at each lapped joint at location and spacing recommended by manufacturer.
1. Apply panels and associated items true to line for neat and weathertight enclosure.
 2. Provide metal-backed washers under heads of exposed fasteners bearing on weather side of metal panels.
 3. Locate and space exposed fasteners in uniform vertical and horizontal alignment. Use proper tools to obtain controlled uniform compression for positive seal without rupture of washer.
 4. Install screw fasteners with power tools having controlled torque adjusted to compress washer tightly without damage to washer, screw threads, or panels. Install screws in predrilled holes.
- E. Watertight Installation:
1. Apply a continuous ribbon of sealant or tape to seal lapped joints of metal panels, using sealant or tape as recommend by manufacturer on side laps of nesting-type panels and elsewhere as needed to make panels watertight.
 2. Provide sealant or tape between panels and protruding equipment, vents, and accessories.
 3. At panel splices, nest panels with minimum **6-inch** end lap, sealed with sealant and fastened together by interlocking clamping plates.
- F. Accessory Installation: Install accessories with positive anchorage to building and

weathertight mounting, and provide for thermal expansion. Coordinate installation with flashings and other components.

1. Install components required for a complete metal panel system including trim, corners, seam covers, flashings, sealants, gaskets, fillers, closure strips, and similar items. Provide types indicated by metal panel manufacturer; or, if not indicated, provide types recommended by metal panel manufacturer.
- G. Flashing and Trim: Comply with performance requirements, manufacturer's written installation instructions, and SMACNA's "Architectural Sheet Metal Manual." Provide concealed fasteners where possible, and set units true to line and level as indicated. Install work with laps, joints, and seams that are permanently watertight.
1. Install exposed flashing and trim that is without buckling, and tool marks, and that is true to line and levels indicated, with exposed edges folded back to form hems. Install sheet metal flashing and trim to fit substrates and to achieve waterproof performance.
 2. Expansion Provisions: Provide for thermal expansion of exposed flashing and trim. Space movement joints at a maximum of **10 feet** with no joints allowed within **24 inches** of corner or intersection. Where lapped expansion provisions cannot be used or would not be waterproof, form expansion joints of intermeshing hooked flanges, not less than **1 inch** deep, filled with mastic sealant (concealed within joints).

END OF SECTION 074293

SECTION 075423 - THERMOPLASTIC-POLYOLEFIN (TPO) ROOFING

PART 1 - GENERAL

1.1 SUMMARY

A. Section Includes:

1. Thermoplastic polyolefin (TPO) roofing system.
2. Accessory roofing system materials.
3. Roof insulation and accessories.

B. Related Requirements:

1. Section 061000 "Rough Carpentry" for wood nailers, curbs, and blocking; and for wood-based, structural-use roof deck panels.
2. Section 061600 "Sheathing" for wood-based, structural-use roof deck panels.
3. Section 076200 "Sheet Metal Flashing and Trim" for metal roof flashings and counterflashings.
4. Section 077100 "Roof Specialties" for roof edge flashings counterflashings.
5. Section 077200 "Roof Accessories" for manufactured roof curbs, equipment supports, roof hatches, vents, and other manufactured roof accessory units.
6. Section 079200 "Joint Sealants" for joint sealants, joint fillers, and joint preparation.

1.2 DEFINITIONS

- ##### A. Roofing Terminology: Definitions in ASTM D1079 and glossary in NRCA's "Roofing Manual: Membrane Roof Systems" apply to Work of this Section.

1.3 ACTION SUBMITTALS

- ##### A. Product Data: For each type of product.

- ##### B. Shop Drawings: Include roof plans, sections, details, and attachments to other work, including the following:

1. Layout and thickness of insulation.
2. Base and sheet flashings and membrane termination details.
3. Flashing details at penetrations.
4. Tapered insulation layout, thickness, and slopes.
5. Roof plan showing orientation of roof deck and orientation of roofing membrane, fastening spacings, and pattern for corner, perimeter, and field-of-roof locations.
6. Insulation fastening patterns for corner, perimeter, and field-of-roof locations.
7. Crickets, saddles, and tapered edge strips, including slopes.
8. Tie-in with adjoining wall system air barrier.

- C. Samples for Verification: For the following products:
 - 1. Roofing membrane and flashings, of color required.
- D. Wind-Uplift-Resistance Submittal: For roofing system indicating compliance with wind-uplift performance requirements.
- E. Sustainable Design Submittals:

1.4 INFORMATIONAL SUBMITTALS

- A. Manufacturer Certificates:
 - 1. Special Warranty Certificate: Signed by roofing membrane manufacturer, certifying that all materials supplied under this Section are acceptable for special warranty.
- B. Field quality control reports.
- C. Qualification Statements: For roofing system Installer manufacturer and testing agency.
- D. Sample warranties.

1.5 CLOSEOUT SUBMITTALS

- A. Maintenance Data: For roofing system.
- B. Certified statement from existing roofing system manufacturer stating that existing roof warranty has not been affected by the Work performed under this Section.

1.6 QUALITY ASSURANCE

- A. Manufacturer Qualifications: A qualified manufacturer that is listed in SPRI's "Directory of Roof Assemblies" for roofing system identical to that used for this Project.
- B. Roofing System Installer Qualifications: A qualified firm that is approved, authorized, or licensed by roofing system manufacturer to install manufacturer's product and that is eligible to receive manufacturer's special warranty.
 - 1. Certified Roofing System Installer: Entity that employs a supervisor who is an NRCA ProCertified Roofing Foreman or installers who are NRCA ProCertified thermoplastic system installers.

1.7 DELIVERY, STORAGE, AND HANDLING

- A. Deliver roofing system materials to Project site in original containers with seals unbroken and labeled with manufacturer's name, product brand name and type, date of

manufacture, approval or listing agency markings, and directions for storing and mixing with other components.

- B. Store liquid materials in their original undamaged containers in a clean, dry, protected location and within the temperature range required by roofing system manufacturer.
 - 1. Protect stored liquid material from direct sunlight.
 - 2. Discard and legally dispose of liquid material that cannot be applied within its stated shelf life.
- C. Protect roof insulation materials from physical damage and from deterioration by sunlight, moisture, soiling, and other sources.
 - 1. Store in a dry location.
 - 2. Comply with insulation manufacturer's written instructions for handling, storing, and protecting during installation.
- D. Handle and store roofing system materials, and place equipment in a manner to avoid permanent deflection of deck.

1.8 FIELD CONDITIONS

- A. Weather Limitations: Proceed with installation only when existing and forecasted weather conditions permit roofing system to be installed in accordance with manufacturer's written installation instructions and warranty requirements.

1.9 WARRANTY

- A. Roofing System Installer's Warranty: Submit roofing system Installer's warranty, on warranty form at end of this Section, signed by roofing system Installer, covering the Work of this Section, including all components of roofing system, such as substrate board, roof insulation, fasteners, adhesives, roofing membrane, base flashing sheet, and other components of roofing system.
 - 1. Warranty Period: Two years from date of Substantial Completion.

PART 2 - PRODUCTS

2.1 SOURCE LIMITATIONS

- A. Obtain components for roofing system from roofing membrane manufacturer.

2.2 PERFORMANCE REQUIREMENTS

- A. General Performance: Installed roofing system and flashings to withstand specified uplift pressures, thermally induced movement, and exposure to weather without failure

due to defective manufacture, fabrication, installation, or other defects in construction. Roofing system and flashings to remain watertight.

1. Accelerated Weathering: Roofing membrane to withstand 2000 hours of exposure when tested in accordance with ASTM G152, ASTM G154, or ASTM G155.
 2. Impact Resistance: Roofing membrane to resist impact damage when tested in accordance with ASTM D3746/D3746M, ASTM D4272/D4272M, or the Resistance to Foot Traffic Test in FM Approvals 4470.
- B. Material Compatibility: Roofing system materials to be compatible with one another and adjacent materials under conditions of service and application required, as demonstrated by roofing membrane manufacturer based on testing and field experience.
- C. Wind-Uplift Resistance: Design roofing system to resist the following wind-uplift pressures when tested in accordance with FM Approvals 4474, UL 580, or UL 1897:
1. Zone 1 (Roof Area Field): **100 lbf/sq. ft..**
 2. Zone 2 (Roof Area Perimeter): **100 lbf/sq. ft..**
 3. Zone 3 (Roof Area Corners): **100 lbf/sq. ft..**
- D. SPRI's "Directory of Roof Assemblies" Listing: Roofing membrane, base flashings, and component materials to comply with requirements in FM Approvals 4450 or FM Approvals 4470 as part of a roofing system and are listed in SPRI's "Directory of Roof Assemblies" for roof assembly identical for that specified for this Project.
1. Wind-Uplift Load Capacity: 107 psf per Structural Drawings.
- 2.3 THERMOPLASTIC POLYOLEFIN (TPO) ROOFING SYSTEM
- A. TPO Roofing Membrane Sheet: ASTM D6878/D6878M, internally fabric- or scrim-reinforced, TPO sheet.
1. Basis-of-Design Product: Subject to compliance with requirements, provide Johns Manville; TPO Roofing Membrane or comparable product by one of the following:
 - a. Carlisle Syntec Systems
 - b. Cooley Group
 - c. Custom Seal Inc.
 - d. Elevate; Amrize Building Envelope LLC
 - e. Flex Membrane International Corp.
 - f. GAF
 - g. GenFlex Roofing Systems
 - h. IKO Innovati; IKO Industries Inc.
 - i. Mule-Hide Products Co., Inc
 - j. Siplast
 - k. Versico Roofing Systems; Carlisle Construction Materials

2. Thickness: **60 mils**, nominal.
3. Exposed Face Color: Gray.

2.4 ACCESSORY ROOFING SYSTEM MATERIALS

- A. General: Accessory materials as recommended in writing by roofing membrane manufacturer for intended use and compatible with other roofing system components.
 1. Adhesive and Sealants: Comply with VOC limits of authorities having jurisdiction.
- B. Base and Sheet Flashings: Manufacturer's standard sheet flashing of same material, type, reinforcement, thickness, and color as roofing membrane.
- C. Prefabricated Pipe Flashings: As recommended in writing by roofing membrane manufacturer.
- D. Roof Vents: As recommended in writing by roofing membrane manufacturer.
 1. Size: Not less than **4-inch** diameter.
- E. Bonding Adhesive: Roofing membrane manufacturer's standard, water based.
- F. Slip Sheet: Manufacturer's standard, of thickness required for application.
- G. Metal Termination Bars: Manufacturer's standard, predrilled stainless steel or aluminum bars, approximately **1 by 1/8 inch** thick; with anchors.
- H. Fasteners: Factory-coated steel fasteners and metal or plastic plates complying with corrosion-resistance provisions in FM Approvals 4470, designed for fastening roofing system components to substrate; tested for required pullout strength, and acceptable to roofing membrane manufacturer.
- I. Safety Accessories: Roofing membrane manufacturer's standard yellow seaming tape for designating safety perimeters and rooftop hazards.
- J. Miscellaneous Accessories: As recommended in writing by roofing membrane manufacturer.
- K. Fiber-Reinforced Gypsum Roof Board: ASTM C1278/C1278M, cellulosic-fiber reinforced, water-resistant gypsum board.
 1. Thickness: [**1/4 inch**][**3/8 inch**][**1/2 inch**][**5/8 inch**].
- L. Perlite Board: ASTM C728, seal coated.
 1. Thickness: [**3/4 inch**][**1 inch**].
- M. Fasteners: Factory-coated steel fasteners and metal or plastic plates complying with corrosion-resistance provisions in FM Approvals 4470, designed for fastening substrate board to roof deck.

- N. Bonding Adhesive: Manufacturer's standard, designed for adhering substrate board to roof deck.
- O. Rubberized-Asphalt-Sheet Vapor Retarder, Self-Adhering: ASTM D1970/D1970M, polyethylene film laminated to layer of rubberized asphalt adhesive, minimum **40-mil** total thickness; maximum permeance rating of **0.1 perm**; cold applied, with slip-resisting surface and release paper backing. Provide primer when recommended by vapor retarder manufacturer.
- P. Butyl-Rubber-Sheet Vapor Retarder, Self-Adhering: Polyethylene film laminated to layer of butyl rubber adhesive, minimum **30-mil** total thickness; maximum permeance rating of **0.1 perm**; cold applied, with slip-resisting surface and release paper backing. Provide primer when recommended by vapor retarder manufacturer.

2.5 ROOF INSULATION AND ACCESSORIES

- A. Polyisocyanurate Board Insulation: ASTM C1289, Type II, Class 1 felt facer on both major surfaces.
 - 1. Basis-of-Design Product: Subject to compliance with requirements, provide Johns Manville; ENRGY 3 or comparable product by one of the following:
 - a. Atlas Polyiso Roof and Wall Insulation
 - b. Carlisle Syntec Systems
 - c. CertainTeed; SAINT-GOBAIN
 - d. Elevate; Amrize Building Envelope LLC
 - e. GAF
 - f. Hunter Panels; a Carlisle company
 - g. IKO Innov; IKO Industries Inc.
 - h. Insulfoam; a Carlisle Company
 - i. Kingspan Insulation LLC
 - j. Polyglass U.S.A., Inc.
 - k. Rmax, A Business Unit of Sika Corporation
 - 2. Compressive Strength: Grade 2, **20 psi**.
 - 3. Size: **48 by 48 inches 48 by 96 inches**.
 - 4. Thickness:
 - a. Base Layer: **1-1/2 inches**.
 - b. Upper Layer: Per drawings..
 - c. Flute fill per drawings.
- B. Roof Insulation Accessories, General: As recommended in writing by insulation manufacturer for intended use and compatibility with other roofing system components.

2.6 COVER BOARD

- A. General: Cover board as recommended in writing by roofing membrane manufacturer for intended use and compatible with other roofing system components.

- B. High-Density Polyisocyanurate Cover Board: ASTM C1289 Type II, Class 4, Grade 1, **1 inch** thick, with a minimum compressive strength of **80 psi**.
 - 1. Or as Recommended by Manufacturer.
- C. Aggregate Ballast: [**Smooth, washed, riverbed gravel or other acceptable smooth-faced stone**][**Crushed gravel or crushed stone**] that withstands weather exposure without significant deterioration and does not contribute to membrane degradation, of the following size:
 - 1. Size: ASTM D448, [**Size 2, ranging in size from 1-1/2 to 2-1/2 inches**][**Size 3, ranging in size from 1 to 2 inches**][**Size 4, ranging in size from 3/4 to 1-1/2 inches**]**<Insert size>**.
- D. Ballast Retaining Bar: Perimeter securement system consisting of a slotted extruded-aluminum retention bar with an integrated compression fastening strip.
 - 1. Fasteners: **1-1/2-inch** stainless steel fasteners with neoprene washers.
- E. Flexible Walkways: Factory-formed, nonporous, heavy-duty, slip-resisting, surface-textured walkway [**pads**][**or**][**rolls**], approximately **3/16 inch** thick and acceptable to roofing system manufacturer.
 - 1. Size: Approximately **36 by 60 inches**.
 - 2. Color: Contrasting with roofing membrane.

PART 3 - EXECUTION

3.1 EXAMINATION

- A. Examine substrates, areas, and conditions, with roofing system Installer present, for compliance with requirements and other conditions affecting performance of the Work.
 - 1. Verify that roof openings and penetrations are in place, curbs are set and braced, and roof-drain bodies are securely clamped in place.
 - 2. Verify that wood blocking, curbs, and nailers are securely anchored to roof deck at penetrations and terminations and that nailers match thicknesses of insulation.
 - 3. Verify that surface plane flatness and fastening of steel roof deck complies with requirements in Section 053100 "Steel Decking."
- B. Proceed with installation only after unsatisfactory conditions have been corrected.

3.2 PREPARATION

- A. Clean substrate of dust, debris, moisture, and other substances detrimental to roofing system installation in accordance with roofing system manufacturer's written instructions. Remove sharp projections.

- B. Prevent materials from entering and clogging roof drains and conductors and from spilling or migrating onto surfaces of other construction. Remove roof-drain plugs when no work is taking place or when rain is forecast.
- C. Prime surface of concrete deck with primer in accordance with roofing system manufacturer's written installation instructions and allow primer to dry.
- D. Perform fastener-pullout tests in accordance with roofing system manufacturer's written instructions.
 - 1. Submit test result within 24 hours after performing tests.
 - a. Include manufacturer's requirements for any revision to previously submitted fastener patterns required to achieve specified wind uplift requirements.
- E. Install sound-absorbing insulation strips in ribs of acoustical steel roof deck in accordance with roof deck manufacturer's written instructions.

3.3 INSTALLATION OF THERMOPLASTIC-POLYOLEFIN (TPO) ROOFING SYSTEM, GENERAL

- A. Install roofing system materials and components in accordance with roofing system manufacturer's written installation instructions, listed roof assembly requirements, and FM Global Property Loss Prevention Data Sheet 1-29.
- B. Complete terminations and base flashings and provide temporary seals to prevent water from entering completed sections of roofing system at end of workday or when rain is forecast. Remove and discard temporary seals before beginning Work on adjoining roofing.
- C. Install roofing membrane and auxiliary materials to tie in to existing roofing to maintain weathertightness of transition.
- D. Coordinate installation and transition of roofing system component serving as an air barrier with wall system air barrier specified under Section 072715 "Nonbituminous Self-Adhering Sheet Air Barriers."
- E. Substrate-Joint Penetrations: Prevent adhesives from penetrating substrate joints, entering building, or damaging roofing system components or adjacent building construction.

3.4 INSTALLATION OF ROOF INSULATION AND ACCESSORIES

- A. Coordinate installation of roofing system components so insulation is not exposed to precipitation or left exposed at end of workday.
- B. Comply with roofing system and insulation manufacturer's written installation instructions. Install minimum of two layers of insulation under area of roofing to achieve

required thickness.

- C. Install each layer of insulation with joints staggered not less than **24 inches** in adjacent rows and offset not less than **12 inches** from previous layer.
 - 1. Trim insulation neatly to fit around penetrations and projections, and to fit tightly to intersecting sloping roof decks.
 - 2. Make joints between adjacent insulation boards not more than **1/4 inch** in width.
 - 3. At internal roof drains, slope insulation to create a square drain sump, with each side equal to the diameter of the drain bowl plus **24 inches**.
 - 4. Trim insulation, so that water flow is unrestricted.
 - 5. Fill gaps exceeding **1/4 inch** with insulation.
 - 6. Cut and fit insulation within **1/4 inch** of nailers, projections, and penetrations.
 - 7. Secure insulation to resist specified uplift pressure at corners, perimeter, and field of roof.
 - 8. Loosely lay each layer of insulation over substrate.

3.5 INSTALLATION OF TPO ROOFING MEMBRANE

- A. Install roofing membrane over roof area for application method in accordance with roofing system manufacturer's written installation instructions.
- B. Unroll roofing membrane and allow it to relax before installing.
- C. Accurately align roofing membrane and maintain uniform side and end laps of minimum dimensions required by manufacturer. Stagger end laps. Apply roofing membrane with side laps shingled with slope of roof deck where possible.
- D. Adhered Application: Apply bonding adhesive to substrate and underside of roofing membrane at rate required by manufacturer and allow to partially dry before installing roofing membrane. Do not apply to splice area of roofing membrane.
 - 1. In addition to adhering, mechanically fasten roofing membrane securely at terminations, penetrations, and perimeter of roof area.
- E. Seams and End Laps: Clean seam areas, overlap membrane, and hot-air-weld side seams and end laps of roofing membrane and sheet flashings to ensure a watertight installation.
 - 1. Test lap edges with probe to verify seam weld continuity. Apply lap sealant to seal cut edges of roofing membrane and sheet flashings.
 - 2. Verify field strength of seams a minimum of twice daily, and repair seam sample areas.
 - 3. Repair tears, voids, and lapped seams in roofing membrane that do not comply with requirements.
- F. Spread sealant bed over deck-drain flange at roof drains, and securely seal roofing membrane in place with clamping ring.

3.6 INSTALLATION OF BASE AND SHEET FLASHINGS

- A. General: Install and adhere base and sheet flashing and preformed flashing accessories to substrates in accordance with roofing system manufacturer's written installation instructions.
- B. Apply bonding adhesive to substrate and underside of flashings at required rate and allow to partially dry. Do not apply to seam area of flashing.
- C. Flash penetrations and field-formed inside and outside corners.
- D. Clean seam areas, overlap, and firmly roll flashings into the adhesive. Hot-air-weld side seams and end laps to ensure a watertight installation.
- E. Terminate and seal top of flashings and mechanically anchor to substrate through termination bars.

3.7 FIELD QUALITY CONTROL

- A. Final Roof Inspection: Arrange for roofing system manufacturer's technical personnel to inspect roofing installation on completion, in presence of Architect, and to prepare inspection report.
 - 1. Notify Architect 48 hours in advance of date and time of inspection.
- B. Repair or remove and replace components of roofing system where inspections indicate that they do not comply with specified requirements.
- C. Additional testing and inspecting, at Contractor's expense, will be performed to determine if replaced or additional work complies with specified requirements.
 - 1. Roofing system will be considered defective if it does not pass tests and inspections.
- D. Prepare test and inspection reports.

3.8 PROTECTING AND CLEANING

- A. Protect roofing system from damage and wear during remainder of construction period. When remaining construction does not affect or endanger roofing system, inspect roofing system for deterioration and damage, describing its nature and extent in a written report, with copies to Architect and Owner.
- B. Correct deficiencies in or remove roofing system that does not comply with requirements, repair substrates, and repair or reinstall roofing system to a condition free of damage and deterioration at time of Substantial Completion and according to warranty requirements.
- C. Clean overspray and spillage from adjacent construction using cleaning agents and

procedures recommended by manufacturer of affected construction.

3.9 ROOFING SYSTEM INSTALLER'S WARRANTY

- A. WHEREAS _____ of _____, herein called the "Roofing System Installer," has performed roofing and associated Work on the following Project:
1. Owner: <City of Kalamazoo - Crosstown>.
 2. Owner Address: <.>.
 3. Building Name/Type: <Insert information>.
 4. Building Address: <Insert address>.
 5. Area of Work: <Insert information>.
 6. Warranty Period: [~~Two~~][~~Five~~]<Insert number> years from date of Substantial Completion.
 7. Date of Substantial Completion: _____.
- B. AND WHEREAS Roofing System Installer has contracted (either directly with Owner or indirectly as a subcontractor) to warrant said Work against leaks and faulty or defective materials and workmanship for designated Warranty Period,
- C. NOW THEREFORE Roofing System Installer hereby warrants, subject to terms and conditions herein set forth, that during Warranty Period, Roofing System Installer will, at Roofing System Installer's own cost and expense, make or cause to be made such repairs to or replacements of said Work as are necessary to correct faulty and defective work and as are necessary to maintain said Work in a watertight condition.
- D. This Warranty is made subject to the following terms and conditions:
1. Specifically excluded from this Warranty are damages to Work and other parts of the building, and to building contents, caused by:
 - a. lightning;
 - b. peak gust wind speed exceeding **Insert**;
 - c. fire;
 - d. failure of roofing system substrate, including cracking, settlement, excessive deflection, deterioration, and decomposition;
 - e. faulty construction of parapet walls, copings, chimneys, skylights, vents, equipment supports, and other edge conditions and penetrations of the Work;
 - f. vapor condensation on bottom of roofing; and
 - g. activity on roofing by others, including construction contractors, maintenance personnel, other persons, and animals, whether authorized or unauthorized by Owner.
 2. When Work has been damaged by any of foregoing causes, Warranty will be null and void until such damage has been repaired by Roofing System Installer and until cost and expense thereof have been paid by Owner or by another responsible party so designated.
 3. Roofing System Installer is responsible for damage to Work covered by this

Warranty but is not liable for consequential damages to building or building contents resulting from leaks or faults or defects of Work.

4. During Warranty Period, if Owner allows alteration of Work by anyone other than Roofing System Installer, including cutting, patching, and maintenance in connection with penetrations, attachment of other work, and positioning of anything on roof, this Warranty will become null and void on date of said alterations, but only to the extent said alterations affect Work covered by this Warranty. If Owner engages Roofing System Installer to perform said alterations, Warranty will not become null and void unless Roofing System Installer, before starting said Work, will have notified Owner in writing, showing reasonable cause for claim, that said alterations would likely damage or deteriorate Work, thereby reasonably justifying a limitation or termination of this Warranty.
5. During Warranty Period, if original use of roof is changed and it becomes used for, but was not originally specified for, a promenade, work deck, spray-cooled surface, flooded basin, or other use or service more severe than originally specified, this Warranty will become null and void on date of said change, but only to the extent said change affects Work covered by this Warranty.
6. Owner will promptly notify Roofing System Installer of observed, known, or suspected leaks, defects, or deterioration and afford reasonable opportunity for Roofing System Installer to inspect Work and to examine evidence of such leaks, defects, or deterioration.
7. This Warranty is recognized to be the only warranty of Roofing System Installer on said Work and will not operate to restrict or cut off Owner from other remedies and resources lawfully available to Owner in cases of roofing failure. Specifically, this Warranty will not operate to relieve Roofing System Installer of responsibility for performance of original Work in accordance with requirements of the Contract Documents, regardless of whether Contract was a contract directly with Owner or a subcontract with Owner's General Contractor.

E. IN WITNESS THEREOF, this instrument has been duly executed this _____ day of _____, _____.

1. Authorized Signature: _____.
2. Name: _____.
3. Title: _____.

END OF SECTION 075423

SECTION 077100 - ROOF SPECIALTIES

PART 1 - GENERAL

1.1 SUMMARY

- A. Section Includes: Manufactured units for the following applications:
 - 1. Copings.
 - 2. Roof-edge specialties.
 - 3. Roof-edge drainage systems.
 - 4. Reglets and counterflashings.
 - 5. Underlayment.
- B. Related Requirements:
 - 1. Section 055000 "Metal Fabrications" for downspout guards and downspout boots.
 - 2. Section 061000 "Rough Carpentry" for wood nailers, curbs, and blocking.
 - 3. Section 07 2715 "Non-Bituminous Self-Adhering Sheet Air Barrier" for air barrier and compatibility with and transitions to underlayment for roof specialties.
 - 4. Section 079200 "Joint Sealants" for field-applied sealants between roof specialties and adjacent materials.

1.2 ACTION SUBMITTALS

1.3 INFORMATIONAL SUBMITTALS

- A. Roofing-System Warranty: Roof specialties are included in warranty provisions in Section 07 5423 "TPO Roofing."

PART 2 - PRODUCTS

2.1 PERFORMANCE REQUIREMENTS

- A. General Performance: Roof specialties to withstand exposure to weather and resist thermally induced movement without failure, rattling, leaking, or fastener disengagement due to defective manufacture, fabrication, installation, or other defects in construction.
- B. SPRI Wind Design Standard: Manufacture and install copings roof-edge specialties tested in accordance with ANSI/SPRI/FM 4435/ES-1 and capable of resisting the following design pressures:
 - 1. Design Pressure: As indicated on Drawings.

- C. Thermal Movements: Allow for thermal movements from ambient and surface temperature changes to prevent buckling, opening of joints, hole elongation, overstressing of components, failure of joint sealants, failure of connections, and other detrimental effects. Provide clips that resist rotation and avoid shear stress as a result of thermal movements. Base calculations on surface temperatures of materials due to both solar heat gain and nighttime-sky heat loss.
1. Temperature Change: 120 deg F, ambient; 180 deg F, material surfaces.
 2. Exposed Coil-Coated Finish: Prepainted by the coil-coating process to comply with ASTM A755/A755M. Prepare, pretreat, and apply coating to exposed metal surfaces to comply with coating and resin manufacturers' written instructions.
 - a. Two-Coat Fluoropolymer Finish: AAMA 2605. System consisting of primer and fluoropolymer color topcoat containing not less than 70 percent PVDF resin by weight in color coat.

2.2 GENERAL FINISH REQUIREMENTS

- A. Comply with NAAMM/NOMMA AMP 500, "Metal Finishes Manual for Architectural and Metal Products," for recommendations for applying and designating finishes.
- B. Protect mechanical and painted finishes on exposed surfaces from damage by applying a strippable, temporary protective covering before shipping.
- C. Appearance of Finished Work: Noticeable variations in same piece are unacceptable. Variations in appearance of adjoining components are acceptable if they are within the range of approved Samples and are assembled or installed to minimize contrast.

PART 3 - EXECUTION (Not Used)

END OF SECTION 077100

SECTION 078413 - PENETRATION FIRESTOPPING

PART 1 - GENERAL

1.1 SUMMARY

- A. Section Includes: Penetration firestopping systems.
 - 1. Penetration firestopping systems in fire-resistance-rated walls.
 - 2. Penetration firestopping systems in horizontal assemblies.
 - 3. Penetration firestopping systems in smoke barriers.
 - 4. Exposed penetration firestopping systems.
- B. Related Requirements:
 - 1. Section 078443 "Joint Firestopping" for joints in or between fire-resistance-rated construction, at exterior curtain-wall/floor intersections, and in smoke barriers.
 - 2. Section 079200 "Joint Sealants" for non-fire-resistance-rated joint sealants.

1.2 ACTION SUBMITTALS

- A. Product Data: For each type of product.
- B. Product Schedule: For each penetration firestopping system. Include location, illustration of firestopping system, and design designation of qualified testing and inspecting agency.

1.3 INFORMATIONAL SUBMITTALS

- A. Qualification Data: For Installer.
- B. Listed System Designs: For each penetration firestopping system, for tests performed by a qualified testing agency.

1.4 CLOSEOUT SUBMITTALS

- A. Installer Certificates: From Installer indicating that penetration firestopping systems have been installed in compliance with requirements and manufacturer's written instructions.

1.5 QUALITY ASSURANCE

- A. Manufacturer Qualifications: Entity that has received UL Solutions' "Firestop Movement Certification," which demonstrates that manufacturer's firestopping products

designated with M-Ratings are based on exposure to cyclic movement and UL 1479 fire test evaluation when tested in accordance with ASTM E3037.

1.6 FIELD CONDITIONS

- A. Environmental Limitations: Do not install penetration firestopping systems when ambient or substrate temperatures are outside limits permitted by penetration firestopping system manufacturers or when substrates are wet because of rain, frost, condensation, or other causes.
- B. Install and cure penetration firestopping system materials in accordance with manufacturer's written instructions using natural means of ventilations or, where this is inadequate, forced-air circulation.

PART 2 - PRODUCTS

2.1 ACCESSORIES

- A. Provide components for each penetration firestopping system that are needed to install fill materials and to maintain ratings required. Use only those components specified by penetration firestopping system manufacturer and approved by qualified testing and inspecting agency for conditions indicated, including but not limited to:
 - 1. Permanent forming/damming/backing materials.
 - 2. Substrate primers.
 - 3. Collars.
 - 4. Steel sleeves.

2.2 FILL MATERIALS

- A. Cast-in-Place Firestopping Devices: Factory-assembled devices for use in cast-in-place concrete floors and consisting of an outer sleeve lined with an intumescent strip, a flange attached to one end of the sleeve for fastening to concrete formwork, and a neoprene gasket.
- B. Latex Sealants: Single-component latex formulations that do not re-emulsify after cure during exposure to moisture.
- C. Firestopping Devices: Factory-assembled collars formed from galvanized steel and lined with intumescent material sized to fit specific diameter of penetrant.
- D. Intumescent Composite Sheets: Rigid panels consisting of aluminum-foil-faced intumescent elastomeric sheet bonded to galvanized-steel sheet.
- E. Intumescent Putties: Nonhardening, water-resistant, intumescent putties containing no solvents or inorganic fibers.

- F. Intumescent Wrap Strips: Single-component intumescent elastomeric strips for use around combustible penetrants.
- G. Mortars: Prepackaged dry mixes consisting of a blend of inorganic binders, hydraulic cement, fillers and lightweight aggregate formulated for mixing with water at Project site to form a nonshrinking, homogeneous mortar.
- H. Pillows/Bags: Compressible, removable, and reusable intumescent pillows encased in fire-retardant polyester or glass-fiber cloth. Where exposed, and when required by a listed system, cover openings with steel-reinforcing wire mesh to protect pillows/bags from being easily removed or dislodged.
- I. Silicone Foams: Multicomponent, silicone-based liquid elastomers that, when mixed, expand and cure in place to produce a flexible, nonshrinking foam.
- J. Silicone Sealants: Single-component, silicone-based, neutral-curing elastomeric sealants.
- K. Thermal and Endothermic Wraps: Flexible, insulating, and fire-resistant protective wraps tested and listed for up to 2-hour fire ratings in accordance with ASTM E814 or UL 1479; for protecting membrane penetrations of utility boxes, critical electrical circuits, communications lines, and fuel lines, and for thermal barrier and circuit integrity protection in accordance with ASTM E1725 or UL 1724.
- L. Fire-Rated Cable Sleeve Kits: Complete kits designed for new or existing cable penetrations through walls which accept standard accessories.
- M. Fire-Rated Cable Pathways: Single or gangable device modules composed of a steel raceway with integral intumescent material and requiring no additional action in the form of plugs, twisting closure, putty, pillows, sealant, or otherwise to achieve fire and air-leakage ratings.
 - 1. Fire-rated cable pathway devices are the preferred product for data, video, and communications cable penetrations. Install these devices in locations where frequent cable moves, add-ons, and changes will occur. Such devices must be:
 - a. Capable of retrofit around existing cables.
 - b. Designed so that two or more devices can be ganged together.
 - c. Maintenance-free so no action is required to activate the smoke- and fire-sealing mechanism.
 - 2. Where fire-rated cable pathway devices are not practical, openings within walls and floors designed to accommodate data, video, and communications cabling must be provided with re-enterable products specifically designed for retrofit, such as retrofit devices for cable bundles, firestopping putty, plugs, or pillows.
- N. Retrofit Device for Cable Bundles: Factory-made, intumescent, collar-like device for firestopping existing over-filled cable sleeves and capable of being installed around projecting sleeves and cable bundles.
- O. Wall-Opening Protective Materials: Intumescent, non-curing putty pads or self-

adhesive inserts for protection of electrical switch and receptacle boxes.

- P. Fire-Rated HVAC Retaining Angles: Steel angle system with integral intumescent firestopping gasket for use around rectangular steel HVAC ducts without fire dampers.
- Q. Firestopping Plugs: Flexible, re-enterable, intumescent, foam-rubber plug for use in blank round openings and cable sleeves.
- R. Fire-Rated Cable Grommet: Molded two-piece grommet made of plenum-grade polymer and foam inner core for sealing small cable penetrations in gypsum walls up to **1/2 inch** in diameter.
- S. Closet Flange Gasket: Molded, single-component, flexible, intumescent gasket for use beneath a water closet (toilet) flange in floor applications.

PART 3 - EXECUTION

3.1 FIELD QUALITY CONTROL

- A. Owner will engage a qualified inspection agency to conduct and report on inspections in accordance with ASTM E2174.
- B. Where deficiencies are found or penetration firestopping system is damaged or removed because of testing, repair or replace penetration firestopping system to comply with requirements.
- C. Proceed with enclosing penetration firestopping systems with other construction only after inspection reports are issued and installations comply with requirements.

END OF SECTION 078413

SECTION 078443 - JOINT FIRESTOPPING

PART 1 - GENERAL

1.1 SUMMARY

A. Related Requirements:

1. Section 078413 "Penetration Firestopping" for penetrations in fire-resistance-rated walls, horizontal assemblies, and smoke barriers.
2. Section 092216 "Non-Structural Metal Framing" for firestop tracks for metal-framed partition heads.

1.2 ACTION SUBMITTALS

A. Product Data:

1. For each type of product.

B. Product Schedule: For each joint firestopping system. Include location, illustration of firestopping system, and design designation of qualified testing agency.

1.3 INFORMATIONAL SUBMITTALS

A. Qualification Data: For Installer.

B. Listed System Designs: For each joint firestopping system, for tests performed by a qualified testing agency.

1.4 CLOSEOUT SUBMITTALS

A. Installer Certificates: From Installer indicating that joint firestopping systems have been installed in compliance with requirements and manufacturer's written installation instructions.

1.5 QUALITY ASSURANCE

A. Installer Qualifications: A firm that has been approved by FM Approvals in accordance with FM Approvals 4991 or been evaluated by UL and found to comply with UL's "UL Solutions Qualified Firestop Contractor Program."

1.6 FIELD CONDITIONS

- A. Environmental Limitations: Do not install joint firestopping systems when ambient or substrate temperatures are outside limits permitted by joint firestopping system manufacturers or when substrates are wet due to rain, frost, condensation, or other causes.
- B. Install and cure joint firestopping systems in accordance with manufacturer's written installation instructions using natural means of ventilation or, where this is inadequate, forced-air circulation.

PART 2 - PRODUCTS

2.1 ACCESSORIES

- A. Provide components of joint firestopping systems, including primers and forming materials, that are needed to install elastomeric fill materials and to maintain ratings required. Use only components specified by joint firestopping system manufacturer and approved by the qualified testing agency for conditions indicated.

PART 3 - EXECUTION

3.1 INSTALLATION

- A. General: Install joint firestopping systems in accordance with manufacturer's written installation instructions and published drawings for products and applications indicated.
- B. Install forming materials and other accessories of types required to support elastomeric fill materials during their application and in position needed to produce cross-sectional shapes and depths required to achieve fire ratings indicated.
 - 1. After installing elastomeric fill materials and allowing them to fully cure, remove combustible forming materials and other accessories not indicated as permanent components of fire-resistive joint system.
- C. Install elastomeric fill materials for joint firestopping systems by proven techniques to produce the following results:
 - 1. Apply elastomeric fill in voids and cavities formed by joints and forming materials as required to achieve fire-resistance ratings indicated.
 - 2. Apply elastomeric fill materials so they contact and adhere to substrates formed by joints.
 - 3. For elastomeric fill materials that will remain exposed after completing the Work, finish to produce smooth, uniform surfaces that are flush with adjoining finishes.

3.2 JOINT FIRESTOPPING SYSTEM SCHEDULE

- A. Where UL-classified systems are indicated, they refer to system numbers in UL's online directory "Product iQ" under product Category XHBN.

END OF SECTION 078443

SECTION 079200 - JOINT SEALANTS

PART 1 - GENERAL

1.1 SUMMARY

A. Section Includes:

1. Silicone joint sealants.
2. Nonstaining silicone joint sealants.
3. Mildew-resistant joint sealants.
4. Butyl joint sealants.
5. Latex joint sealants.

B. Related Requirements:

1. Section 079100 "Preformed Joint Seals" for preformed compressible foam and precured joint seals.
2. Section 079219 "Acoustical Joint Sealants" for sealing joints in sound-rated construction.

1.2 PREINSTALLATION MEETINGS

- A. Preinstallation Conference: Conduct conference at Project site.

1.3 ACTION SUBMITTALS

A. Product Data:

1. Silicone joint sealants.
2. Nonstaining silicone joint sealants.
3. Urethane joint sealants.
4. Mildew-resistant joint sealants.
5. Latex joint sealants.

- B. Samples for Verification: For each type and color of joint sealant required, provide Samples with joint sealants in **1/2-inch-** wide joints formed between two **6-inch-** long strips of material matching the appearance of exposed surfaces adjacent to joint sealants.

C. Joint-Sealant Schedule: Include the following information:

1. Joint-sealant application, joint location, and designation.
2. Joint-sealant manufacturer and product name.
3. Joint-sealant formulation.
4. Joint-sealant color.

1.4 INFORMATIONAL SUBMITTALS

- A. Sample warranties.

1.5 CLOSEOUT SUBMITTALS

- A. Manufacturers' special warranties.
- B. Installer's special warranties.

1.6 QUALITY ASSURANCE

- A. Installer Qualifications: Authorized representative who is trained and approved by manufacturer.
- B. Testing Agency Qualifications: Qualified in accordance with ASTM C1021 to conduct the testing indicated.

1.7 FIELD CONDITIONS

- A. Do not proceed with installation of joint sealants under the following conditions:
 - 1. When ambient and substrate temperature conditions are outside limits permitted by joint-sealant manufacturer or are below 40 deg F.
 - 2. When joint substrates are wet.
 - 3. Where joint widths are less than those allowed by joint-sealant manufacturer for applications indicated.
 - 4. Where contaminants capable of interfering with adhesion have not yet been removed from joint substrates.

1.8 WARRANTY

- A. Special Installer's Warranty: Installer agrees to repair or replace joint sealants that do not comply with performance and other requirements specified in this Section within specified warranty period.
 - 1. Warranty Period: Two years from date of Substantial Completion.
- B. Special Manufacturer's Warranty: Manufacturer agrees to furnish joint sealants to repair or replace those joint sealants that do not comply with performance and other requirements specified in this Section within specified warranty period.
 - 1. Warranty Period: Five years from date of Substantial Completion.
- C. Special warranties specified in this article exclude deterioration or failure of joint sealants from the following:

1. Movement of the structure caused by stresses on the sealant exceeding sealant manufacturer's written specifications for sealant elongation and compression.
2. Disintegration of joint substrates from causes exceeding design specifications.
3. Mechanical damage caused by individuals, tools, or other outside agents.
4. Changes in sealant appearance caused by accumulation of dirt or other atmospheric contaminants.

PART 2 - PRODUCTS

2.1 JOINT SEALANTS, GENERAL

- A. **Compatibility:** Provide joint sealants, backings, and other related materials that are compatible with one another and with joint substrates under conditions of service and application, as demonstrated by joint-sealant manufacturer, based on testing and field experience.
- B. **Colors of Exposed Joint Sealants:** As selected by Architect from manufacturer's full range.

2.2 SILICONE JOINT SEALANTS

- A. **Silicone, S, NS, 100/50, NT:** Single-component, nonsag, plus 100 percent and minus 50 percent movement capability, nontraffic-use, neutral-curing silicone joint sealant; ASTM C920, Type S, Grade NS, Class 100/50, Use NT.
 1. **Manufacturers:** Subject to compliance with requirements, available manufacturers offering products that may be incorporated into the Work include, but are not limited to, the following:
 - a. Adfast
 - b. GE Construction Sealants; Momentive Performance Materials Inc.
 - c. Sika Corporation - Building Components

2.3 NONSTAINING SILICONE JOINT SEALANTS

- A. **Nonstaining Joint Sealants:** No staining of substrates when tested in accordance with ASTM C1248.
- B. **Silicone, Nonstaining, S, NS, 100/50, NT:** Nonstaining, single-component, nonsag, plus 100 percent and minus 50 percent movement capability, nontraffic-use, neutral-curing silicone joint sealant; ASTM C920, Type S, Grade NS, Class 100/50, Use NT.
 1. **Manufacturers:** Subject to compliance with requirements, available manufacturers offering products that may be incorporated into the Work include, but are not limited to, the following:
 - a. Adfast

- b. Pecora Corporation
 - c. Sika Corporation - Building Components
 - d. Tremco Incorporated
- C. Silicone, Nonstaining, S, NS, 50, NT: Nonstaining, single-component, nonsag, plus 50 percent and minus 50 percent movement capability, nontraffic-use, neutral-curing silicone joint sealant; ASTM C920, Type S, Grade NS, Class 50, Use NT.
- 1. Manufacturers: Subject to compliance with requirements, available manufacturers offering products that may be incorporated into the Work include, but are not limited to, the following:
 - a. Adfast
 - b. GE Construction Sealants; Momentive Performance Materials Inc.
 - c. Sika Corporation - Building Components
 - d. Tremco Incorporated

2.4 MILDEW-RESISTANT JOINT SEALANTS

- A. Mildew-Resistant Joint Sealants: Formulated for prolonged exposure to humidity with fungicide to prevent mold and mildew growth.
- B. Silicone, Mildew Resistant, Acid Curing, S, NS, 25, NT: Mildew-resistant, single-component, nonsag, plus 25 percent and minus 25 percent movement capability, nontraffic-use, acid-curing silicone joint sealant; ASTM C920, Type S, Grade NS, Class 25, Use NT.
- 1. Manufacturers: Subject to compliance with requirements, available manufacturers offering products that may be incorporated into the Work include, but are not limited to, the following:
 - a. Adfast
 - b. GE Construction Sealants; Momentive Performance Materials Inc.
 - c. Pecora Corporation
 - d. Sika Corporation - Building Components
 - e. Soudal Accumetric
 - f. The Dow Chemical Company
 - g. The Pittsburgh Paints Company
 - h. Tremco Incorporated

2.5 BUTYL JOINT SEALANTS

- A. Butyl-Rubber-Based Joint Sealants: ASTM C1311.
- 1. Manufacturers: Subject to compliance with requirements, available manufacturers offering products that may be incorporated into the Work include, but are not limited to, the following:
 - a. Bostik; Arkema

- b. Everkem Diversified Products, Inc.
- c. GSSI Sealants
- d. Pecora Corporation
- e. Sika Corporation - Building Components

2.6 LATEX JOINT SEALANTS

- A. Acrylic Latex: Acrylic latex or siliconized acrylic latex, ASTM C834, Type OP, Grade NF.
 - 1. Manufacturers: Subject to compliance with requirements, available manufacturers offering products that may be incorporated into the Work include, but are not limited to, the following:
 - a. Adfast
 - b. Everkem Diversified Products, Inc.
 - c. Franklin International
 - d. Pecora Corporation
 - e. Sherwin-Williams Company (The)
 - f. The Pittsburgh Paints Company
 - g. Tremco Incorporated

2.7 JOINT-SEALANT BACKING

- A. Sealant Backing Material: Nonstaining; compatible with joint substrates, sealants, primers, and other joint fillers; and approved for applications indicated by sealant manufacturer based on field experience and laboratory testing.
 - 1. Manufacturers: Subject to compliance with requirements, available manufacturers offering products that may be incorporated into the Work include, but are not limited to, the following:
 - a. Adfast
 - b. Alcot Plastics Ltd.
 - c. Construction Foam Products; a division of Nomaco, Inc.
- B. Cylindrical Sealant Backings: ASTM C1330, Type C (closed-cell material with a surface skin) Type O (open-cell material) Type B (bicellular material with a surface skin), and of size and density to control sealant depth and otherwise contribute to producing optimum sealant performance.
- C. Bond-Breaker Tape: Polyethylene tape or other plastic tape recommended by sealant manufacturer for preventing sealant from adhering to rigid, inflexible joint-filler materials or joint surfaces at back of joint. Provide self-adhesive tape where applicable.

2.8 MISCELLANEOUS MATERIALS

- A. Cleaners for Nonporous Surfaces: Chemical cleaners acceptable to manufacturers of

sealants and sealant backing materials, free of oily residues or other substances capable of staining or harming joint substrates and adjacent nonporous surfaces in any way, and formulated to promote optimum adhesion of sealants to joint substrates.

- B. Masking Tape: Nonstaining, nonabsorbent material compatible with joint sealants and surfaces adjacent to joints.

PART 3 - EXECUTION

3.1 EXAMINATION

- A. Examine joints indicated to receive joint sealants, with Installer present, for compliance with requirements for joint configuration, installation tolerances, and other conditions affecting performance of the Work.
- B. Proceed with installation only after unsatisfactory conditions have been corrected.

3.2 PREPARATION

- A. Surface Cleaning of Joints: Clean out joints immediately before installing joint sealants to comply with joint-sealant manufacturer's written instructions and the following requirements:
 - 1. Remove all foreign material from joint substrates that could interfere with adhesion of joint sealant, including dust, paints (except for permanent, protective coatings tested and approved for sealant adhesion and compatibility by sealant manufacturer), old joint sealants, oil, grease, waterproofing, water repellents, water, surface dirt, and frost.
 - 2. Clean porous joint substrate surfaces by brushing, grinding, mechanical abrading, or a combination of these methods to produce a clean, sound substrate capable of developing optimum bond with joint sealants. Remove loose particles remaining after cleaning operations above by vacuuming or blowing out joints with oil-free compressed air. Porous joint substrates include the following:
 - a. Concrete.
 - b. Masonry.
 - c. Unglazed surfaces of ceramic tile.
 - d. Exterior insulation and finish systems.
 - 3. Remove laitance and form-release agents from concrete.
 - 4. Clean nonporous joint substrate surfaces with chemical cleaners or other means that do not stain, harm substrates, or leave residues capable of interfering with adhesion of joint sealants. Nonporous joint substrates include the following:
 - a. Metal.
 - b. Glass.
 - c. Glazed surfaces of ceramic tile.

- B. Joint Priming: Prime joint substrates where recommended by joint-sealant manufacturer or as indicated by preconstruction joint-sealant-substrate tests or prior experience. Apply primer to comply with joint-sealant manufacturer's written instructions. Confine primers to areas of joint-sealant bond; do not allow spillage or migration onto adjoining surfaces.
- C. Masking Tape: Use masking tape where required to prevent contact of sealant or primer with adjoining surfaces that otherwise would be permanently stained or damaged by such contact or by cleaning methods required to remove sealant smears. Remove tape immediately after tooling without disturbing joint seal.

3.3 INSTALLATION OF JOINT SEALANTS

- A. General: Comply with joint-sealant manufacturer's written installation instructions for products and applications indicated, unless more stringent requirements apply.
- B. Sealant Installation Standard: Comply with recommendations in ASTM C1193 for use of joint sealants as applicable to materials, applications, and conditions indicated.
- C. Install sealant backings of type indicated to support sealants during application and at position required to produce cross-sectional shapes and depths of installed sealants relative to joint widths that allow optimum sealant movement capability.
 - 1. Do not leave gaps between ends of sealant backings.
 - 2. Do not stretch, twist, puncture, or tear sealant backings.
 - 3. Remove absorbent sealant backings that have become wet before sealant application, and replace them with dry materials.
- D. Install bond-breaker tape behind sealants where sealant backings are not used between sealants and backs of joints.
- E. Install sealants using proven techniques that comply with the following and at the same time backings are installed:
 - 1. Place sealants so they directly contact and fully wet joint substrates.
 - 2. Completely fill recesses in each joint configuration.
 - 3. Produce uniform, cross-sectional shapes and depths relative to joint widths that allow optimum sealant movement capability.
- F. Tooling of Nonsag Sealants: Immediately after sealant application and before skinning or curing begins, tool sealants in accordance with requirements specified in subparagraphs below to form smooth, uniform beads of configuration indicated; to eliminate air pockets; and to ensure contact and adhesion of sealant with sides of joint.
 - 1. Remove excess sealant from surfaces adjacent to joints.
 - 2. Use tooling agents that are approved in writing by sealant manufacturer and that do not discolor sealants or adjacent surfaces.
 - 3. Provide concave joint profile in accordance with Figure 8A in ASTM C1193 unless otherwise indicated.

3.4 CLEANING

- A. Clean off excess sealant or sealant smears adjacent to joints as the Work progresses by methods and with cleaning materials approved in writing by manufacturers of joint sealants and of products in which joints occur.

3.5 PROTECTION

- A. Protect joint sealants during and after curing period from contact with contaminating substances and from damage resulting from construction operations or other causes so sealants are without deterioration or damage at time of Substantial Completion. If, despite such protection, damage or deterioration occurs, cut out, remove, and repair damaged or deteriorated joint sealants immediately so installations with repaired areas are indistinguishable from original work.

END OF SECTION 079200

SECTION 079219 - ACOUSTICAL JOINT SEALANTS

PART 1 - GENERAL

1.1 SUMMARY

- A. Section Includes: Acoustical joint sealants.
- B. Related Requirements:
 - 1. Section 079200 "Joint Sealants" for elastomeric, latex, and butyl-rubber-based joint sealants for nonacoustical applications.

1.2 ACTION SUBMITTALS

- A. Product Data: For each type of product.
- B. Acoustical Joint-Sealant Schedule: Include the following information:
 - 1. Joint-sealant application, joint location, and designation.
 - 2. Joint-sealant manufacturer and product name.
 - 3. Joint-sealant formulation.
 - 4. Joint-sealant color.

1.3 INFORMATIONAL SUBMITTALS

- A. Test and Evaluation Reports:
 - 1. Product Test Reports: For each type of acoustical joint sealant, for tests performed by qualified testing agency.
- B. Sample warranties.

1.4 CLOSEOUT SUBMITTALS

- A. Warranty Documentation:
 - 1. Manufacturers' special warranties.
 - 2. Installer's special warranties.

1.5 WARRANTY

- A. Installer's Special Warranty: Installer agrees to repair or replace acoustical joint sealants that do not comply with performance and other requirements specified in this

Section within specified warranty period.

1. Warranty Period: Two years from date of Substantial Completion.

PART 2 - PRODUCTS

2.1 ACOUSTICAL JOINT SEALANTS

- A. Acoustical joint-sealant products that effectively reduce airborne sound transmission through perimeter joints and openings in building construction, as demonstrated by testing representative assemblies in accordance with ASTM E90.
 1. Sealant shall have a VOC content of 250 g/L or less.
 2. Sealant shall comply with the testing and product requirements of the California Department of Public Health's "Standard Method for the Testing and Evaluation of Volatile Organic Chemical Emissions from Indoor Sources Using Environmental Chambers."
 3. Sealant shall comply with the testing and product requirements of the California Department of Public Health's "Standard Method for the Testing and Evaluation of Volatile Organic Chemical Emissions from Indoor Sources Using Environmental Chambers." Formaldehyde emissions shall not exceed 9 mcg/cu. m or 7 ppb, whichever is less.
 4. Sealant shall comply with the testing and product requirements of the California Department of Public Health's "Standard Method for the Testing and Evaluation of Volatile Organic Chemical Emissions from Indoor Sources Using Environmental Chambers." The building concentration of formaldehyde shall not exceed half of the indoor recommended exposure limit, or 33 mcg/cu. m, and that of acetaldehyde shall not exceed 9 mcg/cu. m.
- B. Acoustical Sealant for Exposed and Concealed Joints: Manufacturer's standard nonsag, paintable, nonstaining latex acoustical sealant complying with ASTM C834.
 1. Manufacturers: Subject to compliance with requirements, available manufacturers offering products that may be incorporated into the Work include, but are not limited to, the following:
 - a. DAP Products Inc.
 - b. Everkem Diversified Products, Inc.
 - c. Franklin International
 - d. Grabber Construction Products, Inc.
 - e. Hilti, Inc.
 - f. OSI Sealants; Henkel Corporation
 - g. Pecora Corporation
 - h. USG Corporation
 2. Colors of Exposed Acoustical Joint Sealants: As selected by Architect from manufacturer's full range of colors.
- C. Acoustical Sealant for Concealed Joints: Manufacturer's standard nonsag, nondrying,

nonhardening, nonskinning, nonstaining, gunnable, synthetic-rubber acoustical sealant.

1. Manufacturers: Subject to compliance with requirements, available manufacturers offering products that may be incorporated into the Work include, but are not limited to, the following:
 - a. OSI Sealants; Henkel Corporation
 - b. Pecora Corporation
 - c. Tremco Incorporated
 - d. USG Corporation

2.2 MISCELLANEOUS MATERIALS

- A. Primer: Material recommended by acoustical joint-sealant manufacturer where required for adhesion of sealant to joint substrates.
- B. Cleaners for Nonporous Surfaces: Chemical cleaners acceptable to manufacturers of sealants and sealant backing materials, free of oily residues or other substances capable of staining or harming joint substrates and adjacent nonporous surfaces in any way, and formulated to promote optimum adhesion of sealants to joint substrates.
- C. Masking Tape: Nonstaining, nonabsorbent material compatible with joint sealants and surfaces adjacent to joints.

PART 3 - EXECUTION

3.1 INSTALLATION OF ACOUSTICAL JOINT SEALANTS

- A. Comply with acoustical joint-sealant manufacturer's written installation instructions unless more stringent requirements apply.
- B. STC-Rated Assemblies: Seal construction at perimeters, behind control joints, and at openings and penetrations with a continuous bead of acoustical joint sealant. Install acoustical joint sealants at both faces of partitions, at perimeters, and through penetrations. Comply with ASTM C919, ASTM C1193, and manufacturer's written instructions for closing off sound-flanking paths around or through assemblies, including sealing partitions to underside of floor slabs above acoustical ceilings.
- C. Acoustical Ceiling Areas: Apply acoustical joint sealant at perimeter edge moldings of acoustical ceiling areas in a continuous ribbon concealed on back of vertical legs of moldings before they are installed.

END OF SECTION 079219

SECTION 081113 - HOLLOW METAL DOORS AND FRAMES

PART 1 - GENERAL

1.1 SUMMARY

A. Section Includes:

1. Interior standard steel doors and frames.

B. Related Requirements:

1. Section 087100 "Door Hardware" for door hardware for hollow-metal doors.

1.2 DEFINITIONS

- A. Minimum Thickness: Minimum thickness of base metal without coatings in accordance with NAAMM-HMMA 803 or ANSI/SDI A250.8.

1.3 COORDINATION

- A. Coordinate anchorage installation for hollow-metal frames. Furnish setting drawings, templates, and directions for installing anchorages, including sleeves, concrete inserts, anchor bolts, and items with integral anchors. Deliver such items to Project site in time for installation.
- B. Coordinate requirements for installation of door hardware, electrified door hardware, and access control and security systems.

1.4 ACTION SUBMITTALS

A. Product Data:

1. Interior standard steel doors and frames.

B. Product Data Submittals: For each product.

1. Include construction details, material descriptions, core descriptions, fire-resistance ratings, and finishes.

C. Shop Drawings: Include the following:

1. Elevations of each door type.
2. Details of doors, including vertical- and horizontal-edge details and metal thicknesses.

3. Frame details for each frame type, including dimensioned profiles and metal thicknesses.
 4. Locations of reinforcement and preparations for hardware.
 5. Details of each different wall opening condition.
 6. Details of electrical raceway and preparation for electrified hardware, access control systems, and security systems.
 7. Details of anchorages, joints, field splices, and connections.
 8. Details of accessories.
 9. Details of moldings, removable stops, and glazing.
- D. Samples for Initial Selection: For hollow-metal doors and frames with factory-applied color finishes.
- E. Product Schedule: For hollow-metal doors and frames, prepared by or under the supervision of supplier, using same reference numbers for details and openings as those on Drawings. Coordinate with final door hardware schedule.

1.5 INFORMATIONAL SUBMITTALS

- A. Qualification Data: For door inspector.
- B. Product Test Reports: For each type of fire-rated hollow-metal door and frame assembly fire-rated borrowed-lite assembly for tests performed by a qualified testing agency indicating compliance with performance requirements.
- C. Field quality-control reports.

1.6 CLOSEOUT SUBMITTALS

- A. Record Documents: For fire-rated doors, list of door numbers and applicable room name and number to which door accesses.

1.7 QUALITY ASSURANCE

- A. Fire-Rated Door Inspector Qualifications: Inspector for field quality-control inspections of fire-rated door assemblies is to meet the qualifications set forth in NFPA 80, Section 5.2.3.1 and the following:
- B. Egress Door Inspector Qualifications: Inspector for field quality-control inspections of egress door assemblies is to meet the qualifications set forth in NFPA 101, Section 7.2.1.15.4 and the following:

1.8 DELIVERY, STORAGE, AND HANDLING

- A. Deliver hollow-metal doors and frames palletized, packaged, or crated to provide protection during transit and Project-site storage. Do not use nonvented plastic.

1. Provide additional protection to prevent damage to factory-finished units.
- B. Deliver welded frames with two removable spreader bars across bottom of frames, tack welded to jambs and mullions.
- C. Store hollow-metal doors and frames vertically under cover at Project site with head up. Place on minimum **4-inch**- high wood blocking. Provide minimum **1/4-inch** space between each stacked door to permit air circulation.

PART 2 - PRODUCTS

2.1 HOLLOW METAL DOORS AND FRAMES

- A. Basis-of-Design Product: Subject to compliance with requirements, provide Curries, AADG, Inc.; ASSA ABLOY Group or comparable product by one of the following:
 1. Ceco Door; AADG, Inc.; ASSA ABLOY
 2. DCI Hollow Metal on Demand
 3. DE LA FONTAINE
 4. Deansteel Manufacturing Company, Inc.
 5. Hollow Metal Xpress
 6. Mesker Door; Mesker Openings Group
 7. MPI Group, LLC (The)
 8. Pioneer Industries; AADG, Inc.; ASSA ABLOY
 9. Premier Products, Inc
 10. Republic Doors and Frames; a Allegion brand
 11. Steelcraft; Allegion plc
 12. Stiles Custom Metal, Inc
 13. Titan Metal Products

2.2 PERFORMANCE REQUIREMENTS

- A. Fire-Rated Door Assemblies: Assemblies complying with NFPA 80 that are listed and labeled by a qualified testing agency acceptable to authorities having jurisdiction for fire-protection ratings indicated on Drawings, based on testing at positive pressure in accordance with NFPA 252 or UL 10C.
 1. Smoke- and Draft-Control Door Assemblies: Listed and labeled for smoke and draft control by a qualified testing agency acceptable to authorities having jurisdiction, based on testing in accordance with UL 1784 and installed in compliance with NFPA 105.
- B. Fire-Rated, Borrowed-Lite Assemblies: Assemblies complying with NFPA 80 and listed and labeled by a qualified testing agency acceptable to authorities having jurisdiction, for fire-protection ratings indicated, based on testing in accordance with NFPA 257 or UL 9.

2.3 INTERIOR STANDARD STEEL DOORS AND FRAMES

- A. Construct hollow-metal doors and frames to comply with standards indicated for materials, fabrication, hardware locations, hardware reinforcement, tolerances, and clearances, and as specified.
- B. Heavy-Duty Doors and Frames: ANSI/SDI A250.8, Level 2; ANSI/SDI A250.4, Level B. At locations indicated in the Door and Frame Schedule on Drawings.
 - 1. Doors:
 - a. Type: As indicated in the Door and Frame Schedule on Drawings.
 - b. Thickness: **1-3/4 inches**.
 - c. Face: Metallic-coated steel sheet, minimum thickness of **0.042 inch**.
 - d. Edge Construction: Model 2, Seamless.
 - e. Edge Bevel: Provide manufacturer's standard beveled or square edges.
 - f. Core: Manufacturer's standard.
 - g. Fire-Rated Core: Manufacturer's standard core for fire-rated doors.
 - 2. Frames:
 - a. Materials: Metallic-coated steel sheet, minimum thickness of **0.053 inch**.
 - b. Sidelite and Transom Frames: Fabricated from same thickness material as adjacent door frame.
 - c. Construction: Knocked down Full profile welded.
 - 3. Exposed Finish: Prime.

2.4 BORROWED LITES

- A. Fabricate of steel sheet, minimum thickness of **0.053 inch**.
- B. Construction: Knocked down Full profile welded. Construction to match adjacent frame.
- C. Fabricate in one piece except where handling and shipping limitations require multiple sections. Where frames are fabricated in sections due to shipping or handling limitations, provide alignment plates or angles at each joint, fabricated of metal of same or greater thickness as metal as frames.
- D. Provide countersunk, flat- or oval-head exposed screws and bolts for exposed fasteners unless otherwise indicated.

2.5 FRAME ANCHORS

- A. Jamb Anchors:
 - 1. Type: Anchors of minimum size and type required by applicable door and frame standard, and suitable for performance level indicated.
 - 2. Quantity: Minimum of three anchors per jamb, with one additional anchor for

frames with no floor anchor. Provide one additional anchor for each **24 inches** of frame height above **7 feet**.

3. Postinstalled Expansion Anchor: Minimum **3/8-inch-** diameter bolts with expansion shields or inserts, with manufacturer's standard pipe spacer.

B. Floor Anchors: Provide floor anchors for each jamb and mullion that extends to floor.

C. Material: ASTM A879/A879M, Commercial Steel (CS), **04Z** coating designation; mill phosphatized.

1. For anchors built into exterior walls, steel sheet complying with ASTM A1008/A1008M or ASTM A1011/A1011M; hot-dip galvanized in accordance with ASTM A153/A153M, Class B.

2.6 MATERIALS

A. Cold-Rolled Steel Sheet: ASTM A1008/A1008M, Commercial Steel (CS), Type B; suitable for exposed applications.

B. Hot-Rolled Steel Sheet: ASTM A1011/A1011M, Commercial Steel (CS), Type B; free of scale, pitting, or surface defects; pickled and oiled.

C. Metallic-Coated Steel Sheet: ASTM A653/A653M, Commercial Steel (CS), Type B.

D. Inserts, Bolts, and Fasteners: Hot-dip galvanized in accordance with ASTM A153/A153M.

E. Mineral-Fiber Insulation: ASTM C665, Type I (blankets without membrane facing); consisting of fibers manufactured from slag or rock wool; with maximum flame-spread and smoke-developed indexes of 25 and 50, respectively; passing ASTM E136 for combustion characteristics.

F. Glazing: Comply with requirements in Section 088000 "Glazing."

2.7 FABRICATION

A. Door Astragals: Provide overlapping astragal on one leaf of pairs of doors where required by NFPA 80 for fire-performance rating or where indicated. Extend minimum **3/4 inch** beyond edge of door on which astragal is mounted or as required to comply with published listing of qualified testing agency.

B. Hollow-Metal Frames: Fabricate in one piece except where handling and shipping limitations require multiple sections. Where frames are fabricated in sections, provide alignment plates or angles at each joint, fabricated of metal of same or greater thickness as frames.

1. Sidelite and Transom Bar Frames: Provide closed tubular members with no visible face seams or joints, fabricated from same material as door frame. Fasten members at crossings and to jambs by welding.

2. Provide countersunk, flat- or oval-head exposed screws and bolts for exposed fasteners unless otherwise indicated.
 3. Door Silencers: Except on weather-stripped frames, drill stops to receive door silencers as follows. Keep holes clear during construction.
 - a. Single-Door Frames: Drill stop in strike jamb to receive three door silencers.
 - b. Double-Door Frames: Drill stop in head jamb to receive two door silencers.
- C. Hardware Preparation: Factory prepare hollow-metal doors and frames to receive templated mortised hardware, and electrical wiring; include cutouts, reinforcement, mortising, drilling, and tapping in accordance with ANSI/SDI A250.6, the Door Hardware Schedule on Drawings, and templates.
1. Reinforce doors and frames to receive nontemplated, mortised, and surface-mounted door hardware.
 2. Comply with BHMA A156.115 for preparing hollow-metal doors and frames for hardware.
- D. Glazed Lites: Provide stops and moldings around glazed lites where indicated. Form corners of stops and moldings with butted or hairline joints.
1. Provide stops and moldings flush with face of door, and with beveled stops unless otherwise indicated.
 2. Multiple Glazed Lites: Provide fixed and removable stops and moldings so that each glazed lite is capable of being removed independently.
 3. Provide fixed frame moldings on outside of exterior and on secure side of interior doors and frames. Provide loose stops and moldings on inside of hollow-metal doors and frames.
 4. Coordinate rabbet width between fixed and removable stops with glazing and installation types indicated.
 5. Provide stops for installation with countersunk flat- or oval-head machine screws spaced uniformly not more than **9 inches** o.c. and not more than **2 inches** o.c. from each corner.

2.8 STEEL FINISHES

- A. Prime Finish: Clean, pretreat, and apply manufacturer's standard primer.
1. Shop Primer: Manufacturer's standard, fast-curing, lead- and chromate-free primer complying with ANSI/SDI A250.10; recommended by primer manufacturer for substrate; compatible with substrate and field-applied coatings despite prolonged exposure.

PART 3 - EXECUTION

3.1 PREPARATION

- A. Remove welded-in shipping spreaders installed at factory. Restore exposed finish by grinding, filling, and dressing, as required to make repaired area smooth, flush, and invisible on exposed faces. Touch up factory-applied finishes where spreaders are removed.
- B. Drill and tap doors and frames to receive nontemplated, mortised, and surface-mounted door hardware.

3.2 INSTALLATION

- A. Install hollow-metal doors and frames plumb, rigid, properly aligned, and securely fastened in place. Comply with approved Shop Drawings and with manufacturer's written instructions.
- B. Hollow-Metal Frames: Comply with ANSI/SDI A250.11 NAAMM-HMMA 840.
 - 1. Set frames accurately in position; plumbed, aligned, and braced securely until permanent anchors are set. After wall construction is complete, remove temporary braces without damage to completed Work.
 - a. Where frames are fabricated in sections, field splice at approved locations by welding face joint continuously; grind, fill, dress, and make splice smooth, flush, and invisible on exposed faces. Touch-up finishes.
 - b. Install frames with removable stops located on secure side of opening.
 - 2. Fire-Rated Openings: Install frames in accordance with NFPA 80.
 - 3. Floor Anchors: Secure with postinstalled expansion anchors.
 - 4. Solidly pack mineral-fiber insulation inside frames.
 - 5. Masonry Walls: Coordinate installation of frames to allow for solidly filling space between frames and masonry with grout or mortar.
 - 6. In-Place Concrete or Masonry Construction: Secure frames in place with postinstalled expansion anchors. Countersink anchors, and fill and make smooth, flush, and invisible on exposed faces.
 - 7. Installation Tolerances: Adjust hollow-metal frames to the following tolerances:
 - a. Squareness: Plus or minus **1/16 inch**, measured at door rabbet on a line 90 degrees from jamb perpendicular to frame head.
 - b. Alignment: Plus or minus **1/16 inch**, measured at jambs on a horizontal line parallel to plane of wall.
 - c. Twist: Plus or minus **1/16 inch**, measured at opposite face corners of jambs on parallel lines, and perpendicular to plane of wall.
 - d. Plumbness: Plus or minus **1/16 inch**, measured at jambs at floor.
- C. Hollow-Metal Doors: Fit and adjust hollow-metal doors accurately in frames, within clearances specified below.

1. Non-Fire-Rated Steel Doors: Comply with ANSI/SDI A250.8.
2. Fire-Rated Doors: Install doors with clearances in accordance with NFPA 80.

D. Glazing: Comply with installation requirements in Section 088000 "Glazing" and with hollow-metal manufacturer's written instructions.

3.3 REPAIR

- A. Prime-Coat Touchup: Immediately after erection, sand smooth rusted or damaged areas of prime coat and apply touchup of compatible air-drying, rust-inhibitive primer.
- B. Metallic-Coated Surface Touchup: Clean abraded areas and repair with galvanizing repair paint in accordance with manufacturer's written instructions.
- C. Touchup Painting: Cleaning and touchup painting of abraded areas of paint are specified in painting Sections.

END OF SECTION 081113

SECTION 081416 - FLUSH WOOD DOORS

PART 1 - GENERAL

1.1 SUMMARY

A. Section Includes:

1. Solid-core five-ply flush wood veneer-faced doors and transom panels for transparent finish.

1.2 ACTION SUBMITTALS

A. Product Data:

1. Solid-core five-ply flush wood veneer-faced doors and transom panels for transparent finish.

B. Product Data Submittals: For each product, including the following:

1. Door core materials and construction.
2. Door edge construction
3. Door face type and characteristics.
4. Factory-machining criteria.

C. Shop Drawings: Indicate location, size, and hand of each door; elevation of each type of door; construction details not covered in Product Data; and the following:

1. Door schedule indicating door location, type, size, fire protection rating, and swing.
2. Door elevations, dimension and locations of hardware, lite and louver cutouts, and glazing thicknesses.
3. Details of frame for each frame type, including dimensions and profile.
4. Details of electrical raceway and preparation for electrified hardware, access control systems, and security systems.
5. Dimensions and locations of blocking for hardware attachment.
6. Dimensions and locations of mortises and holes for hardware.
7. Clearances and undercuts.
8. Requirements for veneer matching.
9. Doors to be factory finished and application requirements.
10. Apply Program label to Shop Drawings.

D. Samples for Verification:

1. Factory finishes applied to actual door face materials, approximately **8 by 10 inches**, for each material and finish.
2. Polymer edging, in manufacturer's standard colors.

1.3 INFORMATIONAL SUBMITTALS

- A. Qualification Data: For door inspector.
- B. Field quality-control reports.

1.4 CLOSEOUT SUBMITTALS

- A. Special warranties.

1.5 QUALITY ASSURANCE

- A. Manufacturer's Certification: Licensed participant in AWI's Quality Certification Program WI's Certified Compliance Program.
- B. Fire-Rated Door Inspector Qualifications: Inspector for field quality-control inspections of fire-rated door assemblies complies with qualifications set forth in NFPA 80, Section 5.2.3.1 and the following:
 - 1. DHI's Fire and Egress Door Assembly Inspector (FDAI) certification.
- C. Egress Door Inspector Qualifications: Inspector for field quality-control inspections of egress door assemblies complies with qualifications set forth in NFPA 101, Section 7.2.1.15.4 and the following:
 - 1. DHI's Fire and Egress Door Assembly Inspector (FDAI) certification.

1.6 DELIVERY, STORAGE, AND HANDLING

- A. Comply with requirements of referenced standard and manufacturer's written instructions.

1.7 FIELD CONDITIONS

- A. Environmental Limitations:
 - 1. Do not deliver or install doors until spaces are enclosed and weathertight, wet-work in spaces is complete and dry, and HVAC system is operating and maintaining temperature and relative humidity at levels designed for building occupants for the remainder of construction period.
 - 2. Do not deliver or install doors until building is enclosed and weathertight, wet work is complete, and HVAC system is operating and maintaining temperature between **60 and 90 deg F** and relative humidity between 25 and 55 percent during remainder of construction period.

1.8 WARRANTY

- A. Special Warranty: Manufacturer agrees to repair or replace doors and frames that fail in materials or workmanship within specified warranty period.
 - 1. Failures include, but are not limited to, the following:
 - a. Delamination of veneer.
 - b. Warping (bow, cup, or twist) more than **1/4 inch** in a **42-by-84-inch** section.
 - c. Telegraphing of core construction in face veneers exceeding **0.01 inch in a 3-inch** span.
 - 2. Warranty also includes installation and finishing that may be required due to repair or replacement of defective doors and frames.
 - 3. Warranty Period for Solid-Core Interior Doors: Life of installation.

PART 2 - PRODUCTS

2.1 SOURCE LIMITATIONS

- A. Obtain flush wood doors from single manufacturer.

2.2 FLUSH WOOD DOORS AND FRAMES, GENERAL

- A. Quality Standard: In addition to requirements specified, comply with AWI/AWMAC/WI's "Architectural Woodwork Standards."
 - 1. Provide labels and certificates from AWI certification program indicating that doors and frames comply with requirements of grades specified.

2.3 SOLID-CORE FIVE-PLY FLUSH WOOD VENEER-FACED DOORS AND TRANSOM PANELS FOR TRANSPARENT FINISH

- A. Interior Doors, Solid-Core Five-Ply Veneer-Faced:
 - 1. Basis-of-Design Product: Subject to compliance with requirements, provide VT Industries or Approved Equivalent by one of the following:
 - a. Lambton Doors
 - b. Lynden Door, Inc.
 - c. Masonite Architectural
 - d. Oregon Door
 - e. Oshkosh Door Company
 - f. Wilsonart LLC
 - 2. Performance Grade: ANSI/WDMA I.S. 1A Heavy Duty.
 - 3. Performance Grade by Location:

- a. ANSI/WDMA I.S. 1A Extra Heavy Duty: public toilets janitor's closets assembly spaces exits.
4. Architectural Woodwork Standards Quality Grade: Custom.
5. Faces: Single-ply wood veneer not less than **1/50 inch** thick.
 - a. Species: See Door and Finish Schedule.
6. Exposed Vertical and Top Edges: Same species as faces - Architectural Woodwork Standards edge Type A.
 - a. Mineral-Core Doors: At hinge stiles, provide laminated-edge construction with improved screw-holding capability and split resistance. Comply with specified requirements for exposed edges.
 - 1) Screw-Holding Capability: **550 lbf** in accordance with WDMA T.M. 10.
7. Core for Non-Fire-Rated Doors:
 - a. ANSI A208.1, Grade LD-1 particleboard.

2.4 FABRICATION

- A. Factory fit doors to suit frame-opening sizes indicated.
 1. Comply with clearance requirements of referenced quality standard for fitting unless otherwise indicated.
 2. Comply with NFPA 80 requirements for fire-rated doors.
- B. Factory machine doors for hardware that is not surface applied.
 1. Locate hardware to comply with DHI-WDHS-3.
 2. Comply with final hardware schedules, door frame Shop Drawings, ANSI/BHMA-156.115-W, and hardware templates.
 3. Coordinate with hardware mortises in metal frames, to verify dimensions and alignment before factory machining.
 4. For doors scheduled to receive electrified locksets, provide factory-installed raceway and wiring to accommodate specified hardware.
 5. Metal Astragals: Factory machine astragals and formed-steel edges for hardware for pairs of fire-rated doors.
- C. Transom and Side Panels:
 1. Fabricate matching panels with same construction, exposed surfaces, and finish as specified for associated doors.
 2. Finish bottom edges of transoms and top edges of rabbeted doors same as door stiles.
 3. Fabricate door and transom panels with full-width, solid-lumber meeting rails.
 4. Provide factory-installed spring bolts for concealed attachment into jambs of metal door frames.

- D. Openings: Factory cut and trim openings through doors.
 - 1. Light Openings: Trim openings with moldings of material and profile indicated.
 - 2. Glazing: Factory install glazing in doors indicated to be factory finished. Comply with applicable requirements in Section 088000 "Glazing."
 - 3. Louvers: Factory install louvers in prepared openings.

PART 3 - EXECUTION

3.1 INSTALLATION

- A. Hardware: For installation, see Section 087100 "Door Hardware."
- B. Install doors and frames to comply with manufacturer's written instructions and referenced quality standard, and as indicated.
- C. Install frames level, plumb, true, and straight.
 - 1. Shim as required with concealed shims. Install level and plumb to a tolerance of **1/8 inch in 96 inches**.
- D. Factory-Fitted Doors: Align in frames for uniform clearance at each edge.

3.2 ADJUSTING

- A. Operation: Rehang or replace doors that do not swing or operate freely.
- B. Finished Doors: Replace doors that are damaged or that do not comply with requirements. Doors may be repaired or refinished if Work complies with requirements and shows no evidence of repair or refinishing.

END OF SECTION 081416

SECTION 083326 - OVERHEAD COILING GRILLES

PART 1 - GENERAL

1.1 SUMMARY

A. Section Includes:

1. Open-curtain overhead coiling grilles.
2. Closed-curtain overhead coiling grilles.

B. Related Requirements:

1. Section 055000 "Metal Fabrications" for miscellaneous steel supports, angle-framing of grille opening, corner guards, and bollards.

1.2 ACTION SUBMITTALS

A. Product Data: For each type and size of overhead coiling grille and accessory.

1. Include construction details, material descriptions, dimensions of individual components, profiles for curtain components, and finishes.
2. Include rated capacities, operating characteristics, electrical characteristics, and furnished accessories.

B. Shop Drawings: For each installation and for special components not dimensioned or detailed in manufacturer's product data.

1. Include plans, elevations, sections, and mounting details.
2. Include details of equipment assemblies. Indicate dimensions, required clearances, method of field assembly, components, and location and size of each field connection.
3. Include points of attachment and their corresponding static and dynamic loads imposed on structure.
4. For exterior components, include details of provisions for assembly expansion and contraction.
5. Show locations of controls, locking devices, and other accessories.
6. Include diagrams for power, signal, and control wiring.

C. Samples for Initial Selection: Manufacturer's finish charts showing full range of colors and textures available for units with factory-applied finishes.

1. Include similar Samples of accessories involving color selection.

1.3 INFORMATIONAL SUBMITTALS

- A. Qualification Data: For Installer.
- B. Sample Warranty: For special warranty.

1.4 CLOSEOUT SUBMITTALS

- A. Maintenance Data: For overhead coiling grilles to include in maintenance manuals.

1.5 QUALITY ASSURANCE

- A. Installer Qualifications: An entity that employs installers and supervisors who are trained and approved by manufacturer for both installation and maintenance of units required for this Project.
- B. Accessibility Standard: Comply with applicable provisions in ICC A117.1.

1.6 WARRANTY

- A. Special Warranty: Manufacturer agrees to repair or replace components of grilles that fail in materials or workmanship within specified warranty period.
 - 1. Warranty Period: Two years from date of Substantial Completion.

PART 2 - PRODUCTS

2.1 PERFORMANCE REQUIREMENTS

2.2 OPEN-CURTAIN GRILLE ASSEMBLY

- A. Open-Curtain Grille: Overhead coiling grille with a curtain having a network of horizontal rods that interconnect with vertical links.
 - 1. Basis-of-Design Product: Subject to compliance with requirements, provide Cornell; CrossingGard ERG-IBC or Approved Equivalent by one of the following:
 - a. ACME Rolling Doors
 - b. Advanced Door Technologies
 - c. Alpine Overhead Doors, Inc
 - d. Alumatec Pacific Products
 - e. Amarr Company
 - f. C.H.I. Overhead Doors, Inc.
 - g. City Gates USA
 - h. Clopay Building Products
 - i. Dynaflair Corporation
 - j. Dynamic Closures Corporation

- k. Lawrence Roll-Up Doors, Inc.
 - l. McKeon Door Company
 - m. Metro Door LLC
 - n. Overhead Door Corporation
- B. Operation Cycles: Grille components and operators capable of operating for not less than 10,000. One operation cycle is complete when a grille is opened from the closed position to the fully open position and returned to the closed position.
- C. Grille Curtain Material: Aluminum.
- 1. Rod Spacing: Approximately 2 inches o.c.
 - 2. Link Spacing: Approximately 9 inches apart in a straight in-line pattern.
 - 3. Spacers: Metal tubes matching curtain material.
- D. Curtain Jamb Guides: Aluminum with exposed finish matching curtain slats. Provide continuous integral wear strips to prevent metal-to-metal contact and to minimize operational noise.
- E. Locking Devices: Equip grille with AutoLock manual lifting jamb lock assemblies, concealed at each jamb. Lock mechanism shall not interfere with normal electric operation, fail-safe or emergency response self opening features. .
- F. Manual Grille Operator: Push-up operation.
- 1. Provide operator with manufacturer's standard removable operating arm.
- G. Electric Grille Operator:
- 1. Usage Classification: Light duty, up to 10 cycles per hour.
 - 2. Operator Location: As indicated on Drawings.
 - 3. Safety: Listed according to UL 325 by a qualified testing agency for commercial or industrial use; moving parts of operator enclosed or guarded if exposed and mounted at 8 feet or lower.
 - 4. Motor Exposure: Interior.
 - 5. Motor Electrical Characteristics:
 - a. See Electrical Drawings for Horsepower and Voltage Requirements
 - 6. Emergency Manual Operation: Chain type.
 - 7. Control Station: Where indicated on Drawings.
 - 8. Other Equipment: Audible and visual signals Emergency-egress release Self-opening mechanism.
- H. Curtain Accessories: Equip grille with astragal push/pull handles and pole hook.
- I. Grille Finish:
- 1. Aluminum Finish: Mill.
 - 2. Baked-Enamel or Powder-Coat Finish: Color as indicated by manufacturer's designations.

3. Factory Prime Finish: Manufacturer's standard color.
4. PVC Spacers: Color as indicated by manufacturer's designations.

2.3 MATERIALS, GENERAL

- A. Electrical Components, Devices, and Accessories: Listed and labeled as defined in NFPA 70, by a qualified testing agency, and marked for intended location and application.

2.4 HOODS AND ACCESSORIES

- A. General: Form sheet metal hood to entirely enclose coiled curtain and operating mechanism at opening head. Contour to fit end brackets to which hood is attached. Roll and reinforce top and bottom edges for stiffness. Form closed ends for surface-mounted hoods and fascia for any portion of between-jamb mounting that projects beyond wall face. Equip hood with intermediate support brackets as required to prevent sagging.
 1. Galvanized Steel: Nominal **0.028-inch**- thick, hot-dip galvanized-steel sheet with **G90** zinc coating, complying with ASTM A653/A653M.
 2. Stainless Steel: **0.025-inch**- thick, stainless steel sheet, Type 304, complying with ASTM A666 or ASTM A240/A240M.
 3. Aluminum: **0.040-inch**- thick aluminum sheet, complying with **ASTM B209**, of alloy and temper recommended by manufacturer and finisher for type of use and finish indicated.
- B. Removable Metal Soffit: Formed or extruded from same metal and with same finish as curtain if hood is mounted above ceiling unless otherwise indicated.
- C. Mounting Frame: Manufacturer's standard mounting frame designed to support grille; factory fabricated from ASTM A36/A36M structural-steel tubes, hot-dip galvanized per ASTM A123/A123M; fastened to floor and structure above grille; to be built into wall construction; and complete with anchors, connections, and fasteners.
- D. Push/Pull Handles: Equip push-up-operated or emergency-operated grille with lifting handles on each side of grille, finished to match grille.
- E. Pull-Down Strap: Provide pull-down straps for grilles more than **84 inches** high.
- F. Pole Hooks: Provide pole hooks and poles for grilles more than **84 inches** high.

2.5 GENERAL FINISH REQUIREMENTS

- A. Comply with NAAMM/NOMMA 500 for recommendations for applying and designating finishes.
- B. Appearance of Finished Work: Noticeable variations in same piece are not acceptable. Variations in appearance of adjoining components are acceptable if they are within the

range of approved Samples and are assembled or installed to minimize contrast.

2.6 ALUMINUM FINISHES

- A. Mill Finish: Manufacturer's standard.
- B. Clear Anodic Finish: AAMA 611, AA-M12C22A31, Class II, 0.010 mm or thicker.

2.7 STEEL AND GALVANIZED-STEEL FINISHES

- A. Factory Prime Finish: Manufacturer's standard primer, compatible with field-applied finish. Comply with coating manufacturer's written instructions for cleaning, pretreatment, application, and minimum dry film thickness.
- B. Baked-Enamel or Powder-Coat Finish: Manufacturer's standard baked-on finish consisting of prime coat and thermosetting topcoat. Comply with coating manufacturer's written instructions for cleaning, pretreatment, application, and minimum dry film thickness.

2.8 STAINLESS STEEL FINISHES

- A. Surface Preparation: Remove tool and die marks and stretch lines, or blend into finish.
- B. Polished Finishes: Grind and polish surfaces to produce uniform finish, free of cross scratches.
 - 1. Run grain of directional finishes with long dimension of each piece.
 - 2. When polishing is completed, passivate and rinse surfaces. Remove embedded foreign matter and leave surfaces chemically clean.
 - 3. Directional Satin Finish: No. 4.
- C. Bright, Cold-Rolled, Unpolished Finish: No. 2B.

PART 3 - EXECUTION

3.1 INSTALLATION

- A. Install overhead coiling grilles and operating equipment complete with necessary hardware, anchors, inserts, hangers, and equipment supports, according to manufacturer's written instructions and as specified.
- B. Install overhead coiling grilles, hoods, controls, and operators at the mounting locations indicated for each grille.
- C. Accessibility: Install overhead coiling grilles, switches, and controls along accessible routes in compliance with the accessibility standard.

- D. Power-Operated Grilles: Install automatic garage grille openers according to UL 325.

3.2 MAINTENANCE SERVICE

- A. Initial Maintenance Service: Beginning at Substantial Completion, maintenance service is to include 12 months' full maintenance by skilled employees of coiling-grille Installer. Include quarterly preventive maintenance, repair or replacement of worn or defective components, lubrication, cleaning, and adjusting as required for proper grille operation. Parts and supplies are to be manufacturer's authorized replacement parts and supplies. Confirm needs with owner.
 - 1. Perform maintenance, including emergency callback service, during normal working hours.

3.3 DEMONSTRATION

- A. Engage a factory-authorized service representative to train Owner's maintenance personnel to adjust, operate, and maintain overhead coiling grilles.

END OF SECTION 083326

SECTION 084126.23 - INTERIOR ALL-GLASS ENTRANCES

PART 1 - GENERAL

1.1 SUMMARY

A. Section Includes:

1. Interior, manual-sliding, all-glass entrance systems.

B. Related Requirements:

1. Section 055000 "Metal Fabrications" for overhead-steel support for interior all-glass entrance systems.

1.2 PREINSTALLATION MEETINGS

- A. Preinstallation Conference: Conduct conference at Project site.

1.3 ACTION SUBMITTALS

A. Product Data:

1. Interiorframless track sliding door system. .
2. Wood, manual-sliding door.

B. Product Data Submittals: For each product.

1. Construction details, material descriptions, dimensions of individual components and profiles, and finishes.

C. Shop Drawings:

1. Plans, elevations, and sections.
2. Details of fittings, sliding door carrier assemblies and tracks, and glazing, including isometric drawings of fittings.
3. Door hardware locations, mounting heights, and installation requirements.
4. Wood door and fittings.

- D. Samples for Initial Selection: Manufacturer's standard color sheets, showing full range of available colors for each type of fitting, accessory fitting, glass, and door hardware.

- E. Entrance Door Hardware Schedule: Prepared by or under supervision of supplier, detailing fabrication and assembly of door hardware, as well as procedures and diagrams. Coordinate final door hardware schedule with door components, assemblies, and related work to ensure proper size, thickness, hand, function, and finish of door

hardware.

1.4 INFORMATIONAL SUBMITTALS

- A. Sample Warranties: For interior all-glass entrance systems.

1.5 CLOSEOUT SUBMITTALS

- A. Operation and Maintenance Data: For interior all-glass entrance systems. Furnish a complete set of specialized tools and maintenance instructions as required for Owner's continued adjustment, maintenance, and removal and replacement of door hardware.

1.6 QUALITY ASSURANCE

- A. Installer Qualifications:
 - 1. Fabricator of products.
- B. Product Options: Information on Drawings and in Specifications establishes requirements for aesthetic effects and performance characteristics of assemblies. Aesthetic effects are indicated by dimensions, arrangements, alignment, and profiles of components and assemblies as they relate to sightlines, to one another, and to adjoining construction.
 - 1. Do not change intended aesthetic effects, as judged solely by Architect, except with Architect's approval. If changes are proposed, submit comprehensive explanatory data to Architect for review.

1.7 WARRANTY

- A. Special Warranty: Manufacturer and Installer agree to repair or replace components of interior all-glass entrance systems that fail in materials or workmanship within specified warranty period.
 - 1. Failures include, but are not limited to, the following:
 - a. Faulty operation of sliding door track.
 - b. Deterioration of metals, metal finishes, and other materials beyond normal use.
 - 2. Warranty Period: Two years from date of Substantial Completion.

PART 2 - PRODUCTS

2.1 INTERIOR, MANUAL-SLIDING, ALL-GLASS ENTRANCE SYSTEMS

- A. Basis-of-Design Product: Subject to compliance with requirements, provide dormakaba MUTO Comfort L80; with Sidelite and wood door or Approved Equivalent by one of the following:
1. Avanti Systems USA
 2. GGI; General Glass International
 3. Virginia Glass Products Corporation
 4. Wilson Systems
 5. Tubelite
- B. Fitting Configuration:
1. Door Fittings: Continuous channel at top.
 2. Sidelight Fittings: Recessed glazing channel at top and continuous rail fitting at bottom See Frame Type F13 on A401.
- C. Fitting Material: Aluminum.
- D. Rail Fittings:
1. Height:
 - a. Top Rail: As indicated.
 - b. Bottom Rail: As indicated.
 2. Profile: Square.
 3. End Caps: Manufacturer's standard precision-fit end caps for rail fittings.
- E. Anchors and Fastenings: Concealed.
- F. Door Hardware: In sizes, quantities, and types recommended by manufacturer for interior all-glass entrance systems indicated.
1. Opening-Force Requirements:
 - a. Egress Doors: Not more than **30 lbf** to set the door in motion and not more than **15 lbf** to close the door or open it to its minimum required width.
 - b. Accessible Interior Sliding Doors: Not more than **5 lbf** to fully open door.
 2. Door Pulls: As selected from manufacturer's full range.
 3. Deadbolt operated by key outside and thumbturn inside.
 4. Cylinders: As specified in Section 087100 "Door Hardware."
 5. Sliding Door Carrier Assemblies and Tracks:
 - a. General: Provide manufacturer's framing, headers, carrier assemblies, tracks, and accessories required for a complete installation.

- b. Top-Hung System: Overhead track assembly for supporting wood door and fixed glass panels hung from roller assembly.
 - 1) Overhead Track:
 - a) Mount: Wall.
 - b) Size: As indicated on Drawings.
 - c) Material: Aluminum.
 - 2) Rollers: Adjustable, heavy-duty ball bearing rollers (two per panel).
 - 3) Break Metal Cover: Aluminum.
 - 4) Floor Support:
 - a) Mount: Floor guide.
 - b) Size: As indicated on Drawings.
 - c) Material: Match overhead track.
 - 5) Accessory Components: Door stops, roller, and track/guide mounts.

2.2 MATERIALS

- A. Aluminum: **ASTM B221** with strength and durability characteristics of not less than Alloy 6063-T5 for extruded bars, rods, profiles, and tubes. **ASTM B209** for sheet and plate.
 - 1. Color Anodic Finish: AAMA 611, AA-M12C22A42/A44, Class I, 0.018 mm or thicker.
 - a. Color: Confirm with Architect..
- B. Stainless Steel Sheet, Strip, Plate, and Flat Bars: ASTM A240/A240M or ASTM A666, austenitic stainless steel, Type 304.
 - 1. Finish: ASTM A480/480M No. 6 dull satin finish.
- C. Stainless Steel Tubing: ASTM A240/A240M or ASTM A666, austenitic stainless steel, Type 304.
 - 1. Finish: 280-Grit Polished Finish: Fine finish.
 - a. Polished and Buffed Finish: Buff to match Architect's sample.
- D. Stainless Steel Bars and Shapes: ASTM A276, Type 304.
 - 1. Finish: ASTM A480/480M No. 6 dull satin finish.
- E. Structural Shapes, Plates, and Bars: ASTM A36/A36M.

2.3 FABRICATION

- A. Provide holes and cutouts in glass to receive hardware, fittings, and accessory fittings before tempering glass. Do not cut, drill, or make other alterations to glass after tempering.
 - 1. Fully temper glass using horizontal (roller-hearth) process, and fabricate so that when glass is installed, roll-wave distortion is parallel with bottom edge of door or lite.
- B. Factory assemble components and factory install hardware and fittings to greatest extent possible.

PART 3 - EXECUTION

3.1 INSTALLATION, GENERAL

- A. Install interior all-glass entrance systems and associated components in accordance with manufacturer's written instructions.
- B. Set units level, plumb, and true to line, with uniform joints.
- C. Maintain uniform clearances between adjacent components.
- D. Lubricate hardware and other moving parts in accordance with manufacturer's written instructions.
- E. Set, seal, and grout floor closer cases as required to suit hardware and substrate indicated.

3.2 FIELD QUALITY CONTROL

- A. Inspection Agency: Engage a qualified inspector to perform inspections.
- B. Inspections:
 - 1. Egress Door Inspections: Inspect each interior all-glass entrance door equipped with panic hardware, located in an exit enclosure, electrically controlled, and equipped with special locking arrangements, in accordance with NFPA 101, Ch. 7 "Means of Egress," Section "Means of Egress Components," Article "Inspection of Door Openings."
- C. Interior all-glass entrance systems will be considered defective if they do not pass inspections.
- D. Prepare inspection reports.

Intersect Studio, LLC
23046

Kalamazoo Crosstown
Parkway Facility
Kalamazoo, Michigan

END OF SECTION 084126.23

SECTION 084213 - ALUMINUM-FRAMED ENTRANCES

PART 1 - GENERAL

1.1 SUMMARY

A. Section Includes:

1. Aluminum-framed entrance door systems.

B. Related Requirements:

1. Section 081116.23 "Interior Aluminum Doors and Frames" for interior aluminum framing.
2. Section 084226 "All-Glass Entrances" for systems without aluminum support framing.

1.2 PREINSTALLATION MEETINGS

- A. Preinstallation Conference: Conduct conference at Project site.

1.3 ACTION SUBMITTALS

A. Product Data:

1. Aluminum-framed entrance door systems.

B. Product Data Submittals: For each product.

1. Construction details, material descriptions, dimensions of individual components and profiles, and finishes.
2. Operating characteristics, electrical characteristics, and furnished accessories.

C. Shop Drawings:

1. Plans, elevations, sections, full-size details, and attachments to other work.
2. Details of provisions for assembly expansion and contraction and for draining moisture occurring within the assembly to the exterior.
3. Full-size isometric details of each type of vertical-to-horizontal intersection of aluminum-framed entrance door systems, showing the following:
 - a. Joinery, including concealed welds.
 - b. Anchorage.
 - c. Expansion provisions.
 - d. Glazing.
 - e. Flashing and drainage.

4. Connection to and continuity with adjacent thermal, weather, air, and vapor barriers.
 5. Point-to-point wiring diagrams showing the following:
 - a. Power requirements for each electrically operated door hardware.
 - b. Location and types of switches, signal device, conduit sizes, and number and size of wires.
 6. Signed and sealed by the qualified professional engineer responsible for their preparation.
- D. Samples for Verification: Actual sample of finished products for each type of exposed finish.
1. Size: Manufacturers' standard size.
- E. Entrance Door Hardware Schedule: Prepared by or under supervision of supplier, detailing fabrication and assembly of entrance door hardware, as well as procedures and diagrams. Coordinate final entrance door hardware schedule with doors, frames, and related work to ensure proper size, thickness, hand, function, and finish of entrance door hardware.
- F. Sustainable Design Submittals:
1. Third-Party Certifications: For each product.
 2. Third-Party-Certified Life-Cycle Assessment: For each product.
- 1.4 INFORMATIONAL SUBMITTALS
- A. Energy Performance Certificates: For aluminum-framed entrance door systems, accessories, and components, from manufacturer.
1. Basis for Certification: NFRC-certified energy performance values for each aluminum-framed entrance.
- B. Product Test Reports: For aluminum-framed entrance door systems, for tests performed by a qualified testing agency manufacturer and witnessed by a qualified testing agency.
- C. Field Quality-Control Reports: For aluminum-framed entrance door systems.
- D. Delegated Design Engineer Qualifications: For aluminum-framed entrance and storefront systems.
- E. Sample Warranties: For aluminum-framed entrance door systems.
- 1.5 CLOSEOUT SUBMITTALS
- A. Operation and Maintenance Data: For aluminum-framed entrance door systems.

1.6 QUALITY ASSURANCE

- A. Installer Qualifications:
 - 1. Fabricator of products.
- B. Delegated Design Engineer Qualifications: A professional engineer who is legally qualified to practice in state where Project is located and who is experienced in providing engineering services of the type indicated.
- C. Product Options: Information on Drawings and in Specifications establishes requirements for aesthetic effects and performance characteristics of assemblies. Aesthetic effects are indicated by dimensions, arrangements, alignment, and profiles of components and assemblies as they relate to sightlines, to one another, and to adjoining construction.
 - 1. Do not change intended aesthetic effects, as judged solely by Architect, except with Architect's approval. If changes are proposed, submit comprehensive explanatory data to Architect for review.

1.7 WARRANTY

- A. Special Warranty: Manufacturer and Installer agree to repair or replace components of aluminum-framed entrance door systems that fail in materials or workmanship within specified warranty period.
 - 1. Failures include, but are not limited to, the following:
 - a. Faulty operation of doors.
 - b. Deterioration of metals, metal finishes, and other materials beyond normal weathering use.
 - 2. Warranty Period: Two years from date of Substantial Completion.
- B. Special Finish Warranty, Factory-Applied Finishes: Standard form in which manufacturer agrees to repair finishes or replace aluminum that shows evidence of deterioration of factory-applied finishes within specified warranty period.
 - 1. Deterioration includes, but is not limited to, the following:
 - a. Color fading more than 5 Delta E units when tested in accordance with ASTM D2244.
 - b. Chalking in excess of a No. 8 rating when tested in accordance with ASTM D4214.
 - c. Cracking, checking, peeling, or failure of paint to adhere to bare metal.
 - 2. Warranty Period: Five years from date of Substantial Completion.
- C. Special Finish Warranty, Anodized Finishes: Standard form in which manufacturer agrees to repair finishes or replace aluminum that shows evidence of deterioration of

anodized finishes within specified warranty period.

1. Deterioration includes, but is not limited to, the following:
 - a. Color fading more than 5 Delta E units when tested in accordance with ASTM D 2244.
 - b. Chalking in excess of a No. 8 rating when tested in accordance with ASTM D 4214.
 - c. Cracking, peeling, or chipping.
2. Warranty Period: Five years from date of Substantial Completion.

PART 2 - PRODUCTS

2.1 SOURCE LIMITATIONS

- A. Obtain all components of aluminum-framed entrance door systems, including framing and accessories, from single manufacturer.

2.2 PERFORMANCE REQUIREMENTS

- A. General Performance: Comply with performance requirements specified, as determined by testing of aluminum-framed entrance door systems representing those indicated for this Project without failure due to defective manufacture, fabrication, installation, or other defects in construction.
- B. Structural Loads:
 1. Wind Loads: As indicated on Drawings.
 2. Other Design Loads: As indicated on Drawings.
- C. Structural: Test in accordance with ASTM E330/E330M as follows:
 1. When tested at 150 percent of positive and negative wind-load design pressures, entrance doors, including anchorage, do not evidence material failures, structural distress, or permanent deformation of main framing members exceeding 0.2 percent of span.
 2. Test Durations: As required by design wind velocity, but not less than 10 seconds.
- D. Water Penetration under Static Pressure: Test in accordance with ASTM E331 as follows:
 1. No uncontrolled water entry at a 12 psf static air pressure differential with water applied at a minimum rate of 5 gal/sf when tested per ASTM E 331.
- E. Energy Performance: Certified and labeled by manufacturer for energy performance as follows:

1. Thermal Transmittance (U-factor):
 - a. Coordinate performance with 08 8000 Glazing.
 2. Solar Heat-Gain Coefficient (SHGC):
 - a. Coordinate performance with 08 8000 Glazing.
 3. Air Leakage:
 - a. Fixed Glazing and Framing Areas: Air leakage for the system of not more than **0.06 cfm/sq. ft.** at a static-air-pressure differential of **6.24 lbf/sq. ft.** when tested in accordance with ASTM E283.
 - b. Entrance Doors: Air leakage of not more than **1.0 cfm/sq. ft.** at a static-air-pressure differential of **1.57 lbf/sq. ft.**
- F. Noise Reduction: Test in accordance with ASTM E90, with ratings determined by ASTM E1332, as follows.
1. Outdoor-Indoor Transmission Class: Minimum 27.
 2. STC: 28
- G. Thermal Movements: Allow for thermal movements resulting from ambient and surface temperature changes.
1. Temperature Change: **120 deg F**, ambient; **180 deg F**, material surfaces.

2.3 ALUMINUM-FRAMED ENTRANCE DOOR SYSTEMS

- A. Basis-of-Design Product: Subject to compliance with requirements, provide Tubelite Inc.; E4500 Series Storefront System or Approved Equivalent by one of the following:
1. Andersen Windows, Inc.; Andersen Corporation
 2. Arcadia Inc.
 3. CMI Architectural Products, Inc.
 4. Coral Architectural Products; Coral Industries, Inc.
 5. EFCO Corporation
 6. Kawneer Company, Inc.; Arconic Corporation
 7. Leed Himmel Industries, Inc.
 8. Manko Window Systems, Inc.
 9. OldCastle BuildingEnvelope (OBE)
 10. Pittco Architectural Metals, Inc.
 11. Trulite Glass & Aluminum Solutions, LLC.
 12. U.S. Aluminum; C.R. Laurence Co., Inc.; CRH Americas, Inc.
 13. YKK AP America Inc.
- B. Entrance Doors: Manufacturer's standard glazed entrance doors for manual-swing or automatic operation.
1. Door Construction: **2-inch** overall thickness, with minimum **0.188-inch**- thick,

- extruded-aluminum tubular rail and stile members. Mechanically fasten corners with reinforcing brackets that are deeply penetrated and fillet welded or that incorporate concealed tie rods.
2. Door Design: As indicated.
 3. Glazing Stops and Gaskets: Beveled, snap-on, extruded-aluminum stops and preformed gaskets.
 - a. Provide nonremovable glazing stops on outside of door.
 4. Door Finish: Per Drawings.
- C. Framing Members: Manufacturer's standard extruded aluminum, minimum **0.125 inch** thick and reinforced as required to support imposed loads.
1. Nominal Size: **1-3/4 by 4-1/2 inches**.
 2. Exterior Framing Construction: Thermally broken.
 3. Interior Vestibule Framing Construction: Nonthermal.
 4. Finish: Match door finish.
- D. Backer Plates: Manufacturer's standard, continuous backer plates for framing members, if not integral, where framing abuts adjacent construction.
- E. Brackets and Reinforcements: Manufacturer's standard high-strength aluminum with nonstaining, nonferrous shims for aligning system components.
- F. Materials:
1. Aluminum: Alloy and temper recommended by manufacturer for type of use and finish indicated.
 - a. Sheet and Plate: **ASTM B209**.
 - b. Extruded Bars, Rods, Profiles, and Tubes: **ASTM B221**.
 - c. Structural Profiles: ASTM B308/B308M.
 2. Steel Reinforcement:
 - a. Structural Shapes, Plates, and Bars: ASTM A36/A36M.
 - b. Cold-Rolled Sheet and Strip: ASTM A1008/A1008M.
 - c. Hot-Rolled Sheet and Strip: ASTM A1011/A1011M.
 3. Steel Reinforcement Primer: Manufacturer's standard zinc-rich, corrosion-resistant primer complying with SSPC-PS Guide No. 12.00; applied immediately after surface preparation and pretreatment. Select surface preparation methods in accordance with recommendations in SSPC-SP COM, and prepare surfaces in accordance with applicable SSPC standard.
- G. Recycled Content of Steel Products: Postconsumer recycled content plus one-half of preconsumer recycled content not less than 25 percent.

2.4 ACCESSORIES

- A. Automatic Door Operators: Section 087113 "Power Door Operators."
- B. Fasteners and Accessories: Manufacturer's standard corrosion-resistant, nonstaining, nonbleeding fasteners and accessories compatible with adjacent materials.
 - 1. Use self-locking devices where fasteners are subject to loosening or turning out from thermal and structural movements, wind loads, or vibration.
 - 2. Reinforce members as required to receive fastener threads.
 - 3. Use exposed fasteners with countersunk Phillips screw heads, finished to match framing system.
- C. Anchors: Three-way adjustable anchors with minimum adjustment of **1 inch** that accommodate fabrication and installation tolerances in material and finish compatible with adjoining materials and recommended by manufacturer.
 - 1. Concrete and Masonry Inserts: Hot-dip galvanized cast-iron, malleable-iron, or steel inserts complying with ASTM A123/A123M or ASTM A153/A153M requirements.
- D. Concealed Flashing: Manufacturer's standard corrosion-resistant, nonstaining, nonbleeding flashing compatible with adjacent materials.
- E. Bituminous Paint: Cold-applied asphalt-mastic paint containing no asbestos, formulated for **30-mil** thickness per coat.

2.5 FABRICATION

- A. Form or extrude aluminum shapes before finishing.
- B. Weld in concealed locations to greatest extent possible to minimize distortion or discoloration of finish. Remove weld spatter and welding oxides from exposed surfaces by descaling or grinding.
- C. Fabricate components that, when assembled, have the following characteristics:
 - 1. Profiles that are sharp, straight, and free of defects or deformations.
 - 2. Accurately fitted joints with ends coped or mitered.
 - 3. Physical and thermal isolation of glazing from framing members.
 - 4. Accommodations for thermal and mechanical movements of glazing and framing to maintain required glazing edge clearances.
 - 5. Fasteners, anchors, and connection devices that are concealed from view to greatest extent possible.
- D. Entrance Door Frames: Reinforce as required to support loads imposed by door operation and for installing entrance door hardware.
 - 1. At interior and exterior doors, provide compression weather stripping at fixed stops.

- E. Entrance Doors: Reinforce doors as required for installing entrance door hardware.
 - 1. At pairs of exterior doors, provide sliding-type weather stripping retained in adjustable strip and mortised into door edge.
 - 2. At exterior doors, provide weather sweeps applied to door bottoms.
- F. Entrance Door Hardware Installation: Factory install entrance door hardware to the greatest extent possible. Cut, drill, and tap for factory-installed entrance door hardware before applying finishes.
- G. After fabrication, clearly mark components to identify their locations in Project in accordance with Shop Drawings.

2.6 ALUMINUM FINISHES

- A. Clear Anodic Finish: AAMA 611, AA-M12C22A41, Class I, 0.018 mm or thicker.
- B. Color Anodic Finish: AAMA 611, AA-M12C22A42/A44, Class I, 0.018 mm or thicker.
 - 1. Color: Per Drawings.
- C. High-Performance Organic Finish, Two-Coat PVDF: Fluoropolymer finish complying with AAMA 2605 and containing not less than 70 percent PVDF resin by weight in color coat.
 - 1. Color and Gloss: Per Drawings.

PART 3 - EXECUTION

3.1 INSTALLATION OF ALUMINUM-FRAMED ENTRANCE DOOR SYSTEMS

- A. Comply with manufacturer's written instructions.
- B. Do not install damaged components.
- C. Fit joints to produce hairline joints free of burrs and distortion.
- D. Rigidly secure nonmovement joints.
- E. Install anchors with separators and isolators to prevent metal corrosion and electrolytic deterioration and to prevent impeding movement of moving joints.
- F. Seal perimeter and other joints watertight unless otherwise indicated.
- G. Metal Protection:
 - 1. Where aluminum is in contact with dissimilar metals, protect against galvanic action by painting contact surfaces with materials recommended by manufacturer

- for this purpose or installing nonconductive spacers.
- 2. Where aluminum is in contact with concrete or masonry, protect against corrosion by painting contact surfaces with bituminous paint.
- H. Set continuous sill members and flashing in full sealant bed, as specified in Section 079200 "Joint Sealants," to produce weathertight installation.
- I. Install joint filler behind sealant as recommended by sealant manufacturer.
- J. Install components plumb and true in alignment with established lines and grades.
- K. Install entrance doors to produce smooth operation and tight fit at contact points.
 - 1. Exterior Doors: Install to produce weathertight enclosure and tight fit at weather stripping.
 - 2. Field-Installed Entrance Door Hardware: Install surface-mounted entrance door hardware according to entrance door hardware manufacturers' written instructions using concealed fasteners to greatest extent possible.
- L. Install glazing as specified in Section 088000 "Glazing."

3.2 MAINTENANCE SERVICE

- A. Entrance Door Hardware Maintenance:
 - 1. Maintenance Tools and Instructions: Furnish a complete set of specialized tools and maintenance instructions as needed for Owner's continued adjustment, maintenance, and removal and replacement of entrance door hardware.

END OF SECTION 084213

SECTION 084313 - ALUMINUM-FRAMED STOREFRONTS

PART 1 - GENERAL

1.1 SUMMARY

A. Section Includes:

1. Aluminum-framed storefront systems.

B. Related Requirements:

1. Section 084126 "All-Glass Entrances and Storefronts" for systems without aluminum support framing.

1.2 PREINSTALLATION MEETINGS

- A. Preinstallation Conference: Conduct conference at Project site.

1.3 ACTION SUBMITTALS

A. Product Data:

1. For each type of product.
 - a. Include construction details, material descriptions, dimensions of individual components and profiles, and finishes.

B. Shop Drawings: For aluminum-framed storefronts. Include plans, elevations, sections, full-size details, and attachments to other work.

1. Include details of provisions for assembly expansion and contraction and for draining moisture occurring within the assembly to the exterior.
2. Include full-size isometric details of each type of vertical-to-horizontal intersection of aluminum-framed storefronts, showing the following:
 - a. Joinery, including concealed welds.
 - b. Anchorage.
 - c. Expansion provisions.
 - d. Glazing.
 - e. Flashing and drainage.

3. Show connection to and continuity with adjacent thermal, weather, air, and vapor barriers.

C. Samples for Initial Selection: For units with factory-applied color finishes.

1.4 INFORMATIONAL SUBMITTALS

- A. Qualification Data:
 - 1. For Installer.
 - 2. For professional engineer's experience with providing delegated design engineering services of the type indicated, including documentation that engineer is licensed in the state in which Project is located.
- B. Energy Performance Certificates: For aluminum-framed storefronts, accessories, and components, from manufacturer.
 - 1. Basis for Certification: NFRC-certified energy performance values for each aluminum-framed storefront.
- C. Source quality-control reports.
- D. Sample Warranties: For special warranties.

1.5 CLOSEOUT SUBMITTALS

- A. Maintenance Data: For aluminum-framed storefronts to include in maintenance manuals.
- B. Maintenance Data for Structural Sealant: For structural-sealant-glazed storefront to include in maintenance manuals. Include ASTM C1401 recommendations for post-installation-phase quality-control program.

1.6 QUALITY ASSURANCE

- A. Installer Qualifications: An entity that employs installers and supervisors who are trained and approved by manufacturer and that employs a qualified glazing contractor for this Project who is certified under the North American Contractor Certification Program (NACC) for Architectural Glass & Metal (AGM) contractors.
- B. Testing Agency Qualifications: Qualified in accordance with ASTM E699 for testing indicated and acceptable to Owner and Architect.
- C. Product Options: Information on Drawings and in Specifications establishes requirements for aesthetic effects and performance characteristics of assemblies. Aesthetic effects are indicated by dimensions, arrangements, alignment, and profiles of components and assemblies as they relate to sightlines, to one another, and to adjoining construction.
 - 1. Do not change intended aesthetic effects, as judged solely by Architect, except with Architect's approval. If changes are proposed, submit comprehensive explanatory data to Architect for review.

1.7 WARRANTY

- A. Special Warranty: Manufacturer agrees to repair or replace components of aluminum-framed storefronts that do not comply with requirements or that fail in materials or workmanship within specified warranty period.
1. Failures include, but are not limited to, the following:
 - a. Structural failures, including, but not limited to, excessive deflection.
 - b. Noise or vibration created by wind and thermal and structural movements.
 - c. Water penetration through fixed glazing and framing areas.
 - d. Failure of operating components.
 2. Warranty Period: Five years from date of Substantial Completion.
- B. Special Finish Warranty, Factory-Applied Finishes: Standard form in which manufacturer agrees to repair finishes or replace aluminum that shows evidence of deterioration of factory-applied finishes within specified warranty period.
1. Deterioration includes, but is not limited to, the following:
 - a. Color fading more than 5 Delta E units when tested in accordance with ASTM D2244.
 - b. Chalking in excess of a No. 8 rating when tested in accordance with ASTM D4214.
 - c. Cracking, checking, peeling, or failure of paint to adhere to bare metal.
 2. Warranty Period: Five years from date of Substantial Completion.
- C. Special Finish Warranty, Anodized Finishes: Standard form in which manufacturer agrees to repair finishes or replace aluminum that shows evidence of deterioration of anodized finishes within specified warranty period.
1. Deterioration includes, but is not limited to, the following:
 - a. Color fading more than 5 Delta E units when tested in accordance with ASTM D 2244.
 - b. Chalking in excess of a No. 8 rating when tested in accordance with ASTM D 4214.
 - c. Cracking, peeling, or chipping.
 2. Warranty Period: 10 years from date of Substantial Completion.

PART 2 - PRODUCTS

2.1 PERFORMANCE REQUIREMENTS

- A. Delegated Design: Engage a qualified professional engineer, as defined in Section 014000 "Quality Requirements," to design aluminum-framed storefronts.

- B. General Performance: Comply with performance requirements specified, as determined by testing of aluminum-framed storefronts representing those indicated for this Project without failure due to defective manufacture, fabrication, installation, or other defects in construction.
1. Aluminum-framed storefronts shall withstand movements of supporting structure, including, but not limited to, twist, column shortening, long-term creep, and deflection from uniformly distributed and concentrated live loads.
 2. Failure also includes the following:
 - a. Thermal stresses transferring to building structure.
 - b. Glass breakage.
 - c. Noise or vibration created by wind and thermal and structural movements.
 - d. Loosening or weakening of fasteners, attachments, and other components.
 - e. Failure of operating units.
- C. Structural Loads:
1. Wind Loads: As indicated on Drawings.
 2. Other Design Loads: As indicated on Drawings.
- D. Deflection of Framing Members Supporting Glass: At design wind load, as follows:
1. Deflection Normal to Wall Plane: Limited to 1/175 of length of span of the framing member for lengths of up to **13 feet 6 inches** and to 1/240 of length of span of the framing member plus **1/4 inch** for lengths greater than **13 feet 6 inches**.
 2. Deflection Parallel to Glazing Plane: Limited to amount not exceeding that which reduces glazing bite to less than 75 percent of design dimension and that which reduces edge clearance between framing members and glazing or other fixed components to less than **1/8 inch**.
 - a. Operable Units: Provide a minimum **1/16-inch** clearance between framing members and operable units.
- E. Structural: Test in accordance with ASTM E330/E330M as follows:
1. When tested at positive and negative wind-load design pressures, storefront assemblies do not evidence deflection exceeding specified limits.
 2. When tested at 150 percent of positive and negative wind-load design pressures, storefront assemblies, including anchorage, do not evidence material failures, structural distress, or permanent deformation of main framing members exceeding 0.2 percent of span.
 3. Test Durations: As required by design wind velocity, but not less than 10 seconds.
- F. Water Penetration under Static Pressure: Test in accordance with ASTM E331 as follows:
1. No evidence of water penetration through fixed glazing and framing areas when tested in accordance with a minimum static-air-pressure differential of 20 percent of positive wind-load design pressure, but not less than 12 lbf/sq. ft..

- G. Water Penetration under Dynamic Pressure: Test in accordance with AAMA 501.1 as follows:
1. No evidence of water penetration through fixed glazing and framing areas when tested at dynamic pressure equal to 20 percent of positive wind-load design pressure, but not less than 12 lbf/sq. ft..
 2. Maximum Water Leakage: In accordance with AAMA 501.1. Water leakage does not include water controlled by flashing and gutters, or water that is drained to exterior.
- H. Energy Performance: Certified and labelled by manufacturer for energy performance as follows:
1. Thermal Transmittance (U-factor):
 - a. Fixed Glazing and Framing Areas: U-factor for the system of not more than 0.51 Btu/sq. ft x h x deg F as determined in accordance with NFRC 100.
 - 1) Coordinate performance with 08 8000 Glazing.
 2. Solar Heat Gain Coefficient (SHGC):
 - a. Coordinate performance with Glazing 08 8000.
 3. Air Leakage:
 - a. Fixed Glazing and Framing Areas: Air leakage for the system of not more than **0.06 cfm/sq. ft.** at a static-air-pressure differential of **6.24 lbf/sq. ft.** when tested in accordance with ASTM E283.
 4. Condensation Resistance Factor (CRF):
- I. Noise Reduction: Test in accordance with ASTM E90, with ratings determined by ASTM E1332, as follows.
1. Outdoor-Indoor Transmission Class: Minimum 27.
- J. Thermal Movements: Allow for thermal movements resulting from ambient and surface temperature changes.
1. Temperature Change: **120 deg F**, ambient; **180 deg F**, material surfaces.

2.2 ALUMINUM-FRAMED STOREFRONT SYSTEMS

- A. Basis-of-Design Product: Subject to compliance with requirements, provide Tubelite Inc. T14000 Series Center Glaze Storefront or Approved Equivalent by one of the following:
1. Arcadia Inc.
 2. Boyd Aluminum Mfg. Co.

3. CMI Architectural Products, Inc.
4. Coral Architectural Products; Coral Industries, Inc.
5. EFCO Corporation
6. Kawneer Company, Inc.; Arconic Corporation
7. Leed Himmel Industries, Inc.
8. Manko Window Systems, Inc.
9. Pittco Architectural Metals, Inc.
10. Trulite Glass & Aluminum Solutions, LLC.
11. Tubelite Inc.
12. U.S. Aluminum; C.R. Laurence Co., Inc.; CRH Americas, Inc.
13. YKK AP America Inc.

- B. Source Limitations: Obtain all components of aluminum-framed storefront system, including framing and accessories, from single manufacturer.
- C. Framing Members: Manufacturer's extruded- or formed-aluminum framing members of thickness required and reinforced as required to support imposed loads.
1. Exterior Framing Construction: Thermally broken.
 2. Interior Vestibule Framing Construction: Thermally broken.
 3. Glazing System: Retained mechanically with gaskets on four sides.
 4. Glazing Plane: Front.
 5. Finish: Color anodic finish.
 6. Fabrication Method: Field-fabricated stick system.
 7. Aluminum: Alloy and temper recommended by manufacturer for type of use and finish indicated.
 8. Steel Reinforcement: As required by manufacturer.
- D. Backer Plates: Manufacturer's standard, continuous backer plates for framing members, if not integral, where framing abuts adjacent construction.
- E. Brackets and Reinforcements: Manufacturer's standard high-strength aluminum with nonstaining, nonferrous shims for aligning system components.

2.3 ALUMINUM-FRAMED STOREFRONT SYSTEMS - INTERIOR

- A. Basis-of-Design Product: Subject to compliance with requirements, provide Tubelite; E4500 or Approved Equivalent by one of the following:
1. Arcadia Inc.
 2. Boyd Aluminum Mfg. Co.
 3. CMI Architectural Products, Inc.
 4. Coral Architectural Products; Coral Industries, Inc.
 5. EFCO Corporation
 6. Kawneer Company, Inc.; Arconic Corporation
 7. Leed Himmel Industries, Inc.
 8. Manko Window Systems, Inc.
 9. Pittco Architectural Metals, Inc.
 10. Trulite Glass & Aluminum Solutions, LLC.
 11. Tubelite Inc.

12. U.S. Aluminum; C.R. Laurence Co., Inc.; CRH Americas, Inc.
13. YKK AP America Inc.

- B. Source Limitations: Obtain all components of aluminum-framed storefront system, including framing spandrel panels and accessories, from single manufacturer.
- C. Framing Members: Manufacturer's extruded- or formed-aluminum framing members of thickness required and reinforced as required to support imposed loads.
1. Interior Vestibule Framing Construction: Nonthermal.
 2. Glazing System: Retained mechanically with gaskets on four sides.
 3. Glazing Plane: Front.
 4. Finish: Clear anodic finish.
 5. Fabrication Method: Field-fabricated stick system.
 6. Aluminum: Alloy and temper recommended by manufacturer for type of use and finish indicated.
 7. Steel Reinforcement: As required by manufacturer.
- D. Backer Plates: Manufacturer's standard, continuous backer plates for framing members, if not integral, where framing abuts adjacent construction.
- E. Brackets and Reinforcements: Manufacturer's standard high-strength aluminum with nonstaining, nonferrous shims for aligning system components.

2.4 MATERIALS

- A. Sheet and Plate: **ASTM B209**.
- B. Extruded Bars, Rods, Profiles, and Tubes: **ASTM B221**.
- C. Structural Profiles: ASTM B308/B308M.
- D. Steel Reinforcement:
1. Structural Shapes, Plates, and Bars: ASTM A36/A36M.
 2. Cold-Rolled Sheet and Strip: ASTM A1008/A1008M.
 3. Hot-Rolled Sheet and Strip: ASTM A1011/A1011M.
- E. Steel Reinforcement Primer: Manufacturer's standard zinc-rich, corrosion-resistant primer complying with SSPC-PS Guide No. 12.00; applied immediately after surface preparation and pretreatment. Select surface preparation methods in accordance with recommendations in SSPC-SP COM, and prepare surfaces in accordance with applicable SSPC standard.

2.5 ACCESSORIES

- A. Fasteners and Accessories: Manufacturer's standard corrosion-resistant, nonstaining, nonbleeding fasteners and accessories compatible with adjacent materials.

1. Use self-locking devices where fasteners are subject to loosening or turning out from thermal and structural movements, wind loads, or vibration.
 2. Reinforce members as required to receive fastener threads.
 3. Use exposed fasteners with countersunk Phillips screw heads, finished to match framing system.
- B. Anchors: Three-way adjustable anchors with minimum adjustment of **1 inch** that accommodate fabrication and installation tolerances in material and finish compatible with adjoining materials and recommended by manufacturer.
- C. Concealed Flashing: Manufacturer's standard corrosion-resistant, nonstaining, nonbleeding flashing compatible with adjacent materials.
- D. Bituminous Paint: Cold-applied asphalt-mastic paint containing no asbestos, formulated for **30-mil** thickness per coat.
- E. Rigid PVC Filler.

2.6 FABRICATION

- A. Form or extrude aluminum shapes before finishing.
- B. Weld in concealed locations to greatest extent possible to minimize distortion or discoloration of finish. Remove weld spatter and welding oxides from exposed surfaces by descaling or grinding.
- C. Fabricate components that, when assembled, have the following characteristics:
1. Profiles that are sharp, straight, and free of defects or deformations.
 2. Accurately fitted joints with ends coped or mitered.
 3. Physical and thermal isolation of glazing from framing members.
 4. Accommodations for thermal and mechanical movements of glazing and framing to maintain required glazing edge clearances.
 5. Provisions for field replacement of glazing from exterior.
 6. Fasteners, anchors, and connection devices that are concealed from view to greatest extent possible.
- D. Mechanically Glazed Framing Members: Fabricate for flush glazing without projecting stops.
- E. After fabrication, clearly mark components to identify their locations in Project in accordance with Shop Drawings.

2.7 ALUMINUM FINISHES

- A. Clear Anodic Finish: AAMA 611, AA-M12C22A41, Class I, 0.018 mm or thicker.
- B. Color Anodic Finish: AAMA 611, AA-M12C22A42/A44, Class I, 0.018 mm or thicker.

1. Color: Dark bronze Champagne.

2.8 SOURCE QUALITY CONTROL

PART 3 - EXECUTION

3.1 INSTALLATION, GENERAL

- A. Comply with manufacturer's written instructions.
- B. Do not install damaged components.
- C. Fit joints to produce hairline joints free of burrs and distortion.
- D. Rigidly secure nonmovement joints.
- E. Install anchors with separators and isolators to prevent metal corrosion and electrolytic deterioration and to prevent impeding movement of moving joints.
- F. Seal perimeter and other joints watertight unless otherwise indicated.
- G. Metal Protection:
 1. Where aluminum is in contact with dissimilar metals, protect against galvanic action by painting contact surfaces with materials recommended by manufacturer for this purpose or by installing nonconductive spacers.
 2. Where aluminum is in contact with concrete or masonry, protect against corrosion by painting contact surfaces with bituminous paint.
- H. Set continuous sill members and flashing in full sealant bed, as specified in Section 079200 "Joint Sealants," to produce weathertight installation.
- I. Install joint filler behind sealant as recommended by sealant manufacturer.
- J. Install components plumb and true in alignment with established lines and grades.

3.2 INSTALLATION OF GLAZING

- A. Install glazing as specified in Section 088000 "Glazing."

3.3 ERECTION TOLERANCES

- A. Install aluminum-framed storefronts to comply with the following maximum tolerances:
 1. Plumb: **1/8 inch in 10 feet; 1/4 inch in 40 feet.**
 2. Level: **1/8 inch in 20 feet; 1/4 inch in 40 feet.**

3. Alignment:
 - a. Where surfaces abut in line or are separated by reveal or protruding element up to **1/2 inch** wide, limit offset from true alignment to **1/16 inch**.
 - b. Where surfaces are separated by reveal or protruding element from **1/2 to 1 inch** wide, limit offset from true alignment to **1/8 inch**.
 - c. Where surfaces are separated by reveal or protruding element of **1 inch** wide or more, limit offset from true alignment to **1/4 inch**.
4. Location: Limit variation from plane to **1/8 inch in 12 feet; 1/2 inch** over total length.

END OF SECTION 084313

SECTION 085653 - SECURITY WINDOWS

PART 1 - GENERAL

1.1 SUMMARY

A. Section Includes:

1. Fixed, transaction security windows.

1.2 ACTION SUBMITTALS

A. Product Data: For each type of product.

1. Include construction details, material descriptions, dimensions of individual components and profiles, weights and finishes for window units.

B. Shop Drawings: For security windows.

1. Include plans, elevations, sections, and attachment details.
2. Full-size section details of framing members, including internal armoring, reinforcement, and stiffeners.
3. Glazing details.
4. Details of transaction counter and speaking aperture.

C. Samples for Initial Selection: For frame members with factory-applied color finishes.

1.3 INFORMATIONAL SUBMITTALS

A. Qualification Data: For Installer and testing agency.

B. Product Test Reports: For each type of security window and accessory indicated as ballistics or forced-entry resistant, for tests performed by a qualified testing agency.

C. Configuration Disclosure Drawing: For each type of forced-entry-resistant security window, complying with ASTM F1233.

D. Sample Warranty: For special warranty.

1.4 FIELD CONDITIONS

A. Field Measurements: Verify actual dimensions of openings by field measurements before fabrication.

1.5 WARRANTY

- A. Special Warranty: Manufacturer agrees to repair or replace security windows that fail in materials or workmanship within specified warranty period.
 - 1. Warranty Period: 1 years from date of Substantial Completion.

PART 2 - PRODUCTS

2.1 PERFORMANCE REQUIREMENTS

- A. Attack Resistance: Provide units identical to those tested for compliance with requirements indicated, and as follows:
 - 1. Ballistics Resistance, UL 752: Level 3 in accordance with UL 752.
- B. Structural Loads: Security windows withstand the effects of wind loads, with no permanent deformation or breakage of components within window assembly when tested in accordance with ASTM E330/E330M.
- C. Air Leakage, Fixed Glazing and Framing: Provide windows with maximum air leakage through fixed glazing and framing areas of **0.06 cfm/sq. ft.** of fixed wall area when tested in accordance with ASTM E283 at a minimum static-air-pressure difference of **1.57 lbf/sq. ft.**

2.2 FIXED, TRANSACTION SECURITY WINDOWS

- A. Fixed, Transaction Security Windows: Provide fixed, transaction security windows with operable sash or ventilator capable of allowing transfer of currency and documents.
 - 1. Basis-of-Design Product: Subject to compliance with requirements, provide Armortex Transaction Window or Approved Equivalent by one of the following:
 - a. C.R. Laurence Co., Inc.; CRH Americas, Inc.
 - b. Chicago Bullet Proof Systems
 - c. Creative Industries, Inc
 - d. Krieger Specialty Products Company
 - e. National Bullet Proof, Inc
 - f. Norshield Security Products, LLC
 - g. Overly Door Company
 - h. Protective Structures, Ltd.
 - i. Quikserv, Inc.
 - j. Ready Access
 - k. Ross Technology Company
 - l. SABIC Innovative Plastics IP BV
- B. Configuration: One fixed-glazed panel.

- C. Framing: Fabricate perimeter framing, mullions, and glazing stops from aluminum as follows:
 - 1. Profile: Manufacturer's standard, with minimum face dimension indicated.
 - a. Minimum Face Dimension: 1-1/2 inches.
 - 2. Depth: 5 or 6 inches.
- D. Head and Jamb Framing: Designed for neoprene setting block and glazing tape, or as required by manufacturer.
- E. Channel-Frame Sill: Formed from stainless steel and designed for sealant glazing.
 - 1. Transaction Counter: Stainless steel, **12 inches** deep by width as indicated on Drawings, with integral drain tray as indicated on Drawings.
- F. Glazing and Glazing Materials: Comply with requirements in Section 088853 "Security Glazing."
- G. Glazing Meeting Edges: Polished glazing.
- H. Materials:
 - 1. Mild Steel Plates, Shapes, and Bars: ASTM A36/A36M.
 - 2. Cold-Rolled Steel Sheet: ASTM A1008/A1008M, CS (Commercial Steel), Type B; suitable for exposed applications.
 - 3. Metallic-Coated Steel Sheet: ASTM A653/A653M, CS (Commercial Steel), Type B; with **G60** zinc (galvanized) or **A60** zinc-iron-alloy (galvannealed) coating designation.
 - 4. Hot-Rolled Steel Sheet: ASTM A1011/A1011M, CS (Commercial Steel), Type B; free of scale, pitting, or surface defects; pickled and oiled.
 - 5. Stainless Steel Sheet, Strip, Plate, and Flat Bars: ASTM A666 or ASTM A240/A240M, austenitic stainless steel, Type 304.
 - 6. Aluminum Extrusions: **ASTM B221**. Provide alloy and temper recommended by manufacturer for strength, corrosion resistance, and application of required finish, but not less than **22,000-psi** ultimate tensile strength.
 - 7. Aluminum Sheet and Plate: **ASTM B209**.

2.3 FABRICATION

- A. General: Fabricate security windows to provide a complete system for assembly of components and anchorage of window units.
 - 1. Provide units that are reglazable from the secure side without dismantling the attack side of framing.
 - 2. Prepare security windows for field glazing unless preglazing at the factory is indicated.
- B. Provide weep holes and internal water passages for exterior security windows to

conduct infiltrating water to the exterior.

- C. Thermally Improved or Thermally Broken Construction: Fabricate framing with an integral, concealed, low-conductance thermal barrier, located between exterior materials and members exposed on interior in a manner that eliminates direct metal-to-metal contact.
- D. Framing: Miter or cope corners the full depth of framing; weld and dress smooth.
 - 1. Fabricate framing with manufacturer's standard, internal opaque armoring in thicknesses required for security windows to comply with ballistics-resistance performance indicated.
- E. Glazing Stops: Finish glazing stops to match security window framing.
 - 1. Attack-Side (Exterior) Glazing Stops: Welded or integral to framing.
 - 2. Secure-Side (Interior) Glazing Stops: Removable, coordinated with glazing indicated.
- F. Welding: Weld components to comply with referenced AWS standard. To greatest extent possible, weld before finishing and in concealed locations to minimize distortion or discoloration of finish. Remove weld spatter and welding oxides from exposed surfaces by descaling or grinding.
- G. Metal Protection: Separate dissimilar metals to protect against galvanic action by painting contact surfaces with primer or by applying sealant or tape recommended by manufacturer for this purpose.
- H. Factory-cut openings in glazing for speaking apertures.
- I. Preglazed Fabrication: Preglaze window units at factory, where required for applications indicated. Installation orientation of glazing to meet performance requirements. Comply with requirements in Section 088853 "Security Glazing."
- J. Weather Stripping: Factory applied.

2.4 GENERAL FINISH REQUIREMENTS

- A. Comply with NAAMM/NOMMA 500 for recommendations for applying and designating finishes.
- B. Protect mechanical finishes on exposed surfaces from damage by applying a strippable, temporary protective covering before shipping.
- C. Appearance of Finished Work: Noticeable variations in same piece are not acceptable. Variations in appearance of adjoining components are acceptable if they are within the range of approved Samples and are assembled or installed to minimize contrast.

2.5 ALUMINUM FINISHES

- A. Clear Anodic Finish: AAMA 611, AA-M12C22A41, Class I, 0.018 mm or thicker.
- B. Color Anodic Finish: AAMA 611, AA-M12C22A42/A44, Class I, 0.018 mm or thicker.
 - 1. Color: See Finish Schedule.

2.6 ACCESSORIES

- A. Recessed Deal Trays: Formed from stainless steel with sliding stainless steel cover; fabricated in curved shape with exposed flanges for recessed installation into horizontal surface.
 - 1. Clear Opening Size: **12 inches wide by 8 inches deep by 1-1/2 inches high.**
- B. Speaker
 - 1. Basis-of-Design Product: Subject to compliance with requirements, provide Amortex; ANVS-6 Natural Voice Speaker
 - a. Shape: Circular
 - b. Ballastics Resistance: Same as security window.
- C. Concealed Bolts: ASTM A307, Grade A unless otherwise indicated.
- D. Cast-in-Place Anchors in Concrete: Fabricated from corrosion-resistant materials capable of sustaining, without failure, a load equal to four times the load imposed, as determined by testing in accordance with ASTM E488/E488M, conducted by a qualified testing agency; of type indicated below.
 - 1. Threaded or wedge type; galvanized ferrous castings, either ASTM A27/A27M cast steel or ASTM A47/A47M malleable iron. Provide bolts, washers, and shims as required; hot-dip galvanized in accordance with ASTM A153/A153M or ASTM F2329/F2329M.
- E. Embedded Plate Anchors: Fabricated from mild steel shapes and plates, minimum **3/16 inch** thick; with minimum **1/2-inch** diameter, headed studs welded to back of plate.
- F. Welding Rods and Bare Electrodes: Select in accordance with AWS specifications for metal alloy welded.
- G. Glazing Strips and Weather Stripping: Manufacturer's standard replaceable components.
 - 1. Compression Type: Molded EPDM or neoprene gaskets complying with ASTM D2000, Designations 2BC415 to 3BC620; molded PVC gaskets complying with ASTM D2287; or molded, expanded EPDM or neoprene gaskets complying with ASTM C509, Grade 4.

2. Sliding Type: AAMA 701/702, made of wool, polypropylene, or nylon woven pile with nylon-fabric backing.
- H. Miscellaneous Glazing Materials: Provide material, size, and shape complying with requirements of glass manufacturers and with a proven record of compatibility with surfaces contacted in installation.
1. Cleaners, Primers, and Sealers: Type recommended by sealant or gasket manufacturer.
 2. Setting Blocks: Elastomeric material with a Shore A durometer hardness of 85, plus or minus 5.
 3. Spacers: Elastomeric blocks or continuous extrusions with a Shore A durometer hardness required by glass manufacturer to maintain glass lites in place for installation indicated.
 4. Edge Blocks: Elastomeric material of hardness needed to limit glass lateral movement (side walking).
- I. Anchors, Clips, and Window Accessories: Stainless steel; hot-dip, zinc-coated steel or iron, complying with ASTM B633; provide sufficient strength to withstand design pressures indicated.
- J. Bituminous Paint: Cold-applied asphalt emulsion complying with ASTM D1187/D1187M.
- K. Sealants: For sealants required within fabricated security windows, provide type recommended by manufacturer for joint size and movement. Sealant remains permanently elastic, nonshrinking, and nonmigrating.

PART 3 - EXECUTION

3.1 INSTALLATION

- A. Fastening to In-Place Construction: Provide anchorage devices and fasteners where necessary for securing security windows to in-place construction. Include threaded fasteners for inserts, security fasteners, and other connectors.
1. Install an attached or integral flange to secure side of security windows extending over rough-in opening gap so that gap has same forced-entry-resistance performance as security window.
- B. Glazed Framing: Provide gasket-glazed framing. Comply with installation requirements in Section 088853 "Security Glazing."
- C. Removable Glazing Stops and Trim: Fasten components with security fasteners.
- D. Fasteners: Install security windows using fasteners recommended by manufacturer with head style appropriate for installation requirements, strength, and finish of adjacent materials. Provide stainless steel fasteners in stainless steel materials.

- E. Sealants: Comply with requirements in Section 079200 "Joint Sealants" for installing sealants, fillers, and gaskets.
 - 1. Set continuous sill members and flashing in a full sealant bed to provide weathertight construction unless otherwise indicated.
 - 2. Seal frame perimeter with sealant to provide weathertight construction unless otherwise indicated.

- F. Metal Protection: Where dissimilar metals will contact each other, protect against galvanic action by painting contact surfaces with primer or by applying sealant or tape recommended in writing by manufacturer for this purpose. Where aluminum will contact concrete or masonry, protect against corrosion by painting contact surfaces with bituminous paint.

3.2 FIELD QUALITY CONTROL

- A. Inspect installed products to verify compliance with requirements. Prepare inspection reports and indicate compliance with and deviations from the Contract Documents.
- B. Perform additional inspections to determine compliance of replaced or additional work. Prepare inspection reports.
- C. Prepare field quality-control certification that states installed products and their installation comply with requirements in the Contract Documents.

END OF SECTION 085653

SECTION 087100 - DOOR HARDWARE

1. GENERAL

1. SUMMARY

A. Section Inclusions:

1. Manual & Electrified Door Hardware
2. Finish Hardware as specified, scheduled, shown or required herein unless specifically excluded from this section.
3. Field verification, preparation and modification of existing doors and frames to receive new door hardware.

B. Specific Omissions:

1. Casework & Cabinet Hardware
2. Access Control Hardware & Cylinders
3. Fencing & Gate Hardware

C. Related Requirements:

1. Section 064100 "Architectural Wood Casework" for cabinet door hardware provided with cabinets.
2. Section 081113 "Hollow Metal Doors and Frames" .
3. Section 081173 "Sliding Metal Fire Doors" for door and track preparation, reinforcement, and motorized operators provided as part of automatic-closing assemblies.
4. Section 081213 "Hollow Metal Frames" .
5. Section 081216 "Aluminum Frames" for door silencers provided as part of aluminum frames.
6. Section 081416 "Flush Wood Doors" for
7. Section 083323 "Overhead Coiling Doors" for door hardware provided as part of overhead coiling door assemblies.
8. Section 083326 "Overhead Coiling Grilles" .
9. Section 084213 "Aluminum -Framed Entrances " for entrance door hardware, .
10. Section 087113 "Power Door Operators" for low-energy power operators and low-energy power-assist operators.

11. Division 26 "Electrical" sections for connections to electrical power system & low voltage wiring. low-voltage wiring
12. Section 284600 "Communication Alarm System" for connections to building fire alarm system.

2. REFERENCES & STANDARDS

A. UL, LLC

1. UL 10B - Fire Test of Door Assemblies
2. UL 10C - Positive Pressure Test of Fire Door Assemblies
3. UL 1784 - Air Leakage Tests of Door Assemblies
4. UL 305 - Panic Hardware

B. DHI - Door and Hardware Institute

1. Sequence & Format for the Hardware Schedule
2. Keying Systems & Nomenclature
3. Installation Guide for Doors and Hardware

C. ANSI - American National Standards Institute

1. ANSI/BHMA A156.1 - A156.29, ANSI /BHMA A156.31 - Standards for Hardware & Specialties
2. ANSI A117.1-2017 - Accessible and Usable Buildings & Facilities

3. COORDINATION

- A. Security: Coordinate installation of door hardware, keying, and access control with Owner's security consultant.
- B. Electrical System Roughing-In: Coordinate layout and installation of electrified door hardware with connections to power supplies and building safety and security systems.
- C. Existing Openings: Where hardware components are scheduled for application to existing construction or where modifications to existing door hardware are required, field-verify existing conditions and coordinate installation of door hardware to suit opening conditions and to provide proper door operation.

4. PREINSTALLATION MEETINGS

- A. Preinstallation Conference: Conduct conference at Project site.

1. Conference participants must include Installer's Architectural Hardware Consultant and Owner's security consultant.

5. ACTION SUBMITTALS

A. Product Data:

1. Submit construction details, material descriptions, dimensions of individual components and profiles, finishes, and any other information necessary to show compliance with requirements.

B. Shop Drawings: For electrified door hardware.

1. Include diagrams for power, signal, and control wiring.
2. Include details of interface of electrified door hardware and building safety and security systems.
3. Point-to-Point Wiring

C. Door Hardware Schedule: Coordinate door hardware schedule with doors, frames, and related work to ensure proper size, thickness, hand, function, and finish of door hardware.

1. Submittal Sequence: Submit door hardware schedule concurrent with submissions of product data, Samples, and Shop Drawings. Coordinate submission of door hardware schedule with scheduling requirements of other work to facilitate the fabrication of other work that is critical in Project construction schedule.
2. Format: Use same scheduling sequence and format and use same door numbers as in door hardware schedule in the Contract Documents.
3. Content: Include the following information:
 - a. Identification number, location, hand, fire rating, size, and material of each door and frame.
 - b. Locations of each door hardware set, cross-referenced to Drawings on floor plans and to door and frame schedule.
 - c. Complete designations, including name and manufacturer, type, style, function, size, quantity, function, and finish of each door hardware product.
 - d. Description of electrified door hardware sequences of operation and interfaces with other building control systems.
 - e. Explanation of abbreviations, symbols, and designations contained in door hardware schedule.
 - f. List of related door devices specified in other Sections for each door and frame.

vendor. Can inspect and verify components are in working order upon completion of installation. .

9. WARRANTY

- A. Special Warranty: Manufacturer agrees to repair or replace components of door hardware that fail in materials or workmanship within specified warranty period.
 - 1. Failures include, but are not limited to, the following:
 - a. Faulty operation of doors and door hardware.
 - b. Deterioration of metals, metal finishes, and other materials beyond normal weathering and use.
 - 2. Warranty Period: years from date of Substantial Completion or for duration as indicated in manufacturer's published listings and warranties.

10. MAINTENANCE

- A. Furnish a complete set of any special tools required for maintenance and adjustment of hardware, including changing of cylinders.
- B. Deliver any unused materials to Owner for maintenance /attic stock.

2. PRODUCTS

1. PERFORMANCE REQUIREMENTS

- A. Fire-Rated Door Assemblies: Where fire-rated doors are indicated, provide door hardware complying with NFPA 80 that is listed and labeled by a qualified testing agency, for fire-protection ratings indicated, based on testing at positive pressure in accordance with NFPA 252 or UL 10C.
- B. Electrified Door Hardware: Listed and labeled as defined in NFPA 70, by a qualified testing agency, and marked for intended location and application.
- C. Means of Egress Doors: Latches do not require more than **15 lbf** to release the latch. Locks do not require use of a key, tool, or special knowledge for operation.
- D. Accessibility Requirements: For door hardware on doors in an accessible route, comply with ICC A117.1.
 - 1. Provide operating devices that do not require tight grasping, pinching, or twisting of the wrist and that operate with a force of not more than **5 lbf**.
 - 2. Comply with the following maximum opening-force requirements:
 - a. Interior, Non-Fire-Rated Hinged Doors: **5 lbf** applied perpendicular to door.

- b. Sliding or Folding Doors: **5 lbf** applied parallel to door at latch.
 - c. Fire Doors: Minimum opening force allowable by authorities having jurisdiction.
 3. Bevel raised thresholds with a slope of not more than 1:2. Provide thresholds not more than **1/2 inch** high.
 4. Adjust door closer sweep periods so that, from an open position of 90 degrees, the door will take at least 5 seconds to move to a position of 12 degrees from the latch.
 5. Adjust spring hinges so that, from an open position of 70 degrees, the door will take at least 1.5 seconds to move to the closed position.

2. HINGES

A. Hinges: ANSI/BHMA A156.1 Conforming

1. Basis-of-Design Product: Subject to compliance with requirements, provide product as noted in Door Hardware schedule or comparable product by one of the following:
 - a. Ives, Allegion US
 - b. Hager Companies
 - c. Best Access, Dormakaba

3. MECHANICAL LOCKS AND LATCHES

A. Mortise Locks: ANSI/BHMA A156.13, stamped steel case with steel or brass parts; Series 1000.

1. Basis-of-Design Product: Subject to compliance with requirements, provide product as noted in Door Hardware schedule or comparable product by one of the following:
 - a. Schlage, Allegion US
2. Lever Trim: Solid brass, bronze, or stainless steel, cast or forged in design specified, with wrought roses and external lever spring cages. Provide thru-bolted levers with 2-piece spindles

4. ELECTRIC STRIKES

A. Electric Strikes: ANSI/BHMA A156.31, Grade 1; with faceplate to suit lock and frame.

1. Basis-of-Design Product: Subject to compliance with requirements, provide product as noted in Door Hardware schedule or comparable product by one of

the following:

- a. Schlage, Allegion US
 - b. Von Duprin
2. Provide electric strikes designed for use with type of locks shown at each opening. Coordinate with Owner's access control vendor to confirm compatibility with Card Readers & Access Control system. Where required, provide electric strikes UL Listed for fire doors and frames.

5. EXIT DEVICES AND AUXILIARY ITEMS

A. Exit Devices and Auxiliary Items: ANSI/BHMA A156.3, Grade 1 & UL Listed

1. Basis-of-Design Product: Subject to compliance with requirements, provide product as noted in Door Hardware schedule or comparable product by one of the following:
 - a. Von Duprin
 - b. Hager
 - c. Adams-Rite
2. Provide exit devices with deadlatching feature for security and for future addition of alarm kits and/or other electrified requirements.
3. Provide electrified options as scheduled.
4. Provide exit devices with manufacturer's approved strikes.

6. KEYSWITCHES

A. Basis-of-Design Product: Subject to compliance with requirements, provide product as noted in Door Hardware schedule for Overhead Coiling Grille:

1. Schlage 650 Series
- B. Provide key switch capable of being configured to momentary or maintained action.
 - C. Provide key switch that accepts a replaceable mortise cylinder for owner keying.

7. LOCK CYLINDERS

- A. Standard Lock Cylinders: ANSI/BHMA A156.5
- B. Construction Master Keys: Provide cylinders with feature that permits voiding of construction keys without cylinder removal. Provide 10 construction master keys.

- C. Construction Cores: Provide construction cores that are replaceable by permanent cores.
8. ACCESSORIES FOR PAIRS OF DOORS
- A. Coordinators: ANSI/BHMA A156.3; consisting of active-leaf, hold-open lever, and inactive-leaf release trigger; fabricated from steel with nylon-coated strike plates; with built-in, adjustable safety release.
 - B. Carry-Open Bars: ANSI/BHMA A156.3; prevent the inactive leaf from opening before the active leaf; provide polished brass or bronze carry-open bars with strike plate for inactive leaves of pairs of doors unless automatic or self-latching bolts are used.
 - C. Astragals: ANSI/BHMA A156.22.
9. SURFACE CLOSERS
- A. Basis-of-Design Product: Subject to compliance with requirements, provide product as noted in Door Hardware schedule or comparable product by one of the following:
 - 1. LCN, Allegion
 - B. ANSI/BHMA A156.4; rack-and-pinion hydraulic type with adjustable sweep and latch speeds controlled by key-operated valves and forged-steel main arm. Comply with manufacturer's written instructions for size of door closers depending on size of door, exposure to weather, and anticipated frequency of use. Provide factory-sized closers, adjustable to meet field conditions and requirements for opening force.
10. MECHANICAL STOPS, HOLDERS and SILENCERS
- A. Wall- and Floor-Mounted Stops: ANSI/BHMA A156.16.
 - B. Basis-of-Design Product: Subject to compliance with requirements, provide product as noted in Door Hardware schedule or comparable product by one of the following:
 - 1. Ives
 - 2. Trimco
 - 3. Burns
 - C. Provide wall stops wherever possible. Provide concave type where lockset has a push button or thumbturn.
 - D. Provide "push-in" type silencers for hollow metal or wood frames. Provide one silencer per 30 inches (762 mm) of height on each single frame, and two for each pair frame. Omit where gasketing is specified.
11. THRESHOLDS, GUARDS, SWEEPS and GASKETING

- A. Basis-of-Design Product: Subject to compliance with requirements, provide product as noted in Door Hardware schedule or comparable product by one of the following:

1. Zero International
2. Reese

12. ELECTROMAGNETIC STOPS AND HOLDERS

- A. Electromagnetic Door Holders: ANSI/BHMA A156.15, Grade 1; wall-mounted electromagnetic double unit with strike plate attached to swinging door; coordinated with fire detectors and interfaced with fire-alarm system for labeled fire-rated door assemblies.
- B. Basis-of-Design Product: Subject to compliance with requirements, provide product as noted in Door Hardware schedule or comparable product.

13. THRESHOLDS

- A. Thresholds: ANSI/BHMA A156.21; fabricated to full width of opening indicated.

14. SLIDING DOOR HARDWARE

- A. Sliding Door Hardware: ANSI/BHMA A156.14; consisting of complete sets, including rails, hangers, supports, bumpers, floor guides, and accessories indicated.
1. Basis-of-Design Product: Subject to compliance with requirements, provide Dormakaba Muto Comfort L80 for Wood Doors or comparable product by one of the following:
 - a. Arthur Cox & Sons, Inc.
 - b. Hager Companies
 - c. Hettich America L.P.
 - d. Johnson, L. E., Products, Inc
 - e. K.N. Crowder Mfg. Inc
 - f. PC Henderson Inc.
 - g. CR Laurence, Inc.
 - h. PEMKO, Assa Abloy
 - i. Hafele America Co.
 - j. STANLEY; dormakaba USA, Inc.

15. FABRICATION

- A. Base Metals: Produce door hardware units of base metal indicated, fabricated by forming method indicated, using manufacturer's standard metal alloy, composition, temper, and hardness. Furnish metals of a quality equal to or greater than that of specified door hardware units and ANSI/BHMA A156.18.
- B. Fasteners: Provide door hardware manufactured to comply with published templates prepared for machine, wood, and sheet metal screws. Provide screws that comply with commercially recognized industry standards for application intended; however, aluminum fasteners are not permitted. Provide Phillips flat-head screws with finished heads to match surface of door hardware unless otherwise indicated.
 - 1. Concealed Fasteners: For door hardware units that are exposed when door is closed, except for units already specified with concealed fasteners. Do not use through bolts for installation where bolt head or nut on opposite face is exposed unless it is the only means of securely attaching the door hardware. Where through bolts are used on hollow door and frame construction, provide sleeves for each through bolt.
 - 2. Fire-Rated Applications:
 - a. Wood or Machine Screws: For the following:
 - 1) Hinges mortised to doors or frames.
 - 2) Strike plates to frames.
 - 3) Closers to doors and frames.
 - b. Steel Through Bolts: For the following unless door blocking is provided:
 - 1) Surface hinges to doors.
 - 2) Closers to doors and frames.
 - 3) Surface-mounted exit devices.
 - 3. Spacers or Sex Bolts: For through bolting of hollow-metal doors.
 - 4. Gasketing Fasteners: Provide noncorrosive fasteners for exterior applications and elsewhere as indicated.

16. FINISHES

- A. Provide finishes complying with ANSI/BHMA A156.18 as indicated in door hardware schedule.

3. EXECUTION

1. EXAMINATION

- A. Prior to installation of hardware, examine doors and frames, with Installer present, for compliance with requirements for installation tolerances, labeled fire-rated door assembly construction, wall and floor construction, and other conditions affecting performance. Verify doors, frames, and walls have been properly reinforced for hardware installation.
- B. Field verify existing doors and frames receiving new hardware and existing conditions receiving new openings. Verify that new hardware is compatible with existing door and frame preparation and existing conditions
- C. Examine roughing-in for electrical power systems to verify actual locations of wiring connections before electrified door hardware installation.
- D. Submit a list of deficiencies in writing and proceed with installation only after unsatisfactory conditions have been corrected.

2. PREPARATION

- A. Where onsite modification of doors and frames is required:
 - 1. Carefully remove existing door hardware and components being reused. Clean, protect, tag, and store in accordance with storage and handling requirements specified herein.
 - 2. Field modify and prepare existing doors and frames for new hardware being installed.
 - 3. When modifications are exposed to view, use concealed fasteners, when possible.
 - 4. Prepare hardware locations and reinstall in accordance with installation requirements for new door hardware and with:
 - a. Steel Doors and Frames: For surface applied door hardware, drill and tap doors and frames according to ANSI/SDI A250.6.
 - b. Wood Doors: DHI WDHS.5 "Recommended Hardware Reinforcement Locations for Mineral Core Wood Flush Doors."
 - c. Doors in rated assemblies: NFPA 80 for restrictions on on-site door hardware preparation.

3. INSTALLATION OF DOOR HARDWARE

- A. Mounting Heights: Mount door hardware units at heights to comply with the following unless otherwise indicated or required to comply with governing regulations.
 - 1. Standard Steel Doors and Frames: ANSI/SDI A250.8.

2. Custom Steel Doors and Frames: HMMA 831.
 3. Interior Architectural Wood Flush Doors: ANSI/WDMA I.S. 1A
 4. Wood Doors: DHI's "Recommended Locations for Architectural Hardware for Wood Flush Doors."
- B. Finish exposed screws to match hardware finish or if hardware is in the finish of other work, to match finish of other work including paint colors. Provide concealed fasteners wherever possible for hardware units exposed when doors are closed.
- C. Install door hardware in accordance with NFPA 80, NFPA 101 and provide post-install inspection, testing as specified in section 1.03.E unless otherwise required to comply with governing regulations.
- D. Install each door hardware item to comply with manufacturer's written instructions. Where cutting and fitting are required to install door hardware onto or into surfaces that are later to be painted or finished in another way, coordinate removal, storage, and reinstallation of surface protective trim units with finishing work. Do not install surface-mounted items until finishes have been completed on substrates involved.
1. Set units level, plumb, and true to line and location. Adjust and reinforce attachment substrates as necessary for proper installation and operation.
 2. Drill and countersink units that are not factory prepared for anchorage fasteners. Space fasteners and anchors in accordance with industry standards.
- E. Hinges: Install types and in quantities indicated in door hardware schedule, but not fewer than the number recommended by manufacturer for application indicated or one hinge for every **30 inches** of door height, whichever is more stringent, unless other equivalent means of support for door, such as spring hinges or pivots, are provided.
- F. Intermediate Offset Pivots: Where offset pivots are indicated, provide intermediate offset pivots in quantities indicated in door hardware schedule, but not fewer than one intermediate offset pivot per door and one additional intermediate offset pivot for every **30 inches** of door height greater than **90 inches**
- G. Wiring: Coordinate with Division 26, ELECTRICAL and Division 28 ELECTRONIC SAFETY AND SECURITY sections for:
1. Conduit, junction boxes and wire pulls.
 2. Connections to and from power supplies to electrified hardware.
 3. Connections to fire/emergency alarm system.
 4. Connections to panel interface modules and controllers.
 5. Testing and labeling wires with Architect's opening number.
- H. Lock Cylinders: Install construction cores to secure building and areas during construction period.

- I. Continuous Hinges: Re-locate the door and frame fire rating labels where they will remain visible so that the hinge does not cover the label once installed.
 - J. Boxed Power Supplies: Locate power supplies as indicated or, if not indicated, above accessible ceilings or in Owner's equipment room. Verify location with Architect.
 - K. Thresholds: Set thresholds for exterior doors and other doors indicated in full bed of sealant complying with requirements specified in Section 079200 "Joint Sealants."
 - L. Perimeter Gasketing: Apply to head and jamb, forming seal between door and frame.
 - 1. Do not notch perimeter gasketing to install other surface-applied hardware.
 - M. Meeting Stile Gasketing: Fasten to meeting stiles, forming seal when doors are closed.
 - N. Door Bottoms: Apply to bottom of door, forming seal with threshold when door is closed.
4. ADJUSTING
- A. Initial Adjustment: Adjust and check each operating item of door hardware and each door to ensure proper operation or function of every unit. Replace units that cannot be adjusted to operate as intended. Adjust door control devices to compensate for final operation of heating and ventilating equipment and to comply with referenced accessibility requirements.
 - 1. Electric Strikes: Adjust horizontal and vertical alignment of keeper to properly engage lock bolt.
 - 2. Door Closers: Adjust sweep period & operating force to comply with accessibility requirements and requirements of authorities having jurisdiction.
5. DOOR HARDWARE SCHEDULE
- A. The intent of the hardware specification is to specify the hardware for interior and exterior doors, and to establish a type, continuity, and standard of quality. However, it is the door hardware supplier's responsibility to thoroughly review existing conditions, schedules, specifications, drawings, and other Contract Documents to verify the suitability of the hardware specified.
 - B. Discrepancies, conflicting hardware, and missing items are to be brought to the attention of the architect with corrections made prior to the bidding process. Omitted items not included in a hardware set should be scheduled with the appropriate additional hardware required for proper application.
 - C. Hardware items are referenced in the following hardware schedule. Refer to the above specifications for special features, options, cylinders/keying, and other requirements.
 - D. Hardware Sets:

HARDWARE SET B WOOD 3-0 X 7-0

Doors: 100, 101, 105, 106, 107, 110, 112, 113, 137, 140, 149, 150, 151, 167, 169, 176, 182A, 183, 184, 186, 187, 192, 194, 215, 216, 218, 255, 256, 258A, 258B, 259, 303, 305, 306

Each to receive:

3	EA	Hinge, Full Mortise	TA2714 NRP 4-1/2" x 4-1/2" US26D	MK
1	EA	Office/Entry Lock	63 8255 LNP US26D	SA
1	EA	Wall Stop	409 US32D	RO
3	EA	Silencer	608-RKW	RO

HARDWARE SET B.1 EXISTING WOOD 3-0 X 7-0

Doors: E257, E304, E316, E317, E319, E321

Each to receive:

3	EA	Hinge, Full Mortise	TA2714 NRP 4-1/2" x 4-1/2" US26D	MK
1	EA	Office/Entry Lock	63 8255 LNP US26D	SA
1	EA	Wall Stop	409 US32D	RO
3	EA	Silencer	608-RKW	RO

HARDWARE SET C EXISTING HMD 3-0 X 7-0

Doors: E103, E161, E179, ES1A

Each to receive:

1	EA	Continuous Hinge	CFM83HD1	PE
1	EA	Rim Exit Device	63 8804 862 US32D	SA
1	EA	Rim Cylinder	6334 US32D MK	SA
1	EA	Electric Strike	9500 630	HS
1	EA	Door Pull	BF157 Mtg-Type 12XHD US32D	RO
1	EA	Surface Closer	351 CPS EN	SA
1	EA	Threshold	424 x 36"	NG
1	EA	Gasketing	160VA x 36" x 84"	NG
1	EA	Sweep	102VA x 36"	NG
1	EA	CARD READER	CR BY SECURITY CONTR	OT

HARDWARE SET D
WOOD 3-0 X 7-0

Doors: 102, 188, 189, 310
Each to receive:

3	EA	Hinge, Full Mortise	TA2714 NRP 4-1/2" x 4-1/2" US26D	MK
1	EA	Privacy Lock	V10 8265 LNP US26D	SA
1	EA	Surface Closer	351 CPS EN	SA
1	EA	Wall Stop	409 US32D	RO
3	EA	Silencer	608-RKW	RO

HARDWARE SET D.1 EXISTING WOOD 3-0 X 7-0

Doors: E309, E326, E327, E328, E346, E363
Each to receive:

3	EA	Hinge, Full Mortise	TA2714 NRP 4-1/2" x 4-1/2" US26D	MK
1	EA	Privacy Lock	V10 8265 LNP US26D	SA
1	EA	Surface Closer	351 CPS EN	SA
1	EA	Wall Stop	409 US32D	RO

HARDWARE SET G WOOD 3-0 X 7-0

Doors: 163, 164, 165B, 181, 185, 324, S2B
Each to receive:

1	EA	Continuous Hinge	CFM83HD1	PE
1	EA	Rim Exit Device	63 8813 ETL US32D	SA
1	EA	Rim Cylinder	6334 US32D MK	SA
1	EA	Electric Strike	9500 630	HS
1	EA	Surface Closer	351 CPS EN	SA
3	EA	Silencer	608-RKW	RO
1	EA	CARD READER	CR BY SECURITY CONTR	OT

HARDWARE SET G.1 EXISTING WOOD 3-0 X 7-0

Doors: E332A, E336F, E364, E365
Each to receive:

1	EA	Continuous Hinge	CFM83HD1	PE
1	EA	Rim Exit Device	63 8813 ETL US32D	SA
1	EA	Rim Cylinder	6334 US32D MK	SA
1	EA	Electric Strike	9500 630	HS
1	EA	Surface Closer	351 CPS EN	SA

DOOR HARDWARE

087100 - 15

3	EA	Silencer	608-RKW	RO
1	EA	CARD READER	CR BY SECURITY CONTR	OT

HARDWARE SET G.2 EXISTING WOOD PAIR 3-0 X 7-0

Doors: E303A, E323
Each to receive:

2	EA	Continuous Hinge	CFM83HD1	PE
1	EA	Mullion	980S 86" PC	SA
2	EA	Rim Exit Device	63 8813 ETL US32D	SA
2	EA	Rim Cylinder	6334 US32D MK	SA
2	EA	Electric Strike	9500 630	HS
2	EA	Surface Closer	351 CPS EN	SA
2	EA	Silencer	608-RKW	RO
2	EA	CARD READER	CR BY SECURITY CONTR	OT

HARDWARE SET H WOOD 3-0 X 7-0 (60)

Doors: 191C
Each to receive:

1	EA	Continuous Hinge	CFM83HD1	PE
1	EA	Rim Exit Device	12 63 8813 ETL US32D	SA
1	EA	Rim Cylinder	6334 US32D MK	SA
1	EA	Surface Closer	351 CPS EN	SA
1	EA	Wall Stop	409 US32D	RO
1	EA	Gasketing	5050C x 36" x 84"	NG

HARDWARE SET H.1 EXISTING WOOD (60)

Doors: ES1B, ES1C
Each to receive:

1	EA	Continuous Hinge	CFM83HD1	PE
1	EA	Rim Exit Device	12 63 8813 ETL US32D	SA
1	EA	Rim Cylinder	6334 US32D MK	SA
1	EA	Surface Closer	351 CPS EN	SA

DOOR HARDWARE

087100 - 16

1	EA	Wall Stop	409 US32D	RO
1	EA	Gasketing	5050C x 36" x 84"	NG

HARDWARE SET H.2 EXISTING WOOD PAIR 3-0 X 7-0

Doors: E221
Each to receive:

2	EA	Continuous Hinge	CFM83HD1	PE
2	EA	Rim Exit Device	63 8813 ETL US32D	SA
2	EA	Rim Cylinder	6334 US32D MK	SA
2	EA	Surface Closer	351 CPS EN	SA
2	EA	Wall Stop	409 US32D	RO
2	EA	Silencer	608-RKW	RO

HARDWARE SET J WOOD/HMD 3-0 X 7-0

Doors: 109, 147A, 147B, 154, 165A, 166, 214, 220, 260, 261, 329, 337, 338
Each to receive:

3	EA	Hinge, Full Mortise	TA2714 NRP 4-1/2" x 4-1/2" US26D	MK
1	EA	Passage Latch	8215 LNP US26D	SA
1	EA	Wall Stop	409 US32D	RO
1	EA	Door Stop	461 US26D	RO
3	EA	Silencer	608-RKW	RO

HARDWARE SET J.1 EXISTING WOOD 3-0 X 7-0

Doors: E334, E334A, E335, E335A
Each to receive:

3	EA	Hinge, Full Mortise	TA2714 NRP 4-1/2" x 4-1/2" US26D	MK
1	EA	Passage Latch	8215 LNP US26D	SA
1	EA	Wall Stop	409 US32D	RO
1	EA	Door Stop	461 US26D	RO
3	EA	Silencer	608-RKW	RO

HARDWARE SET J.2 WOOD/HMD PAIR 3-0 X 7-0

Doors: 119, 314, 341
Each to receive:

6	EA	Hinge, Full Mortise	TA2714 NRP 4-1/2" x 4-1/2" US26D	MK
---	----	---------------------	----------------------------------	----

DOOR HARDWARE

087100 - 17

Intersect Studio, LLC
23046

Kalamazoo Crosstown
Parkway Facility
Kalamazoo, Michigan

2	EA	Flush Bolt	557 US26D	RO
1	EA	Dust Proof Strike	570 US26D	RO
1	EA	Passage Latch	8215 LNP US26D	SA
2	EA	Wall Stop	409 US32D	RO
2	EA	Door Stop	461 US26D	RO
2	EA	Silencer	608-RKW	RO

HARDWARE SET J.3 EXISTING WOOD PAIR 3-0 X 7-0

Doors: E264, E301

Each to receive:

6	EA	Hinge, Full Mortise	TA2714 NRP 4-1/2" x 4-1/2" US26D	MK
2	EA	Flush Bolt	557 US26D	RO
1	EA	Dust Proof Strike	570 US26D	RO
1	EA	Passage Latch	8215 LNP US26D	SA
2	EA	Wall Stop	409 US32D	RO
2	EA	Door Stop	461 US26D	RO
2	EA	Silencer	608-RKW	RO

HARDWARE SET K WOOD 10-0 X 7-0 (BIFOLD PAIR)

Doors: 106B

Each to receive:

1	EA	Hardware Set	200FD962	JO
1	EA	Single Dummy Trim	8295 LNP US26D	SA

HARDWARE SET L WOOD/HMD 3-0 X 7-0

Doors: 146, 153, 179A, 179B, 182B, 302, 339

Each to receive:

3	EA	Hinge, Full Mortise	TA2714 NRP 4-1/2" x 4-1/2" US26D	MK
1	EA	Storeroom/Closet Lock	63 8204 LNP US26D	SA
1	EA	Electric Strike	1006CS-F 630	HS
1	EA	Surface Closer	351 CPS EN	SA
1	EA	Wall Stop	409 US32D	RO
3	EA	Silencer	608-RKW	RO
1	EA	CARD READER	CR BY SECURITY CONTR	OT

HARDWARE SET L.1 EXISTING WOOD 3-0 X 7-0

Doors: E302A, E311, E325, E347B, E347C

Each to receive:

3	EA	Hinge, Full Mortise	TA2714 NRP 4-1/2" x 4-1/2" US26D	MK
1	EA	Storeroom/Closet Lock	63 8204 LNP US26D	SA
1	EA	Electric Strike	1006CS-F 630	HS
1	EA	Surface Closer	351 CPS EN	SA
1	EA	Wall Stop	409 US32D	RO
3	EA	Silencer	608-RKW	RO
1	EA	CARD READER	CR BY SECURITY CONTR	OT

HARDWARE SET L.2 EXISTING WOOD PAIR 3-0 X 7-0

Doors: E160

Each to receive:

6	EA	Hinge, Full Mortise	TA2714 NRP 4-1/2" x 4-1/2" US26D	MK
2	EA	Flush Bolt	557 US26D	RO
1	EA	Dust Proof Strike	570 US26D	RO

DOOR HARDWARE

087100 - 19

1	EA	Storeroom/Closet Lock	63 8204 LNP US26D	SA
1	EA	Electric Strike	1006CS-F 630	HS
1	EA	Coordinator	COR52 628 FL20	IV
2	EA	Surface Closer	351 CPS EN	SA
2	EA	Wall Stop	409 US32D	RO
2	EA	Silencer	608-RKW	RO
1	EA	CARD READER	CR BY SECURITY CONTR	OT

HARDWARE SET L.3 WOOD PAIR 3-0 X 7-0

Doors: 347A

Each to receive:

6	EA	Hinge, Full Mortise	TA2714 NRP 4-1/2" x 4-1/2" US26D	MK
2	EA	Flush Bolt	557 US26D	RO
1	EA	Dust Proof Strike	570 US26D	RO
1	EA	Storeroom/Closet Lock	63 8204 LNP US26D	SA
1	EA	Electric Strike	1006CS-F 630	HS
1	EA	Coordinator	COR52 628 FL20	IV
2	EA	Surface Closer	351 CPS EN	SA
2	EA	Wall Stop	409 US32D	RO
2	EA	Silencer	608-RKW	RO
1	EA	CARD READER	CR BY SECURITY CONTR	OT

HARDWARE SET M EXISTING WOOD 3-0 X 7-0

Doors: E173, E174, E251, E253, E368, E369

Each to receive:

3	EA	Hinge, Full Mortise	TA2714 NRP 4-1/2" x 4-1/2" US26D	MK
1	EA	Push Plate	70C-RKW US32D	RO
1	EA	Pull Plate	110x70C US32D	RO
1	EA	Surface Closer	351 CPS EN	SA
1	EA	Kick Plate	K1050 10" x 34" US32D CSK BEV	RO
3	EA	Silencer	608-RKW	RO

HARDWARE SET N HMD PAIR 3-6 X 7-0 (60)

Doors: 191B
Each to receive:

6	EA	Hinge, Full Mortise	TA2714 NRP 4-1/2" x 4-1/2" US26D	MK
2	EA	Rim Exit Device	12 8815 G ETL US32D	SA
2	EA	Surface Closer	351 P10 EN	SA
2	EA	Wall Stop	409 US32D	RO
2	EA	Electromagnetic Holder	SEM7850 .689	LCC H
1	EA	Gasketing	5050C x 84" x 84"	NG

HARDWARE SET P WOOD 3-0 X 7-0 (60)

Doors: 177, 190
Each to receive:

3	EA	Hinge, Full Mortise	TA2714 NRP 4-1/2" x 4-1/2" US26D	MK
1	EA	Passage Latch	8215 LNP US26D	SA
1	EA	Surface Closer	351 CPS EN	SA
1	EA	Wall Stop	409 US32D	RO

END OF SECTION 087100

SECTION 087113 - POWER DOOR OPERATORS

PART 1 - GENERAL

1.1 SUMMARY

A. Section Includes:

1. Power door operators for swinging doors.

B. Related Requirements:

1. Section 033000 "Cast-in-Place Concrete" for installing recessed metal frames for control mats in concrete.
2. Section 084229.33 "Swinging Automatic Entrances" for swinging doors and frames packaged with power door operators.

1.2 ACTION SUBMITTALS

A. Product Data: For each type of product.

1. Include construction details, material descriptions, dimensions of individual components and profiles, and finishes for power door operators.
2. Include rated capacities, operating characteristics, electrical characteristics, and furnished specialties and accessories.

B. Shop Drawings: For power door operators.

1. Include plans, elevations, sections, hardware mounting heights, and attachment details.
2. Indicate dimensions, weights, loads, required clearances, method of field assembly, components, and location and size of each field connection.
3. Indicate locations of activation and safety devices.
4. Include diagrams for power, signal, and control wiring.
5. Include plans, elevations, sections, and attachment details for guide rails.

C. Samples: For each exposed product and for each color and texture specified, manufacturer's standard size.

1.3 INFORMATIONAL SUBMITTALS

- A. Product Certificates: For each type of power door operator. For each operator for fire-rated door assemblies, certify that operator is listed and labeled by a qualified testing agency acceptable to authorities having jurisdiction for use on types and sizes of labeled fire doors required.

- B. Field quality-control reports.
- C. Sample Warranties: For manufacturer's special warranties.

1.4 CLOSEOUT SUBMITTALS

- A. Maintenance Data: For power door operators, safety devices, and control systems, to include in maintenance manuals.

1.5 QUALITY ASSURANCE

- A. Installer Qualifications: An authorized representative who is trained and approved by manufacturer for installation and maintenance of units required for this Project.
- B. Certified Inspector Qualifications: Certified by AAADM.

1.6 WARRANTY

- A. Special Warranty: Manufacturer agrees to repair or replace components of power door operators that fail in materials or workmanship within specified warranty period.
 - 1. Failures include, but are not limited to, the following:
 - a. Faulty or sporadic operation of power door operator, including controls.
 - b. Deterioration of metals, metal finishes, and other materials beyond normal weathering or use.
 - 2. Warranty Period: Two years from date of Substantial Completion.

PART 2 - PRODUCTS

2.1 POWER DOOR OPERATORS, GENERAL

- A. Manufacturers: Subject to compliance with requirements, available manufacturers offering products that may be incorporated into the Work include, but are not limited to, the following:
 - 1. ASSA ABLOY Entrance Systems; ASSA ABLOY
 - 2. Ditec; Entrematic; ASSA ABLOY
 - 3. Door Motion Technologies, Inc.
 - 4. dormakaba USA Inc.
 - 5. Hager Companies
 - 6. Horton Automatics; Overhead Door Corporation
 - 7. KM Systems, Inc
 - 8. LCN; Allegion plc
 - 9. NABCO Entrances, Inc

10. Record USA; ASSA ABLOY
 11. SARGENT Manufacturing Company; ASSA ABLOY
 12. STANLEY Access Technologies LLC; STANLEY Security Solutions, Inc.
- B. Source Limitations: Obtain power door operators, including activation and safety devices, from same manufacturer as for hardware in Section 087100 "Door Hardware."
- C. General: Provide operators of size recommended by manufacturer for door size, weight, and movement; for condition of exposure; and for long-term, maintenance-free operation under normal traffic load for occupancy type indicated; and in accordance with UL 325. Coordinate operator mechanisms with door operation, hinges, and activation and safety devices.
1. Emergency Breakaway: Where indicated for center-pivoted doors, provide emergency breakaway feature for reverse swing of doors. Equip system to discontinue power to power door operator when door is in emergency breakaway position, to return door to closed position after breakaway, and to automatically reset.
 2. Wind Load: Provide door operators on exterior doors that will open and close doors and maintain them in fully closed position when subjected to wind load per Structural Drawings.
- D. Electromechanical Operating System: Self-contained unit powered by permanent-magnet dc motor; with closing speed controlled mechanically by gear train and dynamically by braking action of electric motor, connections for power and activation-and safety-device wiring, and manual operation, including spring closing when power is off.
- E. Hinges: See Section 087100 "Door Hardware" for hinge type for each door that door operator shall accommodate.
- F. Housing for Overhead Concealed Operators: Fabricated from minimum **0.125-inch**-thick, extruded or formed aluminum and extending full width of door opening, including door jambs, to conceal door operators and controls. Provide hinged or removable access panels for service and adjustment of door operators and controls. Secure panels to prevent unauthorized access.
- G. Brackets and Reinforcements: Fabricated from aluminum with nonstaining, nonferrous shims for aligning system components.
- H. Electrical Components, Devices, and Accessories: Listed and labeled as defined in NFPA 70, by a qualified testing agency, and marked for intended location and application.
- 2.2 MATERIALS
- A. Aluminum: Alloy and temper recommended by manufacturer for type of use and finish indicated.
1. Extrusions: **ASTM B221**.

2. Sheet: **ASTM B209**.

- B. Stainless Steel Sheet: ASTM A240/A240M or ASTM A666, Type 304, stretcher-leveled standard of flatness, in manufacturer's standard thickness.
- C. Brass Sheet: ASTM B36/B36M, Alloy UNS No. C26000 (cartridge brass, 70 percent copper), in manufacturer's standard thickness.
- D. Fasteners and Accessories: Corrosion-resistant, nonstaining, nonbleeding fasteners and accessories compatible with adjacent materials.

2.3 FABRICATION

- A. Factory fabricate power door operators to comply with indicated standards.
- B. Form aluminum shapes before finishing.
- C. Fabricate exterior components to drain condensation and water-passing joints within operator enclosure to the exterior.
- D. Use concealed fasteners to greatest extent possible. Where exposed fasteners are required, use countersunk Phillips flat-head machine screws, finished to match operator.
- E. Provide metal cladding, completely covering visible surfaces before shipment to Project site. Fabricate cladding with concealed fasteners and connection devices, with accurately fitted joints with ends coped or mitered to produce hairline joints free of burrs and distortion, and with allowance for thermal expansion at exterior doors.

2.4 GENERAL FINISH REQUIREMENTS

- A. Protect mechanical finishes on exposed surfaces from damage by applying strippable, temporary, protective covering before shipping.
- B. Apply organic and anodic finishes to formed metal after fabrication unless otherwise indicated.
- C. Appearance of Finished Work: Noticeable variations in same piece are unacceptable. Variations in appearance of adjoining components are acceptable if they are within range of approved Samples and are assembled or installed to minimize contrast.

2.5 ALUMINUM FINISHES

- A. Color Anodic Finish: AAMA 611, or thicker.

PART 3 - EXECUTION

3.1 INSTALLATION, GENERAL

- A. Install power door operators in accordance with manufacturer's written instructions and cited BHMA standard for type of door operation and direction of pedestrian travel, including signage, controls, wiring, remote power units if any, and connection to building's power supply.
 - 1. Do not install damaged components. Fit joints to produce hairline joints free of burrs and distortion.
 - 2. Install operators true in alignment with established lines and door geometry without warp or rack. Anchor securely in place.
- B. Controls: Install activation and safety devices in accordance with manufacturer's written instructions and cited BHMA standard for operator type and direction of pedestrian travel. Connect control wiring in accordance with Section 260519 "Low-Voltage Electrical Power Conductors and Cables."
- C. Access-Control System: Connect operators to access-control system as specified in Section 281500 "Access Control Hardware Devices."
- D. Signage: Apply on both sides of each door as required by cited BHMA standard for type of door operator and direction of pedestrian travel.
- E. Guide Rails: Install in accordance with BHMA A156.10, including Appendix A and manufacturer's written instructions unless otherwise indicated.

3.2 MAINTENANCE SERVICE

- A. Initial Maintenance Service: Beginning at Substantial Completion, maintenance service shall include 12 months' full maintenance by skilled employees of power door operator Installer. Include quarterly preventive maintenance, repair or replacement of worn or defective components, lubrication, cleaning, and adjusting as required for proper door operation. Parts and supplies shall be manufacturer's authorized replacement parts and supplies.
 - 1. Engage a Certified Inspector to perform safety inspection after each adjustment or repair and at end of maintenance period. Furnish completed inspection reports to Owner.
 - 2. Perform maintenance, including emergency callback service, during normal working hours.

3.3 DEMONSTRATION

- A. Engage a factory-authorized service representative to train Owner's maintenance personnel to adjust, operate, and maintain power door operators.

Intersect Studio, LLC
23046

Kalamazoo Crosstown
Parkway Facility
Kalamazoo, Michigan

END OF SECTION 087113

SECTION 088000 - GLAZING

PART 1 - GENERAL

1.1 SUMMARY

A. Section Includes:

1. Glass products.
2. Insulating glass.
3. Glazing tapes.

B. Related Requirements:

1. Section 057313 "Glazed Decorative Metal Railings" for glazing in railings.
2. Section 088300 "Mirrors."
3. Section 088853 "Security Glazing."

1.2 DEFINITIONS

- A. Glass Manufacturers: Firms that produce primary glass, fabricated glass, or both, as defined in referenced glazing publications.
- B. Glass Thicknesses: Indicated by thickness designations in millimeters in accordance with ASTM C1036.
- C. IBC: International Building Code.
- D. Interspace: Space between lites of an insulating-glass unit.

1.3 COORDINATION

- A. Coordinate glazing channel dimensions to provide necessary bite on glass, minimum edge and face clearances, and adequate sealant thicknesses, with reasonable tolerances to achieve proper safety margins for glazing retention under each design load case, load case combination, and service condition.

1.4 ACTION SUBMITTALS

- A. Product Data: For each type of product.
- B. Glass Samples: For each type of ; **12 inches** square.
- C. Glazing Schedule: List glass types and thicknesses for each size opening and location. Use same designations indicated on Drawings.

1.5 INFORMATIONAL SUBMITTALS

- A. Qualification Data: For Installer manufacturers of fabricated glass units glass testing agency and sealant testing agency.
- B. Sample Warranties: For special warranties.

1.6 QUALITY ASSURANCE

- A. Fabricated-Glass Manufacturer Qualifications: A qualified manufacturer of fabricated glass units who is approved by primary glass manufacturer.
- B. Certified by coated glass manufacturer.
- C. Installer Qualifications: A qualified glazing contractor for this Project who is certified under the North American Contractor Certification Program (NACC) for Architectural Glass & Metal (AG&M) contractors.
- D. Verify glass is free of chips, cracks, and other inclusions that could inhibit structural or aesthetic integrity.

1.7 DELIVERY, STORAGE, AND HANDLING

- A. Protect glazing materials in accordance with manufacturer's written instructions. Prevent damage to glass and glazing materials from condensation, temperature changes, direct exposure to sun, or other causes.

1.8 FIELD CONDITIONS

- A. Environmental Limitations: Do not proceed with glazing when ambient and substrate temperature conditions are outside limits permitted by glazing material manufacturers and when glazing channel substrates are wet from rain, frost, condensation, or other causes.
 - 1. Do not install glazing sealants when ambient and substrate temperature conditions are outside limits permitted by sealant manufacturer or are below **40 deg F**.

1.9 WARRANTY

- A. Manufacturer's Special Warranty for Coated-Glass Products: Manufacturer agrees to replace coated-glass units that deteriorate within specified warranty period. Deterioration of coated glass is defined as defects developed from normal use that are not attributed to glass breakage or to maintaining and cleaning coated glass contrary to manufacturer's written instructions. Defects include peeling, cracking, and other indications of deterioration in coating.

1. Warranty Period: 20 years from date of Substantial Completion.
- B. Manufacturer's Special Warranty for Laminated Glass: Manufacturer agrees to replace laminated-glass units that deteriorate within specified warranty period. Deterioration of laminated glass is defined as defects developed from normal use that are not attributed to glass breakage or to maintaining and cleaning laminated glass contrary to manufacturer's written instructions. Defects include edge separation, delamination materially obstructing vision through glass, and blemishes exceeding those allowed by referenced laminated-glass standard.
 1. Warranty Period: 10 years from date of Substantial Completion.

PART 2 - PRODUCTS

2.1 SOURCE LIMITATIONS

- A. Source Limitations for Glass: Obtain glass from single source from single manufacturer.
- B. Source Limitations for Glazing Accessories: For each product and installation method, obtain from single source from single manufacturer.

2.2 PERFORMANCE REQUIREMENTS

- A. General: Installed glazing systems shall withstand normal thermal movement and wind and impact loads (where applicable) without failure, including loss or glass breakage attributable to defective manufacture, fabrication, or installation; failure of sealants or gaskets to remain watertight and airtight; deterioration of glazing materials; or other defects in construction.
- B. Structural Performance: Glazing shall withstand the following design loads within limits and under conditions indicated determined in accordance with the IBC and ASTM E1300:
 1. Design Wind Pressures: As indicated on Drawings.
 - a. Wind Design Data: As indicated on Drawings.
 - b. Basic Wind Speed: 107 mph.
 - c. Importance Factor: 1.0.
 - d. Exposure Category: C.
 2. Design Snow Loads: As indicated on Drawings.
 3. Maximum Lateral Deflection: For glass supported on all four edges, limit center-of-glass deflection at design wind pressure to not more than 1/50 times the short-side length or **1 inch**, whichever is less.
 4. Thermal Loads: Design glazing to resist thermal stress breakage induced by differential temperature conditions and limited air circulation within individual glass lites and insulated glazing units.

- C. Safety Glazing: Where safety glazing is indicated, provide glazing that complies with 16 CFR 1201, Category II.
- D. Thermal and Optical Performance Properties: Provide glass with performance properties specified, as indicated in manufacturer's published test data, based on procedures indicated below:
 - 1. For monolithic-glass lites, properties are based on units with lites of thickness indicated.
 - 2. For laminated-glass lites, properties are based on products of construction indicated.
 - 3. For insulating-glass units, properties are based on units of thickness indicated for overall unit and for each lite.
 - 4. U-Factors: Center-of-glazing values, in accordance with NFRC 100 and based on most current non-beta version of LBL's WINDOW computer program, expressed as **Btu/sq. ft. x h x deg F**.
 - 5. SHGC and Visible Transmittance: Center-of-glazing values, in accordance with NFRC 200 and based on most current non-beta version of LBL's WINDOW computer program.
 - 6. Visible Reflectance: Center-of-glazing values, in accordance with NFRC 300.
- E. Acoustic Performance:
 - 1. Exterior Glazing: Per BOD Manufacturer and Product OITC.

2.3 GLASS PRODUCTS, GENERAL

- A. Glazing Publications: Comply with published recommendations of glass product manufacturers and organizations below unless more stringent requirements are indicated. See these publications for glazing terms not otherwise defined in this Section or in referenced standards.
 - 1. NGA Publications: "Laminated Glazing Reference Manual" and "Glazing Manual."
 - 2. AAMA Publications: AAMA GDSG-1, "Glass Design for Sloped Glazing," and AAMA TIR A7, "Sloped Glazing Guidelines."
 - 3. IGMA Publication for Sloped Glazing: IGMA TB-3001, "Guidelines for Sloped Glazing."
 - 4. IGMA Publication for Insulating Glass: SIGMA TM-3000, "North American Glazing Guidelines for Sealed Insulating Glass Units for Commercial and Residential Use."
- B. Safety Glazing Labeling: Where safety glazing is indicated, permanently mark glazing with certification label of the SGCC or another certification agency acceptable to authorities having jurisdiction. Label shall indicate manufacturer's name, type of glass, thickness, and safety glazing standard with which glass complies.
- C. Thickness: Where glass thickness is indicated, it is a minimum. Provide glass that complies with performance requirements and is not less than thickness indicated.

1. Minimum Glass Thickness for Exterior Lites: 6 mm.
2. Thickness of Tinted Glass: Provide same thickness for each tint color indicated throughout Project.

D. Strength: Where annealed float glass is indicated, provide annealed float glass, heat-strengthened float glass, or fully tempered float glass. Where heat-strengthened float glass is indicated, provide heat-strengthened float glass or fully tempered float glass as needed to comply with "Performance Requirements" Article. Where fully tempered float glass is indicated, provide fully tempered float glass.

2.4 GLASS PRODUCTS

A. Clear Annealed Float Glass (Interior): ASTM C1036, Type I, Class 1 (clear), Quality-Q3.

1. Manufacturers: Subject to compliance with requirements, provide products by one of the following:

- a. AGC Glass Company North America, Inc.
- b. Cardinal Glass Industries, Inc.
- c. Guardian Glass LLC
- d. Pilkington North America; NSG Group
- e. Vitro Architectural Glass

B. Fully Tempered Float Glass: ASTM C1048, Kind FT (fully tempered), Condition A (uncoated) unless otherwise indicated, Type I, Class 1 (clear) or Class 2 (tinted) as indicated, Quality-Q3.

C. Reflective- and Low-E-Coated Vision Glass (Glass for Tubelite 14000): ASTM C1376.

1. Basis-of-Design Product: Subject to compliance with requirements, provide Guardian Glass LLC: SunGuard SN 68 on Clear or comparable product by one of the following:

- a. Cardinal Glass Industries, Inc.
- b. Pilkington North America; NSG Group
- c. Vitro Architectural Glass

2. Design Components for Basis-of-Design Product:

- a. Vision glass, double glazed.
- b. Low-E Coating.
- c. Clear Tint.
- d. Visible Light Transmittance: 68%.
- e. Visible Light Reflectance Outdoors: 11%
- f. Solar Heat Gain Coefficient: 0.38.
- g. Laminated Glass, per Drawings.

2.5 INSULATING GLASS

- A. Insulating-Glass Units: Factory-assembled units consisting of sealed lites of glass separated by a dehydrated interspace, qualified in accordance with ASTM E2190.
 - 1. Sealing System: Dual seal, with manufacturer's standard primary and secondary sealants.
- B. General:
 - 1. Compatibility: Compatible with one another and with other materials they contact, including glass products, seals of insulating-glass units, and glazing channel substrates, under conditions of service and application, as demonstrated by sealant manufacturer based on testing and field experience.
 - 2. Suitability: Comply with sealant and glass manufacturers' written instructions for selecting glazing sealants suitable for applications indicated and for conditions existing at time of installation.
 - 3. Colors of Exposed Glazing Sealants: **[As indicated by manufacturer's designations][Match Architect's samples][As selected by Architect from manufacturer's full range of industry colors].**

2.6 GLAZING TAPES

- A. Back-Bedding Mastic Glazing Tapes: Preformed, butyl-based, 100 percent solids elastomeric tape; nonstaining and nonmigrating in contact with nonporous surfaces; with or without spacer rod as recommended in writing by tape and glass manufacturers for application indicated; and complying with ASTM C1281 and AAMA 800 for products indicated below:
 - 1. AAMA 804.3 tape, where indicated.
 - 2. AAMA 806.3 tape, for glazing applications in which tape is subject to continuous pressure.
 - 3. AAMA 807.3 tape, for glazing applications in which tape is not subject to continuous pressure.
- B. Expanded Cellular Glazing Tapes: Closed-cell, PVC foam tapes; factory coated with adhesive on both surfaces; and complying with AAMA 800 for the following types:
 - 1. AAMA 810.1, Type 1, for glazing applications in which tape acts as primary sealant.
 - 2. AAMA 810.1, Type 2, for glazing applications in which tape is used in combination with a full bead of liquid sealant.

2.7 MISCELLANEOUS GLAZING MATERIALS

- A. General: Provide products of material, size, and shape complying with referenced glazing standard, recommended in writing by manufacturers of glass and other glazing materials for application indicated, and with a proven record of compatibility with surfaces contacted in installation.

- B. Cleaners, Primers, and Sealers: Types recommended by sealant or gasket manufacturer.
- C. Setting Blocks:
 - 1. Type recommended in writing by sealant or glass manufacturer.
- D. Spacers:
 - 1. Neoprene blocks or continuous extrusions of hardness required by glass manufacturer to maintain glass lites in place for installation indicated.
 - 2. Type recommended in writing by sealant or glass manufacturer.
- E. Edge Blocks:
 - 1. Type recommended in writing by sealant or glass manufacturer.
- F. Cylindrical Glazing Sealant Backing: ASTM C1330, Type O (open-cell material), of size and density to control glazing sealant depth and otherwise produce optimum glazing sealant performance.

2.8 FABRICATION OF GLAZING UNITS

- A. Fabricate glazing units in sizes required to fit openings indicated for Project, with edge and face clearances, edge and surface conditions, and bite complying with written instructions of product manufacturer and referenced glazing publications, to comply with system performance requirements.
 - 1. Allow for thermal movements from ambient and surface temperature changes acting on glass framing members and glazing components.
 - a. Temperature Change: 120 deg F, ambient; 180 deg F, material surfaces.
- B. Clean-cut or flat-grind vertical edges of butt-glazed monolithic lites to produce square edges with slight chamfers at junctions of edges and faces.
- C. Grind smooth and polish exposed glass edges and corners.

PART 3 - EXECUTION

3.1 EXAMINATION

- A. Examine framing, glazing channels, and stops, with Installer present, for compliance with the following:
 - 1. Manufacturing and installation tolerances, including those for size, squareness, and offsets at corners.
 - 2. Presence and functioning of weep systems.

3. Minimum required face and edge clearances.
4. Effective sealing between joints of glass-framing members.

B. Proceed with installation only after unsatisfactory conditions have been corrected.

3.2 PREPARATION

- A. Clean glazing channels and other framing members receiving glass immediately before glazing. Remove coatings not firmly bonded to substrates.
- B. Examine glazing units to locate exterior and interior surfaces. Label or mark units as needed so that exterior and interior surfaces are readily identifiable. Do not use materials that leave visible marks in the completed Work.

3.3 GLAZING, GENERAL

- A. Comply with combined written instructions of manufacturers of glass, sealants, gaskets, and other glazing materials, unless more stringent requirements are indicated, including those in referenced glazing publications.
- B. Protect glass edges from damage during handling and installation. Remove damaged glass from Project site and legally dispose of off Project site. Damaged glass includes glass with edge damage or other imperfections that, when installed, could weaken glass, impair performance, or impair appearance.
- C. Apply primers to joint surfaces where required for adhesion of sealants, as determined by preconstruction testing.
- D. Install setting blocks in sill rabbets, sized and located to comply with referenced glazing publications, unless otherwise required by glass manufacturer. Set blocks in thin course of compatible sealant suitable for heel bead.
- E. Do not exceed edge pressures stipulated by glass manufacturers for installing glass lites.
- F. Provide spacers for glass lites where length plus width is larger than **50 inches**.
 1. Locate spacers directly opposite each other on both inside and outside faces of glass. Install correct size and spacing to preserve required face clearances, unless gaskets and glazing tapes are used that have demonstrated ability to maintain required face clearances and to comply with system performance requirements.
 2. Provide **1/8-inch-** minimum bite of spacers on glass and use thickness equal to sealant width. With glazing tape, use thickness slightly less than final compressed thickness of tape.
- G. Provide edge blocking where indicated or needed to prevent glass lites from moving sideways in glazing channel, as recommended in writing by glass manufacturer and in accordance with requirements in referenced glazing publications.

- H. Set glass lites in each series with uniform pattern, draw, bow, and similar characteristics.
- I. Set glass lites with proper orientation so that coatings face exterior or interior as specified.
- J. Where wedge-shaped gaskets are driven into one side of channel to pressurize sealant or gasket on opposite side, provide adequate anchorage so gasket cannot walk out when installation is subjected to movement.
- K. Square cut wedge-shaped gaskets at corners and install gaskets in a manner recommended by gasket manufacturer to prevent corners from pulling away; seal corner joints and butt joints with sealant recommended in writing by gasket manufacturer.

3.4 GASKET GLAZING (DRY)

- A. Cut compression gaskets to lengths recommended by gasket manufacturer to fit openings exactly, with allowance for stretch during installation.
- B. Insert soft compression gasket between glass and frame or fixed stop so it is securely in place with joints miter cut and bonded together at corners.
- C. Installation with Drive-in Wedge Gaskets: Center glass lites in openings on setting blocks, and press firmly against soft compression gasket by inserting dense compression gaskets formed and installed to lock in place against faces of removable stops. Start gasket applications at corners and work toward centers of openings. Compress gaskets to produce a weathertight seal without developing bending stresses in glass. Seal gasket joints with sealant recommended in writing by gasket manufacturer.
- D. Installation with Pressure-Glazing Stops: Center glass lites in openings on setting blocks, and press firmly against soft compression gasket. Install dense compression gaskets and pressure-glazing stops, applying pressure uniformly to compression gaskets. Compress gaskets to produce a weathertight seal without developing bending stresses in glass. Seal gasket joints with sealant recommended in writing by gasket manufacturer.
- E. Install gaskets so they protrude past face of glazing stops.

3.5 SEALANT GLAZING (WET)

- A. Install continuous spacers, or spacers combined with cylindrical sealant backing, between glass lites and glazing stops to maintain glass face clearances and to prevent sealant from extruding into glass channel and blocking weep systems until sealants cure. Secure spacers or spacers and backings in place and in position to control depth of installed sealant relative to edge clearance for optimum sealant performance.
- B. Force sealants into glazing channels to eliminate voids and to ensure complete wetting

or bond of sealant to glass and channel surfaces.

- C. Tool exposed surfaces of sealants to provide a substantial wash away from glass.

3.6 CLEANING AND PROTECTION

- A. Immediately after installation, remove nonpermanent labels and clean surfaces.
- B. Protect glass from contact with contaminating substances resulting from construction operations. Examine glass surfaces adjacent to or below exterior concrete and other masonry surfaces at frequent intervals during construction, but not less than once a month, for buildup of dirt, scum, alkaline deposits, or stains.
 - 1. If, despite such protection, contaminating substances do contact with glass, remove substances immediately as recommended in writing by glass manufacturer. Remove and replace glass that cannot be cleaned without damage to coatings.
- C. Remove and replace glass that is damaged during construction period.
- D. Wash glass on both exposed surfaces not more than four days before date scheduled for inspections that establish date of Substantial Completion. Wash glass as recommended in writing by glass manufacturer. Do not use harsh cleaning materials or methods that would damage glass.

END OF SECTION 088000

SECTION 088853 - SECURITY GLAZING

PART 1 - GENERAL

1.1 SUMMARY

- A. Section includes:
 - 1. Polycarbonate security glazing.
- B. Related Requirements:

1.2 ACTION SUBMITTALS

- A. Product Data: For each type of product.
- B. Samples for Initial Selection: Manufacturer's standard color sheets, showing full range of available colors for each type of glass tint.
- C. Security Glazing Schedule: List security glazing types and thicknesses for each size opening and location. Use same designations indicated on Drawings. Indicate coordinated dimensions of security glazing and construction that receives security glazing, including clearances and glazing channel dimensions.

1.3 INFORMATIONAL SUBMITTALS

- A. Test and Evaluation Reports:
 - 1. Product Test Reports:
 - a. For each type of security glazing, for tests performed by qualified testing agency.
 - b. For each type of glazing sealant, for tests performed by a qualified testing agency.
 - 1) Provide test reports based on testing current sealant formulations within previous 36-month period.
- B. Qualification Statements: For installers.
- C. Delegated design engineer qualifications.
- D. Sample warranties.

1.4 QUALITY ASSURANCE

A. Qualifications:

1. Installers: Authorized representative who is trained and approved by manufacturer.
2. Sealant Testing Agency: An independent testing agency qualified in accordance with ASTM C1021 to conduct the testing indicated.

1.5 FIELD CONDITIONS

A. Environmental Limitations: Do not proceed with glazing when ambient and substrate temperature conditions are outside limits permitted by glazing material manufacturers and when glazing channel substrates are wet from rain, frost, condensation, or other causes.

1. Do not install glazing sealants when ambient and substrate temperature conditions are outside limits permitted by sealant manufacturer or below **40 deg F**.

1.6 WARRANTY

A. Special Warranty, Laminated-Polycarbonate Security Glazing: Manufacturer agrees to replace laminated-polycarbonate security glazing that fails in materials or workmanship within specified warranty period.

1. Failures include, but are not limited to, the following:
 - a. Defects developed from normal use that are not attributed to maintaining and cleaning laminated-polycarbonate security glazing contrary to manufacturer's written instructions. Defects include edge separation, delamination materially obstructing vision through glazing, blemishes exceeding those allowed by referenced standard, yellowing, and loss of light transmission.
2. Warranty Period: 10 years from date of Substantial Completion.

PART 2 - PRODUCTS

2.1 PERFORMANCE REQUIREMENTS

A. General:

1. Installed security glazing will withstand security-related loads and forces without damage to the glazing beyond that allowed by referenced standards.

B. Structural Performance: Glazing will withstand the following design loads within limits

and under conditions indicated.

2.2 SECURITY GLAZING, GENERAL

- A. Glazing Publications: Comply with published recommendations of security glazing and glazing material manufacturers and organizations below unless more stringent requirements are indicated. Refer to these publications for glazing terms not otherwise defined in this Section or in referenced standards.
1. AAMA Publications: AAMA GDSG-1 and AAMA TIR-A7.
 2. NGA Publications: "Laminated Glazing Reference Manual" and "GANA Glazing Manual."
- B. Thickness of Tinted Glass: Provide same thickness for each tint color indicated throughout Project.
- C. Fire-Test-Response Characteristics of Polycarbonate Sheets: As determined by testing polycarbonate sheets identical to those used in security glazing products by a qualified testing agency acceptable to authorities having jurisdiction.
1. Self-ignition temperature of **650 deg F** or more when tested in accordance with ASTM D1929 on plastic sheets in thicknesses indicated for the Work.
 2. Smoke-Developed Index of 450 or less when tested in accordance with ASTM E84 or UL 723, or smoke density of 75 or less when tested in accordance with ASTM D2843 on plastic sheets in thicknesses indicated for the Work.
 3. Burning extent of **1 inch** or less when tested in accordance with ASTM D635 at a nominal thickness of **0.060 inch** or thickness indicated for the Work.

2.3 POLYCARBONATE SECURITY GLAZING

- A. Basis-of-Design Product: Subject to compliance with requirements, provide ForceProtect Lexgard SP1250 or BulletBlock SP 1.25 Level 3 Acrylic or Approved Equivalent by one of the following:
1. Dlubak Specialty Glass Corporation; Consolidated Glass Holdings, Inc.
 2. Global Security Glazing; Consolidated Glass Holdings, Inc.
 3. McGrory Glass, Inc
 4. OldCastle BuildingEnvelope (OBE)
 5. Palram Americas Ltd.
 6. Plaskolite
 7. Standard Bent Glass Corp
 8. Total Security Solutions
- B. Laminated-Polycarbonate Security Glazing: Two or more polycarbonate sheets bonded with clear urethane interlayer that complies with ASTM C1349, Appendix X2, and has a proven record of no tendency to bubble, discolor, or lose physical and mechanical properties after fabrication and installation. Provide laminated units that comply with requirements of ASTM C1349 for maximum allowable laminating process blemishes and haze.

2.4 MISCELLANEOUS GLAZING MATERIALS

- A. General: Provide products of material, size, and shape complying with referenced glazing standard, recommended in writing by manufacturers of security glazing and other glazing materials for application indicated, and with a proven record of compatibility with surfaces contacted in installation.
- B. Cleaners, Primers, and Sealers: Types recommended by sealant or gasket manufacturer.
- C. Setting Blocks:
 - 1. Type recommended in writing by sealant or glass manufacturer.
- D. Spacers:
 - 1. Type recommended in writing by sealant or security glazing manufacturer.
- E. Edge Blocks:
 - 1. Type recommended in writing by sealant or security glazing manufacturer.
- F. Cylindrical Glazing Sealant Backing: ASTM C1330, Type O (open-cell material), of size and density to control glazing sealant depth and otherwise produce optimum glazing sealant performance.

2.5 FABRICATION OF SECURITY GLAZING

- A. Fabricate security glazing in sizes required to fit openings indicated for Project, with edge and face clearances, edge and surface conditions, and bite complying with written instructions of product manufacturer and referenced glazing publications, to comply with system performance requirements.
- B. Grind smooth and polish exposed security glazing edges and corners.

PART 3 - EXECUTION

3.1 LAMINATED-POLYCARBONATE SECURITY GLAZING SCHEDULE

- A. Security Glazing: Laminated polycarbonate.
 - 1. Basis-of-Design Product: Force Protect; Lexgard SP1250 and Bulletblock SP 1.25 Level 3 Acrylic.
 - 2. Detention Security Grade: Grade 1 in accordance with ASTM F1915 .
 - 3. Ballistic Resistance, UL 752: Level 3 in accordance with UL 752.
 - 4. Provide abrasion resistance coatings on both sides.
 - 5. Maximum Overall Unit Thickness: 1.3 inches.
 - 6. Number of Plies: Three Four.

7. Installation: When used for ballastic protection, glazing should be installed in a UL Level 3 Bullet Resistant frame system. Holes should be covered with a UL listed device. All glazing should be installed in accordance with the guidelines set forth in the current edition of the Glass Association of North America (GANA) Glazing and Sealant Manuals. Glazing systems should incorporate a weep system to allow moisture to escape the glazing channel.

END OF SECTION 088853

SECTION 088300 - MIRRORS

PART 1 - GENERAL

1.1 SUMMARY

A. Related Requirements:

1. Section 102800 "Toilet, Bath, and Laundry Accessories" for metal-framed mirrors.

1.2 ACTION SUBMITTALS

A. Product Data: For each type of product.

1. Mirrors: Include description of materials and process used to produce each type of silvered flat glass mirror specified that indicates sources of glass, glass coating components, edge sealer, and quality-control provisions.

B. Shop Drawings: Include mirror elevations, edge details, mirror hardware, and attachment details.

1.3 INFORMATIONAL SUBMITTALS

A. Product Certificates: For each type of mirror and mirror mastic.

B. Preconstruction Test Reports: From mirror manufacturer indicating that mirror mastic was tested for compatibility and adhesion with mirror backing and substrates on which mirrors are installed.

C. Qualification Statements: For Installer.

1.4 CLOSEOUT SUBMITTALS

A. Maintenance Data: For mirrors to include in maintenance manuals.

1.5 QUALITY ASSURANCE

A. Installer Qualifications: A qualified Installer, who employs glass installers for this Project who are certified under the National Glass Association's Certified Glass Installer Program.

1.6 FIELD CONDITIONS

- A. Environmental Limitations: Do not install mirrors until ambient temperature and humidity conditions are maintained at levels indicated for final occupancy.

1.7 WARRANTY

- A. Special Warranty: Manufacturer agrees to replace mirrors that deteriorate within specified warranty period. Deterioration of mirrors is defined as defects developed from normal use that are not attributed to mirror breakage or to maintaining and cleaning mirrors contrary to manufacturer's written instructions. Defects include discoloration, black spots, and clouding of the silver film.

1. Warranty Period: Five years from date of Substantial Completion.

PART 2 - PRODUCTS

2.1 MIRROR HARDWARE

- A. Aluminum J-Channels: Aluminum extrusions with a return deep enough to produce a glazing channel to accommodate mirrors of thickness indicated and in lengths required to cover edges of mirrors in a single piece.
 1. Aluminum J-Channel Bottom and Side Trim: J-channels formed with front leg and back leg not less than **3/8 and 7/8 inch** in height, respectively, and a thickness of not less than **0.04 inch**.
 - a. Manufacturers: Subject to compliance with requirements, available manufacturers offering products that may be incorporated into the Work include, but are not limited to, the following:
 - 1) Andscot Company, Inc.
 - 2) C.R. Laurence Co., Inc.; CRH Americas, Inc.
 - 3) Stylmark, Inc.
 2. Finish: Clear bright anodized.
- B. Aluminum J-Channels and Cleat: Aluminum extrusions with a return deep enough to produce a glazing channel to accommodate mirrors of thickness indicated and in lengths required to cover edges of mirrors in a single piece.
 1. Finish: Clear bright anodized.
- C. Mirror Bottom Clips: Provide Aluminum bottom clips.
- D. Mirror Top Clips: As indicated Provide Aluminum top clips.
- E. Fasteners: Fabricated of same basic metal and alloy as fastened metal and matching it

in finished color and texture where fasteners are exposed.

- F. Anchors and Inserts: Provide devices as required for mirror hardware installation. Provide toothed or lead-shield, expansion-bolt devices for drilled-in-place anchors. Provide galvanized anchors and inserts for applications on inside face of exterior walls and where indicated.

2.2 FABRICATION

- A. Shop fabricate mirrors to greatest extent possible.
- B. Fabricate cutouts for notches and holes in mirrors without marring visible surfaces. Locate and size cutouts, so they fit closely around penetrations in mirrors.
- C. Mirror Edge Treatment: Flat polished.
 - 1. Seal edges of mirrors with edge sealer after edge treatment to prevent chemical or atmospheric penetration of glass coating.
 - 2. Require mirror manufacturer to perform edge treatment and sealing in factory immediately after cutting to final sizes.
- D. Film-Backed Safety Mirrors: Apply film backing with adhesive coating over mirror backing paint, as recommended in writing by film-backing manufacturer, to produce a surface free of bubbles, blisters, and other imperfections.

PART 3 - EXECUTION

3.1 INSTALLATION OF MIRRORS

- A. General: Install mirrors to comply with mirror manufacturer's written instructions and with referenced National Glass Association (NGA) publications. Mount mirrors accurately in place in a manner that avoids distorting reflected images.
 - 1. NGA Publications: "Laminated Glazing Reference Manual," "Glazing Manual" and "Installation Techniques Designed to Prolong the Life of Flat Glass Mirrors."
- B. Provide a minimum airspace of **1/8 inch** between back of mirrors and mounting surface for air circulation between back of mirrors and face of mounting surface.
- C. Install mirrors with mastic and mirror hardware. Attach mirror hardware securely to mounting surfaces with mechanical fasteners installed with anchors or inserts as applicable. Install fasteners so heads do not impose point loads on backs of mirrors.
 - 1. Aluminum J-Channels: Provide setting blocks **1/8 inch** thick by **4 inches** long at quarter points. To prevent trapping water, provide, between setting blocks, two slotted weeps not less than **1/4 inch** wide by **3/8 inch** long at bottom channel.
 - 2. Aluminum J-Channels and Cleat: Fasten J-channel directly to wall and attach top trim to continuous cleat fastened directly to wall.

3. Mirror Clips: Place a felt or plastic pad between mirror and each clip to prevent spalling of mirror edges. Locate clips so they are symmetrically placed and evenly spaced.
4. Install mastic as follows:
 - a. Apply barrier coat to mirror backing where approved in writing by manufacturers of mirrors and backing material.
 - b. Apply mastic to comply with mastic manufacturer's written instructions for coverage and to allow air circulation between back of mirrors and face of mounting surface.
 - c. After mastic is applied, align mirrors and press into place while maintaining a minimum airspace of **1/8 inch** between back of mirrors and mounting surface.

END OF SECTION 088300

SECTION 088853 - SECURITY GLAZING

PART 1 - GENERAL

1.1 SUMMARY

- A. Section includes:
 - 1. Polycarbonate security glazing.
- B. Related Requirements:

1.2 ACTION SUBMITTALS

- A. Product Data: For each type of product.
- B. Samples for Initial Selection: Manufacturer's standard color sheets, showing full range of available colors for each type of glass tint.
- C. Security Glazing Schedule: List security glazing types and thicknesses for each size opening and location. Use same designations indicated on Drawings. Indicate coordinated dimensions of security glazing and construction that receives security glazing, including clearances and glazing channel dimensions.

1.3 INFORMATIONAL SUBMITTALS

- A. Test and Evaluation Reports:
 - 1. Product Test Reports:
 - a. For each type of security glazing, for tests performed by qualified testing agency.
 - b. For each type of glazing sealant, for tests performed by a qualified testing agency.
 - 1) Provide test reports based on testing current sealant formulations within previous 36-month period.
- B. Qualification Statements: For installers.
- C. Delegated design engineer qualifications.
- D. Sample warranties.

1.4 QUALITY ASSURANCE

A. Qualifications:

1. Installers: Authorized representative who is trained and approved by manufacturer.
2. Sealant Testing Agency: An independent testing agency qualified in accordance with ASTM C1021 to conduct the testing indicated.

1.5 FIELD CONDITIONS

A. Environmental Limitations: Do not proceed with glazing when ambient and substrate temperature conditions are outside limits permitted by glazing material manufacturers and when glazing channel substrates are wet from rain, frost, condensation, or other causes.

1. Do not install glazing sealants when ambient and substrate temperature conditions are outside limits permitted by sealant manufacturer or below **40 deg F**.

1.6 WARRANTY

A. Special Warranty, Laminated-Polycarbonate Security Glazing: Manufacturer agrees to replace laminated-polycarbonate security glazing that fails in materials or workmanship within specified warranty period.

1. Failures include, but are not limited to, the following:
 - a. Defects developed from normal use that are not attributed to maintaining and cleaning laminated-polycarbonate security glazing contrary to manufacturer's written instructions. Defects include edge separation, delamination materially obstructing vision through glazing, blemishes exceeding those allowed by referenced standard, yellowing, and loss of light transmission.
2. Warranty Period: 10 years from date of Substantial Completion.

PART 2 - PRODUCTS

2.1 PERFORMANCE REQUIREMENTS

A. General:

1. Installed security glazing will withstand security-related loads and forces without damage to the glazing beyond that allowed by referenced standards.

B. Structural Performance: Glazing will withstand the following design loads within limits

and under conditions indicated.

2.2 SECURITY GLAZING, GENERAL

- A. Glazing Publications: Comply with published recommendations of security glazing and glazing material manufacturers and organizations below unless more stringent requirements are indicated. Refer to these publications for glazing terms not otherwise defined in this Section or in referenced standards.
1. AAMA Publications: AAMA GDSG-1 and AAMA TIR-A7.
 2. NGA Publications: "Laminated Glazing Reference Manual" and "GANA Glazing Manual."
- B. Thickness of Tinted Glass: Provide same thickness for each tint color indicated throughout Project.
- C. Fire-Test-Response Characteristics of Polycarbonate Sheets: As determined by testing polycarbonate sheets identical to those used in security glazing products by a qualified testing agency acceptable to authorities having jurisdiction.
1. Self-ignition temperature of **650 deg F** or more when tested in accordance with ASTM D1929 on plastic sheets in thicknesses indicated for the Work.
 2. Smoke-Developed Index of 450 or less when tested in accordance with ASTM E84 or UL 723, or smoke density of 75 or less when tested in accordance with ASTM D2843 on plastic sheets in thicknesses indicated for the Work.
 3. Burning extent of **1 inch** or less when tested in accordance with ASTM D635 at a nominal thickness of **0.060 inch** or thickness indicated for the Work.

2.3 POLYCARBONATE SECURITY GLAZING

- A. Basis-of-Design Product: Subject to compliance with requirements, provide ForceProtect Lexgard SP1250 or BulletBlock SP 1.25 Level 3 Acrylic or Approved Equivalent by one of the following:
1. Dlubak Specialty Glass Corporation; Consolidated Glass Holdings, Inc.
 2. Global Security Glazing; Consolidated Glass Holdings, Inc.
 3. McGrory Glass, Inc
 4. OldCastle BuildingEnvelope (OBE)
 5. Palram Americas Ltd.
 6. Plaskolite
 7. Standard Bent Glass Corp
 8. Total Security Solutions
- B. Laminated-Polycarbonate Security Glazing: Two or more polycarbonate sheets bonded with clear urethane interlayer that complies with ASTM C1349, Appendix X2, and has a proven record of no tendency to bubble, discolor, or lose physical and mechanical properties after fabrication and installation. Provide laminated units that comply with requirements of ASTM C1349 for maximum allowable laminating process blemishes and haze.

2.4 MISCELLANEOUS GLAZING MATERIALS

- A. General: Provide products of material, size, and shape complying with referenced glazing standard, recommended in writing by manufacturers of security glazing and other glazing materials for application indicated, and with a proven record of compatibility with surfaces contacted in installation.
- B. Cleaners, Primers, and Sealers: Types recommended by sealant or gasket manufacturer.
- C. Setting Blocks:
 - 1. Type recommended in writing by sealant or glass manufacturer.
- D. Spacers:
 - 1. Type recommended in writing by sealant or security glazing manufacturer.
- E. Edge Blocks:
 - 1. Type recommended in writing by sealant or security glazing manufacturer.
- F. Cylindrical Glazing Sealant Backing: ASTM C1330, Type O (open-cell material), of size and density to control glazing sealant depth and otherwise produce optimum glazing sealant performance.

2.5 FABRICATION OF SECURITY GLAZING

- A. Fabricate security glazing in sizes required to fit openings indicated for Project, with edge and face clearances, edge and surface conditions, and bite complying with written instructions of product manufacturer and referenced glazing publications, to comply with system performance requirements.
- B. Grind smooth and polish exposed security glazing edges and corners.

PART 3 - EXECUTION

3.1 LAMINATED-POLYCARBONATE SECURITY GLAZING SCHEDULE

- A. Security Glazing: Laminated polycarbonate.
 - 1. Basis-of-Design Product: Force Protect; Lexgard SP1250 and Bulletblock SP 1.25 Level 3 Acrylic.
 - 2. Detention Security Grade: Grade 1 in accordance with ASTM F1915 .
 - 3. Ballistic Resistance, UL 752: Level 3 in accordance with UL 752.
 - 4. Provide abrasion resistance coatings on both sides.
 - 5. Maximum Overall Unit Thickness: 1.3 inches.
 - 6. Number of Plies: Three Four.

7. Installation: When used for ballastic protection, glazing should be installed in a UL Level 3 Bullet Resistant frame system. Holes should be covered with a UL listed device. All glazing should be installed in accordance with the guidelines set forth in the current edition of the Glass Association of North America (GANA) Glazing and Sealant Manuals. Glazing systems should incorporate a weep system to allow moisture to escape the glazing channel.

END OF SECTION 088853

SECTION 092116.23 - GYPSUM BOARD SHAFT WALL ASSEMBLIES

PART 1 - GENERAL

1.1 SUMMARY

- A. Section Includes:
 - 1. Gypsum board shaft wall assemblies.

1.2 ACTION SUBMITTALS

- A. Product Data: For each component of gypsum board shaft wall assemblies.
- B. Sustainable Design Submittals:

1.3 INFORMATIONAL SUBMITTALS

- A. Evaluation Reports: From an agency acceptable to authorities having jurisdiction ICC-ES showing compliance with Project requirements, for the following:
 - 1. Studs and track.
 - 2. Equivalent corrosion-resistant coating on steel framing.
 - 3. Firestop track.
 - 4. Post-installed anchors.

1.4 DELIVERY, STORAGE, AND HANDLING

- A. Store materials inside under cover and keep them dry and protected against weather, condensation, direct sunlight, construction traffic, and other potential causes of damage.
- B. Stack shaftliner and face panels flat and support them on risers on a flat platform to prevent sagging.
- C. Protect steel framing from corrosion, deformation, and other damage during delivery, storage, and handling in accordance with AISI S202.

1.5 FIELD CONDITIONS

- A. Environmental Limitations: Comply with gypsum-shaftliner-board manufacturer's written instructions.
- B. Do not install finish panels until installation areas are enclosed and conditioned.

- C. Do not install shaftliner and face panels that are wet, moisture damaged, or mold damaged.
 - 1. Indications that panels are wet or moisture damaged include, but are not limited to, discoloration, sagging, and irregular shape.
 - 2. Indications that panels are mold damaged include, but are not limited to, fuzzy or splotchy surface contamination and discoloration.

PART 2 - PRODUCTS

2.1 PERFORMANCE REQUIREMENTS

- A. Fire-Resistance-Rated Assemblies: Provide materials and construction identical to rated assembly indicated on Drawings tested in accordance with ASTM E119 by an independent testing agency.
- B. STC-Rated Assemblies: Provide materials and construction identical to rated assembly indicated on Drawings tested in accordance with ASTM E90 and classified in accordance with ASTM E413 by a testing and inspecting agency.

2.2 GYPSUM BOARD SHAFT WALL ASSEMBLIES

- A. Fire-Resistance Rating: As indicated on Drawings.
- B. Minimum STC Rating: As indicated on Drawings.
- C. Gypsum Shaftliner Board:
 - 1. Type X: ASTM C1396/C1396M; manufacturer's proprietary fire-resistive liner panels with paper faces, **1 inch** thick, with double beveled long edges.
 - a. Manufacturers: Subject to compliance with requirements, available manufacturers offering products that may be incorporated into the Work include, but are not limited to, the following:
 - 1) American Gypsum
 - 2) Georgia-Pacific Gypsum LLC
 - 3) PABCO Gypsum
- D. Steel Framing, General: Complying with applicable requirements in AISI S220 and complying with requirements for fire-resistance-rated assemblies indicated on Drawings.
 - 1. Manufacturers: Subject to compliance with requirements, available manufacturers offering products that may be incorporated into the Work include, but are not limited to, the following:
 - a. CEMCO; California Expanded Metal Products Co.

- b. ClarkDietrich
 - c. Marino\WARE
 - d. SCAFCO Steel Stud Company; Stone Group of Companies
 - e. Steel Construction Systems; Stone Group of Companies
 - f. The Mill Steel Co
2. Protective Coating: ASTM A653/A653M, **G40** or coating with demonstrated equivalent corrosion resistance. Galvannealed products are unacceptable.
 - a. Equivalent Corrosion Resistance: Evaluation report acceptable to authorities having jurisdiction demonstrates corrosion resistance equivalent to specified protective coating.
- E. Studs: Profiles required for fire-resistance-rated assembly indicated on Drawings for repetitive, corner, and end members as follows:
1. Depth: As indicated on Drawings.
 2. Minimum Base-Steel Thickness: **0.0179 inch 0.0219 inch 0.0329 inch 0.0341 inch 0.0380 inch 0.0428 inch.**
- F. Track: J-profile track required for fire-resistance-rated assembly indicated on Drawings with minimum long-leg length of **2 inches** and matching studs in depth.
1. Minimum Base-Steel Thickness: **0.0219 inch.**
- G. Firestop Track: Deep top track manufactured to allow shaft wall heads to expand and contract with movement of the structure while maintaining continuity of fire-resistance-rated assembly indicated on Drawings; in base-steel thickness not less than that of studs and in width required to comply with requirements of fire-rated assembly.
1. Manufacturers: Subject to compliance with requirements, available manufacturers offering products that may be incorporated into the Work include, but are not limited to, the following:
 - a. ClarkDietrich
 - b. Fire Trak Corp
- H. Finish Panels: As indicated on Drawings.
- I. Sound Attenuation Blankets: As specified in Section 092900 "Gypsum Board."
- 2.3 ACCESSORIES
- A. Provide accessories that comply with shaft wall manufacturer's written instructions.
 - B. Trim Accessories: Cornerbead, edge trim, and control joints of material and shapes as specified in Section 092900 "Gypsum Board" that comply with shaft wall assembly manufacturer's written instructions for application indicated on Drawings.
 - C. Steel Drill Screws: ASTM C1002 unless otherwise indicated on Drawings.

- D. Track Fasteners: Power-driven fasteners of size and material required to withstand loading conditions imposed on shaft wall assemblies without exceeding allowable design stress of track, fasteners, or structural substrates in which anchors are embedded.
 - 1. Expansion Anchors: Fastener systems with an evaluation report, acceptable to authorities having jurisdiction, based on ICC-ES AC01 or AC193 as appropriate for the substrate.
- E. Reinforcing: Steel reinforcing strips of corrosion-resistant steel complying with steel framing requirements and in **0.0329-inch** minimum base-steel thickness.
- F. Acoustical Sealant: As specified in Section 079219 "Acoustical Joint Sealants."
- G. Gypsum Board Cants:
 - 1. Gypsum Board Panels: As specified in Section 092900 "Gypsum Board," Type X, **1/2- or 5/8-inch** panels.
 - 2. Adhesive: Laminating adhesive as specified in Section 092900 "Gypsum Board."
 - 3. Non-Structural Steel Framing: As specified in Section 092216 "Non-Structural Metal Framing."

PART 3 - EXECUTION

3.1 EXAMINATION

- A. Examine substrates and conditions, with Installer present, for compliance with requirements for installation tolerances and other conditions affecting performance of the Work.
- B. Examine shaftliner and face panels before installation. Reject panels that are wet, moisture damaged, or mold damaged.
- C. Proceed with installation only after unsatisfactory conditions have been corrected.

3.2 PREPARATION

- A. Coordination with Sprayed Fire-Resistive Materials:
 - 1. Before sprayed fire-resistive materials are applied, attach offset anchor plates or top track to surfaces indicated to receive sprayed fire-resistive materials unless otherwise indicated on Drawings. Where offset anchor plates are required, provide continuous plates fastened to building structure as required by fire-resistance-rated assembly but not more than **24 inches** o.c.
 - 2. After sprayed fire-resistive materials are applied, remove only to extent necessary for installation of shaft wall assemblies and without reducing the fire-resistive material thickness below that which is required to obtain fire-resistance rating indicated on Drawings. Protect remaining fire-resistive materials from

damage.

3. Patch or replace sprayed fire-resistive materials removed or damaged during installation of shaft wall assemblies to comply with requirements specified in Section 078100 "Applied Fire Protection."

3.3 INSTALLATION OF GYPSUM BOARD SHAFT WALL ASSEMBLIES

- A. General: Install shaft wall assemblies to comply with requirements of fire-resistance-rated assemblies indicated on Drawings and manufacturer's written installation instructions.
- B. Install supplementary framing in shaft wall assemblies around openings and as required for blocking, bracing, and support of gravity and pullout loads of fixtures, equipment, services, heavy trim, furnishings, wall-mounted door stops, and similar items that cannot be supported directly by shaft wall assembly framing.
 1. Reinforcing: Provide where items attach directly to shaft wall assembly as indicated on Drawings; accurately position and secure behind at least one layer of face panel.
- C. Penetrations: At penetrations in shaft wall assemblies, maintain fire-resistance rating of shaft wall assembly by installing supplementary steel framing around perimeter of penetration and fire protection behind boxes containing wiring devices, elevator call buttons and floor indicators, and similar items.
- D. Isolate perimeter of gypsum panels from building structure to prevent cracking of panels while maintaining continuity of fire-rated construction.
- E. Firestop Track: Where indicated on Drawings, install to maintain continuity of fire-resistance-rated assembly.
- F. Control Joints: Install control joints in accordance with ASTM C840 and in specific locations approved by Architect while maintaining fire-resistance rating of shaft wall assemblies.
- G. Sound-Rated Shaft Wall Assemblies: Seal with acoustical sealant at perimeter of each assembly where it abuts other work and at joints and penetrations within each assembly.
- H. Gypsum Board Cants: At projections into shaft exceeding **4 inches**, install gypsum board cants covering tops of projections.
 1. Slope cant panels at least 75 degrees from horizontal. Set base edge of panels in adhesive and secure top edges to shaft walls at **24 inches** o.c. with screws fastened to shaft wall framing.
 2. Where non-structural steel framing is required to support gypsum board cants, install framing at **24 inches** o.c. and extend studs from the projection to shaft wall framing.
- I. Installation Tolerance: Install each framing member so fastening surfaces vary not

more than **1/8 inch** from the plane formed by faces of adjacent framing.

3.4 PROTECTION

- A. Protect installed products from damage from weather, condensation, direct sunlight, construction, and other causes during remainder of the construction period.
- B. Remove and replace shaftliner and face panels that are wet, moisture damaged, or mold damaged.
 - 1. Indications that panels are wet or moisture damaged include, but are not limited to, discoloration, sagging, and irregular shape.
 - 2. Indications that panels are mold damaged include, but are not limited to, fuzzy or splotchy surface contamination and discoloration.

END OF SECTION 092116.23

SECTION 092216 - NON-STRUCTURAL METAL FRAMING

PART 1 - GENERAL

1.1 SUMMARY

A. Section Includes:

1. Nonstructural steel framing.
2. Grid suspension systems.

B. Related Requirements:

1. Section 054000 "Cold-Formed Metal Framing" for exterior and interior loadbearing, structural framing.

1.2 ACTION SUBMITTALS

A. Product Data: For each type of product.

B. Shop Drawings:

1. Include layout, spacings, sizes, thicknesses, and types of nonstructural steel framing and fastening and anchorage details.
2. Indicate reinforcing channels, opening framing, supplemental framing, strapping, bracing, bridging, splices, accessories, and attachments to adjoining work.

1.3 INFORMATIONAL SUBMITTALS

A. Product Certificates: For code-compliance certification of studs and track.

B. Evaluation Reports: From an agency acceptable to authorities having jurisdiction showing compliance with Project requirements, for the following:

1. Studs and track.
2. High-strength steel studs and track.
3. Equivalent corrosion-resistant coating on steel framing.
4. Firestop track.
5. Post-installed anchors.
6. Power-actuated fasteners.

1.4 QUALITY ASSURANCE

A. Code-Compliance Certification of Studs and Track: Provide documentation that framing members are certified in accordance with product-certification program of the Steel

Framing Industry Association the Steel Stud Manufacturers Association or the Supreme Steel Framing System Association.

1.5 DELIVERY, STORAGE, AND HANDLING

- A. Deliver materials in manufacturer's original, unopened, undamaged containers with identification labels intact.
- B. Protect materials from corrosion, deformation, and other damage during delivery, storage, and handling in accordance with AISI S202.

PART 2 - PRODUCTS

2.1 PERFORMANCE REQUIREMENTS

- A. Fire-Test-Response Characteristics: Where indicated on Drawings, provide assemblies incorporating nonstructural steel framing identical to those of assemblies tested for fire resistance in accordance with ASTM E119 by an independent testing agency.
- B. STC-Rated Assemblies: Where indicated on Drawings, provide assemblies incorporating nonstructural framing identical to those of assemblies tested in accordance with ASTM E90 and classified in accordance with ASTM E413 by an independent testing agency.
- C. Horizontal Deflection: For composite non-composite wall assemblies, limited to 1/360 of the wall height based on the following horizontal loading:
 - 1. Horizontal Loading: 5 lbf/sq. ft..

2.2 NONSTRUCTURAL STEEL FRAMING

- A. Framing Members, General: Comply with requirements in AISI S220 for conditions indicated on Drawings.
 - 1. Protective Coating: ASTM A653/A653M, G40 or coating with demonstrated equivalent corrosion resistance. Galvannealed products are unacceptable.
 - a. Equivalent Corrosion-Resistant Coating: Evaluation report acceptable to authorities having jurisdiction demonstrates corrosion resistance equivalent to specified protective coating.
- B. Studs and Track: Conventional members, roll-formed into standard shapes without surface deformations to stiffen framing members.
 - 1. Manufacturers: Subject to compliance with requirements, available manufacturers offering products that may be incorporated into the Work include, but are not limited to, the following:

- a. CEMCO; California Expanded Metal Products Co.
 - b. ClarkDietrich
 - c. CRACO Mfg., Inc.
 - d. Jaimes Industries, Inc.
 - e. Marino\WARE
 - f. MBA Building Supplies
 - g. MBA Metal Framing
 - h. MRI Steel Framing, LLC
 - i. SCAFCO Steel Stud Company; Stone Group of Companies
 - j. Steel Construction Systems; Stone Group of Companies
 - k. Steel Network, Inc. (The)
 - l. TELLING Industries
 - m. UMS Metal Building Systems USA LLC
 - n. US Frame Factory
2. Minimum Base-Steel Thickness: As required by performance requirements for horizontal deflection.
 3. Minimum Yield Strength: **33 ksi**.
 4. Depth: As indicated on Drawings.
- C. High-Strength Steel Studs and Track: Roll-formed into proprietary shapes incorporating ribs, embossment, knurling, or dimensional changes to stiffen framing members.
1. Manufacturers: Subject to compliance with requirements, available manufacturers offering products that may be incorporated into the Work include, but are not limited to, the following:
 - a. CEMCO; California Expanded Metal Products Co.
 - b. ClarkDietrich
 - c. CRACO Mfg., Inc.
 - d. Marino\WARE
 - e. MBA Building Supplies
 - f. MBA Metal Framing
 - g. MRI Steel Framing, LLC
 - h. SCAFCO Steel Stud Company; Stone Group of Companies
 - i. Steel Construction Systems; Stone Group of Companies
 - j. TELLING Industries
 - k. The Mill Steel Co
 - l. US Frame Factory
 2. Minimum Base-Steel Thickness and Yield Strength: As required by horizontal deflection performance requirements.
 3. Depth: As indicated on Drawings.
- D. Slip-Type Head Joints: Where indicated on Drawings, provide one of the following:
1. Double-Track System: Top outer track sized to friction-fit over inner track and inner track with **2-inch-** deep flanges in base-steel thickness not less than that of studs and fastened to studs.

- a. Manufacturers: Subject to compliance with requirements, available manufacturers offering products that may be incorporated into the Work include, but are not limited to, the following:
 - 1) ClarkDietrich
 - 2) SCAFCO Steel Stud Company; Stone Group of Companies
 - 3) Steel Construction Systems; Stone Group of Companies
 - 4) US Frame Factory

- E. Firestop Track: Top track manufactured to allow partition heads to expand and contract with movement of structure above while maintaining continuity of fire-resistance-rated assembly indicated on Drawings; in base-steel thickness not less than that of studs and in width to accommodate depth of studs.
 1. Manufacturers: Subject to compliance with requirements, available manufacturers offering products that may be incorporated into the Work include, but are not limited to, the following:
 - a. CEMCO; California Expanded Metal Products Co.
 - b. ClarkDietrich
 - c. Fire Trak Corp
 - d. Marino\WARE
 - e. Metal-Lite
 - f. SCAFCO Steel Stud Company; Stone Group of Companies
 - g. Steel Construction Systems; Stone Group of Companies
 - h. Steel Network, Inc. (The)
 - i. TELLING Industries

2.3 GRID SUSPENSION SYSTEMS

- A. Grid Suspension Systems for Gypsum Board Ceilings: ASTM C645, direct-hung system composed of main beams and cross-furring members that interlock.
 1. Manufacturers: Subject to compliance with requirements, available manufacturers offering products that may be incorporated into the Work include, but are not limited to, the following:
 - a. Armstrong World Industries
 - b. CertainTeed; SAINT-GOBAIN
 - c. Rockfon; ROCKWOOL International
 - d. USG Corporation

2.4 AUXILIARY MATERIALS

- A. General: Provide auxiliary materials that comply with referenced installation standards.
 1. Fasteners for Steel Framing: Of type, material, size, corrosion resistance, holding power, and other properties required to fasten steel members to substrates.

- B. Tie Wire: ASTM A641/A641M, Class 1 zinc coating, soft temper.
 - 1. Adjustable Wall-Furring Brackets for Tie Wire: Use minimum double strand of **0.0625-inch-** diameter wire, or triple strand of **0.0475-inch-** diameter wire to attach furring channels.
 - 2. Suspended-Ceiling Systems:
 - a. Splicing Carrying Channels and Furring Members: Use double loops of minimum **0.0625-inch-** diameter wire.
 - b. Saddle Tying Main Runners and Cross Furring: Use minimum **0.0625-inch-** diameter wire, or double strand of **0.0475-inch-** diameter wire.
- C. Post-Installed Anchors: Fastener systems with an evaluation report, acceptable to authorities having jurisdiction, based on ICC-ES AC01 AC193 AC58 or AC308 as appropriate for the substrate.
 - 1. Securing Hangers:
 - a. Type: Post-installed screw, drop-in anchor, or adhesive anchor..
 - b. Material for Interior Locations: Carbon-steel components zinc-plated to comply with ASTM B633 or ASTM F1941/F1941M, Class Fe/Zn 5, unless otherwise indicated on Drawings.
 - c. Stainless Steel Material for Exterior or Interior Locations: Alloy Group **1** stainless steel bolts, ASTM F593, and nuts, ASTM F594.
- D. Wire Hangers: ASTM A641/A641M, Class 1 zinc coating, soft temper, **0.162 inch** in diameter.
- E. Flat Hangers: ASTM A653/A653M **G40** hot-dip galvanized steel sheet, **1 by 3/16 inch** by length indicated on Drawings.
- F. Isolation Strip at Exterior Walls: Provide one of the following:
 - 1. Foam Gasket: Adhesive-backed, closed-cell vinyl foam strips that allow fastener penetration without foam displacement, **1/8 inch** thick, in width to suit steel stud size.

PART 3 - EXECUTION

3.1 EXAMINATION

- A. Examine areas, substrates, and conditions, with Installer present, for compliance with requirements and other conditions affecting performance of the Work.
- B. Proceed with installation only after unsatisfactory conditions have been corrected.

3.2 PREPARATION

- A. Suspended Assemblies: Coordinate installation of suspension systems with installation of overhead structure to ensure that inserts and other provisions for anchorages to building structure have been installed to receive hangers at spacing required to support the Work and that hangers will develop their full strength.
 - 1. Furnish concrete inserts and other devices required to other trades for installation in advance of time needed for coordination and construction.
- B. Coordination with Sprayed Fire-Resistive Materials:
 - 1. Before sprayed fire-resistive materials are applied, attach offset anchor plates or ceiling track to surfaces indicated on Drawings to receive sprayed fire-resistive materials. Where offset anchor plates are required, provide continuous plates fastened to building structure not more than **24 inches** o.c.
 - 2. After sprayed fire-resistive materials are applied, remove them only to extent necessary for installation of nonstructural steel framing. Do not reduce thickness of fire-resistive materials below that required for fire-resistance ratings indicated on Drawings. Protect adjacent fire-resistive materials from damage.

3.3 INSTALLATION OF NONSTRUCTURAL METAL FRAMING, GENERAL

- A. Installation Standard: ASTM C754.
 - 1. Gypsum Plaster Assemblies: Also comply with requirements in ASTM C841 that apply to framing installation.
 - 2. Portland Cement Plaster Assemblies: Also comply with requirements in ASTM C1063 that apply to framing installation.
 - 3. Gypsum Veneer Plaster Assemblies: Also comply with requirements in ASTM C844 that apply to framing installation.
 - 4. Gypsum Board Assemblies: Also comply with requirements in ASTM C840 that apply to framing installation.
- B. Install framing and accessories plumb, square, and true to line, with connections securely fastened.
- C. Install supplementary framing, and blocking to support fixtures, equipment services, heavy trim, grab bars, toilet accessories, furnishings, or similar construction.
- D. Install bracing at terminations in assemblies.
- E. Do not bridge building control and expansion joints with framing members. Frame both sides of joints independently.

3.4 INSTALLATION OF NONSTRUCTURAL STEEL FRAMING

- A. Install framing system components at spacings indicated on Drawings, but not greater than spacings required by referenced installation standards for assembly types.

- B. Where studs are installed directly against exterior masonry walls or dissimilar metals at exterior walls, install isolation strip between studs and exterior wall.
- C. Install studs so flanges within framing system point in same direction.
- D. Install track at floors and overhead supports. Extend framing full height to structural supports or substrates above suspended ceilings except where partitions are indicated on Drawings to terminate at suspended ceilings. Continue framing around ducts that penetrate partitions above ceiling.
 - 1. Slip-Type Head Joints: Where framing extends to overhead structural supports, install to produce joints at tops of framing systems that prevent axial loading of finished assemblies.
 - 2. Door Openings: Screw vertical studs at jambs to jamb anchor clips on door frames; install track section (for cripple studs) at head and secure to jamb studs.
 - a. Install two studs at each jamb unless otherwise indicated on Drawings.
 - b. Install cripple studs at head adjacent to each jamb stud, with a minimum **1/2-inch** clearance from jamb stud to allow for installation of control joint in finished assembly.
 - c. Extend jamb studs through suspended ceilings and attach to underside of overhead structure unless otherwise indicated on Drawings.
 - 3. Other Framed Openings: Frame openings other than door openings the same as required for door openings unless otherwise indicated on Drawings. Install framing below sills of openings to match framing required above door heads.
 - 4. Fire-Resistance-Rated Partitions: Install framing to comply with fire-resistance-rated assembly indicated on Drawings and support closures to make partitions continuous from floor to underside of solid structure.
 - a. Firestop Track: Install to maintain continuity of fire-resistance-rated assembly indicated on Drawings.
 - 5. STC-Rated Partitions: Install framing to comply with STC-rated assembly indicated on Drawings.
 - 6. Curved Partitions:
 - a. Bend track to uniform curve and locate straight lengths so they are tangent to arcs.
 - b. Begin and end each arc with a stud, and space intermediate studs equally along arcs. On straight lengths of at least two studs at ends of arcs, place studs **6 inches** o.c.
- E. Direct Furring:
 - 1. Screw to wood framing.
 - 2. Attach to concrete or masonry with stub nails, screws designed for masonry attachment, or powder-driven fasteners spaced **24 inches** o.c.
- F. Z-Shaped Furring Members:

1. Except at exterior corners, securely attach narrow flanges of furring members to wall with concrete stub nails, screws designed for masonry attachment, or powder-driven fasteners spaced **24 inches** o.c.
 2. At exterior corners, attach wide flange of furring members to wall with short flange extending beyond corner; on adjacent wall surface, screw-attach short flange of furring channel to web of attached channel. At interior corners, space second member no more than **12 inches** from corner and cut insulation to fit.
- G. Suspended Assemblies: Isolate suspension assemblies from building structure where they abut or are penetrated by building structure to prevent transfer of loading imposed by structural movement.
1. Hangers: Install hangers plumb and free from contact with insulation or other objects within ceiling plenum that are not part of supporting structural or suspension system spaced as required to meet performance requirements.
 - a. Splay hangers only where required to miss obstructions and offset resulting horizontal forces by bracing, countersplaying, or other equally effective means.
 - b. Where width of ducts and other construction within ceiling plenum produces hanger spacings that interfere with locations of hangers required to support standard suspension system members, install supplemental suspension members and hangers in the form of trapezes or equivalent devices.
 - 1) Size supplemental suspension members and hangers to support ceiling loads within performance limits established by referenced installation standards.
 - c. Wire Hangers: Secure by looping and wire tying, either directly to structures or to inserts, eye screws, or other devices and fasteners that are secure and appropriate for substrate, and in a manner that will not cause hangers to deteriorate or otherwise fail.
 - d. Flat Hangers: Secure to structure, including intermediate framing members, by attaching to inserts, eye screws, or other devices and fasteners that are secure and appropriate for structure and hanger, and in a manner that will not cause hangers to deteriorate or otherwise fail.
 - e. Do not attach hangers to steel roof deck.
 - f. Do not attach hangers to permanent metal forms. Furnish cast-in-place hanger inserts that extend through forms.
 - g. Do not attach hangers to rolled-in hanger tabs of composite steel floor deck.
 - h. Do not connect or suspend framing from ducts, pipes, or conduit.
 2. Carrying Channels (Main Runners): U-channels spaced as indicated on Drawings.
 3. Furring Channels (Furring Members): Steel studs and track.
 - a. Spacing: As indicated on Drawings.
 - b. Fire-Resistance-Rated Assemblies: Wire tie furring channels to supports.

H. Installation Tolerances for Nonstructural Steel Framing:

1. Framing Members: Install each framing member so fastening surfaces vary not more than **1/8 inch** from the plane formed by faces of adjacent framing.
2. Suspended Assemblies: Install suspension systems that are level to within **1/8 inch in 12 ft.** measured lengthwise on each member that will receive finishes and transversely between parallel members that will receive finishes.

3.5 INSTALLATION OF GRID SUSPENSION SYSTEMS

- A. Grid Suspension Systems: Install in accordance with manufacturer's written instructions. Attach perimeter wall track or angle where grid suspension systems meet vertical surfaces. Mechanically join main beam and cross-furring members to each other and butt-cut to fit into wall track.
- B. Installation Tolerances for Grid Suspension Systems: Install suspension systems that are level to within **1/8 inch in 12 ft.** measured lengthwise on each member that will receive finishes and transversely between parallel members that will receive finishes.

END OF SECTION 092216

SECTION 092900 - GYPSUM BOARD

PART 1 - GENERAL

1.1 SUMMARY

A. Section Includes:

1. Interior gypsum board.
2. Tile backing panels.
3. Trim accessories.

B. Related Requirements:

1. Section 079219 "Acoustical Joint Sealants" for acoustical joint sealants installed in gypsum board assemblies.
2. Section 092116.23 "Gypsum Board Shaft Wall Assemblies" for steel shaft wall framing, gypsum shaft liners, and other components of shaft wall assemblies.
3. Section 092216 "Non-Structural Metal Framing" for nonstructural steel framing and suspension systems that support gypsum board panels.

1.2 ACTION SUBMITTALS

A. Product Data: For each type of product.

B. Shop Drawings:

1. Locations and installation of control and expansion joints, including plans, elevations, sections, and attachment details.

1.3 DELIVERY, STORAGE, AND HANDLING

- A. Store materials inside under cover and keep them dry and protected against weather, condensation, direct sunlight, construction traffic, and other potential causes of damage. Stack panels flat and supported on risers on a flat platform to prevent sagging.

1.4 FIELD CONDITIONS

- A. Environmental Limitations: Comply with ASTM C840 requirements or manufacturer's written instructions, whichever are more stringent.
- B. Do not install paper-faced gypsum panels until installation areas are enclosed and conditioned.

- C. Do not install panels that are wet, moisture damaged, or mold damaged.
 - 1. Indications that panels are wet or moisture damaged include, but are not limited to, discoloration, sagging, or irregular shape.
 - 2. Indications that panels are mold damaged include, but are not limited to, fuzzy or splotchy surface contamination and discoloration.

PART 2 - PRODUCTS

2.1 SOURCE LIMITATIONS

- A. Obtain each type of gypsum panel and joint finishing material from single source with resources to provide products of consistent quality in appearance and physical properties.

2.2 PERFORMANCE REQUIREMENTS

- A. Fire-Resistance-Rated Assemblies: For fire-resistance-rated assemblies, provide materials and construction identical to those tested in assembly indicated on Drawings in accordance with ASTM E119; tested by a qualified testing agency.
- B. STC-Rated Assemblies: For STC-rated assemblies, provide materials and construction identical to those tested in assembly indicated on Drawings in accordance with ASTM E90 and classified in accordance with ASTM E413; tested by a qualified testing agency.

2.3 GYPSUM BOARD, GENERAL

- A. Size: Provide panel products in maximum lengths and widths available that will minimize joints in each area and that correspond with support system specified or indicated on Drawings.

2.4 INTERIOR GYPSUM BOARD

- A. Gypsum Wallboard: ASTM C1396/C1396M.
 - 1. Manufacturers: Subject to compliance with requirements, available manufacturers offering products that may be incorporated into the Work include, but are not limited to, the following:
 - a. American Gypsum
 - b. CertainTeed; SAINT-GOBAIN
 - c. Georgia-Pacific Gypsum LLC
 - d. Gold Bond Building Products, LLC provided by National Gypsum Company
 - e. PABCO Gypsum
 - f. USG Corporation

2. Thickness: 5/8 inch.
3. Long Edges: Tapered.

B. Gypsum Board, Type X: ASTM C1396/C1396M.

1. Manufacturers: Subject to compliance with requirements, available manufacturers offering products that may be incorporated into the Work include, but are not limited to, the following:
 - a. American Gypsum
 - b. CertainTeed; SAINT-GOBAIN
 - c. Georgia-Pacific Gypsum LLC
 - d. Gold Bond Building Products, LLC provided by National Gypsum Company
 - e. PABCO Gypsum
 - f. Panel Rey
 - g. USG Corporation
2. Thickness: **5/8 inch.**
3. Long Edges: Tapered.

C. Glass-Mat Interior Gypsum Board: ASTM C1658/C1658M; manufactured with fiberglass mat laminated to both sides and designed for interior use.

1. Manufacturers: Subject to compliance with requirements, available manufacturers offering products that may be incorporated into the Work include, but are not limited to, the following:
 - a. CertainTeed; SAINT-GOBAIN
 - b. Georgia-Pacific Gypsum LLC
 - c. Gold Bond Building Products, LLC provided by National Gypsum Company
 - d. PABCO Gypsum
 - e. Panel Rey
 - f. USG Corporation
2. Core: 5/8 inch.
3. Mold Resistance: ASTM D3273, score of 10 as rated in accordance with ASTM D3274.

2.5 TILE BACKING PANELS

A. Cementitious Backer Units: ANSI A118.9 and ASTM C1288 or ASTM C1325, with manufacturer's standard edges.

1. Manufacturers: Subject to compliance with requirements, available manufacturers offering products that may be incorporated into the Work include, but are not limited to, the following:
 - a. James Hardie Building Products, Inc.
 - b. PermaBASE Building Products, LLC provided by National Gypsum Company

c. USG Corporation

2. Thickness: **5/8 inch**.
3. Mold Resistance: ASTM D3273, score of 10 as rated in accordance with ASTM D3274.

2.6 TRIM ACCESSORIES

A. Interior Trim: ASTM C1047.

1. Material: Galvanized-steel sheet or aluminum-coated steel sheet, rolled zinc, plastic, or paper-faced galvanized-steel sheet.
2. Shapes:
 - a. Cornerbead.
 - b. LC-Bead: J-shaped; exposed long flange receives joint compound.
 - c. Expansion (control) joint.

2.7 JOINT TREATMENT MATERIALS

A. General: Comply with ASTM C475/C475M requirements.

1. Mold-Resistant Joint Compound: Use mold-resistant formulations with mold-resistant panel products.

B. Joint Tape:

1. Interior Gypsum Board: Paper.
2. Glass-Mat Gypsum Sheathing Board: 10-by-10 glass mesh.
3. Tile Backing Panels: As recommended in writing by panel manufacturer.

C. Joint Compound for Interior Gypsum Board: For each coat, use formulation that is compatible with other compounds applied on previous or for successive coats.

1. Prefilling: At open joints and damaged surface areas, use setting-type taping compound.
2. Embedding and First Coat: For embedding tape and first coat on joints, fasteners, and trim flanges, use setting-type taping compound.
 - a. Use setting-type compound for installing paper-faced metal trim accessories.
3. Fill Coat: For second coat, use setting-type, sandable topping compound.
4. Finish Coat: For third coat, use setting-type, sandable topping compound.
5. Skim Coat: For final coat of Level 5 finish, use setting-type, sandable topping compound.

D. Joint Compound for Tile Backing Panels:

1. Glass-Mat, Water-Resistant Backing Panel: As recommended in writing by backing panel manufacturer.
2. Cementitious Backer Units: As recommended in writing by backer unit manufacturer.
3. Water-Resistant Gypsum Backing Board: Use setting-type taping compound and setting-type, sandable topping compound.

2.8 AUXILIARY MATERIALS

- A. Provide auxiliary materials that comply with referenced installation standards and manufacturer's written instructions.
- B. Laminating Adhesive: Adhesive or joint compound recommended in writing by manufacturer for directly adhering gypsum panels to continuous substrate.
- C. Steel Drill Screws: ASTM C1002 unless otherwise specified or indicated on Drawings.
 1. Use screws complying with ASTM C954 for fastening panels to steel members from **0.033 to 0.112 inch** thick.
 2. For fastening cementitious backer units, use screws of type and size recommended in writing by panel manufacturer.
- D. Sound-Attenuation Blankets: ASTM C665, Type I (blankets without membrane facing) produced by combining thermosetting resins with mineral fibers as follows:
 1. Non-Fire-Resistance-Rated Assemblies: Glass or slag or rock wool.
 2. Fire-Resistance-Rated Assemblies: Comply with mineral-fiber requirements of assembly.
- E. Acoustical Sealant: As specified in Section 079219 "Acoustical Joint Sealants."
- F. Thermal Insulation: As specified in Section 072100 "Thermal Insulation."
- G. Primer: As recommended in writing by textured finish manufacturer.

PART 3 - EXECUTION

3.1 EXAMINATION

- A. Examine areas and substrates including welded hollow-metal frames and support framing, with Installer present, for compliance with requirements and other conditions affecting performance of the Work.
- B. Examine panels before installation. Reject panels that are wet, moisture damaged, and mold damaged.
- C. Proceed with installation only after unsatisfactory conditions have been corrected.

3.2 INSTALLATION AND FINISHING OF PANELS, GENERAL

- A. Comply with ASTM C840 requirements.
- B. Install ceiling panels across framing to minimize the number of abutting end joints and to avoid abutting end joints in central area of each ceiling. Stagger abutting end joints of adjacent panels not less than one framing member.
- C. Install panels with face side out. Butt panels together for a light contact at edges and ends with not more than **1/16 inch** of open space between panels. Do not force into place.
- D. Locate edge and end joints over supports, except in ceiling applications where intermediate supports or gypsum board back-blocking is provided behind end joints. Do not place tapered edges against cut edges or ends. Stagger vertical joints on opposite sides of partitions. Do not make joints other than control joints at corners of framed openings.
- E. Form control and expansion joints with space between edges of adjoining gypsum panels.
- F. Cover both faces of support framing with gypsum panels in concealed spaces (above ceilings, etc.), except in chases braced internally.
 - 1. Unless concealed application is indicated or required for sound, fire, air, or smoke ratings, coverage may be accomplished with scraps of not less than **8 sq. ft.** in area.
 - 2. Fit gypsum panels around ducts, pipes, and conduits.
 - 3. Where partitions intersect structural members projecting below underside of floor/roof slabs and decks, cut gypsum panels to fit profile formed by structural members; allow **1/4- to 3/8-inch-** wide joints to install sealant.
- G. Isolate perimeter of gypsum board applied to non-load-bearing partitions at structural abutments. Provide **1/4- to 1/2-inch-** wide spaces at these locations and trim edges with edge trim where edges of panels are exposed. Seal joints between edges and abutting structural surfaces with acoustical sealant.
- H. Attachment to Steel Framing: Attach panels so leading edge or end of each panel is attached to open (unsupported) edges of stud flanges first.
- I. STC-Rated Assemblies: Seal construction at perimeters, behind control joints, and at openings and penetrations with a continuous bead of acoustical sealant. Install acoustical sealant at both faces of partitions at perimeters and through penetrations. Comply with ASTM C919 requirements and with manufacturer's written instructions for locating edge trim and closing off sound-flanking paths around or through assemblies, including sealing partitions above acoustical ceilings.
 - 1. Interior partitions rates as Acoustic: Acoustic Attenuation: STC of 45-49 calculated in accordance with ASTM E414, based on tests conducted in accordance with ASTM 390.

- J. Install sound-attenuation blankets before installing gypsum panels unless blankets are readily installed after panels have been installed on one side.

3.3 INSTALLATION OF INTERIOR GYPSUM BOARD

- A. Install interior gypsum board in the following locations:

1. Gypsum Wallboard: Vertical surfaces unless otherwise indicated.
2. Gypsum Board, Type X: Where required for fire-resistance-rated assembly.
3. Flexible Gypsum Board: Apply in double layer at curved assemblies.
4. Gypsum Ceiling Board: Ceiling surfaces.
5. Acoustically Enhanced Gypsum Board: As needed to meet acoustic requirements indicated on Drawings.

- B. Single-Layer Application:

1. On ceilings, apply gypsum panels before wall/partition board application to greatest extent possible and at right angles to framing unless otherwise indicated on Drawings.
2. On partitions/walls, apply gypsum panels unless otherwise specified or indicated on Drawings or required by fire-resistance-rated assembly, and minimize end joints.
 - a. Stagger abutting end joints not less than one framing member in alternate courses of panels.
 - b. At stairwells and other high walls, install panels horizontally unless otherwise indicated on Drawings or required by fire-resistance-rated assembly.
3. On Z-shaped furring members, apply gypsum panels vertically (parallel to framing) with no end joints. Locate edge joints over furring members.
4. Fastening Methods: Apply gypsum panels to supports with steel drill screws.

- C. Multilayer Application:

1. On partitions/walls, apply gypsum board indicated for base layers and face layers vertically (parallel to framing) with joints of base layers located over studs or furring members and face-layer joints offset at least one stud or furring member with base-layer joints unless otherwise indicated on Drawings or required by fire-resistance-rated assembly. Stagger joints on opposite sides of partitions.
2. On Z-shaped furring members, apply base layer vertically (parallel to framing) and face layer either vertically (parallel to framing) or horizontally (perpendicular to framing) with vertical joints offset at least one furring member. Locate edge joints of base layer over furring members.

- D. Curved Surfaces:

1. Install panels horizontally (perpendicular to supports) and unbroken, to extent possible, across curved surface plus **12-inch-** long straight sections at ends of curves and tangent to them.

2. For double-layer construction, fasten base layer to studs with screws **16 inches** o.c. Center gypsum board face layer over joints in base layer, and fasten to studs with screws spaced **12 inches** o.c.

3.4 INSTALLATION OF TILE BACKING PANELS

- A. Glass-Mat, Water-Resistant Backing Panels: Comply with manufacturer's written installation instructions and install at locations indicated to receive tile. Install with **1/4-inch** gap where panels abut other construction or penetrations.
- B. Cementitious Backer Units: ANSI A108.11, at showers, tubs, and where indicated on Drawings.
- C. Water-Resistant Backing Board: Install where indicated with **1/4-inch** gap where panels abut other construction or penetrations.
- D. Where tile backing panels abut other types of panels in same plane, shim surfaces to produce a uniform plane across panel surfaces.

3.5 INSTALLATION OF TRIM ACCESSORIES

- A. General: For trim with back flanges intended for fasteners, attach to framing with same fasteners used for panels. Otherwise, attach trim in accordance with manufacturer's written instructions.
- B. Control Joints: Install control joints in accordance with ASTM C840 and in specific locations approved by Architect for visual effect.
- C. Interior Trim: Install in the following locations:
 1. Cornerbead: Install at outside corners.
 2. LC-Bead: Install at exposed panel edges.

3.6 APPLICATION OF JOINT TREATMENT MATERIALS

- A. Finishing Panel Products: Treat joints, interior angles, edge trim, control joints, penetrations, fastener heads, surface defects, and elsewhere as required to prepare panel surfaces for decoration. Promptly remove residual joint compound from adjacent surfaces.
- B. Prefill open joints and damaged surface areas.
- C. Apply joint tape over panel joints, except for trim products specifically indicated as not intended to receive tape.
- D. Interior Gypsum Board: Finish panels to levels indicated below and in accordance with ASTM C840:

1. Level 1: Fire-resistance-rated wall areas above finished ceilings, whether or not accessible in the completed construction, and concealed areas
2. Level 2: In utility area, behind cabinetry, and on backing board to receive tile finish.
3. Level 4: Walls and ceilings to receive paint finish, unless noted otherwise.
 - a. Primer and its application to surfaces are specified in Section 099123 "Interior Painting."
4. Level 5: Walls and ceilings to receive semi-gloss or gloss paint finish and other areas specifically indicated. Walls and ceilings with graphic wallcoverings GR-WC to receive Level 5 finish.
 - a. Primer and its application to surfaces are specified in Section 099123 "Interior Painting."

- E. Glass-Mat Faced Panels: Finish in accordance with manufacturer's written instructions.
- F. Cementitious Backer Units: Finish in accordance with manufacturer's written instructions.

3.7 PROTECTION

- A. Protect adjacent surfaces from joint compound and promptly remove from floors and other non-gypsum board surfaces. Repair surfaces stained, marred, or otherwise damaged during gypsum board installation and finishing.
- B. Protect installed products from damage from weather, condensation, direct sunlight, construction, and other causes during remainder of the construction period.
- C. Remove and replace panels that are wet, moisture damaged, and mold damaged.
 1. Indications that panels are wet or moisture damaged include, but are not limited to, discoloration, sagging, or irregular shape.
 2. Indications that panels are mold damaged include, but are not limited to, fuzzy or splotchy surface contamination and discoloration.

END OF SECTION 092900

SECTION 093013 - CERAMIC TILING

PART 1 - GENERAL

1.1 SUMMARY

A. Section Includes:

1. Porcelain tile.
2. Thresholds.
3. Setting material.
4. Grout materials.

B. Related Requirements:

1. for waterproofing under thickset mortar beds.
2. Section 079200 "Joint Sealants" for sealing of movement joints in tile surfaces.
3. Section 092900 "Gypsum Board" for tile backing panels.

1.2 DEFINITIONS

- A. General: Definitions in ANSI A108 series of tile installation standards and in ANSI A137.1 apply to Work of this Section unless otherwise specified.
- B. Face Size: Actual tile size, excluding spacer lugs.
- C. Large Format Tile: Tile with at least one edge **15 inches** or longer.
- D. Module Size: Actual tile size plus joint width indicated.

1.3 ACTION SUBMITTALS

- A. Product Data: For each type of product.
- B. Shop Drawings: Show locations, plans, and elevations, of each type of tile and tile pattern. Show widths, details, and locations of movement joints in tile substrates and finished tile surfaces.
- C. Samples for Verification:
1. Full-size units of each type and composition of tile and for each color and finish required.
 2. Full-size units of each type of trim and accessory for each color and finish required.
 3. Stone thresholds in **6-inch** lengths.
 4. Metal flooring transitions **6-inch** lengths.

1.4 INFORMATIONAL SUBMITTALS

- A. Qualification Data: For Installer.
- B. Product Certificates: For each type of product, including product use classification.

1.5 MAINTENANCE MATERIAL SUBMITTALS

- A. Extra Stock Material: Furnish extra materials, from the same production run, to Owner that match products installed and that are packaged with protective covering for storage and identified with labels describing contents.
 - 1. Tile and Trim Units: Furnish quantity of full-size units equal to 3 percent of amount installed for each type, composition, color, pattern, and size indicated.
 - 2. Grout: Furnish quantity of grout equal to 3 percent of amount installed for each type, composition, and color indicated.

1.6 QUALITY ASSURANCE

- A. Installer Qualifications:
 - 1. Installer is a Five-Star member of the National Tile Contractors Association or a Trowel of Excellence member of the Tile Contractors' Association of America.

1.7 DELIVERY, STORAGE, AND HANDLING

- A. Deliver and store packaged materials in original containers with seals unbroken and labels intact until time of use. Comply with requirements in ANSI A137.1 for labeling tile packages.
- B. Store tile and cementitious materials on elevated platforms, under cover, and in a dry location.
- C. Store aggregates where grading and other required characteristics can be maintained and contamination can be avoided.
- D. Store liquid materials in unopened containers and protected from freezing.

1.8 FIELD CONDITIONS

- A. Environmental Limitations: Do not install tile until construction in spaces is complete and ambient temperature and humidity conditions are maintained at the levels indicated in referenced standards and manufacturer's written instructions.

1.9 WARRANTY

- A. System Warranty: Manufacturer's non-prorated comprehensive warranty that agrees to repair and replace defective installation areas, material, and labor that fail under normal usage within specified warranty period.
 - 1. Warranty Period: Five years from date of Product Purchase. Confirm with manufacturer for each product.

PART 2 - PRODUCTS

2.1 SOURCE LIMITATIONS

- A. Tile: Obtain tile of each type from single source or producer.
 - 1. Obtain tile of each type and color or finish from same production run and of consistent quality in appearance and physical properties for each contiguous area.
- B. Accessory Products: Obtain each of the following products specified in this Section from a single manufacturer:
 - 1. Stone thresholds.
 - 2. Backer units.

2.2 PRODUCTS, GENERAL

- A. ANSI Ceramic Tile Standard: Provide tile that complies with ANSI A137.1 for types, compositions, and other characteristics indicated.
 - 1. Provide tile complying with Standard Grade requirements unless otherwise indicated.
- B. ANSI Standards for Tile Installation Materials: Provide materials complying with ANSI A108.02, ANSI standards referenced in other Part 2 articles, ANSI standards referenced by TCNA installation methods specified in tile installation schedules, and other requirements specified.
- C. Factory Blending: For tile exhibiting color variations within ranges, blend tile in factory and package so tile units taken from one package show same range in colors as those taken from other packages and match approved Samples.
- D. Mounting: For factory-mounted tile, provide back- or edge-mounted tile assemblies as standard with manufacturer unless otherwise indicated.
- E. Provide setting and grout materials from same manufacturer.

2.3 PORCELAIN TILE

A. Porcelain Tile Type (T-1): Glazed.

1. Basis-of-Design Product: Subject to compliance with requirements, provide Platform Surfaces, Cove or Approved Equivalent by one of the following:
 - a. American Olean; a brand of Dal-Tile Corporation
 - b. Crossville, Inc.
 - c. Daltile; a brand of Dal-Tile Corporation
 - d. Florida Tile, Inc.
 - e. Florim USA
 - f. Interceramic
 - g. Iris Ceramics U.S., a division of Stonepeak Ceramics, Inc.
 - h. Marazzi USA; a brand of Dal-Tile Corporation
 - i. Portobello America, Inc.
 - j. Vitromex USA, Inc.
2. Certification: Tile certified by the Porcelain Tile Certification Agency.
3. Face Size: 12 by 24 inches.
4. Face Size Variation: Rectified.
5. Thickness: 9 mm.
6. Product Use Classification: Interior, Wet (IW).
7. Tile Color, Glaze, and Pattern: Per Finish Schedule.
8. Grout Color: GR-1.
9. Trim Units: Coordinated with sizes and coursing of adjoining flat tile where applicable and matching characteristics of adjoining flat tile. Provide shapes as follows, selected from manufacturer's standard shapes:
 - a. Base Cap: Surface bullnose, module size same as adjoining flat tile.
 - b. Wainscot Cap: Surface bullnose, module size same as adjoining flat tile.
 - c. Wainscot Cap for Flush Conditions: Regular flat tile for conditions where tile wainscot is shown flush with wall surface above it; same size as adjoining flat tile.
 - d. External Corners: Surface bullnose, module size same as adjoining flat tile.
 - e. Internal Corners: Field-buffed square corners.
 - f. Tapered Transition Tile: Shape designed to effect transition between thickness of tile floor and adjoining floor finishes of different thickness, tapered to provide reduction in thickness from **1/2 to 1/4 inch** across nominal **4-inch** dimension.

B. Porcelain Tile Type 2 (T-2): Glazed.

1. Manufacturers: Subject to compliance with requirements, provide products by the following:
 - a. Platform Surfaces
2. Certification: Tile certified by the Porcelain Tile Certification Agency.
3. Face Size: 12 by 24 inches.
4. Product Use Classification: Interior, Wet (IW).

5. Tile Color, Glaze, and Pattern: Infinity Sky Wave.
6. Grout Color: GR-2.

C. Porcelain Tile Type 3 (T-3): Glazed.

1. Manufacturers: Subject to compliance with requirements, provide products by the following:
 - a. Stonesource
2. Certification: Tile certified by the Porcelain Tile Certification Agency.
3. Face Size: 5 by 5 inches.
4. Thickness: 8.8 mm.
5. Product Use Classification: Interior, Wet (IW).
6. Tile Color, Glaze, and Pattern: Palma Craft, Cotto Glossy.
7. Grout Color: GR-3.

D. Porcelain Tile Type 4 (T-4): Glazed.

1. Manufacturers: Subject to compliance with requirements, provide products by the following:
 - a. Stonesource
2. Certification: Tile certified by the Porcelain Tile Certification Agency.
3. Face Size: 2.5 by 5 inches.
4. Thickness: 8.8 mm.
5. Product Use Classification: Interior, Wet (IW).
6. Tile Color, Glaze, and Pattern: Palma Craft Cotto, Glossy.
7. Grout Color: GR-3.

E. Porcelain Tile Type 5 (T-5): Glazed.

1. Manufacturers: Subject to compliance with requirements, provide products by the following:
 - a. Stonesource
2. Certification: Tile certified by the Porcelain Tile Certification Agency.
3. Face Size: 5 by 5 inches.
4. Thickness: 8.8 mm.
5. Product Use Classification: Interior, Dry (ID).
6. Tile Color, Glaze, and Pattern: Palma Craft, Marine, Glossy.
7. Grout Color: GR-4.

F. Porcelain Tile Type 6: Glazed.

1. Manufacturers: Subject to compliance with requirements, provide products by the following:
 - a. Stonesource

2. Certification: Tile certified by the Porcelain Tile Certification Agency.
3. Face Size: 2-1/2 by 5 inches.
4. Thickness: 8.8 mm.
5. Product Use Classification: Interior, Dry (ID).
6. Tile Color, Glaze, and Pattern: Palma Craft, Marine, Glossy.
7. Grout Color: GR-4.

G. Porcelain Tile Type 7 (T-7): Glazed.

1. Manufacturers: Subject to compliance with requirements, provide products by the following:
 - a. Platform Surfaces
2. Certification: Tile certified by the Porcelain Tile Certification Agency.
3. Face Size: 4-1/2 by 9 inches.
4. Thickness: 8.5 mm.
5. Product Use Classification: Interior, Dry (ID).
6. Tile Color, Glaze, and Pattern: Kit Kats Midnight, Glossy.
7. Grout Color: GR-5.
8. Precoat with temporary protective coating.

H. Porcelain Tile Type 8 (T-8): Glazed.

1. Manufacturers: Subject to compliance with requirements, provide products by the following:
 - a. Tilebar
2. Certification: Tile certified by the Porcelain Tile Certification Agency.
3. Face Size: 3 by 12 inches.
4. Thickness: 8.10 mm.
5. Product Use Classification: Interior, Wet (IW).
6. Tile Color, Glaze, and Pattern: Rework Leather, Gray Blue.
7. Grout Color: GR-6.

I. Porcelain Tile Type 9 (T-9): Glazed.

1. Manufacturers: Subject to compliance with requirements, provide products by the following:
 - a. Platform Surfaces
2. Certification: Tile certified by the Porcelain Tile Certification Agency.
3. Face Size: 6 by 24 inches.
4. Face Size Variation: Rectified.
5. Thickness: 8.9 mm.
6. Product Use Classification: Interior, Dry (ID).
7. Tile Color, Glaze, and Pattern: Veneer World - Quarry Ledgestone River, Smoke.
8. Grout Color: GR-7.
9. Precoat with temporary protective coating.

J. Porcelain Tile Type 10 (T-10): Glazed.

1. Manufacturers: Subject to compliance with requirements, provide products by the following:
 - a. Platform Surfaces
2. Certification: Tile certified by the Porcelain Tile Certification Agency.
3. Face Size: 12 x 24 inches.
4. Face Size Variation: Rectified.
5. Thickness: 9 mm.
6. Product Use Classification: Interior, Wet (IW).
7. Tile Color, Glaze, and Pattern: Infinity, Sky.
8. Grout Color: GR-2.
9. Precoat with temporary protective coating.

2.4 GLAZED WALL TILE

- A. Accessories: Provide vitreous china accessories of type and size indicated; suitable for installing by same method as used for adjoining wall tile.
1. One soap holder for each shower and tub indicated.
 2. One paper holder at each water closet.
 3. Color and Finish: As selected by Architect from manufacturer's full range.

2.5 THRESHOLDS

- A. General: Fabricate to sizes and profiles indicated or required to provide transition between adjacent floor finishes.
1. Bevel edges at 1:2 slope, with lower edge of bevel aligned with or up to **1/16 inch** above adjacent floor surface. Finish bevel to match top surface of threshold. Limit height of threshold to **1/2 inch** or less above adjacent floor surface.

2.6 WATERPROOF MEMBRANES

- A. General: Manufacturer's standard product, selected from the following, that complies with ANSI A118.10 and ANSI A118.12 and is recommended by manufacturer for application indicated. Include reinforcement and accessories recommended by manufacturer.

2.7 CRACK ISOLATION MEMBRANES

- A. General: Manufacturer's standard product, selected from the following, that complies with ANSI A118.12 for standard performance and is recommended by manufacturer for application indicated. Include reinforcement and accessories recommended by manufacturer.

2.8 SETTING MATERIALS

- A. Portland Cement Mortar (Thickset) Installation Materials: ANSI A108.02.
1. Cleavage Membrane: Installer's option of material that complies with ANSI A108.02, paragraph 3.8.
 2. Reinforcing Wire Fabric: Galvanized, welded-wire fabric, **2 by 2 inches** by **0.062-inch** diameter; comply with ASTM A1064/A1064M except for minimum wire size.
 3. Expanded Metal Lath: Diamond-mesh lath complying with ASTM C847.
 - a. Base Metal and Finish for Interior Applications: Uncoated or zinc-coated (galvanized) steel sheet, with uncoated steel sheet painted after fabrication into lath.
 - b. Base Metal and Finish for Exterior Applications: Zinc-coated (galvanized) steel sheet.
 - c. Configuration over Studs and Furring: Flat.
 - d. Configuration over Solid Surfaces: Self-furring.
 4. Latex Additive: Manufacturer's standard water emulsion, serving as replacement for part or all of gaging water, of type specifically recommended by latex-additive manufacturer for use with field-mixed portland cement and aggregate mortar bed.

2.9 GROUT MATERIALS

- A. Sand-Portland Cement Grout: ANSI A108.10, consisting of white or gray cement and white or colored aggregate as required to produce color indicated.
- B. High-Performance Tile Grout (GR-1, GR-2, GR-3, GR-4, GR-5, GR-7): ANSI A118.7.
1. Basis-of-Design Product: Subject to compliance with requirements, provide Laticrete Permacolor Select or comparable product by one of the following:
 - a. ARDEX Americas
 - b. Bostik; Arkema
 - c. Custom Building Products
 - d. H.B. Fuller Construction Products Inc. / TEC
 - e. MAPEI Corporation
 - f. Parex, a Sika brand
 - g. Southern Grouts & Mortars, Inc
 - h. Summitville Tiles, Inc.
 2. Polymer Type:
 - a. Dry, redispersible form, prepackaged with other dry ingredients.
- C. High-Performance Tile Grout 6 (GR-6): ANSI A118.7.
1. Manufacturers: Subject to compliance with requirements, provide products by the following:

- a. Laticrete International, Inc.
2. Polymer Type:
 - a. Dry, redispersible form, prepackaged with other dry ingredients.
- D. Grout for PregROUTed Tile Sheets: Same product used in factory to pregROUT tile sheets.
- E. Trowelable Underlayments and Patching Compounds: Latex-modified, portland cement-based formulation provided or approved by manufacturer of tile-setting and adhesive materials for installations indicated.
- F. Vapor-Retarder Membrane: Polyethylene sheeting, ASTM D4397, **4.0 mils** thick.
- G. Temporary Protective Coating: Formulated to protect exposed surfaces of tile against adherence of mortar and grout; compatible with tile, mortar, and grout products and easily removable after grouting is completed without damaging grout or tile.
- H. Tile Cleaner: A neutral cleaner capable of removing soil and residue without harming tile and grout surfaces, specifically approved for materials and installations indicated by tile and grout manufacturers.
- I. Grout Sealer: Grout manufacturer's standard product for sealing grout joints that does not change color or appearance of grout.

PART 3 - EXECUTION

3.1 EXAMINATION

- A. Examine substrates, areas, and conditions where tile will be installed, with Installer present, for compliance with requirements for installation tolerances and other conditions affecting performance of the Work.
 1. Verify that substrates for setting tile are firm; dry; clean; free of coatings that are incompatible with tile-setting materials, including curing compounds and other substances that contain soap, wax, oil, or silicone; and comply with flatness tolerances required by ANSI A108.01 for installations indicated.
 2. Verify that concrete substrates for tile floors installed with adhesives bonded mortar bed or thinset mortar comply with surface finish requirements in ANSI A108.01 for installations indicated.
 - a. Verify that surfaces that received a steel trowel finish have been mechanically scarified.
 - b. Verify that protrusions, bumps, and ridges have been removed by sanding or grinding.
 3. Verify that installation of grounds, anchors, recessed frames, electrical and mechanical units of work, and similar items located in or behind tile has been completed.

4. Verify that joints and cracks in tile substrates are coordinated with tile joint locations; if not coordinated, adjust joint locations in consultation with Architect.

B. Proceed with installation only after unsatisfactory conditions have been corrected.

3.2 PREPARATION

A. Remove coatings, including curing compounds or other coatings, that are incompatible with tile-setting materials.

B. Fill cracks, holes, and depressions in concrete substrates for tile floors installed with adhesives or thinset mortar with trowelable leveling and patching compound specifically recommended by tile-setting material manufacturer.

C. Where indicated, prepare substrates to receive waterproof membrane by applying a reinforced mortar bed that complies with ANSI A108.1 and is sloped **1/4 inch per foot** toward drains.

D. Blending: For tile exhibiting color variations, verify that tile has been factory blended and packaged so tile units taken from one package show same range of colors as those taken from other packages and match approved Samples. If not factory blended, either return to manufacturer or blend tiles at Project site before installing.

E. Substrate Flatness:

1. For tile shorter than **15 inches**, confirm that structure or substrate is limited to variation of **1/4 inch in 10 ft.** from the required plane, and no more than **1/16 inch in 12 inches** when measured from tile surface high points.

2. For large format tile, tile with at least one edge **15 inches** or longer, confirm that structure or substrate is limited to **1/8 inch in 10 ft.** from the required plane, and no more than **1/16 inch in 24 inches** when measured from tile surface high points.

F. Field-Applied Temporary Protective Coating: If indicated under tile type or needed to prevent grout from staining or adhering to exposed tile surfaces, precoat them with continuous film of temporary protective coating, taking care not to coat unexposed tile surfaces.

3.3 INSTALLATION OF CERAMIC TILE SYSTEM

A. Install tile backing panels and treat joints in accordance with ANSI A108.11 and manufacturer's written instructions for type of application indicated.

B. Install waterproof membrane to comply with ANSI A108.13 and manufacturer's written instructions to produce waterproof membrane of uniform thickness that is bonded securely to substrate.

1. Allow waterproof membrane to cure and verify by testing that it is watertight before installing tile or setting materials over it.

- C. Install crack isolation membrane to comply with ANSI A108.17 and manufacturer's written instructions to produce membrane of uniform thickness that is bonded securely to substrate.
1. Allow crack isolation membrane to cure before installing tile or setting materials over it.
- D. Mix mortars and grouts to comply with referenced standards and mortar and grout manufacturers' written instructions.
1. Add materials, water, and additives in accurate proportions.
 2. Obtain and use type of mixing equipment, mixer speeds, mixing containers, mixing time, and other procedures to produce mortars and grouts of uniform quality with optimum performance characteristics for installations indicated.
- E. Install tile in accordance with TCNA's "Handbook for Ceramic, Glass, and Stone Tile Installation" for TCNA installation methods specified in tile installation schedules. Comply with parts of ANSI A108 series that are referenced in TCNA installation methods and specified in tile installation schedules, and apply to types of setting and grouting materials used.
1. For the following installations, follow procedures in ANSI A108 series of tile installation standards for providing 95 percent mortar coverage:
 - a. Tile floors in wet areas.
 - b. Tile floors consisting of tiles **8 by 8 inches** or larger.
 - c. Tile floors consisting of rib-backed tiles.
 2. Extend tile work into recesses and under or behind equipment and fixtures to form complete covering without interruptions unless otherwise indicated. Terminate work neatly at obstructions, edges, and corners without disrupting pattern or joint alignments.
 3. Accurately form intersections and returns. Perform cutting and drilling of tile without marring visible surfaces. Carefully grind cut edges of tile abutting trim, finish, or built-in items for straight aligned joints. Fit tile closely to electrical outlets, piping, fixtures, and other penetrations so plates, collars, or covers overlap tile.
 4. Provide manufacturer's standard trim shapes where necessary to eliminate exposed tile edges.
 5. Where accent tile differs in thickness from field tile, vary setting-bed thickness so that tiles are flush.
 6. Jointing Pattern: Lay tile in grid pattern unless otherwise indicated. Lay out tile work and center tile fields in both directions in each space or on each wall area. Lay out tile work to minimize use of pieces that are less than half of a tile. Provide uniform joint widths unless otherwise indicated.
 - a. For tile mounted in sheets, make joints between tile sheets same width as joints within tile sheets, so joints between sheets are not apparent in finished Work.
 - b. Where adjoining tiles on floor, base, walls, or trim are specified or indicated

- to be same size, align joints.
 - c. Where tiles are specified or indicated to be whole integer multiples of adjoining tiles on floor, base, walls, or trim, align joints unless otherwise indicated.
 - 7. Lay out tile wainscots to dimensions indicated or to next full tile beyond dimensions indicated.
 - F. Movement Joints: Provide movement joints and other sealant-filled joints, including control, contraction, and isolation joints, where indicated on Drawings. Form joints during installation of setting materials, mortar beds, and tile. Keep joints free of dirt, debris, and setting materials prior to filling with sealants. Do not saw-cut joints after installing tiles.
 - 1. Where joints occur in concrete substrates, locate joints in tile surfaces directly above them.
 - G. Metal Flooring Transitions: Install at locations indicated.
 - H. Metal Wall Trim: Install at locations indicated on Drawings.
 - I. Grout Sealer: Apply grout sealer to cementitious grout joints in tile floors in accordance with manufacturer's written instructions. As soon as sealer has penetrated grout joints, remove excess sealer and sealer from tile faces by wiping with soft cloth.
- 3.4 ADJUSTING AND CLEANING
- A. Remove and replace tile that is damaged or that does not match adjoining tile. Provide new matching units, installed as specified and in a manner to eliminate evidence of replacement.
 - B. Cleaning: On completion of placement and grouting, clean all ceramic tile surfaces so they are free of foreign matter.
 - 1. Remove grout residue from tile as soon as possible.
 - 2. Clean grout smears and haze from tile in accordance with tile and grout manufacturer's written instructions. Use only cleaners recommended by tile and grout manufacturers and only after determining that cleaners are safe to use by testing on samples of tile and other surfaces to be cleaned. Protect metal surfaces and plumbing fixtures from effects of cleaning. Flush surfaces with clean water before and after cleaning.
- 3.5 PROTECTION
- A. Protect installed tile work with kraft paper or other heavy covering during construction period to prevent staining, damage, and wear. If recommended by tile manufacturer, apply coat of neutral protective cleaner to completed tile walls and floors.
 - B. Prohibit foot and wheel traffic from tiled floors for at least seven days after grouting is

completed.

- C. Before final inspection, remove protective coverings and rinse neutral protective cleaner from tile surfaces.

3.6 INTERIOR CERAMIC TILE INSTALLATION SCHEDULE

- A. Standard Grout: ANSI A118.6 standard cement grout; use this type of grout all all locations, unless noted otherwise.
 - 1. Joints: Use sanded grout at joints 1/8" or wider; unsanded grout at joints less than 1/8 inch wide.
- B. Epoxy Grout: ANSI A118.3 chemical resistant and water-cleanable epoxy grout; use at toilet room locations unless noted otherwise.
- C. Backer Board: Cementitious type complying with ANSI A118.9; high density, glass fiber reinforced, 1/2 inch thick; 2 inch wide coated fiber glass tape for joints and corners.

END OF SECTION 093013

SECTION 095113 - ACOUSTICAL PANEL CEILINGS

PART 1 - GENERAL

1.1 SUMMARY

A. Section Includes:

1. Acoustical panels.

B. Related Requirements:

1. Section 095123 "Acoustical Tile Ceilings" for ceilings consisting of mineral-base acoustical tiles used with fully concealed suspension systems, stapling, or adhesive bonding.

C. Products furnished, but not installed under this Section, include anchors, clips, and other ceiling attachment devices to be cast in concrete.

1.2 ACTION SUBMITTALS

A. Product Data:

1. For each type of product.

B. Samples: For each exposed product and for each color and texture specified, **6 inches** in size.

1.3 INFORMATIONAL SUBMITTALS

A. Coordination Drawings: Reflected ceiling plans, drawn to scale, on which the following items are shown and coordinated with each other, using input from installers of the items involved:

1. Ceiling suspension-system members.
2. Structural members to which suspension systems will be attached.
3. Method of attaching hangers to building structure.
 - a. Furnish layouts for cast-in-place anchors, clips, and other ceiling attachment devices whose installation is specified in other Sections.
4. Carrying channels or other supplemental support for hanger-wire attachment where conditions do not permit installation of hanger wires at required spacing.
5. Size and location of initial access modules for acoustical panels.
6. Items penetrating finished ceiling and ceiling-mounted items including the following:

- a. Lighting fixtures.
 - b. Diffusers.
 - c. Grilles.
 - d. Speakers.
 - e. Sprinklers.
 - f. Access panels.
 - g. Perimeter moldings.
7. Show operation of hinged and sliding components covered by or adjacent to acoustical panels.
 8. Minimum Drawing Scale: **1/4 inch = 1 foot.**
- B. Qualification Data: For testing agency.
- C. Product Test Reports: For each acoustical panel ceiling, for tests performed by manufacturer and witnessed by a qualified testing agency.
- D. Field quality-control reports.
- 1.4 CLOSEOUT SUBMITTALS
- A. Maintenance Data: For finishes to include in maintenance manuals.
- 1.5 QUALITY ASSURANCE
- A. Mockups: Build mockups to verify selections made under Sample submittals, to demonstrate aesthetic effects, and to set quality standards for materials and execution.
1. Build mockup of typical ceiling area as indicated on Drawings.
 2. Approval of mockups does not constitute approval of deviations from the Contract Documents contained in mockups unless Architect specifically approves such deviations in writing.
 3. Subject to compliance with requirements, approved mockups may become part of the completed Work if undisturbed at time of Substantial Completion.
- 1.6 FIELD CONDITIONS
- A. Environmental Limitations: Do not install acoustical panel ceilings until spaces are enclosed and weathertight, wet-work in spaces is complete and dry, work above ceilings is complete, and ambient temperature and humidity conditions are maintained at the levels indicated for Project when occupied for its intended use.
1. Pressurized Plenums: Operate ventilation system for not less than 48 hours before beginning acoustical panel ceiling installation.

PART 2 - PRODUCTS

2.1 PERFORMANCE REQUIREMENTS

- A. Surface-Burning Characteristics: Comply with ASTM E84; testing by a qualified testing agency. Identify products with appropriate markings of applicable testing agency.
 - 1. Flame-Spread Index: Class A in accordance with ASTM E1264.
 - 2. Smoke-Developed Index: 50 or less.

2.2 ACOUSTICAL PANELS

- A. Acoustical Panels (AC-1):
 - 1. Manufacturers: Subject to compliance with requirements, provide products by the following:
 - a. Fact Design
 - 2. Color: As indicated on Drawings.
- B. Acoustical Panels 2 (AC-2):
 - 1. Manufacturers: Subject to compliance with requirements, provide products by the following:
 - a. Fact Design
 - 2. Acoustical Panel Standard: Provide manufacturer's standard panels in accordance with ASTM E1264 and designated by type, form, pattern, acoustical rating, and light reflectance unless otherwise indicated.
 - 3. Classification: Provide fire-resistance-rated panels as follows:
 - 4. Color: Blue.
 - 5. Thickness: 0.35 inch.
 - 6. Modular Size: **24 by 24 inches**.
- C. Acoustical Panels 3 (AC-3):
 - 1. Basis-of-Design Product: Subject to compliance with requirements, provide Armstrong; Tectum High NRC Panel, 'A' Method Attachment or comparable product by one of the following:
 - a. American Gypsum
 - b. Cardinal Acoustics, Inc.
 - c. CertainTeed; SAINT-GOBAIN
 - d. Rockfon; ROCKWOOL International
 - e. USG Corporation
 - 2. Acoustical Panel Standard: Provide manufacturer's standard panels in

accordance with ASTM E1264 and designated by type, form, pattern, acoustical rating, and light reflectance unless otherwise indicated.

3. Classification: Provide fire-resistance-rated panels as follows:
 - a. Pattern: .
4. Color: .
5. Light Reflectance (LR): Not less than 0.75.
6. Noise Reduction Coefficient (NRC): Not less than 0.40.
7. Edge/Joint Detail: As indicated by manufacturer's designation.
8. Thickness: **1 inch**.
9. Modular Size: As indicated in a schedule.

2.3 ACCESSORIES

- A. Attachment Devices: Size for five times the design load indicated in ASTM C635/C635M, Table 1, "Direct Hung," unless otherwise indicated. Comply with seismic design requirements.
 1. Anchors in Concrete: Anchors of type and material indicated below, with holes or loops for attaching hangers of type indicated and with capability to sustain, without failure, a load equal to five times that imposed by ceiling construction, as determined by testing in accordance with ASTM E488/E488M or ASTM E1512 as applicable, conducted by a qualified testing and inspecting agency.
 - a. Type: Postinstalled screw, drop-in, or adhesive anchors.
 - b. Corrosion Protection, Nickel-Copper Alloy: Components fabricated from nickel-copper-alloy rods complying with ASTM B164 for UNS No. N04400 alloy.
- B. Wire Hangers, Braces, and Ties: Provide wires as follows:
 1. Zinc-Coated, Carbon-Steel Wire: ASTM A641/A641M, Class 1 zinc coating, soft temper.
 2. Stainless Steel Wire: ASTM A580/A580M, Type 304, nonmagnetic.
 3. Nickel-Copper-Alloy Wire: ASTM B164, nickel-copper-alloy UNS No. N04400.
 4. Size: Wire diameter sufficient for its stress at three times hanger design load (ASTM C635/C635M, Table 1, "Direct Hung") will be less than yield stress of wire, but not less than **0.106-inch**- diameter wire.
- C. Hold-Down Clips: Manufacturer's standard hold-down.

PART 3 - EXECUTION

3.1 INSTALLATION OF ACOUSTICAL PANEL CEILINGS

- A. Install acoustical panel ceilings in accordance with ASTM C636/C636M and manufacturer's written instructions.

- B. Suspend ceiling hangers from building's structural members and as follows:
1. Install hangers plumb and free from contact with insulation or other objects within ceiling plenum that are not part of supporting structure or of ceiling suspension system.
 2. Where width of ducts and other construction within ceiling plenum produces hanger spacings that interfere with location of hangers at spacings required to support standard suspension-system members, install supplemental suspension members and hangers in form of trapezes or equivalent devices.
 3. Secure wire hangers to ceiling-suspension members and to supports above with a minimum of three tight turns. Connect hangers directly to structure or to inserts, eye screws, or other devices that are secure and appropriate for substrate and that will not deteriorate or otherwise fail due to age, corrosion, or elevated temperatures.
 4. Do not support ceilings directly from permanent metal forms or floor deck. Fasten hangers to cast-in-place hanger inserts, postinstalled mechanical or adhesive anchors, or power-actuated fasteners that extend through forms into concrete.
 5. Space hangers not more than **48 inches** o.c. along each member supported directly from hangers unless otherwise indicated; provide hangers not more than **8 inches** from ends of each member.
 6. Size supplemental suspension members and hangers to support ceiling loads within performance limits established by referenced standards.
- C. Install edge moldings and trim of type indicated at perimeter of acoustical ceiling area and where necessary to conceal edges of acoustical panels.
1. Screw attach moldings to substrate at intervals not more than **16 inches** o.c. and not more than **3 inches** from ends. Miter corners accurately and connect securely.
 2. Do not use exposed fasteners, including pop rivets, on moldings and trim.
- D. Install suspension-system runners so they are square and securely interlocked with one another. Remove and replace dented, bent, or kinked members.
- E. Install acoustical panels with undamaged edges and fit accurately into suspension-system runners and edge moldings. Scribe and cut panels at borders and penetrations to provide precise fit.
1. Arrange directionally patterned acoustical panels as follows:
 - a. As indicated on reflected ceiling plans.
 2. Paint cut edges of panel remaining exposed after installation; match color of exposed panel surfaces using coating recommended in writing for this purpose by acoustical panel manufacturer.

3.2 ERECTION TOLERANCES

- A. Moldings and Trim: Install moldings and trim to substrate and level with ceiling suspension system to a tolerance of **1/8 inch in 12 feet**, non-cumulative.

Intersect Studio, LLC
23046

Kalamazoo Crosstown
Parkway Facility
Kalamazoo, Michigan

END OF SECTION 095113

SECTION 095123 - ACOUSTICAL TILE CEILINGS

PART 1 - GENERAL

1.1 SUMMARY

A. Section Includes:

1. Acoustical tiles.

B. Related Requirements:

1. Section 095113 "Acoustical Panel Ceilings" for ceilings consisting of mineral-base and glass-fiber-base acoustical panels and exposed suspension systems.

1.2 ACTION SUBMITTALS

A. Product Data:

1. For each type of product.

B. Samples: For each exposed product and for each color and texture specified, **6 inches** in size.

1.3 INFORMATIONAL SUBMITTALS

A. Product Test Reports: For each acoustical tile ceiling, for tests performed by a qualified testing agency.

B. Evaluation Reports: For each acoustical tile ceiling suspension system and anchor and fastener type, from ICC-ES.

C. Field quality-control reports.

1.4 CLOSEOUT SUBMITTALS

A. Maintenance Data: For finishes to include in maintenance manuals.

1.5 MAINTENANCE MATERIAL SUBMITTALS

A. Furnish extra materials, from the same production run, that match products installed and that are packaged with protective covering for storage and identified with labels describing contents.

1. Acoustical Ceiling Units: Full-size tiles equal to 2 percent of quantity installed.
2. Suspension-System Components: Quantity of each concealed grid and exposed component equal to 2 percent of quantity installed.

1.6 QUALITY ASSURANCE

1.7 DELIVERY, STORAGE, AND HANDLING

- A. Deliver acoustical tiles, suspension-system components, and accessories to Project site and store them in a fully enclosed, conditioned space where they will be protected against damage from moisture, humidity, temperature extremes, direct sunlight, surface contamination, and other causes.
- B. Before installing acoustical tiles, permit them to reach room temperature and a stabilized moisture content.

1.8 FIELD CONDITIONS

PART 2 - PRODUCTS

2.1 SOURCE LIMITATIONS

- A. Source Limitations for Suspended Acoustical Tile Ceiling System: Obtain each type of acoustical ceiling tile and its suspension system from single source from single manufacturer.
- B. Source Limitations for Directly Attached Acoustical Tile Ceiling Tile: Obtain each type of acoustical ceiling tile from single source from single manufacturer.

2.2 PERFORMANCE REQUIREMENTS

- A. Surface-Burning Characteristics: Comply with ASTM E84; testing by a qualified testing agency. Identify products with appropriate markings of applicable testing agency.
 1. Flame-Spread Index: Class A in accordance with ASTM E1264.
 2. Smoke-Developed Index: 50 or less.

2.3 ACOUSTICAL TILES

- A. Acoustical Tiles (ACT-1):
 1. Basis-of-Design Product: Subject to compliance with requirements, provide Armstrong World Industries; 3251 Optima Square Tegular or Approved Equivalent by one of the following:
 - a. CertainTeed; SAINT-GOBAIN

- b. Rockfon; ROCKWOOL International
 - c. USG Corporation
 2. Acoustical Tile Standard: Provide manufacturer's standard tiles of configuration indicated that comply with ASTM E1264 classifications as designated by type, form, pattern, acoustical rating, and light reflectance unless otherwise indicated.
 3. Classification: Provide fire-resistance-rated tiles as follows:
 - a. Type and Form: Type B, Form B2.
 - b. Pattern: E (lightly textured).
 4. Color: White.
 5. Light Reflectance (LR): Not less than .95.
 6. Noise Reduction Coefficient (NRC): Not less than 0.95.
 7. Articulation Class (AC): Not less than 190.
 8. Edge/Joint Detail: Square Tegular, Square Lay-in.
 9. Thickness: 1 inch.
 10. Modular Size: 24 by 24 inches.
- B. Acoustical Tiles 2 (ACT-2):
 1. Basis-of-Design Product: Subject to compliance with requirements, provide Armstrong World Industries; 1952 Ultima Beveled Tegular or Approved Equivalent by one of the following:
 - a. CertainTeed; SAINT-GOBAIN
 - b. Rockfon; ROCKWOOL International
 - c. USG Corporation
 2. Acoustical Tile Standard: Provide manufacturer's standard tiles of configuration indicated that comply with ASTM E1264 classifications as designated by type, form, pattern, acoustical rating, and light reflectance unless otherwise indicated.
 3. Classification: Provide fire-resistance-rated tiles as follows:
 - a. Type and Form: Type A, Form A2.2.
 - b. Pattern: E (lightly textured) as indicated by manufacturer's designation.
 4. Color: White.
 5. Light Reflectance (LR): Not less than 0.87.
 6. Ceiling Attenuation Class (CAC): Not less than 40.
 7. Noise Reduction Coefficient (NRC): Not less than 0.60.
 8. Edge/Joint Detail: Beveled Tegulat, Square Lay-in.
 9. Thickness: **3/4 inch.**
 10. Modular Size: 24 by 24 inches.
- C. Acoustical Tiles 3 (ACT-3):
 1. Basis-of-Design Product: Subject to compliance with requirements, provide Armstrong World Industries; 3265 Optima Square Tegular or Approved Equivalent by one of the following:

- a. CertainTeed; SAINT-GOBAIN
 - b. Rockfon; ROCKWOOL International
 - c. USG Corporation
2. Acoustical Tile Standard: Provide manufacturer's standard tiles of configuration indicated that comply with ASTM E1264 classifications as designated by type, form, pattern, acoustical rating, and light reflectance unless otherwise indicated.
 3. Classification: Provide fire-resistance-rated tiles as follows:
 - a. Type and Form: Type B, Form B2.
 - b. Pattern: I (embossed).
 4. Color: White.
 5. Light Reflectance (LR): Not less than .88.
 6. Noise Reduction Coefficient (NRC): Not less than .95.
 7. Articulation Class (AC): Not less than 180 190.
 8. Edge/Joint Detail: Square Tegalur.
 9. Modular Size: As indicated in a schedule.
- D. Acoustical Tiles 4 (ACT-4):
1. Basis-of-Design Product: Subject to compliance with requirements, provide Armstrong World Industries; 1772 Dune Square Lay-in or Approved Equivalent by one of the following:
 - a. CertainTeed; SAINT-GOBAIN
 - b. Rockfon; ROCKWOOL International
 - c. USG Corporation
 2. Acoustical Tile Standard: Provide manufacturer's standard tiles of configuration indicated that comply with ASTM E1264 classifications as designated by type, form, pattern, acoustical rating, and light reflectance unless otherwise indicated.
 3. Classification: Provide fire-resistance-rated tiles as follows:
 - a. Type and Form: Type A, Form A1.2.
 - b. Pattern: E (lightly textured).
 4. Color: White.
 5. Light Reflectance (LR): Not less than 0.83.
 6. Ceiling Attenuation Class (CAC): Not less than 30.
 7. Noise Reduction Coefficient (NRC): Not less than 0.50.
 8. Edge/Joint Detail: Square Lay-in.
 9. Modular Size: 24 by 24 inches.
- E. Acoustical Tiles 5 (ACT-5):
1. Basis-of-Design Product: Subject to compliance with requirements, provide Armstrong; 1936 Ultima Health Zone Beveled Tegalur 9/16 or Approved Equivalent by one of the following:
 - a. CertainTeed; SAINT-GOBAIN

- b. Rockfon; ROCKWOOL International
 - c. USG Corporation
 2. Acoustical Tile Standard: Provide manufacturer's standard tiles of configuration indicated that comply with ASTM E1264 classifications as designated by type, form, pattern, acoustical rating, and light reflectance unless otherwise indicated.
 3. Classification: Provide tiles as follows:
 - a. Type and Form: Type A, Form 2.2.
 - b. Pattern: E (lightly textured).
 4. Color: White.
 5. Light Reflectance (LR): Not less than .86.
 6. Ceiling Attenuation Class (CAC): Not less than 38.
 7. Noise Reduction Coefficient (NRC): Not less than 0.70.
 8. Edge/Joint Detail: Beveled Tegular 9/16".
 9. Thickness: **3/4 inch**.
 10. Modular Size: 24 by 24 inches.
- F. Acoustical Tiles 6 (ACT-6):
 1. Basis-of-Design Product: Subject to compliance with requirements, provide Armstrong World Industries; 1850 Dune Square or Approved Equivalent by one of the following:
 - a. CertainTeed; SAINT-GOBAIN
 - b. Rockfon; ROCKWOOL International
 - c. USG Corporation
 2. Acoustical Tile Standard: Provide manufacturer's standard tiles of configuration indicated that comply with ASTM E1264 classifications as designated by type, form, pattern, acoustical rating, and light reflectance unless otherwise indicated.
 3. Classification: Provide fire-resistance-rated tiles as follows:
 - a. Type and Form: Type A, Form A1.2.
 - b. Pattern: E (lightly textured).
 4. Color: White.
 5. Light Reflectance (LR): Not less than .81.
 6. Ceiling Attenuation Class (CAC): Not less than 35.
 7. Noise Reduction Coefficient (NRC): Not less than 0.50.
 8. Edge/Joint Detail: Square Lay-in 15/16".
 9. Thickness: **5/8 inch**.
 10. Modular Size: 24 by 24 inches.
- G. Acoustical Tiles 7 (ACT-7):
 1. Basis-of-Design Product: Subject to compliance with requirements, provide Armstrong World Industries; 584 Cirrus Beveled Tegular 9/16 or Approved Equivalent by one of the following:

- a. CertainTeed; SAINT-GOBAIN
 - b. Rockfon; ROCKWOOL International
 - c. USG Corporation
2. Acoustical Tile Standard: Provide manufacturer's standard tiles of configuration indicated that comply with ASTM E1264 classifications as designated by type, form, pattern, acoustical rating, and light reflectance unless otherwise indicated.
 3. Classification: Provide fire-resistance-rated tiles as follows:
 - a. Type and Form: Type A, Form A1.2.
 - b. Pattern: F (heavily textured).
 4. Color: As indicated on Drawings.
 5. Light Reflectance (LR): Not less than 0.85.
 6. Ceiling Attenuation Class (CAC): Not less than 35.
 7. Edge/Joint Detail: Beveled Tegular 9/16.
 8. Thickness: **3/4 inch**.
 9. Modular Size: 24 by 24 inches.
- H. Acoustical Tiles 8 (ACT-8):
1. Basis-of-Design Product: Subject to compliance with requirements, provide Armstrong; Tegular Microperf or Approved Equivalent by one of the following:
 - a. CertainTeed; SAINT-GOBAIN
 - b. Rockfon; ROCKWOOL International
 - c. USG Corporation
 2. Acoustical Tile Standard: Provide manufacturer's standard tiles of configuration indicated that comply with ASTM E1264 classifications as designated by type, form, pattern, acoustical rating, and light reflectance unless otherwise indicated.
 3. Ceiling Attenuation Class (CAC): Not less than 27.
 4. Noise Reduction Coefficient (NRC): Not less than 0.70.
 5. Thickness: **3/4 inch**.
 6. Modular Size: 24 by 24 inches.

2.4 ACCESSORIES

- A. Attachment Devices: Size for five times the design load indicated in ASTM C635/C635M, Table 1, "Direct Hung," unless otherwise indicated. Comply with seismic design requirements.
1. Anchors in Concrete: Anchors of type and material indicated below, with holes or loops for attaching hangers of type indicated and with capability to sustain, without failure, a load equal to five times that imposed by ceiling construction, as determined by testing in accordance with ASTM E488/E488M or ASTM E1512 as applicable, conducted by a qualified testing and inspecting agency.
 - a. Type: Postinstalled expansion Postinstalled screw, drop-in, or adhesive anchors.

- b. Corrosion Protection, Carbon Steel: Components zinc plated in accordance with ASTM B633, Class SC 1 (mild) service condition.

B. Wire Hangers, Braces, and Ties: Provide wires as follows:

- 1. Zinc-Coated, Carbon-Steel Wire: ASTM A641/A641M, Class 1 zinc coating, soft temper.
- 2. Size: Wire diameter sufficient for its stress at three times hanger design load (ASTM C635/C635M, Table 1, "Direct Hung") will be less than yield stress of wire, but not less than **0.106-inch-** diameter wire.

C. Hanger Rods: Mild steel, zinc coated or protected with rust-inhibitive paint.

D. Flat Hangers: Mild steel, zinc coated or protected with rust-inhibitive paint.

E. Angle Hangers: Angles with legs not less than **7/8 inch** wide; formed with **0.04-inch-** thick, galvanized-steel sheet complying with ASTM A653/A653M, **G90** coating designation; with bolted connections and **5/16-inch-** diameter bolts.

2.5 ACOUSTICAL SEALANT

- A. Acoustical Sealant: As specified in Section 079219 "Acoustical Joint Sealants."

2.6 MISCELLANEOUS MATERIALS

- A. Staples: **5/16-inch-** long, divergent-point staples.

PART 3 - EXECUTION

3.1 EXAMINATION

- A. Examine substrates, areas, and conditions, including structural framing and substrates to which acoustical tile ceilings attach or abut, with Installer present, for compliance with requirements specified in this and other Sections that affect ceiling installation and anchorage and for compliance with requirements for installation tolerances and other conditions affecting performance of the Work.
- B. Examine acoustical tiles before installation. Reject acoustical tiles that are wet, moisture damaged, or mold damaged.
- C. Proceed with installation only after unsatisfactory conditions have been corrected.

3.2 PREPARATION

- A. Measure each ceiling area and establish layout of acoustical tiles to balance border widths at opposite edges of each ceiling. Avoid using less-than-half-width tiles at

borders unless otherwise indicated, and comply with layout shown on reflected ceiling plans.

- B. Layout openings for penetrations centered on the penetrating items.

3.3 INSTALLATION OF SUSPENDED ACOUSTICAL TILE CEILINGS

- A. Install suspended acoustical tile ceilings in accordance with ASTM C636/C636M and manufacturer's written instructions.
- B. Suspend ceiling hangers from building's structural members and as follows:
 - 1. Install hangers plumb and free from contact with insulation or other objects within ceiling plenum that are not part of supporting structure or of ceiling suspension system.
 - 2. Where width of ducts and other construction within ceiling plenum produces hanger spacings that interfere with location of hangers at spacings required to support standard suspension-system members, install supplemental suspension members and hangers in form of trapezes or equivalent devices.
 - 3. Secure wire hangers to ceiling suspension members and to supports above with a minimum of three tight turns. Connect hangers directly to structure or to inserts, eye screws, or other devices that are secure and appropriate for substrate and that will not deteriorate or otherwise fail due to age, corrosion, or elevated temperatures.
 - 4. Secure flat, angle, channel, and rod hangers to structure, including intermediate framing members, by attaching to inserts, eye screws, or other devices that are secure and appropriate for both the structure to which hangers are attached and the type of hanger involved. Install hangers in a manner that will not cause them to deteriorate or fail due to age, corrosion, or elevated temperatures.
 - 5. Do not support ceilings directly from permanent metal forms or floor deck. Fasten hangers to cast-in-place hanger inserts, postinstalled mechanical or adhesive anchors that extend through forms into concrete.
 - 6. When steel framing does not permit installation of hanger wires at spacing required, install carrying channels or other supplemental support for attachment of hanger wires.
 - 7. Do not attach hangers to steel deck tabs.
 - 8. Space hangers not more than **48 inches** o.c. along each member supported directly from hangers unless otherwise indicated; provide hangers not more than **8 inches** from ends of each member.
 - 9. Size supplemental suspension members and hangers to support ceiling loads within performance limits established by referenced standards.
- C. Install edge moldings and trim of type indicated at perimeter of acoustical ceiling area and where necessary to conceal edges of acoustical tiles.
 - 1. Apply acoustical sealant in a continuous ribbon concealed on back of vertical legs of moldings before they are installed.
 - 2. Screw attach moldings to substrate at intervals not more than **16 inches** o.c. and not more than **3 inches** from ends. Miter corners accurately and connect

- securely.
3. Do not use exposed fasteners, including pop rivets, on moldings and trim.
- D. Install suspension-system runners so they are square and securely interlocked with one another. Remove and replace dented, bent, or kinked members.
- E. Arrange directionally patterned acoustical tiles as follows:
1. As indicated on reflected ceiling plans.
 2. Install tiles in a basket-weave pattern.
- F. Install acoustical tiles in coordination with suspension system and exposed moldings and trim. Place splines or suspension-system flanges into kerfed edges of tiles so tile-to-tile joints are interlocked.
1. Fit adjoining tiles to form flush, tight joints. Scribe and cut tiles for accurate fit at borders and around penetrations through ceiling.
 2. Hold tile field in compression by inserting leaf-type, spring-steel spacers between tiles and moldings, spaced **12 inches** o.c.

3.4 FIELD QUALITY CONTROL

- A. Testing Agency: Engage a qualified testing agency to perform tests and inspections.
- B. Perform the following tests and inspections of completed installations of acoustical tile ceiling hangers and anchors and fasteners in successive stages and when installation of ceiling suspension systems on each floor has reached 20 percent completion, but no tiles have been installed. Do not proceed with installations of acoustical tile ceiling hangers for the next area until test results for previously completed installations of acoustical tile ceiling hangers show compliance with requirements.
1. Within each test area, testing agency will select one of every 10 power-actuated fasteners and postinstalled anchors used to attach hangers to concrete and will test them for **200 lbf** of tension; it will also select one of every two postinstalled anchors used to attach bracing wires to concrete and will test them for **440 lbf** of tension.
 2. When testing discovers fasteners and anchors that do not comply with requirements, testing agency will test those anchors not previously tested until 20 pass consecutively and then will resume initial testing frequency.
- C. Acoustical tile ceiling hangers, anchors, and fasteners will be considered defective if they do not pass tests and inspections.
- D. Prepare test and inspection reports.

3.5 ADJUSTING

- A. Clean exposed surfaces of acoustical tile ceilings, including trim and edge moldings. Comply with manufacturer's written instructions for cleaning and touchup of minor finish

damage.

- B. Remove and replace tiles and other ceiling components that cannot be successfully cleaned and repaired to permanently eliminate evidence of damage.

END OF SECTION 095123

SECTION 095426 - SUSPENDED WOOD CEILINGS

PART 1 - GENERAL

1.1 SUMMARY

- A. Section Includes:
 - 1. Wood, linear-panel ceilings.

1.2 ACTION SUBMITTALS

- A. Product Data: For each type of product.
- B. Shop Drawings: For suspended wood ceilings.
 - 1. Include reflected ceiling plans, sections, and details, drawn to scale, showing the following:
 - a. Wood ceiling patterns and joints.
 - b. Ceiling suspension members.
 - c. Method of attaching hangers to building structure and locations of cast-in-place anchors, clips, and other ceiling attachment devices whose installation is specified in other Sections.
 - d. Ceiling-mounted items including, but not limited to, light fixtures, diffusers, grilles, speakers, sprinklers, and access panels.
 - e. Ceiling perimeter and penetrations through ceiling; trim and moldings.
- C. Samples: For each exposed product and for each type, color, and finish specified, **12 inches** long by **12 inches** wide or full width in size.

1.3 INFORMATIONAL SUBMITTALS

- A. Product Test Reports: For each suspended wood ceiling, for tests performed by a qualified testing agency.
- B. Field quality control reports.

1.4 CLOSEOUT SUBMITTALS

- A. Maintenance Data: For finishes to include in maintenance manuals.

1.5 QUALITY ASSURANCE

- A. Testing Agency Qualifications: Accredited by National Voluntary Laboratory Accreditation Program for testing indicated.

1.6 DELIVERY, STORAGE, AND HANDLING

- A. Deliver ceiling components and accessories to Project site in original, unopened packages and store them in a fully enclosed, conditioned space where they are protected against damage from moisture, humidity, temperature extremes, direct sunlight, surface contamination, and other causes.
 - 1. Store materials flat and level, raised from the floor.
- B. Handle ceiling components and accessories in a manner that prevents damage.

1.7 PROJECT CONDITIONS

- A. Environmental Limitations: Do not install interior ceilings until spaces are enclosed and weathertight, wet-work in spaces is complete and dry, work above ceilings is complete, and HVAC system is operating and maintaining temperature and relative humidity at levels planned for building occupants during the remainder of the construction period.
 - 1. Store and acclimatize wood products in the spaces where they will be installed for a minimum of 72 hours immediately before ceiling installation.

PART 2 - PRODUCTS

2.1 WOOD, LINEAR-PANEL CEILINGS

- A. Wood-Veneer, Linear-Panel Ceilings: Linear panels fabricated from planks consisting of wood veneer adhered to backs and exposed surfaces of manufacturer's standard composite-wood cores. Planks run parallel to panel length.
 - 1. Manufacturers: Subject to compliance with requirements, provide products by the following:
 - a. Rulon
 - 2. Surface-Burning Characteristics: Provide products with the following characteristics when tested in accordance with ASTM E84:
 - a. Flame-Spread Index: 25 or less.
 - b. Smoke-Developed Index: 450 or less.
 - 3. Plank:

- a. Face Grade: Manufacturer's standard.
 - b. Adhesive: Manufacturer's standard that complies with "Performance Requirements" Article.
 - c. Species: White Oak.
 - d. Cut: Manufacturer's standard.
 - e. Width: **6 inches**.
 - f. Edges: Square.
 - g. Reveal Spacing: **3/4 inch** between long edges of planks.
 - h. Backing Boards: Manufacturer's standard; thick.
4. Panel Module: Per Finish Schedule.
- a. Attachment: Provide manufacturer's standard attachment hooks or clips for attaching panels to grid suspension system, spaced to support ceiling loads and in accordance with manufacturer's written installation instruction.
5. Accessories: Manufacturer's accessories required to provide a complete installation of ceiling in accordance with manufacturer's written installation instructions.
- a. Safety Cables: **24 inches**.
 - b. Panel Splice Plates: Manufacturer's standard.
 - c. Acoustic Felt: Manufacturer's standard, factory applied, black, backer with flame-spread index of 25 or less and smoke-developed index of 450 or less as determined by testing in accordance with ASTM E84.
 - d. End Caps: Manufacturer's standard units for exposed field-cut edges; solid wood finished to match planks.
 - e. Trim: As indicated on Drawings; with trim connectors recommended in writing by ceiling and suspension-system manufacturers.
6. Grid Suspension System: ASTM C635/C635M; recommended in writing by ceiling and suspension-system manufacturers for applications indicated; main- and cross-runner system complete with suspension-system components required to support ceiling units and other ceiling-supported construction.
- a. Material: ASTM A653/A653M, hot-dip galvanized, cold-rolled sheet steel, **G60** coating designation.
 - b. Finish: Manufacturer's Standard.

2.2 SUSPENSION-SYSTEM HANGERS, BRACES, AND TIES

- A. Attachment Devices: Size for 5 times the design load indicated in ASTM C635/C635M, Table 1, Direct Hung, unless otherwise indicated.
1. Cast-in-Place and Postinstalled Anchors in Concrete: Anchors of type and material indicated below, with holes or loops for attaching hangers of type indicated and with capability to sustain, without failure, a load equal to 5 times that imposed by ceiling construction as determined by testing in accordance with ASTM E488/E488M or ASTM E1512, as applicable, conducted by a qualified testing and inspecting agency.

- a. Type: Postinstalled expansion anchors.
 - b. Corrosion Protection:
 - 1) Carbon-steel components zinc plated to comply with ASTM B633, Class Fe/Zn 5 (0.005 mm) for Class SC service condition (mild).
 - 2) Stainless steel components complying with ASTM F593 and ASTM F594, Group 1 Alloy 304 or 316 for bolts; Alloy 304 or 316 for anchors.
 - 3) Components fabricated from nickel-copper-alloy rods complying with ASTM B164 for UNS No. N04400 alloy.
2. Power-Actuated Fasteners in Concrete: Fastener system of type suitable for application indicated, fabricated from corrosion-resistant materials, with clips or other accessory devices for attaching hangers of type indicated, and with capability to sustain, without failure, a load equal to 10 times that imposed by ceiling construction as determined by testing in accordance with ASTM E1190 conducted by a qualified testing and inspecting agency.
- B. Wire Hangers, Braces, and Ties: Provide wire complying with the following requirements:
1. Zinc-Coated, Carbon-Steel Wire: ASTM A641/A641M, Class 1 zinc coating, soft temper.
 2. Stainless Steel Wire: ASTM A580/A580M, Type 304, nonmagnetic.
 3. Nickel-Copper-Alloy Wire: ASTM B164 nickel-copper alloy UNS No. N04400.
 4. Size: Select wire diameter so its stress at 3 times the hanger design load indicated in ASTM C635/C635M, Table 1, Direct Hung is less than yield stress of wire, but provide not less than **0.135-inch-** diameter wire.
- C. Rods and Flat Hangers: Mild steel, zinc coated or protected with rust-inhibitive paint.
- D. Angle Hangers: Angles with legs not less than **7/8 inch** wide; formed from **0.04-inch-** thick, galvanized-steel sheet complying with ASTM A653/A653M, **G90** coating designation; with bolted connections and **5/16-inch-** diameter bolts.

PART 3 - EXECUTION

3.1 EXAMINATION

- A. Examine substrates, areas, and conditions, including structural framing and substrates to which suspended wood ceilings attach or abut, with Installer present, for compliance with requirements specified in this and other Sections that affect ceiling installation and anchorage, and with requirements for installation tolerances and other conditions affecting performance of suspended wood ceilings.
- B. Proceed with installation only after unsatisfactory conditions have been corrected.

3.2 PREPARATION

- A. Measure each ceiling area and establish layout of suspended wood ceilings.
 - 1. Balance border widths at opposite edges of each ceiling.
 - 2. Avoid using less-than-half-width units.

3.3 INSTALLATION OF SUSPENDED WOOD CEILINGS

- A. Comply with ASTM C636/C636M and seismic requirement indicated, in accordance with manufacturer's written instructions and CISCA's "Ceiling Systems Handbook."
- B. Suspend ceiling hangers from building's structural members and as follows:
 - 1. Install hangers plumb and free from contact with insulation or other objects within ceiling plenum that are not part of supporting structure or of ceiling suspension system.
 - 2. Splay hangers only where required to miss obstructions; offset resulting horizontal forces by bracing, countersplaying, or other equally effective means.
 - 3. Where width of ducts and other construction within ceiling plenum produces hanger spacings that interfere with location of hangers at spacings required to support standard suspension-system members, install supplemental suspension members and hangers in form of trapezes or equivalent devices.
 - 4. Secure wire hangers to ceiling suspension members and to supports above with a minimum of three tight turns in **3 inches**. Connect hangers directly either to structures or to inserts, eye screws, or other devices that are secure and appropriate for substrate to which hangers are attached and for type of hanger involved.
 - 5. Secure flat, angle, channel, and rod hangers to structure, including intermediate framing members, by attaching to inserts, eye screws, or other devices that are secure and appropriate for both structure to which hangers are attached and type of hanger involved. Install hangers in a manner that does not cause them to deteriorate or fail due to age, corrosion, or elevated temperatures.
 - 6. Do not support ceilings directly from permanent metal forms or floor deck. Fasten hangers to cast-in-place hanger inserts or postinstalled mechanical or adhesive anchors that extend through forms into concrete.
 - 7. When steel framing does not permit installation of hanger wires at spacing required, install carrying channels or other supplemental support for attachment of hanger wires.
 - 8. Do not attach hangers to steel deck tabs.
 - 9. Do not attach hangers to steel roof deck. Attach hangers to structural members.
 - 10. Space hangers not more than **48 inches** o.c. along each member supported directly from hangers unless otherwise indicated; provide hangers not more than **8 inches** from ends of each member.
 - 11. Size supplemental suspension members and hangers to support ceiling loads within performance limits established by referenced standards and publications.
- C. Secure bracing wires to ceiling suspension members and to supports with a minimum of four tight turns in **1-1/2 inches**. Suspend bracing from building's structural members

as required for hangers and without attaching to permanent metal forms, steel deck, or steel deck tabs. Fasten bracing wires into concrete with cast-in-place or postinstalled anchors.

- D. Install edge moldings and trim at perimeter of ceiling area and where necessary to conceal edges and ends of wood units.
 - 1. Screw-attach metal moldings to substrate at intervals of not more than **16 inches** o.c. and not more than **3 inches** from ends, leveling with ceiling suspension system to a tolerance of **1/8 inch in 12 ft.** Miter corners accurately and connect securely.
 - 2. Do not use exposed fasteners on moldings and trim.
- E. Grid Suspension Systems: Space main beams per manufacturer requirements.
 - 1. Install cross tees to form modules sized in accordance with manufacturer's written installation instructions.
 - 2. Remove and replace dented, bent, or kinked members.
- F. Install wood components and accessories in accordance with manufacturer's written instructions and to accommodate natural expansion and contraction of wood products resulting from fluctuations in humidity.
- G. Cut wood components for accurate fit at borders and at interruptions and penetrations by other work through ceilings.
 - 1. Stiffen edges of cut wood components as required to eliminate variations in flatness.
- H. Treat field-cut edges of wood components in accordance with manufacturer's written recommendations; finish exposed field cuts to match factory finish.
- I. Install wood components in coordination with suspension system and moldings and trim.
 - 1. Install wood components in patterns indicated on Drawings.

3.4 CLEANING

- A. Clean exposed surfaces of ceilings, including trim and edge moldings. Comply with manufacturer's written instructions for cleaning and touchup of minor finish damage. Remove and replace ceiling components that cannot be successfully cleaned and repaired to permanently eliminate evidence of damage, including dented units.

END OF SECTION 095426

SECTION 096513 - RESILIENT BASE AND ACCESSORIES

PART 1 - GENERAL

1.1 SUMMARY

A. Section Includes:

1. Thermoset rubber base.
2. Rubber stair treads.
3. Rubber molding accessories.
4. Vinyl molding accessories.

B. Related Requirements:

1. Section 024119 "Selective Demolition" for removing existing floor coverings.
2. Section 096516 "Resilient Sheet Flooring" for resilient rolled flooring.
3. Section 096519 "Resilient Tile and Plank Flooring" for modular resilient flooring.
4. Section 096813 "Tile Carpeting" for modular carpet tile flooring.

1.2 ACTION SUBMITTALS

A. Product Data: For each type of product.

1. Include manufacturer's written data on physical characteristics, durability, and fade resistance.
2. Include manufacturer's written installation instructions for each type of substrate.

B. Samples: For each exposed product and for each color and texture specified, not less than **12 inches** long.

C. Samples for Verification: For each type of exposed product indicated and for each color, texture, and pattern required in manufacturer's standard-size Samples, but not less than **12 inches** long.

D. Product Schedule: For resilient base and accessory products. Use same designations indicated on Drawings.

1.3 INFORMATIONAL SUBMITTALS

A. Product Test Reports: For resilient base and accessory products, for tests performed by a qualified testing agency.

1.4 MAINTENANCE MATERIAL SUBMITTALS

- A. Extra Stock Material: Furnish extra materials, from the same production run, to Owner that match products installed and that are packaged with protective covering for storage and identified with labels describing contents.
1. Furnish not less than **10 linear ft.** for every **500 linear ft.** or fraction thereof, of each type, color, pattern, and size of resilient product installed.

1.5 DELIVERY, STORAGE, AND HANDLING

- A. Store resilient products and installation materials in dry spaces protected from the weather, with ambient temperatures maintained within range recommended by manufacturer, but not less than **50 deg F** or more than **90 deg F**.

1.6 FIELD CONDITIONS

- A. Maintain ambient temperatures within range recommended by manufacturer, but not less than **70 deg F** or more than **95 deg F**, in spaces to receive resilient products during the following periods:
1. 48 hours before installation.
 2. During installation.
 3. 48 hours after installation.
- B. After installation and until Substantial Completion, maintain ambient temperatures within range recommended by manufacturer, but not less than **55 deg F** or more than **95 deg F**.
- C. Install resilient products after other finishing operations, including painting, have been completed.

PART 2 - PRODUCTS

2.1 PERFORMANCE REQUIREMENTS

2.2 RESILIENT BASE

- A. Thermoset Rubber Base (WB-1):
1. Manufacturers: Subject to compliance with requirements, provide products by the following:
 - a. Tarkett USA
 2. Classification: ASTM F1861, Type TS (rubber, vulcanized thermoset), Group I (solid, homogeneous).
 3. Style and Location:

- a. Style A, Straight: Per Drawings.
 4. Thickness: **0.125 inch**.
 5. Height: **4 inches**.
 6. Lengths: Coils in manufacturer's standard length.
 7. Outside Corners: Job formed or preformed.
 8. Inside Corners: Job formed or preformed.
 9. Colors: Per Finish Schedule.

- B. Rubber Base 2 (WB-2):
 1. Manufacturers: Subject to compliance with requirements, provide products by the following:
 - a. Tarkett USA
 2. Classification: ASTM F1861, Type TS (rubber, vulcanized thermoset), Group I (solid, homogeneous).
 3. Style and Location:
 - a. Style B, Cove: Provide in areas as indicated.
 - b. Shoe Moulding: Provide in areas indicated
 4. Height: 1-1/2 inches.
 5. Lengths: Coils in manufacturer's standard length.
 6. Outside Corners: Job formed or preformed.
 7. Inside Corners: Job formed or preformed.
 8. Colors: Per Finish Schedule.

- C. Rubber Base 3 (WB-3):
 1. Manufacturers: Subject to compliance with requirements, provide products by the following:
 - a. Tarkett USA
 2. Classification: ASTM F1861, Type TS (rubber, vulcanized thermoset), Group I (solid, homogeneous).
 3. Thickness: .35.
 4. Height: **6 inches** 1-1/2 inches.
 5. Lengths: Cut lengths **48 inches** long or coils in manufacturer's standard length.
 6. Outside Corners: Job formed or preformed.
 7. Inside Corners: Job formed or preformed.
 8. Colors: See Finish Schedule.

- D. Rubber Base 4 (WB-4):
 1. Manufacturers: Subject to compliance with requirements, provide products by the following:
 - a. Platform Surfaces

2. Classification: ASTM F1861, Type TS (rubber, vulcanized thermoset), Group I (solid, homogeneous).
3. Style and Location:
 - a. Style B, Cove: Per Drawings.
4. Height: 6 inches 1-1/2 inches.
5. Lengths: .
6. Outside Corners: Job formed or preformed.
7. Inside Corners: Job formed or preformed.
8. Colors: Per Finish Schedule.

E. Rubber Base 5 (WB-5):

1. Manufacturers: Subject to compliance with requirements, provide products by the following:
 - a. Tarkett USA
2. Classification: ASTM F1861, Type TS (rubber, vulcanized thermoset), Group I (solid, homogeneous).
3. Style and Location:
 - a. Style B, Cove: Per Drawings.
4. Height: 4 inches 1-1/2 inches.
5. Lengths: Cut lengths 48 inches long or coils in manufacturer's standard length.
6. Outside Corners: Job formed or preformed.
7. Inside Corners: Job formed or preformed.
8. Colors: Per Finish Schedule.

2.3 RESILIENT STAIR ACCESSORIES

A. Rubber Stair Treads (ST-1):

1. Manufacturers: Subject to compliance with requirements, provide products by the following:
 - a. Nora; Norament Arago Stairtreads
2. Classification: ASTM F2169, Type TS (rubber, vulcanized thermoset).
 - a. Class: 2 (pattern; embossed, grooved, or ribbed).
 - b. Group: 1 (embedded abrasive strips).
3. Nosing Style: Round.
4. Nosing Height: Coordinate with existing conditions.
5. Thickness: 5mm.
6. Size: Lengths and depths to fit each stair tread in one piece.

- B. Integral Risers: Smooth, flat; in height that fully covers substrate.
- C. Landing Tile: Matching treads; produced by same manufacturer who produced treads and recommended by manufacturer for installation with treads.
- D. Locations: Provide resilient stair accessories in areas indicated.
- E. Colors and Patterns: Per Finish Schedule.

2.4 RESILIENT MOLDING ACCESSORIES

- A. Rubber Molding Accessories :
 - 1. Accessory Description: reducer strip for resilient floor covering joiner for tile and carpet transition strips.
 - 2. Profile and Dimensions: As indicated.
- B. Vinyl Molding Accessories :
 - 1. Accessory Description: reducer strip for resilient floor covering transition strips.
 - 2. Profile and Dimensions: As indicated.
- C. Locations: Provide resilient molding accessories in areas indicated.
- D. Colors and Patterns: Architect to Review

2.5 INSTALLATION MATERIALS

- A. Trowelable Leveling and Patching Compounds: Latex-modified, portland-cement-based or blended hydraulic-cement-based formulation provided or approved by resilient-product manufacturer for applications indicated.
- B. Adhesives: Water-resistant type recommended in writing by resilient-product manufacturer for resilient products and substrate conditions indicated.
- C. Stair-Tread Nose Filler: Two-part epoxy compound recommended by resilient stair-tread manufacturer to fill nosing substrates that do not conform to tread contours.
- D. Floor Polish: Provide protective, liquid floor-polish products recommended by resilient stair-tread manufacturer.

PART 3 - EXECUTION

3.1 EXAMINATION

- A. Examine substrates, with Installer present, for compliance with requirements for maximum moisture content and other conditions affecting performance of the Work.

1. Verify that finishes of substrates comply with tolerances and other requirements specified in other Sections and that substrates are free of cracks, ridges, depressions, scale, and foreign deposits that might interfere with adhesion of resilient products.

B. Proceed with installation only after unsatisfactory conditions have been corrected.

1. Installation of resilient products indicates acceptance of surfaces and conditions.

3.2 PREPARATION

A. Prepare substrates in accordance with manufacturer's written instructions to ensure adhesion of resilient products.

B. Concrete Substrates for Resilient Stair Accessories: Prepare horizontal surfaces in accordance with ASTM F710.

1. Verify that substrates are dry and free of curing compounds, sealers, and hardeners.
2. Remove substrate coatings and other substances that are incompatible with adhesives and that contain soap, wax, oil, or silicone, using mechanical methods recommended by manufacturer. Do not use solvents.
3. Alkalinity and Adhesion Testing: Perform tests recommended by manufacturer. Proceed with installation only after substrate alkalinity falls within range on pH scale recommended by manufacturer in writing, but not less than 5 or more than 9 pH.
4. Moisture Testing: Perform tests so that each test area does not exceed **200 sq. ft.**, and perform no fewer than three tests in each installation area and with test areas evenly spaced in installation areas.
 - a. Relative Humidity Test: Using in-situ probes, ASTM F2170. Proceed with installation only after substrates have a maximum 75 percent relative humidity level measurement.

C. Fill cracks, holes, and depressions in substrates with trowelable leveling and patching compound; remove bumps and ridges to produce a uniform and smooth substrate.

D. Do not install resilient products until materials are the same temperature as space where they are to be installed.

1. At least 48 hours in advance of installation, move resilient products and installation materials into spaces where they will be installed.

E. Immediately before installation, sweep and vacuum clean substrates to be covered by resilient products.

3.3 INSTALLATION OF RESILIENT BASE

A. Comply with manufacturer's written instructions for installing resilient base.

- B. Apply resilient base to walls, columns, pilasters, casework and cabinets in toe spaces, and other permanent fixtures in rooms and areas where base is required.
- C. Install resilient base in lengths as long as practical without gaps at seams and with tops of adjacent pieces aligned.
- D. Tightly adhere resilient base to substrate throughout length of each piece, with base in continuous contact with horizontal and vertical substrates.
- E. Do not stretch resilient base during installation.
- F. On masonry surfaces or other similar irregular substrates, fill voids along top edge of resilient base with manufacturer's recommended adhesive filler material.
- G. Preformed Corners: Install preformed corners before installing straight pieces.
- H. Job-Formed Corners:
 - 1. Outside Corners: Use straight pieces of maximum lengths possible and form with returns not less than **3 inches** in length.
 - a. Form without producing discoloration (whitening) at bends.
 - 2. Inside Corners: Use straight pieces of maximum lengths possible and form with returns not less than **3 inches** in length.
 - a. Miter or cope corners to minimize open joints.

3.4 INSTALLATION OF RESILIENT STAIR ACCESSORIES

- A. Comply with manufacturer's written instructions for installing resilient accessories.
- B. Resilient Stair Accessories:
 - 1. Use stair-tread-nose filler to fill nosing substrates that do not conform to tread contours.
 - 2. Tightly adhere to substrates throughout length of each piece.
 - 3. For treads installed as separate, equal-length units, install to produce a flush joint between units.
- C. Resilient Molding Accessories: Butt to adjacent materials and tightly adhere to substrates throughout length of each piece. Install reducer strips at edges of floor covering that would otherwise be exposed.

3.5 CLEANING AND PROTECTION

- A. Comply with manufacturer's written instructions for cleaning and protecting resilient products.

- B. Perform the following operations immediately after completing resilient-product installation:
 - 1. Remove adhesive and other blemishes from surfaces.
 - 2. Sweep and vacuum horizontal surfaces thoroughly.
 - 3. Damp-mop horizontal surfaces to remove marks and soil.
- C. Protect resilient products from mars, marks, indentations, and other damage from construction operations and placement of equipment and fixtures during remainder of construction period.
- D. Cover resilient products subject to wear and foot traffic until Substantial Completion.

END OF SECTION 096513

SECTION 096516 - RESILIENT SHEET FLOORING

PART 1 - GENERAL

1.1 SUMMARY

A. Section Includes:

1. Rubber sheet flooring with backing.

B. Related Requirements:

1. Section 096513 "Resilient Base and Accessories" for wall base and accessories installed with resilient sheet flooring.
2. Section 096519 "Resilient Tile and Plank Flooring" for modular resilient flooring.
3. Section 096543 "Linoleum Flooring" for modular and sheet linoleum flooring.

1.2 ACTION SUBMITTALS

A. Product Data: For each type of product.

1. Include manufacturer's written data on physical characteristics, durability, and fade resistance.
2. Include manufacturer's written installation instructions for each type of substrate.

B. Shop Drawings: For each type of resilient flooring type required.

1. Include flooring layouts, locations of seams, edges, columns, doorways, enclosing partitions, built-in furniture, cabinets, and cutouts.
2. Show details of special patterns.

C. Samples: For each resilient flooring product and for each color, texture, and pattern specified, in manufacturer's standard size, but not less than **6-by-9-inch** sections.

D. Welded-Seam Samples: For seamless-installation technique indicated and for each resilient flooring product, color, and pattern required; with seam running lengthwise and in center of **6-by-9-inch** Sample applied to a rigid backing and prepared by Installer for this Project.

E. Product Schedule: For each type of resilient flooring product required. Use same designations indicated on Drawings.

1.3 INFORMATIONAL SUBMITTALS

A. Product Test Reports: For resilient sheet flooring, for tests performed by a qualified testing agency.

- B. Qualification Data: For Installer.

1.4 CLOSEOUT SUBMITTALS

- A. Maintenance Data: For each type of resilient sheet flooring to include:
 1. Methods for maintaining resilient sheet flooring, including cleaning and stain-removal products and procedures and manufacturer's recommended maintenance schedule.
 2. Precautions for cleaning materials and methods that could be detrimental to resilient sheet flooring.

1.5 QUALITY ASSURANCE

- A. Installer Qualifications: An entity that employs installers and supervisors who are competent in techniques required by manufacturer for resilient sheet flooring installation and seaming methods indicated.
 1. Engage an installer who employs workers for this Project who are trained or certified by resilient sheet flooring manufacturer for installation techniques required.

1.6 FIELD CONDITIONS

- A. Environmental Limitations: Do not deliver or install resilient flooring until spaces are enclosed and weathertight, wet-work in spaces is complete and dry, and ambient temperature and humidity conditions are maintained at levels planned for building occupants during the remainder of the construction period.
- B. Do not install resilient flooring over concrete slabs until slabs have cured and are sufficiently dry to bond with adhesive and concrete slabs have pH range recommended in writing by resilient flooring manufacturer.
- C. Adhesively Applied Products:
 1. Maintain temperatures during installation within range recommended in writing by manufacturer, but not less than **70 deg F** or more than **95 deg F**, in spaces to receive flooring 48 hours before installation, during installation, and 48 hours after installation unless longer period is recommended in writing by manufacturer.
 2. After postinstallation period, maintain temperatures within range recommended in writing by manufacturer, but not less than **55 deg F** or more than **95 deg F**.
 3. Close spaces to traffic during flooring installation.
 4. Close spaces to traffic for 48 hours after flooring installation unless manufacturer recommends longer period in writing.

PART 2 - PRODUCTS

2.1 PERFORMANCE REQUIREMENTS

2.2 RESILIENT SHEET FLOORING

- A. Rubber Sheet Flooring with Backing (RB-1): Resilient sheet flooring product with vulcanized rubber wear layer that is colored or patterned and backing.
1. Manufacturers: Subject to compliance with requirements, provide products by the following:
 - a. Nora by Interface
 2. Classification: ASTM F1860, Type I, Homogeneous.
 3. Wear-Layer Thickness: As standard with manufacturer.
 4. Overall Thickness: As standard with manufacturer.
 5. Interlayer Material: As standard with manufacturer.
 6. Backing: Grade 2, Foamed rubber.
 7. Hardness: Manufacturer's standard hardness, measured using Shore, Type A durometer in accordance with ASTM D2240.
 8. Wearing Surface: Smooth.
 9. Sheet Width: As standard with manufacturer.
 10. Seamless Installation Method: Heat welded.
 11. Colors and Patterns: Norament Costello, 5355 Palazzo.
- B. Rubber Sheet Flooring with Backing 2 (RB-2): Resilient sheet flooring product with vulcanized rubber wear layer that is colored or patterned and backing.
1. Manufacturers: Subject to compliance with requirements, provide products by the following:
 - a. Nora by Interface
 2. Classification: ASTM F1860, Type I, Homogeneous.
 3. Wear-Layer Thickness: As standard with manufacturer.
 4. Overall Thickness: As standard with manufacturer.
 5. Interlayer Material: As standard with manufacturer.
 6. Backing: Grade 2, Foamed rubber.
 7. Hardness: Manufacturer's standard hardness, measured using Shore, Type A durometer in accordance with ASTM D2240.
 8. Wearing Surface: Smooth.
 9. Sheet Width: As standard with manufacturer.
 10. Seamless Installation Method: Heat welded.
 11. Colors and Patterns: Norament Costello, 5356 Domus.

2.3 INSTALLATION MATERIALS

- A. Trowelable Leveling and Patching Compounds: Latex-modified, portland-cement-based or blended hydraulic-cement-based formulation provided or approved by

resilient sheet flooring manufacturer for applications indicated.

- B. Adhesives: Water-resistant type recommended in writing by flooring and adhesive manufacturers to suit resilient sheet flooring and substrate conditions indicated.
- C. Seamless Installation Accessories:
 - 1. Heat-Welding Bead: Manufacturer's solid-strand product for heat welding seams.
 - a. Colors: Match flooring.
 - 2. Chemical-Bonding Compound: Manufacturer's product for chemically bonding seams.
- D. Integral-Flash-Cove-Base Accessories:
 - 1. Cove Strip: **1-inch** radius provided or approved by resilient sheet flooring manufacturer.
 - 2. Cap Strip: Square metal, vinyl, or rubber cap provided or approved by resilient sheet flooring manufacturer.
 - 3. Corners: Metal inside and outside corners and end stops provided or approved by resilient sheet flooring manufacturer.
- E. Floor Polish: Provide protective, liquid floor-polish products recommended by resilient sheet flooring manufacturer.

PART 3 - EXECUTION

3.1 INSTALLATION OF RESILIENT SHEET FLOORING

- A. Comply with manufacturer's written installation instructions.
- B. Unroll resilient sheet flooring and allow it to stabilize before cutting and fitting.
- C. Lay out resilient sheet flooring as follows:
 - 1. Maintain uniformity of flooring direction.
 - 2. Minimize number of seams; place seams in inconspicuous and low-traffic areas, at least **6 inches** away from parallel joints in flooring substrates.
 - 3. Match edges of flooring for color shading at seams.
 - 4. Avoid cross seams.
- D. Scribe and cut resilient sheet flooring to butt neatly and tightly to vertical surfaces and permanent fixtures, including built-in furniture, cabinets, pipes, outlets, and door frames.
- E. Extend resilient sheet flooring into toe spaces, door reveals, closets, and similar openings.

- F. Maintain reference markers, holes, and openings that are in place or marked for future cutting by repeating on resilient sheet flooring as marked on substrates. Use chalk or other nonpermanent marking device.
- G. Install resilient sheet flooring on covers for telephone and electrical ducts and similar items in installation areas. Maintain overall continuity of color and pattern between pieces of flooring installed on covers and adjoining flooring. Tightly adhere flooring edges to substrates that abut covers and to cover perimeters.
- H. Adhere resilient sheet flooring to substrates using a full spread of adhesive applied to substrate to produce a completed installation without open cracks, voids, raising and puckering at joints, telegraphing of adhesive spreader marks, and other surface imperfections.
- I. Seamless Installation:
 - 1. Heat-Welded Seams: Comply with ASTM F1516. Rout joints and heat weld with welding bead to fuse sections permanently into a seamless flooring installation. Prepare, weld, and finish seams to produce surfaces flush with adjoining flooring surfaces.
 - 2. Chemically Bonded Seams: Bond seams with chemical-bonding compound to fuse sections permanently into a seamless flooring installation. Prepare seams and apply compound to produce tightly fitted seams without gaps, overlays, or excess bonding compound on flooring surfaces.
- J. Integral-Flash-Cove Base: Cove resilient sheet flooring to dimension indicated up vertical surfaces. Support flooring at horizontal and vertical junction with cove strip. Butt at top against cap strip.
 - 1. Install metal corners at inside and outside corners.

END OF SECTION 096516

SECTION 096519 - RESILIENT TILE AND PLANK FLOORING

PART 1 - GENERAL

1.1 SUMMARY

A. Section Includes:

1. Commercial luxury vinyl floor planks.

B. Related Requirements:

1. Section 024119 "Selective Demolition" for removing existing floor coverings.
2. Section 096513 "Resilient Base and Accessories" for wall base and accessories installed with resilient tile and plank flooring.
3. Section 096516 "Resilient Sheet Flooring" for resilient rolled flooring.
4. Section 096543 "Linoleum Flooring" for modular and sheet linoleum flooring.

1.2 ACTION SUBMITTALS

A. Product Data: For each type of product.

1. Include manufacturers' written data on physical characteristics, durability, and fade resistance.
2. Include manufacturers' written installation instructions for each type of substrate.

B. Shop Drawings: For each type of resilient flooring type required.

1. Include flooring layouts, edges, columns, doorways, enclosing partitions, built-in furniture, cabinets, and cutouts.
2. Show details of special patterns.

C. Samples: Full-size units of each color, texture, and pattern of resilient flooring type required.

D. Samples for Initial Selection: For each type of resilient flooring product required.

E. Samples for Verification: Full-size units of each color and pattern of resilient flooring type required.

F. Product Schedule: For each type of resilient flooring product required.

G. Sustainable Design Submittals:

1. Third-Party Certifications: For each product.
2. Third-Party-Certified Life-Cycle Assessment: For each product.

1.3 INFORMATIONAL SUBMITTALS

- A. Product Test Reports: For resilient flooring, for tests performed by a qualified testing agency.
- B. Qualification Data: For Installer.

1.4 CLOSEOUT SUBMITTALS

- A. Maintenance Data: For each type of resilient flooring product type to include:
 - 1. Methods for maintaining resilient flooring, including cleaning and stain-removal products and procedures and manufacturer's recommended maintenance schedule.
 - 2. Precautions for cleaning materials and methods that could be detrimental to resilient flooring.

1.5 MAINTENANCE MATERIAL SUBMITTALS

- A. Extra Stock Material: Furnish extra materials, from the same production run, to Owner that match products installed and that are packaged with protective covering for storage and identified with labels describing contents.
 - 1. Resilient Tile and Plank Flooring: Furnish no fewer than 1 box for each 50 boxes or fraction thereof, of each type, color, pattern, and size of resilient flooring product installed.

1.6 QUALITY ASSURANCE

- A. Installer Qualifications: An entity that employs installers and supervisors who are competent in techniques required by manufacturer for resilient flooring installation and seaming method indicated.
 - 1. Engage an installer who employs workers for this Project who are trained or certified by resilient flooring manufacturer for installation techniques required.

1.7 FIELD CONDITIONS

- A. Environmental Limitations: Do not deliver or install resilient flooring until spaces are enclosed and weathertight, wet-work in spaces is complete and dry, and ambient temperature and humidity conditions are maintained at levels planned for building occupants during the remainder of the construction period.
- B. Do not install resilient flooring over concrete slabs until slabs have cured and are sufficiently dry to bond with adhesive and concrete slabs have pH range recommended in writing by resilient flooring manufacturer.

C. Adhesively Applied Products:

1. Maintain temperatures during installation within range recommended in writing by manufacturer, but not less than 70 deg F or more than 95 deg F, in spaces to receive flooring 48 hours before installation, during installation, and 48 hours after installation unless longer period is recommended in writing by manufacturer.
2. After postinstallation period, maintain temperatures within range recommended in writing by manufacturer, but not less than 55 deg F or more than 95 deg F.
3. Close spaces to traffic during flooring installation.
4. Close spaces to traffic for 48 hours after flooring installation unless manufacturer recommends longer period in writing.

1.8 WARRANTY

A. Special Warranty for Resilient Flooring Products: Manufacturer agrees to repair or replace components of flooring installation that fail in materials or workmanship within specified warranty period.

1. Warranty does not include deterioration or failure of flooring due to unusual traffic, failure of substrate, vandalism, or abuse.
2. Warranty Period: 10 years from date of Substantial Completion.

PART 2 - PRODUCTS

2.1 PERFORMANCE REQUIREMENTS

2.2 RESILIENT TILE AND PLANK FLOORING

A. Commercial Luxury Vinyl Floor Planks (LVT-1): Solid, resilient plank flooring product composed of binder, fillers, and pigments compounded with suitable stabilizers and processing aids; marketed as luxury vinyl planks (LVP).

1. Manufacturers: Subject to compliance with requirements, provide products by the following:
 - a. Shaw Industries Group, Inc.; Berkshire Hathaway Company
 - b. Interface
2. Classification: ASTM F1700, Class III, Printed Film Vinyl Tile.
 - a. Type: B, Embossed Surface.
3. Overall Thickness: .197 inch including manufacturer's standard clear wear layer and UV-cured polyurethane topcoat.
4. Nominal Size: 9 by 48 inches.
5. Colors and Patterns: See Finish Schedule.

B. Commercial Luxury Vinyl Floor Planks 2 (LVT-2): Solid, resilient plank flooring product composed of binder, fillers, and pigments compounded with suitable stabilizers and

processing aids; marketed as luxury vinyl planks (LVP).

1. Manufacturers: Subject to compliance with requirements, provide products by the following:
 - a. Shaw Industries Group, Inc.; Berkshire Hathaway Company
 2. Classification: ASTM F1700, Class III, Printed Film Vinyl Tile.
 - a. Type: B, Embossed Surface.
 3. Overall Thickness: .197 inch including manufacturer's standard clear wear layer and UV-cured polyurethane topcoat.
 4. Nominal Size: 9 by 48 inches.
 5. Colors and Patterns: See Finish Schedule.
 6. Recycled Content: Provide manufacturer documentation for recycled content, indicating postconsumer and preconsumer recycled content.
- C. Commercial Luxury Vinyl Floor Planks 3 (LVT-3): Solid, resilient plank flooring product composed of binder, fillers, and pigments compounded with suitable stabilizers and processing aids; marketed as luxury vinyl planks (LVP).
1. Manufacturers: Subject to compliance with requirements, provide products by the following:
 - a. Interface
 2. Classification: ASTM F1700, Class III, Printed Film Vinyl Tile.
 - a. Type: B, Embossed Surface.
 3. Overall Thickness: 4.5 mm including manufacturer's standard clear wear layer and UV-cured polyurethane topcoat.
 4. Nominal Size: 9.845 by 39.38 inches.
 5. Colors and Patterns: See Finish Schedule.

2.3 INSTALLATION MATERIALS

- A. Trowelable Leveling and Patching Compounds: Latex-modified, portland-cement-based or blended hydraulic-cement-based formulation provided or approved by flooring manufacturer for applications indicated.
- B. Adhesives: Water-resistant type recommended in writing by floor tile and adhesive manufacturers for substrate and conditions indicated.
- C. Floor Polish: Provide protective, liquid floor-polish products recommended by floor tile manufacturer.

PART 3 - EXECUTION

3.1 EXAMINATION

- A. Examine substrates, areas, and conditions, with Installer present, for compliance with requirements for installation tolerances, moisture content, and other conditions affecting performance of the Work.
 - 1. Verify that finishes of substrates comply with tolerances and other requirements specified in other Sections and that substrates are free of cracks, ridges, depressions, scale, and foreign deposits that might interfere with adhesion of resilient products.
- B. Proceed with installation only after unsatisfactory conditions have been corrected.
 - 1. Installation of resilient flooring products indicates acceptance of surfaces and conditions.

3.2 PREPARATION

- A. Prepare substrates in accordance with manufacturer's written installation instructions to ensure adhesion of flooring.
- B. Concrete Substrates: Prepare in accordance with ASTM F710.
 - 1. Verify that substrates are dry and free of curing compounds, sealers, and hardeners.
 - 2. Remove substrate coatings and other substances that are incompatible with adhesives and that contain soap, wax, oil, or silicone, using mechanical methods recommended by resilient flooring manufacturer. Do not use solvents.
 - 3. Alkalinity Testing: Perform pH testing in accordance with ASTM F710. Proceed with installation only if pH readings are not less than 7.0 and not greater than 8.5.
 - 4. Moisture Testing: Perform tests so that each test area does not exceed **200 sq. ft.** and perform no fewer than three tests in each installation area and with test areas evenly spaced in installation areas.
 - a. Relative Humidity Test: Using in-situ probes, ASTM F2170. Proceed with installation only after substrates have a maximum 75 percent relative humidity level measurement.
- C. Fill cracks, holes, and depressions in substrates with trowelable leveling and patching compound; remove bumps and ridges to produce a uniform and smooth substrate.
- D. Move flooring and installation materials into spaces where they will be installed at least 48 hours in advance of installation unless manufacturer recommends a longer period in writing.
 - 1. Do not install flooring until it is the same temperature as space where it is to be installed.

- E. Sweep and vacuum clean substrates to be covered by flooring immediately before installation. After cleaning, examine substrates for moisture, alkaline salts, carbonation, and dust. Proceed with installation only after unsatisfactory conditions have been corrected.

3.3 INSTALLATION OF RESILIENT TILE AND PLANK FLOORING

- A. Comply with manufacturer's written installation instructions.
- B. Discard broken, cracked, chipped, or deformed tiles.
- C. Lay out floor tiles from center marks established with principal walls, discounting minor offsets, so tiles at opposite edges of room are of equal width. Adjust as necessary to avoid using cut widths that equal less than one-half tile at perimeter.
 - 1. Lay tiles in pattern indicated.
- D. Tile Matching: Match floor tiles for color and pattern by selecting tiles from cartons in the same sequence as manufactured and packaged, if so numbered.
 - 1. Lay tiles in pattern of colors and sizes indicated.
- E. Scribe, cut, and fit floor tiles to butt neatly and tightly to vertical surfaces and permanent fixtures including built-in furniture, cabinets, pipes, outlets, and door frames.
- F. Extend floor tiles into toe spaces, door reveals, closets, and similar openings. Extend floor tiles to center of door openings.
- G. Maintain reference markers, holes, and openings that are in place or marked for future cutting by repeating on floor tiles as marked on substrates. Use chalk or other nonpermanent marking device.
- H. Install floor tiles on covers for telephone and electrical ducts, building expansion-joint covers, and similar items in installation areas. Maintain overall continuity of color and pattern between pieces of tile installed on covers and adjoining tiles. Tightly adhere tile edges to substrates that abut covers and to cover perimeters.
- I. Adhered Floor Tile: Adhere floor tiles to substrates using a full spread of adhesive applied to substrate to comply with adhesive and flooring manufacturers' written installation instructions, including those for trowel notching, adhesive mixing, and adhesive open and working times, to produce a completed installation without open cracks, voids, raising and puckering at joints, telegraphing of adhesive spreader marks, and other surface imperfections.
- J. Floating Floor Tile: Install LVT floor tiles in accordance with flooring manufacturer's written installation instructions.
- K. Seamless Installation: Bond seams with chemical-bonding compound to fuse sections permanently into a seamless flooring installation. Prepare seams and apply compound to produce tightly fitted seams without gaps, overlays, or excess bonding compound on

flooring surfaces.

- L. Resilient Terrazzo Accessories: Install in accordance with manufacturer's written instructions.

3.4 CLEANING AND PROTECTION

- A. Comply with manufacturer's written instructions for cleaning and protecting flooring.

- B. Perform the following operations immediately after completing flooring installation:

1. Remove adhesive and other blemishes from surfaces.
2. Sweep and vacuum surfaces thoroughly.
3. Damp-mop surfaces to remove marks and soil.

- C. Protect flooring from mars, marks, indentations, and other damage from construction operations and placement of equipment and fixtures during remainder of construction period.

- D. Cover resilient flooring until Substantial Completion.

END OF SECTION 096519

SECTION 096543 - LINOLEUM FLOORING

PART 1 - GENERAL

1.1 SUMMARY

A. Section Includes:

1. Linoleum tile flooring.

B. Related Requirements:

1. Section 024119 "Selective Demolition" for removing existing floor coverings.
2. Section 096513 "Resilient Base and Accessories" for wall base and accessories installed with linoleum flooring.
3. Section 096516 "Resilient Sheet Flooring" for resilient rolled flooring.
4. Section 096519 "Resilient Tile and Plank Flooring" for modular resilient flooring.

1.2 ACTION SUBMITTALS

A. Product Data: For each type of product.

1. Include manufacturer's written data on physical characteristics, durability, and fade resistance.
2. Include manufacturer's written installation instructions for each type of substrate.

B. Shop Drawings: For each type of linoleum flooring.

1. Include flooring layouts, locations of seams, edges, columns, doorways, enclosing partitions, built-in furniture, cabinets, and cutouts.
2. Show details of special patterns.

C. Samples: For each exposed product and for each color and pattern specified in manufacturer's standard size, but not less than **6-by-9-inch** sections.

D. Product Schedule: For linoleum flooring. Use same designations indicated on Drawings.

1.3 INFORMATIONAL SUBMITTALS

A. Product Test Reports: For linoleum flooring, for tests performed by a qualified testing agency.

B. Qualification Data: For Installer.

1.4 CLOSEOUT SUBMITTALS

- A. Maintenance Data: For each type of linoleum flooring.

1.5 QUALITY ASSURANCE

- A. Installer Qualifications: An entity that employs installers and supervisors who are competent in techniques required by manufacturer for linoleum flooring installation and seaming methods indicated.

1.6 FIELD CONDITIONS

- A. Maintain ambient temperatures within range recommended by manufacturer, but not less than **70 deg F** or more than **95 deg F**, in spaces to receive flooring during the following periods:
 - 1. 72 hours before installation.
 - 2. During installation.
 - 3. 72 hours after installation.
- B. After installation and until Substantial Completion, maintain ambient temperatures within range recommended by manufacturer, but not less than **55 deg F** or more than **95 deg F**.
- C. Close spaces to traffic during flooring installation.
- D. Close spaces to traffic for 72 hours after flooring installation.
- E. Install flooring after other finishing operations, including painting, have been completed.

PART 2 - PRODUCTS

2.1 PERFORMANCE REQUIREMENTS

2.2 LINOLEUM FLOORING

- A. Linoleum Tile Flooring (RST-1):
 - 1. Basis-of-Design Product: Subject to compliance with requirements, provide Forbo Flooring Systems or comparable product by one of the following:
 - a. Gerflor USA
 - 2. Classification: ASTM F2195, Type I, linoleum floor tile with fibrous backing.
 - 3. Nominal Floor Tile Size: **20 by 20 inches**.
 - 4. Thickness: **0.10 inch**.
 - 5. Colors and Patterns: T3048 Graphite.

2.3 ACCESSORY MATERIALS

- A. Trowelable Leveling and Patching Compounds: Latex-modified, portland-cement-based or blended hydraulic-cement-based formulation provided or approved by flooring manufacturer for applications indicated.
- B. Adhesives: Water-resistant type recommended by flooring and adhesive manufacturers to suit products and substrate conditions indicated.
- C. Floor Polish: Provide protective, liquid floor-polish products recommended by flooring manufacturer.

PART 3 - EXECUTION

3.1 INSTALLATION OF LINOLEUM FLOORING, GENERAL

- A. Comply with manufacturer's written instructions for installing linoleum flooring.
- B. Scribe and cut linoleum flooring to butt neatly and tightly to vertical surfaces and permanent fixtures, including built-in furniture, cabinets, pipes, outlets, edgings, thresholds, door frames, and nosings.
- C. Extend flooring into toe spaces, door reveals, closets, and similar openings.
- D. Maintain reference markers, holes, and openings that are in place or marked for future cutting by repeating on linoleum flooring as marked on substrates. Use chalk or other nonpermanent marking device.
- E. Install linoleum flooring on covers for telephone and electrical ducts and similar items in installation areas. Maintain overall continuity of color and pattern between pieces of flooring installed on covers and adjoining flooring. Tightly adhere flooring edges to substrates that abut covers and to cover perimeters.
- F. Adhere linoleum flooring to substrates using a full spread of adhesive applied to substrate to produce a completed installation without open cracks, voids, raising and puckering at joints, telegraphing of adhesive spreader marks, and other surface imperfections.
- G. Heat-Welded Seams: For seamless installation, comply with ASTM F1516. Rout joints and heat weld with welding bead to fuse sections permanently into a seamless flooring installation. Prepare, weld, and finish seams to produce surfaces flush with adjoining flooring surfaces.

3.2 INSTALLATION OF LINOLEUM TILE FLOORING

- A. Lay out linoleum tile flooring from center marks established with principal walls, discounting minor offsets, so floor tiles at opposite edges of room are of equal width. Adjust as necessary to avoid using cut widths that equal less than one-half tile at

perimeter.

1. Lay floor tiles square with room axis.
- B. Match linoleum floor tiles for color and pattern by selecting tiles from cartons in same sequence as manufactured and packaged, if so numbered. Discard broken, cracked, chipped, or deformed floor tiles.
1. Lay floor tiles in pattern of colors and sizes indicated.

END OF SECTION 096543

SECTION 096566 - RESILIENT ATHLETIC FLOORING

PART 1 - GENERAL

1.1 SUMMARY

- A. Section Includes:
 - 1. Resilient athletic tile flooring.
 - 2. Resilient athletic sheet flooring.
- B. Related Requirements:

1.2 ACTION SUBMITTALS

- A. Product Data: For each type of product.
 - 1. Include manufacturer's written data on physical characteristics, durability, and fade resistance.
 - 2. Include manufacturer's written installation instructions for each type of substrate.
- B. Shop Drawings: Show installation details and locations of the following:
 - 1. Border tiles.
 - 2. Floor patterns.
 - 3. Layout, colors, widths, and dimensions of game lines and markers.
 - 4. Locations of floor inserts for athletic equipment installed through flooring.
 - 5. Locations of junction boxes for fitness equipment installed through flooring.
 - 6. Seam locations for resilient athletic sheet flooring.
- C. Samples: For each exposed product and for each type, color, and pattern specified, **6-inch-**square in size and of the same thickness indicated for the Work.
- D. Product Schedule: For resilient athletic flooring. Use same designations indicated on Drawings.

1.3 INFORMATIONAL SUBMITTALS

- A. Product Test Reports: For resilient athletic flooring, for tests performed by a qualified testing agency.
- B. Qualification Statements: For Installer.

1.4 CLOSEOUT SUBMITTALS

- A. Maintenance Data: For resilient athletic flooring.
 - 1. Methods for maintaining resilient athletic flooring, including cleaning and stain-removal products and procedures and manufacturer's recommended maintenance schedule.
 - 2. Precautions for cleaning materials and methods that could be detrimental to resilient athletic flooring.

1.5 QUALITY ASSURANCE

- A. Resilient Athletic Sheet Flooring Installer Qualifications: An experienced installer who has completed resilient athletic sheet flooring installations using seaming methods indicated for this Project and similar in material, design, and extent to that indicated for this Project; who is acceptable to manufacturer; and whose work has resulted in installations with a record of successful in-service performance.

1.6 FIELD CONDITIONS

- A. Environmental Limitations: Do not deliver or install resilient athletic flooring until spaces are enclosed and weathertight, wet-work in spaces is complete and dry, and ambient temperature and humidity conditions are maintained at levels planned for building occupants during the remainder of the construction period.
- B. Adhesively Applied Products:
 - 1. Maintain temperatures during installation within range recommended in writing by manufacturer, but not less than **70 deg F** or more than **95 deg F**, in spaces to receive flooring 48 hours before installation, during installation, and 48 hours after installation unless longer period is recommended in writing by manufacturer.
 - 2. After postinstallation period, maintain temperatures within range recommended in writing by manufacturer, but not less than **55 deg F** or more than **95 deg F**.
 - 3. Close spaces to traffic during flooring installation.
 - 4. Close spaces to traffic for 48 hours after flooring installation unless manufacturer recommends longer period in writing.

PART 2 - PRODUCTS

2.1 PERFORMANCE REQUIREMENTS

2.2 RESILIENT ATHLETIC TILE FLOORING

- A. Rubber Floor Tile (RST-3): Resilient athletic flooring consisting of modular rubber tiles with smooth square edges for adhered application.
 - 1. Basis-of-Design Product: Subject to compliance with requirements, provide Johnsonite; Intertia Speckled - Square Edge 3/8" or Approved Equivalent by one

of the following:

- a. Aacer Sports Flooring, an Infinity Wood Floors Company
 - b. Action Floor Systems, LLC
 - c. Amarco Products
 - d. American Floor Products Company, Inc
 - e. Connor Sports
 - f. Dinoflex
 - g. Flexco Corporation
 - h. Horner Sports Flooring
 - i. Mateflex
 - j. Matter Surfaces
 - k. Mondo
 - l. Nora by Interface
 - m. REGUPOL AMERICA, LLC
 - n. Robbins Sports Surfaces
 - o. Roppe Corporation; Roppe Holding Company
 - p. Sport Court, a Gerflor Company
 - q. Tarkett Sports; a division of the Tarkett Group
 - r. The R.C. Musson Rubber Co.
 - s. van Gelder, Inc
2. Material: Rubber.
 3. Traffic-Surface Texture: Smooth.
 4. Size: 24 inches square.
 5. Thickness: 3/8 inch.
 6. Weight: Not less than 13.3 per tile.
 7. Color and Pattern: Quinn xC9.
 8. Border: Interlocking, beveled-edge tiles, of same material as floor tile; with bevels that transition from thickness of floor tile to surface below it; with straight outside edges; for use where flooring corners and edges do not abut vertical surfaces.
 - a. Border Color and Pattern: Matching floor tile.

2.3 RESILIENT ATHLETIC SHEET FLOORING

- A. Rubber Sheet Flooring (RST-2): Rubber athletic flooring provided as rolled goods for adhered installation.
 1. Basis-of-Design Product: Subject to compliance with requirements, provide Johnsonite; Replay Commotion Flooring or Approved Equivalent by one of the following:
 - a. Aacer Sports Flooring, an Infinity Wood Floors Company
 - b. Action Floor Systems, LLC
 - c. Amarco Products
 - d. American Floor Products Company, Inc
 - e. Connor Sports
 - f. Flexco Corporation

- g. Horner Sports Flooring
 - h. Mondo
 - i. Nora by Interface
 - j. REGUPOL AMERICA, LLC
 - k. Robbins Sports Surfaces
 - l. Roppe Corporation; Roppe Holding Company
 - m. Sport Court, a Gerflor Company
 - n. Surface America, Inc.
 - o. Tarkett Sports; a division of the Tarkett Group
 - p. van Gelder, Inc
- 2. Material: Rubber wear layer and rubber shock-absorbent layer, vulcanized together.
 - 3. Traffic-Surface Texture: Smooth.
 - 4. Roll Size: Not less than **48 inches** wide by longest length that is practical to minimize splicing during installation.
 - 5. Thickness: **3/8 inch**.
 - 6. Color and Pattern: Bluestone RA5.
 - 7. Border: Interlocking, beveled-edge tiles, of same material as sheet flooring; with bevels that transition from thickness of sheet flooring to surface below it; with straight outside edges; for use where flooring corners and edges do not abut vertical surfaces.
 - a. Border Color and Pattern: Matching sheet flooring.

2.4 ACCESSORIES

- A. Trowelable Leveling and Patching Compound: Latex-modified, hydraulic-cement-based formulation approved by flooring manufacturer.
- B. Adhesives: Water-resistant type recommended in writing by manufacturer for substrate and conditions indicated.

PART 3 - EXECUTION

3.1 PREPARATION

- A. Prepare substrates in accordance with manufacturer's written installation instructions to ensure adhesion of flooring.
- B. Concrete Substrates: Prepare in accordance with ASTM F710.
 - 1. Verify that substrates are dry and free of curing compounds, sealers, and hardeners.
 - 2. Alkalinity Testing: Perform pH testing in accordance with ASTM F710. Proceed with installation only if pH readings are not less than 7.0 and not greater than 8.5.
 - 3. Moisture Testing: Perform tests so that each test area does not exceed **200 sq. ft.** and perform no fewer than three tests in each installation area and

with test areas evenly spaced in installation areas.

- a. Relative Humidity Test: Using in-situ probes, ASTM F2170. Proceed with installation only after substrates have a maximum 75 percent relative humidity level measurement.
- C. Remove substrate coatings and other substances that are incompatible with adhesives and that contain soap, wax, oil, or silicone, using mechanical methods recommended in writing by manufacturer. Do not use solvents.
- D. Use trowelable leveling and patching compound to fill cracks, holes, and depressions in substrates.
- E. Move flooring and installation materials into spaces where they will be installed at least 48 hours in advance of installation unless manufacturer recommends a longer period in writing.
 1. Do not install flooring until it is the same temperature as space where it is to be installed.
- F. Sweep and vacuum clean substrates to be covered by flooring immediately before installation. After cleaning, examine substrates for moisture, alkaline salts, carbonation, and dust. Proceed with installation only after unsatisfactory conditions have been corrected.

3.2 INSTALLATION OF RESILIENT ATHLETIC FLOORING, GENERAL

- A. Comply with manufacturer's written installation instructions.
- B. Scribe, cut, and fit flooring to butt neatly and tightly to vertical surfaces, equipment anchors, floor outlets, and other interruptions of floor surface.
- C. Extend flooring into toe spaces, door reveals, closets, and similar openings unless otherwise indicated.
- D. Maintain reference markers, holes, and openings that are in place or marked for future cutting by repeating subfloor markings on flooring. Use nonpermanent, nonstaining marking device.

3.3 INSTALLATION OF RESILIENT ATHLETIC TILE FLOORING

- A. Lay out tiles from center marks established with principal walls, discounting minor offsets, so tiles at opposite edges of room are of equal width. Adjust as necessary to avoid using cut widths that equal less than one-half tile at perimeter.
 1. Lay tiles in pattern indicated.
- B. Discard broken, cracked, chipped, or deformed tiles.

- C. Tile Matching: Match tiles for color and pattern by selecting tiles from cartons in same sequence as manufactured and packaged if so numbered.
 - 1. Lay tiles in pattern of colors and sizes indicated.
- D. Adhered Floor Tile: Adhere products to substrates using a full spread of adhesive applied to substrate to comply with adhesive and flooring manufacturers' written installation instructions, including those for trowel notching, adhesive mixing, and adhesive open and working times.
 - 1. Provide completed installation without open cracks, voids, raising and puckering at joints, telegraphing of adhesive spreader marks, and other surface imperfections.
- E. Free-Lay Tile: Place flooring at locations indicated with units securely interconnected and fully seated on substrate to form a smooth, level surface.

3.4 INSTALLATION OF RESILIENT ATHLETIC SHEET FLOORING

- A. Unroll sheet flooring and allow it to stabilize before cutting and fitting.
- B. Lay out sheet flooring as follows:
 - 1. Maintain uniformity of flooring direction.
 - 2. Minimize number of seams; place seams in inconspicuous and low-traffic areas, at least **6 inches** away from parallel joints in flooring substrates.
 - 3. Match edges of flooring for color shading at seams.
 - 4. Locate seams in accordance with approved Shop Drawings.
- C. Adhere products to substrates using a full spread of adhesive applied to substrate to comply with adhesive and flooring manufacturers' written installation instructions, including those for trowel notching, adhesive mixing, and adhesive open and working times.
 - 1. Provide completed installation without open cracks, voids, raising and puckering at joints, telegraphing of adhesive spreader marks, and other surface imperfections.

3.5 CLEANING AND PROTECTION

- A. Perform the following operations immediately after completing flooring installation:
 - 1. Remove adhesive and other blemishes from flooring surfaces.
 - 2. Sweep and vacuum flooring thoroughly.
 - 3. Damp-mop flooring to remove marks and soil after time period recommended in writing by manufacturer.

END OF SECTION 096566

SECTION 096813 - TILE CARPETING

PART 1 - GENERAL

1.1 SUMMARY

A. Section Includes:

1. Carpet tile.

B. Related Requirements:

1. Section 024119 "Selective Demolition" for removing existing floor coverings.
2. Section 096513 "Resilient Base and Accessories" for resilient wall base and accessories installed with carpet tile.

1.2 PREINSTALLATION MEETINGS

A. Preinstallation Conference: Conduct conference at Project site.

1. Review methods and procedures related to carpet tile installation including, but not limited to, the following:
 - a. Review delivery, storage, and handling procedures.
 - b. Review ambient conditions and ventilation procedures.
 - c. Review subfloor preparation procedures.
 - d. Review existing conditions..

1.3 ACTION SUBMITTALS

A. Product Data: For each type of product.

1. Include manufacturer's written data on physical characteristics, durability, and fade resistance.
2. Include manufacturer's written installation recommendations for each type of substrate.

B. Shop Drawings: For carpet tile installation, showing the following:

1. Columns, doorways, enclosing walls or partitions, built-in cabinets, and locations where cutouts are required in carpet tiles.
2. Carpet tile type, color, and dye lot.
3. Type of subfloor.
4. Type of installation.
5. Pattern of installation.
6. Pattern type, location, and direction.

7. Transition details to other flooring materials.

C. Samples for Verification: Actual sample of finished products for each of the following products and for each color and texture required. Label each Sample with manufacturer's name, material description, color, pattern, and designation indicated on Drawings and in schedules.

1. Carpet Tile: Full-size Sample.
2. Exposed Edge, Transition, and Other Accessory Stripping: **12-inch-** long Samples.

D. Product Schedule: For carpet tile. Use same designations indicated on Drawings.

1.4 INFORMATIONAL SUBMITTALS

A. Sample Warranties: For carpet tile.

1.5 CLOSEOUT SUBMITTALS

A. Maintenance Data: For carpet tiles. Include the following:

1. Methods for maintaining carpet tile, including cleaning and stain-removal products and procedures and manufacturer's recommended maintenance schedule.
2. Precautions for cleaning materials and methods that could be detrimental to carpet tile.

1.6 MAINTENANCE MATERIAL SUBMITTALS

A. Extra Stock Material: Furnish extra materials, from the same production run, to Owner that match products installed and that are packaged with protective covering for storage and identified with labels describing contents.

1. Carpet Tile: Full-size units equal to 5 percent of amount installed for each type indicated, but no fewer than 10 full-size units.

1.7 QUALITY ASSURANCE

A. Installer Qualifications: An authorized representative who is certified by the International Certified Floorcovering Installers Association at the Commercial II Master II certification level or as required by the manufacturer.

1.8 DELIVERY, STORAGE, AND HANDLING

A. Comply with CRI 104.

1.9 FIELD CONDITIONS

- A. Comply with CRI 104 for temperature, humidity, and ventilation limitations.
- B. Environmental Limitations: Do not deliver or install carpet tiles until spaces are enclosed and weathertight, wet-work in spaces is complete and dry, and ambient temperature and humidity conditions are maintained at levels planned for building occupants during the remainder of the construction period.
- C. Do not install carpet tiles over concrete slabs until slabs have cured and are sufficiently dry to bond with adhesive and concrete slabs have pH range recommended in writing by carpet tile manufacturer.
- D. Where demountable partitions or other items are indicated for installation on top of carpet tiles, install carpet tiles before installing these items.

1.10 WARRANTY

- A. Special Warranty for Carpet Tiles: Manufacturer agrees to repair or replace components of carpet tile installation that fail in materials or workmanship within specified warranty period.
 - 1. Warranty does not include deterioration or failure of carpet tile due to unusual traffic, failure of substrate, vandalism, or abuse.
 - 2. Failures include, but are not limited to, the following:
 - a. More than 10 percent loss of face fiber, edge raveling, snags, and runs.
 - b. Loss of tuft-bind strength.
 - c. Excess static discharge.
 - d. Delamination.
 - e. Dimensional instability.
 - 3. Warranty Period: Lifetime Commercial Limited Warranty from date of Substantial Completion.

PART 2 - PRODUCTS

2.1 CARPET TILE (CPT-1, CPT-2)

- A. Basis-of-Design Product: Subject to compliance with requirements, provide Shaw Industries Group, Inc. or Approved Equivalent by one of the following:
 - 1. Bentley Mills, Inc.
 - 2. Engineered Floors
 - 3. Interface, Inc.
 - 4. J&J Flooring Group LLC
 - 5. Mannington Commercial; a business unit of Mannington Mills, Inc.
 - 6. Mohawk Group

7. StaticSmart; Julie Industries
 8. Tarkett USA
 9. van Gelder, Inc
- B. Color: Per Schedule.
- C. Pattern: See Drawings.
- D. Style: Path Tile 5T034
- E. Fiber Content: 100 percent nylon 6.
- F. Fiber Type: Ecosolution Q100 Nylon.
- G. Pile Characteristic: Level-loop pile.
- H. Density: **8765 oz./cu. yd.**
- I. Pile Thickness: .161 inches for finished carpet tile in accordance with ASTM D6859.
- J. Stitches: **8.5 per inc.**
- K. Gage: **Insert ends per inch.**
- L. Surface Pile Weight: **28 oz./sq. yd.**
- M. Primary Backing/Backcoating: Manufacturer's standard composite materials.
- N. Secondary Backing: Manufacturer's standard material.
- O. Backing System: Ecoworx Tile.
- P. Size: **24 by 24 inches.**
- Q. Applied Treatments:
1. Soil-Resistance Treatment: Manufacturer's standard treatment.
- R. Sustainable Design Requirements:
1. Sustainable Product Certification: Gold level certification in accordance with NSF/ANSI 140.
- S. Performance Characteristics:
1. Texture Appearance Retention Rating (TARR): Severe traffic, 3.5 minimum in accordance with ASTM D7330.
 2. Critical Radiant Flux Classification: Not less than 0.45 W/sq. cm in accordance with NFPA 253.
 3. Dry Breaking Strength: Not less than **100 lbf** in accordance with ASTM D2646.
 4. Tuft Bind: Not less than **8 lbf** in accordance with ASTM D1335.

5. Delamination: Not less than **3.5 lbf/in.** in accordance with ASTM D3936.
6. Dimensional Tolerance: Within **1/32 inch** of specified size dimensions, as determined by physical measurement.
7. Noise Reduction Coefficient (NRC): N/A Number in accordance with ASTM C423.
8. Colorfastness to Crocking: Not less than 4, wet and dry, in accordance with AATCC 165.
9. Colorfastness to Light: Not less than 5 after 60 AFU (AATCC fading units) in accordance with AATCC 16.3 Option 3.
10. Electrostatic Propensity: Less than 2.5 kV in accordance with AATCC 134.

2.2 CARPET TILE 3 (CPT-3)

- A. Manufacturers: Subject to compliance with requirements, provide products by the following:
 1. Mohawk Group
- B. Color: Per Finish Schedule.

2.3 CARPET TILE 4 (CPT-4)

- A. Manufacturers: Subject to compliance with requirements, provide products by the following:
 1. Interface, Inc.
- B. Color: Per Finish Schedule.

2.4 CARPET TILE 5 (CPT-5)

- A. Manufacturers: Subject to compliance with requirements, provide products by the following:
 1. Shaw Industries Group, Inc.; Berkshire Hathaway Company
- B. Color: Per Finish Schedule.

2.5 CARPET TILE 6 (CPT-6)

- A. Manufacturers: Subject to compliance with requirements, provide products by the following:
 1. Interface, Inc.
- B. Color: Per Finish Schedule.

2.6 CARPET TILE 7 (CPT-7)

- A. Manufacturers: Subject to compliance with requirements, provide products by the following:
 - 1. Patcraft
- B. Color: Per Finish Schedule.

2.7 CARPET TILE 8 (CPT-8)

- A. Manufacturers: Subject to compliance with requirements, provide products by the following:
 - 1. Shaw Industries Group, Inc.; Berkshire Hathaway Company
- B. Color: See Finish Schedule.

2.8 CARPET TILE 9 (CPT-9)

- A. Manufacturers: Subject to compliance with requirements, provide products by the following:
 - 1. Shaw Industries Group, Inc.; Berkshire Hathaway Company
- B. Color: Per Finish Schedule.

2.9 CARPET TILE 10 (CPT-10)

- A. Manufacturers: Subject to compliance with requirements, provide products by the following:
 - 1. Shaw Contract; Zest Tile 5T487
- B. Color: Brio 87518.

2.10 CARPET TILE 11 (CPT-11)

- A. Manufacturers: Subject to compliance with requirements, provide products by the following:
 - 1. Interface, Inc.
- B. Color: 108327 Mist.
- C. Style: Open Air 441.

2.11 CARPET TILE 12 (CPT-12)

- A. Manufacturers: Subject to compliance with requirements, provide products by the following:
 - 1. Mohawk Group
- B. Color: 585 Bottom of a Well.
- C. Style: Wild Dyer - Curious Cluster GT353.

2.12 CARPET TILE 13 (CPT-13)

- A. Manufacturers: Subject to compliance with requirements, provide products by the following:
 - 1. Shaw Industries Group, Inc.; Berkshire Hathaway Company
- B. Color: Ivy 35375.
- C. Style: Honest Tile 5T236.

2.13 CARPET TILE 14 (CPT-14)

- A. Manufacturers: Subject to compliance with requirements, provide products by the following:
 - 1. Mohawk Group
- B. Color: 555 Indigo Milk Cap.
- C. Style: Above and Below - Biotape GT357.

2.14 CARPET TILE 15 (CPT-15)

- A. Manufacturers: Subject to compliance with requirements, provide products by the following:
 - 1. Interface, Inc.
- B. Color: Midnight/Pearl.
- C. Style: Squared Away:21-1589.

2.15 CARPET TILE 16 (CPT-16)

- A. Manufacturers: Subject to compliance with requirements, provide products by the

following:

1. Interface, Inc.
- B. Color: 107795 Mist.
- C. Style: Open Air 418.

2.16 INSTALLATION ACCESSORIES

- A. Trowelable Leveling and Patching Compounds: Latex-modified, hydraulic-cement-based formulation provided or recommended in writing by carpet tile manufacturer.
- B. Adhesives: Water-resistant, mildew-resistant, nonstaining, pressure-sensitive types to suit products and subfloor conditions indicated, that comply with flammability requirements for installed carpet tile, and that are recommended in writing by carpet tile manufacturer for releasable installation.
- C. Metal Edge/Transition Strips: Extruded aluminum with mill finish of profile and width shown, of height required to protect exposed edge of carpet, and of maximum lengths to minimize running joints.

PART 3 - EXECUTION

3.1 EXAMINATION

- A. Examine substrates, areas, and conditions, with Installer present, for compliance with requirements for maximum moisture content, alkalinity range, installation tolerances, and other conditions affecting carpet tile performance.
- B. Examine carpet tile for type, color, pattern, and potential defects.
- C. Concrete Slabs: Verify that finishes comply with requirements specified in Section 033000 "Cast-in-Place Concrete" and that surfaces are free of cracks, ridges, depressions, scale, and foreign deposits.
 1. Moisture Testing: Perform tests so that each test area does not exceed **200 sq. ft.**, and perform no fewer than three tests in each installation area and with test areas evenly spaced in installation areas.
 - a. Relative Humidity Test: Using in situ probes, ASTM F2170. Proceed with installation only after substrates have a maximum 75 percent relative humidity level measurement.
 - b. Perform additional moisture tests recommended in writing by adhesive and carpet tile manufacturers. Proceed with installation only after substrates pass testing.
- D. Wood Subfloors: Verify the following:

1. Underlayment over subfloor complies with requirements specified in Section 061600 "Sheathing."
 2. Underlayment surface is free of irregularities and substances that may interfere with adhesive bond or show through surface.
- E. Metal Subfloors: Verify the following:
1. Underlayment surface is free of irregularities and substances that may interfere with adhesive bond or show through surface.
- F. Painted Subfloors: Perform bond test recommended in writing by adhesive manufacturer. Verify the following:
1. Underlayment surface is flat, smooth, evenly planed, tightly jointed, and free of irregularities, gaps greater than **1/8 inch**, protrusions more than **1/32 inch**, and substances that may interfere with adhesive bond or show through surface.
- G. Access Flooring Systems: Verify the following:
- H. Proceed with installation only after unsatisfactory conditions have been corrected.

3.2 PREPARATION

- A. General: Comply with CRI 104 and with carpet tile manufacturer's written installation instructions for preparing substrates.
- B. Use trowelable leveling and patching compounds, in accordance with manufacturer's written instructions, to fill cracks, holes, depressions, and protrusions in substrates. Fill or level cracks, holes and depressions **1/8 inch** wide or wider, and protrusions more than **1/32 inch** unless more stringent requirements are required by manufacturer's written instructions.
- C. Concrete Substrates: Remove coatings, including curing compounds, and other substances that are incompatible with adhesives and that contain soap, wax, oil, or silicone, without using solvents. Use mechanical methods recommended in writing by adhesive and carpet tile manufacturers.
- D. Metal Substrates: Clean grease, oil, soil and rust, and prime if recommended in writing by adhesive manufacturer. Rough sand painted metal surfaces and remove loose paint. Sand aluminum surfaces, to remove metal oxides, immediately before applying adhesive.
- E. Broom and vacuum clean substrates to be covered immediately before installing carpet tile.

3.3 INSTALLATION

- A. General: Comply with CRI 104, Section 10, "Carpet Tile," and with carpet tile manufacturer's written installation instructions.

- B. Installation Method: Glue down; install every tile with full-spread, releasable, pressure-sensitive adhesive.
- C. Maintain dye-lot integrity. Do not mix dye lots in same area.
- D. Maintain pile-direction patterns indicated on Drawings.
- E. Cut and fit carpet tile to butt tightly to vertical surfaces, permanent fixtures, and built-in furniture including cabinets, pipes, outlets, edgings, thresholds, and nosings. Bind or seal cut edges as recommended in writing by carpet tile manufacturer.
- F. Extend carpet tile into toe spaces, door reveals, closets, open-bottomed obstructions, removable flanges, alcoves, and similar openings.
- G. Maintain reference markers, holes, and openings that are in place or marked for future cutting by repeating on carpet tile as marked on subfloor. Use nonpermanent, nonstaining marking device.
- H. Install pattern parallel to walls and borders.

3.4 CLEANING AND PROTECTION

- A. Perform the following operations immediately after installing carpet tile:
 - 1. Remove excess adhesive and other surface blemishes using cleaner recommended in writing by carpet tile manufacturer.
 - 2. Remove yarns that protrude from carpet tile surface.
 - 3. Vacuum carpet tile using commercial machine with face-beater element.
- B. Protect installed carpet tile to comply with CRI 104, Section 13.7 or per manufacturer instructions.
- C. Protect carpet tile against damage from construction operations and placement of equipment and fixtures during the remainder of construction period. Use protection methods indicated or recommended in writing by carpet tile manufacturer.

END OF SECTION 096813

SECTION 097200 - WALL COVERINGS

PART 1 - GENERAL

1.1 SUMMARY

A. Section Includes:

1. Vinyl wall covering.

1.2 ACTION SUBMITTALS

A. Product Data: For each type of product.

1. Include data on physical characteristics, durability, fade resistance, and fire-test-response characteristics.

B. Shop Drawings: Show location and extent of each wall-covering type. Indicate pattern placement seams and termination points.

C. Samples: For each type of wall covering and for each color, pattern, texture, and finish specified, full width by **36 inches** long in size.

1.3 INFORMATIONAL SUBMITTALS

A. Product Test Reports: For each wall covering, for tests performed by a qualified testing agency.

1.4 CLOSEOUT SUBMITTALS

A. Maintenance Data: For wall coverings to include in maintenance manuals.

1.5 QUALITY ASSURANCE

1.6 FIELD CONDITIONS

A. Environmental Limitations: Do not deliver or install wall coverings until spaces are enclosed and weathertight, wet-work in spaces is complete and dry, work above ceilings is complete, and HVAC system is operating and maintaining ambient temperature and humidity conditions at levels intended for occupants after Project completion during the remainder of the construction period.

1. Wood-Veneer Wall Coverings: Condition spaces for not less than 48 hours before installation.

- B. Lighting: Do not install wall covering until lighting that matches conditions intended for occupants after Project completion is provided on the surfaces to receive wall covering.
- C. Ventilation: Provide continuous ventilation during installation and for not less than the time recommended by wall-covering manufacturer for full drying or curing.

PART 2 - PRODUCTS

2.1 PERFORMANCE REQUIREMENTS

2.2 VINYL WALL COVERING (WC-1)

- A. Manufacturers: Subject to compliance with requirements, provide products by the following:
 - 1. Momentum
- B. Description: Provide vinyl products in rolls from same production run and complying with the following:
 - 1. Wallcovering Association's W-101 for Type II, Medium Duty.
- C. Total Weight: 20 oz., excluding coatings.
- D. Width: 54 inches.
- E. Backing: Nonwoven fabric.
 - 1. Fiber Content: 50% post-consumer recycled content.
- F. Repeat: 12 5/8" V.
- G. Features:
 - 1. Water-based inks.
 - 2. Phthalate free.
 - 3. Microvented.
- H. Colors, Textures, and Patterns: Fracture SG3000 Diamond.

2.3 ACCESSORIES

- A. Adhesive: Mildew-resistant, nonstaining, strippable adhesive, for use with specific wall covering and substrate application indicated and as recommended in writing by wall-covering manufacturer.
- B. Primer/Sealer: Mildew resistant, complying with requirements in Section 099123 "Interior Painting" and recommended in writing by primer/sealer and wall-covering manufacturers for intended substrate.

- C. Seam Tape: As recommended in writing by wall-covering manufacturer.

PART 3 - EXECUTION

3.1 EXAMINATION

- A. Examine substrates and conditions, with Installer present, for compliance with requirements for installation surfaces being true in plane and vertical and horizontal alignment, maximum moisture content, and other conditions affecting performance of the Work.
- B. Proceed with installation only after unsatisfactory conditions have been corrected.

3.2 PREPARATION

- A. Comply with manufacturer's written instructions for surface preparation.
- B. Clean substrates of substances that could impair bond of wall covering, including dirt, oil, grease, mold, and mildew.
- C. Prepare substrates to achieve a smooth, dry, clean, structurally sound surface free of flaking, unsound coatings, cracks, and defects.
 - 1. Gypsum Board: Apply primer/sealer as recommended in writing by primer/sealer manufacturer and wall-covering manufacturer.
 - 2. Painted Surfaces:
 - a. Check for pigment bleeding. Apply primer/sealer to areas susceptible to pigment bleeding as recommended in writing by primer/sealer manufacturer.
 - b. Sand gloss, semigloss, and eggshell finishes with fine sandpaper.
- D. Remove hardware and hardware accessories, electrical plates and covers, light fixture trims, and similar items.
- E. Acclimatize wall-covering materials by removing them from packaging in the installation areas not less than 24 hours before installation.

3.3 INSTALLATION OF WALL COVERING

- A. Comply with wall-covering manufacturers' written installation instructions applicable to products and applications indicated.
- B. Cut wall-covering strips in roll number sequence. Change the roll numbers at partition breaks and corners.
- C. Install strips in same order as cut from roll.

1. Non-reverse hang, drop match.
- D. Install wall covering without lifted or curling edges and without visible shrinkage.
- E. Match pattern with Repeat at 12-5/8" V.
- F. Install seams vertical and plumb at least **6 inches** from outside corners and **3 inches** from inside corners unless a change of pattern or color exists at corner. Horizontal seams are not permitted.
- G. Trim edges and seams for color uniformity, pattern match, and tight closure. Butt seams without overlaps or gaps between strips.
- H. Fully bond wall covering to substrate. Remove air bubbles, wrinkles, blisters, and other defects.

3.4 CLEANING

- A. Remove excess adhesive at seams, perimeter edges, and adjacent surfaces.
- B. Use cleaning methods recommended in writing by wall-covering manufacturer.
- C. Replace strips that cannot be cleaned.
- D. Reinstall hardware and hardware accessories, electrical plates and covers, light fixture trims, and similar items.

END OF SECTION 097200

SECTION 099113 - EXTERIOR PAINTING

PART 1 - GENERAL

1.1 SUMMARY

- A. Section Includes: Surface preparation of exterior substrates and application of the following:
 - 1. Primers.
 - 2. Water-based finish coatings.
 - 3. Solvent-based finish coatings.
 - 4. Floor sealers and paints.

- B. Related Requirements:
 - 1. Section 051200 "Structural Steel Framing" for shop priming structural steel substrates.
 - 2. Section 099123 "Interior Painting."
 - 3. Section 099300 "Staining and Transparent Finishing" for surface preparation and application of wood stains and transparent finishes on exterior wood substrates.

1.2 ACTION SUBMITTALS

- A. Product Data: For each type of product.
 - 1. Include preparation requirements and application instructions.
 - 2. Indicate VOC content.

- B. Samples: For each type of topcoat product.

- C. Sustainable Design Submittals:

1.3 FIELD CONDITIONS

- A. Apply paints only when temperature of surfaces to be painted and ambient air temperatures are between **50 and 95 deg F**.

- B. Do not apply paints in snow, rain, fog, or mist; when relative humidity exceeds 85 percent; at temperatures less than **5 deg F** above the dew point; or to damp or wet surfaces.

PART 2 - PRODUCTS

2.1 EXTERIOR PAINTS, GENERAL

- A. Exterior Paints: Subject to compliance with requirements, provide product listed in product types below and applicable exterior painting schedule articles for the paint category indicated.
- B. Material Compatibility:
 - 1. Materials for use within each paint system must be compatible with one another and substrates indicated, under conditions of service and application as demonstrated by manufacturer based on testing and field experience.
 - 2. For each coat in a paint system, provide products recommended in writing by topcoat manufacturer for use in paint system and on substrate indicated.
- C. Colors: As indicated in a color schedule on Drawings.

2.2 PRIMERS

- A. Water-Based, Galvanized-Metal Primer: Corrosion-resistant, pigmented, acrylic primer; formulated for use on cleaned/etched galvanized metal substrates to prepare it for subsequent water-based coatings.
 - 1. Basis-of-Design Product: Subject to compliance with requirements, provide Sherwin Williams: Pro Industrial Pro Cryl Universal Primer, B66 Series (5-10 mil wet, 1.8-3.6 mil dry) or Approved Equivalent by one of the following:
 - a. Behr Paint Company (Behr Process LLC)
 - b. Benjamin Moore & Co.
 - c. Hempel (USA), Inc.
 - d. Rodda Paint Co.
 - e. The Pittsburgh Paints Company

2.3 WATER-BASED FINISH COATINGS

- A. Exterior, High-Performance Architectural Latex (PT-14): Water-based, pigmented, low VOC, emulsion coating formulated for use on exterior substrates.
 - 1. Basis-of-Design Product: Subject to compliance with requirements, provide Sherwin-Williams: Sher-Cryl High Performance Acrylic Semi-gloss, B66 Series or Approved Equivalent by one of the following:
 - a. Behr Paint Company (Behr Process LLC)
 - b. Benjamin Moore & Co.
 - c. The Pittsburgh Paints Company
 - 2. Gloss Level: Manufacturer's standard semigloss.

PART 3 - EXECUTION

3.1 PREPARATION

- A. Comply with manufacturer's written instructions applicable to substrates and paint systems indicated.
- B. Clean substrates of substances that could impair bond of paints, including dust, dirt, oil, grease, and incompatible paints and encapsulants.
 - 1. Remove incompatible primers and reprime substrate with compatible primers or apply tie coat as required to produce paint systems specified in this Section.
- C. Galvanized-Metal Substrates: Remove grease and oil residue from galvanized metal by mechanical methods to produce clean, lightly etched surfaces that promote adhesion of subsequently applied paints.
 - 1. Check for presence of a passivator. If a passivator is found, cleaning with Great Lakes Clean-N-Etch can be done to prevent adhesion issues from contamination.

3.2 APPLICATION OF EXTERIOR PAINT PRODUCTS

- A. Apply paints in accordance with manufacturer's written instructions.
 - 1. Use applicators and techniques suited for paint and substrate indicated.
 - 2. Paint surfaces behind movable items same as similar exposed surfaces. Before final installation, paint surfaces behind permanently fixed items with prime coat only.
 - 3. Do not paint over labels of independent testing agencies or equipment name, identification, performance rating, or nomenclature plates.
 - 4. Primers specified in applicable exterior painting schedule articles may be omitted on items that are factory primed or factory finished if compatible with intermediate and topcoat coatings and acceptable to intermediate and topcoat paint manufacturers.
- B. Tint each undercoat a lighter shade to facilitate identification of each coat if multiple coats of same material are to be applied. Tint undercoats to match color of topcoat but provide sufficient difference in shade of undercoats to distinguish each separate coat.
- C. If undercoats or other conditions show through topcoat, apply additional coats until cured film has a uniform paint finish, color, and appearance.
- D. Apply paints to produce surface films without cloudiness, spotting, holidays, laps, brush marks, roller tracking, runs, sags, ropiness, or other surface imperfections. Cut in sharp lines and color breaks.

3.3 FIELD QUALITY CONTROL

- A. Dry Film Thickness Testing: Owner may engage the services of a qualified testing and inspecting agency to inspect and test paint for dry film thickness.
 - 1. Touch up and restore painted surfaces damaged by testing.
 - 2. If test results show that dry film thickness of applied paint does not comply with paint manufacturer's written instructions, apply additional coats as needed to provide dry film thickness that complies with paint manufacturer's written instructions.
 - 3. Cost of retesting is Contractor's responsibility.

3.4 EXTERIOR PAINTING SCHEDULE, METAL SUBSTRATES

- A. Galvanized Metal Substrates:
 - 1. Water-Based Coating and Acrylic Coating
 - a. Prime Coat: Water-based, Galvanized-Metal Primer
 - b. Intermediate Coat: Matching topcoat.
 - c. Topcoat: Exterior, water-based, acrylic coating, semigloss

END OF SECTION 099113

SECTION 099123 - INTERIOR PAINTING

PART 1 - GENERAL

1.1 SUMMARY

- A. Section Includes: Surface preparation of interior substrates and application of the following:
 - 1. Primers.
 - 2. Water-based finish coatings.
 - 3. Solvent-based finish coatings.
 - 4. Dry fall coatings.
- B. Related Requirements:
 - 1. Section 055000 "Metal Fabrications" for shop priming metal fabrications.
 - 2. Section 099113 "Exterior Painting."
 - 3. Section 099300 "Staining and Transparent Finishing" for surface preparation and application of wood stains and transparent finishes on interior wood substrates.

1.2 ACTION SUBMITTALS

- A. Product Data: For each type of product.
 - 1. Include preparation requirements and application instructions.
 - 2. Indicate VOC content.
- B. Samples for Verification: For each type of paint system and each color and gloss of topcoat. Submit actual paint drawdowns as specified below for verification Samples.
 - 1. Submit Samples on rigid backing, **8 inches** square.
 - 2. Apply coats on Samples in steps to show each coat required for system.
 - 3. Label each coat of each Sample.
 - 4. Label each Sample for location and application area.
- C. Product List: Cross-reference to paint system and locations of application areas. Use same designations indicated on Drawings and in applicable interior painting schedule articles to cross-reference paint systems specified in this Section. Include color designations.
- D. Sustainable Design Submittals:
 - 1. Product Data: For paints and coatings, indicating VOC content.

1.3 MAINTENANCE MATERIAL SUBMITTALS

- A. Furnish extra materials that match paint products applied and that are packaged with protective covering for storage and identified with labels describing contents.
 - 1. Paint Products: 5 percent, but not less than **1 gal.** of each material and color applied.

1.4 DELIVERY, STORAGE, AND HANDLING

- A. Store materials not in use in tightly covered containers in well-ventilated areas with ambient temperatures continuously maintained at not less than **45 deg F.**
 - 1. Maintain containers in clean condition, free of foreign materials and residue.
 - 2. Remove rags and waste from storage areas daily.

1.5 FIELD CONDITIONS

- A. Apply paints only when temperature of surfaces to be painted and ambient air temperatures are between **50 and 95 deg F.**
- B. Do not apply paints when relative humidity exceeds 85 percent; at temperatures of less than **5 deg F** above the dew point; or to damp or wet surfaces.

PART 2 - PRODUCTS

2.1 SOURCE LIMITATIONS

- A. Obtain each paint product from single source from single manufacturer.

2.2 INTERIOR PAINTS, GENERAL

- A. Interior Paints: Subject to compliance with requirements, provide product listed in product types below and applicable interior painting schedule articles for the paint category indicated.
- B. Material Compatibility:
 - 1. Materials for use within each paint system must be compatible with one another and substrates indicated, under conditions of service and application as demonstrated by manufacturer based on testing and field experience.
 - 2. For each coat in a paint system, provide products recommended in writing by topcoat manufacturer for use in paint system and on substrate indicated.
- C. VOC Content: For field applications, verify paints and coatings comply with VOC content limits of authorities having jurisdiction and the following VOC content limits:

1. Flat Paints and Coatings: 50 g/L.
2. Nonflat Paints and Coatings: 50 g/L.
3. Primers, Sealers, and Undercoaters: 100 g/L.
4. Rust-Preventive Coatings: 100 g/L.
5. Zinc-Rich Industrial Maintenance Primers: 100 g/L.
6. Pretreatment Wash Primers: 420 g/L.
7. Floor Coatings: 50 g/L.
8. Shellacs, Clear: 730 g/L.
9. Shellacs, Pigmented: 550 g/L.

D. Colors: See Finish Schedule.

2.3 PRIMERS

- A. Interior Latex Primer Sealer: Pigmented, water-based latex sealer; formulated to reduce porosity of substrate for finish coats; for use on new interior plaster, concrete, and gypsum board substrates. Not intended for use on wood or previously painted surfaces.

2.4 DRY FALL COATINGS

- A. Dry Fall, Water-Based for Galvanized Steel: Pigmented, water-based coating for direct application to cleaned, interior galvanized-metal ceiling surfaces and adjacent primed metals.
1. Basis-of-Design Product: Subject to compliance with requirements, provide Sherwin-Williams Company (The) or comparable product by one of the following:
 - a. Behr Paint Company (Behr Process LLC)
 - b. Benjamin Moore & Co.
 - c. The Pittsburgh Paints Company
 2. Gloss and Sheen Level: Manufacturer's standard eggshell semigloss Per Finish Schedule.

PART 3 - EXECUTION

3.1 EXAMINATION

- A. Examine substrates and conditions, with Applicator present, for compliance with requirements for maximum moisture content and other conditions affecting performance of the Work.
- B. Maximum Moisture Content of Substrates: When measured with an electronic moisture meter as follows:
1. Concrete: 12 percent.

2. Cementitious Composition Board: 12 percent.
 3. Masonry (Clay and CMU): 12 percent.
 4. Wood: 15 percent.
 5. Gypsum Board: 12 percent. Verify that finishing compound is dry and sanded smooth.
 6. Plaster: 12 percent. Verify that plaster is fully cured.
- C. Verify suitability of substrates, including surface conditions and compatibility, with finishes and primers. Proceed with coating application only after unsatisfactory conditions have been corrected.
1. Application of coating indicates acceptance of surfaces and conditions.

3.2 PREPARATION

- A. Comply with manufacturer's written instructions applicable to substrates and paint systems indicated.
- B. Remove hardware, covers, plates, and similar items already in place that are removable and are not to be painted. If removal is impractical or impossible because of size or weight of item, provide surface-applied protection before surface preparation and painting.
1. After completing painting operations, use workers skilled in the trades involved to reinstall items that were removed. Remove surface-applied protection if any.
- C. Clean substrates of substances that could impair bond of paints, including dust, dirt, oil, grease, and incompatible paints and encapsulants.
1. Remove incompatible primers and reprime substrate with compatible primers or apply tie coat as required to produce paint systems indicated.
- D. Remove all loose, peeling, or defective paint down to a sound substrate. Feather the edges of the removed paint to prevent a visible ridge in the work.
1. Fill cracks and small holes with patching material appropriate for the substrate and recommended by the paint manufacturer. Feather the patching material to match adjacent surfaces.
 2. Clean and dull any sound, existing paint film to provide a uniform, clean, and sound surface ready for priming.
- E. Concrete Substrates: Remove release agents, curing compounds, efflorescence, and chalk. Do not paint surfaces if moisture content or alkalinity of surfaces to be painted exceeds that permitted in manufacturer's written instructions.
- F. Masonry Substrates: Remove efflorescence and chalk. Do not paint surfaces if moisture content or alkalinity of surfaces or mortar joints to be painted exceeds that permitted in manufacturer's written instructions.
- G. Steel Substrates: Remove loose rust, loose mill scale, loose shop primer, and other

loose foreign matter. Clean using methods recommended in writing by paint manufacturer but not less than the following:

1. SSPC-SP 2.
- H. Shop-Primed Steel Substrates: Clean field welds, bolted connections, and areas where shop paint is abraded. Paint exposed areas with the same material as used for shop priming to comply with SSPC-PA 1 for touching up shop-primed surfaces.
- I. Galvanized Metal Substrates: Remove grease and oil residue from galvanized metal by mechanical methods to produce clean, lightly etched surfaces that promote adhesion of subsequently applied paints.
- J. Aluminum Substrates: Remove loose surface oxidation.
- K. Wood Substrates:
1. Scrape and clean knots. Before applying primer, apply coat of knot sealer recommended in writing by topcoat manufacturer for interior use in paint system indicated.
 2. Sand surfaces that will be exposed to view and remove sanding dust.
 3. Prime edges, ends, faces, undersides, and backsides of wood.
 4. After priming, fill holes and imperfections in the finish surfaces with putty or plastic wood filler. Sand smooth when dried.
- L. Canvas and Cotton Insulation Covering Substrates: Remove dust, dirt, and other foreign material that might impair bond of paints to substrates.
- M. Plastic Trim Fabrication Substrates: Remove dust, dirt, and other foreign material that might impair bond of paints to substrates.

3.3 APPLICATION OF INTERIOR PAINT PRODUCTS

- A. Apply paints in accordance with manufacturer's written instructions.
1. Use applicators and techniques suited for paint and substrate indicated.
 - a. Use primers specifically designer for repainting applications of existing conditions where required by the manufacturer.
 2. Paint surfaces behind movable equipment and furniture same as similar exposed surfaces. Before final installation, paint surfaces behind permanently fixed equipment or furniture with prime coat only.
 3. Paint front and backsides of access panels, removable or hinged covers, and similar hinged items to match exposed surfaces.
 4. Paint entire exposed surface of window frames and sashes.
 5. Do not paint over labels of independent testing agencies or equipment name, identification, performance rating, or nomenclature plates.
 6. Primers specified in the applicable interior painting schedule articles may be omitted on items that are factory primed or factory finished if compatible with

intermediate and topcoat coatings and acceptable to intermediate and topcoat paint manufacturers.

- B. Tint each undercoat a lighter shade to facilitate identification of each coat if multiple coats of same material are to be applied. Tint undercoats to match color of topcoat but provide sufficient difference in shade of undercoats to distinguish each separate coat.
- C. If undercoats or other conditions show through topcoat, apply additional coats until cured film has a uniform paint finish, color, and appearance.
- D. Apply paints to produce surface films without cloudiness, spotting, holidays, laps, brush marks, roller tracking, runs, sags, ropiness, or other surface imperfections. Cut in sharp lines and color breaks.
- E. Painting Fire-Suppression, Plumbing, HVAC, Electrical, Communication, and Electronic Safety and Security Work:
 - 1. Paint the following work where exposed to view in occupied spaces:
 - a. Equipment, including panelboards.
 - b. Uninsulated metal piping.
 - c. Uninsulated plastic piping.
 - d. Pipe hangers and supports.
 - e. Metal conduit.
 - f. Plastic conduit.
 - g. Duct, equipment, and pipe insulation having cotton or canvas insulation covering or other paintable jacket material.
 - h. Other items as directed by Architect.
 - 2. Paint portions of internal surfaces of metal ducts, without liner, behind air inlets and outlets that are visible from occupied spaces.

3.4 FIELD QUALITY CONTROL

- A. Dry-Film Thickness Testing: Owner may engage the services of a qualified testing and inspecting agency to inspect and test paint for dry-film thickness.
 - 1. Touch up and restore painted surfaces damaged by testing.
 - 2. If test results show that dry-film thickness of applied paint does not comply with paint manufacturer's written recommendations, apply additional coats as needed to provide dry-film thickness that complies with paint manufacturer's written recommendations.
 - 3. Cost of retesting is Contractor's responsibility.

3.5 CLEANING AND PROTECTION

- A. At end of each workday, remove rubbish, empty cans, rags, and other discarded materials from Project site.

1. Do not clean equipment with free-draining water and prevent solvents, thinners, cleaners, and other contaminants from entering into waterways, sanitary and storm drain systems, and ground.
 2. Dispose of contaminants in accordance with requirements of authorities having jurisdiction.
 3. Allow empty paint cans to dry before disposal.
- B. After completing paint application, clean spattered surfaces. Remove spattered paints by washing, scraping, or other methods. Do not scratch or damage adjacent finished surfaces.
- C. Protect work of other trades against damage from paint application. Correct damage to work of other trades by cleaning, repairing, replacing, and refinishing, as approved by Architect, and leave in an undamaged condition.
- D. At completion of construction activities of other trades, touch up and restore damaged or defaced painted surfaces.

3.6 INTERIOR PAINTING SCHEDULE, CONCRETE SUBSTRATES

- A. Vertical (Nontraffic) Surfaces:
1. Latex System :
 - a. Prime Coat: Matching topcoat.
 - b. Intermediate Coat: Matching topcoat.
 - c. Topcoat: ProMar 200 Zero VOC Interior Latex Egshel, B20 Series.

3.7 INTERIOR PAINTING SCHEDULE, METAL SUBSTRATES

- A. Galvanized Metal Substrates:
1. Latex System :
 - a. Prime Coat: Pro Industrial Pro Cryl Universal Primer, B66 Series
 - b. Intermediate Coat: Matching topcoat.
 - c. Topcoat: Per Finish Schedule Pro Industrial Acrylic Semi-Gloss, B66 Series OR Sherwin-Williams ProMar 200 Zero VOC Interior Latex Eggsh.g-shel, B20 Series
 - d. Prep: Clean with Great Lakes Labs Clean N Etch
- B. Non-Galvanized Metal Substrates:
1. Latex System
 - a. Primer: Pro Industrial Pro Cryl Universal Primer, B66 Series
 - b. Intermediate Coat: Matching topcoat.
 - c. Topcoat: Pro Industrial Acrylic Semi-Gloss, B66 Series OR Sherwin Williams ProMar 200 Zero VOC Interior Latex Eg-shel, B20 Series

C. Hollow Metal Doors:

1. Latex System

- a. Primer: Pro Industrial Pro Cryl Universal Primer, B66 Series
- b. Intermediate Coat: Matching topcoat
- c. Topcoat: Sherwin-Williams Pro Industrial Waterbased Alkyd Urethane Enamel Semi-Gloss, B53 Series

3.8 INTERIOR PAINTING SCHEDULE, WOOD SUBSTRATES

A. Finish Carpentry Substrates: Wood trim.

1. Latex over Latex Primer System :

- a. Prime Coat: Extreme Bond Primer, B51 Series
- b. Intermediate Coat: Matching topcoat.
- c. Topcoat: Pro Industrial Waterbased Alkyd Urethane Enamel Semi-Gloss, B53 Series Per Finish Schedule

3.9 INTERIOR PAINTING SCHEDULE, GYPSUM-BASED SUBSTRATES

A. Gypsum Board and Plaster Substrates:

1. Latex over Latex Sealer System :

- a. Prime Coat: ProMar 200 Zero VOC Interior Latex Primer, B28 Series.
- b. Intermediate Coat: Matching topcoat.
- c. Topcoat: ProMar 200 Zero VOC Interior Latex Flat, B30 Series .
 - 1) Interior Walls: Eggshell
 - 2) Horizontal Ceiling: Flat

END OF SECTION 099123

SECTION 099300 - STAINING AND TRANSPARENT FINISHING

PART 1 - GENERAL

1.1 SUMMARY

1.2 ACTION SUBMITTALS

A. Product Data:

1. For each type of product.
2. Include preparation requirements and application instructions.
3. Indicate VOC content.

B. Samples for Verification: Sample for each type of finish system and in each color and gloss of finish required on representative samples of actual wood substrates.

1. Size: **8 inches** long.
2. Provide three different stain options on proposed wood species for design approval.
3. Apply coats on Samples in steps to show each coat required for system.
4. Label each coat of each Sample.
5. Label each Sample for location and application area.

C. Product List: Cross-reference to finish system and locations of application areas. Use same designations indicated on Drawings and in schedules. Include color designations.

1.3 MAINTENANCE MATERIAL SUBMITTALS

A. Extra Stock Material: Furnish extra materials, from the same product run, that match products installed and that are packaged with protective covering for storage and identified with labels describing contents.

1. Stains and Transparent Finishes: 5 percent, but not less than **1 gal.** of each material and color applied.

1.4 DELIVERY, STORAGE, AND HANDLING

A. Store materials not in use in tightly covered containers in well-ventilated areas with ambient temperatures continuously maintained at not less than **45 deg F.**

1. Maintain containers in clean condition, free of foreign materials and residue.
2. Remove rags and waste from storage areas daily.

1.5 FIELD CONDITIONS

- A. Apply finishes only when temperature of surfaces to be finished and ambient air temperatures are between **50 and 95 deg F**.
- B. Do not apply finishes when relative humidity exceeds 85 percent, at temperatures of less than **5 deg F** above the dew point, or to damp or wet surfaces.
- C. Do not apply exterior finishes in snow, rain, fog, or mist.

PART 2 - PRODUCTS

2.1 SOURCE LIMITATIONS

- A. Source Limitations: Obtain each coating product from single source from single manufacturer.

2.2 STAINING AND TRANSPARENT FINISHING (WS-1)

- A. Basis-of-Design Product: Subject to compliance with requirements, provide Sherwin-Williams Company; Minwax, Water-Based or comparable product by one of the following:
 - 1. Behr Paint Company (Behr Process LLC)
 - 2. Benjamin Moore & Co.
 - 3. Coronado Paint; Benjamin Moore & Co.
 - 4. Diamond Vogel Paint Company
 - 5. Dunn-Edwards Corporation (a Nippon Paint Holdings Co. Ltd. company)
 - 6. Hempel (USA), Inc.
 - 7. Lenmar Lacquers; Benjamin Moore & Co.
 - 8. Pratt & Lambert; a subsidiary of The Sherwin-Williams Company
 - 9. Rodda Paint Co.
 - 10. Rust-Oleum Corporation
 - 11. The Pittsburgh Paints Company
 - 12. United Gilsonite Laboratories (UGL)
 - 13. Vista Paint Corporation
- B. Material Compatibility:
 - 1. Provide materials for use within each coating system that are compatible with one another and substrates indicated, under conditions of service and application as demonstrated by manufacturer, based on testing and field experience.
 - 2. Clear Wood Finishes, Varnishes: 350 g/L.
 - 3. Clear Wood Finishes, Lacquers: 550 g/L.
 - 4. Shellacs, Clear: 730 g/L.
 - 5. Stains: 250 g/L.
 - 6. Primers, Sealers, and Undercoaters: 100 g/L.
 - 7. Clear Wood Finishes, Varnishes: 275 g/L.

8. Clear Wood Finishes, Lacquers: 275 g/L.
 9. Shellacs, Clear: 730 g/L.
 10. Stains: 100 g/L.
- C. Material Emissions and Pollutant Control: Not less than 85 percent of field-applied paints and coatings that are inside the weatherproofing system shall comply with the following:
- D. Emissions Requirements: Field-applied paints and coatings that are inside the weatherproofing system shall comply with either of the following:
1. VOC content shall not exceed limits of authorities having jurisdiction and the following:
 - a. Shellacs, Clear: 730 g/L.
 - b. Stains: 250 g/L.
 - c. Clear Wood Finishes (Varnishes, Sanding Sealers, and Lacquers): 275 g/L.
- E. Stain Colors: Per Finish Schedule.

2.3 STAINING AND TRANSPARENT FINISHING 2 (WS-2, WS-3, WS-4)

- A. Basis-of-Design Product: Subject to compliance with requirements, provide Minwax; Wood Finish Penetrating Stain or comparable product by one of the following:
1. Behr Paint Company (Behr Process LLC)
 2. Benjamin Moore & Co.
 3. Coronado Paint; Benjamin Moore & Co.
 4. Diamond Vogel Paint Company
 5. Dunn-Edwards Corporation (a Nippon Paint Holdings Co. Ltd. company)
 6. Hempel (USA), Inc.
 7. Lenmar Lacquers; Benjamin Moore & Co.
 8. Pratt & Lambert; a subsidiary of The Sherwin-Williams Company
 9. Rodda Paint Co.
 10. Rust-Oleum Corporation
 11. Sherwin-Williams Company (The)
 12. The Pittsburgh Paints Company
 13. United Gilsonite Laboratories (UGL)
 14. Vista Paint Corporation
- B. Material Compatibility:
1. Provide materials for use within each coating system that are compatible with one another and substrates indicated, under conditions of service and application as demonstrated by manufacturer, based on testing and field experience.
 2. Clear Wood Finishes, Varnishes: 350 g/L.
 3. Clear Wood Finishes, Lacquers: 550 g/L.
 4. Shellacs, Clear: 730 g/L.
 5. Stains: 250 g/L.
 6. Primers, Sealers, and Undercoaters: 100 g/L.

7. Clear Wood Finishes, Varnishes: 275 g/L.
 8. Clear Wood Finishes, Lacquers: 275 g/L.
 9. Shellacs, Clear: 730 g/L.
 10. Stains: 100 g/L.
- C. Material Emissions and Pollutant Control: Not less than 85 percent of field-applied paints and coatings that are inside the weatherproofing system shall comply with the following:
1. Low-Emitting Materials: VOC emissions shall comply with the requirements of the California Department of Public Health's "Standard Method for the Testing and Evaluation of Volatile Organic Chemical Emissions from Indoor Sources Using Environmental Chambers." Formaldehyde emissions shall not exceed 9 mcg/cu. m or 7 ppb, whichever is less.
- D. Emissions Requirements: Field-applied paints and coatings that are inside the weatherproofing system shall comply with either of the following:
1. Low-Emitting Materials: VOC emissions shall comply with the requirements of the California Department of Public Health's "Standard Method for the Testing and Evaluation of Volatile Organic Chemical Emissions from Indoor Sources Using Environmental Chambers."
 2. VOC content shall not exceed limits of authorities having jurisdiction and the following:
 - a. Shellacs, Clear: 730 g/L.
 - b. Stains: 250 g/L.
 - c. Clear Wood Finishes (Varnishes, Sanding Sealers, and Lacquers): 275 g/L.
- E. Stain Colors: Per Finish Schedule.

PART 3 - EXECUTION

3.1 EXAMINATION

- A. Examine substrates and conditions, with Applicator present, for compliance with requirements for maximum moisture content and other conditions affecting performance of the Work.
- B. Maximum Moisture Content of Exterior Wood Substrates: 15 percent, when measured with an electronic moisture meter.
- C. Maximum Moisture Content of Interior Wood Substrates: 10 percent, when measured with an electronic moisture meter.
- D. Verify suitability of substrates, including surface conditions and compatibility with existing finishes and primers.
- E. Proceed with finish application only after unsatisfactory conditions have been

corrected.

1. Beginning finish application constitutes Contractor's acceptance of substrates and conditions.

3.2 PREPARATION

- A. Remove hardware, covers, plates, and similar items already in place that are removable. If removal is impractical or impossible because of size or weight of item, provide surface-applied protection before surface preparation and finishing.
 1. After completing finishing operations, use workers skilled in the trades involved to reinstall items that were removed. Remove surface-applied protection if any.
- B. Clean and prepare surfaces to be finished according to manufacturer's written instructions for each substrate condition and as specified.
 1. Remove dust, dirt, oil, and grease by washing with a detergent solution; rinse thoroughly with clean water and allow to dry. Remove grade stamps and pencil marks by sanding lightly. Remove loose wood fibers by brushing.
 2. Remove mildew by scrubbing with a commercial wash formulated for mildew removal and as recommended by stain manufacturer.
- C. Exterior Wood Substrates:
 1. Scrape and clean knots, and apply coat of knot sealer before applying primer.
 2. Prime edges, ends, faces, undersides, and backsides of wood.
 - a. For solid hide stained wood, stain edges and ends after priming.
 - b. For varnish-coated stained wood, stain edges and ends and prime with varnish. Prime undersides and backsides with varnish.
 3. Countersink steel nails, if used, and fill with putty or plastic wood filler tinted to final color. Sand smooth when dried.
- D. Interior Wood Substrates:
 1. Scrape and clean knots, and apply coat of knot sealer before applying primer.
 2. Apply wood filler paste to open-grain woods to produce smooth, glasslike finish.
 3. Sand surfaces exposed to view and dust off.
 4. After priming, fill holes and imperfections in the finish surfaces with putty or plastic wood filler. Sand smooth when dry.

3.3 APPLICATION

- A. Apply finishes according to manufacturer's written instructions.
 1. Use applicators and techniques suited for finish and substrate indicated.
 2. Finish surfaces behind movable equipment and furniture same as similar

exposed surfaces.

3. Do not apply finishes over labels of independent testing agencies or equipment name, identification, performance rating, or nomenclature plates.

- B. Apply finishes to produce surface films without cloudiness, holidays, lap marks, brush marks, runs, ropiness, or other surface imperfections.

3.4 CLEANING AND PROTECTION

- A. At end of each workday, remove rubbish, empty cans, rags, and other discarded materials from Project site.
- B. After completing finish application, clean spattered surfaces. Remove spattered materials by washing, scraping, or other methods. Do not scratch or damage adjacent finished surfaces.
- C. Protect work of other trades against damage from finish application. Correct damage by cleaning, repairing, replacing, and refinishing, as approved by Architect, and leave in an undamaged condition.
- D. At completion of construction activities of other trades, touch up and restore damaged or defaced finished wood surfaces.

3.5 INTERIOR WOOD-FINISH-SYSTEM SCHEDULE

- A. Wood Substrates, Exposed Framing:

1. Water-Based Varnish over Stain System :

- a. Stain Coat: Stain, semitransparent, for interior wood.
- b. First Intermediate Coat: Water-based varnish matching topcoat.
- c. Second Intermediate Coat: Water-based varnish matching topcoat.
- d. Topcoat: Varnish, water based, clear, satin.

- B. Wood Substrates, Wood Trim Architectural Woodwork and Wood Board Paneling:

1. Water-Based Varnish over Stain System :

- a. Stain Coat: Stain, semitransparent, for interior wood.
- b. First Intermediate Coat: Water-based varnish matching topcoat.
- c. Second Intermediate Coat: Water-based varnish matching topcoat.
- d. Topcoat: Varnish, water based, clear, satin.

- C. Wood Substrates, **[Wood Paneling][and][Casework]**:

1. Water-Based Varnish over Stain System :

- a. Stain Coat: Stain, semitransparent, for interior wood.
- b. First Intermediate Coat: Water-based varnish matching topcoat.

- c. Second Intermediate Coat: Water-based varnish matching topcoat.
- d. Topcoat: Varnish, water based, clear, satin.

END OF SECTION 099300

SECTION 099653 - ELASTOMERIC COATINGS

PART 1 - GENERAL

1.1 SUMMARY

- A. Related Requirements:
 - 1. Section 099113 "Exterior Painting."

1.2 ACTION SUBMITTALS

- A. Product Data: For each type of product.
 - 1. Include preparation requirements and application instructions.
 - 2. Indicate VOC content.
- B. Samples for Initial Selection: For each type of elastomeric topcoat product.
- C. Product List: Cross-reference to coating system and locations of application areas. Use same designations indicated on Drawings and in the Elastomeric Coating Schedule to cross-reference coating systems specified in this Section. Include color designations.

1.3 FIELD CONDITIONS

- A. Apply coatings only when temperature of surfaces to be coated and ambient air temperatures are between **50 and 90 deg F** unless otherwise permitted by manufacturer's written instructions.
- B. Do not apply coatings in snow, rain, fog, or mist; when relative humidity exceeds 85 percent; at temperatures less than **5 deg F** above the dew point; or to damp or wet surfaces.
- C. Allow wet surfaces to dry thoroughly and attain temperature and conditions specified before starting or continuing coating operation.

1.4 WARRANTY

- A. Special Warranty: Manufacturer's standard form in which manufacturer agrees to repair or replace elastomeric coatings that fail within specified warranty period.
 - 1. Failures include, but are not limited to, the following:
 - a. Water penetration through the coating.
 - b. Deterioration of coating beyond normal weathering.

2. Warranty Period: 10 years from date of Substantial Completion.

PART 2 - PRODUCTS

2.1 SOURCE LIMITATIONS

- A. Obtain each coating system product from single source from single manufacturer.

2.2 ELASTOMERIC COATINGS, GENERAL

- A. Moisture-Vapor Transmission: Minimum 4, based on testing in accordance with ASTM D1653.
- B. Material Compatibility:
 1. Materials for use within each coating system are compatible with one another and substrates indicated, under conditions of service and application as demonstrated by manufacturer, based on testing and field experience.
 2. For each coat in a coating system, products are recommended in writing by manufacturers of topcoat for use in elastomeric coating system and on substrate indicated.
 3. Flat Paints and Coatings: 50 g/L.
 4. Nonflat Paints and Coatings: 50 g/L.
 5. Dry-Fog Coatings: 150 g/L.
 6. Primers, Sealers, and Undercoaters: 100 g/L.
 7. Rust-Preventive Coatings: 100 g/L.
 8. Zinc-Rich Industrial Maintenance Primers: 100 g/L.
 9. Pretreatment Wash Primers: 420 g/L.
 10. Shellacs, Clear: 730 g/L.
 11. Shellacs, Pigmented: 550 g/L.
- C. Colors: As selected by Architect from manufacturer's full range.
- D. Crack Fillers: Elastomeric coating manufacturer's recommended, factory-formulated crack fillers or sealants, including crack filler primers, compatible with substrate and other materials indicated.
- E. Primer: Elastomeric coating manufacturer's recommended, factory-formulated, alkali-resistant primer compatible with substrate and other materials indicated.
- F. Concrete Masonry Unit Block Filler: Elastomeric coating manufacturer's recommended, factory-formulated, high-performance latex block filler compatible with substrate and other materials indicated.

PART 3 - EXECUTION

3.1 APPLICATION OF ELASTOMERIC COATING SYSTEMS

- A. Apply elastomeric coatings in accordance with manufacturer's written instructions.
 - 1. Use equipment and techniques best suited for substrate and type of material being applied.
 - 2. Coat surfaces behind movable items the same as similar exposed surfaces.
 - 3. Apply each coat separately in accordance with manufacturer's written instructions.
- B. Primers: Apply at a rate to ensure complete coverage.
- C. Block Fillers: Apply at a rate to ensure complete coverage with pores filled.
- D. Elastomeric Finish Coat(s): Minimum two coats with a total dry film thickness of **16 to 18 mils**.
- E. Tint each undercoat a lighter shade to facilitate identification of each coat if multiple coats of same material are to be applied. Tint undercoats similar to color of topcoat, but provide sufficient difference in shade of undercoats to distinguish each separate coat.
- F. If undercoats or other conditions show through topcoat, apply additional coats until cured film has a uniform finish, color, and appearance.
- G. Apply coatings to produce surface films without cloudiness, spotting, holidays, laps, brush marks, roller tracking, runs, sags, ropiness, or other surface imperfections. Cut in sharp lines and color breaks.
- H. Apply coatings to prepared surfaces as soon as practicable after preparation and before subsequent surface soiling or deterioration.
- I. Spray Application: Use spray equipment for application only when permitted by authorities having jurisdiction. Wherever spray application is used, do not double back with spray equipment to build up film thickness of two coats in one pass.

3.2 FIELD QUALITY CONTROL

- A. Testing of Paint Materials: Owner reserves the right to invoke the following testing procedures:
 - 1. Owner will engage the services of a qualified testing agency to sample materials being used. Samples of material delivered to Project site will be taken, identified, sealed, and certified in presence of Contractor.
 - 2. Testing agency will perform tests for compliance of materials with product requirements.
 - 3. Owner may direct Contractor to stop coating application if test results show materials being used do not comply with requirements. Remove noncomplying

materials from Project site, pay for testing, and recoat surfaces that were coated with rejected materials. Remove rejected materials from previously coated surfaces if, on recoating with complying materials, the two coatings are incompatible.

- B. Field Testing and Inspection: Owner reserves the right to engage the services of a qualified testing agency to verify installed thickness of elastomeric coatings.

3.3 CLEANING AND PROTECTION

- A. At end of each workday, remove rubbish, empty cans, rags, and other discarded materials from Project site.
- B. After completing coating application, clean spattered surfaces. Remove spattered coatings by washing, scraping, or other methods. Do not scratch or damage adjacent finished surfaces.
- C. Protect work of other trades against damage from coating application. Correct damage to work of other trades by cleaning, repairing, replacing, and refinishing, as approved by Architect, and leave in an undamaged condition.
- D. At completion of construction activities, touch up and restore damaged or defaced coated surfaces.

3.4 ELASTOMERIC COATING SCHEDULE

- A. Concrete Substrates:
 - 1. Elastomeric Coating System:
 - a. Prime Coat: As recommended in writing by topcoat manufacturer.
 - b. Intermediate Coat: As recommended in writing by topcoat manufacturer.
 - c. Topcoat: Elastomeric, pigmented, exterior, water-based, flat coating.
- B. Concrete Masonry Unit Substrates:
 - 1. Elastomeric Coating System:
 - a. Prime Coat: As recommended in writing by topcoat manufacturer.
 - b. Block Filler: As recommended in writing by topcoat manufacturer.
 - c. Intermediate Coat: As recommended in writing by topcoat manufacturer.
 - d. Topcoat: Elastomeric, pigmented, exterior, water-based, flat coating.
- C. Stucco Substrates:
 - 1. Elastomeric Coating System:
 - a. Prime Coat: As recommended in writing by topcoat manufacturer.
 - b. Intermediate Coat: As recommended in writing by topcoat manufacturer.

- c. Topcoat: Elastomeric, pigmented, exterior, water-based, flat coating.

END OF SECTION 099653

SECTION 102239 - FOLDING PANEL PARTITIONS

PART 1 - GENERAL

1.1 SUMMARY

A. Related Requirements:

1. Section 055000 "Metal Fabrications" for supports that attach supporting tracks to overhead structural system.
2. Section 092900 "Gypsum Board" for fire-rated assemblies and sound barrier construction above the ceiling at track.

1.2 ACTION SUBMITTALS

A. Product Data:

1. Operable acoustical panel partitions.

B. Shop Drawings: For operable panel partitions.

1. Include plans, elevations, sections, attachment details.
2. Indicate stacking and operating clearances. Indicate location and installation requirements for hardware and track, blocking, and direction of travel.

C. Samples for Initial Selection: For each type of exposed material, finish, covering, or facing.

1. Include Samples of accessories involving color selection.

1.3 INFORMATIONAL SUBMITTALS

A. Coordination Drawings: Reflected ceiling plans, drawn to scale, on which the following items are shown and coordinated with each other, using input from installers of the items involved:

1. Partition track, track supports and bracing, switches, turning space, and storage layout.
2. Suspended ceiling components.
3. Structural members to which suspension systems will be attached.
4. Size and location of initial access modules for acoustical tile.
5. Items penetrating finished ceiling including the following:
 - a. Lighting fixtures.
 - b. HVAC ductwork, outlets, and inlets.
 - c. Speakers.

- d. Sprinklers.
- e. Smoke detectors.
- f. Access panels.

6. Plenum fire barriers.

- B. Field quality-control reports.
- C. Sample Warranty: For manufacturer's special warranty.

1.4 CLOSEOUT SUBMITTALS

- A. Operation and Maintenance Data: For operable panel partitions to include in maintenance manuals.
 - 1. In addition to items specified in Section 017823 "Operation and Maintenance Data," include the following:
 - a. Panel finish facings and finishes for exposed trim and accessories. Include precautions for cleaning materials and methods that could be detrimental to finishes and performance.
 - b. Seals, hardware, track, track switches, carriers, and other operating components.

1.5 QUALITY ASSURANCE

- A. Installer Qualifications: An entity that employs installers and supervisors who are trained and approved by manufacturer.

1.6 WARRANTY

- A. Special Warranty: Manufacturer agrees to repair or replace components of operable panel partitions that fail in materials or workmanship within specified warranty period.
 - 1. Failures include, but are not limited to, the following:
 - a. Faulty operation of operable panel partitions.
 - b. Deterioration of metals, metal finishes, and other materials beyond normal use.

PART 2 - PRODUCTS

2.1 PERFORMANCE REQUIREMENTS

- A. Acoustical Performance: Provide operable panel partitions tested by a qualified testing agency for the following acoustical properties in accordance with test methods

indicated:

1. Sound-Transmission Requirements: Operable panel partition assembly tested for laboratory sound-transmission loss performance in accordance with ASTM E90, determined by ASTM E413, and rated for not less than the STC indicated.
 2. Noise-Isolation Requirements: Installed operable panel partition assembly, identical to partition tested for STC, tested for NIC in accordance with ASTM E336, determined by ASTM E413, and rated for 10 dB less than STC value indicated.
- B. Fire-Test-Response Characteristics: Provide panels with finishes complying with one of the following as determined by testing identical products by a testing and inspecting agency acceptable to authorities having jurisdiction:
1. Surface-Burning Characteristics: Comply with ASTM E84; testing by a qualified testing agency. Identify products with appropriate markings of applicable testing agency.
 - a. Flame-Spread Index: 25 or less.
 - b. Smoke-Developed Index: 450 or less.
 2. Fire Growth Contribution: Complying with acceptance criteria of local code and authorities having jurisdiction when tested in accordance with NFPA 265 Method B Protocol or NFPA 286.

2.2 OPERABLE ACOUSTICAL PANEL PARTITIONS

- A. Panel Operation: Manually operated, individual panels.
- B. Manufacturer: Modernfold, Inc; Acousti-Seal Premier Single Panel Operable Partition
- C. Panel Construction: As required to support panel from suspension components and with reinforcement for hardware attachment. Fabricate panels with tight hairline joints and concealed fasteners. Fabricate panels so finished in-place partition is rigid; level; plumb; aligned, with tight joints and uniform appearance; and free of bow, warp, twist, deformation, and surface and finish irregularities.
- D. Dimensions: Fabricate operable acoustical panel partitions to form an assembled system of dimensions indicated and verified by field measurements.
 1. Panel Width: As indicated.
- E. STC: Not less than 54.
- F. Panel Weight: 12 lb/sq. ft. maximum.
- G. Panel Thickness: Minimum dimension of 3 inches.
- H. Panel Closure: Manufacturer's standard unless otherwise indicated.

1. Acousti-Seal Premier - Single Panel (931): Series of individual flat panels, manually operated, top supported with operable floor seals.
 2. Final Closure: Architect to Select.
- I. Hardware: Manufacturer's standard as required to operate operable panel partition and accessories; with decorative, protective finish.
1. Hinges: Manufacturer's standard.
- J. Finish Facing: Manufacturer Standard.

2.3 SUSPENSION SYSTEMS

- A. Tracks: Steel or aluminum mounted directly to overhead structural support, per structural drawings and manufacturer requirements, designed for operation, size, and weight of operable panel partition indicated. Size track to support partition operation and storage without damage to suspension system, operable panel partitions, or adjacent construction. Limit track deflection to no more than **0.10 inch** between bracket supports. Provide a continuous system of track sections and accessories to accommodate configuration and layout indicated for partition operation and storage.
1. Panel Guide: Aluminum guide on both sides of the track to facilitate straightening of the panels; finished with factory-applied, decorative, protective finish.
 2. Head Closure Trim: As required for acoustical performance; with factory-applied, decorative, protective finish.
- B. Carriers: Trolley system as required for configuration type, size, and weight of partition and for easy operation; with ball-bearing wheels.
1. Multidirectional Carriers: Capable of negotiating intersections without track switches.
- C. Track Intersections, Switches, and Accessories: As required for operation, storage, track configuration, and layout indicated for operable panel partitions, and compatible with partition assembly specified. Fabricate track intersections and switches from steel or aluminum.
1. Curve-and-Diverter Switches: Allow radius turns to divert panels to an auxiliary track.
 2. L Intersections: Allow panels to change 90 degrees in direction of travel.
 3. T Intersections: Allow panels to pass through or change 90 degrees to another direction of travel.
 4. X Intersections: Allow panels to pass through or change travel direction full circle in 90-degree increments, and allow one partition to cross track of another.
 5. Multidirectional Switches: Adjustable switch configuring track into L, T, or X intersections and allowing panels to be moved in all pass-through, 90-degree change, and cross-over travel direction combinations.
 6. Center carrier stop.
- D. Aluminum Finish: Mill finish or manufacturer's standard, factory-applied, decorative

finish unless otherwise indicated.

- E. Steel Finish: Manufacturer's standard, factory-applied, corrosion-resistant, protective coating unless otherwise indicated.

PART 3 - EXECUTION

3.1 INSTALLATION OF OPERABLE PANEL PARTITIONS

- A. Install operable panel partitions and accessories after other finishing operations, including painting, have been completed in area of partition installation.
- B. Install panels in numbered sequence indicated on Shop Drawings.
- C. Broken, cracked, chipped, deformed, or unmatched panels are not acceptable.
- D. Broken, cracked, deformed, or unmatched gasketing or gasketing with gaps at butted ends is not acceptable.
- E. Light-Leakage Test: Illuminate one side of partition installation and observe vertical joints and top and bottom seals for voids. Adjust partitions for alignment and full closure of vertical joints and full closure along top and bottom seals. Perform test and make adjustments before NIC testing.

3.2 FIELD QUALITY CONTROL

- A. NIC Testing: Owner will engage a qualified testing agency to perform tests and inspections.
 - 1. Testing Extent: Testing agency is to randomly select operable panel partition installation(s) for testing.
 - 2. Testing Methodology: Perform testing of installed operable panel partition for noise isolation in accordance with ASTM E336, determined by ASTM E413, and rated for not less than NIC indicated. Adjust and fit partitions to comply with NIC test method requirements.
- B. An operable panel partition installation will be considered defective if it does not pass tests and inspections.
- C. Prepare test and inspection reports.

3.3 MAINTENANCE SERVICE

3.4 DEMONSTRATION

- A. Engage a factory-authorized service representative to train Owner's maintenance personnel to adjust, operate, and maintain operable panel partitions.

Intersect Studio, LLC
23046

Kalamazoo Crosstown
Parkway Facility
Kalamazoo, Michigan

END OF SECTION 102239

SECTION 102600 - WALL AND DOOR PROTECTION

PART 1 - GENERAL

1.1 SUMMARY

- A. Section Includes:
- B. Related Requirements:
 - 1. Section 057300 "Decorative Metal Railings" for metal handrails without plastic bumpers.
 - 2. Section 064023 "Interior Architectural Woodwork for solid-wood handrails, bumper rails, chair rails, or corner moldings without plastic bumpers.
 - 3. Section 087100 "Door Hardware" for metal and plastic protective trim units, according to BHMA A156.6, used for armor, kick, mop, and push plates.

1.2 ACTION SUBMITTALS

- A. Product Data: For each type of product.
 - 1. Include construction details, material descriptions, impact strength, dimensions of individual components and profiles, and finishes.
 - 2. Include fire ratings of units recessed in fire-rated walls and listings for door-protection items attached to fire-rated doors.
- B. Sustainable Design Submittals:
 - 1. Chain-of-Custody Certificates: For certified wood products. Include statement of costs.
- C. Shop Drawings: For each type of wall and door protection showing locations and extent.
- D. Samples for Initial Selection: For each type of impact-resistant wall-protection unit indicated, in each color and texture specified.
 - 1. Include Samples of accent strips and accessories to verify color selection.

1.3 INFORMATIONAL SUBMITTALS

- A. Material Certificates: For each type of exposed plastic material.
- B. Sample Warranty: For special warranty.

1.4 CLOSEOUT SUBMITTALS

- A. Maintenance Data: For each type of wall and door protection product to include in maintenance manuals.
1. Include recommended methods and frequency of maintenance for maintaining best condition of plastic covers under anticipated traffic and use conditions. Include precautions against using cleaning materials and methods that may be detrimental to finishes and performance.

1.5 DELIVERY, STORAGE, AND HANDLING

- A. Store wall and door protection in original undamaged packages and containers inside well-ventilated area protected from weather, moisture, soiling, extreme temperatures, and humidity.
1. Maintain room temperature within storage area at not less than **70 deg F** during the period plastic materials are stored.
 2. Keep plastic materials out of direct sunlight.
 3. Store plastic wall- and door-protection components for a minimum of 72 hours, or until plastic material attains a minimum room temperature of **70 deg F**.
 - a. Store corner-guard covers in a vertical position.
 - b. Store wall-guard covers in a horizontal position.

PART 2 - PRODUCTS

2.1 PERFORMANCE REQUIREMENTS

- A. Surface Burning Characteristics: Comply with ASTM E84 or UL 723; testing by a qualified testing agency. Identify products with appropriate markings of applicable testing agency.
1. Flame-Spread Index: 25 or less.
 2. Smoke-Developed Index: 450 or less.
- B. Regulatory Requirements: Comply with applicable provisions in ICC A117.1.

2.2 ABUSE-RESISTANT WALL COVERINGS

- A. Vinyl Sheet Wall Panels (WP-3): Rigid wall panels consisting of semirigid, plastic sheet wall covering material factory laminated to high-impact-resistant core, with moisture-resistant vapor barrier factory laminated to reverse side of panel for stability.
1. Basis-of-Design Product: Subject to compliance with requirements, provide Inpro; Paladium Rigid Sheet or Approved Equivalent by one of the following:

- a. Construction Specialties, Inc.
 - b. Inpro Corporation
2. Composition: **0.04-inch-** thick plastic sheet laminated to **3/8-inch-** thick particleboard or medium-density fiberboard core.
 3. Sheet Size: **48 by 96 inches.**
 4. Height: As indicated.
 5. Sheet Edge: Square Confirm with Architect.
 6. Trim and Joint Moldings: Extruded rigid plastic that matches wall-covering color.
 7. Color and Texture: See Finish Schedule.
 8. Mounting: Adhesive.
- B. Stainless Steel Wall Panel (STS-1/WP-4): Rigid wall panels consisting of semirigid, plastic sheet wall covering material factory laminated to high-impact-resistant core, with moisture-resistant vapor barrier factory laminated to reverse side of panel for stability.
1. Basis-of-Design Product: Subject to compliance with requirements, provide Inpro; Stainless Steel Wall Protection or Approved Equivalent by one of the following:
 - a. Construction Specialties, Inc.
 2. Composition: 18 gauge standard stainless steel.
 3. Sheet Size: 48 by 120 inches.
 4. Height: As indicated.
 5. Color and Texture: Brushed.
 6. Mounting: Adhesive.

2.3 MATERIALS

- A. Plastic Materials: Chemical- and stain-resistant, high-impact-resistant plastic with integral color throughout; extruded and sheet material as required, thickness as indicated.
- B. Polycarbonate Plastic Sheet: ASTM D6098, S-PC01, Class 1 or Class 2, abrasion resistant; with a minimum impact-resistance rating of **15 ft.-lbf/in.** of notch when tested according to ASTM D256, Test Method A.
- C. Solid Wood: Clear hardwood lumber of species indicated, free of appearance defects, and selected for compatible grain and color.
- D. Fasteners: Aluminum, nonmagnetic stainless-steel, or other noncorrosive metal screws, bolts, and other fasteners compatible with items being fastened. Use security-type fasteners where exposed to view.
- E. Adhesive: As recommended by protection product manufacturer.

2.4 FABRICATION

- A. Fabricate wall and door protection according to requirements indicated for design,

performance, dimensions, and member sizes, including thicknesses of components.

- B. Factory Assembly: Assemble components in factory to greatest extent possible to minimize field assembly. Disassemble only as necessary for shipping and handling.
- C. Quality: Fabricate components with uniformly tight seams and joints and with exposed edges rolled. Provide surfaces free of wrinkles, chips, dents, uneven coloration, and other imperfections. Fabricate members and fittings to produce flush, smooth, and rigid hairline joints.

2.5 FINISHES

- A. Protect finishes on exposed surfaces from damage by applying a strippable, temporary protective covering before shipping.
- B. Appearance of Finished Work: Noticeable variations in same piece are not acceptable. Variations in appearance of adjoining components are acceptable if they are within the range of approved Samples and are assembled or installed to minimize contrast.

PART 3 - EXECUTION

3.1 EXAMINATION

- A. Examine substrates and wall areas, with Installer present, for compliance with requirements for installation tolerances, fire rating, and other conditions affecting performance of the Work.
- B. Examine walls to which wall and door protection will be attached for blocking, grounds, and other solid backing that have been installed in the locations required for secure attachment of support fasteners.
 - 1. For wall and door protection attached with adhesive, verify compatibility with and suitability of substrates, including compatibility with existing finishes or primers.
- C. Proceed with installation only after unsatisfactory conditions have been corrected.

3.2 PREPARATION

- A. Complete finishing operations, including painting, before installing wall and door protection.
- B. Before installation, clean substrate to remove dust, debris, and loose particles.

3.3 INSTALLATION

- A. Installation Quality: Install wall and door protection according to manufacturer's written

instructions, level, plumb, and true to line without distortions. Do not use materials with chips, cracks, voids, stains, or other defects that might be visible in the finished Work.

- B. Mounting Heights: Install wall and door protection in locations and at mounting heights indicated on Drawings.
- C. Accessories: Provide splices, mounting hardware, anchors, trim, joint moldings, and other accessories required for a complete installation.
 - 1. Provide anchoring devices and suitable locations to withstand imposed loads.
 - 2. Where splices occur in horizontal runs of more than **20 feet**, splice aluminum retainers and plastic covers at different locations along the run, but no closer than **12 inches** apart.
 - 3. Adjust end and top caps as required to ensure tight seams.
- D. Abuse-Resistant Wall Covering: Install top and edge moldings, corners, and divider bars as required for a complete installation.
- E. Door-Frame Protectors: Install on both door jams.
- F. Fire Doors: Install protection according to the listing of each item.

3.4 CLEANING

- A. Immediately after completion of installation, clean plastic covers and accessories using a standard ammonia-based household cleaning agent.
- B. Remove excess adhesive using methods and materials recommended in writing by manufacturer.

END OF SECTION 102600

SECTION 102800 - TOILET, BATH, AND LAUNDRY ACCESSORIES

PART 1 - GENERAL

1.1 SUMMARY

A. Related Requirements:

1. Section 088300 "Mirrors" for frameless mirrors.
2. Section 093013 "Ceramic Tiling" for ceramic toilet and bath accessories.

1.2 ACTION SUBMITTALS

A. Product Data: For each product.

1. Include construction details, material descriptions, dimensions of individual components and profiles, and finishes.
2. Include anchoring and mounting requirements, including requirements for cutouts in other work and substrate preparation.
3. Include electrical characteristics.

B. Samples: For each exposed product and for each finish specified, full size.

C. Product Schedule: Indicating types, quantities, sizes, and installation locations by room of each accessory required.

1. Identify locations using room designations indicated.

1.3 INFORMATIONAL SUBMITTALS

A. Sample Warranty: For manufacturer's special warranties.

1.4 CLOSEOUT SUBMITTALS

A. Maintenance Data: For accessories to include in maintenance manuals.

1.5 WARRANTY

A. Manufacturer's Special Warranty for Mirrors: Manufacturer agrees to repair or replace mirrors that fail in materials or workmanship within specified warranty period.

1. Failures include, but are not limited to, visible silver spoilage defects.
2. Warranty Period: 10 years from date of Substantial Completion.

- B. Manufacturer's Special Warranty for Toilet-Compartment Occupancy-Indicator Systems: Manufacturer agrees to repair or replace toilet-compartment occupancy-indicator systems that fail in materials or workmanship within specified warranty period.
 - 1. Warranty Period: Five years from date of Substantial Completion.
- C. Manufacturer's Special Warranty for Hand Dryers: Manufacturer agrees to repair or replace hand dryers that fail in materials or workmanship within specified warranty period.
 - 1. Warranty Period: 10 years from date of Substantial Completion.

PART 2 - PRODUCTS

2.1 PERFORMANCE REQUIREMENTS

- A. Electrical Components, Devices, and Accessories: Listed and labeled as defined in NFPA 70, by a qualified testing agency, and marked for intended location and application.
- B. Structural Performance: Design accessories and fasteners to comply with the following requirements:
 - 1. Grab Bars: Installed units are able to resist **250 lbf** concentrated load applied in any direction and at any point.
 - 2. Shower Seats: Installed units are able to resist **250 lbf** concentrated load applied in any direction and at any point.

2.2 PUBLIC-USE WASHROOM ACCESSORIES

2.3 MATERIALS

- A. Stainless Steel: ASTM A240/A240M or ASTM A666, Type 304, **0.031-inch**- minimum nominal thickness unless otherwise indicated.
- B. Brass: ASTM B19, flat products; ASTM B16/B16M, rods, shapes, forgings, and flat products with finished edges; or ASTM B30, castings.
- C. Steel Sheet: ASTM A1008/A1008M, Designation CS (cold rolled, commercial steel), **0.036-inch**- minimum nominal thickness.
- D. Galvanized-Steel Sheet: ASTM A653/A653M, with **G60** hot-dip zinc coating.
- E. Galvanized-Steel Mounting Devices: ASTM A153/A153M, hot-dip galvanized after fabrication.
- F. Fasteners: Screws, bolts, and other devices of same material as accessory unit, unless otherwise recommended by manufacturer or specified in this Section, and tamper and theft resistant where exposed, and of stainless or galvanized steel where concealed.

- G. Chrome Plating: ASTM B456, Service Condition Number SC 2 (moderate service).
- H. Mirrors: ASTM C1503, Mirror Glazing Quality, clear-glass mirrors, nominal 6.0 mm thick.

2.4 FABRICATION

- A. General: Fabricate units with tight seams and joints, and exposed edges rolled. Hang doors and access panels with full-length, continuous hinges. Equip units for concealed anchorage and with corrosion-resistant backing plates.
- B. Keys: Provide universal keys for internal access to accessories for servicing and resupplying. Provide minimum of six keys to Owner's representative.

PART 3 - EXECUTION

3.1 INSTALLATION OF TOILET, BATH, AND LAUNDRY ACCESSORIES

- A. Install accessories in accordance with manufacturers' written instructions, using fasteners appropriate to substrate indicated and recommended by unit manufacturer. Install units level, plumb, and firmly anchored in locations and at heights indicated.
 - 1. Remove temporary labels and protective coatings.
- B. Grab Bars: Install to comply with specified structural-performance requirements.
- C. Shower Seats: Install to comply with specified structural-performance requirements.

END OF SECTION 102800

SECTION 102819 - TUB AND SHOWER ENCLOSURES

PART 1 - GENERAL

1.1 SUMMARY

- A. Section Includes:
 - 1. Frameless shower doors and enclosures.

1.2 ACTION SUBMITTALS

- A. Product Data: For each type of product.
 - 1. Include construction details, material descriptions, dimensions of individual components and profiles, and finishes for shower doors and enclosures.
- B. Shop Drawings: For tub and shower doors and enclosures.
 - 1. Include plans, elevations, sections, and attachment details.
- C. Samples for Initial Selection: For each type of exposed finish.

1.3 INFORMATIONAL SUBMITTALS

- A. Sample Warranty: For manufacturer's special warranty.

1.4 CLOSEOUT SUBMITTALS

- A. Maintenance Data: For tub and shower doors and enclosures to include in maintenance manuals.

1.5 FIELD CONDITIONS

- A. Verify dimensions by field measurements before fabrication and indicate on Shop Drawings.

1.6 WARRANTY

- A. Special Warranty: Manufacturer agrees to repair or replace components of tub and shower doors and enclosures that fail in materials or workmanship within specified warranty period, without monetary limitation.

1. Failures include, but are not limited to, the following:
 - a. Structural failures including excessive deflection.
 - b. Deterioration of metals, metal finishes, and other materials beyond normal use.
2. Warranty Period: Three years from date of Substantial Completion.

PART 2 - PRODUCTS

2.1 FRAMELESS ENCLOSURES

- A. Basis-of-Design Product: Subject to compliance with requirements, provide Aker; OPS-6030 AcrylX Alcove One-Piece Shower, includes ANSI grab bar and seat or Approved Equivalent product by one of the following:
 1. Alumax Bath Enclosures
 2. American Shower Door Corporation
 3. Anzzi; a brand of SWCorp
 4. Artistcraft Shower Doors
 5. Basco, Inc
 6. Century Bathworks
 7. Fleurco Products Inc.
 8. Hartung Glass Industries
 9. HMI
 10. PRL Glass Systems Inc.
 11. Seawin Hospitality; Seawin Global
 12. SouFlo
 13. Southeastern Aluminum Products, LLC
 14. VIGO Industries LLC
- B. Hardware and Trim: Manufacturer's standard units as indicated and as required for complete installation.
 1. Materials:
 - a. Aluminum:
 - 1) Finish: Clear anodic.
 - 2) Color: Silver.
 - b. Stainless Steel Sheet and Plate:
 - 1) Finish: ASTM A480/A480M No. 6 dull satin finish.
- C. Fasteners: Manufacturer's standard stainless steel or other noncorrosive fasteners.
- D. Sealant: Mildew-resistant, single-component, nonsag, neutral-curing silicone joint sealant; ASTM C920, Type S, Grade NS, Class 25, for Use NT.

E. Materials:

1. Aluminum: Alloy and temper recommended by manufacturer for type of use and finish indicated.
 - a. Sheet and Plate: **ASTM B209**.
 - b. Extrusions: **ASTM B221**.
2. Stainless Steel Sheet: ASTM A240/A240M or ASTM A666, Type 302 or 304.
3. Stainless Steel Bars and Shapes: ASTM A276/A276M, Type 302 or 304.
4. Copper-Alloy Sheet and Shapes: ASTM B36/B36M.
5. Copper-Alloy Extrusions: ASTM B455, alloy UNS No. C38500 (architectural brass).

PART 3 - EXECUTION

3.1 INSTALLATION

- A. Prepare and install per manufacturer's written instructions unless more stringent requirements are contained in NGA's "GANA Glazing Manual."
- B. Clean substrates, removing projections, filling voids, and sealing joints.
- C. Set units level, plumb, and true to line, without warp or rack of frames and panels, and anchor securely in place.
- D. Fasten components securely in place, with provisions for thermal movement. Install with concealed fasteners unless otherwise indicated.
- E. Install components to drain and return water to tub or shower.
- F. Install doors to produce smooth operation and tight fit at contact points.
- G. Repair, refinish, or replace components damaged during installation.

END OF SECTION 102819

SECTION 104413 - FIRE PROTECTION CABINETS

PART 1 - GENERAL

1.1 SUMMARY

A. Section Includes:

1. Fire-protection cabinets for the following:
 - a. Portable fire extinguisher.

B. Related Requirements:

1. Section 104416 "Fire Extinguishers" for portable, hand-carried fire extinguishers accommodated by fire-protection cabinets.

1.2 ACTION SUBMITTALS

A. Product Data: For each type of product.

B. Shop Drawings: For fire-protection cabinets.

1. Include plans, elevations, sections, details, and attachments to other work.

C. Samples: For each type of exposed finish required.

D. Product Schedule: For fire-protection cabinets. Indicate whether recessed, semirecessed, or surface mounted. Coordinate final fire-protection cabinet schedule with fire-extinguisher schedule to ensure proper fit and function.

1.3 CLOSEOUT SUBMITTALS

A. Maintenance Data: For fire-protection cabinets to include in maintenance manuals.

PART 2 - PRODUCTS

2.1 PERFORMANCE REQUIREMENTS

A. Fire-Rated Fire-Protection Cabinets: Listed and labeled to comply with requirements in ASTM E814 for fire-resistance rating of walls where they are installed.

B. Electrical Components, Devices, and Accessories: Listed and labeled as defined in NFPA 70, by a qualified testing agency, and marked for intended location and

application.

2.2 FIRE-PROTECTION CABINET

- A. Manufacturers: Subject to compliance with requirements, available manufacturers offering products that may be incorporated into the Work include, but are not limited to, the following:
1. Babcock-Davis
 2. Croker; a Division of Morris Group International
 3. Guardian Fire Equipment, Inc
 4. JL Industries; Activar Construction Products Group, Inc.
 5. Larsen's Manufacturing Company
 6. Modern Metal Products
 7. MOON American, Inc.
 8. Nystrom, Inc.
 9. Potter Roemer LLC; a Division of Morris Group International
 10. Strike First Corporation of America

2.3 FABRICATION

- A. Fire-Protection Cabinets: Provide manufacturer's standard box (tub) with trim, frame, door, and hardware to suit cabinet type, trim style, and door style indicated.
1. Weld joints and grind smooth.
 2. Miter corners and grind smooth.
 3. Provide factory-drilled mounting holes.
 4. Prepare doors and frames to receive locks.
 5. Install door locks at factory.
- B. Cabinet Doors: Fabricate doors according to manufacturer's standards, from materials indicated and coordinated with cabinet types and trim styles.
1. Fabricate door frames with tubular stiles and rails and hollow-metal design, minimum **1/2 inch** thick.
 2. Miter and weld perimeter door frames and grind smooth.
- C. Cabinet Trim: Fabricate cabinet trim in one piece with corners mitered, welded, and ground smooth.

2.4 GENERAL FINISH REQUIREMENTS

- A. Comply with NAAMM's AMP 500, "Metal Finishes Manual for Architectural and Metal Products," for recommendations for applying and designating finishes.
- B. Protect mechanical finishes on exposed surfaces of fire-protection cabinets from damage by applying a strippable, temporary protective covering before shipping.

- C. Finish fire-protection cabinets after assembly.
- D. Appearance of Finished Work: Noticeable variations in same piece are unacceptable. Variations in appearance of adjoining components are acceptable if they are within the range of approved Samples and are assembled or installed to minimize contrast.

PART 3 - EXECUTION

3.1 INSTALLATION OF FIRE-PROTECTION CABINETS

- A. General: Install fire-protection cabinets in locations and at mounting heights indicated or, if not indicated, at heights acceptable to authorities having jurisdiction.
 - 1. Fire-Protection Cabinet Mounting Height: **42 inches** above finished floor to top of fire extinguisher.
- B. Fire-Protection Cabinets: Fasten cabinets to structure, square and plumb.
 - 1. Unless otherwise indicated, provide recessed fire-protection cabinets. If wall thickness is inadequate for recessed cabinets, provide semirecessed fire-protection cabinets.
 - 2. Provide inside latch and lock for break-glass panels.
 - 3. Fasten mounting brackets to inside surface of fire-protection cabinets, square and plumb.
 - 4. Fire-Rated Cabinets:
 - a. Install cabinet with not more than **1/16-inch** tolerance between pipe OD and knockout OD. Center pipe within knockout.
 - b. Seal through penetrations with firestopping sealant as specified in Section 078413 "Penetration Firestopping."
- C. Identification:
 - 1. Apply **[decals][vinyl lettering]** at locations indicated.
 - 2. Apply decals on field-painted fire-protection cabinets after painting is complete.

END OF SECTION 104413

SECTION 104416 - FIRE EXTINGUISHERS

PART 1 - GENERAL

1.1 SUMMARY

- A. Section includes portable, fire extinguishers and mounting brackets for fire extinguishers.
- B. Owner-Furnished Material: fire extinguishers.
- C. Related Requirements:
 - 1. Section 104413 "Fire Protection Cabinets."

1.2 ACTION SUBMITTALS

- A. Product Data: For each type of product. Include rating and classification, material descriptions, dimensions of individual components and profiles, and finishes for fire extinguisher and mounting brackets.
- B. Product Schedule: For fire extinguishers. Coordinate final fire-extinguisher schedule with fire-protection cabinet schedule to ensure proper fit and function. Use same designations indicated on Drawings.

1.3 INFORMATIONAL SUBMITTALS

- A. Warranty: Sample of special warranty.

1.4 CLOSEOUT SUBMITTALS

- A. Operation and Maintenance Data: For fire extinguishers to include in maintenance manuals.

1.5 WARRANTY

- A. Special Warranty: Manufacturer's standard form in which manufacturer agrees to repair or replace fire extinguishers that fail in materials or workmanship within specified warranty period.
 - 1. Failures include, but are not limited to, the following:
 - a. Failure of hydrostatic test according to NFPA 10 when testing interval required by NFPA 10 is within the warranty period.

- b. Faulty operation of valves or release levers.
2. Warranty Period: Six years from date of Substantial Completion.

PART 2 - PRODUCTS

2.1 PERFORMANCE REQUIREMENTS

- A. NFPA Compliance: Fabricate and label fire extinguishers to comply with NFPA 10, "Portable Fire Extinguishers."
- B. Fire Extinguishers: Listed and labeled for type, rating, and classification by an independent testing agency acceptable to authorities having jurisdiction.

PART 3 - EXECUTION

3.1 INSTALLATION

- A. General: Install fire extinguishers and mounting brackets in locations indicated and in compliance with requirements of authorities having jurisdiction.
- B. Mounting Brackets: Fasten mounting brackets to surfaces, square and plumb, at locations indicated.
 - 1. Mounting Height: Top of fire extinguisher to be at **42 inches** above finished floor.

END OF SECTION 104416

SECTION 107313 - CANOPY

1. PART 1 - GENERAL

1. SUMMARY

A. Section Includes:

1. Fixed Canopy.

- a. Work in this section shall include design, fabrication, and installation of pre-engineered, pre-finished aluminum protective covers.

B. Related Requirements:

2. ACTION SUBMITTALS

A. Product Data: For each type of product.

1. Include styles, material descriptions, construction details, fabrication details, dimensions of individual components and profiles, hardware, fittings, mounting accessories, features, and finishes for awnings.
2. Include rated capacities, operating characteristics, electrical characteristics, and furnished specialties and accessories.

B. Shop Drawings:

1. Include plans, elevations, sections, mounting heights, and attachment details.
2. Detail fabrication and assembly of canopy.
3. Include diagrams for power, signal, and control wiring.
4. Show locations for blocking, reinforcement, and supplementary structural support.

C. Samples: For each exposed product and for each color and texture specified.

D. Product Schedule: For awnings. Use same designations indicated on Drawings.

3. INFORMATIONAL SUBMITTALS

A. Welding certificates.

B. Sample Warranty: For special warranty.

4. CLOSEOUT SUBMITTALS

- A. Operation and Maintenance Data: For awnings to include in operation and maintenance manuals.

5. QUALITY ASSURANCE

- A. Fabricator Qualifications: Shop that employs skilled workers who custom fabricate products similar to those required for this Project and whose products have a record of successful in-service performance.
- B. Manufacturer Qualifications: Minimum five years experience in design, fabrication, and production of aluminum protective covers.
- C. Welding Qualifications: Qualify procedures and personnel according to the following:
1. AWS D1.2/D1.2M, "Structural Welding Code - Aluminum."

2. PART 2 - PRODUCTS

1. PERFORMANCE REQUIREMENTS

- A. Thermal Movements: Allow for thermal movements from ambient and surface temperature changes.
1. Temperature Change: 120 deg F, ambient; 180 deg F, material surfaces.

2. AWNING FRAME AND ACCESSORY MATERIALS

- A. All framing fasteners shall be 300 series stainless steel with neoprene washers. All rivets are 3/16" aluminum. All decking fasteners shall be long life coated steel with a 300 series stainless steel cap and neoprene washer.

3. FIXED AWNINGS

- A. Basis-of-Design Product: Subject to compliance with requirements, provide Mitchell Metals; Aluminum Canopy Walkway Cover or Approved Equivalent
- B. Aluminum Finish: Factory applied baked enamel finish complying with finish manufacturer's written instructions for surface preparation including pretreatment, application, baking, and minimum dry film thickness.
1. Color: Confirm with Architect.
- C. Aluminum protective cover shall be mechanically fastened using internally welded brackets and concealed 300 series stainless steel fasteners. Welded connections can be used if shipping allows.

3. PART 3 - EXECUTION

1. INSTALLATION

- A. Canopies are to be installed according to approved shop drawings and plans.
- B. The entire structure shall be installed straight, true, plumb according to standard construction procedures.
- C. Canopies shall be installed with minimal slope to allow water flow from top of canopy to draining columns and eliminate ponding.
- D. Non-draining columns shall have weep holes installed at top of concrete to remove condensation from post. Minimum weep hole size shall be 1/4" in diameter.
- E. All joints, corners, and connection shall be tight and clean.
- F. All exposed fasteners to be painted to match the canopy color.
- G. Decking is to be aligned and secured to aluminum frame structure.

END OF SECTION 107313

SECTION 107516 - GROUND-SET FLAGPOLES

PART 1 - GENERAL

1.1 SUMMARY

- A. Section includes ground-set flagpoles made from aluminum.
- B. Owner-Furnished Material: Flags.

1.2 ACTION SUBMITTALS

PART 2 - PRODUCTS

2.1 PERFORMANCE REQUIREMENTS

- A. Structural Performance: Flagpole assemblies, including anchorages and supports, to withstand design loads indicated within limits and under conditions indicated.
 - 1. Wind Loads: Determine according to NAAMM FP 1001. Basic wind speed for Project location is 107 mph, with an exposure of C.
 - 2. Base flagpole design on flags of maximum standard size suitable for use with flagpole or flag size indicated, whichever is more stringent. Reuse existing flag and confirm material.

2.2 ALUMINUM FLAGPOLES

- A. Exposed Height: Verify existing pole height.

2.3 FITTINGS

PART 3 - EXECUTION

3.1 FLAGPOLE INSTALLATION

- A. General: Install flagpoles where indicated and according to Shop Drawings and manufacturer's written instructions.
- B. Foundation Tube: Place flagpole in tube, seated on bottom plate between steel centering wedges, and install hardwood wedges to secure flagpole in place. Place and compact sand in foundation tube and remove hardwood wedges. Seal top of

foundation tube with a **2-inch** layer of elastomeric joint sealant and cover with flashing collar.

- C. Baseplate: Cast anchor bolts in concrete foundation. Install baseplate on washers placed over leveling nuts on anchor bolts and adjust until flagpole is plumb. After flagpole is plumb, tighten retaining nuts and fill space under baseplate solidly with nonshrink, nonmetallic grout. Finish exposed grout surfaces smooth and slope 45 degrees away from edges of baseplate.

END OF SECTION 107516

SECTION 111200 - PARKING CONTROL EQUIPMENT

PART 1 - GENERAL

1.1 SUMMARY

A. Section Includes:

1. Vehicle detectors.

B. Related Requirements:

1. Section 281500 "Access Control Hardware Devices" for parking control equipment access devices.

1.2 ACTION SUBMITTALS

A. Product Data: For each type of product.

1. Include construction details, material descriptions, dimensions of individual components and profiles, and finishes for parking control equipment.
2. Include rated capacities, operating characteristics, electrical characteristics, and furnished specialties.

B. Shop Drawings: For parking control equipment.

1. Include plans, elevations, sections and attachment details.
2. Include details of equipment assemblies. Indicate dimensions, weights, loads, required clearances, method of field assembly, components, and location and size of each field connection.
3. Include diagrams for power, signal, and control wiring.
4. Vehicle Detectors: Layout and method of placement of vehicle loop detector system.

C. Samples: For each exposed product and for each color and texture specified, **6 inches** square in size.

1.3 INFORMATIONAL SUBMITTALS

A. Qualification Data: For Installer.

B. Field quality-control reports.

1.4 CLOSEOUT SUBMITTALS

- A. Operation and Maintenance Data: For parking control equipment to include in emergency, operation, and maintenance manuals.
- B. Software and Firmware Operational Documentation:
 - 1. Software operating and upgrade manuals.
 - 2. Program Software Backup: On USB media and approved online or cloud solution.
 - 3. Device address list.
 - 4. Printout of software application and graphic screens.

1.5 QUALITY ASSURANCE

- A. Installer Qualifications: An authorized representative who is trained and approved by manufacturer.

PART 2 - PRODUCTS

2.1 SYSTEM DESCRIPTION

- A. Parking Control System: For the following types of parking management:
 - 1. Flat-Rate Parking: Unlimited-duration parking, with free gate entry and fixed-fee amount paid while exiting.
 - 2. Parking Controls to be coordination with Owner.
- B. Electrical Components and Devices: Listed and labeled as defined in NFPA 70, by a qualified testing agency, and marked for intended location and application.

2.2 VEHICLE DETECTORS

- A. Vehicle Detectors: Provide detection devices that sense presence or transit of vehicles and emit signals activating gate-arm operators.
 - 1. Manufacturers: Subject to compliance with requirements, provide products by the following:
 - a. Assa Abloy; TransPort Traverse Classic
- B. Vehicle Loop Detector System: Self-tuning electronic presence detector with adjustable detection patterns, adjustable sensitivity and frequency settings, and panel indicator light. Include automatic closing timer with adjustable time delay before closing designed to hold gate arm open until traffic clears. Provide number of loops consisting of multiple strands of wire, number of turns, loop size, and method of placement at location indicated on Drawings, as recommended in writing by detection system

manufacturer for installation.

1. Field-Assembled Loop: Wire, in size indicated for field assembly.
2. Factory-Formed Loop: Wire, preformed in size indicated.
3. Operation:
 - a. Recognize vehicles within **6 inches** of each other on standard-sized loop.
 - b. Recognize vehicle direction by detecting vehicle moving from one loop to another.
 - c. Generate reverse count if vehicle backs up after generating directional count in forward direction.
 - d. Continuous diagnostic monitoring and memory for intermittently operating and failed loops.
 - 1) Needs to be confirmed with Owner.
 - e. Crosstalk test between adjacent loops.
- C. Active Infrared Vehicle Detector: Retroreflective Emitter/receiver-type presence detector with adjustable detection zone pattern and sensitivity, designed to detect the presence or transit of vehicle in gate-arm pathway by interrupting infrared beam in zone pattern and to emit signal activating gate-arm operator. Include automatic closing timer with adjustable time delay before closing, timer cut-off switch, and vehicle presence detector designed to hold gate arm open until traffic clears.

PART 3 - EXECUTION

3.1 INSTALLATION, GENERAL

- A. Install parking control equipment as required for complete and integrated installation.
 1. Rough-in electrical connections.

3.2 INSTALLATION OF AUTOMATIC BARRIER GATES

- A. Anchor cabinets to concrete bases with anchor bolts or expansion anchors, and mount barrier gate arms.
 1. Install barrier gates according to UL 325.

3.3 INSTALLATION OF VEHICLE DETECTORS

- A. Bury and seal wire loop at locations indicated on Drawings according to manufacturer's written instructions. Connect to parking control equipment operated by detector.

3.4 INSTALLATION OF TRAFFIC CONTROLLERS

- A. Anchor controllers to recessed concrete bases driveway surfaces with anchor bolts or expansion anchors.

3.5 INSTALLATION OF ENTRY TERMINALS

- A. Attach cabinets to concrete bases with anchor bolts or expansion anchors.

1. Connect equipment to remote computer.
2. Load ticket dispenser with supply of tickets.

3.6 INSTALLATION OF EXIT TERMINALS

- A. Attach cabinets to concrete bases with anchor bolts or expansion anchors.

1. Connect equipment to remote computer.
2. Load ticket dispenser with supply of tickets.

3.7 INSTALLATION OF PAY STATIONS

- A. Attach cabinets to concrete bases with anchor bolts or expansion anchors.

1. Connect equipment to remote computer.
2. Load ticket dispenser with supply of tickets.

3.8 INSTALLATION OF FEE COMPUTERS

- A. Install computers at locations indicated, including connecting to peripheral equipment and remote computers.

3.9 INSTALLATION OF CARD READER PEDESTALS

- A. Pad mount with mounting bolts.

3.10 INSTALLATION OF ELECTRICAL

- A. Connect wiring according to Section 260519 "Low-Voltage Electrical Power Conductors and Cables."
- B. Ground equipment according to Section 260526 "Grounding and Bonding for Electrical Systems."

3.11 FIELD QUALITY CONTROL

- A. Testing Agency: Owner will engage a qualified testing agency to perform tests and inspections.
- B. Perform the following tests and inspections:
 - 1. Perform each visual and mechanical inspection and electrical test stated in NETA ATS. Certify compliance with test parameters.
 - 2. Operational Test: After electrical circuitry has been energized, start units to confirm proper motor rotation and unit operation.
 - 3. Test and adjust controls and safeties. Replace damaged and malfunctioning controls and equipment.
- C. Parking control equipment will be considered defective if it does not pass tests and inspections.
- D. Prepare test and inspection reports.

3.12 MAINTENANCE SERVICE

- A. Maintenance Service Description: Beginning at Substantial Completion, maintenance service shall include 12 months' full maintenance by skilled employees of parking control equipment Installer. Include monthly preventive maintenance, repair or replacement of worn or defective components, lubrication, cleaning, and adjusting as required for proper parking control equipment operation. Parts and supplies shall be manufacturer's authorized replacement parts and supplies.
 - 1. Requirements to be coordinated with Owner.

3.13 DEMONSTRATION

- A. Train Owner's maintenance personnel to adjust, operate, and maintain parking control equipment.

END OF SECTION 111200

SECTION 122413 - ROLLER WINDOW SHADES

PART 1 - GENERAL

1.1 SUMMARY

A. Section Includes:

1. Manually operated, single-roller shades.

B. Related Requirements:

1. Section 057500 "Decorative Formed Metal" for shade pockets not provided by roller window shade manufacturer.
2. Section 061000 "Rough Carpentry" for wood blocking and grounds for mounting roller shades and accessories.
3. Section 079200 "Joint Sealants" for sealing the perimeters of installation accessories for light-blocking shades with a sealant.

1.2 ACTION SUBMITTALS

A. Product Data:

1. For each type of product.
 - a. Include construction details, material descriptions, dimensions of individual components and profiles, and finishes.
 - b. Include rated capacities, operating characteristics, features, and furnished accessories.

B. Shop Drawings:

1. Show fabrication and installation details for roller shades, including shadeband materials, their orientation to rollers, and their seam and batten locations.

C. Samples for Initial Selection: Manufacturer's standard color sheets, showing full range of available colors for each type and color of shadeband material and for each type of exposed finish.

1. Include Samples of accessories involving color selection.

D. Product Schedule: For roller shades.

1.3 INFORMATIONAL SUBMITTALS

A. Product Certificates: For each type of shadeband material.

- B. Product Test Reports: For each type of shadeband material, for tests performed by a qualified testing agency.
- C. Qualification Statements: For Installer.

1.4 CLOSEOUT SUBMITTALS

- A. Operation and Maintenance Data: For roller shades.

1.5 MAINTENANCE MATERIAL SUBMITTALS

- A. Extra Stock Material: Furnish extra materials, from the same production run, to Owner that match products installed and that are packaged with protective covering for storage and identified with labels describing contents.
 - 1. Roller Shades: Full-size units equal to 3 percent of quantity installed for each size, color, and shadeband material indicated, but no fewer than two units. Include mounting accessories.

1.6 QUALITY ASSURANCE

- A. Installer Qualifications: Fabricator of products.

1.7 DELIVERY, STORAGE, AND HANDLING

- A. Deliver roller shades in factory packages, marked with manufacturer, product name, and location of installation using same designations indicated on Drawings.

1.8 FIELD CONDITIONS

- A. Environmental Limitations: Do not install roller shades until construction and finish work in spaces, including painting, is complete and dry and ambient temperature and humidity conditions are maintained at the levels indicated for Project when occupied for its intended use.
- B. Field Measurements: Where roller shades are indicated to fit to other construction, verify dimensions of other construction by field measurements before fabrication and indicate measurements on Shop Drawings. Allow clearances for operating hardware of operable glazed units through entire operating range. Notify Architect of installation conditions that vary from Drawings. Coordinate fabrication schedule with construction progress to avoid delaying the Work.

1.9 WARRANTY

- A. Special Warranty: Manufacturer agrees to repair or replace components of products

that fail in materials or workmanship within specified warranty period.

1. Failures include, but are not limited to, the following:
 - a. Defects in materials and workmanship beyond normal wear and tear.
 - b. Faulty operation of operating system components.
 - c. Deterioration of fabric beyond normal use.
2. Warranty Period:
 - a. Roller Window Shades: Limited Lifetime year(s) from date of Substantial Completion.
 - b. Fabric: Five year(s) from date of Substantial Completion.

PART 2 - PRODUCTS

2.1 SOURCE LIMITATIONS

- A. Obtain roller shades from single source from single manufacturer.

2.2 PERFORMANCE REQUIREMENTS

- A. Fire Performance: Tested in accordance with and meeting the flame propagation performance criteria of Test 1 or Test 2, as appropriate, of NFPA 701; testing by a qualified testing agency. Identify products with appropriate markings of applicable testing agency.
- B. Accessibility Standards: Comply with applicable provisions in ICC A117.1 for roller window shades designated as accessible.

2.3 MANUALLY OPERATED ROLLER WINDOW SHADES

- A. Manually Operated, Single-Roller Shades (RS-1): For interior use in rectangular openings.
 1. Basis-of-Design Product: Subject to compliance with requirements, provide Hunter Douglas; RB500 Manual Roller Shades with Fascia Fabric or Approved Equivalent by one of the following:
 - a. BTX Intelligent Fashion, LLC
 - b. CACO, Inc.
 - c. DFB Sales, Inc.
 - d. Draper, Inc.
 - e. Insolroll Window Shading Systems
 - f. Lafayette Interior Fashions
 - g. Legrand Shading Systems; Legrand North America, LLC
 - h. Levolor Inc.

- i. Lutron Electronics Co., Inc
 - j. MechoShade Systems, LLC
 - k. Rollease Acmeda Inc.
 - l. Springs Window Fashions; SWFcontract
 2. Rollers: Corrosion-resistant steel or extruded-aluminum tubes of diameters and wall thicknesses required to accommodate operating mechanisms and weights and widths of shadebands indicated without deflection. Provide with permanently lubricated drive-end assemblies and idle-end assemblies designed to facilitate removal of shadebands for service.
 - a. Roller Drive-End Location: As indicated on Drawings.
 - b. Direction of Shadeband Roll: As indicated on Drawings.
 - c. Shadeband-to-Roller Attachment: Manufacturer's standard method.
 3. Shadebands:
 - a. Shadeband Material: .Sheerweave 2410 1% Openness
 4. Mounting Hardware: Brackets or endcaps, with endcap covers where exposed, corrosion resistant and compatible with roller assembly, operating mechanism, installation accessories, and installation location and conditions indicated.
 5. Installation Accessories:
 - a. Front Fascia: Aluminum extrusion that conceals front and underside of roller and shadeband assembly and attaches to roller endcaps without exposed fasteners. Inside mount.
 - b. Installation Accessories Color and Finish: As selected from manufacturer's full range.
- B. Manually Operated, Single-Roller Shades 2 (RS-2): For interior use in rectangular openings.
 1. Basis-of-Design Product: Subject to compliance with requirements, provide Hunter Douglas Architectural; Glacier Screen or Approved Equivalent by one of the following:
 - a. BTX Intelligent Fashion, LLC
 - b. CACO, Inc.
 - c. DFB Sales, Inc.
 - d. Draper, Inc.
 - e. Insolroll Window Shading Systems
 - f. Lafayette Interior Fashions
 - g. Legrand Shading Systems; Legrand North America, LLC
 - h. Levolor Inc.
 - i. Lutron Electronics Co., Inc
 - j. MechoShade Systems, LLC
 - k. Rollease Acmeda Inc.
 - l. Springs Window Fashions; SWFcontract
 2. Rollers: Corrosion-resistant steel or extruded-aluminum tubes of diameters and

wall thicknesses required to accommodate operating mechanisms and weights and widths of shadebands indicated without deflection. Provide with permanently lubricated drive-end assemblies and idle-end assemblies designed to facilitate removal of shadebands for service.

- a. Roller Drive-End Location: As indicated on Drawings.
 - b. Direction of Shadeband Roll: As indicated on Drawings.
 - c. Shadeband-to-Roller Attachment: Manufacturer's standard method.
3. Shadebands:
- a. Shadeband Material: .0% Openness
4. Mounting Hardware: Brackets or endcaps, with endcap covers where exposed, corrosion resistant and compatible with roller assembly, operating mechanism, installation accessories, and installation location and conditions indicated.
5. Installation Accessories:
- a. Front Fascia: Aluminum extrusion that conceals front and underside of roller and shadeband assembly and attaches to roller endcaps without exposed fasteners. Surface Mount.
 - b. Installation Accessories Color and Finish: As selected from manufacturer's full range.

2.4 MANUAL OPERATION

A. Manual Corded Operation:

1. Chain-and-Clutch Operating Mechanisms: With continuous-loop bead chain and clutch that stops shade movement when bead chain is released; permanently adjusted and lubricated.
 - a. Bead Chains: Manufacturer's standard bead chain with WCMA A100.1 compliant tension device installed on roller window shade by manufacturer and mounted on wall.
 - 1) Limit Stops: Provide upper and lower ball stops.

B. Manual Cordless Operation:

2.5 SHADEBAND MATERIALS

A. Light-Filtering Fabric: Woven fabric, stain and fade resistant.

1. Source: Roller shade manufacturer.
2. Type: 36% Fiberglass, 64% Vinyl on Fiberglass 100% Polyester with Acrylic Coated Backing.
3. Weave: Basketweave.
4. Thickness: 0.024".

5. Weight: 16.2/sq. y.
6. Roll Width: Per Drawings.
7. Orientation on Shadeband: As indicated on Drawings.
8. Openness Factor: 1 percent.
9. Color: Charcoal/Gray.

B. Light-Blocking Fabric: Opaque fabric, stain and fade resistant.

1. Source: Roller shade manufacturer.
2. Type: 100% Polyester with Acrylic Coated Backing.
3. Thickness: 0.014".
4. Weight: 11.79 oz./sq. yd..
5. Roll Width: Per Drawings.
6. Orientation on Shadeband: As indicated on Drawings.
7. Color: Charcoal/Gray.

2.6 FABRICATION OF ROLLER WINDOW SHADES

A. Unit Sizes: Fabricate units in sizes to fill window and other openings as follows, measured at **74 deg F**:

1. Between (Inside) Jamb Installation: Width equal to jamb-to-jamb dimension of opening in which shade is installed less **1/4 inch** per side or **1/2-inch** total, plus or minus **1/8 inch**. Length equal to head-to-sill or -floor dimension of opening in which shade is installed less **1/4 inch**, plus or minus **1/8 inch**.
2. Outside of Jamb Installation: Width and length as indicated on Drawings, with terminations between shades of end-to-end installations at centerlines of mullion or other defined vertical separations between openings.

B. Shadeband Fabrication: Fabricate shadebands without battens or seams to extent possible, except as follows:

1. Vertical Shades: Where width-to-length ratio of shadeband is equal to or greater than 1:4, provide battens and seams at uniform spacings along shadeband length to ensure shadeband tracking and alignment through its full range of movement without distortion of the material.

PART 3 - EXECUTION

3.1 EXAMINATION

- A. Examine substrates, areas, and conditions, with Installer present, for compliance with requirements for installation tolerances, operational clearances, and other conditions affecting performance of the Work.
- B. Proceed with installation only after unsatisfactory conditions have been corrected.

3.2 INSTALLATION OF ROLLER WINDOW SHADES

- A. Install roller shades level, plumb, aligned and centered on openings, and aligned with adjacent units in accordance with manufacturer's written instructions.
 - 1. Located so shadeband is not closer than **2 inches** to interior face of glass. Allow clearances for window operation hardware.
- B. Roller Shade Locations: As indicated on Drawings.

3.3 ADJUSTING

- A. Adjust and balance roller window shades to operate smoothly, easily, safely, and free from binding or malfunction through full operational range.

3.4 CLEANING AND PROTECTION

- A. Clean roller window shade surfaces, after installation, in accordance with manufacturer's written instructions.
- B. Provide final protection and maintain conditions, in a manner acceptable to manufacturer and Installer, that ensure that roller window shades are without damage or deterioration at time of Substantial Completion.
- C. Replace damaged roller shades that cannot be repaired, in a manner approved by Architect, before time of Substantial Completion.

3.5 DEMONSTRATION

- A. Engage a factory-authorized service representative to train Owner's maintenance personnel to adjust, operate, and maintain motor-operated roller window shades.

END OF SECTION 122413

SECTION 123616 - METAL COUNTERTOPS

PART 1 - GENERAL

1.1 SUMMARY

- A. Section Includes:
 - 1. Stainless-steel countertops.

1.2 ACTION SUBMITTALS

- A. Product Data: For each type of product.
- B. Shop Drawings: For metal fabrications.
 - 1. Include plans, sections, details, and attachments to other work. Detail fabrication and installation, including field joints.
 - 2. For countertops, show locations and sizes of cutouts and holes for items installed in metal countertops.

1.3 DELIVERY, STORAGE, AND HANDLING

- A. Deliver products only after casework and supports on which they will be installed has been completed in installation areas.
- B. Keep finished surfaces of products covered with polyethylene film or other protective covering during handling and installation.

1.4 FIELD CONDITIONS

- A. Field Measurements: Where products are indicated to fit to other construction, verify dimensions of other construction by field measurements before fabrication, and indicate measurements on Shop Drawings. Coordinate fabrication schedule with construction progress to avoid delaying the Work.

PART 2 - PRODUCTS

2.1 STAINLESS-STEEL FABRICATIONS

- A. Countertops: Fabricate from **0.062-inch**-thick, stainless-steel sheet. Provide smooth, clean exposed tops and edges in uniform plane, free of defects. Provide front and end overhang of **1 inch** over the base cabinets.

1. Joints: Fabricate countertops without field-made joints.
2. Weld shop-made joints.
3. Sound deaden the undersurface with heavy-build mastic coating.
4. Extend the top down to provide a **1-inch**- thick edge with a **1/2-inch** return flange.
5. Form the backsplash coved to and integral with top surface, with a **1/2-inch**- thick top edge and **1/2-inch** return flange.
6. Provide raised (marine) edge around perimeter of tops containing sinks; pitch tops containing sinks two ways to provide drainage without channeling or grooving.

2.2 MATERIALS

- A. Stainless-Steel Sheet: ASTM A240/A240M, Type 304.
- B. Sealant for Countertops: Manufacturer's standard sealant that complies with applicable requirements in Section 079200 "Joint Sealants" and the following:
 1. Mildew-Resistant Joint Sealant: Mildew resistant, single component, nonsag, neutral curing, silicone.
 2. Joint Sealant: Single component, nonsag, neutral curing, silicone; Class 25.
 3. Color: Clear.

2.3 STAINLESS-STEEL FINISH

- A. Grind and polish surfaces to produce uniform, directional satin finish matching No. 4 finish, with no evidence of welds and free of cross scratches. Run grain with long dimension of each piece. When polishing is completed, passivate and rinse surfaces. Remove embedded foreign matter and leave surfaces clean.

PART 3 - EXECUTION

3.1 EXAMINATION

- A. Examine areas, with Installer present, for compliance with requirements for installation tolerances and other conditions affecting performance of products.

3.2 INSTALLATION

- A. Install metal countertops level, plumb, and true; shim as required, using concealed shims.
- B. Field Jointing: Where possible, make field jointing in the same manner as shop jointing; use fasteners recommended by manufacturer. Prepare edges to be joined in shop so Project-site processing of top and edge surfaces is not required. Locate field joints where shown on Shop Drawings.

- C. Secure countertops to cabinets with Z- or L-type fasteners or equivalent; use two or more fasteners at each front, end, and back.
- D. Abut top and edge surfaces in one true plane, with internal supports placed to prevent deflection.
- E. Seal junctures of countertops, splashes, and walls with sealant for countertops.

3.3 CLEANING AND PROTECTION

- A. Repair or remove and replace defective work as directed on completion of installation.
- B. Clean finished surfaces. Remove and replace damaged products or touch up and refinish damaged areas to match original factory finish, as approved by Architect.
- C. Protection: Provide **6-mil** plastic or other suitable water-resistant covering over countertop surfaces. Tape to underside of countertop at a minimum of **48 inches** o.c. Remove protection at Substantial Completion.

END OF SECTION 123616

SECTION 123623.13 - PLASTIC-LAMINATE-CLAD COUNTERTOPS

PART 1 - GENERAL

1.1 SUMMARY

A. Section Includes:

1. Plastic-laminate-clad countertops.

B. Related Requirements:

1. Section 055000 "Metal Fabrications" for cantilever supports.

1.2 ACTION SUBMITTALS

A. Product Data: For each type of product.

1. Include data for fire-retardant treatment from chemical-treatment manufacturer and certification by treating plant that treated materials comply with requirements.

B. Shop Drawings:

1. Plans, sections, details, edge and backsplash profiles, and attachments to other work.
2. Locations and details of joints.
3. Locations and sizes of cutouts and holes for items installed in countertop.

C. Samples for Verification:

1. Plastic Laminates: For each type, color, pattern, and surface finish required, **8 by 10 inches** in size.

1.3 INFORMATIONAL SUBMITTALS

- A. Coordination Drawings: Indicate locations and sizes of cutouts and holes for items installed in countertop and backsplashes.

1.4 QUALITY ASSURANCE

- A. Fabricator Qualifications: Shop that employs skilled workers who custom fabricate products similar to those required for this Project and whose products have a record of successful in-service performance.

- B. Installer Qualifications: Fabricator of products.

PART 2 - PRODUCTS

2.1 PLASTIC-LAMINATE-CLAD COUNTERTOPS

- A. Plastic-Laminate-Clad Countertop Type :
- B. Quality Standard: Unless otherwise indicated, comply with ANSI/AWI 1236 for grades of plastic-laminate-clad countertops indicated for construction, finishes, installation, and other requirements.
 - 1. Provide inspections of fabrication and installation together with labels and certificates from AWI certification program indicating that countertops comply with requirements of grade specified.
 - 2. The Contract Documents contain requirements that are more stringent than that of the referenced quality standard. Comply with requirements of the Contract Documents in addition to those of referenced quality standard.
- C. Grade: Custom.
 - 1. Product Certificates: For indigenous materials, indicating location of material manufacturer and point of extraction, harvest, or recovery for each raw material. Include distance to Project, means of transportation, and cost for each indigenous material.
- D. High-Pressure Decorative Laminate (LAM-1) (LAM-1): ISO 4586-3,Grade HGS.
 - 1. Basis-of-Design Product: Subject to compliance with requirements, provide Wilsonart or Approved Equivalent by one of the following:
 - a. ABET Inc.
 - b. Formica Corporation
 - c. Laminart LLC
 - d. Nevamar Company, LLC
 - e. Pionite; a Panolam Industries International, Inc. brand
 - 2. Style: Premium Laminate
 - 3. Color: 8232K-05 Continental Walnut
- E. High-Pressure Decorative Laminate 2 (LAM-2): ISO 4586-3,Grade HGS.
 - 1. Basis-of-Design Product: Subject to compliance with requirements, provide Wilsonart or Approved Equivalent by one of the following:
 - a. ABET Inc.
 - b. Formica Corporation
 - c. Laminart LLC
 - d. Nevamar Company, LLC
 - e. Pionite; a Panolam Industries International, Inc. brand
 - 2. Style: Premium Laminate

3. Color: Magnolia 5012K-38 Textured Gloss
- F. High-Pressure Decorative Laminate 3 (LAM-3): ISO 4586-3, Grade HGS.
1. Basis-of-Design Product: Subject to compliance with requirements, provide Wilsonart or comparable product by one of the following:
 - a. ABET Inc.
 - b. Formica Corporation
 - c. Laminart LLC
 - d. Nevamar Company, LLC
 - e. Pionite; a Panolam Industries International, Inc. brand
 2. Style: Premium Laminate
 3. Color: 7981K-12 Landmark Wood, Softgrain
- G. High-Pressure Decorative Laminate 4 (LAM-4): ISO 4586-3, Grade HGS.
1. Basis-of-Design Product: Subject to compliance with requirements, provide Wilsonart or comparable product by one of the following:
 - a. ABET Inc.
 - b. Formica Corporation
 - c. Laminart LLC
 - d. Nevamar Company, LLC
 - e. Pionite; a Panolam Industries International, Inc. brand
 2. Style: Standard Laminate
 3. Color: Norwegian Ash 8241-38 Fine Velvet Finish
- H. High-Pressure Decorative Laminate 5 (LAM-5): ISO 4586-3, Grade HGS.
1. Basis-of-Design Product: Subject to compliance with requirements, provide Wilsonart or Approved Equivalent by one of the following:
 - a. ABET Inc.
 - b. Formica Corporation
 - c. Nevamar Company, LLC
 - d. Pionite; a Panolam Industries International, Inc. brand
 2. Style: HD Laminate
 3. Color: To Match Existing Casework in Report Room
- I. High-Pressure Decorative Laminate 6 (LAM-6): ISO 4586-3, Grade HGS.
1. Basis-of-Design Product: Subject to compliance with requirements, provide Wilsonart or Approved Equivalent by one of the following:
 - a. ABET Inc.
 - b. Formica Corporation
 - c. Laminart LLC

- d. Nevamar Company, LLC
 - e. Pionite; a Panolam Industries International, Inc. brand
- 2. Style: Standard Laminate
 - 3. Color: Slate Grey D91-60 Matte Finish
- J. High-Pressure Decorative Laminate 7 (LAM-7): ISO 4586-3, Grade HGS.
- 1. Basis-of-Design Product: Subject to compliance with requirements, provide Wilsonart or Approved Equivalent by one of the following:
 - a. ABET Inc.
 - b. Formica Corporation
 - c. Laminart LLC
 - d. Nevamar Company, LLC
 - e. Pionite; a Panolam Industries International, Inc. brand
 - 2. Style: Standard Laminate
 - 3. Color: See Schedule
- K. Colors, Patterns, and Finishes: Provide materials and products that result in colors and textures of exposed laminate surfaces complying with the following requirements:
- 1. As indicated by manufacturer's designations.
 - 2. Match Architect's sample.
- L. Edge Treatment: Same as laminate cladding on horizontal surfaces.
- M. Core Material: As selected by fabricator to comply with quality standard.
- N. Core Thickness: **3/4 inch**.
- 1. Build up countertop thickness to **1-1/2 inches** at front, back, and ends with additional layers of core material laminated to top.
- O. Paper Backing: Provide paper backing on underside of countertop substrate.

2.2 WOOD MATERIALS

- A. Wood Products: Provide materials that comply with requirements of referenced quality standard unless otherwise indicated.
- B. Composite Panel Products: Provide materials that comply with requirements of referenced quality standard for each type of countertop and quality grade specified unless otherwise indicated.
 - 1. Medium-Density Fiberboard (MDF): ANSI A208.2, MR 50.
 - a. Grade 130 or better; complying with performance requirements specified.

2. Particleboard: ANSI A208.1, MR 10.
 - a. Grade M-2 or better; complying with performance requirements specified.
3. Veneer-Core Hardwood Plywood: ANSI/HPVA HP-1.

2.3 FIRE-RETARDANT-TREATED MATERIALS

- A. Fire-Retardant-Treated Materials, General: Where fire-retardant-treated materials are indicated, use materials that are acceptable to authorities having jurisdiction and with fire-test-response characteristics specified as determined by testing identical products in accordance with test method indicated by a qualified testing agency.
 1. Use treated materials that comply with requirements of referenced quality standard. Do not use materials that are warped, discolored, or otherwise defective.
 2. Use fire-retardant-treatment formulations that do not bleed through or otherwise adversely affect finishes. Do not use colorants to distinguish treated materials from untreated materials.
 3. Identify fire-retardant-treated materials with appropriate classification marking of qualified testing agency in the form of removable paper label or imprint on surfaces that will be concealed from view after installation.

2.4 MISCELLANEOUS MATERIALS

- A. Adhesive for Bonding Plastic Laminate: Type I, waterproof type as selected by fabricator to comply with requirements.
 1. Adhesive for Bonding Edges: Hot-melt adhesive or adhesive specified above for faces.
- B. Installation Adhesive: Manufacturer's standard product that is recommended for application indicated.

2.5 FABRICATION

- A. Fabricate countertops to dimensions, profiles, and details indicated. Provide front and end overhang of **1 inch** over base cabinets. Ease edges to radius indicated for the following:
 1. Solid-Wood (Lumber) Members: **1/16 inch** unless otherwise indicated.
- B. Complete fabrication, including assembly, to maximum extent possible before shipment to Project site. Disassemble components only as necessary for shipment and installation. Where necessary for fitting at site, provide ample allowance for scribing, trimming, and fitting.
- C. Shop cut openings to maximum extent possible to receive appliances, plumbing

fixtures, electrical work, and similar items. Locate openings accurately, and use templates or roughing-in diagrams to produce accurately sized and shaped openings. Sand edges of cutouts to remove splinters and burrs.

1. Seal edges of cutouts by saturating with varnish.

PART 3 - EXECUTION

3.1 INSTALLATION OF PLASTIC-LAMINATE-CLAD COUNTERTOPS

- A. Grade: Install countertops to comply with same grade as item to be installed.
- B. Assemble countertops and complete fabrication at Project site to extent that it was not completed in the shop.
 1. Provide cutouts for appliances, plumbing fixtures, electrical work, and similar items. Locate openings accurately, and use templates or roughing-in diagrams to produce accurately sized and shaped openings. Sand edges of cutouts to remove splinters and burrs.
 2. Seal edges of cutouts by saturating with varnish.
- C. Field Jointing: Where possible, make in the same manner as shop jointing, using dowels, splines, adhesives, and fasteners recommended by manufacturer. Prepare edges to be joined in shop so Project-site processing of top and edge surfaces is not required. Locate field joints where indicated on Shop Drawings.
 1. Secure field joints in countertops with concealed clamping devices located within **6 inches** of front and back edges and at intervals not exceeding **24 inches**. Tighten in accordance with manufacturer's written instructions to exert a constant, heavy-clamping pressure at joints.
- D. Countertop Installation:
 1. Scribe and cut countertops to fit adjoining work, refinish cut surfaces, and repair damaged finish at cuts.
 2. Anchor securely by screwing through corner blocks of base cabinets or other supports into underside of countertop.
 3. Anchor wall cleating necessary for proper setting for countertops not supported by casework.
 4. Install countertops level and true in line. Use concealed shims as required to maintain not more than **1/8-inch-in-96-inch** variation from a straight, level plane.
 5. Secure backsplashes to tops with concealed metal brackets at **16 inches** o.c..
 6. Seal joints between countertop and backsplash, if any, and joints where countertop and backsplash abut walls with mildew-resistant silicone sealant or another permanently elastic sealing compound recommended by countertop material manufacturer.

3.2 ADJUSTING AND CLEANING

- A. Repair damaged and defective countertops, where possible, to eliminate functional and visual defects. Where impossible to repair, replace countertops. Adjust joinery for uniform appearance.
- B. Clean countertops on exposed and semiexposed surfaces.
- C. Protection: Provide kraft paper or other suitable covering over countertop surfaces, taped to underside of countertop at a minimum of **48 inches** o.c. Remove protection at Substantial Completion.

END OF SECTION 123623.13

SECTION 123661 - SIMULATED STONE COUNTERTOPS

PART 1 - GENERAL

1.1 SUMMARY

A. Section Includes:

1. Quartz agglomerate countertops.

B. Related Requirements:

1. Section 055000 "Metal Fabrications" for cantilever supports.
2. Section 224100 "Residential Plumbing Fixtures" and Section 224200 "Commercial Plumbing Fixtures" for non-integral sinks and plumbing fittings.

1.2 ACTION SUBMITTALS

A. Product Data: For each type of countertop material.

B. Shop Drawings:

1. Plans, sections, details, edge and backsplash profiles, and attachment to other work.
2. Locations and details of joints.
3. Locations, quantity, and type of supports/brackets.
4. Direction of directional pattern, if any.
5. Locations and sizes of cutouts and holes for items installed in countertop.
6. Apply AWI's Quality Certification WI's Certified Compliance Program label to Shop Drawings.

C. Samples for Initial Selection: For each type of material exposed to view.

D. Samples for Verification:

1. Countertop material, **6 inches** square.

1.3 INFORMATIONAL SUBMITTALS

A. Coordination Drawings: Indicate locations and sizes of cutouts and holes for items installed in countertops or backsplashes.

B. Qualification Statements: For fabricator.

1.4 CLOSEOUT SUBMITTALS

- A. Maintenance Data: For solid surface material countertops to include in maintenance manuals. Include product data for care products used or recommended by Installer and names, addresses, and telephone numbers of local sources for products.

1.5 QUALITY ASSURANCE

- A. Fabricator Qualifications: Shop that employs skilled workers who custom-fabricate countertops similar to that required for this Project, and whose products have a record of successful in-service performance.
- B. Installer Qualifications: Fabricator of countertops.

1.6 DELIVERY, STORAGE, AND HANDLING

- A. Deliver countertops only after casework and supports on which they will be installed have been completed in installation areas.
- B. Store countertops in areas where environmental conditions comply with requirements specified in "Field Conditions" Article.
- C. Keep surfaces of countertops covered with protective covering during handling and installation.

1.7 FIELD CONDITIONS

- A. Field Measurements: Where countertops are indicated to fit to other construction, verify dimensions of countertops by field measurements before countertop fabrication is complete and indicate measurements on Shop Drawings. Coordinate fabrication schedule with construction progress to avoid delaying the Work..

PART 2 - PRODUCTS

2.1 PERFORMANCE REQUIREMENTS

- A. Quality Standard: Unless otherwise indicated, comply with ANSI/AWI 1236 NAAWS for grades of simulated stone countertops indicated for construction, finishes, installation, and other requirements.
 - 1. Provide inspections of fabrication and installation together with labels and certificates from AWI certification program indicating that countertops comply with requirements of grade specified.
- B. Cultured Marble Countertop Type :

1. Grade: [Premium][Custom][Economy][Match related casework].

C. Solid Surface Countertop Type :

1. Grade: [Premium][Custom][Economy][Match related casework].

2.2 QUARTZ AGGLOMERATE COUNTERTOPS

A. Quartz Agglomerate Countertop Type :

1. Grade: Custom.

B. Quartz Agglomerate Material (SS-1): Homogenous fabrication of natural quartz aggregates and pigments bound together with a matrix of polymers and resins, complying with ISFA 3-01.

1. Basis-of-Design Product: Subject to compliance with requirements, provide Wilsonart or Approved Equivalent by one of the following:

- a. Cambria
- b. Cosentino North America; C&C North America, Inc.
- c. DuPont; DuPont de Nemours, Inc.
- d. Durasein Solid Surface; a brand of Relang International, LLC
- e. Lotte Chemical Co., LTD
- f. TechniStone; Wilsonart LLC
- g. Vicostone USA

2. Colors and Patterns: Quartz Select Terulinga Q6024.

3. Countertop:

- a. Thickness: 0.787 inch.
- b. Exposed Edge Treatment: Straight.
- c. Backsplash: Detached straight.

1) Height: .

4. Sink Bowls:

- a. Separate unit for under-counter mounting.
- b. Material: Stainless steel Vitreous china.
- c. Shape: Rectangle.

C. Quartz Agglomerate Material 2 (SS-2): Homogenous fabrication of natural quartz aggregates and pigments bound together with a matrix of polymers and resins, complying with ISFA 3-01.

1. Basis-of-Design Product: Subject to compliance with requirements, provide Wilsonart or Approved Equivalent by one of the following:

- a. Cambria

- b. Cosentino North America; C&C North America, Inc.
 - c. DuPont; DuPont de Nemours, Inc.
 - d. Durasein Solid Surface; a brand of Relang International, LLC
 - e. Lotte Chemical Co., LTD
 - f. TechniStone; Wilsonart LLC
 - g. Vicostone USA
2. Colors and Patterns: Quartz Select Urban Cloud Q6024.
 3. Countertop:
 - a. Thickness: **0.787 inch**.
 - b. Exposed Edge Treatment: Per Finish Schedule.
 4. Sink Bowls:
 - a. Separate unit for under-counter mounting.
 - b. Material: Stainless steel.
 - c. Shape: Rectangle.
 - d. Color: See Drawings.

2.3 ACCESSORIES

A. Support Brackets:

1. Countertop SS-1, SS-2:
 - a. Type: Decorative See Drawings.
 - b. Heavy-Duty brackets spaced 24 inches o.c. or as required.
 - c. Color: Black powder coat.

2.4 FABRICATION

- A. Fabricate countertops in sizes and shapes required to comply with requirements indicated.
- B. Fabricate tops with shop-applied edges unless otherwise indicated. Comply with solid surface material manufacturer's written instructions for adhesives, sealers, fabrication, and finishing.
 1. Fabricate with loose backsplashes for field assembly.
- C. Joints:
 1. Fabricate countertops without joints.
 2. Fabricate countertops in sections for joining in field, with joints at locations indicated.
 - a. Joint Locations: Not within **18 inches** of a sink or cooktop and not where a countertop section less than **36 inches** long would result, unless

unavoidable.

D. Cutouts and Holes:

1. Undercounter Plumbing Fixtures: Make cutouts for fixtures in shop using template or pattern furnished by fixture manufacturer. Form cutouts to smooth, even curves.
 - a. Provide vertical edges, slightly eased at juncture of cutout edges with top and bottom surfaces of countertop and projecting **3/16 inch** into fixture opening.
 - b. Provide vertical edges, rounded to **3/8-inch** radius at juncture of cutout edges with top surface of countertop, slightly eased at bottom, and projecting **3/16 inch** into fixture opening.
 - c. Provide **3/4-inch** full bullnose edges projecting **3/8 inch** into fixture opening.
2. Counter-Mounted Plumbing Fixtures: Prepare countertops in shop for field cutting openings for counter-mounted fixtures. Mark tops for cutouts and drill holes at corners of cutout locations. Make corner holes of largest radius practical.
3. Fittings: Drill countertops in shop for grommets, plumbing fittings, undercounter soap dispensers, and similar items.

2.5 INSTALLATION MATERIALS

- A. Particleboard: ANSI A208.1, Grade M-2.
- B. Plywood: Exterior softwood plywood complying with DOC PS 1, Grade C-C Plugged, touch sanded.
- C. Adhesive: Product recommended by manufacturer.
- D. Sealant for Countertops: Comply with applicable requirements in Section 079200 "Joint Sealants."

PART 3 - EXECUTION

3.1 EXAMINATION

- A. Examine substrates to receive countertops and conditions under which countertops will be installed, with Installer present, for compliance with requirements for installation tolerances and other conditions affecting performance of countertops.
- B. Proceed with installation only after unsatisfactory conditions have been corrected.

3.2 PREPARATION

- A. Before installation, condition countertops to average prevailing humidity conditions in

installation areas.

- B. Examine shop-fabricated work for completion and complete work as required, including removal of packing.

3.3 INSTALLATION OF SIMULATED STONE COUNTERTOPS

- A. Grade: Install countertops to comply with specified grade.
- B. Assemble countertops and complete fabrication at Project site to the extent that it was not completed in the shop.
- C. Countertop Installation:
 - 1. Scribe and cut countertops to fit adjoining work, refinish cut surfaces, and repair damaged finish at cuts.
 - 2. Anchor securely by screwing through corner blocks of base cabinets or other supports into underside of countertop.
 - 3. Anchor wall cleating necessary for proper setting for countertops not supported by casework.
 - 4. Install countertops level to a tolerance of **1/8 inch in 8 ft.**, **1/4 inch** maximum. Do not exceed **1/64-inch** difference between planes of adjacent units.
 - 5. Fasten countertops by screwing through corner blocks of base units into underside of countertop. Predrill holes for screws as recommended by manufacturer. Align adjacent surfaces and, using adhesive in color to match countertop, form seams to comply with quartz agglomerate manufacturer's written instructions. Carefully dress joints smooth, remove surface scratches, and clean entire surface.
 - 6. Bond joints with adhesive and draw tight as countertops are set. Mask areas of countertops adjacent to joints to prevent adhesive smears.
 - a. Install metal splines in kerfs in countertop edges at joints. Fill kerfs with adhesive before inserting splines and remove excess immediately after adjoining units are drawn into position.
 - b. Clamp units to temporary bracing, supports, or each other to ensure that countertops are properly aligned and joints are of specified width.
 - 7. Install backsplashes and end splashes by adhering to wall and countertops with adhesive. Mask areas of countertops and splashes adjacent to joints to prevent adhesive smears.
 - 8. Install aprons to backing and countertops with adhesive. Mask areas of countertops and splashes adjacent to joints to prevent adhesive smears. Fasten by screwing through backing. Predrill holes for screws as recommended by manufacturer.
 - 9. Seal joints between countertop and backsplash, if any, and joints where countertop and backsplash abut walls. Comply with Section 079200 "Joint Sealants."

3.4 ADJUSTING AND CLEANING

- A. Repair damaged and defective countertops, where possible, to eliminate functional and visual defects. Where not possible to repair, replace countertops. Adjust joinery for uniform appearance.
- B. Clean countertops on exposed and semi-exposed surfaces.
- C. Protection: Provide Kraft paper or other suitable covering over countertop surfaces, taped to underside of countertop at a minimum of **48 inches** o.c. Remove protection at Substantial Completion.

END OF SECTION 123661

SECTION 21 05 00 - COMMON WORK RESULTS FOR FIRE SUPPRESSION**PART 1 GENERAL****1.1 SECTION INCLUDES**

- A. Escutcheons.
- B. Expansions - hose and braid.
- C. Fire rated enclosures.
- D. Mechanical couplings.
- E. Pipe hangers and supports.
- F. Pipe sleeves.
- G. Pipe sleeve-seal systems.

1.2 RELATED REQUIREMENTS

- A. Section 21 13 00 - Fire-Suppression Sprinkler Systems: Sprinkler systems design.

1.3 REFERENCE STANDARDS

- A. ASME A112.18.1 - Plumbing Supply Fittings; 2024.
- B. ASME BPVC-IX - Boiler and Pressure Vessel Code, Section IX - Qualification Standard for Welding, Brazing, and Fusing Procedures; Welders; Brazers; and Welding, Brazing, and Fusing Operators; 2023, with Errata (2024).
- C. ASTM A536 - Standard Specification for Ductile Iron Castings; 2024.
- D. AWWA C606 - Grooved and Shouldered Joints; 2022.
- E. NFPA 13 - Standard for the Installation of Sprinkler Systems; Most Recent Edition Adopted by Authority Having Jurisdiction, Including All Applicable Amendments and Supplements.

1.4 SUBMITTALS

- A. See Section 01 30 00 - Administrative Requirements for submittal procedures.
- B. Product Data: Provide manufacturer's catalog information. Indicate valve data and ratings.
- C. Shop Drawings: Indicate pipe materials used, jointing methods, supports, and floor and wall penetration seals. Indicate installation, layout, weights, mounting and support details, and piping connections.

1.5 QUALITY ASSURANCE

- A. Manufacturer Qualifications: Company specializing in manufacturing the Products specified in this section with minimum three years documented experience.
- B. Installer Qualifications: Company specializing in performing work of the type specified in this section.

1. Approved by manufacturer.
- C. Products Requiring Electrical Connection: Listed and classified as suitable for the purpose specified and indicated.
- D. Clean equipment, pipes, valves, and fittings of grease, metal cuttings, and sludge that may have accumulated from the installation and testing of the system.

1.6 DELIVERY, STORAGE, AND HANDLING

- A. Deliver and store valves in shipping containers, with labeling in place.

1.7 WARRANTY

- A. See Section 01 78 00 - Closeout Submittals for additional warranty requirements.
- B. Correct defective Work within a five year period after Date of Substantial Completion.

PART 2 PRODUCTS

2.1 GENERAL REQUIREMENTS

- A. Sprinkler-based System:
 1. Comply with NFPA 13.
 2. See Section 21 13 00.
- B. Welding Materials and Procedures: Comply with ASME BPVC-IX.
- C. Provide system pipes, fittings, sleeves, escutcheons, seals, and other related accessories.

2.2 PIPE SLEEVES

- A. Vertical Piping:
 1. Sleeve Length: 1 inch above finished floor.
 2. Provide sealant for watertight joint.
- B. Pipe Passing Through Concrete Beam Flanges, except where Brass Pipe Sleeves are Specified:
 1. Galvanized steel pipe or black iron pipe with asphalt coating.
 2. Connect sleeve with floor plate except in mechanical rooms.
- C. Pipe Passing Through Mechanical, Laundry, and Animal Room Floors above Basement:
 1. Galvanized steel pipe or black iron pipe with asphalt coating.
 2. Connect sleeve with floor plate except in mechanical rooms.

2.3 PIPE SLEEVE-SEAL SYSTEMS

- A. Modular Mechanical Seals:
 1. Elastomer-based interlocking links to continuously fill annular space between pipe and wall-sleeve, wall or casing opening.
 2. Watertight seal between pipe and wall-sleeve, wall or casing opening.

3. Size and select seal component materials in accordance with service requirements.
 4. Service Requirements:
 - a. Underground, buried, and wet conditions.
 5. Glass-reinforced plastic pressure end plates.
- B. Wall Sleeve: PVC material with waterstop collar, and nailer end caps.
- C. Sleeve-Forming Disk: Nonconductive plastic-based material, 3 inch thick.
- D. Pipeline-Casing Seals:
1. End Seals: 1/8 inch, pull-on type, rubber or synthetic rubber based.
- 2.4 FIRE-RATED ENCLOSURES
- A. Provide as required to preserve fire resistance rating of building elements.
- 2.5 ESCUTCHEONS
- A. Material:
1. Metals and Finish: Comply with ASME A112.18.1.
- B. Construction:
1. One-piece for mounting on chrome-plated tubing or pipe and one-piece or split-pattern type elsewhere.
 2. Internal spring tension devices or setscrews to maintain a fixed position against a surface.
- 2.6 PIPE HANGERS AND SUPPORTS
- A. Hangers for Pipe Sizes 1/2 to 1-1/2 inch: Malleable iron, adjustable swivel, split ring.
- B. Hangers for Pipe Sizes 2 inches and Over: Carbon steel, adjustable, clevis.
- C. Multiple or Trapeze Hangers: Steel channels with welded spacers and hanger rods.
- D. Wall Support for Pipe Sizes 4 inches and Over: Welded steel bracket and wrought steel clamp.
- E. Vertical Support: Steel riser clamp.
- F. Floor Support: Cast iron adjustable pipe saddle, lock nut, nipple, floor flange, and concrete pier or steel support.
- 2.7 EXPANSION JOINTS AND LOOPS - HOSE AND BRAID
- A. Provide flexible loops with two flexible sections of hose and braid, two 90-degree elbows, and 180-degree return with support bracket and air release or drain plug.
- B. Provide flexible loops capable of movement in the x, y, and z planes. Flexible loops to impart no thrust loads to the building structure.
- C. Flexible Connectors: Flanged, braided type with wetted components of stainless steel, sized to match piping.
1. Maximum Allowable Working Pressure: 150 psig at 120 degrees F.

2. Accommodate the Following:
 - a. Axial Deflection in Compression and Expansion: _____ inch.
 - b. Lateral Movement: _____ inch.
 - c. Angular Rotation: 15 degrees.
 - d. Force developed by 1.5 times specified maximum allowable operating pressure.
3. Provide necessary accessories including, but not limited to, swivel joints.

2.8 MECHANICAL COUPLINGS

- A. Rigid Mechanical Couplings for Grooved Joints:
 1. Dimensions and Testing: Comply with AWWA C606.
 2. Minimum Working Pressure: 300 psig.
 3. Housing Material: Fabricate of ductile iron complying with ASTM A536.
 4. Housing Coating: Factory applied orange enamel.
 5. Gasket Material: EPDM suitable for operating temperature range from minus 30 degrees F to 230 degrees F.
 6. Bolts and Nuts: Hot-dipped-galvanized or zinc-electroplated steel.

PART 3 EXECUTION

3.1 PREPARATION

3.2 INSTALLATION

- A. Install sprinkler system and service main piping, hangers, and supports in accordance with NFPA 13.
- B. Route piping in orderly manner, plumb and parallel to building structure. Maintain gradient.
- C. Install piping to conserve building space, to not interfere with use of space and other work.
- D. Group piping whenever practical at common elevations.
- E. Install piping to allow for expansion and contraction without stressing pipe, joints, or connected equipment.
- F. Pipe Hangers and Supports:
 1. Install hangers to provide minimum 1/2 inch space between finished covering and adjacent work.
 2. Place hangers within 12 inches of each horizontal elbow.
 3. Use hangers with 1-1/2 inch minimum vertical adjustment. Design hangers for pipe movement without disengagement of supported pipe.
 4. Support vertical piping at every other floor. Support riser piping independently of connected horizontal piping.

5. Where several pipes can be installed in parallel and at same elevation, provide multiple or trapeze hangers.
- G. Slope piping and arrange systems to drain at low points. Use eccentric reducers to maintain top of pipe level.
- H. Prepare pipe, fittings, supports, and accessories for finish painting. Where pipe support members are welded to structural building framing, scrape, brush clean, and apply one coat of zinc-rich primer to welding.
- I. Provide sleeves when penetrating footings, floors, walls, and partitions. Seal pipe including sleeve penetrations to achieve fire resistance equivalent to fire separation required.
- J. Manufactured Sleeve-Seal Systems:
 1. Install manufactured sleeve-seal systems in sleeves located in grade slabs and exterior concrete walls at piping entrances into building.
 2. Provide sealing elements of the size, quantity, and type required for the piping and sleeve inner diameter or penetration diameter.
 3. Locate piping in center of sleeve or penetration.
 4. Install field assembled sleeve-seal system components in annular space between sleeve and piping.
 5. Tighten bolting for a watertight seal.
 6. Install in accordance with manufacturer's recommendations.
- K. Escutcheons:
 1. Install and firmly attach escutcheons at piping penetrations into finished spaces.
 2. Provide escutcheons on both sides of partitions separating finished areas through which piping passes.
 3. Use chrome plated escutcheons in occupied spaces and to conceal openings in construction.
- L. When installing more than one piping system material, ensure system components are compatible and joined to ensure the integrity of the system. Provide necessary joining fittings. Ensure flanges, unions, and couplings for servicing are consistently provided.

END OF SECTION

SECTION 123661 - SIMULATED STONE COUNTERTOPS

PART 1 - GENERAL

1.1 SUMMARY

A. Section Includes:

1. Quartz agglomerate countertops.

B. Related Requirements:

1. Section 055000 "Metal Fabrications" for cantilever supports.
2. Section 224100 "Residential Plumbing Fixtures" and Section 224200 "Commercial Plumbing Fixtures" for non-integral sinks and plumbing fittings.

1.2 ACTION SUBMITTALS

A. Product Data: For each type of countertop material.

B. Shop Drawings:

1. Plans, sections, details, edge and backsplash profiles, and attachment to other work.
2. Locations and details of joints.
3. Locations, quantity, and type of supports/brackets.
4. Direction of directional pattern, if any.
5. Locations and sizes of cutouts and holes for items installed in countertop.
6. Apply AWI's Quality Certification WI's Certified Compliance Program label to Shop Drawings.

C. Samples for Initial Selection: For each type of material exposed to view.

D. Samples for Verification:

1. Countertop material, **6 inches** square.

1.3 INFORMATIONAL SUBMITTALS

A. Coordination Drawings: Indicate locations and sizes of cutouts and holes for items installed in countertops or backsplashes.

B. Qualification Statements: For fabricator.

1.4 CLOSEOUT SUBMITTALS

- A. Maintenance Data: For solid surface material countertops to include in maintenance manuals. Include product data for care products used or recommended by Installer and names, addresses, and telephone numbers of local sources for products.

1.5 QUALITY ASSURANCE

- A. Fabricator Qualifications: Shop that employs skilled workers who custom-fabricate countertops similar to that required for this Project, and whose products have a record of successful in-service performance.
- B. Installer Qualifications: Fabricator of countertops.

1.6 DELIVERY, STORAGE, AND HANDLING

- A. Deliver countertops only after casework and supports on which they will be installed have been completed in installation areas.
- B. Store countertops in areas where environmental conditions comply with requirements specified in "Field Conditions" Article.
- C. Keep surfaces of countertops covered with protective covering during handling and installation.

1.7 FIELD CONDITIONS

- A. Field Measurements: Where countertops are indicated to fit to other construction, verify dimensions of countertops by field measurements before countertop fabrication is complete and indicate measurements on Shop Drawings. Coordinate fabrication schedule with construction progress to avoid delaying the Work..

PART 2 - PRODUCTS

2.1 PERFORMANCE REQUIREMENTS

- A. Quality Standard: Unless otherwise indicated, comply with ANSI/AWI 1236 NAAWS for grades of simulated stone countertops indicated for construction, finishes, installation, and other requirements.
 - 1. Provide inspections of fabrication and installation together with labels and certificates from AWI certification program indicating that countertops comply with requirements of grade specified.
- B. Cultured Marble Countertop Type :

1. Grade: [Premium][Custom][Economy][Match related casework].

C. Solid Surface Countertop Type :

1. Grade: [Premium][Custom][Economy][Match related casework].

2.2 QUARTZ AGGLOMERATE COUNTERTOPS

A. Quartz Agglomerate Countertop Type :

1. Grade: Custom.

B. Quartz Agglomerate Material (SS-1): Homogenous fabrication of natural quartz aggregates and pigments bound together with a matrix of polymers and resins, complying with ISFA 3-01.

1. Basis-of-Design Product: Subject to compliance with requirements, provide Wilsonart or Approved Equivalent by one of the following:

- a. Cambria
- b. Cosentino North America; C&C North America, Inc.
- c. DuPont; DuPont de Nemours, Inc.
- d. Durasein Solid Surface; a brand of Relang International, LLC
- e. Lotte Chemical Co., LTD
- f. TechniStone; Wilsonart LLC
- g. Vicostone USA

2. Colors and Patterns: Quartz Select Terulinga Q6024.

3. Countertop:

- a. Thickness: 0.787 inch.
- b. Exposed Edge Treatment: Straight.
- c. Backsplash: Detached straight.

- 1) Height: .

4. Sink Bowls:

- a. Separate unit for under-counter mounting.
- b. Material: Stainless steel Vitreous china.
- c. Shape: Rectangle.

C. Quartz Agglomerate Material 2 (SS-2): Homogenous fabrication of natural quartz aggregates and pigments bound together with a matrix of polymers and resins, complying with ISFA 3-01.

1. Basis-of-Design Product: Subject to compliance with requirements, provide Wilsonart or Approved Equivalent by one of the following:

- a. Cambria

- b. Cosentino North America; C&C North America, Inc.
 - c. DuPont; DuPont de Nemours, Inc.
 - d. Durasein Solid Surface; a brand of Relang International, LLC
 - e. Lotte Chemical Co., LTD
 - f. TechniStone; Wilsonart LLC
 - g. Vicostone USA
2. Colors and Patterns: Quartz Select Urban Cloud Q6024.
3. Countertop:
- a. Thickness: **0.787 inch**.
 - b. Exposed Edge Treatment: Per Finish Schedule.
4. Sink Bowls:
- a. Separate unit for under-counter mounting.
 - b. Material: Stainless steel.
 - c. Shape: Rectangle.
 - d. Color: See Drawings.

2.3 ACCESSORIES

A. Support Brackets:

1. Countertop SS-1, SS-2:
- a. Type: Decorative See Drawings.
 - b. Heavy-Duty brackets spaced 24 inches o.c. or as required.
 - c. Color: Black powder coat.

2.4 FABRICATION

- A. Fabricate countertops in sizes and shapes required to comply with requirements indicated.
- B. Fabricate tops with shop-applied edges unless otherwise indicated. Comply with solid surface material manufacturer's written instructions for adhesives, sealers, fabrication, and finishing.
1. Fabricate with loose backsplashes for field assembly.
- C. Joints:
1. Fabricate countertops without joints.
2. Fabricate countertops in sections for joining in field, with joints at locations indicated.
- a. Joint Locations: Not within **18 inches** of a sink or cooktop and not where a countertop section less than **36 inches** long would result, unless

unavoidable.

D. Cutouts and Holes:

1. Undercounter Plumbing Fixtures: Make cutouts for fixtures in shop using template or pattern furnished by fixture manufacturer. Form cutouts to smooth, even curves.
 - a. Provide vertical edges, slightly eased at juncture of cutout edges with top and bottom surfaces of countertop and projecting **3/16 inch** into fixture opening.
 - b. Provide vertical edges, rounded to **3/8-inch** radius at juncture of cutout edges with top surface of countertop, slightly eased at bottom, and projecting **3/16 inch** into fixture opening.
 - c. Provide **3/4-inch** full bullnose edges projecting **3/8 inch** into fixture opening.
2. Counter-Mounted Plumbing Fixtures: Prepare countertops in shop for field cutting openings for counter-mounted fixtures. Mark tops for cutouts and drill holes at corners of cutout locations. Make corner holes of largest radius practical.
3. Fittings: Drill countertops in shop for grommets, plumbing fittings, undercounter soap dispensers, and similar items.

2.5 INSTALLATION MATERIALS

- A. Particleboard: ANSI A208.1, Grade M-2.
- B. Plywood: Exterior softwood plywood complying with DOC PS 1, Grade C-C Plugged, touch sanded.
- C. Adhesive: Product recommended by manufacturer.
- D. Sealant for Countertops: Comply with applicable requirements in Section 079200 "Joint Sealants."

PART 3 - EXECUTION

3.1 EXAMINATION

- A. Examine substrates to receive countertops and conditions under which countertops will be installed, with Installer present, for compliance with requirements for installation tolerances and other conditions affecting performance of countertops.
- B. Proceed with installation only after unsatisfactory conditions have been corrected.

3.2 PREPARATION

- A. Before installation, condition countertops to average prevailing humidity conditions in

installation areas.

- B. Examine shop-fabricated work for completion and complete work as required, including removal of packing.

3.3 INSTALLATION OF SIMULATED STONE COUNTERTOPS

- A. Grade: Install countertops to comply with specified grade.
- B. Assemble countertops and complete fabrication at Project site to the extent that it was not completed in the shop.
- C. Countertop Installation:
 - 1. Scribe and cut countertops to fit adjoining work, refinish cut surfaces, and repair damaged finish at cuts.
 - 2. Anchor securely by screwing through corner blocks of base cabinets or other supports into underside of countertop.
 - 3. Anchor wall cleating necessary for proper setting for countertops not supported by casework.
 - 4. Install countertops level to a tolerance of **1/8 inch in 8 ft., 1/4 inch** maximum. Do not exceed **1/64-inch** difference between planes of adjacent units.
 - 5. Fasten countertops by screwing through corner blocks of base units into underside of countertop. Predrill holes for screws as recommended by manufacturer. Align adjacent surfaces and, using adhesive in color to match countertop, form seams to comply with quartz agglomerate manufacturer's written instructions. Carefully dress joints smooth, remove surface scratches, and clean entire surface.
 - 6. Bond joints with adhesive and draw tight as countertops are set. Mask areas of countertops adjacent to joints to prevent adhesive smears.
 - a. Install metal splines in kerfs in countertop edges at joints. Fill kerfs with adhesive before inserting splines and remove excess immediately after adjoining units are drawn into position.
 - b. Clamp units to temporary bracing, supports, or each other to ensure that countertops are properly aligned and joints are of specified width.
 - 7. Install backsplashes and end splashes by adhering to wall and countertops with adhesive. Mask areas of countertops and splashes adjacent to joints to prevent adhesive smears.
 - 8. Install aprons to backing and countertops with adhesive. Mask areas of countertops and splashes adjacent to joints to prevent adhesive smears. Fasten by screwing through backing. Predrill holes for screws as recommended by manufacturer.
 - 9. Seal joints between countertop and backsplash, if any, and joints where countertop and backsplash abut walls. Comply with Section 079200 "Joint Sealants."

3.4 ADJUSTING AND CLEANING

- A. Repair damaged and defective countertops, where possible, to eliminate functional and visual defects. Where not possible to repair, replace countertops. Adjust joinery for uniform appearance.
- B. Clean countertops on exposed and semi-exposed surfaces.
- C. Protection: Provide Kraft paper or other suitable covering over countertop surfaces, taped to underside of countertop at a minimum of **48 inches** o.c. Remove protection at Substantial Completion.

END OF SECTION 123661

SECTION 21 05 00 - COMMON WORK RESULTS FOR FIRE SUPPRESSION

PART 1 GENERAL

1.1 SECTION INCLUDES

- A. Escutcheons.
- B. Fire rated enclosures.
- C. Mechanical couplings.
- D. Pipe hangers and supports.

1.2 RELATED REQUIREMENTS

- A. Section 21 13 00 - Fire-Suppression Sprinkler Systems: Sprinkler systems design.

1.3 REFERENCE STANDARDS

- A. ASTM A536 - Standard Specification for Ductile Iron Castings; 2024.
- B. NFPA 13 - Standard for the Installation of Sprinkler Systems; Most Recent Edition Adopted by Authority Having Jurisdiction, Including All Applicable Amendments and Supplements.

1.4 SUBMITTALS

- A. See Section 01 30 00 - Administrative Requirements for submittal procedures.
- B. Product Data: Provide manufacturer's catalog information. Indicate valve data and ratings.
- C. Shop Drawings: Indicate pipe materials used, jointing methods, supports, and floor and wall penetration seals. Indicate installation, layout, mounting and support details, and piping connections.

1.5 QUALITY ASSURANCE

- A. Manufacturer Qualifications: Company specializing in manufacturing the Products specified in this section with minimum three years documented experience.
- B. Installer Qualifications: Company specializing in performing work of the type specified in this section.
 - 1. Approved by manufacturer.
- C. Products Requiring Electrical Connection: Listed and classified as suitable for the purpose specified and indicated.
- D. Clean equipment, pipes, valves, and fittings of grease, metal cuttings, and sludge that may have accumulated from the installation and testing of the system.

PART 2 PRODUCTS

2.1 GENERAL REQUIREMENTS

- A. Sprinkler-based System:
 - 1. Comply with NFPA 13.
 - 2. See Section 21 13 00.
- B. Welding Materials and Procedures: Comply with ASME BPVC-IX.
- C. Provide system pipes, fittings, escutcheons, seals, and other related accessories.

2.2 FIRE-RATED ENCLOSURES

- A. Provide as required to preserve fire resistance rating of building elements.

2.3 ESCUTCHEONS

- A. Material:
 - 1. Metals and Finish: Comply with ASME A112.18.1.
- B. Construction:
 - 1. One-piece for mounting on chrome-plated tubing or pipe and one-piece or split-pattern type elsewhere.
 - 2. Internal spring tension devices or setscrews to maintain a fixed position against a surface.

2.4 PIPE HANGERS AND SUPPORTS

- A. Hangers for Pipe Sizes 1/2 to 1-1/2 inch: Malleable iron, adjustable swivel, split ring.
- B. Wall Support for Pipe Sizes 4 inches and Over: Welded steel bracket and wrought steel clamp.
- C. Vertical Support: Steel riser clamp.
- D. Floor Support: Cast iron adjustable pipe saddle, lock nut, nipple, floor flange, and concrete pier or steel support.

2.5 MECHANICAL COUPLINGS

- A. Rigid Mechanical Couplings for Grooved Joints:
 - 1. Dimensions and Testing: Comply with AWWA C606.
 - 2. Minimum Working Pressure: 175 psig.
 - 3. Housing Material: Fabricate of ductile iron complying with ASTM A536.
 - 4. Housing Coating: Factory applied orange enamel.
 - 5. Gasket Material: EPDM suitable for operating temperature range from minus 30 degrees F to 230 degrees F.
 - 6. Bolts and Nuts: Hot-dipped-galvanized or zinc-electroplated steel.

PART 3 EXECUTION

3.1 PREPARATION

3.2 INSTALLATION

- A. Install sprinkler system and service main piping, hangers, and supports in accordance with NFPA 13.
- B. Route piping in orderly manner, plumb and parallel to building structure. Maintain gradient.
- C. Install piping to conserve building space, to not interfere with use of space and other work.
- D. Group piping whenever practical at common elevations.
- E. Install piping to allow for expansion and contraction without stressing pipe, joints, or connected equipment.
- F. Pipe Hangers and Supports:
 - 1. Install hangers to provide minimum 1/2 inch space between finished covering and adjacent work.
 - 2. Use hangers with 1-1/2 inch minimum vertical adjustment. Design hangers for pipe movement without disengagement of supported pipe.
 - 3. Support vertical piping at every other floor. Support riser piping independently of connected horizontal piping.
 - 4. Where several pipes can be installed in parallel and at same elevation, provide multiple or trapeze hangers.
- G. Prepare pipe, fittings, supports, and accessories for finish painting. Where pipe support members are welded to structural building framing, scrape, brush clean, and apply one coat of zinc-rich primer to welding.
- H. Escutcheons:
 - 1. Install and firmly attach escutcheons at piping penetrations into finished spaces.
 - 2. Provide escutcheons on both sides of partitions separating finished areas through which piping passes.
 - 3. Use chrome plated escutcheons in occupied spaces and to conceal openings in construction.
- I. When installing more than one piping system material, ensure system components are compatible and joined to ensure the integrity of the system. Provide necessary joining fittings. Ensure flanges, unions, and couplings for servicing are consistently provided.

END OF SECTION

This page intentionally left blank

SECTION 21 05 53 - IDENTIFICATION FOR FIRE SUPPRESSION PIPING AND EQUIPMENT

PART 1 GENERAL

1.1 SECTION INCLUDES

- A. Tags.
- B. Pipe markers.

1.2 REFERENCE STANDARDS

- A. ASME A13.1 - Scheme for the Identification of Piping Systems; 2023.

PART 2 PRODUCTS

2.1 IDENTIFICATION APPLICATIONS

- A. Piping: Pipe markers.

2.2 TAGS

2.3 PIPE MARKERS

- A. Color: Comply with ASME A13.1.
- B. Plastic Pipe Markers: Factory fabricated, flexible, semi-rigid plastic, preformed to fit around pipe or pipe covering; minimum information indicating flow direction arrow and identification of fluid being conveyed.

PART 3 EXECUTION

3.1 PREPARATION

- A. Degrease and clean surfaces to receive adhesive for identification materials.

3.2 INSTALLATION

- A. Install plastic pipe markers in accordance with manufacturer's instructions.
- B. Install plastic tape pipe markers complete around pipe in accordance with manufacturer's instructions.

END OF SECTION

This page intentionally left blank

SECTION 21 13 00 - FIRE-SUPPRESSION SPRINKLER SYSTEMS

PART 1 GENERAL

1.1 SECTION INCLUDES

- A. System design, installation, and certification.

1.2 RELATED REQUIREMENTS

1.3 REFERENCE STANDARDS

- A. NFPA 13 - Standard for the Installation of Sprinkler Systems; Most Recent Edition Adopted by Authority Having Jurisdiction, Including All Applicable Amendments and Supplements.
- B. UL (DIR) - Online Certifications Directory; Current Edition.

1.4 SUBMITTALS

- A. See Section 01 30 00 - Administrative Requirements for submittal procedures.
- B. Shop Drawings:
 - 1. Submit preliminary layout of finished ceiling areas indicating only sprinkler locations coordinated with ceiling installation.
 - 2. Indicate hydraulic calculations, detailed pipe layout, hangers and supports, sprinklers, components, and accessories. Indicate system controls.
- C. Operation and Maintenance Data: Include components of system, servicing requirements, record drawings, inspection data, replacement part numbers and availability, and location and numbers of service depot.
- D. Maintenance Materials: Furnish the following for Owner's use in maintenance of project.
 - 1. See Section 01 60 00 - Product Requirements for additional provisions.
 - 2. Extra Sprinklers: Type and size matching those installed in quantity required by referenced NFPA design and installation standard.
 - 3. Sprinkler Wrenches: For each sprinkler type.
- E. Project Record Documents: Record actual locations of sprinklers and deviations of piping from drawings. Indicate drain and test locations.

1.5 QUALITY ASSURANCE

- A. Maintain one copy of referenced design and installation standard on site.
- B. Designer Qualifications: Design system under direct supervision of a Professional Engineer experienced in design of this type of work and licensed in the State in which the Project is located.
- C. Products Requiring Electrical Connection: Listed and classified by UL (DIR) as suitable for the purpose specified and indicated.

PART 2 PRODUCTS

2.1 SPRINKLER SYSTEM

- A. Sprinkler System: Provide coverage for entire building.
- B. Occupancy: Light hazard; comply with NFPA 13.
- C. Water Supply: Determine volume and pressure from water flow test data.
- D. Storage Cabinet for Spare Sprinklers and Tools: Steel, located adjacent to alarm valve.

2.2 SPRINKLERS

- A. Suspended Ceiling Type: Recessed pendant type with matching push on escutcheon plate.
 - 1. Response Type: Quick.
 - 2. Coverage Type: Standard.
 - 3. Fusible Link: Fusible solder link type temperature rated for specific area hazard.
- B. Exposed Area Type: Pendant type with guard.
 - 1. Response Type: Quick.
 - 2. Coverage Type: Standard.
 - 3. Fusible Link: Fusible solder link type temperature rated for specific area hazard.
- C. Sidewall Type: Recessed horizontal sidewall type with matching push on escutcheon plate.
 - 1. Response Type: Quick.
 - 2. Coverage Type: Standard.
 - 3. Fusible Link: Fusible solder link type temperature rated for specific area hazard.
- D. Guards: Finish to match sprinkler finish.
- E. Spray Nozzles: Brass with solid cone discharge, 30 degrees of arc with blow-off dust cap.
 - 1. Finish: Brass.

PART 3 EXECUTION

3.1 INSTALLATION

- A. Install in accordance with referenced NFPA design and installation standard.
- B. Install equipment in accordance with manufacturer's instructions.
- C. Place pipe runs to minimize obstruction to other work.
- D. Place piping in concealed spaces above finished ceilings.
- E. Center sprinklers in two directions in ceiling tile and provide piping offsets as required.
- F. Apply masking tape or paper cover to ensure concealed sprinklers, cover plates, and sprinkler escutcheons do not receive field paint finish. Remove after painting. Replace painted sprinklers.

- G. Flush entire piping system of foreign matter.
- H. Install guards on sprinklers where indicated.
- I. Hydrostatically test entire system.
- J. Require test be witnessed by Fire Marshal.

3.2 INTERFACE WITH OTHER PRODUCTS

- A. Ensure required devices are installed and connected as required to fire alarm system.

END OF SECTION

SECTION 21 13 00 - FIRE-SUPPRESSION SPRINKLER SYSTEMS

PART 1 GENERAL

1.1 SECTION INCLUDES

- A. System design, installation, and certification.

1.2 RELATED REQUIREMENTS

1.3 REFERENCE STANDARDS

- A. NFPA 13 - Standard for the Installation of Sprinkler Systems; Most Recent Edition Adopted by Authority Having Jurisdiction, Including All Applicable Amendments and Supplements.
- B. UL (DIR) - Online Certifications Directory; Current Edition.

1.4 SUBMITTALS

- A. See Section 01 30 00 - Administrative Requirements for submittal procedures.
- B. Shop Drawings:
 - 1. Submit preliminary layout of finished ceiling areas indicating only sprinkler locations coordinated with ceiling installation.
 - 2. Indicate hydraulic calculations, detailed pipe layout, hangers and supports, sprinklers, components, and accessories. Indicate system controls.
- C. Operation and Maintenance Data: Include components of system, servicing requirements, record drawings, inspection data, replacement part numbers and availability, and location and numbers of service depot.
- D. Project Record Documents: Record actual locations of sprinklers and deviations of piping from drawings. Indicate drain and test locations.

1.5 QUALITY ASSURANCE

- A. Maintain one copy of referenced design and installation standard on site.
- B. Designer Qualifications: Design system under direct supervision of a Professional Engineer experienced in design of this type of work and licensed in the State in which the Project is located.
- C. Products Requiring Electrical Connection: Listed and classified by UL (DIR) as suitable for the purpose specified and indicated.

PART 2 PRODUCTS

2.1 SPRINKLER SYSTEM

- A. Sprinkler System: Provide coverage for entire building.

- B. Occupancy: Light hazard; comply with NFPA 13.
- C. Water Supply: Determine volume and pressure from water flow test data.

2.2 SPRINKLERS

- A. Suspended Ceiling Type: Recessed pendant type with matching push on escutcheon plate.
 - 1. Response Type: Quick.
 - 2. Coverage Type: Extended.
 - 3. Fusible Link: Glass bulb type temperature rated for specific area hazard.
- B. Exposed Area Type: Pendant type with guard.
 - 1. Response Type: Quick.
 - 2. Coverage Type: Extended.
 - 3. Fusible Link: Glass bulb type temperature rated for specific area hazard.
- C. Sidewall Type: Recessed horizontal sidewall type with matching push on escutcheon plate.
 - 1. Response Type: Quick.
 - 2. Coverage Type: Extended.
 - 3. Fusible Link: Glass bulb type temperature rated for specific area hazard.
- D. Guards: Finish to match sprinkler finish.

PART 3 EXECUTION

3.1 INSTALLATION

- A. Install in accordance with referenced NFPA design and installation standard.
- B. Install equipment in accordance with manufacturer's instructions.
- C. Place pipe runs to minimize obstruction to other work.
- D. Place piping in concealed spaces above finished ceilings.
- E. Center sprinklers in two directions in ceiling tile and provide piping offsets as required.
- F. Install guards on sprinklers where indicated.
- G. Hydrostatically test entire system.
- H. Require test be witnessed by Fire Marshal.

3.2 INTERFACE WITH OTHER PRODUCTS

- A. Ensure required devices are installed and connected as required to fire alarm system.

END OF SECTION

SECTION 22 05 16 - EXPANSION FITTINGS AND LOOPS FOR PLUMBING PIPING

PART 1 GENERAL

1.1 SECTION INCLUDES

- A. Flexible pipe connectors.
- B. Expansion joints and compensators.

1.2 RELATED REQUIREMENTS

- A. Section 21 05 00 - Common Work Results for Fire Suppression.
- B. Section 22 10 05 - Plumbing Piping.

1.3 REFERENCE STANDARDS

- A. EJMA (STDS) - EJMA Standards; Tenth Edition.

1.4 SUBMITTALS

- A. See Section 01 30 00 - Administrative Requirements for submittal procedures.
- B. Product Data:
 - 1. Flexible Pipe Connectors: Indicate maximum temperature and pressure rating, face-to-face length, live length, hose wall thickness, hose convolutions per foot and per assembly, fundamental frequency of assembly, braid structure, and total number of wires in braid.
 - 2. Expansion Joints: Indicate maximum temperature and pressure rating, and maximum expansion compensation.

PART 2 PRODUCTS

2.1 FLEXIBLE PIPE CONNECTORS - COPPER PIPING

- A. Inner Hose: Bronze.
- B. Exterior Sleeve: Braided bronze.
- C. End Connections: Flanged.
- D. Size: Use pipe sized units.
- E. Maximum offset: 3/4 inch on each side of installed center line.
- F. Application: Copper piping.

2.2 EXPANSION JOINTS - COMPENSATORS

- A. Type: Two-ply 304 stainless steel bellows with carbon steel shroud.
- B. Maximum Working Pressure: 200 psi.

- C. Maximum Working Temperature: 400 degrees F.
- D. Maximum Compression: 1/2 inch.
- E. Maximum Extension: 5/32 inch.
- F. End Connections: Female copper sweat.
- G. Application: Copper piping up to 3 inches in size or steel piping up to 4 inches in size.

2.3 EXPANSION JOINTS - COPPER WITH PACKED SLIDING SLEEVE

- A. Working Pressure: 125 psi.
- B. Maximum Temperature: 250 degrees F.
- C. End Connections: Flanged.
- D. Size: Use pipe sized units.
- E. Application: Copper or steel piping 2 inches and over.

2.4 EXPANSION JOINTS - HOSE AND BRAID

- A. Provide flexible loops with two flexible sections of hose and braid, two 90 degree elbows, and 180 degree return with support brackets and plugged drain port for steam service.
- B. Maximum Allowable Motion: 2 inch in the x, y, and z planes with no thrust loads to the building structure.
- C. Maximum Working Pressure: 150 psi at 800 degrees F.
- D. Construction: Class 150, schedule 40, stainless steel hose and braid assembly with carbon steel fittings, including elbows and flanged end connections sized to match pipe segment.
 - 1. Selected Product to Accommodate:
 - a. Angular Rotation: 15 degrees.
 - b. Force developed by 1.5 times specified maximum allowable operating pressure.
 - 2. Provide necessary accessories including, but not limited to, swivel joints.

PART 3 EXECUTION

3.1 INSTALLATION

- A. Install in accordance with manufacturer's instructions.
- B. Install in accordance with EJMA (Expansion Joint Manufacturers Association) Standards.
- C. Install flexible connectors at right angles to displacement. Install one end immediately adjacent to isolated equipment and anchor other end. Install in horizontal plane unless indicated otherwise.
- D. Provide support and equipment required to control expansion and contraction of piping. Provide loops, pipe offsets, and swing joints, or expansion joints where required.

END OF SECTION

SECTION 22 05 17 - SLEEVES AND SLEEVE SEALS FOR PLUMBING PIPING

PART 1 GENERAL

1.1 SECTION INCLUDES

- A. Pipe sleeves.
- B. Pipe sleeve-seals.

1.2 RELATED REQUIREMENTS

- A. Section 22 05 23 - General-Duty Valves for Plumbing Piping.
- B. Section 22 05 53 - Identification for Plumbing Piping and Equipment: Piping identification.
- C. Section 22 07 19 - Plumbing Piping Insulation.

1.3 REFERENCE STANDARDS

PART 2 PRODUCTS

2.1 PIPE SLEEVES

- A. Vertical Piping:
 - 1. Sleeve Length: 1 inch above finished floor.
 - 2. Provide sealant for watertight joint.
- B. Pipe Passing Through Concrete Beam Flanges, except where Brass Pipe Sleeves are Specified:
 - 1. Galvanized steel pipe or black iron pipe with asphalt coating.
 - 2. Connect sleeve with floor plate except in mechanical rooms.

2.2 PIPE-SLEEVE SEALS

- A. Modular Mechanical Sleeve-Seal:
 - 1. Elastomer-based interlocking links continuously fill annular space between pipe and wall-sleeve, wall or casing opening.
 - 2. Watertight seal between pipe and wall-sleeve, wall or casing opening.
 - 3. Size and select seal component materials in accordance with service requirements.
 - 4. Glass-reinforced plastic pressure end plates.

PART 3 EXECUTION

3.1 INSTALLATION

- A. Route piping in orderly manner, plumb and parallel to building structure. Maintain gradient.
- B. Install piping to conserve building space, to not interfere with use of space and other work.

- C. Install piping and pipe sleeves to allow for expansion and contraction without stressing pipe, joints, or connected equipment.
- D. Provide sleeves when penetrating footings, floors, walls, and partitions. Seal pipe including sleeve penetrations to achieve fire resistance equivalent to fire separation required.
- E. Manufactured Sleeve-Seal Systems:
 - 1. Install manufactured sleeve-seal systems in sleeves located in grade slabs and exterior concrete walls at piping entrances into building.
 - 2. Provide sealing elements of the size, quantity, and type required for the piping and sleeve inner diameter or penetration diameter.
 - 3. Locate piping in center of sleeve or penetration.
 - 4. Install field assembled sleeve-seal system components in annular space between sleeve and piping.
 - 5. Tighten bolting for a water-tight seal.
 - 6. Install in accordance with manufacturer's recommendations.
- F. When installing more than one piping system material, ensure system components are compatible and joined to ensure the integrity of the system. Provide necessary joining fittings. Ensure flanges, union, and couplings for servicing are consistently provided.

END OF SECTION

SECTION 22 05 23 - GENERAL-DUTY VALVES FOR PLUMBING PIPING

PART 1 GENERAL

1.1 SECTION INCLUDES

- A. Angle valves.
- B. Ball valves.

1.2 RELATED REQUIREMENTS

1.3 ABBREVIATIONS AND ACRONYMS

- A. CWP: Cold working pressure.
- B. EPDM: Ethylene propylene copolymer rubber.
- C. NBR: Acrylonitrile-butadiene, Buna-N, or nitrile rubber.
- D. NRS: Non-rising stem.
- E. OS&Y: Outside screw and yoke.
- F. PTFE: Polytetrafluoroethylene.
- G. RS: Rising stem.
- H. TFE: Tetrafluoroethylene.
- I. WOG: Water, oil, and gas.

1.4 REFERENCE STANDARDS

- A. ASME B1.20.1 - Pipe Threads, General Purpose, Inch; 2013 (Reaffirmed 2018).
- B. ASME B16.18 - Cast Copper Alloy Solder Joint Pressure Fittings; 2021.
- C. ASTM B62 - Standard Specification for Composition Bronze or Ounce Metal Castings; 2017.
- D. MSS SP-80 - Bronze Gate, Globe, Angle, and Check Valves; 2019.
- E. MSS SP-110 - Ball Valves Threaded, Socket-Welding, Solder Joint, Grooved and Flared Ends; 2010, with Errata .
- F. NSF 61 - Drinking Water System Components - Health Effects; 2024.
- G. NSF 372 - Drinking Water System Components - Lead Content; 2022.

1.5 SUBMITTALS

- A. See Section 01 30 00 - Administrative Requirements for submittal procedures.

1.6 QUALITY ASSURANCE

- A. Manufacturer:
 - 1. Obtain valves for each valve type from single manufacturer.

1.7 DELIVERY, STORAGE, AND HANDLING

- A. Prepare valves for shipping as follows:
 - 1. Minimize exposure of operable surfaces by setting plug and ball valves to open position.
 - 2. Protect valve piping connections such as grooves, weld ends, threads, and flange faces.
 - 3. Adjust globe, gate, and angle valves to the closed position to avoid clattering.
 - 4. Secure check valves in either the closed position or open position.
 - 5. Adjust butterfly valves to closed or partially closed position.
- B. Use the following precautions during storage:
 - 1. Maintain valve end protection and protect flanges and specialties from dirt.
 - a. Provide temporary inlet and outlet caps.
 - b. Maintain caps in place until installation.
 - 2. Store valves in shipping containers and maintain in place until installation.
 - a. Store valves indoors in dry environment.

PART 2 PRODUCTS

2.1 APPLICATIONS

- A. Listed pipe sizes shown using nominal pipe sizes (NPS) and nominal diameter (DN).
- B. Provide the following valves for the applications if not indicated on drawings:
 - 1. Shutoff: Ball, butterfly, gate or plug.
 - 2. Throttling: Provide globe, angle, ball, or butterfly.
- C. Substitutions of valves with higher CWP classes or WSP ratings for same valve types are permitted when specified CWP ratings or WSP classes are not available.
- D. Required Valve End Connections for Non-Wafer Types:
 - 1. Copper Tube:
 - a. 2 inch and Smaller: Threaded ends except where solder-joint valve-end option is indicated in valve schedules below.
 - b. 2-1/2 inch to 4 inch: Grooved or flanged ends except where threaded valve-end option is indicated in valve schedules below.
- E. Domestic, Hot and Cold Water Valves:
 - 1. 2 inch and Smaller:
 - a. Bronze and Brass: Provide with solder-joint ends.
 - b. Bronze Angle: Class 125, bronze disc.
 - c. Ball: One piece, full port, brass with brass trim.

2.2 GENERAL REQUIREMENTS

- A. Valve Pressure and Temperature Ratings: No less than rating indicated; as required for system pressures and temperatures.
- B. Valve Sizes: Match upstream piping unless otherwise indicated.
- C. Valve Actuator Types:
 - 1. Hand Lever: Quarter-turn valves 6 inch and smaller except plug valves.
- D. Insulated Piping Valves: With 2 inch stem extensions and the following features:
 - 1. Gate Valves: Rising stem.
 - 2. Ball Valves: Extended operating handle of non-thermal-conductive material, and protective sleeve that allows operation of valve without breaking the vapor seal or disturbing insulation.
- E. Valve-End Connections:
 - 1. Threaded End Valves: ASME B1.20.1.
 - 2. Solder Joint Connections: ASME B16.18.
- F. General ASME Compliance:
 - 1. Solder-joint Connections: ASME B16.18.
- G. Potable Water Use:
 - 1. Certified: Approved for use in compliance with NSF 61 and NSF 372.
 - 2. Lead-Free Certified: Wetted surface material includes less than 0.25 percent lead content.

2.3 BRONZE, ANGLE VALVES

- A. Class 125; CWP Rating: 200 psi:
 - 1. Comply with MSS SP-80, Type 1.
 - 2. Body: Bronze; ASTM B62, with integral seat and screw in bonnet.
 - 3. End Connections: Pipe thread.
 - 4. Stem: Bronze.
 - 5. Disc: Bronze.
 - 6. Packing: Asbestos free.
 - 7. Handwheel: Bronze or aluminum.

2.4 BRASS, BALL VALVES

- A. Two Piece, Full Port with Brass Trim and Female Thread, Male thread, or Solder Connections:
 - 1. Comply with MSS SP-110.
 - 2. WSP Rating: 150 psi.
 - 3. WOG Rating: 600 psi.

4. Body: Forged brass.
5. Seats: PTFE.
6. Ball: Chrome-plated brass.
7. Operator: Lockable handle and memory stop.

2.5 BRONZE, BALL VALVES

A. General:

1. Fabricate from dezincification resistant material.
2. Copper alloys containing more than 15 percent zinc are not permitted.

B. One Piece, Reduced Port with Bronze Trim:

1. Comply with MSS SP-110.
2. WSP Rating: 400 psi.
3. CWP Rating: 600 psi.
4. Body: Bronze.
5. End Connections: Pipe press.
6. Seats: PTFE.

PART 3 EXECUTION

3.1 INSTALLATION

- A. Provide unions or flanges with valves to facilitate equipment removal and maintenance while maintaining system operation and full accessibility for servicing.
- B. Provide separate valve support as required and locate valve with stem at or above center of piping, maintaining unimpeded stem movement.

END OF SECTION

SECTION 22 05 29 - HANGERS AND SUPPORTS FOR PLUMBING PIPING AND EQUIPMENT

PART 1 GENERAL

1.1 SECTION INCLUDES

- A. Support and attachment components for equipment, piping, and other plumbing work.

1.2 RELATED REQUIREMENTS

- A. Section 03 30 00 - Cast-in-Place Concrete: Concrete equipment pads.
- B. Section 05 50 00 - Metal Fabrications: Materials and requirements for fabricated metal supports.

1.3 REFERENCE STANDARDS

- A. ASTM A123/A123M - Standard Specification for Zinc (Hot-Dip Galvanized) Coatings on Iron and Steel Products; 2024.
- B. ASTM A153/A153M - Standard Specification for Zinc Coating (Hot-Dip) on Iron and Steel Hardware; 2023.
- C. ASTM A181/A181M - Standard Specification for Carbon Steel Forgings, for General-Purpose Piping; 2023.
- D. ASTM A36/A36M - Standard Specification for Carbon Structural Steel; 2019.
- E. ASTM A47/A47M - Standard Specification for Ferritic Malleable Iron Castings; 1999, with Editorial Revision (2022).
- F. ASTM B633 - Standard Specification for Electrodeposited Coatings of Zinc on Iron and Steel; 2023.
- G. ASTM E84 - Standard Test Method for Surface Burning Characteristics of Building Materials; 2023d.
- H. ASTM E96/E96M - Standard Test Methods for Gravimetric Determination of Water Vapor Transmission Rate of Materials; 2023.
- I. MFMA-4 - Metal Framing Standards Publication; 2004.
- J. MSS SP-58 - Pipe Hangers and Supports - Materials, Design, Manufacture, Selection, Application, and Installation; 2018, with Amendment (2019).
- K. UL 723 - Standard for Test for Surface Burning Characteristics of Building Materials; Current Edition, Including All Revisions.

1.4 ADMINISTRATIVE REQUIREMENTS

- A. Coordination:
 - 1. Coordinate sizes and arrangement of supports and bases with the actual equipment and components to be installed.

2. Coordinate the work with other trades to provide additional framing and materials required for installation.
3. Coordinate compatibility of support and attachment components with mounting surfaces at the installed locations.
4. Coordinate the arrangement of supports with ductwork, piping, equipment and other potential conflicts installed under other sections or by others.
5. Notify Architect of any conflicts with or deviations from Contract Documents. Obtain direction before proceeding with work.

B. Sequencing:

1. Do not install products on or provide attachment to concrete surfaces until concrete has fully cured in accordance with Section 03 30 00.

1.5 SUBMITTALS

- A. See Section 01 30 00 - Administrative Requirements, for submittal procedures.
- B. Product Data: Provide manufacturer's standard catalog pages and data sheets for metal channel (strut) framing systems, nonpenetrating rooftop supports, post-installed concrete and masonry anchors, and thermal insulated pipe supports.

1.6 QUALITY ASSURANCE

- A. Comply with applicable building code.
- B. Installer Qualifications for Field-Welding: As specified in Section 05 50 00.

1.7 DELIVERY, STORAGE, AND HANDLING

- A. Receive, inspect, handle, and store products in accordance with manufacturer's instructions.

PART 2 PRODUCTS

2.1 SUPPORT AND ATTACHMENT COMPONENTS

A. General Requirements:

1. Provide all required hangers, supports, anchors, fasteners, fittings, accessories, and hardware as necessary for the complete installation of plumbing work.
2. Provide products listed, classified, and labeled as suitable for the purpose intended, where applicable.
3. Where support and attachment component types and sizes are not indicated, select in accordance with manufacturer's application criteria as required for the load to be supported with a minimum safety factor of 10%. Include consideration for vibration, equipment operation, and shock loads where applicable.
4. Do not use wire, chain, perforated pipe strap, or wood for permanent supports unless specifically indicated or permitted.

5. Steel Components: Use corrosion resistant materials suitable for the environment where installed.
 - a. Indoor Dry Locations: Use zinc-plated steel or approved equivalent unless otherwise indicated.
 - b. Outdoor and Damp or Wet Indoor Locations: Use galvanized steel, stainless steel, or approved equivalent unless otherwise indicated.
 - c. Zinc-Plated Steel: Electroplated in accordance with ASTM B633.
 - d. Galvanized Steel: Hot-dip galvanized after fabrication in accordance with ASTM A123/A123M or ASTM A153/A153M.
- B. Metal Channel (Strut) Framing Systems:
 1. Comply with MFMA-4.
 2. Channel Material:
 - a. Indoor Dry Locations: Use painted steel, zinc-plated steel, or galvanized steel.
 - b. Outdoor and Damp or Wet Indoor Locations: Use galvanized steel.
 3. Minimum Channel Thickness: Steel sheet, 12 gage, 0.1046 inch.
 4. Minimum Channel Dimensions: 1-5/8 inch width by 13/16 inch height.
- C. Hanger Rods: Threaded zinc-plated steel unless otherwise indicated.
 1. Minimum Size, Unless Otherwise Indicated or Required:
 - a. Piping up to 1 inch (27 mm) nominal: 1/4 inch diameter.
 - b. Piping larger than 1 inch (27 mm) nominal: 3/8 inch diameter.
 - c. Trapeze Support for Multiple Pipes: 3/8 inch diameter.
- D. Thermal Insulated Pipe Supports:
 1. General Construction and Requirements:
 - a. Insulated pipe supports to be provided at hanger, support, and guide locations on pipe requiring insulation or additional support.
 - b. Surface Burning Characteristics: Flame spread index/smoke developed index of 5/30, maximum, when tested in accordance with ASTM E84 or UL 723.
 - c. Pipe supports to be provided for nominally sized, 1/2 inch to 30 inch iron pipes.
 - d. Insulation inserts to consist of rigid phenolic foam insulation surrounded by a 360 degree, PVC jacketing.
 2. PVC Jacket:
 - a. Pipe insulation protection shields to be provided with a ball bearing hinge and locking seam.
 - b. Maximum Service Temperature: 180 degrees F.
 - c. Moisture Vapor Transmission: 0.0071 perm inch, when tested in accordance with ASTM E96/E96M.

- d. Thickness: 60 mil.
3. Pipe insulation protection shields to be provided at the hanger points and guide locations on pipes requiring insulation as indicated on drawings.
- E. Pipe Supports:
 1. Liquid Temperatures Up To 122 degrees F:
 - a. Overhead Support: MSS SP-58 Types 1, 3 through 12.
 - b. Support From Below: MSS SP-58 Types 35 through 38.
- F. Pipe Stanchions: For pipe runs, use stanchions of same type and material where vertical adjustment is required for stationary pipe.
 1. Material: Malleable iron, ASTM A47/A47M; or carbon steel, ASTM A36/A36M.
 2. Provide coated or plated saddles to isolate steel hangers from dissimilar metal tube or pipe.
- G. Beam Clamps: MSS SP-58 Types 19 through 23, 25 or 27 through 30 based on required load.
 1. Material: ASTM A36/A36M carbon steel or ASTM A181/A181M forged steel.
 2. Provide clamps with hardened steel cup-point set screws and lock-nuts for anchoring in place.
- H. Insulation Clamps: Two bolt-type clamps designed for installation under insulation.
- I. Pipe Hangers: For a given pipe run, use hangers of the same type and material.
 1. Material: Malleable iron, ASTM A47/A47M; or carbon steel, ASTM A36/A36M.
 2. Provide coated or plated hangers to isolate steel hangers from dissimilar metal tube or pipe.
- J. Pipe Alignment Guides: Galvanized steel.
 1. Pipe Diameter 8 inches and Smaller: Spider or sleeve type.
 2. Pipe Diameter 10 inches and Larger: Roller type.
- K. Nonpenetrating Rooftop Supports for Low-Slope Roofs:
 1. Provide steel pedestals with thermoplastic or rubber base that rest on top of roofing membrane, not requiring any attachment to the roof structure and not penetrating the roofing assembly, with support fixtures as specified.
 2. Base Sizes: As required to distribute load sufficiently to prevent indentation of roofing assembly.
 3. Attachment/Support Fixtures: As recommended by manufacturer, same type as indicated for equivalent indoor hangers and supports.
 4. Mounting Height: Provide minimum clearance of 6 inches under supported component to top of roofing.
- L. Pipe Shields for Insulated Piping:
 1. General Construction and Requirements:

- a. Surface Burning Characteristics: Comply with ASTM E84 or UL 723.
 - b. Shields Material: UV-resistant polypropylene with glass fill.
 - c. Maximum Insulated Pipe Outer Diameter: 12-5/8 inch.
 - d. Minimum Service Temperature: Minus 40 degrees F.
 - e. Maximum Service Temperature: 178 degrees F.
 - f. Pipe shields to be provided at hanger, support, and guide locations on pipe requiring insulation or additional support.
- M. Anchors and Fasteners:
1. Unless otherwise indicated and where not otherwise restricted, use the anchor and fastener types indicated for the specified applications.
 2. Concrete: Use preset concrete inserts, expansion anchors, or screw anchors.
 3. Solid or Grout-Filled Masonry: Use expansion anchors or screw anchors.
 4. Hollow Stud Walls: Use toggle bolts.
 5. Steel: Use beam clamps, machine bolts, or welded threaded studs.
 6. Wood: Use wood screws.
 7. Plastic and lead anchors are not permitted.
 8. Powder-actuated fasteners are not permitted.
 9. Preset Concrete Inserts: Continuous metal channel (strut) and spot inserts specifically designed to be cast in concrete ceilings, walls, and floors.
 - a. Comply with MFMA-4.
 - b. Channel Material: Use galvanized steel.
 - c. Manufacturer: Same as manufacturer of metal channel (strut) framing system.

PART 3 EXECUTION

3.1 EXAMINATION

- A. Verify that field measurements are as indicated.
- B. Verify that mounting surfaces are ready to receive support and attachment components.
- C. Verify that conditions are satisfactory for installation prior to starting work.

3.2 INSTALLATION

- A. Install products in accordance with manufacturer's instructions.
- B. Provide independent support from building structure. Do not provide support from piping, ductwork, conduit, or other systems.
- C. Unless specifically indicated or approved by Architect, do not provide support from suspended ceiling support system or ceiling grid.

- D. Unless specifically indicated or approved by Architect, do not provide support from roof deck.
- E. Do not penetrate or otherwise notch or cut structural members without approval of Structural Engineer.
- F. Provide thermal insulated pipe supports complete with hangers and accessories. Install thermal insulated pipe supports during the installation of the piping system.
- G. Equipment Support and Attachment:
 - 1. Use metal fabricated supports or supports assembled from metal channel (strut) to support equipment as required.
 - 2. Use metal channel (strut) secured to studs to support equipment surface-mounted on hollow stud walls when wall strength is not sufficient to resist pull-out.
 - 3. Use metal channel (strut) to support surface-mounted equipment in wet or damp locations to provide space between equipment and mounting surface.
 - 4. Securely fasten floor-mounted equipment. Do not install equipment such that it relies on its own weight for support.
- H. Preset Concrete Inserts: Use manufacturer-provided closure strips to inhibit concrete seepage during concrete pour.
- I. Secure fasteners according to manufacturer's recommended torque settings.
- J. Remove temporary supports.

3.3 FIELD QUALITY CONTROL

- A. See Section 01 40 00 - Quality Requirements, for additional requirements.
- B. Inspect support and attachment components for damage and defects.
- C. Repair cuts and abrasions in galvanized finishes using zinc-rich paint recommended by manufacturer. Replace components that exhibit signs of corrosion.
- D. Correct deficiencies and replace damaged or defective support and attachment components.

END OF SECTION

SECTION 22 05 53 - IDENTIFICATION FOR PLUMBING PIPING AND EQUIPMENT

PART 1 GENERAL

1.1 SECTION INCLUDES

- A. Pipe markers.
- B. Ceiling tacks.

1.2 RELATED REQUIREMENTS

- A. Section 09 91 23 - Interior Painting: Identification painting.

1.3 REFERENCE STANDARDS

- A. ASME A13.1 - Scheme for the Identification of Piping Systems; 2023.

1.4 SUBMITTALS

- A. See Section 01 30 00 - Administrative Requirements, for submittal procedures.
- B. Product Data: Provide manufacturers catalog literature for each product required.

PART 2 PRODUCTS

2.1 IDENTIFICATION APPLICATIONS

- A. Piping: Pipe markers.
- B. Valves: Tags and ceiling tacks where located above lay-in ceiling.

2.2 PIPE MARKERS

- A. Comply with ASME A13.1.
- B. Plastic Pipe Markers: Factory fabricated, flexible, semi-rigid plastic, preformed to fit around pipe or pipe covering; minimum information indicating flow direction arrow and identification of fluid being conveyed.
- C. Plastic Tape Pipe Markers: Flexible, vinyl film tape with pressure sensitive adhesive backing and printed markings.
- D. Underground Plastic Pipe Markers: Bright colored continuously printed plastic ribbon tape, minimum 6 inches wide by 4 mil thick, manufactured for direct burial service.

2.3 CEILING TACKS

- A. Description: Steel with 3/4 inch diameter color coded head.
- B. Color code as follows:
 - 1. HVAC Equipment: Yellow.
 - 2. Fire Dampers and Smoke Dampers: Red.

3. Plumbing Valves: Green.
4. Heating/Cooling Valves: Blue.

PART 3 EXECUTION

3.1 PREPARATION

- A. Degrease and clean surfaces to receive adhesive for identification materials.
- B. Prepare surfaces in accordance with Section 09 91 23 for stencil painting.

3.2 INSTALLATION

- A. Install plastic nameplates with corrosive-resistant mechanical fasteners, or adhesive. Apply with sufficient adhesive to ensure permanent adhesion and seal with clear lacquer.
- B. Install tags with corrosion resistant chain.
- C. Apply stencil painting in accordance with Section 09 91 23.
- D. Install plastic pipe markers in accordance with manufacturer's instructions.
- E. Install plastic tape pipe markers complete around pipe in accordance with manufacturer's instructions.
- F. Locate ceiling tacks to locate valves or dampers above lay-in panel ceilings. Locate in corner of panel closest to equipment.

END OF SECTION

SECTION 22 07 19 - PLUMBING PIPING INSULATION

PART 1 GENERAL

1.1 SECTION INCLUDES

- A. Piping insulation.
- B. Jackets and accessories.

1.2 RELATED REQUIREMENTS

- A. Section 07 84 00 - Firestopping.
- B. Section 22 10 05 - Plumbing Piping: Placement of hangers and hanger inserts.
- C. Section 23 21 13 - Hydronic Piping: Placement of hangers and hanger inserts.

1.3 REFERENCE STANDARDS

- A. ASTM C195 - Standard Specification for Mineral Fiber Thermal Insulating Cement; 2007 (Reapproved 2024).
- B. ASTM C534/C534M - Standard Specification for Preformed Flexible Elastomeric Cellular Thermal Insulation in Sheet and Tubular Form; 2025.
- C. ASTM C547 - Standard Specification for Mineral Fiber Pipe Insulation; 2022a.
- D. ASTM C552 - Standard Specification for Cellular Glass Thermal Insulation; 2022.
- E. ASTM C795 - Standard Specification for Thermal Insulation for Use in Contact with Austenitic Stainless Steel; 2008 (Reapproved 2023).
- F. ASTM E84 - Standard Test Method for Surface Burning Characteristics of Building Materials; 2023d.
- G. ASTM E96/E96M - Standard Test Methods for Gravimetric Determination of Water Vapor Transmission Rate of Materials; 2023.
- H. UL 723 - Standard for Test for Surface Burning Characteristics of Building Materials; Current Edition, Including All Revisions.

1.4 SUBMITTALS

- A. See Section 01 30 00 - Administrative Requirements, for submittal procedures.
- B. Product Data: Provide product description, thermal characteristics, list of materials and thickness for each service, and locations.

1.5 DELIVERY, STORAGE, AND HANDLING

- A. Accept materials on site, labeled with manufacturer's identification, product density, and thickness.

1.6 FIELD CONDITIONS

- A. Maintain ambient conditions required by manufacturers of each product.
- B. Maintain temperature before, during, and after installation for minimum of 24 hours.

PART 2 PRODUCTS

2.1 REGULATORY REQUIREMENTS

- A. Surface Burning Characteristics: Flame spread index/Smoke developed index of 25/50, maximum, when tested in accordance with ASTM E84 or UL 723.

2.2 GLASS FIBER

- A. Insulation: ASTM C547 and ASTM C795; rigid molded, noncombustible.
 - 1. K Value: ASTM C177, 0.24 at 75 degrees F.
 - 2. Maximum Service Temperature: 850 degrees F.
 - 3. Maximum Moisture Absorption: 0.2 percent by volume.
- B. Vapor Barrier Jacket: White Kraft paper with glass fiber yarn, bonded to aluminized film; moisture vapor transmission when tested in accordance with ASTM E96/E96M of 0.02 perm-inches.
- C. Vapor Barrier Lap Adhesive: Compatible with insulation.
- D. Insulating Cement/Mastic: ASTM C195; hydraulic setting on mineral wool.

2.3 CELLULAR GLASS

- A. Insulation: ASTM C552, Type II, Grade 6.
 - 1. K Value: 0.35 at 100 degrees F.
 - 2. Service Temperature Range: From 250 degrees F to 800 degrees F.
 - 3. Water Vapor Permeability: 0.005 perm inch maximum per inch.
 - 4. Water Absorption: 0.5 percent by volume, maximum.

2.4 FLEXIBLE ELASTOMERIC CELLULAR INSULATION

- A. Insulation: Preformed flexible elastomeric cellular rubber insulation complying with ASTM C534/C534M Grade 1; use molded tubular material wherever possible.
 - 1. Minimum Service Temperature: Minus 40 degrees F.
 - 2. Maximum Service Temperature: 220 degrees F.
 - 3. Connection: Waterproof vapor barrier adhesive.

2.5 JACKETS

- A. PVC Plastic.
 - 1. Jacket: One piece molded type fitting covers and sheet material, off-white color.

- a. Minimum Service Temperature: 0 degrees F.
 - b. Maximum Service Temperature: 150 degrees F.
 - c. Moisture Vapor Permeability: 0.002 perm inch, maximum, when tested in accordance with ASTM E96/E96M.
 - d. Thickness: 10 mil.
 - e. Connections: Brush on welding adhesive.
2. Covering Adhesive Mastic: Compatible with insulation.

PART 3 EXECUTION

3.1 EXAMINATION

- A. Verify that piping has been tested before applying insulation materials.
- B. Verify that surfaces are clean and dry, with foreign material removed.

3.2 INSTALLATION

- A. Install in accordance with manufacturer's instructions.
- B. Exposed Piping: Locate insulation and cover seams in least visible locations.
- C. Insulated pipes conveying fluids below ambient temperature: Insulate entire system including fittings, valves, unions, flanges, strainers, flexible connections, pump bodies, and expansion joints.
- D. Install cellular melamine with factory-applied jackets with a manufacturer-approved adhesive along seams, both straight lap joints and circumferential lap joints.
- E. Glass fiber insulated pipes conveying fluids below ambient temperature:
 1. Provide vapor barrier jackets, factory-applied or field-applied. Secure with self-sealing longitudinal laps and butt strips with pressure sensitive adhesive. Secure with outward clinch expanding staples and vapor barrier mastic.
 2. Insulate fittings, joints, and valves with molded insulation of like material and thickness as adjacent pipe. Finish with glass cloth and vapor barrier adhesive or PVC fitting covers.
- F. For hot piping conveying fluids 140 degrees F or less, do not insulate flanges and unions at equipment, but bevel and seal ends of insulation.
- G. Glass fiber insulated pipes conveying fluids above ambient temperature:
 1. Provide standard jackets, with or without vapor barrier, factory-applied or field-applied. Secure with self-sealing longitudinal laps and butt strips with pressure sensitive adhesive. Secure with outward clinch expanding staples.
 2. Insulate fittings, joints, and valves with insulation of like material and thickness as adjoining pipe. Finish with glass cloth and adhesive or PVC fitting covers.
- H. Inserts and Shields:
 1. Application: Piping 1-1/2 inches diameter or larger.

2. Shields: Galvanized steel between pipe hangers or pipe hanger rolls and inserts.
 3. Insert Location: Between support shield and piping and under the finish jacket.
 4. Insert Configuration: Minimum 6 inches long, of same thickness and contour as adjoining insulation; may be factory fabricated.
 5. Insert Material: Hydrous calcium silicate insulation or other heavy density insulating material suitable for the planned temperature range.
- I. Continue insulation through walls, sleeves, pipe hangers, and other pipe penetrations. Finish at supports, protrusions, and interruptions. At fire separations, refer to Section 07 84 00.
 - J. Pipe Exposed in Mechanical Equipment Rooms or Finished Spaces (less than 10 feet above finished floor): Finish with canvas jacket sized for finish painting.

END OF SECTION

SECTION 22 07 19.11 - UNDER-LAVATORY PIPE AND SUPPLY COVERS

PART 1 GENERAL

1.1 SECTION INCLUDES

- A. Under-lavatory pipe and supply covers.

1.2 RELATED REQUIREMENTS

- A. Section 22 10 05 - Plumbing Piping.

1.3 REFERENCE STANDARDS

- A. ADA Standards - 2010 ADA Standards for Accessible Design; 2010.
- B. ASME A112.18.9 - Protectors/Insulators for Exposed Waste and Supplies on Accessible Fixtures; 2011 (Reaffirmed 2022).
- C. ASTM C177 - Standard Test Method for Steady-State Heat Flux Measurements and Thermal Transmission Properties by Means of the Guarded-Hot-Plate Apparatus; 2019, with Editorial Revision (2023).
- D. ASTM C518 - Standard Test Method for Steady-State Thermal Transmission Properties by Means of the Heat Flow Meter Apparatus; 2021.
- E. ASTM C1822 - Standard Specification for Insulating Covers on Accessible Lavatory Piping; 2021.
- F. ASTM G21 - Standard Practice for Determining Resistance of Synthetic Polymeric Materials to Fungi; 2015, with Editorial Revision (2021).

1.4 SUBMITTALS

- A. See Section 01 30 00 - Administrative Requirements, for submittal procedures.
- B. Product Data: Provide catalog illustrations of covers, sizes, and finishes.

1.5 QUALITY ASSURANCE

- A. Manufacturer Qualifications: Company specializing in manufacturing the type of products specified in this section, with minimum three years of documented experience.

PART 2 PRODUCTS

2.1 UNDER-LAVATORY PIPE AND SUPPLY COVERS

- A. General:
 - 1. Insulate exposed drainage piping including hot, cold, and tempered water supplies under lavatories or sinks per ADA Standards.
 - 2. Adhesives, sewing threads, and two-ply laminated materials are prohibited.

3. Exterior Surfaces: Smooth nonabsorbent with no finger recessed indentations for easy cleaning.
 4. Construction: 1/8 inch PVC with antimicrobial, antifungal, and ultraviolet light (UV) resistant properties.
 - a. Provide one piece injected molded design with internal bridge at top of J-bend to prevent separating.
 - b. Comply with ASTM C1822 for covers on accessible lavatory piping.
 - c. Comply with ASME A112.18.9 for covers on accessible lavatory piping.
 - d. Thermal Resistance: R value of 0.504 or lower when tested by ASTM C177.
 - e. Thermal Conductivity: K value of 0.358 or density of 21.61 pcf per ASTM C518.
 - f. Microbial and Fungal Resistance for Interior and Exterior: Comply with ASTM G21.
- B. Under-Lavatory Covers with Snap-Lock Fasteners:
1. Construction: PVC with antimicrobial, antifungal, and UV-resistant properties, one piece injected molded design with internal bridge at top of J-bend to prevent separating.
 2. Fasteners: Reusable, snap-locking fasteners with no sharp or abrasive external surfaces. No cable ties allowed.
 3. Maintenance: Valve and supply cover shall be accessible for maintenance without removal and with removable, reusable access cap.
 4. Color: High gloss white.

PART 3 EXECUTION

3.1 EXAMINATION

- A. Verify that walls, floor finishes, lavatories, and piping are prepared and ready for installation of under-lavatory guards.
- B. Confirm location and size of fixtures and piping before installation.

3.2 INSTALLATION

- A. Install under-lavatory guards according to manufacturer's written instructions..

3.3 CLEANING

- A. Clean installed under-lavatory guards.

3.4 PROTECTION

- A. Protect installed products from damage due to subsequent construction operations.
- B. Repair or replace damaged products before Date of Substantial Completion.

END OF SECTION

SECTION 22 10 05 - PLUMBING PIPING

PART 1 GENERAL

1.1 SECTION INCLUDES

1.2 RELATED REQUIREMENTS

- A. Section 07 84 00 - Firestopping.
- B. Section 08 31 00 - Access Doors and Panels.
- C. Section 22 05 16 - Expansion Fittings and Loops for Plumbing Piping.
- D. Section 22 05 53 - Identification for Plumbing Piping and Equipment.
- E. Section 22 07 19 - Plumbing Piping Insulation.

1.3 SUBMITTALS

- A. See Section 01 30 00 - Administrative Requirements, for submittal procedures.
- B. Product Data: Provide data on pipe materials, pipe fittings, valves, and accessories. Provide manufacturers catalog information. Indicate valve data and ratings.

1.4 QUALITY ASSURANCE

- A. Perform work in accordance with applicable codes.
- B. Valves: Manufacturer's name and pressure rating marked on valve body.
- C. Welding Materials and Procedures: Comply with ASME BPVC-IX and applicable state labor regulations.
- D. Welder Qualifications: Certified in accordance with ASME BPVC-IX.

1.5 DELIVERY, STORAGE, AND HANDLING

- A. Accept valves on site in shipping containers with labeling in place. Inspect for damage.
- B. Provide temporary end caps and closures on piping and fittings. Maintain in place until installation.

1.6 FIELD CONDITIONS

- A. Do not install underground piping when bedding is wet or frozen.

PART 2 PRODUCTS

2.1 GENERAL REQUIREMENTS

- A. Potable Water Supply Systems: Provide piping, pipe fittings, and solder and flux (if used), that comply with NSF 61 and NSF 372 for maximum lead content; label pipe and fittings.

2.2 SANITARY SEWER PIPING, BURIED WITHIN 5 FEET OF BUILDING

- A. Cast Iron Pipe: CISPI 301, hubless.
 - 1. Fittings: Cast iron.
 - 2. Joints: CISPI 310, neoprene gasket and stainless steel clamp and shield assemblies.
- B. PVC Pipe: ASTM D2665 or ASTM D3034.
 - 1. Fittings: PVC.
 - 2. Joints: Solvent welded, with ASTM D2564 solvent cement.

2.3 SANITARY SEWER PIPING, ABOVE GRADE

- A. Cast Iron Pipe: CISPI 301, hubless, service weight.
 - 1. Fittings: Cast iron.
 - 2. Joints: CISPI 310, neoprene gaskets and stainless steel clamp-and-shield assemblies.
- B. CPVC Pipe: ASTM D2846/D2846M, ASTM F441/F441M, or ASTM F442/F442M.
 - 1. Fittings: CPVC; ASTM D2846/D2846M, ASTM F437, ASTM F438, or ASTM F439.
 - 2. Joints: ASTM D2846/D2846M, solvent weld with ASTM F493 solvent cement.
- C. PVC Pipe: ASTM D2729.
 - 1. Fittings: PVC.
 - 2. Joints: Solvent welded, with ASTM D2564 solvent cement.

2.4 DOMESTIC WATER PIPING, ABOVE GRADE

- A. Copper Tube: ASTM B88 (ASTM B88M), Type L (B), Drawn (H).
 - 1. Fittings: ASME B16.18, cast copper alloy or ASME B16.22, wrought copper and bronze.
 - 2. Joints: ASTM B32, alloy Sn95 solder.
 - 3. Mechanical Press Sealed Fittings: Double-pressed type, NSF 61 and NSF 372 approved or certified, utilizing EPDM, nontoxic, synthetic rubber sealing elements.

2.5 STORM WATER PIPING, BURIED WITHIN 5 FEET OF BUILDING

- A. Cast Iron Pipe: CISPI 301, hubless, service weight.
 - 1. Fittings: Cast iron.
 - 2. Joints: Neoprene gaskets and stainless steel clamp-and-shield assemblies.
- B. PVC Pipe: ASTM D2665 or ASTM D3034.
 - 1. Fittings: PVC.
 - 2. Joints: Solvent welded, with ASTM D2564 solvent cement.

2.6 STORM WATER PIPING, ABOVE GRADE

- A. Cast Iron Pipe: CISPI 301, hubless, service weight.

1. Fittings: Cast iron.
2. Joints: Neoprene gaskets and stainless steel clamp-and-shield assemblies.

2.7 NATURAL GAS PIPING, BURIED WITHIN 5 FEET OF BUILDING

- A. Steel Pipe: ASTM A53/A53M Schedule 40 black.
 1. Fittings: ASTM A234/A234M, wrought steel welding type.
 2. Joints: ASME B31.1, welded.
 3. Jacket: AWWA C105/A21.5 polyethylene jacket or double layer, half-lapped 10 mil polyethylene tape.

2.8 NATURAL GAS PIPING, ABOVE GRADE

- A. Steel Pipe: ASTM A53/A53M Schedule 40 black.
 1. Fittings: ASME B16.3, malleable iron, or ASTM A234/A234M, wrought steel welding type.
 2. Joints: Threaded or welded to ASME B31.1.

2.9 FLANGES, UNIONS, AND COUPLINGS

- A. Unions for Pipe Sizes 3 Inches and Under:
 1. Ferrous Pipe: Class 150 malleable iron threaded unions.
 2. Copper Tube and Pipe: Class 150 bronze unions with soldered joints.
- B. Flanges for Pipe Size Over 1 Inch:
 1. Ferrous Pipe: Class 150 malleable iron threaded or forged steel slip-on flanges; preformed neoprene gaskets.
 2. Copper Tube and Pipe: Class 150 slip-on bronze flanges; preformed neoprene gaskets.
- C. No-Hub Couplings:
 1. Gasket Material: Neoprene complying with ASTM C564.
 2. Band Material: Stainless steel.
 3. Eyelet Material: Stainless steel.

PART 3 EXECUTION

3.1 EXAMINATION

- A. Verify that excavations are to required grade, dry, and not over-excavated.

3.2 PREPARATION

- A. Ream pipe and tube ends. Remove burrs. Bevel plain end ferrous pipe.
- B. Remove scale and dirt, on inside and outside, before assembly.
- C. Prepare piping connections to equipment with flanges or unions.

3.3 INSTALLATION

- A. Install in accordance with manufacturer's instructions.
- B. Provide non-conducting dielectric connections wherever jointing dissimilar metals.
- C. Route piping in orderly manner and maintain gradient. Route parallel and perpendicular to walls.
- D. Install piping to maintain headroom, conserve space, and not interfere with use of space.
- E. Group piping whenever practical at common elevations.
- F. Install piping to allow for expansion and contraction without stressing pipe, joints, or connected equipment. Refer to Section 22 05 16.
- G. Provide clearance in hangers and from structure and other equipment for installation of insulation and access to valves and fittings.
 - 1. Refer to Section 22 07 19.
- H. Provide access where valves and fittings are not exposed.
- I. Prepare exposed, unfinished pipe, fittings, supports, and accessories for finish painting.
 - 1. See Section 09 91 23 for painting of interior plumbing systems and components.
- J. Install valves with stems upright or horizontal, not inverted. Refer to Section 22 05 23.
- K. Install water piping to ASME B31.9.
- L. Copper Pipe and Tube: Make soldered joints in accordance with ASTM B828, using specified solder, and flux meeting ASTM B813; in potable water systems use flux also complying with NSF 61 and NSF 372.
- M. PVC Pipe: Make solvent-welded joints in accordance with ASTM D2855.

3.4 APPLICATION

- A. Install unions downstream of valves and at equipment or apparatus connections.
- B. Install brass male adapters each side of valves in copper piped system. Solder adapters to pipe.
- C. Install gate valves for shut-off and to isolate equipment, part of systems, or vertical risers.
- D. Install globe valves for throttling, bypass, or manual flow control services.
- E. Provide spring-loaded check valves on discharge of water pumps.

END OF SECTION

SECTION 22 10 06 - PLUMBING PIPING SPECIALTIES

PART 1 GENERAL

1.1 SECTION INCLUDES

- A. Cleanouts.
- B. Water hammer arrestors.
- C. Mixing valves.
- D. Exterior penetration accessories.

1.2 RELATED REQUIREMENTS

- A. Section 22 10 05 - Plumbing Piping.
- B. Section 22 40 00 - Plumbing Fixtures.

1.3 SUBMITTALS

- A. See Section 01 30 00 - Administrative Requirements, for submittal procedures.
- B. Product Data: Provide component sizes, rough-in requirements, service sizes, and finishes.

1.4 DELIVERY, STORAGE, AND HANDLING

- A. Accept specialties on site in original factory packaging. Inspect for damage.

PART 2 PRODUCTS

2.1 GENERAL REQUIREMENTS

- A. Specialties in Potable Water Supply Systems: Provide products that comply with NSF 61 and NSF 372 for maximum lead content.

2.2 CLEANOUTS

- A. Cleanouts at Interior Finished Floor Areas:
 - 1. Lacquered cast iron body with anchor flange, reversible clamping collar, threaded top assembly, and round gasketed scored cover in service areas and round gasketed depressed cover to accept floor finish in finished floor areas.
- B. Cleanouts at Interior Finished Wall Areas:
 - 1. Line type with lacquered cast iron body and round epoxy coated gasketed cover, and round stainless steel access cover secured with machine screw.
- C. Cleanouts at Interior Unfinished Accessible Areas: Calked or threaded type. Provide bolted stack cleanouts on vertical rainwater leaders.

2.3 WATER HAMMER ARRESTORS

A. Water Hammer Arrestors:

1. Stainless steel construction, bellows type sized in accordance with PDI-WH 201, precharged suitable for operation in temperature range minus 100 to 300 degrees F and maximum 250 psi working pressure.

2.4 MIXING VALVES

A. Thermostatic Mixing Valves:

1. Valve: Chrome plated cast brass body, stainless steel or copper alloy bellows, integral temperature adjustment.
2. Accessories:
 - a. Check valve on inlets.
 - b. Volume control shut-off valve on outlet.
 - c. Stem thermometer on outlet.
 - d. Strainer stop checks on inlets.
3. Cabinet: 16 gage, 0.0598 inch prime coated steel, for recessed mounting with keyed lock.

2.5 RELIEF VALVES

- A. Bronze body, teflon seat, stainless steel stem and springs, automatic, direct pressure actuated, capacities ASME certified and labelled.

2.6 AIR VENTS

A. Float Type:

1. Brass or semi-steel body, copper, polypropylene, or solid non-metallic float, stainless steel valve and valve seat; suitable for system operating temperature and pressure; with isolating valve.

2.7 FLOOR DRAIN TRAP SEALS

- A. Description: Push-fit EPDM or silicone fitting with a one-way membrane.

2.8 EXTERIOR PENETRATION ACCESSORIES

- A. Flashing Panels for Exterior Wall Penetrations: Premanufactured components and accessories as required to preserve integrity of building envelope; suitable for conduits and facade materials to be installed.
- B. Roof Drain Outlet Pipe Connection: Drain seal to connect roof drain to drain piping.
- C. Sealing Systems for Roof Penetrations: Premanufactured components and accessories as required to preserve integrity of roofing system and maintain roof warranty; suitable for piping, cables, and roofing system to be installed; designed to accommodate existing penetrations where applicable.

PART 3 EXECUTION

3.1 INSTALLATION

- A. Install in accordance with manufacturer's instructions.
- B. Extend cleanouts to finished floor or wall surface. Lubricate threaded cleanout plugs with mixture of graphite and linseed oil. Ensure clearance at cleanout for rodding of drainage system.
- C. Install floor cleanouts at elevation to accommodate finished floor.
- D. Install approved potable water protection devices on plumbing lines where contamination of domestic water may occur; on boiler feed water lines, janitor rooms, fire sprinkler systems, premise isolation, irrigation systems, flush valves, interior and exterior hose bibbs.
- E. Install water hammer arrestors complete with accessible isolation valve on hot and cold water supply piping to lavatory sinks.

END OF SECTION

This page intentionally left blank

SECTION 22 11 19 - DOMESTIC WATER PIPING SPECIALTIES

PART 1 GENERAL

1.1 SECTION INCLUDES

- A. Mixing valves.
- B. Water-hammer arrestors.

1.2 RELATED REQUIREMENTS

- A. Section 22 10 05 - Plumbing Piping: Pipe, fittings, and joints.

1.3 SUBMITTALS

- A. See Section 01 30 00 - Administrative Requirements for submittal procedures.
- B. Product Data: Provide manufacturer's literature and data sheets for each product. Include information on materials of fabrication, assembly of components, dimensions, ratings, finishes, rough-in requirements, and installed accessories.

1.4 DELIVERY, STORAGE, AND HANDLING

- A. Receive, inspect, handle, and store products in accordance with manufacturer's instructions.
- B. Keep products in original manufacturer's packaging and protect from damage until ready for installation.
- C. Store products under cover and protected from weather and dirt. Elevate above grade.
- D. Protect end connections, flanges, threads, and grooves from dirt and damage.
- E. Protect product interiors against rust and corrosion.
- F. Do not use operating handles or stems as lifting or rigging points.

PART 2 PRODUCTS

2.1 GENERAL REQUIREMENTS

- A. Specialties in Potable Water Supply Systems: Provide products complying with NSF 61 and NSF 372.
- B. Source Limitations: Furnish domestic water piping specialties of same kind by same manufacturer.
- C. Provide brass-bodied domestic water piping specialties in DZR brass.

2.2 MIXING VALVES

- A. Thermostatic Master Mixing Valves:
 - 1. Valve: ASSE 1017, brass or bronze body; thermostatic element; corrosion- and lime-resistant internal components; integral locking temperature adjustment.

2.3 WATER-HAMMER ARRESTORS

A. Piston Type:

1. Description: ASSE 1010 or PDI-WH 201, copper body with plastic piston and EPDM O-rings.
2. Air Preload Pressure: 60 psi.
3. Maximum Working Pressure: 150 psi.
4. Working Temperature Range: 33 to 180 degrees F.

B. Bellows Type:

1. Description: ASSE 1010 or PDI-WH 201, stainless steel body with stainless steel bellows.
2. Maximum Working Pressure: 150 psi.
3. Working Temperature Range: 33 to 180 degrees F.

PART 3 EXECUTION

3.1 INSTALLATION

- A. Prior to installation of domestic water piping specialties, flush domestic water piping of foreign material.
- B. Install products in accordance with manufacturer's instructions.
- C. Install products level and plumb.
- D. Install products with clearance for access and maintenance.
- E. Support products NPS 2-1/2 and larger independently of surrounding pipe.
- F. Support products with flanged or grooved ends independently of surrounding pipe.
- G. For products containing isolation or shutoff valves, locate valves in horizontal piping with stems at or above center of piping, maintaining unimpeded stem movement.
- H. Water Hammer Arrestors: Install in accordance with PDI-WH 201.

3.2 FIELD QUALITY CONTROL

- A. See Section 01 40 00 - Quality Requirements for additional requirements.
- B. Inspect each product for damage and defects.
- C. Repair or replace damaged products.
- D. Replace defective products.
- E. For products containing isolation or shutoff valves, exercise isolation and shutoff valves from fully closed to fully open. Confirm smooth operation.
- F. Mixing Valves: Confirm outlet temperature remains steady without fluctuation.
- G. Coordination of Other Tests and Inspections: Provide access to accommodate tests and inspections by independent testing agencies employed by Owner.

Intersect Studio, LLC
23046

Kalamazoo Crosstown
Parkway Facility
Kalamazoo, Michigan

3.3 ADJUSTING

- A. Adjust mixing valves to design temperature set point.

END OF SECTION

This page intentionally left blank

SECTION 22 40 00 - PLUMBING FIXTURES

PART 1 GENERAL

1.1 SECTION INCLUDES

- A. Lavatories.
- B. Sinks.
- C. Electric water coolers.

1.2 RELATED REQUIREMENTS

- A. Section 12 36 00 - Countertops: Preparation of counters for sinks and lavatories.
- B. Section 22 10 05 - Plumbing Piping.
- C. Section 22 10 06 - Plumbing Piping Specialties.

1.3 REFERENCE STANDARDS

- A. ASHRAE Std 18 - Methods of Testing for Rating Drinking-Water Coolers with Self-Contained Mechanical Refrigeration; 2008 (Reaffirmed 2013).
- B. ASME A112.19.2 - Ceramic Plumbing Fixtures; 2024.
- C. ASME A112.19.3 - Stainless Steel Plumbing Fixtures; 2022.
- D. NSF 61 - Drinking Water System Components - Health Effects; 2024.
- E. NSF 372 - Drinking Water System Components - Lead Content; 2022.

1.4 SUBMITTALS

- A. See Section 01 30 00 - Administrative Requirements, for submittal procedures.
- B. Product Data: Provide catalog illustrations of fixtures, sizes, rough-in dimensions, utility sizes, trim, and finishes.
- C. Warranty: Submit manufacturer warranty and ensure forms have been completed in Owner's name and registered with manufacturer.

1.5 QUALITY ASSURANCE

- A. Manufacturer Qualifications: Company specializing in manufacturing the type of products specified in this section, with minimum three years of documented experience.

1.6 DELIVERY, STORAGE, AND HANDLING

- A. Accept fixtures on site in factory packaging. Inspect for damage.
- B. Protect installed fixtures from damage by securing areas and by leaving factory packaging in place to protect fixtures and prevent use.

1.7 WARRANTY

- A. See Section 01 78 00 - Closeout Submittals, for additional warranty requirements.
- B. Provide five year manufacturer warranty for electric water cooler.

PART 2 PRODUCTS

2.1 GENERAL REQUIREMENTS

- A. Potable Water Systems: Provide plumbing fittings and faucets that comply with NSF 61 and NSF 372 for maximum lead content; label pipe and fittings.

2.2 REGULATORY REQUIREMENTS

- A. Comply with applicable codes for installation of plumbing systems.
- B. Perform work in accordance with local health department regulations.

2.3 LAVATORIES

- A. Vitreous China: Refer to Plans.
- B. Sensor Operated Faucet: Refer to Plans.
 - 1. Water Supply: 3/8 inch compression connections.
 - 2. Aerator: Vandal resistant, 0.5 GPM, laminar flow device.
- C. Provide lavatory with combination stop and strainer.
- D. Accessories:
 - 1. Chrome plated 17 gage, 0.0538 inch brass P-trap with clean-out plug and arm with escutcheon.

2.4 SINKS

- A. Double Compartment Bowl: ASME A112.19.3; outside dimensions 20 gage, 0.0359 inch thick, Type 302 stainless steel, self rimming and undercoated, with ledge back drilled for trim.
 - 1. Drain: 1-1/2 inch chromed brass drain.

2.5 ELECTRIC WATER COOLERS

- A. Water Cooler: Refer to Plans.
 - 1. Capacity: 8 gallons per hour of 50 degrees F water with inlet at 80 degrees F and room temperature of 90 degrees F, when tested in accordance with ASHRAE Std 18.
 - 2. Electrical: 115 V, 60 Hertz compressor, 6 foot cord and plug for connection to electric wiring system including grounding connector.
- B. Bottle Filler: Materials to match fountain.

2.6 BI-LEVEL, ELECTRIC WATER COOLERS

- A. Water Cooler: Bi-level, electric, mechanically refrigerated; surface mounted, ADA compliant; stainless steel top, vinyl on steel body, elevated anti-squirt bubbler with stream guard, automatic stream regulator, push button, mounting bracket; integral air cooled condenser and stainless steel grille.
 - 1. Capacity: 8 gallons per hour of 50 degrees F water with inlet at 80 degrees F and room temperature of 90 degrees F, when tested in accordance with ASHRAE Std 18.
 - 2. Electrical: 115 V, 60 Hertz compressor, 6 foot cord and plug for connection to electric wiring system including grounding connector.
- B. Bottle Filler: Materials to match fountain.

PART 3 EXECUTION

3.1 EXAMINATION

- A. Verify that walls and floor finishes are prepared and ready for installation of fixtures.
- B. Verify that electric power is available and of the correct characteristics.
- C. Confirm that millwork is constructed with adequate provision for the installation of counter top lavatories and sinks.

3.2 PREPARATION

- A. Rough-in fixture piping connections in accordance with minimum sizes indicated in fixture rough-in schedule for particular fixtures.

3.3 INSTALLATION

- A. Install each fixture with trap, easily removable for servicing and cleaning.
- B. Provide chrome plated rigid or flexible supplies to fixtures with loose key stops, reducers, and escutcheons.
- C. Install components level and plumb.
- D. Install and secure fixtures in place with wall supports and bolts.
- E. Solidly attach water closets to floor with lag screws. Lead flashing is not intended hold fixture in place.

3.4 INTERFACE WITH WORK OF OTHER SECTIONS

- A. Review millwork shop drawings. Confirm location and size of fixtures and openings before rough-in and installation.

3.5 ADJUSTING

- A. Adjust stops or valves for intended water flow rate to fixtures without splashing, noise, or overflow.

3.6 CLEANING

- A. Clean plumbing fixtures and equipment.

3.7 PROTECTION

- A. Protect installed products from damage due to subsequent construction operations.
- B. Do not permit use of fixtures by construction personnel.
- C. Repair or replace damaged products before Date of Substantial Completion.

END OF SECTION

SECTION 23 05 16 - EXPANSION FITTINGS AND LOOPS FOR HVAC PIPING

PART 1 GENERAL

1.1 SECTION INCLUDES

- A. Flexible pipe connectors.
- B. Expansion joints and compensators.

1.2 RELATED REQUIREMENTS

- A. Section 23 21 13 - Hydronic Piping.
- B. Section 23 23 00 - Refrigerant Piping.

1.3 REFERENCE STANDARDS

- A. ASTM A269/A269M - Standard Specification for Seamless and Welded Austenitic Stainless Steel Tubing for General Service; 2024.
- B. EJMA (STDS) - EJMA Standards; Tenth Edition.
- C. UL (DIR) - Online Certifications Directory; Current Edition.

1.4 SUBMITTALS

- A. See Section 01 30 00 - Administrative Requirements for submittal procedures.
- B. Product Data:
 - 1. Flexible Pipe Connectors: Indicate maximum temperature and pressure rating, face-to-face length, live length, hose wall thickness, hose convolutions per foot and per assembly, fundamental frequency of assembly, braid structure, and total number of wires in braid.
 - 2. Expansion Joints: Indicate maximum temperature and pressure rating, and maximum expansion compensation.

PART 2 PRODUCTS

2.1 REGULATORY REQUIREMENTS

- A. Comply with UL (DIR) requirements.

2.2 FLEXIBLE PIPE CONNECTORS - STEEL PIPING

- A. Inner Hose: Bronze.
- B. Exterior Sleeve: Single braided, stainless steel.
- C. Pressure Rating: 125 psi up to 12 inch.
- D. Maximum Service Temperature: 450 degrees F.

- E. End Connections: Flanged.
- F. Size: Use pipe sized units.
- G. Maximum offset: 3/4 inch on each side of installed center line.

2.3 FLEXIBLE PIPE CONNECTORS - COPPER PIPING

- A. Inner Hose: Bronze.
- B. Exterior Sleeve: Braided bronze.
- C. Pressure Rating: 125 psi up to 2 inch.
- D. Maximum Service Temperature: 450 degrees F.
- E. End Connections: Flanged.
- F. Size: Use pipe sized units.
- G. Maximum offset: 3/4 inch on each side of installed center line.
- H. Application: Copper piping.

2.4 EXPANSION JOINTS - STAINLESS STEEL BELLOWS TYPE

- A. Pressure Rating: 125 psi and 400 degrees F.
- B. Maximum Compression: 1-3/4 inches.
- C. Maximum Extension: 1/4 inch.
- D. End Connections: Externally pressurized with flanged ends.
- E. Size: Use pipe sized units.
- F. Application: Steel piping 3 inches and under.

2.5 EXPANSION JOINTS - TWO-PLY BRONZE BELLOWS TYPE

- A. Construction: Bronze with anti-torque device, limit stops, internal guides.
- B. Pressure Rating: 125 psi and 400 degrees F.
- C. Maximum Compression: 1-3/4 inches.
- D. Maximum Extension: 1/4 inch.
- E. End Connections: Soldered.
- F. Size: Use pipe sized units.
- G. Application: Copper piping.

2.6 EXPANSION JOINTS - COMPENSATORS

- A. Type: Two-ply 304 stainless steel bellows with carbon steel shroud.
- B. Maximum Working Pressure: 200 psi.
- C. Maximum Working Temperatures: 400 degrees F.
- D. End Connections: Female copper sweat.

- E. Application: Copper piping up to 3 inches in size or steel piping up to 4 inches in size.

2.7 EXPANSION JOINTS - COPPER WITH PACKED SLIDING SLEEVE

- A. Working Pressure: 125 psi.
- B. Maximum Temperature: 250 degrees F.
- C. End Connections: Flanged.
- D. Size: Use pipe sized units.
- E. Application: Copper or steel piping 2 inches and over.

2.8 EXPANSION JOINTS - HOSE AND BRAID

- A. Provide flexible loops with two flexible sections of hose and braid, two 90 degree elbows, and 180 degree return with support brackets and plugged drain port for steam service.
- B. Maximum Allowable Motion: 2 inch in the x, y, and z planes with no thrust loads to the building structure
- C. Maximum Working Pressure: 150 psi at 800 degrees F.
- D. Construction: Class 150, schedule 40, stainless steel hose and braid assembly with carbon steel fittings, including elbows and flanged end connections sized to match pipe segment
 - 1. Selected Product to Accommodate:
 - a. Angular Rotation: 15 degrees.
 - b. Force developed by 1.5 times specified maximum allowable operating pressure.
 - 2. Provide necessary accessories including, but not limited to, swivel joints.

PART 3 EXECUTION

3.1 INSTALLATION

- A. Install in accordance with manufacturer's instructions.
- B. Install in accordance with EJMA (Expansion Joint Manufacturers Association) Standards.
- C. Install flexible pipe connectors on pipes connected to vibration isolated equipment. Provide line size flexible connectors.
- D. Install flexible connectors at right angles to displacement. Install one end immediately adjacent to isolated equipment and anchor other end. Install in horizontal plane unless indicated otherwise.
- E. Anchor pipe to building structure where indicated. Provide pipe guides so movement is directed along axis of pipe only. Erect piping such that strain and weight is not on cast connections or apparatus.

EXPANSION FITTINGS AND LOOPS FOR HVAC PIPINGIntersect
Studio, LLC
23046

Kalamazoo Crosstown
Parkway Facility
Kalamazoo, Michigan

- F. Provide support and equipment required to control expansion and contraction of piping.
Provide loops, pipe offsets, and swing joints, or expansion joints where required.

END OF SECTION

SECTION 23 05 17 - SLEEVES AND SLEEVE SEALS FOR HVAC PIPING

PART 1 GENERAL

1.1 SECTION INCLUDES

- A. Pipe sleeves.
- B. Pipe-sleeve seals.

1.2 RELATED REQUIREMENTS

1.3 REFERENCE STANDARDS

- A. ASTM E814 - Standard Test Method for Fire Tests of Penetration Firestop Systems; 2024.

1.4 DELIVERY, STORAGE, AND HANDLING

- A. Deliver and store sleeve and sleeve seals in shipping containers, with labeling in place.
- B. Provide temporary protective coating on cast iron and steel sleeves if shipped loose.

PART 2 PRODUCTS

2.1 PIPE SLEEVES

- A. Vertical Piping:
 - 1. Sleeve Length: 1 inch above finished floor.
 - 2. Provide sealant for watertight joint.
- B. Plastic or Sheet Metal: Pipe passing through interior walls, partitions, and floors, unless steel or brass sleeves are specified below.
- C. Clearances:
 - 1. Provide allowance for insulated piping.
 - 2. Wall, Floor, Partitions, and Beam Flanges: 1 inch greater than external pipe diameter.
 - 3. All Rated Openings: Caulked tight with fire stopping material in compliance with ASTM E814 in accordance with Section 07 84 00 to prevent the spread of fire, smoke, and gases.

2.2 PIPE-SLEEVE SEALS

- A. Modular Mechanical Sleeve-Seal:
 - 1. Elastomer-based interlocking links continuously fill annular space between pipe and wall-sleeve, wall or casing opening.
 - 2. Watertight seal between pipe and wall-sleeve, wall or casing opening.
 - 3. Size and select seal component materials in accordance with service requirements.

4. Glass-reinforced plastic pressure end plates.
- B. Sealing Compounds:
 1. Provide packing and sealing compound to fill pipe to sleeve thickness.
 2. Combined packing and seal compound is to match partition fire-resistance hourly rating.
- C. Pipe Sleeve Material:
 1. Bearing Walls: Steel, cast iron, or terra-cotta pipe.
 2. Masonry Structures: Sheet metal or fiber.
- D. Wall Sleeve: PVC material with waterstop collar, and nailer end-caps.
- E. Sleeve-Forming Disk: Non-conductive plastic-based material, 3 inch thick.
- F. Pipeline-Casing Seals:
 1. End Seals: 1/8 inch, pull-on type, rubber or synthetic rubber based.

PART 3 EXECUTION

3.1 INSTALLATION

- A. Route piping in orderly manner, plumb and parallel to building structure. Maintain gradient.
- B. Install piping to conserve building space, to not interfere with use of space and other work.
- C. Install piping and pipe sleeves to allow for expansion and contraction without stressing pipe, joints, or connected equipment.
- D. Provide sleeves when penetrating footings, floors, walls, partitions, and _____. Seal pipe including sleeve penetrations to achieve fire resistance equivalent to fire separation required.
- E. Manufactured Sleeve-Seal Systems:
 1. Install manufactured sleeve-seal systems in sleeves located in grade slabs and exterior concrete walls at piping entrances into building.
 2. Provide sealing elements of the size, quantity, and type required for the piping and sleeve inner diameter or penetration diameter.
 3. Locate piping in center of sleeve or penetration.
 4. Install field assembled sleeve-seal system components in annular space between sleeve and piping.
 5. Tighten bolting for a water-tight seal.
 6. Install in accordance with manufacturer's recommendations.
- F. When installing more than one piping system material, ensure system components are compatible and joined to ensure the integrity of the system. Provide necessary joining fittings. Ensure flanges, union, and couplings for servicing are consistently provided.

3.2 CLEANING

- A. Upon completion of work, clean all parts of the installation.

Intersect Studio, LLC
23046

Kalamazoo Crosstown
Parkway Facility
Kalamazoo, Michigan

- B. Clean equipment, pipes, valves, and fittings of grease, metal cuttings, and sludge that may have accumulated from the installation and testing of the system.

END OF SECTION

This page intentionally left blank

SECTION 23 05 23 - GENERAL-DUTY VALVES FOR HVAC PIPING

PART 1 GENERAL

1.1 SECTION INCLUDES

- A. Angle valves.
- B. Globe valves.
- C. Ball valves.
- D. Check valves.
- E. Gate valves.

1.2 RELATED REQUIREMENTS

1.3 REFERENCE STANDARDS

- A. ASME B1.20.1 - Pipe Threads, General Purpose, Inch; 2013 (Reaffirmed 2018).
- B. ASME B16.5 - Pipe Flanges and Flanged Fittings: NPS 1/2 Through NPS 24 Metric/Inch Standard; 2025.
- C. ASME B16.10 - Face-to-Face and End-to-End Dimensions of Valves; 2022, with Errata (2023).
- D. ASME B16.18 - Cast Copper Alloy Solder Joint Pressure Fittings; 2021.
- E. ASME B16.34 - Valves — Flanged, Threaded, and Welding End; 2025.
- F. ASME B31.1 - Power Piping; 2024.
- G. ASME B31.9 - Building Services Piping; 2020.
- H. ASTM B62 - Standard Specification for Composition Bronze or Ounce Metal Castings; 2017.
- I. MSS SP-80 - Bronze Gate, Globe, Angle, and Check Valves; 2019.
- J. MSS SP-110 - Ball Valves Threaded, Socket-Welding, Solder Joint, Grooved and Flared Ends; 2010, with Errata .

1.4 SUBMITTALS

- A. See Section 01 30 00 - Administrative Requirements for submittal procedures.
- B. Product Data: Provide data on valves including manufacturers catalog information. Submit performance ratings, rough-in details, weights, support requirements, and piping connections.

PART 2 PRODUCTS

2.1 APPLICATIONS

- A. Listed pipe sizes shown using nominal pipe sizes (NPS) and nominal diameter (DN).
- B. Provide the following valves for the applications if not indicated on drawings:

1. Throttling (Hydronic): Butterfly, Ball, Globe, and Angle.
2. Isolation (Shutoff): Butterfly, Gate, Ball, and Plug.
3. Swing Check (Pump Outlet):
 - a. Size 2 inch and Smaller: Bronze with bronze disc.
 - b. Size 2-1/2 inch and Larger: Iron with lever and weight, lever and spring, center-guided metal, or center-guided with resilient seat.
- C. Substitutions of valves with higher CWP classes or WSP ratings for same valve types are permitted when specified CWP ratings or WSP classes are not available.
- D. Heating Hot Water Valves:
 1. Size 2 inch and Smaller, Brass and Bronze Valves:
 - a. Threaded ends.
 - b. Angle: Bronze disc, Class 125.
 - c. Ball: Full port, one piece, brass trim.
 - d. Swing Check: Bronze disc, Class 125.
 - e. Gate: NRS, Class 125.
 - f. Globe: Bronze disc, Class 125.
 2. Size 2-1/2 inch and Larger, Iron Valves:
 - a. 2-1/2 inch to 4 inch: Threaded ends.
 - b. Single-Flange Butterfly: 2-1/2 inch to 12 inch, aluminum-bronze disc, EPDM seat, 200 CWP.
 - c. Single-Flange Butterfly: 14 inch to 24 inch, aluminum-bronze disc, EPDM seat, 150 CWP.
 - d. Swing Check: Metal seats, Class 125.
 - e. Gate: NRS, Class 125.
 - f. Globe: 2-1/2 inch to 12 inch, Class 125.

2.2 GENERAL REQUIREMENTS

- A. Valve Pressure and Temperature Ratings: No less than rating indicated; as required for system pressures and temperatures.
- B. Valve Sizes: Match upstream piping unless otherwise indicated.
- C. Valve Actuator Types:
 1. Hand Lever: Quarter-turn valves 6 inch and smaller.
- D. Valves in Insulated Piping: Provide 2 inch stem extensions and the following features:
 1. Gate Valves: Rising stem.

2. Ball Valves: Extended operating handle of non-thermal-conductive material, and protective sleeve that allows operation of valve without breaking the vapor seal or disturbing insulation.
3. Butterfly Valves: Extended neck.
- E. Memory Stops: Fully adjustable after insulation is installed.
- F. Valve-End Connections:
 1. Threaded End Valves: ASME B1.20.1.
 2. Pipe Flanges and Flanged Fittings 1/2 inch through 24 inch: ASME B16.5.
 3. Solder Joint Connections: ASME B16.18.
- G. General ASME Compliance:
 1. Ferrous Valve Dimensions and Design Criteria: ASME B16.10 and ASME B16.34.
 2. Power Piping Valves: ASME B31.1.
 3. Building Services Piping Valves: ASME B31.9.

2.3 BRONZE, ANGLE VALVES

- A. CWP Rating: Class 125: 200 psi and Class 150: 300 psi:
 1. Comply with MSS SP-80, Type 1.
 2. Body: Bronze; ASTM B62, with integral seat and screw in bonnet.
 3. Ends: Threaded.
 4. Stem: Bronze.
 5. Disc: Bronze, PTFE, or TFE.
 6. Packing: Asbestos free.
 7. Handwheel: Bronze or aluminum.

2.4 BRONZE, GLOBE VALVES

- A. CWP Rating: Class 125: 200 psi:
 1. Comply with MSS SP-80, Type 1.
 2. Body: Bronze; ASTM B62, with integral seat and screw in bonnet.
 3. Ends: Threaded or solder joint.
 4. Stem and Disc: Bronze or PTFE.
 5. Packing: Asbestos free.
 6. Handwheel: Malleable iron.

2.5 BRONZE, GLOBE VALVES

- A. Ratings for Class 125 and Class 250:
 1. Class 125:

- a. WOG Rating: 200 psi.
- b. WSP Rating: 125 psi, saturated.
2. Class 250: WOG Rating; 300 psi.
3. Comply with MSS SP-80, Type 1.
4. Body: ASTM B62, bronze with integral seat and screw-in bonnet.
5. End Connections: Threaded or solder.
6. Bonnet: NRS; Nonrising Stem.
7. Nonrising Stem: Bronze.
8. Disc: PTFE.
9. Packing: Asbestos free.
10. Handwheel Operator: Malleable Iron.

2.6 BRASS, BALL VALVES

- A. Two Piece, Full Port with Stainless Steel Trim and Female Thread, Male thread, or Solder Connections:
 1. Comply with MSS SP-110.
 2. SWP Rating: 150 psi.
 3. WOG Rating: 600 psi.
 4. Vacuum Rating: 28.9 in-Hg.
 5. Body: Forged brass.
 6. Seats: PTFE.
 7. Stem: Stainless Steel.
 8. Ball: Chrome-plated brass.

2.7 BRONZE, BALL VALVES

- A. General:
 1. Fabricate from dezincification resistant material.
 2. Copper alloys containing more than 15 percent zinc are not permitted.
- B. Two Piece, Full Port with Bronze or Brass Trim:
 1. Comply with MSS SP-110.
 2. WSP Rating: 150 psi.
 3. WOG Rating: 400 psi.
 4. Body: Forged bronze or dezincified-brass alloy.
 5. End Connections: Pipe thread or solder.
 6. Seats: PTFE.

2.8 BRONZE, SWING CHECK VALVES

A. Class 150:

1. Pressure and Temperature Rating: MSS SP-80, Type 3.
2. Design: Y-pattern, horizontal or vertical flow.
3. CWP Rating: 300 psi.
4. Body: Bronze, ASTM B62.
5. End Connections: Threaded or soldered.
6. Disc: Bronze.

2.9 BRONZE, GATE VALVES

A. Rising Stem or OS&Y:

1. Pressure-Temperature Range: MSS SP-80, Type I.
2. Body: ASTM B62, bronze with integral seat and screw-in bonnet.
3. End Connections: Threaded or solder.
4. Stem: Bronze.
5. Disc: Solid wedge; bronze.
6. Packing: Asbestos free.
7. Handwheel Operator: Malleable iron, bronze, or aluminum.

PART 3 EXECUTION

3.1 EXAMINATION

- A. Discard all packing materials and verify that valve interior, including threads and flanges, are completely clean without signs of damage or degradation that could result in leakage.
- B. Verify valve parts to be fully operational in all positions from closed to fully open.
- C. Confirm gasket material to be suitable for the service, to be of correct size, and without defects that could compromise effectiveness.
- D. Should valve is determined to be defective, replace with new valve.

3.2 INSTALLATION

- A. Provide unions or flanges with valves to facilitate equipment removal and maintenance while maintaining system operation and full accessibility for servicing.
- B. Provide separate valve support as required and locate valve with stem at or above center of piping, maintaining unimpeded stem movement.
- C. Install check valves where necessary to maintain direction of flow as follows:
 1. Swing Check: Install horizontal maintaining hinge pin level.

GENERAL-DUTY VALVES FOR HVAC PIPINGIntersect Studio,
LLC
23046

Kalamazoo Crosstown
Parkway Facility
Kalamazoo, Michigan

END OF SECTION

SECTION 23 05 29 - HANGERS AND SUPPORTS FOR HVAC PIPING AND EQUIPMENT

PART 1 GENERAL

1.1 SECTION INCLUDES

- A. Support and attachment components.

1.2 DELIVERY, STORAGE, AND HANDLING

- A. Receive, inspect, handle, and store products in accordance with manufacturer's instructions.

PART 2 PRODUCTS

2.1 SUPPORT AND ATTACHMENT COMPONENTS

A. General Requirements:

1. Provide all required hangers, supports, anchors, fasteners, fittings, accessories, and hardware as necessary for the complete installation of plumbing work.
2. Provide products listed, classified, and labeled as suitable for the purpose intended, where applicable.
3. Where support and attachment component types and sizes are not indicated, select in accordance with manufacturer's application criteria as required for the load to be supported with a minimum safety factor of _____. Include consideration for vibration, equipment operation, and shock loads where applicable.
4. Steel Components: Use corrosion resistant materials suitable for the environment where installed.
 - a. Zinc-Plated Steel: Electroplated in accordance with ASTM B633.
 - b. Galvanized Steel: Hot-dip galvanized after fabrication in accordance with ASTM A123/A123M or ASTM A153/A153M.

B. Prefabricated Trapeze-Framed Metal Strut Systems:

1. Strut Channel or Bracket Material:
2. Accessories: Provide bracket covers, cable basket clips, cable tray clips, clamps, conduit clamps, fire-retarding brackets, j-hooks, protectors, and vibration dampeners.

C. Hanger Rods:

1. Threaded zinc-plated steel unless otherwise indicated.
2. Minimum Size, Unless Otherwise Indicated or Required:
 - a. Equipment Supports: 1/2 inch diameter.
 - b. Piping up to 1 inch: 1/4 inch diameter.
 - c. Piping larger than 1 inch: 3/8 inch diameter.

- d. Trapeze Support for Multiple Pipes: 3/8 inch diameter.
- D. Thermal Insulated Pipe Supports:
1. General Requirements:
 - a. Insulated pipe supports to be provided at hanger, support, and guide locations on pipe requiring insulation or additional support.
 - b. Surface Burning Characteristics: Flame spread index/smoke developed index of 5/30, maximum, when tested in accordance with ASTM E84 or UL 723.
 - c. Pipe supports to be provided for nominally sized, 1/2 to 30 inch iron pipes.
 - d. Insulation inserts to consist of rigid polyisocyanurate (urethane) insulation surrounded by a 360 degree, PVC jacketing.
 2. PVC Jacket:
 - a. Pipe insulation protection shields to be provided with a ball bearing hinge and locking seam.
 - b. Moisture Vapor Transmission: 0.0071 perm inch, when tested in accordance with ASTM E96/E96M.
 - c. Thickness: 60 mil.
- E. Pipe Supports:
1. Material: ASTM A395/A395M ductile iron, ASTM A36/A36M carbon steel, ASTM A47/A47M malleable iron, ASTM A181/A181M forged steel, or ASTM A283/A283M steel.
 2. Liquid Temperatures Up To 122 degrees F:
 - a. Overhead Support: MSS SP-58 Types 1, 3 through 12.
 - b. Support From Below: MSS SP-58 Types 35 through 38.
- F. Beam Clamps:
1. MSS SP-58 types 19 through 23, 25 or 27 through 30 based on required load.
 2. Beam C-Clamp: MSS SP-58 type 23, malleable iron and steel with plain, stainless steel, and zinc finish.
 3. Small or Junior Beam Clamp: MSS SP-58 type 19, malleable iron with plain finish. For inverted usage provide manufacturer listed size(s).
 4. Wide Mouth Beam Clamp: MSS SP-58 type 19, malleable iron with plain finish.
 5. Centerload Beam Clamp with Extension Piece: MSS SP-58 type 30, malleable iron with plain finish.
 6. FM (AG) and UL (DIR) Approved Beam Clamp: MSS SP-58 type 19, plain finish,
 7. Provide clamps with hardened steel cup-point set screws and lock-nuts for anchoring in place.
 8. Material: ASTM A395/A395M ductile iron, ASTM A36/A36M carbon steel, ASTM A47/A47M malleable iron, ASTM A181/A181M forged steel, or ASTM A283/A283M steel.

G. Pipe Hangers:

1. Split Ring Hangers:
 - a. Provide hinged split ring and yoke roller hanger with epoxy copper or plain finish.
 - b. Material: ASTM A47/A47M malleable iron or ASTM A36/A36M carbon steel.
 - c. Provide hanger rod and nuts of the same type and material for a given pipe run.
 - d. Provide coated or plated hangers to isolate steel hangers from dissimilar metal tube or pipe.
2. Swivel Ring Hangers, Adjustable:
 - a. MSS SP-58 Type 10, epoxy-painted, zinc-colored.
 - b. Material: ASTM A395/A395M ductile iron, ASTM A36/A36M carbon steel, ASTM A47/A47M malleable iron, ASTM A181/A181M forged steel, or ASTM A283/A283M steel.
 - c. FM (AG) and UL (DIR) listed for specific pipe size runs and loads.
3. Clevis Hangers, Adjustable:
 - a. Copper Tube: MSS SP-58 Type 1, epoxy-plated copper.
 - b. Felt-Lined: MSS SP-58 Type 1, zinc-plated, silicone-free carbon steel.
 - c. Light-Duty: MSS SP-58 Type 1, zinc-colored, epoxy plated.
 - d. Standard-Duty: MSS SP-58 Type 1, zinc-colored, epoxy plated.

H. Intermediate Pipe Guides:

1. Pipe Diameter 6 inch and Smaller: Provide minimum clearance of 0.16 inch.
2. Pipe Sizes 8 inch: 0.625 inch U-bolt with double nuts providing minimum clearance of 0.28 inch.
3. Pipe Size 10 inch: 0.75 inch U-bolt.
4. Pipe Sizes 12 to 16 inch: 0.875 inch U-bolt.
5. Pipe Sizes 18 to 30 inch: 1 inch U-bolt.
6. Use pipe clamps with oversize pipe sleeve that provides clearance around pipe.

I. Pipe Alignment Guides:

1. Pipe Sizes 8 inch and Smaller: Spider or sleeve type.
2. Pipe Sizes 10 inch and Larger: Roller type.

J. Pipe Shields for Insulated Piping:

1. General Construction and Requirements:
 - a. Surface Burning Characteristics: Comply with ASTM E84 or UL 723.
 - b. Shields Material: UV-resistant polypropylene with glass fill.
 - c. Maximum Insulated Pipe Outer Diameter: 12-5/8 inch.

- d. Minimum Service Temperature: Minus 40 degrees F.
 - e. Maximum Service Temperature: 178 degrees F.
 - f. Pipe shields to be provided at hanger, support, and guide locations on pipe requiring insulation or additional support.
- K. Anchors and Fasteners:
- 1. Unless otherwise indicated and where not otherwise restricted, use the anchor and fastener types indicated for the specified applications.

PART 3 EXECUTION

3.1 EXAMINATION

- A. Verify that field measurements are as indicated.
- B. Verify that mounting surfaces are ready to receive support and attachment components.
- C. Verify that conditions are satisfactory for installation prior to starting work.

3.2 INSTALLATION

- A. Install products in accordance with manufacturer's instructions.
- B. Provide independent support from building structure. Do not provide support from piping, ductwork, conduit, or other systems.
- C. Unless specifically indicated or approved by Architect, do not provide support from suspended ceiling support system or ceiling grid.
- D. Unless specifically indicated or approved by Architect, do not provide support from roof deck.
- E. Do not penetrate or otherwise notch or cut structural members without approval of Structural Engineer.
- F. Provide thermal insulated pipe supports complete with hangers and accessories. Install thermal insulated pipe supports during the installation of the piping system.
- G. Equipment Support and Attachment:
 - 1. Use metal fabricated supports or supports assembled from metal channel (strut) to support equipment as required.
 - 2. Use metal channel (strut) secured to studs to support equipment surface-mounted on hollow stud walls when wall strength is not sufficient to resist pull-out.
 - 3. Use metal channel (strut) to support surface-mounted equipment in wet or damp locations to provide space between equipment and mounting surface.
 - 4. Securely fasten floor-mounted equipment. Do not install equipment such that it relies on its own weight for support.
- H. Secure fasteners according to manufacturer's recommended torque settings.

Intersect Studio, LLC
23046

Kalamazoo Crosstown
Parkway Facility
Kalamazoo, Michigan

- I. Remove temporary supports.

END OF SECTION

This page intentionally left blank

SECTION 23 05 53 - IDENTIFICATION FOR HVAC PIPING AND EQUIPMENT

PART 1 GENERAL

1.1 SECTION INCLUDES

- A. Nameplates.
- B. Tags.
- C. Adhesive-backed duct markers.
- D. Stencils.
- E. Pipe markers.
- F. Ceiling tacks.

1.2 RELATED REQUIREMENTS

- A. Section 09 91 23 - Interior Painting: Identification painting.

1.3 REFERENCE STANDARDS

- A. ASME A13.1 - Scheme for the Identification of Piping Systems; 2023.
- B. ASTM D709 - Standard Specification for Laminated Thermosetting Materials; 2017.

1.4 SUBMITTALS

- A. See Section 01 30 00 - Administrative Requirements for submittal procedures.
- B. Product Data: Provide manufacturers catalog literature for each product required.

PART 2 PRODUCTS

2.1 IDENTIFICATION APPLICATIONS

- A. Air Terminal Units: Tags.
- B. Automatic Controls: Tags. Key to control schematic.
- C. Control Panels: Nameplates.
- D. Ductwork: Stencilled painting.
- E. Instrumentation: Tags.
- F. Thermostats: Nameplates.

2.2 NAMEPLATES

- A. Letter Color: White.
- B. Letter Height: 1/4 inch.
- C. Background Color: Black.

- D. Plastic: Comply with ASTM D709.

2.3 TAGS

- A. Metal Tags: Brass with stamped letters; tag size minimum 1-1/2 inch diameter with smooth edges.

2.4 ADHESIVE-BACKED DUCT MARKERS

- A. Material: High gloss acrylic adhesive-backed vinyl film 0.0032 inch; printed with UV and chemical resistant inks.
- B. Style: Individual Label.
- C. Color: Yellow/Black.

2.5 STENCILS

- A. Stencils: With clean cut symbols and letters of following size:
 1. 3/4 to 1-1/4 inch Outside Diameter of Insulation or Pipe: 8 inch long color field, 1/2 inch high letters.
 2. 1-1/2 to 2 inch Outside Diameter of Insulation or Pipe: 8 inch long color field, 3/4 inch high letters.
 3. 2-1/2 to 6 inch Outside Diameter of Insulation or Pipe: 12 inch long color field, 1-1/4 inch high letters.
 4. Ductwork and Equipment: 2-1/2 inch high letters.
- B. Stencil Paint: As specified in Section 09 91 23, semi-gloss enamel, colors complying with ASME A13.1.

2.6 PIPE MARKERS

- A. Color: Comply with ASME A13.1.
- B. Plastic Pipe Markers: Factory fabricated, flexible, semi-rigid plastic, preformed to fit around pipe or pipe covering; minimum information indicating flow direction arrow and identification of fluid being conveyed.

2.7 CEILING TACKS

- A. Description: Steel with 3/4 inch diameter color coded head.
- B. Color code as follows:
 1. HVAC Equipment: Yellow.
 2. Fire Dampers and Smoke Dampers: Red.
 3. Heating/Cooling Valves: Blue.

PART 3 EXECUTION

3.1 PREPARATION

- A. Degrease and clean surfaces to receive adhesive for identification materials.
- B. Prepare surfaces in accordance with Section 09 91 23 for stencil painting.

3.2 INSTALLATION

- A. Install nameplates with corrosive-resistant mechanical fasteners, or adhesive. Apply with sufficient adhesive to ensure permanent adhesion and seal with clear lacquer.
- B. Install tags with corrosion resistant chain.
- C. Apply stencil painting in accordance with Section 09 91 23.
- D. Install plastic tape pipe markers complete around pipe in accordance with manufacturer's instructions.
- E. Use tags on piping 3/4 inch diameter and smaller.
 - 1. Identify service, flow direction, and pressure.
 - 2. Install in clear view and align with axis of piping.
- F. Locate ceiling tacks to locate valves or dampers above lay-in panel ceilings. Locate in corner of panel closest to equipment.

END OF SECTION

This page intentionally left blank

SECTION 23 05 93 - TESTING, ADJUSTING, AND BALANCING FOR HVAC

PART 1 GENERAL

1.1 SECTION INCLUDES

- A. Testing, adjustment, and balancing of air systems.

1.2 RELATED REQUIREMENTS

- A. Section 01 40 00 - Quality Requirements: Employment of testing agency and payment for services.

1.3 REFERENCE STANDARDS

- A. ASHRAE Std 111 - Measurement, Testing, Adjusting, and Balancing of Building HVAC Systems; 2024.
- B. SMACNA (TAB) - HVAC Systems Testing, Adjusting and Balancing; 2023.

1.4 SUBMITTALS

- A. See Section 01 30 00 - Administrative Requirements, for submittal procedures.
- B. Final Report: Indicate deficiencies in systems that would prevent proper testing, adjusting, and balancing of systems and equipment to achieve specified performance.
 - 1. Revise TAB plan to reflect actual procedures and submit as part of final report.
 - 2. Submit draft copies of report for review prior to final acceptance of Project. Provide final copies for Architect and for inclusion in operating and maintenance manuals.
 - 3. Include actual instrument list, with manufacturer name, serial number, and date of calibration.
 - 4. Form of Test Reports: Where the TAB standard being followed recommends a report format use that; otherwise, follow ASHRAE Std 111.
 - 5. Units of Measure: Report data in both I-P (inch-pound) and SI (metric) units.

PART 2 PRODUCTS - NOT USED

PART 3 EXECUTION

3.1 GENERAL REQUIREMENTS

- A. Perform total system balance in accordance with one of the following:
 - 1. SMACNA (TAB).
- B. Begin work after completion of systems to be tested, adjusted, or balanced and complete work prior to Substantial Completion of the project.
- C. TAB Agency Qualifications:

1. Company specializing in the testing, adjusting, and balancing of systems specified in this section.
2. Certified by one of the following:
 - a. AABC, Associated Air Balance Council: www.aabc.com/#sle; upon completion submit AABC National Performance Guaranty.
 - b. NEBB, National Environmental Balancing Bureau: www.nebb.org/#sle.
 - c. TABB, The Testing, Adjusting, and Balancing Bureau of National Energy Management Institute: www.tabbcertified.org/#sle.
- D. TAB Supervisor and Technician Qualifications: Certified by same organization as TAB agency.

3.2 EXAMINATION

- A. Verify that systems are complete and operable before commencing work. Ensure the following conditions:
 1. Systems are started and operating in a safe and normal condition.
 2. Temperature control systems are installed complete and operable.
 3. Proper thermal overload protection is in place for electrical equipment.
 4. Final filters are clean and in place. If required, install temporary media in addition to final filters.
 5. Duct systems are clean of debris.
 6. Fans are rotating correctly.
 7. Fire and volume dampers are in place and open.
 8. Air coil fins are cleaned and combed.
 9. Access doors are closed and duct end caps are in place.
 10. Air outlets are installed and connected.
 11. Duct system leakage is minimized.
 12. Service and balance valves are open.
- B. Beginning of work means acceptance of existing conditions.

3.3 ADJUSTMENT TOLERANCES

- A. Air Handling Systems: Adjust to within plus or minus 5 percent of design for supply systems and plus or minus 10 percent of design for return and exhaust systems.
- B. Air Outlets and Inlets: Adjust total to within plus 10 percent and minus 5 percent of design to space. Adjust outlets and inlets in space to within plus or minus 10 percent of design.

3.4 RECORDING AND ADJUSTING

- A. Ensure recorded data represents actual measured or observed conditions.
- B. Permanently mark settings of valves, dampers, and other adjustment devices allowing settings to be restored. Set and lock memory stops.

- C. Mark on drawings the locations where traverse and other critical measurements were taken and cross reference the location in the final report.
- D. After adjustment, take measurements to verify balance has not been disrupted or that such disruption has been rectified.
- E. Leave systems in proper working order, replacing belt guards, closing access doors, closing doors to electrical switch boxes, and restoring thermostats to specified settings.

3.5 AIR SYSTEM PROCEDURE

- A. Adjust air handling and distribution systems to provide required or design supply, return, and exhaust air quantities at site altitude.
- B. Make air quantity measurements in ducts by Pitot tube traverse of entire cross sectional area of duct.
- C. Measure air quantities at air inlets and outlets.
- D. Adjust distribution system to obtain uniform space temperatures free from objectionable drafts and noise.
- E. Use volume control devices to regulate air quantities only to extend that adjustments do not create objectionable air motion or sound levels. Effect volume control by duct internal devices such as dampers and splitters.
- F. Vary total system air quantities by adjustment of fan speeds. Provide drive changes required. Vary branch air quantities by damper regulation.
- G. Measure static air pressure conditions on air supply units, including filter and coil pressure drops, and total pressure across the fan. Make allowances for 50 percent loading of filters.
- H. Adjust outside air automatic dampers, outside air, return air, and exhaust dampers for design conditions.

3.6 WATER SYSTEM PROCEDURE

- A. Adjust water systems to provide required or design quantities.
- B. Use calibrated Venturi tubes, orifices, or other metered fittings and pressure gages to determine flow rates for system balance. Where flow metering devices are not installed, base flow balance on temperature difference across various heat transfer elements in the system.
- C. Adjust systems to provide specified pressure drops and flows through heat transfer elements prior to thermal testing. Perform balancing by measurement of temperature differential in conjunction with air balancing.
- D. Effect system balance with automatic control valves fully open to heat transfer elements.
- E. Effect adjustment of water distribution systems by means of balancing cocks, valves, and fittings. Do not use service or shut-off valves for balancing unless indexed for balance point.
- F. Where available pump capacity is less than total flow requirements or individual system parts, full flow in one part may be simulated by temporary restriction of flow to other parts.

TESTING, ADJUSTING, AND BALANCING FOR HVAC
Intersect
Studio, LLC
23046

Kalamazoo Crosstown
Parkway Facility
Kalamazoo, Michigan

3.7 SCOPE

- A. Test, adjust, and balance the following:
1. Plumbing Pumps.
 2. HVAC Pumps.
 3. Packaged Roof Top Heating/Cooling Units.
 4. Packaged Terminal Air Conditioning Units.
 5. Fans.
 6. Air Terminal Units.
 7. Air Inlets and Outlets.

END OF SECTION

SECTION 23 07 13 - DUCT INSULATION

PART 1 GENERAL

1.1 SECTION INCLUDES

- A. Duct insulation.
- B. Duct liner.
- C. Insulation jackets.

1.2 RELATED REQUIREMENTS

- A. Section 07 84 00 - Firestopping.
- B. Section 22 05 53 - Identification for Plumbing Piping and Equipment.
- C. Section 23 05 53 - Identification for HVAC Piping and Equipment.
- D. Section 23 31 00 - HVAC Ducts and Casings: Glass fiber ducts.

1.3 SUBMITTALS

- A. See Section 01 30 00 - Administrative Requirements, for submittal procedures.
- B. Product Data: Provide product description, thermal characteristics, list of materials and thickness for each service, and locations.

1.4 DELIVERY, STORAGE, AND HANDLING

- A. Accept materials on site in original factory packaging, labelled with manufacturer's identification, including product density and thickness.
- B. Protect insulation from weather and construction traffic, dirt, water, chemical, and mechanical damage, by storing in original wrapping.

1.5 FIELD CONDITIONS

- A. Maintain ambient temperatures and conditions required by manufacturers of adhesives, mastics, and insulation cements.
- B. Maintain temperature during and after installation for minimum period of 24 hours.

PART 2 PRODUCTS

2.1 REGULATORY REQUIREMENTS

- A. Surface Burning Characteristics: Flame spread index/Smoke developed index of 25/50, maximum, when tested in accordance with ASTM E84 or UL 723.

2.2 GLASS FIBER, FLEXIBLE

- A. Insulation: ASTM C553; flexible, noncombustible blanket.

1. K value: 0.36 at 75 degrees F, when tested in accordance with ASTM C518.
 2. Maximum Service Temperature: 1200 degrees F.
 3. Maximum Water Vapor Absorption: 5.0 percent by weight.
- B. Vapor Barrier Jacket:
1. Kraft paper with glass fiber yarn and bonded to aluminized film.
 2. Moisture Vapor Permeability: 0.02 perm inch, when tested in accordance with ASTM E96/E96M.
 3. Secure with pressure sensitive tape.
- C. Vapor Barrier Tape:
1. Kraft paper reinforced with glass fiber yarn and bonded to aluminized film, with pressure sensitive rubber based adhesive.
- D. Indoor Vapor Barrier Mastic:
1. Vinyl emulsion type acrylic or mastic, compatible with insulation, black color.
- E. Outdoor Vapor Barrier Mastic:
1. Vinyl emulsion type acrylic or mastic, compatible with insulation, black color.
- F. Tie Wire: Annealed steel, 16 gage, 0.0508 inch diameter.

2.3 GLASS FIBER, RIGID

- A. Insulation: ASTM C612; rigid, noncombustible blanket.
1. K Value: 0.24 at 75 degrees F, when tested in accordance with ASTM C518.
 2. Maximum Service Temperature: 450 degrees F.
 3. Maximum Water Vapor Absorption: 5.0 percent.
- B. Vapor Barrier Jacket:
1. Kraft paper with glass fiber yarn and bonded to aluminized film.
 2. Moisture Vapor Permeability: 0.02 perm inch, when tested in accordance with ASTM E96/E96M.
 3. Secure with pressure sensitive tape.
- C. Vapor Barrier Tape:
1. Kraft paper reinforced with glass fiber yarn and bonded to aluminized film, with pressure sensitive rubber based adhesive.

2.4 JACKETS

- A. Flexible Weather-Proofing Outdoor Jacket: Self-healing, field-applied outdoor cladding.
1. Material: Aluminum foil/polymer laminate with rubberized asphalt layer and acrylic adhesive.
 2. Thickness: 34 mils.

3. Finish: Embossed.
4. Color: Silver.
5. Water Vapor Transmission: 0.002 perm inch, maximum, when tested in accordance with ASTM E96/E96M.
6. Mold Resistance: Pass when tested in accordance with ASTM C1338.
7. Emissivity: 0.30 when tested in accordance with ASTM C1371.

2.5 DUCT LINER

- A. Glass Fiber Insulation: Non-corrosive, incombustible glass fiber complying with ASTM C1071; flexible blanket, rigid board, and preformed round liner board; impregnated surface and edges coated with poly vinyl acetate polymer, acrylic polymer, or black composite.
 1. Fungal Resistance: No growth when tested according to ASTM G21.
 2. Apparent Thermal Conductivity: Maximum of 0.31 at 75 degrees F.
 3. Service Temperature: Up to 250 degrees F.
 4. Rated Velocity on Coated Air Side for Air Erosion: 5,000 fpm, minimum.
- B. Adhesive: Waterproof, fire-retardant type, ASTM C916.

PART 3 EXECUTION

3.1 EXAMINATION

- A. Test ductwork for design pressure prior to applying insulation materials.
- B. Verify that surfaces are clean, foreign material removed, and dry.

3.2 INSTALLATION

- A. Install in accordance with manufacturer's instructions.
- B. Insulated Ducts Conveying Air Below Ambient Temperature:
 1. Provide insulation with vapor barrier jackets.
 2. Finish with tape and vapor barrier jacket.
 3. Continue insulation through walls, sleeves, hangers, and other duct penetrations.
- C. Insulated Ducts Conveying Air Above Ambient Temperature:
 1. Provide with or without standard vapor barrier jacket.
- D. Exterior Applications: Provide insulation with vapor barrier jacket. Cover with calked aluminum jacket with seams located on bottom side of horizontal duct section.
- E. Slope exterior ductwork to shed water.
- F. External Duct Insulation Application:
 1. Secure insulation with vapor barrier with wires and seal jacket joints with vapor barrier adhesive or tape to match jacket.

2. Install without sag on underside of duct. Use adhesive or mechanical fasteners where necessary to prevent sagging. Lift duct off trapeze hangers and insert spacers.
- G. Duct and Plenum Liner Application:
1. Adhere insulation with adhesive for 90 percent coverage.
 2. Secure insulation with mechanical liner fasteners. Refer to SMACNA (DCS) for spacing.
 3. Seal and smooth joints. Seal and coat transverse joints.
 4. Seal liner surface penetrations with adhesive.

END OF SECTION

SECTION 23 07 19 - HVAC PIPING INSULATION

PART 1 GENERAL

1.1 SECTION INCLUDES

- A. Piping insulation.
- B. Flexible removable and reusable blanket insulation.

1.2 RELATED REQUIREMENTS

- A. Section 07 84 00 - Firestopping.

1.3 SUBMITTALS

- A. See Section 01 30 00 - Administrative Requirements for submittal procedures.
- B. Product Data: Provide product description, thermal characteristics, list of materials and thickness for each service, and locations.

1.4 DELIVERY, STORAGE, AND HANDLING

- A. Accept materials on site, labeled with manufacturer's identification, product density, and thickness.

PART 2 PRODUCTS

2.1 REGULATORY REQUIREMENTS

- A. Surface Burning Characteristics: Flame spread index/Smoke developed index of 25/50, maximum, when tested in accordance with ASTM E84 or UL 723.

2.2 GLASS FIBER, FLEXIBLE

- A. Manufacturers:
- B. Insulation: ASTM C553; flexible, noncombustible blanket.
 - 1. K Value: 0.36 at 75 degrees F, when tested in accordance with ASTM C518.
 - 2. Maximum Service Temperature: 1,200 degrees F.
 - 3. Maximum Water Vapor Absorption: 5.0 percent by weight.
- C. Vapor Barrier Jacket:
 - 1. Kraft paper with glass fiber yarn and bonded to aluminized film.
 - 2. Moisture Vapor Permeability: 0.02 perm inch, when tested in accordance with ASTM E96/E96M.
 - 3. Secure with pressure-sensitive tape.
- D. Vapor Barrier Tape:

1. Kraft paper reinforced with glass fiber yarn and bonded to aluminized film with pressure-sensitive rubber-based adhesive.

2.3 GLASS FIBER, RIGID

- A. Insulation: ASTM C547 and ASTM C795; rigid molded, noncombustible.
 1. K Value: ASTM C177, 0.24 at 75 degrees F.
 2. Maximum Service Temperature: 850 degrees F.
 3. Maximum Moisture Absorption: 0.2 percent by volume.
- B. Insulation: ASTM C547 and ASTM C795; rigid molded, noncombustible, with wicking material to transport condensed water to the outside of the system for evaporation to the atmosphere.
 1. K Value: ASTM C177, 0.23 at 75 degrees F.
 2. Maximum Service Temperature: 220 degrees F.
 3. Maximum Moisture Absorption: 0.2 percent by volume.
- C. Vapor Barrier Jacket: White kraft paper with glass fiber yarn, bonded to aluminized film; moisture vapor transmission when tested in accordance with ASTM E96/E96M of 0.02 perm-inches.
- D. Vapor Barrier Lap Adhesive: Compatible with insulation.
- E. Insulating Cement/Mastic: ASTM C195; hydraulic setting on mineral wool.
- F. Indoor Vapor Barrier Finish:
 1. Cloth: Untreated; 9 oz/sq yd weight.
 2. Vinyl emulsion type acrylic, compatible with insulation, black color.

2.4 CELLULAR GLASS

- A. Pipe and Tubing Insulation: ASTM C552, Type II, Grade 6.
 1. K Value: 0.35 at 100 degrees F.
 2. Service Temperature Range: From 250 degrees F to 800 degrees F.
 3. Water Vapor Permeability: 0.005 perm inch maximum per inch.
 4. Water Absorption: 0.5 percent by volume, maximum.
 5. Density: A minimum of 6.12 pcf.

2.5 POLYISOCYANURATE CELLULAR PLASTIC

- A. Insulation Material: ASTM C591, rigid molded modified polyisocyanurate cellular plastic.
 1. Dimension: Comply with requirements of ASTM C585.
 2. K Value: 0.18 at 75 degrees F, when tested in accordance with ASTM C518.
 3. Minimum Service Temperature: Minus 70 degrees F.
 4. Maximum Service Temperature: 300 degrees F.

5. Water Absorption: 0.5 percent by volume, maximum, when tested in accordance with ASTM D2842.
6. Moisture Vapor Transmission: 4.0 perm inch.
7. Connection: Waterproof vapor barrier adhesive.

2.6 FLEXIBLE ELASTOMERIC CELLULAR INSULATION

- A. Insulation: Preformed flexible elastomeric cellular rubber insulation complying with ASTM C534/C534M Grade 1; use molded tubular material wherever possible.
 1. Minimum Service Temperature: Minus 40 degrees F.
 2. Maximum Service Temperature: 180 degrees F.
 3. Connection: Waterproof vapor barrier adhesive.
- B. Elastomeric Foam Adhesive: Air dried, contact adhesive, compatible with insulation.
- C. Weather Barrier Coating: Air dried, contact adhesive, compatible with insulation and ASTM E84 compliant.

PART 3 EXECUTION

3.1 EXAMINATION

- A. Test piping for design pressure, liquid tightness, and continuity prior to applying insulation materials.
- B. Verify that surfaces are clean and dry, with foreign material removed.

3.2 INSTALLATION

- A. Install in accordance with manufacturer's instructions.
- B. Exposed Piping: Locate insulation and cover seams in least visible locations.
- C. Glass Fiber Insulated Pipes Conveying Fluids Below Ambient Temperature:
 1. Provide vapor barrier jackets, factory-applied or field-applied; secure with self-sealing longitudinal laps and butt strips with pressure-sensitive adhesive. Secure with outward clinch expanding staples and vapor barrier mastic.
 2. Insulate fittings, joints, and valves with molded insulation of like material and thickness as adjacent pipe. Finish with glass cloth and vapor barrier adhesive or PVC fitting covers.
- D. For hot piping conveying fluids 140 degrees F or less, do not insulate flanges and unions at equipment, but bevel and seal ends of insulation.
- E. For hot piping conveying fluids over 140 degrees F, insulate flanges and unions at equipment.
- F. Glass Fiber Insulated Pipes Conveying Fluids Above Ambient Temperature:
 1. Provide standard jackets, with or without vapor barrier, factory-applied, or field-applied. Secure with self-sealing longitudinal laps and butt strips with pressure-sensitive adhesive. Secure with outward clinch expanding staples.

2. Insulate fittings, joints, and valves with insulation of like material and thickness as adjoining pipe. Finish with glass cloth and adhesive or PVC fitting covers.
- G. Inserts and Shields:
1. Application: Piping 1-1/2 inches diameter or larger.
 2. Shields: Galvanized steel between pipe hangers or pipe hanger rolls and inserts.
 3. Insert location: Between support shield and piping and under the finish jacket.
 4. Insert Configuration: Minimum 6 inches long, of same thickness and contour as adjoining insulation; may be factory fabricated.
 5. Insert Material: Hydrous calcium silicate insulation or other heavy density insulating material suitable for the planned temperature range.
- H. Continue insulation through walls, sleeves, pipe hangers, and other pipe penetrations. Finish at supports, protrusions, and interruptions. At fire separations, see Section 07 84 00.
- I. Pipe Exposed in Mechanical Equipment Rooms or Finished Spaces (less than 10 feet above finished floor): Finish with canvas jacket sized for finish painting.
- J. Exterior Applications: Provide vapor barrier jacket. Insulate fittings, joints, and valves with insulation of like material and thickness as adjoining pipe, and finish with glass mesh reinforced vapor barrier cement. Cover with aluminum jacket with seams located on bottom side of horizontal piping. Provide two coats of UV-resistant finish for flexible elastomeric cellular insulation without jacketing.

END OF SECTION

SECTION 23 08 00 - COMMISSIONING OF HVAC

PART 1 GENERAL

1.1 SUMMARY

- A. See Section 01 91 13 - General Commissioning Requirements for overall objectives; comply with the requirements of Section 01 91 13.
- B. This section covers the Contractor's responsibilities for commissioning; each subcontractor or installer responsible for the installation of a particular system or equipment item to be commissioned is responsible for the commissioning activities relating to that system or equipment item.
- C. The Commissioning Provider (CxP) directs and coordinates all commissioning activities and provides Prefunctional Checklists and Functional Test Procedures for Contractor's use.
- D. The following HVAC equipment is to be commissioned, including commissioning activities for the following specific items:
 - 1. Control system.
 - 2. Major and minor equipment items.
 - 3. Piping systems and equipment.
 - 4. Terminal units.
 - 5. Other equipment and systems explicitly identified elsewhere in Contract Documents as requiring commissioning.
- E. The Prefunctional Checklist and Functional Test requirements specified in this section are in addition to, not a substitute for, inspection or testing specified in other sections.

1.2 REFERENCE STANDARDS

- A. ASHRAE Guideline 1.1 - Application of the Commissioning Process to New HVAC&R Systems; 2025.

1.3 SUBMITTALS

- A. Updated Submittals: Keep Commissioning Provider (CxP) informed of all changes to control system documentation made during programming and setup; revise and resubmit when substantial changes are made.
- B. Startup Reports, Prefunctional Checklists, and Trend Logs: Submit for approval of Commissioning Provider.
- C. HVAC Control System O&M Manual Requirements. In addition to documentation specified elsewhere, compile and organize at minimum the following data on the control system:

1. Specific step-by-step instructions on how to perform and apply all functions, features, modes, etc. mentioned in the controls training sections of this specification and other features of this system. Provide an index and clear table of contents. Include the detailed technical manual for programming and customizing control loops and algorithms.
2. Full as-built set of control drawings.
3. Full as-built sequence of operations for each piece of equipment.
4. Full points list; in addition to the information on the original points list submittal, include a listing of all rooms with the following information for each room:
 - a. Floor.
 - b. Room number.
 - c. Room name.
 - d. Air handler unit ID.
 - e. Reference drawing number.
 - f. Air terminal unit tag ID.
 - g. Heating and/or cooling valve tag ID.
 - h. Minimum air flow rate.
 - i. Maximum air flow rate.
5. Full print out of all schedules and set points after testing and acceptance of the system.
6. Full as-built print out of software program.
7. Electronic copy on disk of the entire program for this facility.
8. Marking of all system sensors and thermostats on the as-built floor plan and HVAC drawings with their control system designations.
9. Maintenance instructions, including sensor calibration requirements and methods by sensor type, etc.
10. Control equipment component submittals, parts lists, etc.
11. Warranty requirements.
12. Copies of all checkout tests and calibrations performed by the Contractor (not commissioning tests).
13. Organize and subdivide the manual with permanently labeled tabs for each of the following data in the given order:
 - a. Sequences of operation.
 - b. Control drawings.
 - c. Points lists.
 - d. Controller and/or module data.
 - e. Thermostats and timers.

- f. Sensors and DP switches.
 - g. Valves and valve actuators.
 - h. Dampers and damper actuators.
 - i. Program setups (software program printouts).
- D. Project Record Documents: See Section 01 78 00 for additional requirements.
- 1. Submit updated version of control system documentation, for inclusion with operation and maintenance data.
 - 2. Show actual locations of all static and differential pressure sensors (air, water and building pressure) and air-flow stations on project record drawings.
- E. Draft Training Plan: In addition to requirements specified in Section 01 79 00, include:
- 1. Follow the recommendations of ASHRAE Guideline 1.1.
 - 2. Control system manufacturer's recommended training.
 - 3. Demonstration and instruction on function and overrides of any local packaged controls not controlled by the HVAC control system.
- F. Training Manuals: See Section 01 79 00 for additional requirements.
- 1. Provide three extra copies of the controls training manuals in a separate manual from the O&M manuals.

PART 2 PRODUCTS

2.1 TEST EQUIPMENT

- A. Provide all standard testing equipment required to perform startup and initial checkout and required functional performance testing; unless otherwise noted such testing equipment will NOT become the property of Owner.
- B. Equipment-Specific Tools: Where special testing equipment, tools and instruments are specific to a piece of equipment, are only available from the vendor, and are required in order to accomplish startup or Functional Testing, provide such equipment, tools, and instruments as part of the work at no extra cost to Owner; such equipment, tools, and instruments are to become the property of Owner.

PART 3 EXECUTION

3.1 PREPARATION

- A. Cooperate with CxP in development of the Prefunctional Checklists and Functional Test Procedures.
- B. Furnish additional information requested by CxP.
- C. Prepare a preliminary schedule for HVAC pipe and duct system testing, flushing and cleaning, equipment start-up and testing, adjusting, and balancing start and completion for use by CxP; update the schedule as appropriate.

- D. Notify CxP when pipe and duct system testing, flushing, cleaning, startup of each piece of equipment and testing, adjusting, and balancing will occur; when commissioning activities not yet performed or not yet scheduled will delay construction, notify ahead of time and be proactive in seeing that CxP has the scheduling information needed to efficiently execute the commissioning process.
- E. Put all HVAC equipment and systems into operation and continue operation during each working day of testing, adjusting, and balancing and commissioning, as required.
- F. Provide test holes in ducts and plenums where directed to allow air measurements and air balancing; close with an approved plug.
- G. Provide temperature and pressure taps in accordance with Contract Documents.

3.2 INSPECTING AND TESTING - GENERAL

- A. Submit startup plans, startup reports, and Prefunctional Checklists for each item of equipment or other assembly to be commissioned.
- B. Perform the Functional Tests directed by CxP for each item of equipment or other assembly to be commissioned.
- C. Provide two-way radios for use during the testing.
- D. Valve/Damper Stroke Setup and Check:
 - 1. For all valve/damper actuator positions checked, verify the actual position against the control system readout.
 - 2. Set pump/fan to normal operating mode.
 - 3. Command valve/damper closed; visually verify that valve/damper is closed and adjust output zero signal as required.
 - 4. Command valve/damper open; verify position is full open and adjust output signal as required.
 - 5. Command valve/damper to a few intermediate positions.
 - 6. If actual valve/damper position does not reasonably correspond, replace actuator or add pilot positioner (for pneumatics).
- E. Isolation Valve or System Valve Leak Check: For valves not by coils.
 - 1. With full pressure in the system, command valve closed.
 - 2. Use an ultra-sonic flow meter to detect flow or leakage.
- F. Deficiencies: Correct deficiencies and re-inspect or re-test, as applicable, at no extra cost to Owner.

3.3 TAB COORDINATION

- A. TAB: Testing, adjusting, and balancing of HVAC.
- B. Coordinate commissioning schedule with TAB schedule.
- C. Review the TAB plan to determine the capabilities of the control system toward completing TAB.

- D. Provide all necessary unique instruments and instruct the TAB technicians in their use; such as handheld control system interface for setting terminal unit boxes, etc.
- E. Have all required Prefunctional Checklists, calibrations, startup, and component Functional Tests of the system completed and approved by CxP prior to starting TAB.
- F. Provide a qualified control system technician to operate the controls to assist the TAB technicians or provide sufficient training for the TAB technicians to operate the system without assistance.

3.4 CONTROL SYSTEM FUNCTIONAL TESTING

- A. Prefunctional Checklists for control system components will require a signed and dated certification that all system programming is complete as required to accomplish the requirements of Contract Documents and the detailed Sequences of Operation documentation submittal.
- B. Do not start Functional Testing until all controlled components have themselves been successfully Functionally Tested in accordance with Contract Documents.
- C. Using a skilled technician who is familiar with this building, execute the Functional Testing of the control system as required by CxP.
- D. Functional Testing of the control system constitutes demonstration and trend logging of control points monitored by the control system.
 - 1. The scope of trend logging is partially specified; trend log up to 50 percent more points than specified at no extra cost to Owner.
 - 2. Perform all trend logging specified in Prefunctional Checklists and Functional Test procedures.
- E. Functionally Test integral or stand-alone controls in conjunction with the Functional Tests of the equipment they are attached to, including any interlocks with other equipment or systems; further testing during control system Functional Test is not required unless specifically indicated below.
- F. Demonstrate the following to CxP during testing of controlled equipment; coordinate with commissioning of equipment.
 - 1. Setpoint changing features and functions.
 - 2. Sensor calibrations.
- G. Demonstrate to CxP:
 - 1. That all specified functions and features are set up, debugged and fully operable.
 - 2. That scheduling features are fully functional and setup, including holidays.
 - 3. That all graphic screens and value readouts are completed.
 - 4. Correct date and time setting in central computer.
 - 5. That field panels read the same time as the central computer; sample 10 percent of field panels; if any of those fail, sample another 10 percent; if any of those fail test all remaining units at no extra cost to Owner.

6. Functionality of field panels using local operator keypads and local ports (plug-ins) using portable computer/keypad; demonstrate 100 percent of panels and 10 percent of ports; if any ports fail, sample another 10 percent; if any of those fail, test all remaining units at no extra cost to Owner.
 7. Power failure and battery backup and power-up restart functions.
 8. Global commands features.
 9. Security and access codes.
 10. Occupant over-rides (manual, telephone, key, keypad, etc.).
 11. O&M schedules and alarms.
 12. Occupancy sensors and controls.
 13. All control strategies and sequences not tested during controlled equipment testing.
- H. If the control system, integral control components, or related equipment do not respond to changing conditions and parameters appropriately as expected, as specified and according to acceptable operating practice, under any of the conditions, sequences, or modes tested, correct all systems, equipment, components, and software required at no additional cost to Owner.

3.5 OPERATION AND MAINTENANCE MANUALS

- A. See Section 01 78 00 for additional requirements.
- B. Add design intent documentation furnished by Architect to manuals prior to submission to Owner.
- C. Submit manuals related to items that were commissioned to Commissioning Provider for review; make changes recommended by Commissioning Provider.
- D. Commissioning Provider will add commissioning records to manuals after submission to Owner.

3.6 DEMONSTRATION AND TRAINING

- A. See Section 01 79 00 for additional requirements.
- B. Demonstrate operation and maintenance of HVAC system to Owner' personnel; if during any demonstration, the system fails to perform in accordance with the information included in the O&M manual, stop demonstration, repair or adjust, and repeat demonstration. Demonstrations may be combined with training sessions if appropriate.
- C. These demonstrations are in addition to, and not a substitute for, Prefunctional Checklists and demonstrations to CxP during Functional Testing.
- D. Provide classroom and hands-on training of Owner's designated personnel on operation and maintenance of the HVAC system, control system, and all equipment items indicated to be commissioned. Provide the following minimum durations of training:
- E. TAB Review: Instruct Owner's personnel for minimum ____ hours, after completion of TAB, on the following:

1. Review final TAB report, explaining the layout and meanings of each data type.
 2. Discuss any outstanding deficient items in control, ducting or design that may affect the proper delivery of air or water.
 3. Identify and discuss any terminal units, duct runs, diffusers, coils, fans and pumps that are close to or are not meeting their design capacity.
 4. Discuss any temporary settings and steps to finalize them for any areas that are not finished.
 5. Other salient information that may be useful for facility operations, relative to TAB.
- F. HVAC Control System Training: Perform training in at least three phases:
1. Phase 1 - Basic Control System: Provide minimum of ____ hours of actual training on the control system itself. Upon completion of training, each attendee, using appropriate documentation, should be able to perform elementary operations and describe general hardware architecture and functionality of the system.
 - a. This training may be held on-site or at the manufacturer's facility.
 - b. If held off-site, the training may occur prior to final completion of the system installation.
 - c. For off-site training, Contractor shall pay expenses of up to two attendees.
 2. Phase 2 - Integrating with HVAC Systems: Provide minimum of ____ hours of on-site, hands-on training after completion of Functional Testing. Include instruction on:
 - a. The specific hardware configuration of installed systems in this facility and specific instruction for operating the installed system, including interfaces with other systems, if any.
 - b. Security levels, alarms, system start-up, shut-down, power outage and restart routines, changing setpoints and alarms and other typical changed parameters, overrides, freeze protection, manual operation of equipment, optional control strategies that can be considered, energy savings strategies and set points that if changed will adversely affect energy consumption, energy accounting, procedures for obtaining vendor assistance, etc.
 - c. Trend logging and monitoring features (values, change of state, totalization, etc.), including setting up, executing, downloading, viewing both tabular and graphically and printing trends; provide practice in setting up trend logging and monitoring during training session.
 - d. Every display screen, allowing time for questions.
 - e. Point database entry and modifications.
 3. Phase 3 - Post-Occupancy: Six months after occupancy conduct minimum of ____ hours of training. Tailor training session to questions and topics solicited beforehand from Owner. Also be prepared to address topics brought up and answer questions concerning operation of the system.
- G. Provide the services of manufacturer representatives to assist instructors where necessary.

- H. Provide the services of the HVAC controls instructor at other training sessions, when requested, to discuss the interaction of the controls system as it relates to the equipment being discussed.

END OF SECTION

SECTION 23 09 13 - INSTRUMENTATION AND CONTROL DEVICES FOR HVAC

PART 1 GENERAL

1.1 SECTION INCLUDES

- A. Control panels.
- B. Control Valves:
 - 1. Ball valves and actuators.
 - 2. Butterfly pattern.
 - 3. Electronic operators.
- C. Dampers.
- D. Damper Operators:
 - 1. Electric operators.
- E. Input/Output Sensors:
 - 1. Temperature sensors.
 - 2. Humidity sensors.
 - 3. Static pressure (air pressure) sensors.
 - 4. Equipment operation (current) sensors.
 - 5. Damper position indicators.
 - 6. Carbon dioxide sensors.
- F. Thermostats:
 - 1. Electric room thermostats.
 - 2. Outdoor reset thermostats.
 - 3. Immersion thermostats.
 - 4. Airstream thermostats.
- G. Time clocks.
- H. Transmitters:
 - 1. Pressure transmitters.
 - 2. Air pressure transmitters.
 - 3. Temperature transmitters.
- I. Flow Sensors:
 - 1. Venturi tubes.
 - 2. Airflow measurement array (AFMA).

3. Annular pitot tubes.
4. Ultrasonic flow meters.
5. Positive displacement flow meters.
6. Flow switches.

1.2 RELATED REQUIREMENTS

- A. Section 26 05 83 - Wiring Connections: Electrical characteristics and wiring connections.
- B. Section 26 27 26 - Wiring Devices: Elevation of exposed components.

1.3 REFERENCE STANDARDS

- A. AMCA 500-D - Laboratory Methods of Testing Dampers for Rating; 2018.
- B. ANSI/FCI 70-2 - Control Valve Seat Leakage; 2021.
- C. NEMA EN 10250 - Enclosures for Electrical Equipment (1000 Volts Maximum); 2024.
- D. NEMA DC 3 - Residential Controls - Electrical Wall-Mounted Room Thermostats; 2013.

1.4 ADMINISTRATIVE REQUIREMENTS

- A. Preinstallation Meeting: Conduct a preinstallation meeting one week before starting work of this section; require attendance by all affected installers.

1.5 SUBMITTALS

- A. See Section 01 30 00 - Administrative Requirements for submittal procedures.
- B. Product Data: Provide description and engineering data for each control system component. Include sizing as requested. Provide data for each system component and software module.
- C. Warranty: Submit manufacturer's warranty and ensure forms have been filled out in Owner's name and registered with manufacturer.

1.6 QUALITY ASSURANCE

- A. Designer Qualifications: Design system under direct supervision of a Professional Engineer experienced in design of this work and licensed in the State in which the Project is located.
- B. Manufacturer Qualifications: Company specializing in manufacturing the Products specified in this section with minimum three years documented experience.
- C. Installer Qualifications: Company specializing in performing the work of this section with minimum 3 years experience approved by manufacturer.
- D. Products Requiring Electrical Connection: Listed and classified by Underwriters Laboratories Inc., as suitable for the purpose specified and indicated.

1.7 WARRANTY

- A. See Section 01 78 00 - Closeout Submittals, for additional warranty requirements.
- B. Correct defective work within a five year period after Substantial Completion.

PART 2 PRODUCTS

2.1 EQUIPMENT - GENERAL

- A. Products Requiring Electrical Connection: Listed and classified by Underwriters Laboratories Inc., as suitable for the purpose specified and indicated.

2.2 CONTROL PANELS

- A. Unitized cabinet type for each system under automatic control with relays and controls mounted in cabinet and temperature indicators, pressure gauges, pilot lights, push buttons and switches flush on cabinet panel face.
- B. NEMA EN 10250, general purpose utility enclosures with enameled finished face panel.
- C. Provide common keying for all panels.

2.3 CONTROL VALVES

- A. Ball Valves and Actuators:
 - 1. Service: Use for hot water.
 - 2. Flow Characteristic: Include 2-way and 3-way diverting operation configured to fail normally closed (NC).
 - 3. Replacements in Kind: Provide pressure-independent type.
 - 4. Rangeability: 500 to 1.
 - 5. ANSI Rating: Class 150.
 - 6. Leakage: Class IV (0.1 percent of rated capacity) per ANSI/FCI 70-2.
 - 7. Body Size:
 - a. Under 2-1/2 inches:
 - 1) Connection: NPT.
 - 2) Materials:
 - (a) Body: Brass.
 - (b) Flanges: Ductile iron.
 - (c) Ball: 300 series stainless steel.
 - (d) Stem: 300 series stainless steel.
 - (e) Seat: Graphite-reinforced PTFE with EPDM O-Ring backing.
 - (f) Stem Seal: EPDM O-Rings.
 - (g) Flow Control Disk: Thermoplastic synthetic-resin.
 - b. 2-1/2 inches and Above:
 - 1) Connection Type: Flanged.
 - 2) Materials:

- (a) Body: Brass.
 - (b) Flanges: Ductile iron.
 - (c) Ball: 300 series stainless steel.
 - (d) Stem: 300 series stainless steel.
 - (e) Seat: Graphite-reinforced PTFE with EPDM O-Ring backing.
 - (f) Stem Seal: EPDM O-Rings.
 - (g) Flow Control Disk: Thermoplastic synthetic-resin.
 - c. Service Temperature:
 - 1) Fluid Side: 0 to 284 degrees F liquid or 25 psig steam.
 - 2) Ambient Side: From minus 4 to 122 degrees F.
- 8. Actuator Requirements:
 - a. Assembly: Factory-mounted.
 - b. Input: 4 to 20 mA configured for proportional control.
 - c. Accessories: Provide with valve position indicator and manual override.
- B. Butterfly Pattern:
 - 1. Manufacturers:
 - a. Belimo Aircontols (USA), Inc
 - b. Johnson Controls International, PLC
 - c. Schneider Electric:
 - d. Substitutions: See Section 01 60 00 - Product Requirements.
 - 2. Iron body, stainless steel disc, resilient replaceable seat for service to 250 degrees F wafer or lug ends, extended neck.
 - 3. Hydronic Systems:
 - a. Rate for service pressure of 125 psig at 250 degrees F.
 - b. Size for 1 psig maximum pressure drop at design flow rate.
- C. Electronic Operators:
 - 1. Manufacturers:
 - a. Belimo Aircontrols (USA), Inc
 - b. Johnson Controls International, PLC
 - c. Schneider Electric
 - d. Substitutions: See Section 01 60 00 - Product Requirements.

2.4 DAMPERS

- A. Performance: Test in accordance with AMCA 500-D.

- B. Frames: Galvanized steel, welded or riveted with corner reinforcement, minimum 12 gauge, 0.1046 inch.
- C. Blades: Galvanized steel, maximum blade size 8 inches wide, 48 inches long, minimum 22 gauge, 0.0299 inch, attached to minimum 1/2 inch shafts with set screws.
- D. Blade Seals: Synthetic elastomeric, inflatable, mechanically attached, field replaceable.
- E. Jamb Seals: Spring stainless steel.
- F. Shaft Bearings: Oil impregnated sintered bronze.
- G. Linkage Bearings: Oil impregnated sintered bronze.
- H. Leakage: Less than one percent based on approach velocity of 2000 ft per min and 4 inches wg.
- I. Maximum Pressure Differential: 6 inches wg.
- J. Temperature Limits: Minus 40 to 200 degrees F.

2.5 DAMPER OPERATORS

- A. General: Provide smooth proportional control with sufficient power for air velocities 20 percent greater than maximum design velocity and to provide tight seal against maximum system pressures. Provide spring return for two position control and for fail safe operation.
 - 1. Provide sufficient number of operators to achieve unrestricted movement throughout damper range.
 - 2. Provide one operator for maximum 36 sq ft damper section.
- B. Electric Operators:
 - 1. Manufacturers:
 - a. Belimo Aircontrols (USA), Inc
 - b. Johnson Controls Internationalm PLC
 - c. Schneider Electric
 - 2. Spring return, adjustable stroke motor having oil immersed gear train, with auxiliary end switch.
- C. Inlet Vane Operators:

2.6 INPUT/OUTPUT SENSORS

- A. Temperature Sensors:
 - 1. Use RTD type temperature sensing elements with characteristics resistant to moisture, vibration, and other conditions consistent with the application without affecting accuracy and life expectancy.
 - 2. Construct RTD of nickel or platinum with base resistance of 1000 ohms at 70 degrees F.
 - 3. 100 ohm platinum RTD is acceptable if used with project DDC controllers.
 - 4. Temperature Sensing Device: Compatible with project DDC controllers.

5. Performance Characteristics:
 - a. RTD:
 - 1) Room Sensor Accuracy: Plus/minus 0.50 degrees F minimum.
 - 2) Duct Averaging Accuracy: Plus/minus 0.50 degrees F minimum.
 - 3) Chilled Water Accuracy: Plus/minus 0.50 degrees F minimum.
 - 4) All Other Accuracy: Plus/minus 0.75 degrees F minimum.
 - 5) Range: Minus 40 degrees F through 220 degrees F minimum.
 - b. Sensing Range:
 - 1) Provide limited range sensors if required to sense the range expected for a respective point.
 - 2) Use RTD type sensors for extended ranges beyond minus 30 degrees F to 230 degrees F.
 - 3) Use temperature transmitters in conjunction with RTD's when RTD's are incompatible with DDC controller direct temperature input.
 - c. Wire Resistance:
 - 1) Use appropriate wire size to limit temperature offset due to wire resistance to 1.0 degree F or use temperature transmitter when offset is greater than 1.0 degree F due to wire resistance.
 - 2) Compensate for wire resistance in software input definition when feature is available in the DDC controller.
 - d. Outside Air Sensors: Watertight inlet fitting shielded from direct rays of the sun.
 - e. Room Temperature Sensors:
 - 1) Construct for surface or wall box mounting.
 - 2) Provide the following:
 - (a) Setpoint reset slide switch with an adjustable temperature range.
 - (b) Individual heating/cooling setpoint slide switches.
 - (c) Momentary override request push button for activation of after-hours operation.
 - (d) Analog thermometer.
 - f. Temperature Averaging Elements:
 - 1) Use on duct sensors for ductwork 10 sq ft or larger.
 - 2) Use averaging elements where prone to stratification with sensor length 8 ft.
 - 3) Provide for all mixed air and heating coil discharge sensors regardless of duct size.
 - g. Insertion Elements:

- 1) Use in ducts not affected by temperature stratification or smaller than 11 sq inches.
 - 2) Provide dry type, insertion elements for liquids, installed in immersion wells, with minimum insertion length of 2.5 inches.
- B. Equipment Operation (Current) Sensors:
1. Status Inputs for Fans: Differential pressure switch with adjustable range of 0 to 5 inches wg.
 2. Status Inputs for Pumps: Differential pressure switch piped across pump with adjustable pressure differential range of 8 to 60 psi.
 3. Status Inputs for Electric Motors: Current sensing relay with current transformers, adjustable and set to 175 percent of rated motor current.
- C. Damper Position Indicators: Potentiometer mounted in enclosure with adjustable crank arm assembly connected to damper to transmit 0 to 100 percent damper travel.

2.7 THERMOSTATS

- A. Electric Room Thermostats:
1. Type: NEMA DC 3, 24 volts, with setback/setup temperature control.
 2. Service: Cooling only.
 3. Covers: Locking with set point adjustment, with thermometer.

2.8 TRANSMITTERS

- A. Temperature Transmitters:
1. One pipe, directly proportional output signal to measured variable, linearity within plus or minus 1/2 percent of range for 200 degrees F span and plus or minus 1 percent for 50 degrees F span, with 50 degrees F. temperature range, compensated bulb, averaging capillary, or rod and tube operation on 20 psig input pressure and 3 to 15 psig output.

2.9 FLOW SENSORS

- A. Venturi Tubes:
1. Fabricate the venturi tube from cast iron with an accuracy of plus/minus 1 percent of full flow.
 2. Line the throat section with austenitic stainless steel.
 3. Thermal Expansion Characteristics of the Lining: Same as that of the throat casting material.
 4. Machine the surface of the throat to plus/minus 50 micro-inches including the short curvature leading from the converging entrance section into the throat.
- B. Airflow Measurement Array (AFMA):
1. Airflow Straighteners:

- a. Provide AFMA's with an airflow straightener if required by the AFMA manufacturer's published installation instructions.
 - b. In the absence of published documentation, provide airflow straighteners if there is any duct obstruction within 5 duct diameters upstream of the AFMA.
 - c. Straightener: Contained inside a flanged sheet metal casing, with the AFMA located as specified according to the published recommendations of the AFMA manufacturer.
 - d. Construction to consist of 0.125 inch aluminum honeycomb with the straightener depth not less than 1.5 inches.
2. Airflow Resistance:
- a. Resistance to Airflow Through the AFMA and the Airflow Straightener: Not to exceed 0.085 inches at an airflow velocity of 2000 fpm.
 - b. AFMA Construction: Suitable for operation at air flows of up to 5000 fpm over a temperature range of 40 degrees F to 120 degrees F.
3. Pitot Tube:
- a. Furnish each pitot tube AFMA with an array of velocity sensing elements.
 - b. Velocity Sensing Elements: Multiple pitot tube type with averaging manifolds.
 - c. Distribute the sensing elements across the duct section in the pattern and quantity specified or as recommended by the installation instructions of the AMFA manufacturer.
 - 1) Pitot Tube AFMA's in Air Flows Over 600 fpm: Accuracy of plus/minus 5 percent over a range of 500 fpm to 2500 fpm.
 - 2) Pitot Tube AFMA's in Air Flows Under 600 fpm: Accuracy of plus/minus 5 percent over a range of 125 fpm to 2500 fpm.
4. Electronic:
- a. Each electronic AFMA to consist of an array of velocity sensing elements of the resistance temperature detector (RTD) or thermistor type.
 - b. Sensing Elements: Distributed across the duct cross section in the quantity and pattern specified or recommended by the published application data of the manufacturer.
 - c. Electronic AFMA's: Accuracy of plus/minus 5 percent over a range of 125 fpm to 5,000 fpm and temperature compensated output over a range of 32 degrees F to 212 degrees F.
 - d. Fan Inlet Measurement Devices: Refer to drawings and/or equipment schedules.
- C. Annular Pitot Tubes:
1. Fabricate the annular pitot tube from austenitic stainless steel with an accuracy of plus/minus 2 percent of full flow and a repeatability of plus/minus 0.50 percent of measured value.

2. Unit to have at least one static port with no less than four total head pressure ports with an averaging manifold.
- D. Positive Displacement Flow Meters:
1. Provide a direct reading, gerotor, nutating disc, or vane type displacement device rated for liquid service as indicated.
 2. A counter must be mounted on top of the meter and consist of a non-resettable mechanical totalizer for local reading, and a pulse transmitter for remote reading.
 3. Provide totalizer with six digit register to indicate the volume passed through the meter in gallons, and a sweep-hand dial with indication down to 0.25 gallons.
 4. Equip the pulse transmitter with a hermetically sealed reed switch, activated by magnets fixed on gears of the counter.
 5. Output Accuracy: Plus/minus 2 percent of the flow range.
 6. Maximum Pressure Drop: 5 psi.
- E. Flow Switches:
1. Repetitive Accuracy: Plus/minus 10 percent of actual flow setting.
 2. Switch Actuation: Adjustable over the operating range and sized for the application, such that the setpoint is between 25 and 75 percent of the full range.
 3. Provide Form C snap-action contacts, rated for the application.
 4. Furnish non-flexible paddle with magnetically actuated contacts, rated for service at a pressure greater than the installed conditions.

PART 3 EXECUTION

3.1 EXAMINATION

- A. Verify existing conditions before starting work.
- B. Verify that systems are ready to receive work.
- C. Beginning of installation means installer accepts existing conditions.
- D. Sequence work to ensure installation of components is complementary to installation of similar components in other systems.
- E. Coordinate installation of system components with installation of mechanical systems equipment such as air handling units and air terminal units.
- F. Ensure installation of components is complementary to installation of similar components.
- G. Coordinate installation of system components with installation of mechanical systems equipment such as air handling units and air terminal units.

3.2 INSTALLATION

- A. Install in accordance with manufacturer's instructions.

- B. Check and verify location of thermostats with plans and room details before installation. Locate 48 inches above floor. Align with lighting switches and humidistats. See Section 26 27 26.
- C. Mount outdoor reset thermostats and outdoor sensors indoors, with sensing elements outdoors with sun shield.
- D. Provide separable sockets for liquids and flanges for air bulb elements.
- E. Provide thermostats in aspirating boxes in front entrances.
- F. Provide guards on thermostats in entrances.
- G. Provide mixing dampers of opposed blade construction arranged to mix streams. Provide pilot positioners on mixed air damper motors.
- H. Provide isolation (two position) dampers of parallel blade construction.
- I. Provide pilot positioners on pneumatic damper operators sequenced with other controls.
- J. Install damper motors on outside of duct in warm areas. Do not install motors in locations at outdoor temperatures.
- K. Mount control panels adjacent to associated equipment on vibration free walls or free standing angle iron supports. One cabinet may accommodate more than one system in same equipment room. Provide engraved plastic nameplates for instruments and controls inside cabinet and engraved plastic nameplates on cabinet face.
- L. Install "hand/off/auto" selector switches to override automatic interlock controls when switch is in "hand" position.
- M. Provide conduit and electrical wiring in accordance with Section 26 05 83. Electrical material and installation shall be in accordance with appropriate requirements of Division 26.

3.3 MAINTENANCE

- A. Provide service and maintenance of control system for one year from Date of Substantial Completion.
- B. Provide complete service of controls systems, including call backs, and submit written report of each service call.
- C. In addition to normal service calls, make minimum of 4 complete normal inspections of approximately 4 hours duration to inspect, calibrate, and adjust controls.

END OF SECTION

SECTION 23 11 23 - FACILITY NATURAL-GAS PIPING

PART 1 GENERAL

1.1 SECTION INCLUDES

- A. Pipe, pipe fittings, valves, and connections for natural gas piping systems.

1.2 RELATED REQUIREMENTS

- A. Section 22 07 19 - Plumbing Piping Insulation.
- B. Section 23 05 53 - Identification for HVAC Piping and Equipment.

1.3 SUBMITTALS

- A. See Section 01 30 00 - Administrative Requirements, for submittal procedures.
- B. Product Data: Provide data on pipe materials, pipe fittings, valves, and accessories. Provide manufacturers catalog information. Indicate valve data and ratings.

1.4 QUALITY ASSURANCE

- A. Perform work in accordance with applicable codes.
- B. Valves: Manufacturer's name and pressure rating marked on valve body.
- C. Welding Materials and Procedures: Comply with ASME BPVC-IX and applicable state labor regulations.
- D. Welder Qualifications: Certified in accordance with ASME BPVC-IX.
- E. Identify pipe with marking including size, ASTM material classification, and ASTM specification.

1.5 DELIVERY, STORAGE, AND HANDLING

- A. Accept valves on site in shipping containers with labeling in place. Inspect for damage.
- B. Provide temporary protective coating on cast iron and steel valves.
- C. Provide temporary end caps and closures on piping and fittings. Maintain in place until installation.
- D. Protect piping systems from entry of foreign materials by temporary covers, completing sections of the work, and isolating parts of completed system.

PART 2 PRODUCTS

2.1 NATURAL GAS PIPING, BURIED WITHIN 5 FEET OF BUILDING

- A. Steel Pipe: ASTM A53/A53M, Schedule 40 black.
 - 1. Fittings: ASTM A234/A234M, wrought steel welding type.
 - 2. Joints: ANSI Z223.1, welded.

3. Jacket: AWWA C105/A21.5 polyethylene jacket or double layer, half-lapped 10 mil polyethylene tape.

2.2 NATURAL GAS PIPING, ABOVE GRADE

- A. Steel Pipe: ASTM A53/A53M, Schedule 40 black.
 1. Fittings: ASME B16.3, malleable iron, or ASTM A234/A234M, wrought steel welding type.
 2. Joints: Threaded or welded to ASME B31.1.
 3. Mechanical Press Sealed Fittings: Double pressed type and approved or certified, utilizing EPDM, non toxic synthetic rubber sealing elements.

2.3 FLANGES, UNIONS, AND COUPLINGS

- A. Unions for Pipe Sizes 3 Inches and Under:
 1. Ferrous Pipe: Class 150 malleable iron threaded unions.
- B. Flanges for Pipe Size Over 1 Inch:
 1. Ferrous Pipe: Class 150 malleable iron threaded or forged steel slip-on flanges; preformed neoprene gaskets.

2.4 PLUG VALVES

- A. Construction 2-1/2 Inches and Larger: MSS SP-78, 175 psi CWP, cast iron body and plug, pressure lubricated, Teflon or Buna N packing, flanged ends. Provide lever operator with set screw.

PART 3 EXECUTION

3.1 PREPARATION

- A. Ream pipe and tube ends. Remove burrs. Bevel plain end ferrous pipe.
- B. Remove scale and dirt, on inside and outside, before assembly.
- C. Prepare piping connections to equipment with flanges or unions.

3.2 INSTALLATION

- A. Install in accordance with manufacturer's instructions.
- B. Provide non-conducting dielectric connections wherever jointing dissimilar metals.
- C. Route piping in orderly manner and maintain gradient. Route parallel and perpendicular to walls.
- D. Install piping to maintain headroom, conserve space, and not interfere with use of space.
- E. Group piping whenever practical at common elevations.
- F. Provide clearance in hangers and from structure and other equipment for installation of insulation and access to valves and fittings.

1. Refer to Section 22 07 19.
- G. Prepare exposed, unfinished pipe, fittings, supports, and accessories ready for finish painting.
 1. Painting of interior piping systems and components is specified in Section 09 91 23.
 2. Painting of exterior piping systems and components is specified in Section 09 91 13.
- H. Install valves with stems upright or horizontal, not inverted.
- I. Sleeve pipes passing through partitions, walls and floors.
- J. Pipe Hangers and Supports:
 1. Install in accordance with ASME B31.9.
 2. Support horizontal piping as indicated.
 3. Install hangers to provide minimum 1/2 inch space between finished covering and adjacent work.
 4. Place hangers within 12 inches of each horizontal elbow.
 5. Use hangers with 1-1/2 inch minimum vertical adjustment. Design hangers for pipe movement without disengagement of supported pipe.

3.3 APPLICATION

- A. Install unions downstream of valves and at equipment or apparatus connections.
- B. Provide plug valves in natural gas systems for shut-off service.

END OF SECTION

This page intentionally left blank

SECTION 23 21 13 - HYDRONIC PIPING

PART 1 GENERAL

1.1 SECTION INCLUDES

- A. Hydronic system requirements.
- B. Heating water piping, above grade.
- C. Pipe hangers and supports.
- D. Unions, flanges, mechanical couplings, and dielectric connections.
- E. Valves:

1.2 RELATED REQUIREMENTS

- A. Section 23 05 16 - Expansion Fittings and Loops for HVAC Piping.

1.3 SUBMITTALS

- A. See Section 01 30 00 - Administrative Requirements for submittal procedures.
- B. Product Data:
 - 1. Include data on pipe materials, pipe fittings, valves, and accessories.
 - 2. Indicate valve data and ratings.

PART 2 PRODUCTS

2.1 HYDRONIC SYSTEM REQUIREMENTS

- A. Comply with ASME B31.9 and applicable federal, state, and local regulations.
- B. Piping: Provide piping, fittings, hangers, and supports as required, as indicated, and as follows:
 - 1. Where more than one piping system material is specified, provide joining fittings that are compatible with piping materials and ensure that the integrity of the system is not jeopardized.
 - 2. Use non-conducting dielectric connections whenever jointing dissimilar metals.
 - 3. Grooved mechanical joints may be used in accessible locations only.
 - a. Accessible locations include those exposed on interior of building, in pipe chases, and in mechanical rooms, aboveground outdoors, and as approved by Architect.
 - b. Use rigid joints unless otherwise indicated.
 - 4. Provide pipe hangers and supports in accordance with ASME B31.9 or MSS SP-58 unless indicated otherwise.

- C. Pipe-to-Valve and Pipe-to-Equipment Connections: Use flanges, unions, or grooved couplings to allow disconnection of components for servicing; do not use direct welded, soldered, or threaded connections.
- D. Valves: Provide valves where indicated:
 - 1. Provide drain valves where indicated, and if not indicated, provide at least at main shut-off, low points of piping, bases of vertical risers, and at equipment. Use 3/4 inch gate valves with cap; pipe to nearest floor drain.
 - 2. In heating water systems, butterfly valves may be used interchangeably with gate and globe valves.
 - 3. For shut-off and to isolate parts of systems or vertical risers, use gate, ball, or butterfly valves.
 - 4. For throttling service, use plug cocks. Use non-lubricated plug cocks only when shut-off or isolating valves are also provided.

2.2 HEATING WATER PIPING, ABOVE GRADE

- A. Copper Tube: ASTM B88 (ASTM B88M), Type L (B), drawn, using one of the following joint types:
 - 1. Solder Joints: ASME B16.18 cast brass/bronze or ASME B16.22 solder wrought copper fittings.
 - a. Solder: ASTM B32 lead-free solder, HB alloy (95-5 tin-antimony) or tin and silver.
 - b. Braze: AWS A5.8M/A5.8 BCuP copper/silver alloy.
 - 2. Mechanical Press Sealed Fittings: Double pressed type complying with ASME B16.51, utilizing EPDM, nontoxic synthetic rubber sealing elements.

2.3 UNIONS, FLANGES, MECHANICAL COUPLINGS, AND DIELECTRIC CONNECTIONS

- A. Unions for Pipe of 2 Inches and Less:
- B. Flanges for Pipe 2 Inches and Greater:

PART 3 EXECUTION

3.1 PREPARATION

- A. Ream pipe and tube ends. Remove burrs. Bevel plain end ferrous pipe.
- B. Remove scale and dirt on inside and outside before assembly.
- C. Prepare piping connections to equipment using jointing system specified.
- D. Keep open ends of pipe free from scale and dirt. Protect open ends with temporary plugs or caps.
- E. After completion, fill, clean, and treat systems. See Section 23 25 00 for additional requirements.

3.2 INSTALLATION

- A. Install in accordance with manufacturer's instructions.
- B. Route piping in orderly manner, parallel to building structure, and maintain gradient.
- C. Install piping to conserve building space and to avoid interference with use of space.
- D. Group piping whenever practical at common elevations.
- E. Slope piping and arrange to drain at low points.
- F. Install piping to allow for expansion and contraction without stressing pipe, joints, or connected equipment. See Section 23 05 16.
 - 1. Flexible couplings may be used in header piping to accommodate thermal growth, thermal contraction in lieu of expansion loops.
 - 2. Use flexible couplings in expansion loops.

END OF SECTION

This page intentionally left blank

SECTION 23 21 14 - HYDRONIC SPECIALTIES

PART 1 GENERAL

1.1 SECTION INCLUDES

- A. Air vents.
- B. Strainers.
- C. Balancing valves.
- D. Automatic flow control valves.
- E. Relief valves.

1.2 RELATED REQUIREMENTS

1.3 SUBMITTALS

- A. See Section 01 30 00 - Administrative Requirements for submittal procedures.
- B. Product Data: Provide product data for manufactured products and assemblies required for this project. Include component sizes, rough-in requirements, service sizes, and finishes. Include product description and model.

PART 2 PRODUCTS

2.1 AIR VENTS

- A. Manual Air Vent: Short vertical sections of 2-inch diameter pipe to form air chamber, with 1/8 inch brass needle valve at top of chamber.
- B. Maximum Fluid Pressure: 150 psi.
- C. Maximum Fluid Temperature: 250 degrees F.

2.2 STRAINERS

- A. Size 2 inch and Under:
 - 1. Provide threaded or sweat brass or iron body for up to 175 psi working pressure, Y-pattern strainer with 1/32 inch stainless steel perforated screen.
- B. Size 2-1/2 inch to 4 inch:
 - 1. Provide flanged or grooved iron body for up to 175 psi working pressure, up to 250 degrees F working temperature, Y-pattern strainer with 1/16 inch or 3/64 inch stainless steel perforated screen.

2.3 BALANCING VALVES

- A. Size 2 inch and Smaller:

1. Provide ball or globe style with flow balancing, shut-off capabilities, memory stops, and minimum of two metering ports and female sweat, NPT threaded, press, or soldered connections.
 2. Metal construction materials consist of bronze or brass.
 3. Non-metal construction materials consist of Teflon, EPDM, or engineered resin.
- B. Size 2-1/2 inch and Larger:
1. Provide ball, globe, or butterfly style with flow balancing, shut-off capabilities, memory stops, and minimum of two metering ports and flanged, grooved, or weld-end connections.
 2. Valve body construction materials consist of cast iron, carbon steel, or ductile iron.
 3. Internal components construction materials consist of brass, aluminum bronze, bronze, Teflon, EPDM, NORYL, or engineered resin.

2.4 AUTOMATIC FLOW CONTROL VALVES

- A. Construction:
1. Brass, bronze, or iron body with union on inlet and outlet, temperature and pressure test plug on inlet and outlet with blowdown/backflush drain.
 2. Built-in lug-type outlet butterfly valve with 2-position handle.
- B. Calibration: Control flow within 10 percent of selected rating, over operating pressure range of 10 times minimum pressure required for control, minimum pressure 2 psi.
- C. Control Mechanism: Provide stainless steel or nickel-plated, brass piston or regulator cup, operating against stainless steel helical or wave formed spring or elastomeric diaphragm and polyphenylsulfone orifice plate.

2.5 RELIEF VALVES

- A. Bronze body, teflon seat, stainless steel stem and springs, automatic, direct pressure actuated, capacities ASME certified and labelled.

2.6 PRESSURE INDEPENDENT VALVES

- A. Size 2 inch and Smaller:
1. Provide ball or globe style with flow balancing, flow measurement, and shut-off capabilities, memory stops, minimum of two metering ports and NPT threaded or soldered connections.
 2. Metal construction materials consist of bronze or brass.
 3. Non-metal construction materials consist of Teflon, EPDM, or engineered resin.
- B. Size 2-1/2 inch and Larger:
1. Provide ball, globe, or butterfly style with flow balancing, flow measurement, and shut-off capabilities, memory stops, minimum of two metering ports and flanged, grooved, or weld end connections.

2. Valve body construction materials consist of cast iron, carbon steel, or ductile iron.
3. Internal components construction materials consist of brass, aluminum bronze, bronze, or EPDM.

PART 3 EXECUTION

3.1 INSTALLATION

- A. Install specialties in accordance with manufacturer's instructions.
- B. Provide manual air vents at system high points and as indicated.
- C. For automatic air vents in ceiling spaces or other concealed locations, provide vent tubing to nearest drain.
- D. Provide air separator on suction side of system circulation pump and connect to expansion tank.
- E. Provide relief valves on pressure tanks, low-pressure side of reducing valves, heat exchangers, and expansion tanks.
- F. Select system relief valve capacity so that it is greater than make-up pressure reducing valve capacity. Select equipment relief valve capacity to exceed rating of connected equipment.
- G. Pipe relief valve outlet to nearest floor drain.
- H. Where one line vents several relief valves, make cross-sectional area equal to sum of individual vent areas.

END OF SECTION

This page intentionally left blank

SECTION 23 31 00 - HVAC DUCTS AND CASINGS

PART 1 GENERAL

1.1 SECTION INCLUDES

- A. Metal ductwork.

1.2 RELATED REQUIREMENTS

- A. Section 07 84 00 - Firestopping.
- B. Section 09 91 23 - Interior Painting: Weld priming, paint or coating.
- C. Section 23 01 30.51 - HVAC Air-Distribution System Cleaning: Cleaning ducts after completion of installation.
- D. Section 23 05 93 - Testing, Adjusting, and Balancing for HVAC.
- E. Section 23 07 13 - Duct Insulation: External insulation and duct liner.
- F. Section 23 33 00 - Air Duct Accessories.
- G. Section 23 37 00 - Air Outlets and Inlets.

1.3 REFERENCE STANDARDS

- A. ASTM A653/A653M - Standard Specification for Steel Sheet, Zinc-Coated (Galvanized) or Zinc-Iron Alloy-Coated (Galvannealed) by the Hot-Dip Process; 2023.
- B. NFPA 90A - Standard for the Installation of Air-Conditioning and Ventilating Systems; 2024.
- C. SMACNA (DCS) - HVAC Duct Construction Standards Metal and Flexible; 2020.

1.4 SUBMITTALS

- A. See Section 01 30 00 - Administrative Requirements, for submittal procedures.
- B. Product Data: Provide data for duct materials.

1.5 FIELD CONDITIONS

- A. Do not install duct sealants when temperatures are less than those recommended by sealant manufacturers.
- B. Maintain temperatures within acceptable range during and after installation of duct sealants.

PART 2 PRODUCTS

2.1 DUCT ASSEMBLIES

- A. Regulatory Requirements: Construct ductwork to comply with NFPA 90A standards.
- B. Ducts: Galvanized steel, unless otherwise indicated.

- C. Low Pressure Supply (System with Cooling Coils): 1/2 inch w.g. pressure class, galvanized steel.
- D. Return and Relief: 1/2 inch w.g. pressure class, galvanized steel.
- E. General Exhaust: 1/2 inch w.g. pressure class, galvanized steel.

2.2 MATERIALS

- A. Galvanized Steel for Ducts: Hot-dipped galvanized steel sheet, ASTM A653/A653M FS Type B, with G60/Z180 coating.

2.3 DUCTWORK FABRICATION

- A. Fabricate and support in accordance with SMACNA (DCS) and as indicated.
- B. Provide duct material, gages, reinforcing, and sealing for operating pressures indicated.
- C. Construct T's, bends, and elbows with radius of not less than 1-1/2 times width of duct on centerline. Where not possible and where rectangular elbows must be used, provide air foil turning vanes of perforated metal with glass fiber insulation.
- D. Provide turning vanes of perforated metal with glass fiber insulation when acoustical lining is indicated.
- E. Increase duct sizes gradually, not exceeding 15 degrees divergence wherever possible; maximum 30 degrees divergence upstream of equipment and 45 degrees convergence downstream.
- F. Fabricate continuously welded round and oval duct fittings in accordance with SMACNA (DCS).
- G. Where ducts are connected to exterior wall louvers and duct outlet is smaller than louver frame, provide blank-out panels sealing louver area around duct. Use same material as duct, painted black on exterior side; seal to louver frame and duct.

2.4 MANUFACTURED DUCTWORK AND FITTINGS

- A. Double Wall Insulated Round Ducts: Round spiral lockseam duct with galvanized steel outer wall, perforated galvanized steel inner wall; fitting with solid inner wall.
 - 1. Manufacture in accordance with SMACNA (DCS).
 - 2. Insulation:
 - a. Thickness: 1 inch.
 - b. Material: Air.
- B. Spiral Ducts: Round spiral lockseam duct with galvanized steel outer wall.
 - 1. Manufacture in accordance with SMACNA (DCS).
- C. Round Ducts: Round lockseam duct with galvanized steel outer wall.
 - 1. Manufacture in accordance with SMACNA (DCS).
- D. Flexible Ducts: Black polymer film supported by helically wound spring steel wire.
 - 1. Pressure Rating: 4 inches WG positive and 0.5 inches WG negative.

2. Maximum Velocity: 4000 fpm.
3. Temperature Range: Minus 20 degrees F to 175 degrees F.

PART 3 EXECUTION

3.1 INSTALLATION

- A. Install, support, and seal ducts in accordance with SMACNA (DCS).
- B. Install in accordance with manufacturer's instructions.
- C. During construction provide temporary closures of metal or taped polyethylene on open ductwork to prevent construction dust from entering ductwork system.
- D. Flexible Ducts: Connect to metal ducts with adhesive.
- E. Duct sizes indicated are inside clear dimensions. For lined ducts, maintain sizes inside lining.
- F. Locate ducts with sufficient space around equipment to allow normal operating and maintenance activities.
- G. Use crimp joints with or without bead for joining round duct sizes 8 inch and smaller with crimp in direction of air flow.
- H. Connect terminal units to supply ducts directly or with one foot maximum length of flexible duct. Do not use flexible duct to change direction.
- I. Connect diffusers or light troffer boots to low pressure ducts directly or with 5 feet maximum length of flexible duct held in place with strap or clamp.
- J. At exterior wall louvers, seal duct to louver frame and install blank-out panels.

END OF SECTION

This page intentionally left blank

SECTION 23 33 00 - AIR DUCT ACCESSORIES

PART 1 GENERAL

1.1 SECTION INCLUDES

- A. Backdraft dampers - metal.
- B. Duct access doors.
- C. Duct test holes.
- D. Flexible duct connectors.
- E. Volume control dampers.

1.2 RELATED REQUIREMENTS

- A. Section 23 31 00 - HVAC Ducts and Casings.

1.3 REFERENCE STANDARDS

- A. NFPA 90A - Standard for the Installation of Air-Conditioning and Ventilating Systems; 2024.
- B. SMACNA (DCS) - HVAC Duct Construction Standards Metal and Flexible; 2020.

1.4 SUBMITTALS

- A. See Section 01 30 00 - Administrative Requirements, for submittal procedures.
- B. Product Data: Provide for shop fabricated assemblies including volume control dampers. Include electrical characteristics and connection requirements.

1.5 DELIVERY, STORAGE, AND HANDLING

- A. Protect dampers from damage to operating linkages and blades.

PART 2 PRODUCTS

2.1 BACKDRAFT DAMPERS - METAL

- A. Gravity Backdraft Dampers, Size 18 by 18 inches or Smaller, Furnished with Air Moving Equipment: Air moving equipment manufacturer's standard construction.

2.2 DUCT ACCESS DOORS

- A. Fabrication: Rigid and close-fitting of galvanized steel with sealing gaskets and quick fastening locking devices. For insulated ducts, install minimum 1 inch thick insulation with sheet metal cover.
 - 1. Less Than 12 inches Square: Secure with sash locks.
 - 2. Up to 18 inches Square: Provide two hinges and two sash locks.

3. Up to 24 by 48 inches: Three hinges and two compression latches with outside and inside handles.

2.3 DUCT TEST HOLES

- A. Temporary Test Holes: Cut or drill in ducts as required. Cap with neat patches, neoprene plugs, threaded plugs, or threaded or twist-on metal caps.
- B. Permanent Test Holes: Factory fabricated, air tight flanged fittings with screw cap. Provide extended neck fittings to clear insulation.

2.4 FLEXIBLE DUCT CONNECTORS

- A. Fabricate in accordance with SMACNA (DCS) and as indicated.
- B. Flexible Duct Connections: Fabric crimped into metal edging strip.
 1. Fabric: UL listed fire-retardant neoprene coated woven glass fiber fabric to NFPA 90A, minimum density 30 oz per sq yd.
 - a. Net Fabric Width: Approximately 2 inches wide.
- C. Leaded Vinyl Sheet: Minimum 0.55 inch thick, 0.87 lbs per sq ft, 10 dB attenuation in 10 to 10,000 Hz range.
- D. Maximum Installed Length: 14 inch.

2.5 VOLUME CONTROL DAMPERS

- A. Fabricate in accordance with SMACNA (DCS) and as indicated.
- B. Splitter Dampers:
 1. Material: Same gage as duct to 24 inches size in either direction, and two gages heavier for sizes over 24 inches.
 2. Blade: Fabricate of single thickness sheet metal to streamline shape, secured with continuous hinge or rod.
- C. Single Blade Dampers:
 1. Fabricate for duct sizes up to 6 by 30 inch.
 2. Blade: 24 gage, 0.0239 inch, minimum.
- D. Multi-Blade Damper: Fabricate of opposed blade pattern with maximum blade sizes 8 by 72 inch. Assemble center and edge crimped blades in prime coated or galvanized channel frame with suitable hardware.
 1. Blade: 18 gage, 0.0478 inch, minimum.

PART 3 EXECUTION

3.1 INSTALLATION

- A. Install accessories in accordance with manufacturer's instructions, NFPA 90A, and follow SMACNA (DCS). Refer to Section 23 31 00 for duct construction and pressure class.

- B. Provide backdraft dampers on exhaust fans or exhaust ducts nearest to outside and where indicated.
- C. Provide duct test holes where indicated and required for testing and balancing purposes.
- D. At fans and motorized equipment associated with ducts, provide flexible duct connections immediately adjacent to the equipment.
- E. At equipment supported by vibration isolators, provide flexible duct connections immediately adjacent to the equipment.
- F. Use splitter dampers only where indicated.
- G. Provide balancing dampers on duct take-off to diffusers, grilles, and registers, regardless of whether dampers are specified as part of the diffuser, grille, or register assembly.

END OF SECTION

This page intentionally left blank

SECTION 23 36 00 - AIR TERMINAL UNITS

PART 1 GENERAL

1.1 SECTION INCLUDES

- A. Single-duct terminal units.
 - 1. Variable-volume units.

1.2 RELATED REQUIREMENTS

- A. Section 23 31 00 - HVAC Ducts and Casings.
- B. Section 23 33 00 - Air Duct Accessories.
- C. Section 23 37 00 - Air Outlets and Inlets.

1.3 REFERENCE STANDARDS

- A. AHRI 410 - Forced-Circulation Air-Cooling and Air-Heating Coils; 2001, with Addenda (2011).
- B. AHRI 880 (I-P) - Performance Rating of Air Terminals; 2017 (Reaffirmed 2023).
- C. ASTM A492 - Standard Specification for Stainless Steel Rope Wire; 1995 (Reapproved 2019).
- D. ASTM A603 - Standard Specification for Metallic-Coated Steel Structural Wire Rope; 2019.
- E. ASTM C1071 - Standard Specification for Fibrous Glass Duct Lining Insulation (Thermal and Sound Absorbing Material); 2019.
- F. ASTM E488/E488M - Standard Test Methods for Strength of Anchors in Concrete Elements; 2022.
- G. NFPA 70 - National Electrical Code; Most Recent Edition Adopted by Authority Having Jurisdiction, Including All Applicable Amendments and Supplements.
- H. NFPA 90A - Standard for the Installation of Air-Conditioning and Ventilating Systems; 2024.
- I. SMACNA (SRM) - Seismic Restraint Manual Guidelines for Mechanical Systems; 2024.

1.4 SUBMITTALS

- A. See Section 01 30 00 - Administrative Requirements for submittal procedures.
- B. Product Data: Provide data indicating configuration, general assembly, and materials used in fabrication. Include catalog performance ratings that indicate airflow, static pressure, and NC designation. Include electrical characteristics and connection requirements.

1.5 WARRANTY

- A. See Section 01 78 00 - Closeout Submittals for additional warranty requirements.
- B. Provide five year manufacturer warranty for air terminal units.

PART 2 PRODUCTS

2.1 SINGLE-DUCT, VARIABLE-VOLUME UNITS

A. General:

1. Factory-assembled, AHRI 880 (I-P) rated and bearing the AHRI seal, air volume control terminal with damper assembly, flow sensor, externally mounted volume controller, duct collars, and all required features.
2. Control box bearing identification, including but not necessarily limited to nominal cfm, maximum and minimum factory-set airflow limits, coil type and coil (right or left hand) connection, where applicable.

B. Unit Casing:

1. Minimum 22 gauge, 0.0299 inch galvanized steel.
2. Air Inlet Collar: Provide round or rectangular, suitable for standard flexible duct sizes.
3. Unit Discharge: Rectangular, with slip-and-drive connections.
4. Acceptable Liners:
 - a. 1/2 inch thick, coated, fibrous-glass complying with ASTM C1071.
 - 1) Secure with adhesive.
 - 2) Coat edges exposed to airstream with NFPA 90A approved sealant.
 - 3) Cover liner with non-porous foil.
 - b. Liner not to contain pentabrominated diphenyl ether (CAS #32534-81-9) or octabrominated diphenyl ether.

C. Damper Assembly:

1. Heavy-gauge, galvanized steel, or extruded aluminum construction with solid steel, nickel-plated shaft pivoting on HDPE, self-lubricating bearings.
2. Provide integral position indicator or alternative method for indicating damper position over full range of 90 degrees.
3. Incorporate low leak damper blades for tight airflow shutoff.

D. Hot Water Heating Coil:

1. Coil Casing: Minimum 22 gauge, 0.0299 inch galvanized steel, factory-installed on terminal discharge with rectangular outlet, duct connection type.
2. Coil Fins: Aluminum or aluminum plated fins, mechanically-bonded to seamless copper tubes.
3. Coil leak tested to minimum 350 psig.
4. Base performance data on tests run in accordance with AHRI 410 and units to bear AHRI 410 label.

E. Controls:

1. DDC (Direct-Digital Controls):

- a. Include a factory-installed, unit-mounted, direct-digital controller.
 - b. Bi-directional Damper Actuator: 24 volt, powered closed, spring return open.
 - c. Microprocessor-Based Controller: Air volume controller, pressure-independent with electronic airflow transducers, factory-calibrated maximum and minimum CFMs.
 - 1) Occupied and unoccupied operating mode.
 - 2) Remote reset of temperature or CFM set points.
 - 3) Proportional, plus integral control of room temperature.
 - 4) Monitoring and adjusting with portable terminal.
 - 5) Time-proportional reheat coil control.
 - d. Room Sensor:
 - 1) Compatible with temperature controls specified.
 - 2) Wall-mounted, system powered, with temperature set-point adjustment including connection access for portable operator terminal.
2. Airflow Sensor: Differential pressure airflow device measuring total, static, and wake pressures.
 - a. Signal accuracy: Plus/minus five percent throughout terminal operating range.

PART 3 EXECUTION

3.1 EXAMINATION

- A. Verify that conditions are suitable for installation.
- B. Verify that field measurements are as indicated on drawings.

3.2 INSTALLATION

- A. Install in accordance with manufacturer's instructions.
- B. Install the inlets of air terminal units and air flow sensors a minimum of four duct diameters from elbows, transitions, and duct takeoffs.
- C. See drawings for the size(s) and duct location(s) of the air terminal units.
- D. Provide ceiling access doors or locate units above easily removable ceiling components.
- E. Support units individually from structure with wire rope complying with ASTM A492 and ASTM A603 in accordance with SMACNA (SRM). See Section 23 0548.
- F. Embed anchors in concrete in accordance with ASTM E488/E488M.
- G. Do not support from ductwork.
- H. Connect to ductwork in accordance with Section 23 31 00.
- I. Provide minimum of 5 ft of 1 inch thick lined ductwork downstream of units.
- J. Verify that electric power is available and of the correct characteristics.

3.3 ADJUSTING

- A. Reset volume with damper operator attached to assembly allowing flow range modulation from 100 percent of design flow to zero percent full flow. Set units with heating coils for minimum 30 percent full flow. See schedule on for minimums.

3.4 FIELD QUALITY CONTROL

- A. See Section 01 40 00 - Quality Requirements for additional requirements.
- B. Provide manufacturer's field representative to test, inspect, instruct, and observe field-assembled components and equipment installation, including connections and to assist in field testing. Report results in writing.
 - 1. Operational Test:
 - a. After electrical circuitry has been energized, start units to confirm proper motor rotation and unit operation.
 - b. Test and adjust controls and safeties.
 - c. Replace damaged and malfunctioning controls and other equipment.
 - d. Remove and replace malfunctioning units and retest as specified above.

3.5 CLEANING

- A. See Section 01 74 19 - Construction Waste Management and Disposal for additional requirements.
- B. Vacuum clean coils and inside of units.
- C. Install new filters.

END OF SECTION

SECTION 23 37 00 - AIR OUTLETS AND INLETS

PART 1 GENERAL

1.1 SECTION INCLUDES

- A. Diffusers:
 - 1. Rectangular ceiling diffusers.
- B. Registers/grilles:
 - 1. Ceiling-mounted, exhaust and return register/grilles.
 - 2. Ceiling-mounted, linear exhaust and return register/grilles.
 - 3. Ceiling-mounted, supply register/grilles.
 - 4. Wall-mounted, supply register/grilles.
 - 5. Wall-mounted, linear register/grilles.
- C. Duct-mounted supply and return registers/louvers.

1.2 REFERENCE STANDARDS

- A. SMACNA (ASMM) - Architectural Sheet Metal Manual; 2012.

1.3 SUBMITTALS

- A. See Section 01 30 00 - Administrative Requirements for submittal procedures.
- B. Product Data: Provide data for equipment required for this project. Review outlets and inlets as to size, finish, and type of mounting prior to submission. Submit schedule of outlets and inlets showing type, size, location, application, and noise level.

PART 2 PRODUCTS

2.1 RECTANGULAR CEILING DIFFUSERS

- A. Connections: Round.
- B. Frame: Provide surface mount and inverted T-bar type. In plaster ceilings, provide plaster frame and ceiling frame.
- C. Fabrication: Steel with baked enamel finish.
- D. Color: As selected by Architect from manufacturer's standard range.

2.2 CEILING SUPPLY REGISTERS/GRILLES

- A. Type: Streamlined and individually adjustable curved blades to discharge air along face of grille, two-way deflection.
- B. Frame: 1-1/4 inch margin with countersunk screw mounting and gasket.

- C. Construction: Made of aluminum extrusions with factory enamel finish.
- D. Construction: Made of stainless steel.
- E. Color: As selected by Architect from manufacturer's standard range.

2.3 CEILING EXHAUST AND RETURN REGISTERS/GRILLES

- A. Type: Streamlined blades, 3/4 inch minimum depth, 3/4 inch maximum spacing, with blades set at 45 degrees, vertical face.
- B. Fabrication: Steel with 20 gage, 0.0359 inch minimum frames and 22 gage, 0.0299 inch minimum blades, steel and aluminum with 20 gage, 0.0359 inch minimum frame, or aluminum extrusions, with factory baked enamel finish.
- C. Color: To be selected by Architect from manufacturer's standard range.

2.4 CEILING LINEAR EXHAUST AND RETURN GRILLES

- A. Type: Streamlined blades with 90 degree one-way deflection, 1/8 by 3/4 inch on 1/4 inch centers.
- B. Frame: 1-1/4 inch margin, extra heavy for floor mounting, with countersunk screw mounting.
- C. Fabrication: Steel with 20 gage, 0.0359 inch minimum frames and 22 gage, 0.0299 inch minimum blades, steel and aluminum with 20 gage, 0.0359 inch minimum frame, or aluminum extrusions, with factory baked enamel finish.
- D. Color: To be selected by Architect from manufacturer's standard range.
- E. Damper: Integral, gang-operated, opposed blade type with removable key operator, operable from face.

2.5 WALL SUPPLY REGISTERS/GRILLES

- A. Type: Streamlined and individually adjustable blades, 3/4 inch minimum depth, 3/4 inch maximum spacing with spring or other device to set blades, vertical face, single deflection.
- B. Fabrication: Steel with 20 gage, 0.0359 inch minimum frames and 22 gage, 0.0299 inch minimum blades, steel and aluminum with 20 gage, 0.0359 inch minimum frame, or aluminum extrusions, with factory baked enamel finish.
- C. Color: To be selected by Architect from manufacturer's standard range.

2.6 LINEAR WALL REGISTERS/GRILLES

- A. Frame: 1-1/4 inch margin with countersunk screw mounting and gasket.
- B. Fabrication: Aluminum extrusions, with factory baked enamel finish.
- C. Color: To be selected by Architect from manufacturer's standard range.

PART 3 EXECUTION

3.1 INSTALLATION

- A. Install in accordance with manufacturer's instructions.

- B. Comply with SMACNA (ASMM) for flashing/counter-flashing of roof penetrations and supports for roof curbs and roof mounted equipment.
- C. Check location of outlets and inlets and make necessary adjustments in position to comply with architectural features, symmetry, and lighting arrangement.
- D. Install diffusers to ductwork with air tight connection.
- E. Provide balancing dampers on duct take-off to diffusers, and grilles and registers, despite whether dampers are specified as part of the diffuser, or grille and register assembly.
- F. Paint ductwork visible behind air outlets and inlets matte black. Refer to Section 09 91 23.

END OF SECTION

This page intentionally left blank

SECTION 23 82 00 - CONVECTION HEATING AND COOLING UNITS

PART 1 GENERAL

1.1 SECTION INCLUDES

- A. Hydronic or steam cabinet unit heaters.

1.2 RELATED REQUIREMENTS

- A. Section 23 07 19 - HVAC Piping Insulation.
- B. Section 23 21 13 - Hydronic Piping.
- C. Section 23 21 14 - Hydronic Specialties.

1.3 SUBMITTALS

- A. See Section 01 30 00 - Administrative Requirements for submittal procedures.
- B. Product Data: Provide typical catalog of information including arrangements.

1.4 WARRANTY

- A. See Section 01 78 00 - Closeout Submittals for additional warranty requirements.

PART 2 PRODUCTS

2.1 HYDRONIC CABINET UNIT HEATERS

- A. Provide products listed, classified, and labeled by Underwriters Laboratories Inc. (UL), Intertek (ETL), or testing firm acceptable to authority having jurisdiction as suitable for purpose indicated.
- B. Coils:
 - 1. Evenly spaced aluminum fins mechanically bonded to copper tubes.
 - 2. Heating Hot Water: Suitable for working temperatures up to a maximum not less than 200 degrees F.
- C. Cabinet: Minimum 16 gauge, 0.0598 inch thick sheet steel front panel with exposed corners and edges rounded, easily removed panels, glass fiber insulation, integral air outlet, and inlet grilles.
- D. Finish: Factory applied baked primer coat on visible surfaces of enclosure or cabinet.
- E. Fans: Centrifugal forward-curved double-width wheels, statically and dynamically balanced, direct driven.
- F. Motor: Tap wound multiple speed permanent split capacitor with sleeve bearings, resiliently mounted.
- G. Control: Factory wired, solid state, infinite speed control, located in cabinet.

- H. Filter: Easily removed, 1 inch thick glass fiber throw-away type, located to filter air before coil.

PART 3 EXECUTION

3.1 EXAMINATION

- A. Verify that surfaces are suitable for installation.

3.2 INSTALLATION

- A. Install in accordance with manufacturer's recommendations.
- B. Install equipment exposed to finished areas after walls and ceilings are finished and painted.
- C. Do not damage equipment or finishes.
- D. Cabinet Unit Heaters:
 - 1. Install as indicated.
 - 2. Coordinate to ensure correct recess size for recessed units.
- E. Units with Hydronic Coils:
 - 1. Provide with shut-off valve on supply piping and tamper-proof, balancing valve with memory stop on return piping.

3.3 CLEANING

- A. After construction and painting is completed, clean exposed surfaces of units.
- B. Install new filters.

3.4 CLOSEOUT ACTIVITIES

- A. See Section 01 78 00 - Closeout Submittals for closeout submittals.
- B. See Section 01 79 00 - Demonstration and Training for additional requirements.

END OF SECTION

SECTION 260000

ELECTRICAL GENERAL PROVISIONS

PART 1 GENERAL

1.01 REFERENCE

- A. The provisions of the Instructions to Bidders, General Conditions, Supplementary Conditions, Alternates, Addenda, and Division 1 are a part of this specification. Contractors and Subcontractors shall examine same as well as other Divisions of the specifications which affect work under this Division.
- B. The requirements of this Section shall govern all Division 25, 26, 27 and 28 work for this project. Bidders are referred to in this section as "Electrical Contractors" and all provisions apply to each contractor and their subcontractors.
- C. The contractor shall be solely responsible for construction means, methods, sequences of construction and the safety of workmen.

1.02 DESCRIPTION OF WORK

- A. Mechanical, Architectural, Structural, Electrical and all other project drawings, as well as the Specifications for all the Divisions, are a part of the Contract Documents. Work of this section is shown on the electrical drawings.
- B. Drawings and Specifications are to be considered as supplementing each other. Work specified but not shown, or shown but not specified, shall be performed or furnished as though mentioned in both Specifications and Drawings. All systems shall be complete and fully operational upon completion of the project.
- C. Contractors shall not construe any correspondence or verbal communications with or by the engineer or his representative as authorization for "extra" construction payment. All requests for additions to this contract shall be submitted in writing by the contractor to the architect for consideration by the owner's representative. Work performed without written change order from the owner will be the contractor's sole responsibility without additional compensation.
- D. Contractor shall comply with and schedule work according to the schedule of construction specified in Division 1. All work shall be completed within these time constraints and the contractors for the work of this section shall provide all required temporary utilities and connections necessary to maintain the existing systems in full operation during the progress of this work. Sections of any systems may be taken out of service only when approved in writing by the owner.

1.03 RELATED WORK SPECIFIED ELSEWHERE

- A. Division 1 - Project Phasing and Temporary Electrical and Telephone Service
- B. Division 9 - Finish Painting
- C. Division 21 - Fire Protection
- D. Division 22 - Plumbing
- E. Division 23 - HVAC

1.04 QUALITY ASSURANCE

A. Codes and Permits:

- 1) Work shall be installed in full accordance with all applicable codes, rules and regulations of public authorities and/or utilities. Included shall be National Electrical Code, NEMA, U. L. Standards, OSHA, State and local Building Codes. All these Codes, Rules and Regulations are hereby incorporated into this specification.
- 2) Comply with specification requirements in excess of Code requirements where no conflicts exist.
- 3) Prior to starting any work, electrical contractors shall secure all necessary permits and inspection certificates required. All fees for permits, utility connection charges, inspections and certificates shall be paid for by electrical contractors.
- 4) Deliver official record of approval, by governing agencies, to architect for transmittal to owner, prior to starting work.

B. Standards:

- 1) Comply with applicable provisions of code approved editions of following National Standards:
 - NFPA 70E Electrical Safety in the Workplace
 - National Electrical Code
 - NFPA Life Safety Code and Standards under
 - Appendix B of Life Safety Code
 - Underwriters Laboratory
 - NFPA
 - NEMA
 - National Electrical Safety Code
 - ANSI
 - Americans with Disability Act

1.05 SUBMITTALS

A. Shop Drawings:

- 1) Contractor shall submit shop drawings of fixtures, distribution equipment, electrical devices, and communication systems for review. Submittals shall be made in a timely fashion, keeping with the project schedule described in Division 1.
- 2) Contractor shall review and indicate his approval of each shop drawing prior to submittal for review. Do not start work until shop drawings have been reviewed by the Engineer and returned to the Contractor. Submittals not indicating contractor approval will be returned without review.
- 3) Submittals will be reviewed only for general compliance with the contract documents and not for dimensions, quantities, etc. The submittal review shall not relieve the contractor of responsibility for purchase of the item in full compliance with the contract documents and its complete and proper installation.
- 4) Where submittals vary from the contract requirements, the contractor shall clearly indicate on submittal or accompanying documents the nature and reason for variations.
- 5) Refer to various sections for listing of shop drawings required on this project which are not listed in A.1 above.
- 6) Each manufacturer or his representative must check the application of his equipment and certify at time of shop drawing submittal that equipment has been properly applied and can be installed, serviced and maintained where indicated on drawings. Advise engineer in writing with submittal drawings of any potential problems. The manufacturer shall be responsible for any changes that might be necessary because of physical characteristics of equipment that have not been called to the engineer's attention at the time of submittal.

B. Record Drawings:

- 1) Each contractor or subcontractor shall keep one (1) complete set of the contract working drawings on the job site on which he shall regularly record any deviations or changes from such contract drawings made during construction.
- 2) These drawings shall record the location of all electrical equipment, junction and pull boxes, conduit routing and all below-grade service. All underground services shall be dimensioned from readily identifiable and accessible building elements.
- 3) Record drawings shall be kept clean and undamaged and shall not be used for any

purpose other than recording deviations from working drawings and exact locations of concealed work.

- 4) After the project is completed, these sets of drawings shall be delivered to the Architect in good condition, as a permanent record of the installation as actually constructed.
- 5) Provide record drawing of one-line power diagram and mount in electrical equipment room.

1.06 COORDINATION AND SUPERVISION

- A. Examine work of other trades which comes in contact with or is covered by the work. Do not attach to, cover, or finish against any defective, or install work of this Division in a manner which will prevent other trades from properly installing their work. Consult all drawings, specifications and details of other Divisions of the work.
- B. Proper clearances for architectural design and equipment access and service shall be maintained for all items and components.
- C. Contractors shall report any interferences between their work and other work or construction as soon as discovered. If contractor proceeds without coordination, correction shall be the responsibility of the installing contractor without cost to the owner.
- D. Drawings are diagrammatic and show approximate location of conduit, devices, etc. Take all measurements and establish exact locations in the field. Adapt to construction and work of other trades as required for coordination of the work.
- E. Each contractor shall be responsible for layout and coordination of openings and chases required for these installations, which are provided by other trades. Provide dimensioned drawing and fully coordinate this work with the contractor providing the openings or chase.
- F. Each contractor shall provide adequate competent supervision on job during all working hours with authority and instructions to answer questions and carry out instructions of Architect or his representative.
- G. All light fixtures and ceiling mounted items shall be centered with regard to ceiling grid at locations shown on the architect's reflected ceiling plan. Failure to observe these requirements shall be cause for correction to be made at the contractor's expense.
- H. The owner and/or architect reserve the right to make reasonable changes in the location of electrical devices, furniture feed connection points, etc. up to the time of roughing-in, without additional cost.
- I. Provide necessary coordination elements, final dimensions, equipment, working clearances,

major conduit runs above and below grade etc. to the Division 250000 HVAC contractor for integration into the coordination drawings.

1.07 DRAWINGS AND SPECIFICATIONS

- A. Drawings and specifications are supplemental to each other. It is intended that work covered by these specifications and drawings include everything requisite and necessary to make the various systems complete and operative, irrespective of whether or not every item is specifically provided for. Any omission of direct reference herein to any essential item shall not excuse contractor from complying with the above intent.
- B. In case of error or inconsistency, specifications shall take precedence over drawings. Figured dimensions supersede scaled ones. Contractor shall take no advantage of, and shall promptly call Architect's attention to any error, omission or inconsistency in specifications and drawings.
- C. Special attention is directed to requirements that equipment and materials stated in specifications and/or indicated on drawings shall be furnished, completely installed, adjusted and left in safe and satisfactory operating condition. Accessories, appliances and connections necessary for proper operation of equipment shall be provided.
- D. Materials, apparatus or equipment specified or otherwise provided for on drawings, addenda, or change orders issued subsequent to award of contract, shall be same brand, type, quality and character originally specified, unless specifically approved by the architect.
- E. Layout of equipment, accessories, specialties and suspended, concealed or exposed piping systems are diagrammatic, unless dimensioned. In preparing shop drawings, contractor shall check project conditions before installing work. If there are any interferences or conflicts, they shall be called to the attention of Architect immediately for clarifications.
- F. The drawings indicate required size and points of termination of conduit and suggest proper routes to conform to structure, avoid obstructions and preserve clearances. However, it is not intended that drawings indicate all necessary offsets and it shall be the work of the installing contractor to make the installation in such a manner as to conform to structure, avoid obstructions, preserve headroom and keep openings and passageways clear, without further instruction or cost to the owner.
- G. It is intended that the electrical items be located symmetrical with architectural elements, and shall be installed at exact height and locations as shown on the architectural drawings. Refer to architectural details in completing and correlating work. Confirm all locations with Architect prior to rough-in.

1.08 PROVISIONS FOR LATER INSTALLATION

- A. Become acquainted with nature and progress of construction against which this work

attaches. Review structural drawings for coordination of openings. Cut no structural members or slabs without Architect's written approval.

- B. When this work cannot be installed concurrently with the building construction, arrange for inserts, sleeves, access panels, etc., as necessary for installation at a later date.

1.09 LOCAL CONDITIONS

- A. Visit site and become familiar with facilities and conditions affecting work. No additional payment will be made on claims that arise from lack of knowledge of existing condition.
- B. Exercise extra care when working in areas where underground services may exist. Any costs for repair of damage to such services become responsibility of Contractor causing damage.

1.10 PROTECTION

- A. When setting up equipment, protect area against staining, abrasion. Cost of correcting any such condition will be charged against the respective Contractor.
- B. Protect all equipment which has been installed from construction debris and the work of other trades.
- C. Protect finish floors from chips and cutting oil by use of chip receiving pan and oil proof cover.
- D. Protect equipment and finished surfaces from welding and cutting spatters with baffles and spatter blankets.
- E. Protect from paint droppings, insulation adhesive, by use of drop cloths.
- F. Contractors shall be responsible for including and maintaining adequate precautions and safeguards related to their work during all phases of construction. Include protection, warnings and safety devices and equipment for protection of personnel, equipment and materials. Comply with all requirements of governing authorities, including OSHA.

1.11 PRODUCT HANDLING

- A. Pay all costs for transportation of materials, equipment to job site.
- B. Provide all scaffolding, tackle, hoists, rigging necessary for placing electrical materials and equipment in their proper place. Remove temporary work when no longer required. Comply with applicable State, Federal and local regulations.
- C. Contractor shall keep materials clean and protected from weather and/or damage before and after installation until final acceptance by the owner. Protect all openings, bearings, controls, motors, etc., from dirt and moisture.

1.12 SHUTDOWNS

- A. Give five (5) working days' notice to Architect or the Owner of anticipated shutdown requirements of an operating system. Tie-ins and modifications to existing facilities and services must be done with minimum interruption of facilities operation and during hours so affecting.

1.13 EXISTING SERVICES

- A. Active services encountered in work shall be protected and supported. Inactive services encountered shall be removed or deactivated as shown or directed by Architect.
- B. All costs for repair of damages to active services shall be paid by the contractor causing the damage.

1.14 TEMPORARY SERVICES

- A. Temporary services shall be provided as stated in Special Conditions and Division 1. Provide all temporary services and connections as required to accommodate the phasing sequence of the project.
- B. Description of System: Furnish and install temporary electrical power service for construction needs throughout construction period in accordance with the special conditions as follows:
 - 1) Provide power for miscellaneous tools and equipment, for pumping, for temporary heating and ventilating and for temporary storage and construction buildings. See General Conditions for requirements of temporary service.
 - 2) Provide temporary lighting of minimum 5 foot candles for safe and adequate working conditions throughout the project, for security and for temporary office and construction buildings.
- C. Materials (General)
 - 1) Comply with Electrical - Basic Materials and Methods.
 - 2) Materials may be new or used, but must be adequate in capacity for required purposes, and must not create unsafe conditions or violate requirements of applicable codes.
 - 3) At Contractor's option, patented specialty products may be used, if UL approved.
 - 4) Provide required facilities, including transformers, conductors, poles, conduits, raceways, breakers, fuses, switches and lighting fixtures with lamps.

- 5) Provide appropriate enclosures for environment in which used, in compliance with NEMA standards.

D. Installation

- 1) Install work in neat and orderly manner.
- 2) Make structurally and electrically sound throughout.
- 3) Maintain to give continuous service and to provide safe working conditions.
- 4) Modify and extend service as work progress requires.
- 5) Locate so that power is available at any desired point with no more than 100' (30.00 m) extension, and with no more than 5% voltage drop at full load.
- 6) Provide circuit breaker protection for each outlet. Provide ground fault interrupting capacity for all circuits.
- 7) Provide equipment grounding continuity for entire system.
- 8) Removal: Completely remove temporary materials and equipment upon completion of construction. Repair damage caused by installation, and restore to specified or original condition.

1.15 OPERATING INSTRUCTIONS

- A. Owner's representative shall be instructed by contractor and manufacturer's representatives on system maintenance and operation requirements. Instruction shall be complete, conducted by qualified service and maintenance specialists. Notify architect of scheduled instruction session to permit his attendance at the session.
- B. The following systems shall include training sessions scheduled with the owner. Allow a minimum of **two (2) one-hour** sessions per system, scheduled one week apart. Include initial programming of all time-of-day set points for operation. Include video record of training sessions.
 - 1) Fire alarm system.
 - 2) Lighting controls.

1.16 DAMAGE AND EMERGENCY REPAIRS

- A. Contractor shall be held responsible for damage to work caused by his work or through the negligence of his workmen. All patching and repairing of damaged work and the cost of same

shall be paid by the contractor causing the damage. All existing facilities and installations shall be restored to their original condition when damaged by the work of this Division, using workmen skilled in each required trade.

- B. The owner reserves the right to make emergency repairs as required to keep equipment in operation, without voiding Contractor's warranty or relieving him of responsibility during warranty period.

1.17 WARRANTY

- A. Electrical Contractors shall warrant all material, equipment, fixtures and workmanship for a period of one (1) year from date of final acceptance.
- B. Any equipment piping, fixture or other component part of system which fails during warranty period and all resulting damage shall be replaced or repaired by contractor without cost to owner.
- C. Warranty on any repairs or replacements shall be extended from date of replacement or repair of that item for one (1) year.
- D. All equipment and fixtures shall be warranted by the manufacturer thru the contract warranty period. Any extended manufacturers warranties shall be extended to the owner.

1.18 REQUIREMENTS FOR FINAL INSPECTION

- A. All of the following items must be completed prior to final inspections. No exceptions will be made and no final payment will be made until all items are completed.
 - 1) Each contractor's foreman shall perform his own punch list and, upon completion, notify the architect that project is ready for final punch list.
 - 2) Thoroughly clean all parts of the apparatus and equipment. Exposed parts which are to be painted shall be thoroughly cleaned of cement, plaster and other materials and all oil and grease spots shall be removed. Such surfaces shall be carefully wiped and all cracks and corners scraped out.
 - 3) Exposed metal work shall be carefully brushed down with steel brushes to remove rust and other spots and left smooth and clean.
 - 4) All labeling of system components as required in this Section and Section 260500, the drawings and the owner shall be complete.
 - 5) All system start ups shall be complete with written certifications submitted for all systems and major equipment.

- 6) Certification of test and start-up and training sessions for the systems listed in operating instructions.

PART 2 PRODUCTS

2.01 MATERIALS

- A. Provide material and labor which is neither drawn nor specified but which is obviously a component part of and necessary to complete work or comply with code, and which is customarily a part of work of similar character.
- B. Provide incidental concrete, trenching and backfilling, reinforcing steel, masonry, mortar, miscellaneous steel, painting and the like required to complete electrical installations; perform in manner specified in applicable Division of General Trades Specification by workmen skilled in that particular trade.
- C. All equipment and material shall be new, free from defects, U.L. listed where applicable and warranted by the manufacturer and the contractor.
- D. To the greatest extent possible, provide materials and products of the same kind from the same manufacturer for this project.

2.02 MATERIAL SUBSTITUTIONS

- A. All changes required by substitutions, such as revisions to foundations, bases, conduit, controls, wiring, openings and appurtenances shall be made by the substituting contractor at no additional cost to the project. Notify all other contractors affected by substitution and pay all costs related to the substitution incurred by other contractors.
 - 1) Refer to General Conditions and Division I for requirements related to material and equipment substitutions.
- B. Systems have been laid out around particular fixtures and equipment considered base items. Manufacturer **first** listed is base item. Other named manufacturers in these specifications or on the drawings who can provide equivalent equipment are acceptable and may be bid, provided performance, construction, components, quality and appearance, where applicable, are equivalent to base item and can be properly installed. Acceptable alternate makes of equipment are listed in specifications or equipment schedules; however, manufacturers other than base manufacturers are substitutions and shall comply with the following paragraphs. When distribution equipment is substituted, contractor shall submit equipment room shop drawings showing dimensions of equipment and required N.E.C. clearance. It is the contractors sole responsibility that all substituted equipment fits in the allotted space and maintains all required clearances.
- C. Should the contractor propose to furnish materials or equipment other than those listed in the

specification, a written request for substitution shall be submitted as an alternate to the base bid at the bid opening. Refer to General Conditions Division of this specification. It is the contractor's responsibility to fully evaluate substitutions and ascertain that the substitution is equivalent in all respects to the base specification prior to submittal.

- D. Substitutions are subject to approval of Architect and his decision shall be final. In submitting substitutions, include make and model number and complete literature and performance data for evaluation.
- E. Substitution of items not named in these specifications or drawings may be offered for consideration on the substitution sheet included in the Proposal Form of the contract, under the following conditions:
 - 1) The proposed substitution is proven, to the satisfaction of the Project Architect and Engineer, to be equal or superior to the specified item in all respects.
 - 2) Extended delivery schedules on specified items, which would delay timely completion of the job, will be cause for consideration of substitutions. The Contractor must show proof of delay in delivery from the manufacturer.
 - 3) Changes required by substitution, such as revisions to foundations, bases, conduit, controls, wiring, openings and appurtenances shall be made by the Contractor at no additional cost to the project and pay all costs related to the substitution incurred by other contractors.
 - 4) State the amount of credit to be given to the owner if the substitution is accepted prior to contract award on the proposal form substitution sheet or if after award of contract, submit a quotation stating cost reduction resulting from acceptance of a substitution if executed through a contract change order.
 - 5) Manufacturers of items not named in these specifications or drawings may submit a written request with supporting product information to the engineer ten (10) days prior to the project bid date for consideration at the sole determination of the engineer to become a named product. If approved, the product name will be added to the list of substitute manufacturers in a written addendum issued by the architect to bidders.

PART 3 EXECUTION

3.01 INSTALLATION REQUIREMENTS

- A. Location of conduit, equipment, devices, etc., on the drawings are diagrammatic; indicated positions shall be followed as closely as possible, exact locations shall be subject to building construction and interferences with other work. Difficulties preventing the installation of any part of work as indicated shall be called to the attention of the Architect. Architect shall determine locations and changes, Contractor shall install the work accordingly. Architect

reserves right to make minor changes in location of any part of the work up to the time of roughing-in without additional cost.

- B. All materials and equipment shall be installed in a neat and workmanlike manner by competent specialists for each subtrade. The installation of any materials and equipment not meeting these standards may require removal and reinstallation at no additional cost to the Owner.
- C. Install, connect equipment, services, materials in accordance with best engineering practice and in conformity with manufacturer's printed instructions and U.L. Listing.
- D. Take all measurements and determine all elevations at the building prior to fabrication or rough-in.

3.02 CUTTING AND PATCHING

- A. Perform all cutting, framing and patching in completed construction as necessary for installation of this work. Do not cut any structural member or structural floor slab without written permission from the Architect. Have cutting done by skilled mechanics as carefully as possible, and with as little damage as possible. Have patching done by first-class mechanics, skilled in the several trades.
- B. In new construction, lay out location and size of all openings to be provided by other trades in advance of their work. Set sleeves, lintels, etc., for openings and provide layout dimensioned drawings as required for coordination with other contractors. If openings information and sleeves are not provided to other trades in advance of their work, this contractor shall provide all required openings as required for existing construction.
- C. In existing construction, contractor shall perform all cutting, patching and framing of chases and openings required by this work. Properly sized structural lintels shall be provided above masonry wall openings and steel angle frames around panel walls, floor or roof openings. Size lintels and frames per schedule on architectural or structural plans.
- D. Perform all excavation and backfill required for installation of below-grade conduits. Excavate to depth required to install conduits at required level and pitch. All backfill shall be compacted in maximum twelve (12) inch layers and conform to all bearing requirements of site and/or structure above. Trenches for utility services shall comply with the specifications and details of the utility company.
- E. All conduits for below-grade entry of the building shall be pitched away from the building floor elevation and sealed to prevent water entry.
- F. All openings shall be cut with lintels and frames installed by workmen skilled in the particular trade.

- 1) All patching shall be by a skilled general trades contractor and shall be performed in accordance with requirements of Division 9.
 - 2) All roof cutting and patching installed under this contract shall be performed by the project roofing contractor at this contractor's expense.
- G. Core drill round openings and neatly saw cut rectangular openings in floors or walls. Sleeves shall be grouted or patched to match existing wall or floor construction.
- H. Sleeves for floor or wall penetrations shall extend 2" past opening and be grouted in place and sealed watertight with silicone caulk.

3.03 FIRE STOPPING

- A. Where steel conduits pass through fire rated walls, set sleeve in wall, install non-shrinking grout between conduit and sleeve. Fire seal around wall sleeve with fire rated sealant. All penetrations shall be protected or rated construction in accordance with an approved method listed in the U.L. fire resistance directory.
- B. Where conduits pass through floors, set steel sleeve in floor slab. Top of sleeve shall be 2" above finish floor and shall be grouted in place and sealed watertight to floor. Fire seal between sleeve and conduit.
- C. Penetrations of fire rated walls and ceilings by exposed cabling system shall be made with steel conduit sleeves, fire stopped with U.L. listed sealant per U.L. assembly drawings.
- D. Fire rated sealant shall be U.L. listed and applied in accordance with the U.L. assembly requirements and the manufacturer's recommendations to match the rating of the penetrated structure. Sealants shall be as manufactured by Hilti, International Protective Coatings (IPC), Specified Technologies, Inc. (STI), or 3M.

3.04 ACCESS DOORS

- A. Proper access for service and maintenance shall be ascertained before installation of any item. The electrical contractor shall furnish access doors adequately sized for servicing concealed items furnished under this contract. Doors shall be fire rated where installed in rated construction and shall have concealed hinge door, screw drive latch and primed painted finish. Frames shall match the construction of adjoining surfaces.
- B. Doors in new construction shall be furnished to general trades contractor for installation. In existing construction, doors shall be installed by the electrical contractor with surrounding surfaces patched and painted to match existing.
- C. Access doors shall be as manufactured by Milcor or approved equivalent.

3.05 PAINTING

- A. Finish painting is included under Division 9 - Finishes, except where specifically called for under this Division.
- B. Certain painting specified as part of the electrical Trades Work is included herein and shall comply with Division 9.
- C. Materials and equipment installed under this Division shall be left free from dirt, grease and foreign matter, ready for painting.
- D. No equipment or piping shall be painted before being tested.
- E. Damaged surfaces of prefinished materials and equipment shall be touch-up painted to match existing finish by the contractor.
- F. All items to be painted shall be primed and painted with two (2) coats of rust inhibitive paint on exterior and enamel paint on interior in accordance with the paint manufacturer's instructions. Engineer shall select a custom color.

3.06 EQUIPMENT IDENTIFICATION

- A. Equipment:

Push buttons, selector switches, safety switches, motor starters, time switches, contactors, panelboards, pull boxes, cabinets, special outlets, etc., shall be identified as to function with a phenolic engraved nameplate securely attached. Identify voltage, phase, origin and load served.
- B. Panelboards:

Provide typed directories for distribution and circuit breaker panels describing load fed and location. Typed directories shall include specific load location information with final room names and numbers (i.e., Receptacles - Office 120).
- C. Nameplates shall be laminated phenolic with a black surface and white core and shall be mechanically fastened with screws to each item. Use 1/16" thick material for plates up to 2"x4". For larger sizes, use 1/8" thick material. Lettering shall be minimum 1/4" height, spaced at four (4) per inch. Safety switches, motor starters, and panelboard nameplates shall include system voltage, phase and wire count, i.e. Panel "A" - 208Y/120, circuit origin and load served.
- D. Wiring:
 - 1) Color code all wiring in accordance with NEC Standards. All system and control

wiring shall be labeled at each termination and splice, and continuously color coded.

- 2) Color coding is to be plainly labeled on all wiring diagrams submitted for approval and wire installed by this contractor shall comply with manufacturer's wiring diagram requirements.
- E. Label all conduits leaving main panelboards where exposed with stick-on labels indicating circuit contained.
- F. Label all junction boxes with circuits contained with indelible marker. Color code emergency and fire alarm system box covers as directed with permanent paint markings. Mark conduit at 48" intervals where visible, or use pre-finished color coded conduit, exposed or above accessible ceilings.
- G. Label inside of device plates with panel and circuit number.

3.07 OPERATING AND MAINTENANCE MANUAL

- A. Prepare one (1) complete operating and maintenance manual in hardback binder describing operation of the systems and recommended maintenance schedule. Turn all equipment warranties over to the Owner. Quantity of manuals shall be confirmed with the owner.
- B. Manuals shall be indexed, arranged in the CSI format, and include:
 - 1) Job name and names of contractor with address and telephone number for service. Include all major emergency service numbers for equipment and generator set particularly.
 - 2) Manual index.
 - 3) Identification, name, mark, number as indicated on design drawings.
 - 4) Normal equipment operating characteristics.
 - 5) Performance data and ratings.
 - 6) Wiring diagrams.
 - 7) Manufacturer's descriptive literature.
 - 8) Manufacturer's maintenance and service manuals. Include signed copies of attendance sheets for each owner instruction session.
 - 9) Spare parts and replacement parts list for each piece of equipment.

10) Name of service agency and installer.

11) Final accepted shop drawings.

C. Include entire manual in digital format and storage device, as required by the owner.

3.08 CLEANING UP

A. From time to time during the operations and at completion thereof, electrical contractor shall remove from the premises all debris and excess material caused by their work. Area of operation shall be left broom clean.

B. Construction materials shall be neatly stored in project areas and locations designated by the owner and architect. Construction materials must not be left scattered about construction area.

C. All electrical equipment to be painted by others shall be thoroughly cleaned by electrical contractors of grease, rust, shipping tags and construction dirt.

3.09 TEST, CHECK, START AND BALANCE

A. The electrical contractor shall test, check and start up all systems installed under this contract and place them in operating condition. Testing may be done by qualified employees of the contractor except where independent testing company is specified (see paragraph F. below).

B. All light fixtures, panels and electrical equipment shall be cleaned and labeled.

C. Circuits shall be phased out and connected to the panel or main switch in proper manner. Loads shall be distributed within 5% between phases when all loads are energized. All wires shall be entirely free from grounds and short circuits.

D. Distribution voltages shall be checked by this contractor who shall advise the engineer in writing in the event that incoming voltages are not within a tolerance of plus or minus 5% of nominal value. Adjust taps on transformer if required to correct voltage variations or coordinate with serving utility to adjust incoming service voltage.

E. Upon completion of the work, deliver to owner all special tools, keys, fuses and other detachable portions of the electrical system. Obtain written receipt from owner's representative and submit to architect with request for final payment.

F. Include all time required for LEED commissioning time. Coordinate with the commissioning agent.

3.10 DEMOLITION

- A. This contractor shall perform all demolition of existing electrical systems as indicated on electrical and architectural plans or necessary for project. Remove from site and properly dispose of all material and debris from this work.
- B. Demolition drawings are general in nature showing the scope of demolition work. Contractor shall visit the site and become familiar with the quantity of light fixtures, outlets, etc. Remove all equipment and devices no longer required for finished construction. All existing lights, conduit, wire and devices in project areas shall be removed and disposed of. Remove conduits beyond new surfaces. Remove all existing wire from conduit back to point of common use or to panels. Label existing circuit breakers "spare" if not reused for new work.
- C. Disconnect existing equipment in building that is to be removed under other sections.
- D. Patch all surfaces to match surrounding for devices to be removed from existing walls to be maintained.
- E. The electrical contractor is to inspect existing conditions and equipment for current code violations and include in bid the amount to correct these violations.
- F. The owner reserves the right of salvage for all existing electrical equipment. Prior to demolition, the contractor shall review all materials and deliver to the owner those required in their existing condition. All other material shall be removed by this contractor.
- G. All circuits which are required to remain active shall be maintained or reworked as required.

END OF SECTION

SECTION 260500

BASIC MATERIALS AND METHODS

PART 1 GENERAL

1.01 REFERENCE

- A. Drawings and general provisions of contract, including General and Supplementary Conditions and Division 1 specification sections apply to work of this section.
- B. Division 26, Section 260000, Electrical General Provisions, apply to work of this section.
- C. Division 22 - Plumbing.
- D. Division 23 - HVAC.

1.02 CONTENTS

- A. Specified Herein: Requirements for basic electrical materials, equipment and wiring methods.
- B. Described herein are the following:

- Scope
- Safety Switches
- Wiring Devices
- Wall Plates
- Connectors, Lugs, Taps and Splices
- Junction and Pull Boxes
- Outlet and Switch Boxes
- Conductors
- Conduit

1.03 SCOPE

- A. The work under this section shall comprise, but is not necessarily limited to the following:
 - 1) Provide all labor and material required to install a 277/480 volt and a 120/208 volt interior wiring system, utilization outlets, motor starters, disconnect switches and fuses.

1.04 PRODUCT DELIVERY, STORAGE AND HANDLING

- A. Storage Conditions: It is recognized that space at the project for storage of materials and products may be limited. Coordinate the deliveries of electrical materials and products with the

scheduling and sequencing of the work so that storage requirements at the project are minimized. In general, do not deliver individual items of electrical equipment to the project substantially ahead of the time of installation. Limit each shipment of bulk and multiple use materials to the quantities needed for installations within three (3) weeks of receipt.

- B. Handle all electrical material carefully to prevent damage, dents or marring of the finish.
- C. Protection and Identification: Deliver products to project properly identified with names, model numbers, types, grades, compliance labels and similar information needed for distinct identification; adequately packaged or protected to prevent deterioration during shipment, storage and handling. Store in a dry, well ventilated, indoor space, except where prepared and protected by the manufacturer specifically for exterior storage.
- D. Do not install damaged material. Remove from the project site.

PART 2 PRODUCTS

2.01 SWITCHES, SAFETY

- A. Safety switches shall be heavy duty, sheet steel enclosed, of the type, size and electrical characteristics indicated, surface mounted, fusible rated at 250 volts on the 208 volt system and 600 volts on the 480 volt system, ampere ratings as required for the application or as noted on the drawings, 60 Hertz, 3 blades, incorporating quick-make, quick-break type switches, constructed so switch blades are visible in "OFF" position with door open; equipped with operating handle which is easily recognizable, and is padlockable in the "OFF" position; with current carrying parts constructed of high-conductivity copper and silver-tungsten type switch contact; with positive pressure type reinforced fuse clips. All switches shall be of the same manufacturer. Handle shall be interlocked so switch cannot be opened in the "ON" position.
- B. Fuses: Unless indicated on the drawings as non-fused type, provide fuses for safety switches, as recommended by the switch manufacturer of class, type and rating needed to meet electrical requirements.
- C. Disconnects for 120 volt, single phase equipment shall be heavy duty type suitable for the service intended. Include thermal overload protection integral with disconnect for motors or where required by code. Thermal protection in the disconnect may be deleted where motors have integral thermal protection.
- D. Switches installed in outdoor locations shall be weatherproof NEMA 3R.
- E. All disconnects shall have provisions for padlocking in the off position to comply with owner's lock-out tag-out procedures.
- F. Switches manufactured by the following will be acceptable:

Square "D" - Type Heavy Duty
Siemens - Type HD
Eaton - Series "K"
ABB - Type TH
Submit complete shop drawings.

2.02 FUSES - 600 VOLTS AND LESS

- A. Fuses shall not be installed until equipment is ready to be energized. All fuses shall be of the same manufacturer to assure selective coordination.
- B. The electrical contractor shall furnish and install a complete set of fuses for all fusible equipment on the job. Unless otherwise noted all fuses shall be U.L. listed, current-limiting and have an interrupting rating of 200,000 RMS amperes symmetrical.
- C. All fuses rated 601 amperes or greater shall be time-delay current-limiting U.L. Class L, unless otherwise noted. They shall be:

Bussman HI-CAP-KRP-C-600V
Mersen Amptrap A4BQ

- D. All fuses rated 600 amperes or less shall be time-delay current-limiting U.L. Class RK1, unless otherwise noted. They shall be:

Mersen Amptrap 2000; A2DR (250V), A6D-R (600 V)
Bussman Low Peak; LPN-RK (250V), LPS-RK (600 V)
Littel Fuse; LLNRK (250 V)

- E. All fusible equipment rated 600 volts or less and 600 amperes or less shall be equipped with factory installed Class "R" rejection clips unless otherwise noted.
- F. Spare fuses amounting to 20% (minimum three) of each type and rating shall be supplied by the electrical contractor. These shall be turned over to the Contracting Officer upon project completion.

2.03 WIRING DEVICES

- A. General: Provide factory-fabricated wiring devices, in type, color and electrical rating for the service indicated. Type and grade shall be as described in the following paragraphs and in the symbol legend on the drawings.
- B. Receptacles: Comply with NEMA Standards Publication No. WD1 and Federal Specification WC 596-F, and as follows:

Heavy Duty Duplex: Provide duplex heavy-duty type receptacles, 2-pole, 3-wire grounding, with green hexagonal equipment ground screw, ground terminals and poles internally connected to mounting yoke, 20-ampere, 125 volts, with metal plaster ears, back and side wired, with side screws providing clamping action of the back wiring slots, NEMA configuration 5-20R, unless otherwise indicated.

Heavy-Duty Single: Provide single heavy-duty type receptacles, 2-pole, 3-wire grounding, with green hexagonal equipment ground screw, ampere and voltage rating as shown on drawings, with metal plaster ears, back and side screws providing clamping action of the back wiring slots, NEMA configuration to match equipment caps. Receptacle to be twist-lock type where both cap and receptacle are provided by this contractor.

Heavy-Duty Clock Single: Provide single general-duty type receptacles, 2-pole, 3-wire grounding, 15 ampere, 125 volts, recessed to contain male plug and permit clock to cover outlet, with metal hook for supporting clock, brown, side wiring, NEMA configuration 5-15R, complete with stainless steel plate.

GFCI: Provide heavy-duty, duplex, ground fault circuit interrupter receptacles, feed-through type, capable of protecting connected downstream receptacles on single circuit, grounding type, UL rated Class A, Group 1, 20 ampere rating, 125 volts, 60 Hertz; with solid state ground fault sensing and signaling; with five (5) milliampere ground fault trip lever; equipped with 20-ampere plug configuration, NEMA 5-20R. When GFCI becomes inoperable, unit shall fail in the safe position (off) and interrupt power. Units that use lights or sounds are not acceptable.

- C. Switches: Comply with NEMA Standards Publication No. WD1 and Federal Specification Test WS-896E, and as follows:

Snap: Provide heavy-duty flush single-pole toggle switches, 20 ampere, 120/277 volts AC, with mounting yoke insulated from mechanism, equipped with plaster ears and side-wired screw terminals.

3-Way Snap: Provide heavy-duty flush 3-way toggle switches, 20 ampere, 120/277 volts, with mounting yoke insulated from mechanism, equipped with plaster ears and side-wired screw terminals.

- D. In general, all wiring device colors shall be verified with architect and have smooth finish stainless steel plates with openings to match devices. Contractor shall provide custom color receptacles and any plate material selected by architect and furnish at no additional cost to the contract.
- E. Wiring devices and plates shall be as manufactured by Hubbell, P & S or Leviton
- F. The contractor shall submit a device schedule for selection of colors with shop drawings, along with a sample of the manufacturer's standard device colors. Schedule shall include

each room of the project and read as follows:

<u>Room No.</u>	<u>Room Name</u>	<u>Device Color</u> (by architect)
-----------------	------------------	---------------------------------------

- G. Devices with proprietary quick connect back-wiring pigtails are not permissible.

2.04 CONNECTORS, LUGS, TAPS AND SPLICES

- A. Joints in #10 AWG and smaller wire shall be made with Minnesota Mining and Manufacturing Company insulated "Scotch Locks", Ideal Company "Wing Nut", or T & B Company "Piggy Connector".
- B. Joints in #8 AWG and larger shall be made with pressure type mechanical connectors and insulated with electrical tape or manufacturer's insulation kit to 200% of the insulating value of the conductor insulation.
- C. Straight taps to be ILSCO SPA Series or equal. Taps of multiple and parallel conductors are to be made with mechanical connectors listed for the quantity and size of conductors, ILSCO Type PTA or IPC or equal.
- D. Splices may be made with long barrel compression sleeve connectors insulated to 200% of cable rating. Compression connectors to be long barrel type, ILSCO Type CTL or equal.
- E. Lugs to be mechanical type connectors of size and ampacity to match service used. Provide compression lugs where required by equipment installed. Compression lugs to be long barrel, heavy duty type.
- F. All materials for copper wiring shall be copper.

2.05 JUNCTION AND PULL BOXES

- A. Furnish and install junction and pull boxes wherever required or otherwise necessary to facilitate installation of other equipment. Junction boxes shall be galvanized finished sheet steel of code thickness, of ample size to properly enclose the conductors terminating in or passing through them, sized in accordance with NEC 370 or as noted. Junction boxes shall not be placed in locations made inaccessible by piping, ducts or other equipment and locations shall be as approved by the A/E.

2.06 OUTLET AND SWITCH BOXES

- A. Furnish and install outlet boxes of proper type and size as required at outlets where required, secured firmly in place and set true and square and flush with the finished surfaces. Boxes shall be rigidly supported from the building structure independent of the conduit system. Boxes cast into masonry or concrete are considered to be rigidly supported.

- B. All boxes for lighting outlets shall be provided with fixture studs of a size suitable for the weight of the fixture to be supported. The stud shall be of integral construction with the box, or of the type which is inserted from the back of the box. In no case shall the weight of the fixture be dependent upon bolts holding the stud to the box.
- C. Outlet boxes for exterior work shall be of cast, rust resistant metal. Gasketed covers shall be provided where outlet is exposed to weather or moisture.
- D. Wiring device boxes for surface conduit work shall be FS Series cast type.
- E. Outlet and switch boxes shall be four (4) inch square minimum with plaster ring as required. All communications outlets shall be 2-1/8" deep minimum.

2.07 CONDUCTORS

- A. All wire shall be in strict accordance with the applicable standards and shall be delivered on site with original factory tags attached and shall be less than one (1) year old when installed.
- B. Except as specifically designated otherwise, no wire smaller than No. 12 AWG copper shall be used. Generally, all wire and cable sizes are shown, either directly or by implication that no marking designates No. 12 size. In the event that size is not indicated for a feeder or motor run, which obviously could not be interpreted as No. 12, the wire size shall conform to the sizing for the rating of the service protective device.
- C. Single conductor 600 volt wire shall be copper and be equal to or better than THW, THWN/THHN or XHHW specifications. Wire shall be rated for 75 degrees C. maximum temperature in dry locations and 90 degrees C. in wet locations and below grade. Wire shall be listed by UL and conductor identification shall include size, voltage manufacturer's name and number, UL listing and wire type.
- D. Wire sizes up to No. 10 AWG shall be solid, No. 8 AWG and larger, stranded.
 - 1) Use stranded conductors for motors and other connections subjected to vibration.
 - 2) 90 degree C. wire shall be used from outlet boxes to light fixtures.
 - 3) Color code wiring in accordance with N.E.C. standards. In existing facilities, match facility standards.
 - a. Phase conductors on the 120/208 volt system shall be black, red, blue for Phase A, B, C respectively. Ground conductor shall be green and neutral shall be white.
 - b. Phase conductors on the 277/480 volt system shall be brown, orange, yellow

for Phase A, B, and C respectively. Ground conductors shall be green with yellow stripe and neutral conductor shall be gray.

- E. Conductors smaller than #12 AWG shall be allowed for use on fire alarm system and other control systems only. In general, #18 AWG shall be used for initiating devices and #14 AWG for indicating circuits.
 - 1) Wire shall be 600 V copper Type TF or TFN solid or seven (7) strands maximum for #18 and #16 and nineteen (19) strands maximum for #14 AWG.
 - 2) All wire types shall conform to the U.L. listing requirements of equipment connected and shall be coordinated with equipment installed.
 - 3) All wire shall be continuously color coded for entire length of circuit. Conductor color coding shall be clearly noted on all wiring diagrams and instruction manuals. Match facility standards where applicable.
 - 4) Type FPL cable shall be allowed for fire alarm system installation where concealed, where allowed by local code officials and the owners. If this use is not verified prior to bid, it shall be considered a substitution to conduit and wire.
- F. All ground conductors shall be green on the 120/208 volt system and green with a continuous yellow stripe on the 277/480 volt system. All neutral conductors shall be white on the 120/208 volt system and gray on the 277 volt system. Where neutrals of different voltage systems share the same conduit, they shall be of different colors (as allowed by the NEC) and labeled at all junction and outlet boxes.
- G. Wire shall be as manufactured by Southwire, General Cable, Pirelli, Essex, Continental or other approved manufacturer.

2.08 POWER AND CONTROL WIRING - BUILDING FACILITIES

- A. Electrical Contractor shall provide all single phase and three (3) phase (unless noted) power wiring in conduit to all motors and equipment. In general, all motors 1/2 hp and larger will be rated three (3) phase, while smaller motors will be rated single phase unless otherwise noted on drawings.
- B. Provide each motor with a disconnecting means as required by the National Electrical Code, unless furnished with equipment. All devices on building exterior shall be weatherproof type and conduit and supports shall be rigid aluminum. Where disconnect switches are furnished with mechanical equipment, the electrical contractor shall mount and wire those devices.
- C. Provide all power and interlock wiring for mechanical equipment, along with conduit and wires for control system where specifically shown on electrical drawings. Mount all control devices furnished by mechanical contractor and wire per manufacturer's wiring diagrams.

- D. This contractor shall review mechanical shop drawings and indicate his approval of all mechanical equipment voltages and horsepowers prior to any equipment being released. Failure to do so shall require any revisions to wiring systems, etc., to be revised at the contractor's expense.
- E. The wire size and number of conductors for all control wiring shown on plans shall be as required by the manufacturer's shop drawings. No wire shall be pulled based on fill shown on plans.
- F. Wire all motorized dampers at associated fans.
- G. Coordinate conductor sizes shown on drawings with the required terminations on mechanical equipment. Advise mechanical contractor of required terminations. Provide lug kits to terminate conductors shown on drawings where required.

2.09 CONDUIT

- A. General: All medium and low voltage wiring to be installed in metal conduit or tubing with fittings of type, grade, size and weight (wall thickness) indicated for each service. Where conduit type and grade are not indicated below, conduit shall be rigid galvanized steel and comply with National Electrical Code for electrical raceways. Minimum size conduit shall be 1/2" unless otherwise noted. No conduit shall be run in or through ductwork. All conduit shall bear the U.L. label.
- B. Intermediate Metal Conduit: Conduit shall be hot dipped galvanized intermediate metal conduit conforming to Federal Specification WW-C-581 and ANSI C80.1.

Location: Exposed interior subject to damage.
- C. Electrical Metallic Tubing (EMT): Conduit shall be zinc coated steel electrical metallic tubing conforming to Federal Specification WW-C-563 and ANSI C80.3. All EMT conduit stubs for communications wiring shall have a plastic bushing at both ends.

Location: In stud walls or above ceilings. Exposed interior not subject to damage.
- D. Flexible Metal Conduit: Conduit shall be manufactured of heavily zinc coated sheet metal strips interlocked to form a flexible, smooth wiring channel. Federal specification WW-C-566

Location: Motor connections subject to vibration, light fixtures (six feet in length), and transformer connections.
- E. Liquid-Tight Flexible Metal Conduit: Provide liquid-tight flexible metal conduit comprised of single strip, continuous, flexible, interlocked, double-wrapped steel, galvanized inside and outside; forming smooth internal wiring channel; with liquid-tight jacket of flexible polyvinyl

chloride (PVC) (maximum length 5'-0") conforming to U.L. 360. Conduit shall be Anaconda "Sealtite" or "Electri-Flex."

Location: Motor connections subject to vibration in wet areas and all connections to all outdoor equipment.

- F. Underground Conduit: Schedule 40 direct burial Type PVC conforming to UL 651, NEMA TC2-1978 and Federal Specification WC-1094A. and shall include a green ground wire with the circuit conductors. Conduit to be Carlon Plus 40 or approved.

Location: Direct buried conduits.

- G. Underground Conduit: Concrete encased conduit to conform to UL-651-A, NEMA TC-6 and ASTM F-512. Conduit to be Carlon Type EB or approved.

- H. Rigid Aluminum Conduit: Rigid aluminum conduit conforming to Federal Specification WW-C-540c and U.L. UL-6.

Location: Exterior or conduit exposed in wet or damp atmosphere.

- I. Type MC Cable: Multi-conductor cable assembly with overall aluminum flexible cover, UL Standard 1569 and Art. 334 of NEC. All cables to include ground.

Location: Concealed in stud spaces and above accessible ceilings, for final connections to devices and fixtures, and where fished in existing construction.

2.10 CONDUIT FITTINGS

- A. Conduit fittings for exposed work shall be rust resistant. Castings shall provide ample wiring space, shall have smooth round edges and full-threaded hubs.
- B. Fittings shall be as manufactured by Crouse Hinds Appleton, Killark, or approved manufacturer.
- C. EMT and IMC conduit fittings, connectors and couplings shall be steel set screw or compression type (no pot metal or zinc) as manufactured by OZ/Gedney, T & B or equal.
- D. Rigid aluminum fittings to be threaded aluminum.
- E. All conduit fittings shall be U.L. listed for conduit material, in particular, for transition from one material to another.

PART 3 EXECUTION

3.01 INSPECTION

- A. Installer must examine the areas and conditions under which electrical work is to be installed and notify the contractor in writing of conditions detrimental to the proper and timely completion of the work. Do not proceed with the work until unsatisfactory conditions have been corrected in a manner acceptable to the installer.

3.02 ELECTRICAL INSTALLATIONS

- A. General: Install electrical equipment for this project as indicated, in accordance with the manufacturer's written instructions, the applicable requirements of NEC and the National Electrical Contractors Association's "Standard of Installation", and in accordance with recognized industry practices to ensure that products serve the intended functions.

3.03 SAFETY SWITCHES

- A. Install disconnect switches used with motor-driven appliances and motors and controllers within sight of the controller position unless otherwise indicated.
- B. Do not install switches on equipment to obstruct unit nameplates or access panels. Exact locations are to be coordinated in field.
- C. Install disconnect switches furnished as accessories to mechanical equipment. Where equipment is served by a variable frequency drive, provide label on switch: "Do not open when equipment is energized variable frequency drive."

3.04 PULL, JUNCTION, OUTLET AND SWITCH BOXES

- A. Install electrical boxes as indicated, or in compliance with NEC requirements, in accordance with the manufacturer's written instructions and with recognized industry practices to ensure that the boxes and fittings serve the intended purposes.
- B. Provide weatherproof outlets for interior and exterior locations exposed to weather or moisture exposure. Boxes shall be rigid aluminum.
- C. Provide knockout closures to cap unused knockout holes where blanks have been removed.
- D. Locate boxes and conduit bodies so as to ensure accessibility of electrical wiring.
- E. Avoid using round boxes where conduit must enter box through side of box, which would result in a difficult and insecure connection with a lock nut or bushing on the rounded surfaces.
- F. Secure boxes rigidly to the substrate upon which they are being mounted, or solidly embed boxes in concrete or masonry.

- G. Pull boxes shall be sized per code and located at maximum 100 foot centers on long runs where accessible. All wire splices shall be made in outlet or pull boxes.
- H. Conduit crossings of building expansion joints shall have expansion fitting with grounding continuity.
- I. Grade accessible pull boxes shall be installed flush with finished grades or paving. Boxes shall have open bottom and be installed on an 8" gravel sub-drain as detailed. All conduit penetrations of boxes shall be made with bell ends on conduits and be with an expanding mortar such as "Water Plug". The entire installation shall comply with the manufacturer's recommendations.
- J. Where multiple switches are installed adjacent to one another, multiple gang boxes shall be used with single cover and barriers between 277 volt and 120 volt circuits, where required.
- K. All spaces around boxes not covered by cover plate shall be filled to match surrounding finish work. Provide oversized covers on all flush devices in masonry walls.
- L. Coordinate all outlet and switch locations with finish millwork so as not to cut or damage trim, as directed by architect.

3.05 WIRING DEVICES AND PLATES

- A. All mounting heights shall be subject to checking with the details shown on the architectural drawings and with the A/E and locations shall be verified through the A/E before installing wiring, apparatus, etc.
- B. Delay installation of devices until wiring is completed.
- C. Install receptacles and switches only in electrical boxes which are clean; free from excess building materials, debris, etc.
- D. Install plates after wall finish work is complete.
- E. Prior to project completion, replace those items which have been damaged during construction.
- F. Test wiring devices to ensure electrical continuity of grounding connections, and after energizing circuitry, to demonstrate compliance with requirements.

3.06 CONDUCTORS AND CONDUIT

- A. General: Except as indicated hereinafter or on the drawings, all wiring above ceilings and in stud walls shall be done with insulated conductors in electrical metallic tubing (EMT). Wiring exposed on walls and in areas subject to damage shall be insulated conductors in

intermediate metal conduit (IMC) and wiring for feeders buried in earth shall be insulated conductors in rigid Schedule 40 PVC, 24" below finished grade (minimum).

- B. Conduit Installation: Conduit sizes, type and length shall be furnished and installed as required by the drawings and as specified in these specifications.

The drawings indicate generally the size and location of the conduits. Conduits not shown but obviously required shall be run where directed, of sizes as approved by the A/E. The conduit system shall connect all outlet boxes, junction boxes, panelboards, cabinets, push button stations, motors, etc.

- C. Field bends and offsets shall be uniform and symmetrical, without conduit flattening or finish scarring. Minimum bend radii shall be as required by the NEC, but in no case less than six (6) times conduit diameter.
- D. Conduit found unacceptable while on the job before installation shall be removed from the premises upon notice.
- E. Approved pipe plugs or caps shall be installed in conduit before pouring of concrete. Conduit shall also be kept dry and free of water and debris by means of plugs or caps.
- F. Where conduit enters through exterior concrete walls or below grade footings, the entrance shall be made watertight. Pipe sleeves shall be provided in the concrete with 1/2" minimum clearance around the conduit for an entrance seal similar to O.Z. Type FSK or Link Seal mechanical seal fittings. Conduits shall be sloped away from building and sealed inside the conduit after conductor installation to eliminate water and condensation infiltration. Contractor shall use Polywater FST or Raychem "RDSS" duct sealing system or Polywater FST series sealant.
- G. At all entrances to panelboards, pull boxes or outlet boxes, conduit runs shall be secured in place with galvanized lock nuts and bushings; one lock nut inside and one lock nut outside the box with the bushing on the inside. Bushings shall be of the insulating throat type. Where conduit fittings are used, a single locknut with insulated throat fitting is acceptable.
- H. Field bends shall be made with standard tools and equipment manufactured specifically for conduit bending. Use factory elbows for bends in conduit larger than 2" trade size. Use conduit bodies to make sharp changes in direction.
- I. Complete the installation of electrical raceways before starting installation of cables within raceways.
- J. Provide flexible conduit for motor connections transformer connections and for other electrical equipment connections where subjected to movement and vibration.
- K. Provide liquid-tight flexible conduit for connection of motors and for other electrical equipment

where subject to movement and vibration, and also where subjected to one or more of the following conditions:

- 1) Exterior location.
 - 2) Moist or humid atmosphere where condensate can be expected to accumulate.
- L. Where possible, install horizontal raceway runs above water piping.
- M. All conduit to be concealed in walls, ceiling or floor, except in the mechanical and electrical rooms where exposed conduit is permitted or where approved by architect.
- N. Exposed conduit shall run parallel or perpendicular to members of the building structure, rigidly maintained and clamped with one-hole malleable iron conduit clamps or conduit supports similar to those of Steel City Electric Company or Unistrut Corporation.
- O. All conduit shall be rigidly and independently supported from the structure at 7'-0" maximum spacing. No conduit shall rest on or be supported from acoustic tile ceiling support wires, ductwork or piping. Support outlet boxes directly from the structure or where not possible, within one (1) foot of box. Provide all miscellaneous steel and support framing for electrical installation.
- P. Locate conduit runs to avoid equipment and items requiring service. Maintain clearance of six (6) inches minimum from water piping and twelve (12) inches minimum from heating system piping.
- Q. All PVC conduits shall have bell ends. Provide expansion fittings at spacing recommended by the manufacturer.
- R. All communications conduits shall have nylon bushings at both ends and pull strings.
- S. All communications conduits shall have wide sweep 90° elbows and pull boxes after two (2) bends.
- T. Penetrations of floor slabs shall be made with rigid galvanized steel conduit. All conduit below floor slabs shall be run in sub-floor below floor, not in floor pour. Provide expansion fitting prior to entry into first box, enclosure or conduit section.
- U. Maintain 12" clearance minimum for all conduits from heat producing equipment, such as flues, heat exchangers.
- V. Conductor Installation: Conductor sizes, type and quantity shall be furnished and installed as required by the drawings and as specified in these specifications.
- 1) All wiring shall be installed in accordance with the applicable provision of the National Electrical Code and as specified herein and shown on the drawings.

- 2) All branch circuit wiring involving a total length over 75' shall use the next largest wire size for the home run and/or the portion exceeding 75'.
 - 3) Pull conductors together where more than one is being installed in a raceway.
 - 4) Use pulling compound or lubricant, when necessary; compound must not deteriorate conductor and insulation.
 - 5) Keep conductor splices to a minimum.
 - 6) Wire shall be installed only after all work that may cause injury is completed, such as the pouring of concrete.
 - 7) Install splices and taps which have equivalent or better mechanical strength and insulation as the conductor.
 - 8) Use splice and tap connectors which are compatible with the conductor material.
- W. Provide seals when conduit is passing from cold to warm environments. Use silicone sealant around boxes and exterior of raceways and sealing system within raceways, Polywater FST or Raychem RDSS Bags.

END OF SECTION

SECTION 262400

SERVICE AND DISTRIBUTION

PART 1 GENERAL

1.01 REFERENCE

- A. Drawings and general provisions of contract including General and Supplementary Conditions and Division 1 specification sections, apply to work of this section.
- B. Division 26, Section 260000, Electrical General Provisions and Section 260500, Basic Materials and Methods, apply to work of this section.

1.02 CONTENTS

- A. Specified herein: Requirements for electrical service and distribution.
- B. Described herein are the following:
 - Scope.
 - Circuit Breaker Panelboards.
 - Grounding.

1.03 SCOPE

- A. The extent of electrical service and distribution work is indicated by drawings and in schedules, in other Division 23 and 26 requirements of this division, and is hereby defined to include, not necessarily limited to:
 - 1) Panelboards.
 - 2) Grounding.

PART 2 PRODUCTS

2.01 PANELBOARDS

- A. General: Except as otherwise indicated, provide panelboards, enclosures and components of types, sizes and ratings indicated, which comply with manufacturer's standard materials, design and construction, in accordance with published product information; equip with number of unit panelboard devices as indicated for a complete installation. Where more than one type of component meets indicated requirements, selection is installer's option. Where types, sizes or ratings are not otherwise indicated, comply with NEC, UL and established industry standards for applications indicated. Panelboard ratings, current and voltage, fused switch or

circuit breaker complement, interrupting ratings and mounting are indicated on the drawings. Where not noted, the minimum interrupting rating on the 480 volt system shall be 14 KAIC and 10 KAIC on the 120 volt system.

- B. Lighting and Power Panelboards: Provide dead-front safety type lighting and power panelboards as indicated, with switching and protective devices in quantities, ratings, types and arrangement shown; with anti-turn solderless pressure type lug connectors approved for copper conductors sized for conductors shown on the one line diagram; construct unit for connecting feeders at top or bottom of panel to suit field conditions; equipped with copper bus bars, full-sized neutral bar, with bolt-in type molded case branch circuit breakers for each circuit, with toggle handles that indicate when tripped. Where multiple-pole breakers are indicated, provide with common trip so overload on one pole will trip all poles simultaneously. Provide a bare uninsulated copper grounding bar suitable for bolting to enclosure.
- C. Circuit breakers with frame sizes 1200 amps and greater shall be installed with energy reducing maintenance switch and status indicator per the NEC.
- D. Panelboard Enclosures: Provide galvanized sheet steel cabinet type enclosures, in sizes and NEMA types as indicated, code-gage, minimum 16-gage thickness. Construct with multiple knockouts and wiring gutters.
- E. Panelboard Fronts: Provide panelboard fronts with door-in-cover feature with a hinged door over the interior and the cover to give access to the wiring gutter. The inner door over the interior shall have flush lock keyed to match other panels.
- F. All panelboard fronts shall be equipped with interior circuit-directory frame and card with clear plastic covering. Provide baked gray enamel finish over a rust inhibitor. Design enclosure for surface or flush mounting, as indicated on the drawings. Provide enclosures fabricated by same manufacturer as panelboards and which fit properly with panelboards to be enclosed.

Panelboard Accessories: Provide panelboard accessories and devices, including but not necessarily limited to, circuit breakers, ground-fault protection breakers, arc fault protection breakers, H.I.D., SWD and HACR rated circuit breakers etc., as recommended by panelboard manufacturer or required by code for ratings and applications indicated.

- G. Panelboards shall be of the same manufacturer and the following shall be acceptable

Circuit Breaker (Panelboards)

Square D "NQOD" with QOB breakers
Eaton "Pow-R-Line" with BAB breakers
Siemens Sentron with "BQ" breakers
ABB "A" Series with THQB breakers

2.02 MATERIALS AND COMPONENTS, GROUNDING

- A. The entire light and power system shall be permanently and effectively grounded in accordance with the latest issue of the National Electrical Code, including panels, motor frames and other exposed non-current carrying electrical parts of the electrical equipment and conductive components of the building structure and mechanical systems (i.e., piping, ductwork, etc.).
- B. Article 250 of the National Electrical Code shall be complied with in its entirety with regard to this installation. Particular attention shall be paid to Article 250-45 in reference to appliance and portable equipment grounding.
- C. Metallic conduit system shall be electrically continuous throughout and be grounded at the service entrance. All conduits and cable assemblies for feeders and branch circuits shall include a green ground wire. Install grounding jumper across all flexible conduit.
- D. A green pigtail shall be installed from grounding slots of all grounding outlets to outlet box in each instance where the receptacle attachment bar is not in direct contact with the outlet box or outlet box plaster plate.

PART 3 EXECUTION

3.01 INSPECTION

- A. Installer must examine areas and conditions under which electrical work is to be installed and notify contractor in writing of conditions detrimental to proper and timely completion of the work. Do not proceed with the work until unsatisfactory conditions have been corrected in a manner acceptable to installer.

3.02 ELECTRICAL INSTALLATIONS

- A. General: Install electrical equipment for this project as indicated, in accordance with the manufacturer's written instructions, the applicable requirements of NEC and the National Electrical Contractors Association's "Standard of Installation" and in accordance with recognized industry functions.
- B. Direct all other contractors to maintain required clearances from electrical equipment to piping and ductwork during construction progress.
- C. All panelboards, switchboards, motor control centers and control panels shall be labeled to warn qualified persons of electric ARC flash hazards per NEC.
- D. Provide 4" minimum height concrete housekeeping pads for all floor mounted electrical distribution equipment including (but not limited to) switchboards, switchgear, distribution panelboards, motor control centers and transformers.

- E. Provide performance testing of service ground fault protection system on site by equipment manufacturer per the NEC.

3.03 PANELBOARDS

- A. Coordinate installation of panelboards and enclosures with cable and raceway installation work.
- B. Anchor enclosures firmly to walls and structural surfaces, ensuring that they are permanently and mechanically secure.
- C. Provide electrical connections within enclosures.
- D. Fill out typed panelboard's circuit directory card upon completion of the work.
- E. The system of branch circuits for power and lighting shall be connected to panel busses in such a manner as to electrically balance the connected loads as close as is practicable.
- F. Panels installed on exterior building walls shall be shimmed 1/4" from wall to permit back ventilation.

3.04 DISTRIBUTION

- A. Provide feeder conduits and wire from main power panel to branch panels and major mechanical equipment.
- B. Conduit and wire shall be as specified in Section 260500.
- C. Provide green identified ground wire sized per Table 250-95 N.E.C. in all feeder conduits.

3.05 INSTALLATION OF ELECTRICAL GROUNDING

- A. General: Install electrical grounding systems (including ground rods and water line tap) where shown, in accordance with applicable portions of National Electrical Code, with National Electrical Contractors Association's "Standard of Installation" and in accordance with recognized industry practices to ensure that electrical grounding complies with requirements and serves intended purposes.
- B. Coordinate with other electrical work, as necessary to interface installation of electrical grounding system with other work.
- C. Install braided type bonding jumpers with ground clamps on water meter piping to electrically bypass water meter.
- D. Install clamp-on connectors only on thoroughly cleaned metal contact surfaces, to ensure

electrical conductivity and circuit integrity.

- E. A green pigtail shall be installed from grounding outlets to outlet box in each instance where the receptacle attachment bar is not in direct contact with the outlet box or outlet box plaster plate.
- F. Green bonding jumper shall be installed in all flexible metallic conduit.
- G. All metal piping systems, ductwork, and steel frames shall be bonded to the electrical system in compliance with the NEC.

END OF SECTION

SECTION 265000

LIGHTING

PART 1 GENERAL

1.01 REFERENCE

- A. Drawings and general provisions of contract, including General and Supplementary Conditions and Division 1 and 23 specification sections, apply to work of this section.
- B. Division 26, Section 260000, Electrical General Provisions, and Section 260500, Basic Materials and Methods, apply to work of this section.

1.02 CONTENTS

- A. Specified herein: Requirements for installation of interior and exterior equipment.
- B. Described herein are the following:

Luminaires.

1.03 SCOPE

- A. The work shall comprise, but is not necessarily limited to the following:
 - 1) Interior incandescent and fluorescent luminaires.
 - 2) Exterior luminaire and poles.
 - 3) Battery operated emergency lighting and exit lights.

PART 2 PRODUCTS

- A. Provide luminaires as indicated on drawings, completely installed, wired and connected in place, tested and left in satisfactory operating condition.
- B. Fixtures shall be complete with all necessary appurtenances, wiring, lamp holders, shade holders, lamps, reflectors, glassware, canopies, wall bases, pendants, etc. All pendants and canopies shall be of the type required for the specific luminaires and shall be of the same manufacturer as the luminaire. Fixtures shall carry U.L. labels. All acrylic lenses on fluorescent fixtures are to be .125" thick minimum.
- C. LED light sources and fixtures shall be tested in compliance with the current version of LM-79

(IESNA Approved Method for the electrical and Photometric Measurement of Solid State Lighting Products) and LM-80 (IESNA Approved Method for Measuring Lumen Maintenance of LED and Lighting Sources).

- 1) LED light sources and driver shall be RoHS compliant with internal components assembled using modular components.
 - 2) Input wattage, voltage and lumen output shall be as specified on the drawings. Values shown are design minimums and must be verified with plans.
 - 3) Drivers shall be dimming type 0 - 10V DC, three wire or DALI as shown on plan. All dimming controls shall be tested with the specified LED package by the manufacturer to ensure proper operation.
- D. Exit sign to be L.E.D. type with diffused lens. Housing to be white with red letters. Arrows to comply with plans. Full field flexibility shall be capable through the use of individual conversion kits. Exit signs shall be complete with self-contained battery backup.
- E. Luminaires shall be as cataloged on the fixture schedule.
- F. Controls:
- 1) Furnish and install a complete low voltage lighting control system as detailed on the drawings.
 - 2) Provide manufacturer's start up, testing and programming of the system. All program assignments shall be reviewed with the owner and programmed prior to final acceptance. Include owner training and complete documentation, including a typed list of all assignments as programmed at the completion of the project.
 - 3) System shall be as manufactured by Hubbell Lighting Controls or equal by Acuity or Wattstopper. Submit complete shop drawings, including wiring diagrams for this project.

PART 3 EXECUTION

3.01 LUMINAIRE AND WIRING

- A. Install luminaires of types indicated, where shown and at indicated heights, in accordance with luminaire manufacturer's written instructions and with recognized industry practices, to ensure that fixtures comply with requirements and serve intended purposes. Comply with NEMA standards and requirements of National Electrical Code pertaining to installation of interior luminaire and with applicable portions of NECA's "Standard of Installation."

- B. Fully coordinate construction detail with ceiling system in which they are installed via: support system dimensions, flanges where required, acoustical tile or pan pattern, etc. Verify ceiling construction and provide all mounting details and construction and accessories for each luminaire and trim to match ceiling system with color as selected by architect. Provide miscellaneous support steel for structure span where required for support of fixtures. All mounting hardware (screws, nuts, bolts, etc.) shall be stainless steel or brass for exterior luminaires.
- C. Wiring to lay-in type fixtures shall be arranged to facilitate relocation of the fixture to the adjacent ceiling tile in any direction.
- D. Clean interior luminaires of dirt and debris upon completion of installation.
- E. Protect installed fixtures from damage during remainder of construction period.
- F. After systems have been installed and lamped, check for proper operation of all fixtures. Tighten any loose components or connections, replace noisy or defective ballasts and make sure all fixtures are in good condition and properly installed.
- G. Check all switching and leave in good condition. The exact locations of all switches are to be verified in the field with door swing and generally be opposite the hinge side of door.
- H. Clean all electrical panels and luminaires of construction dirt and labels upon completion of project.
- I. All lay-in troffer luminaires to be supported from each corner independent of ceiling grid and attached with grid clips.
- J. All recessed down lights are to be supported with T-bar bridges from the grid and not from ceiling tiles alone unless noted otherwise.
- K. Where surface mounted fixtures are installed in exposed construction, coordinate installation with piping and ductwork. Fixtures are to be hung below piping and ductwork. Support from structure, not from duct or pipes.
- L. All surface mounted fixtures are to be mounted tight to wall or ceiling surfaces and any gaps between fixture mounting plate or body are to be filled and finished.

END OF SECTION

SECTION 275119 - SOUND MASKING SYSTEMS

PART 1 - GENERAL

1.1 SUMMARY

A. Section Includes:

1. Networked sound masking systems.

B. Products Installed, but Not Furnished, under This Section:

C. Related Requirements:

1. Section 260533.13 "Conduit for Electrical Systems" specifies raceways installed by this Section.
2. Section 260533.16 "Boxes and Covers for Electrical Systems" specifies boxes installed by this Section.
3. Section 260553 "Identification for Electrical Systems" specifies electrical equipment labels and warning signs installed by this Section.
4. Section 284600 "Fire Detection and Alarm" specify coordination of sound masking systems with emergency alarms and paging.

PART 2 - PRODUCTS

2.1 PERFORMANCE REQUIREMENTS

- A. Regulatory Requirements: Products or components listed and labeled in accordance with NFPA 70, by qualified electrical testing laboratory recognized by authorities having jurisdiction, and marked for intended location and application.

2.2 NETWORKED SOUND MASKING SYSTEMS

- A. Description: Electronic noise generators and associated controls for simultaneously operating multiple loudspeakers throughout facility.

B. UL AZOT - Multi-Room Sound Masking System:

1. Manufacturers: Subject to compliance with requirements, provide products by the following:
 - a. Cambridge Sound
2. Source Limitations: Obtain products from single manufacturer.
3. Listing Criteria:

- a. Audio Equipment: Comply with the following:
 - 1) UL CCN AZOT; including UL 62368-1.
 - 2) Meet all requirements of US National Electrical Code & FCC Part 15. Controllers shall be CE Marked & UL Listed. Provide 5 years warranty.
 4. Standard Features:
 - a. The controller shall consist of all electronics required for operating a sound masking system from a single accessible location. Systems with distributed electronic packages above the ceiling are not acceptable. The Controller shall permit password protected access for control and monitoring via LAN/Browser interface. The Controller shall provide (3) zones and shall be sufficient to generate sound masking, audio control , and audio power for up to 36,000 SF of coverage. The unit shall be capable of time-of-day masking level control; per zone settins shall be available for day/night levels and start times, ramping interval and weekday/weekend settings. Each audio output shall provide (4) non-correlated channels of masking noise to minimize comb filtering..
 5. Other Available Features Required by the Project:
 - a. Loudspeaker Mounting: Ceiling.
 - b. Network Control Panel Mounting: Rack.
 - c. Provide input for connection to supervised fire-alarm N.O. contact that when closed causes network controller to mute sound masking equipment that includes paging, background music, and other audio programming.
- C. Description: Self-contained loudspeaker with electronic noise generator and associated controls.

PART 3 - EXECUTION

3.1 FIELD QUALITY CONTROL OF SOUND MASKING SYSTEMS

- A. Adminstrant for Communications Tests and Inspections:
 1. Owner will engage qualified communications testing and inspecting agency to administer and perform tests and inspections.
- B. Acceptance Testing Preparation:
 1. Pretesting: Tune, align, and adjust system, and pretest components, wiring, and functions to verify compliance with specified material, installation, and performance requirements. Correct deficiencies and retest until satisfactory performance and conditions are achieved.
- C. Field tests and inspections must be witnessed by Owner.

D. Tests and Inspections:

1. Perform manufacturer's recommended tests and inspections.
2. Operational Test: Start system to confirm proper operation. Remove malfunctioning units, replace with new units, and retest. Make initial sound-spectrum and -level adjustments for each zone.
3. Inspection: Verify that units and controls are properly labeled and interconnecting wires and terminals are identified.
4. Masking Sound Power Level Adjustments: Adjust independently for each space to minimum level between 47 and 50 dB(A-weighted) that will provide speech privacy between adjacent workstations while complying with other system requirements.

E. Final Acceptance Testing: Provide a minimum of 10 days' notice of acceptance test performance schedule. Schedule tests after pretesting has been successfully completed.

1. Perform sound masking evaluation tests in accordance with ASTM E1130, with measurements and calculations in accordance with ASA S3.5.
2. Tests and Calibration Conditions: Spaces are to be completely furnished, but unoccupied; lights and HVAC systems must be on; HVAC system testing and balancing are to be completed; and electronic ballasts, lighting relay panels, and low-voltage transformers must be in place.
3. Test Conditions: Complying with ASTM E1130 and calculated in accordance with ASA S3.5.
4. Instrumentation: Use a professional-quality, sound-level meter with octave-band filters and documentation of recent calibration against recognized standards. Comply with ASA S1.4 Part 1.
5. System Tests: Include the following for each system zone:
 - a. Loudspeaker Circuit Impedance Test: Measure impedance at 1000 Hz with amplifier disconnected, using a professional impedance meter or bridge. Locate and correct faults denoted by abnormal readings.
 - b. Ambient Sound-Level Tests: With system off, measure ambient sound level in one-third octave bands. Also measure ambient sound level as a single, wide-band, A-weighted reading.
 - c. System Noise Test: With masking-noise signal on and amplifiers adjusted at a working level 10 dB above ambient sound level, check for hum, buzz, rattle, or other operating deficiencies.
 - d. Spatial Uniformity Test: Measure sound level at locations no greater than **15 ft** on center throughout covered spaces to determine compliance with specified performance level.
 - e. Frequency Response Adjustment and Test: Adjust one-third octave frequency bands and other unit filters to provide response. Adjust to meet requirement of space speech intelligibility and quality of background sound. Comply with ASA S3.2, CTA-426, and ASTM E1110.
6. Adjust level of masking sound that is appropriate for area and overall volume.
7. Walk-Through Test: People in covered spaces cannot discern loudspeaker locations.

- F. Record test observations, readings, and corrective actions. Report test results in accordance with ASTM E1130.
- G. Record final control settings and programming, and final tap setting of loudspeaker-matching transformers. Record final sound-level measurements and observations.
- H. Nonconforming Work:
 - 1. Units will be considered defective if they do not pass tests and inspections.
 - 2. Remove and replace defective units and retest.
- I. Field Quality-Control Reports: Collect, assemble, and submit test and inspection reports.
- J. Manufacturer Services: Engage factory-authorized service representative to support field tests and inspections.
 - 1. Manufacturer's Field Reports for Field Quality-Control Support: Prepare and submit report after each visit by factory-authorized service representative, documenting activities performed at the Project site.

END OF SECTION 275119

SECTION 284600

FIRE DETECTION AND EMERGENCY COMMUNICATION ALARM SYSTEM

PART 1 GENERAL

1.01 REFERENCE

- A. Drawings and general provisions of contract, including General and Supplementary Conditions and Division 1 specification sections apply to work of this section.
- C. Section 210010 - Fire Protection
- D. Division 23 - HVAC
- E. Section 250010 - Temperature Controls and Instrumentation
- F. Division 26, Section 260500, Basic Materials and Methods, applies to work of this section.

1.02 DESCRIPTION

- A. This section of the specification includes the furnishing, installation, connection and testing of the microprocessor controlled, intelligent reporting fire alarm equipment required to form a complete, operative, coordinated system. It shall include, but not be limited to, alarm initiating devices, alarm notification appliances, Fire Alarm Control Panel (FACP), auxiliary control devices, annunciators, and wiring as shown on the drawings and specified herein.
- B. The fire alarm system shall comply with requirements of NFPA Standard 72 for Protected Premises Signaling Systems and Emergency Communication System (ECS), except as modified and supplemented by this specification. The system shall be electrically supervised and monitor the integrity of all conductors.
- C. The fire alarm system shall be manufactured by an ISO 9001 certified company and meet the requirements of BS EN9001: ANSI/ASQC Q9001-1994.
- D. The FACP and peripheral devices shall be manufactured 100% by a single U.S. manufacturer (or division thereof).
- E. The system and its components shall be Underwriters Laboratories, Inc. listed under the appropriate UL testing standard as listed herein for fire alarm applications and the installation shall be in compliance with the UL listing.
- F. The installing company shall employ NICET (minimum Level II Fire Alarm Technology) technicians on site to guide the final checkout and to ensure the systems integrity.

- G. Systems shall be as specified herein. Base manufacturer shall be Notifier. Equivalent systems by EST, FCI, Simplex or Silent Knight may be bid.

1.03 SCOPE

- A. A new intelligent reporting, microprocessor controlled fire detection system shall be installed in accordance to the project specifications and drawings.

- B. Basic Performance:

- 1) Alarm, trouble and supervisory signals from all intelligent reporting devices shall be encoded on NFPA Style 4 (Class B) Signaling Line Circuits (SLC).
- 2) Initiation Device Circuits (IDC) shall be wired Class B as part of an addressable device connected by the SLC Circuit.
- 3) Notification Appliance Circuits (NAC) shall be wired Class B as part of an addressable device connected by the SLC Circuit.
- 4) On Style 6 or 7 (Class A) configurations a single ground fault or open circuit on the system Signaling Line Circuit shall not cause system malfunction, loss of operating power or the ability to report an alarm.
- 5) Alarm signals arriving at the FACP shall not be lost following a primary power failure (or outage) until the alarm signal is processed and recorded.
- 6) NAC speaker circuits shall be arranged such that there is a minimum of one speaker circuit per floor of the building or smoke zone whichever is greater.
- 7) Audio amplifiers and tone generating equipment shall be electrically supervised for normal and abnormal conditions.
- 8) NAC speaker circuits and control equipment shall be arranged such that loss of any one (1) speaker circuit will not cause the loss of any other speaker circuit in the system.
- 9) Two-way telephone communication circuits shall be supervised for open and short circuit conditions.
- 10) All other functions as required on the drawings.

- C. BASIC SYSTEM FUNCTIONAL OPERATION

When a fire alarm condition is detected and reported by one of the system initiating devices, the following functions shall immediately occur:

- 1) The system alarm LED on the system display shall flash.
- 2) A local piezo electric signal in the control panel shall sound.
- 3) A backlit LCD display shall indicate all information associated with the fire alarm condition, including the type of alarm point and its location within the protected premises.
- 4) Printing and history storage equipment shall log the information associated each new fire alarm control panel condition, along with time and date of occurrence.

- 5) All system output programs assigned via control-by-event interlock programming to be activated by the particular point in alarm shall be executed, and the associated system outputs (notification appliances and/or relays) shall be activated.
- 6) For detection devices in resident rooms or suites, the device shall activate a local audible (and visual in ADA suites where noted) alarm and indicate a supervisory condition on the FACP, annunciator and Guard Shack. In suites with multiple detectors, all detectors shall indicate locally. If another device goes into alarm prior to the system supervisory condition being acknowledged, the full building will go into an alarm condition.

1.04 SUBMITTALS

A. General:

- 1) Submittals shall be submitted to the architect/engineer for review as required in Division 1.
- 2) All references to manufacturer's model numbers and other pertinent information herein is intended to establish minimum standards of performance, function and quality. Equivalent compatible UL-listed equipment from other manufacturers may be substituted for the specified equipment as long as the minimum standards are met.
- 3) For equipment other than that specified, the contractor shall supply proof that such substitute equipment equals or exceeds the features, functions, performance, and quality of the specified equipment.
- 4) Include all submittals to the authority having jurisdiction to obtain installation permits, including NICET IV certified drawings, cut sheets, battery calculations, voltage drop calculations, etc. Pay all costs for permit fees.

B. Shop Drawings:

- 1) Sufficient information, clearly presented, shall be included to determine compliance with drawings and specifications.
- 2) Include manufacturer's name(s), model numbers, ratings, power requirements, equipment layout, device arrangement, complete wiring point-to-point diagrams, and conduit layouts.
- 3) Show annunciator layout, configurations, and terminations.
- 4) Include custom riser diagrams, custom floor plans and manufacturer's specification sheets.

C. Manuals:

- 1) Submit simultaneously with the shop drawings, complete operating and maintenance manuals listing the manufacturer's name(s), including technical data sheets.

- 2) Wiring diagrams shall indicate internal wiring for each device and the interconnections between the items of equipment.
- 3) Provide a clear and concise description of operation that gives, in detail, the information required to properly operate the equipment and system.

D. Software Modifications:

- 1) Provide the services of a factory trained and authorized technician to perform all system software modifications, upgrades or changes. Response time of the technician to the site shall not exceed 4 hours.
- 2) Provide all hardware, software, programming tools and documentation necessary to modify the fire alarm system on site. Modification includes addition and deletion of devices, circuits, zones and changes to system operation and custom label changes for devices or zones. The system structure and software shall place no limit on the type or extent of software modifications on-site.

E. Certifications:

Together with the shop drawing submittal, submit a certification from the major equipment manufacturer indicating that the proposed performer of contract maintenance is an authorized representative of the major equipment manufacturer. Include names and addresses in the certification.

1.05 GUARANTY

All work performed and all material and equipment furnished under this contract shall be free from defects and shall remain so for a period of at least one (1) year from the date of acceptance. The full cost of maintenance, labor and materials required to correct any defect during this one-year period shall be included in the submittal bid.

1.06 POST CONTRACT MAINTENANCE

- A. Complete maintenance and repair service for the fire alarm system shall be available from a factory trained authorized representative of the manufacturer of the major equipment for a period of five (5) years after expiration of the guaranty.
- B. As part of the bid/proposal, include a quote for a maintenance contract to provide all maintenance, tests, and repairs described below. Include also a quote for unscheduled maintenance/repairs, including hourly rates for technicians trained on this equipment, and response travel costs for each year of the maintenance period. Submittals that do not identify all post contract maintenance costs will not be accepted. Rates and costs shall be valid for the period of five (5) years after expiration of the guaranty.

- C. Maintenance and testing shall be on a semiannual basis or as required by the AHJ. A preventive maintenance schedule shall be provided by the contractor describing the protocol for preventive maintenance. The schedule shall include:
- 1) Systematic examination, adjustment and cleaning of all detectors, manual fire alarm stations, control panels, power supplies, relays, waterflow switches and all accessories of the fire alarm system.
 - 2) Each circuit in the fire alarm system shall be tested semiannually.
 - 3) Each smoke detector shall be tested in accordance with the requirements of NFPA 72 Chapter 7.

1.07 APPLICABLE STANDARDS AND SPECIFICATIONS

The specifications and standards listed below form a part of this specification. The system shall fully comply with the latest issue of these standards, if applicable.

A. National Fire Protection Association (NFPA) - USA:

No. 13	Sprinkler Systems
No. 70	National Electrical Code (NEC 2017)
No. 72	National Fire Alarm Code
No. 101	Life Safety Code

B. Underwriters Laboratories Inc. (UL) - USA:

No. 268	Smoke Detectors for Fire Protective Signaling Systems
No. 864	Control Units for Fire Protective Signaling Systems
No. 268A	Smoke Detectors for Duct Applications
No. 521	Heat Detectors for Fire Protective Signaling Systems
No. 464	Audible Signaling Appliances
No. 38	Manually Actuated Signaling Boxes
No. 346	Waterflow Indicators for Fire Protective Signaling Systems
No. 1971	Visual Notification Appliances

C. Local and State Building Codes.

D. All requirements of the Authority Having Jurisdiction (AHJ).

1.08 APPROVALS

- A. The system shall have proper listing and/or approval from the following nationally recognized agencies:

UL	Underwriters Laboratories Inc
ULC	Underwriters Laboratories Canada

- B. The fire alarm control panel shall meet UL Standard 864 (Control Units).

PART 2 PRODUCTS

2.01 EQUIPMENT AND MATERIAL, GENERAL:

- A. All equipment and components shall be new, and the manufacturer's current model. The materials, appliances, equipment and devices shall be tested and listed by a nationally recognized approvals agency for use as part of a protective signaling system, meeting the National Fire Alarm Code.
- B. All equipment and components shall be installed in strict compliance with manufacturers' recommendations. Consult the manufacturer's installation manuals for all wiring diagrams, schematics, physical equipment sizes, etc., before beginning system installation.
- C. All equipment shall be attached to walls and ceiling/floor assemblies and shall be held firmly in place (e.g., detectors shall not be supported solely by suspended ceilings). Fasteners and supports shall be adequate to support the required load.

2.02 CONDUIT AND WIRE

A. Conduit:

- 1) Conduit shall be in accordance with The National Electrical Code (NEC), local and state requirements and Section 26 05 00 of this specification.
- 2) Where required, all wiring shall be installed in conduit or raceway. Conduit fill shall not exceed 40 percent of interior cross sectional area where three or more cables are contained within a single conduit.
- 3) Cable must be separated from any open conductors of power, or Class 1 circuits, and shall not be placed in any conduit, junction box or raceway containing these conductors, per NEC Article 760-55.
- 4) Wiring for 24 volt DC control, alarm notification, emergency communication and similar power-limited auxiliary functions may be run in the same conduit as initiating and signaling line circuits. All circuits shall be provided with transient suppression devices and the system shall be designed to permit simultaneous operation of all circuits without interference or loss of signals.
- 5) Conduit shall not enter the fire alarm control panel, or any other remotely mounted control panel equipment or backboxes, except where conduit entry is specified by the FACP manufacturer.
- 6) Conduit shall be 3/4-inch (19.1 mm) minimum.

B. Wire:

- 1) All fire alarm system wiring shall be new.

- 2) Wiring shall be in accordance with local, state and national codes (e.g., NEC Article 760) and as recommended by the manufacturer of the fire alarm system. Number and size of conductors shall be as recommended by the fire alarm system manufacturer, but not less than 18 AWG (1.02 mm) for Initiating Device Circuits and Signaling Line Circuits, and 14 AWG (1.63 mm) for Notification Appliance Circuits.
- 3) All wire and cable shall be listed and/or approved by a recognized testing agency for use with a protective signaling system.
- 4) Wire and cable not installed in conduit shall have a fire resistance rating suitable for the installation as indicated in NFPA 70 (e.g., FPLR). Route in spaces approved for this wiring by the architect. Coordinate closely with all trades.
- 5) Wiring used for the multiplex communication circuit (SLC) shall be twisted and unshielded and support a minimum wiring distance of 12,500 feet. The design of the system shall permit use of IDC and NAC wiring in the same conduit with the SLC communication circuit.
- 6) All field wiring shall be electrically supervised for open circuit and ground fault.
- 7) The fire alarm control panel shall be capable of t-tapping Class B (NFPA Style 4) Signaling Line Circuits (SLCs). Systems that do not allow or have restrictions in, for example, the amount of t-taps, length of t-taps etc., are not acceptable.

C. Terminal Boxes, Junction Boxes and Cabinets:

All boxes and cabinets shall be UL listed for their use and purpose.

D. Initiating circuits shall be arranged to serve like categories (manual, smoke, waterflow). Mixed category circuitry shall not be permitted except on signaling line circuits connected to intelligent reporting devices.

E. The fire alarm control panel shall be connected to a separate dedicated branch circuit, maximum 20 amperes. This circuit shall be labeled at the main power distribution panel as FIRE ALARM. Fire alarm control panel primary power wiring shall be 12 AWG. The control panel cabinet shall be grounded securely to the building grounding electrode system.

F. Provide all cutting and patching of existing construction, fire stopping conduit sleeves, etc., for a complete installation.

2.03 MAIN FIRE ALARM CONTROL PANEL OR NETWORK NODE

A. Main FACP or network node shall be a NOTIFIER Model NFS2-640 and shall contain a microprocessor based Central Processing Unit (CPU) and power supply in an economical space saving single board design. The CPU shall communicate with and control the following types of equipment used to make up the system: intelligent addressable smoke and thermal (heat) detectors, addressable modules, printer, annunciators, and other system controlled devices.

B. Operator Control

- 1) Acknowledge Switch:
 - a. Activation of the control panel acknowledge switch in response to new alarms and/or troubles shall silence the local panel piezo electric signal and change the alarm and trouble LEDs from flashing mode to steady-ON mode. If multiple alarm or trouble conditions exist, depression of this switch shall advance the LCD display to the next alarm or trouble condition.
 - b. Depression of the Acknowledge switch shall also silence all remote annunciator piezo sounders.
- 2) Alarm Silence Switch:

Activation of the alarm silence switch shall cause all programmed alarm notification appliances and relays to return to the normal condition after an alarm condition. The selection of notification circuits and relays that are silenceable by this switch shall be fully field programmable within the confines of all applicable standards. The FACP software shall include silence inhibit and auto-silence timers.
- 3) Alarm Activate (Drill) Switch:

The Alarm Activate switch shall activate all notification appliance circuits. The drill function shall latch until the panel is silenced or reset.
- 4) System Reset Switch:

Activation of the System Reset switch shall cause all electronically-latched initiating devices, appliances or software zones, as well as all associated output devices and circuits, to return to their normal condition.
- 5) Lamp Test:

The Lamp Test switch shall activate all local system LEDs, light each segment of the liquid crystal display and display the panel software revision for service personal

C. System Capacity and General Operation

- 1) The control panel or each network node shall provide, or be capable of expansion to 636 intelligent/addressable devices.
- 2) The control panel or each network node shall include Form-C alarm, trouble, supervisory, and security relays rated at a minimum of 2.0 amps @ 30 VDC.
- 3) It shall also include four Class B (NFPA Style Y) or Class A (NFPA Style Z) programmable Notification Appliance Circuits
- 4) The Notification Appliance Circuits shall be programmable to Synchronize with System Sensor, Gentex and Wheelock Notification Appliances.
- 5) The system shall include a full featured operator interface control and annunciation panel that shall include a backlit Liquid Crystal Display (LCD), individual color coded system status LEDs, and an alphanumeric keypad with easy touch rubber keys for the field programming and control of the fire alarm system.
- 6) The system shall be programmable, configurable, and expandable in the field without the need for special tools, PROM programmers or PC based programmers. It shall not require replacement of memory ICs to facilitate programming changes.

- 7) The system shall allow the programming of any input to activate any output or group of outputs. Systems that have limited programming (such as general alarm), have complicated programming (such as a diode matrix), or require a laptop personal computer are not considered suitable substitutes.
The FACP shall support up to 20 logic equations, including "and," "or," and "not," or time delay equations to be used for advanced programming. Logic equations shall require the use of a PC with a software utility designed for programming.
- 8) The FACP or each network node shall provide the following features:
 - a. Drift compensation to extend detector accuracy over life. Drift compensation shall also include a smoothing feature, allowing transient noise signals to be filtered out.
 - b. Detector sensitivity test, meeting requirements of NFPA 72, Chapter 7.
 - c. Maintenance alert, with two levels (maintenance alert/maintenance urgent), to warn of excessive smoke detector dirt or dust accumulation.
 - d. Nine sensitivity levels for alarm, selected by detector. The alarm level range shall be .5 to 2.35 percent per foot for photoelectric detectors and 0.5 to 2.5 percent per foot for ionization detectors. The system shall also support sensitive advanced detection laser detectors with an alarm level range of .03 percent per foot to 1.0 percent per foot. The system shall also include up to nine levels of Prealarm, selected by detector, to indicate impending alarms to maintenance personnel.
 - e. The ability to display or print system reports.
 - f. Alarm verification, with counters and a trouble indication to alert maintenance personnel when a detector enters verification 20 times.
 - g. PAS presignal, meeting NFPA 72 3-8.3 requirements.
 - h. Rapid manual station reporting (under 3 seconds) and shall meet NFPA 72 Chapter 1 requirements for activation of notification circuits within 10 seconds of initiating device activation.
 - i. Periodic detector test, conducted automatically by the software.
 - j. Self-optimizing pre-alarm for advanced fire warning, which allows each detector to learn its particular environment and set its prealarm level to just above normal peaks.
 - k. Cross zoning with the capability of counting: two detectors in alarm, two software zones in alarm, or one smoke detector and one thermal detector.
 - l. Walk test, with a check for two detectors set to same address.
 - m. Control-by-time for non-fire operations, with holiday schedules.
 - n. Day/night automatic adjustment of detector sensitivity.
 - o. Device blink control for sleeping areas.
- 9) The FACP shall be capable of coding main panel node notification circuits in March Time (120 PPM), Temporal (NFPA 72 A-2-2.2.2). Panel notification circuits (NAC 1,2, 3 and 4) shall also support Two-Stage operation. Two stage operation shall allow 20 Pulses Per Minute (PPM) on alarm and 120 PPM after 5 minutes or when a

second device activates. The panel shall also provide a coding option that will synchronize specific strobe lights designed to accept a specific "sync pulse."

D. Central Microprocessor

- 1) The microprocessor shall be a state-of-the-art, high speed, 16-bit RISC device and it shall communicate with, monitor and control all external interfaces. It shall include an EPROM for system program storage, Flash memory for building-specific program storage, and a "watch dog" timer circuit to detect and report microprocessor failure.
- 2) The microprocessor shall contain and execute all control-by-event programs for specific action to be taken if an alarm condition is detected by the system. Control-by-event equations shall be held in non-volatile programmable memory, and shall not be lost even if system primary and secondary power failure occurs.
- 3) The microprocessor shall also provide a real-time clock for time annotation of system displays, printer, and history file. The time-of-day and date shall not be lost if system primary and secondary power supplies fail. The real time clock may also be used to control non-fire functions at programmed time-of-day, day-of-week, and day-of-year.
- 4) A special program check function shall be provided to detect common operator errors.
- 5) An auto-program (self-learn) function shall be provided to quickly install initial functions and make the system operational.
- 6) For flexibility and to ensure program validity, an optional Windows(TM) based program utility shall be available. This program shall be used to off-line program the system with batch upload/download, and have the ability to upgrade the manufacturers (FLASH) system code changes. This program shall also have a verification utility, which scans the program files, identifying possible errors. It shall also have the ability to compare old program files to new ones, identifying differences in the two files to allow complete testing of any system operating changes. This shall be in compliance with the NFPA 72 requirements for testing after system modification.

E. System Display

- 1) The system shall support the following display mode options:
 - a. The CPU with no display option shall allow the fire alarm control panel to function as a data-gathering panel when the panel is connected to a network with a Network Control Station (NCS) or Network Control Annunciator (NCA). In this application, the NCS or NCA shall provide all of the necessary controls and indicators to be used by the system operator. Programming of the CPU may be accomplished from the NCS or by use of a laptop PC with the software programming utility connected directly to the CPU.

- b. 80 character display option. The display shall include an 80-character backlit alphanumeric Liquid Crystal Display (LCD) and a full PC style QWERTY keypad.
 - c. 640-character display option. The design of the CPU shall provide for a configuration with the 640 Character display mounted on the front of the CPU in place of the standard 80-character display.
- 2) The display shall provide all the controls and indicators used by the system operator:
- a. The 80-character display shall include the following operator control switches: ACKNOWLEDGE, ALARM SILENCE, ALARM ACTIVATE (drill), SYSTEM RESET, and LAMP TEST.
 - b. The 640-character display shall include the following operator control switches: ACKNOWLEDGE, ALARM SILENCE, ALARM ACTIVATE (drill), SYSTEM RESET, and LAMP TEST.
- 3) The display shall annunciate status information and custom alphanumeric labels for all intelligent detectors, addressable modules, internal panel circuits, and software zones.
- 4) The display shall also provide Light-Emitting Diodes.
- a. The 80-character display shall provide 12 Light-Emitting-Diodes (LEDs), that indicate the status of the following system parameters: AC POWER, FIRE ALARM, PREALARM WARNING, SECURITY ALARM, SUPERVISORY SIGNAL, SYSTEM TROUBLE, DISABLED POINTS, ALARM SILENCED, Controls Active, Pre-Discharge, Discharge and Abort.
- 5) The 640-character display shall provide 11 Light-Emitting-Diodes (LEDs), that indicate the status of the following system parameters: AC POWER, FIRE ALARM, PREALARM WARNING, SECURITY ALARM, SUPERVISORY EVENT, SYSTEM TROUBLE, ALARM SILENCED, DISABLED POINTS, OTHER EVENTS, CPU FAILURE and Controls Active.
- 6) The display shall have QWERTY type keypad.
- a. The 80-character display keypad shall be an easy to use QWERTY type keypad, similar to a PC keyboard. This shall be part of the standard system and have the capability to command all system functions, entry of any alphabetic or numeric information, and field programming. Two different password levels shall be provided to prevent unauthorized system control or programming.
 - b. The 640-character display shall use 10 "soft" keys for screen navigation or to accomplish dedicated programming functions. Full programming access shall require use of a laptop and the proper programming utility.

- 7) The system shall support the display of battery charging current and voltage on the 80-character LCD display.

F. Signaling Line Circuits (SLC)

- 1) Each FACP or FACP network node shall support up to two SLCs. Each SLC interface shall provide power to and communicate with up to 159 intelligent detectors (ionization, photoelectric or thermal) and 159 intelligent modules (monitor or control) for a loop capacity of 318 devices. The addition of the optional second loop shall double the device capacity, supporting a total of 636 devices. Each SLC shall be capable of NFPA 72 Style 4, Style 6, or Style 7 (Class A or B) wiring.
- 2) CPU shall receive analog information from all intelligent detectors to be processed to determine whether normal, alarm, prealarm, or trouble conditions exist for each detector. The software shall automatically maintain the detector's desired sensitivity level by adjusting for the effects of environmental factors, including the accumulation of dust in each detector. The analog information shall also be used for automatic detector testing and for the automatic determination of detector maintenance requirements.

G. Serial Interfaces

- 1) The system shall include two serial EIA-232 interfaces. Each interface shall be a means of connecting UL Listed Information Technology Equipment (ITE) peripherals.
 - a. One EIA-232 interface shall be used to connect an UL-Listed 40 or 80 column printer. Printers that are not UL-Listed are not considered acceptable substitutes.
 - b. One EIA-232 interface shall be used to connect an UL-Listed 40 or 80 column printer. Printers that are not UL-Listed are not considered acceptable substitutes.
 - c. One EIA-232 interface shall be used to connect a UL-listed CRT terminal. This interface shall include special protocol methods that allow off-site monitoring of the FACP over standard dial-up phone lines. This ancillary capability shall allow remote readout of all status information, including analog values, and shall not interfere with or degrade FACP operations when used. It shall allow remote FACP Acknowledge, Reset, or Signal Silence in this mode. It shall also allow adjustment of detector sensitivity and readout of the history file.
 - d. The system shall include an EIA-485 port for the serial connection of optional annunciators and remote LCD displays.
 - e. The EIA-485 interface may be used for network connection to a proprietary-receiving unit.

H. Voice Command Center (VCC)

- 1) The facility shall have an emergency voice alarm communication system. Digitally stored message sequences shall notify the building occupants that a fire or life safety condition has been reported. A Message generator shall be capable of automatically distributing up to four (4) simultaneous, unique messages to appropriate audio zones within the facility based on the type and location of the initiating event. The Fire Command Center (FCC) shall also support Emergency manual voice announcement capability for both system wide or selected audio zones, and shall include provisions for the system operator to override automatic messages system wide or in selected zones.
 - a. The digital audio message generator shall be of reliable, non-moving parts, and support the digital storage of at least 16 or 32 minutes of tones and emergency messages, shall support programming options to string audio segments together to create up to 1000 messages, or to loop messages and parts of messages to repeat for pre-determined cycles or indefinitely.
 - b. The audio portion of the system shall sound the proper audio signal (consisting of tone, voice, or tone and voice) to the appropriate zones.
 - c. Notification Appliance Circuits (NAC) speaker circuits shall be arranged such that there is a minimum of one speaker circuit per floor of the building or smoke zone whichever is greater.
 - d. Audio amplifiers and tone generating equipment shall be electrically supervised for normal and abnormal conditions.
 - e. Speaker circuits shall be electrically supervised for open and short circuit conditions. If a short circuit exists on a speaker circuit, it shall not be possible to activate that circuit.
 - f. Speaker circuits shall be either 25 VRMS or 70VRMS. Speaker circuits shall have 20% spare capacity for future expansion or increased power output requirements.
 - g. All visual appliance circuits shall have 10% spare capacity for future strobes.
 - h. The emergency communication system shall have provision for audio input from the owner's systems to allow audio input via local microphone and standard signal level audio input.

I. Enclosures:

- 1) The control panel shall be housed in a UL-listed cabinet suitable for surface or semi-flush mounting. The cabinet and front shall be corrosion protected, given a rust-resistant prime coat, and manufacturer's standard finish.
- 2) The back box and door shall be constructed of 0.060 steel with provisions for electrical conduit connections into the sides and top.
- 3) The door shall provide a key lock and shall include a glass or other transparent opening for viewing of all indicators. For convenience, the door may be site configured for either right or left hand hinging.

J. Power Supply:

- 1) A high tech off-line switching power supply shall be available for the fire alarm control panel or network node and provide 6.0 amps of available power for the control panel and peripheral devices.
- 2) Provisions will be made to allow the audio-visual power to be increased as required by adding modular expansion audio-visual power supplies.
- 3) Positive-Temperature-Coefficient (PTC) thermistors, circuit breakers, or other over-current protection shall be provided on all power outputs. The power supply shall provide an integral battery charger for use with batteries up to 55 AH or may be used with an external battery and charger system. Battery arrangement may be configured in the field.
- 4) The power supply shall continuously monitor all field wires for earth ground conditions, and shall have the following LED indicators:
 - Ground Fault LED
 - AC Power Fail LED
 - NAC on LED (4)
- 5) The main power supply shall operate on 120 VAC, 60 Hz, and shall provide all necessary power for the FACP.
- 6) The main power supply shall provide a battery charger using dual-rate charging techniques for fast battery recharge and be capable of charging batteries up to 200 AH.
- 7) All circuits shall be power-limited, per UL864 requirements.

K. Auxiliary Field Power Supply - Addressable

- 1) The auxiliary addressable power supply is a remote 24 VDC power supply used to power Notification Devices and field devices that require regulated 24VDC power. The power supply shall also include and charge backup batteries.
- 2) The addressable power supply for the fire alarm system shall provide up a minimum of 6.0 amps of 24 volt DC regulated power for Notification Appliance Circuit (NAC) power or 5 amps of 24 volt DC general power. The power supply shall have an additional .5 amp of 24 VDC auxiliary power for use within the same cabinet as the power supply. It shall include an integral charger designed to charge 7.0 - 25.0 amp hour batteries.
- 3) The addressable power supply shall provide four individually addressable Notification Appliance Circuits that may be configured as two Class "A" and two Class "B" or four Class "B" only circuits. All circuits shall be power-limited per UL 864 requirements.
- 4) The addressable power supply shall provide built-in synchronization for certain Notification Appliances on each circuit without the need for additional synchronization modules. The power supply's output circuits shall be individually selected for synchronization. A single addressable power supply shall be capable of supporting both synchronized and non-synchronized Notification Devices at the same time.

- 5) The addressable power supply shall operate on 120 or 240 VAC, 50/60 Hz.
- 6) The interface to the power supply from the Fire Alarm Control Panel (FACP) shall be via the Signaling Line Circuit (SLC) or other multiplexed means. Power supplies that do not use an intelligent interface are not suitable substitutes. The required wiring from the FACP to the addressable power supply shall be a single unshielded twisted pair wire. Data on the SLC shall be transmitted between 24 VDC, 5 VDC and 0 VDC at approximately 3.33k baud.
- 7) The addressable power supply shall supervise for battery charging failure, AC power loss, power brownout, battery failure, NAC loss, and optional ground fault detection. In the event of a trouble condition, the addressable power supply shall report the incident and the applicable address to the FACP via the SLC.
- 8) The addressable power supply shall have an AC Power Loss Delay option. If this option is utilized and the addressable power supply experiences an AC power loss, reporting of the incident to the FACP will be delayed. A delay time of eight or sixteen hours shall be Dip-switch selected.
- 9) The addressable power supply shall have an option for Canadian Trouble Reporting and this option shall be Dip-switch selectable.
- 10) The addressable power supply mounts in either the FACP backbox or its own dedicated surface mounted backbox with cover.
- 11) Each of the power supply's four output circuits shall be DIP-switch selected for Notification Appliance Circuit or General Purpose 24 VDC power. Any output circuit shall be able to provide up to 2.5 amps of 24 VDC power.
- 12) The addressable power supply's output circuits shall be individually supervised when they are selected to be either a Notification Appliance Circuit when wired Class "A" or by the use of an end-of-line resistor. When the power supply's output circuit is selected as General 24VDC power, the circuit shall be individually supervised when an end-of-line relay is used.
- 13) When selected for Notification Appliance Circuits, the output circuits shall be individually DIP-switch selectable for Steady, March Time, Dual Stage or Temporal.
- 14) When selected as a Notification Appliance Circuit, the output circuits of the addressable power supply shall have the option to be coded by the use of a universal zone coder.
- 15) The addressable power supply shall interface and synchronize with other power supplies of the same type. The required wiring to interface multiple addressable power supplies shall be a single unshielded, twisted pair wire.
- 16) An individual or multiple interfaced addressable power supplies shall have the option to use an external charger for battery charging. Interfaced power supplies shall have the option to share backup battery power.

L. Field Charging Power Supply (FCPS)

The FCPS is a device designed for use as either a remote 24 volt power supply or used to power Notification Appliances.

- 1) The FCPS shall offer up to 6.0 amps (4.0 amps continuous) of regulated 24 volt power. It shall include an integral charger designed to charge 7.0 amp hour batteries and to support 60 hour standby.
- 2) The Field Charging Power Supply shall have two input triggers. The input trigger shall be a Notification Appliance Circuit (from the fire alarm control panel) or a relay. Four outputs (two Style Y or Z and two style Y) shall be available for connection to the Notification devices.
- 3) The FCPS shall include an attractive surface mount backbox.
- 4) The Field Charging Power Supply shall include the ability to delay the AC fail delay per NFPA requirements.
- 5) The FCPS include power limited circuitry, per 1995 UL standards.

M. Specific System Operations

- 1) Smoke Detector Sensitivity Adjust: A means shall be provided for adjusting the sensitivity of any or all addressable intelligent detectors in the system from the system keypad. Sensitivity range shall be within the allowed UL window and have a minimum of 9 levels.
- 2) Alarm Verification: Each of the intelligent addressable smoke detectors in the system may be independently selected and enabled to be an alarm verified detector. The alarm verification delay shall be programmable from 5 to 30 seconds and each detector shall be able to be selected for verification. The FACP shall keep a count of the number of times that each detector has entered the verification cycle. These counters may be displayed and reset by the proper operator commands.
- 3) Point Disable: Any addressable device or conventional circuit in the system may be enabled or disabled through the system keypad.
- 4) Point Read: The system shall be able to display or print the following point status diagnostic functions:
 - a. Device status
 - b. Device type
 - c. Custom device label
 - d. View analog detector values
 - e. Device zone assignments
 - f. All program parameters
- 5) System Status Reports: Upon command from an operator of the system, a status report will be generated and printed, listing all system status.
- 6) System History Recording and Reporting: The fire alarm control panel shall contain a history buffer that will be capable of storing up to 800 events. Up to 200 events shall be dedicated to alarm and the remaining events are general purpose. Systems that do not have dedicated alarm storage, where events are overridden by non-alarm type events, are not suitable substitutes. Each of these activations will be stored and time and date stamped with the actual time of the activation. The contents of the history buffer may be manually reviewed, one event at a time, or

printed in its entirety. The history buffer shall use non-volatile memory. Systems that use volatile memory for history storage are not acceptable substitutes.

- 7) Automatic Detector Maintenance Alert: The fire alarm control panel shall automatically interrogate each intelligent detector and shall analyze the detector responses over a period of time. If any intelligent detector in the system responds with a reading that is above or below normal limits, then the system will enter the trouble mode, and the particular detector will be annunciated on the system display, and printed on the optional printer. This feature shall in no way inhibit the receipt of alarm conditions in the system, nor shall it require any special hardware, special tools or computer expertise to perform.
- 8) Pre-Alarm Function: The system shall provide two levels of pre-alarm warning to give advance notice of a possible fire situation. Both pre-alarm levels shall be fully field adjustable. The first level shall give an audible indication at the panel. The second level shall give an audible indication and may also activate control relays. The system shall also have the ability to activate local detector sounder bases at the pre-alarm level, to assist in avoiding nuisance alarms.
- 9) Software Zones: The FACP shall provide 100 software zones, 10 additional special function zones, 10 releasing zones, and 20 logic zones.
- 10) The fire alarm control panel shall include a walk test feature. It shall include the ability to test initiating device circuits and notification appliance circuits from the field without returning to the panel to reset the system. Operation shall be as follows:
 - a. Alarming an initiating device shall activate programmed outputs, which are selected to participate in walk test, for 3 seconds.
 - b. Introducing a trouble into the initiating device shall activate the programmed outputs for 8 seconds.
 - c. All devices tested in walk test shall be recorded in the history buffer.
- 11) Waterflow Operation
An alarm from a waterflow detection device shall activate the appropriate alarm message on the main panel display, turn on all programmed notification appliance circuits and shall not be affected by the signal silence switch.
- 12) Supervisory Operation
An alarm from a supervisory device shall cause the appropriate indication on the system display, light a common supervisory LED, but will not cause the system to enter the trouble mode.
- 13) Signal Silence Operation
The FACP shall have the ability to program each output circuit (notification, relay, speaker etc.) to deactivate upon depression of the signal silence switch.
- 14) Non-Alarm Input Operation
Any addressable initiating device in the system may be used as a non-alarm input to monitor normally open contact type devices. Non-alarm functions are a lower priority than fire alarm initiating devices.
- 15) Combo Zone

A special type code shall be available to allow waterflow and supervisory devices to share a common addressable module. Waterflow devices shall be wired in parallel, supervisory devices in series.

2.04 SYSTEM COMPONENTS

A. Programmable Electronic Sounders:

- 1) Electronic sounders shall operate on 24 VDC nominal.
- 2) Electronic sounders shall be field programmable without the use of special tools, at a sound level of at least 90 dBA measured at 10 feet from the device.
- 3) Shall be flush or surface mounted as shown on plans.

B. Speakers:

- 1) All speakers shall operate on 25 VRMS or with field selectable output taps from 0.5 to 2.0 Watts.
- 2) Speakers in corridors and public spaces shall produce a nominal sound output of 84 dBA at 10 feet (3m).
- 3) Frequency response shall be a minimum of 400 HZ to 4000 HZ.
- 4) The back of each speaker shall be sealed to protect the speaker cone from damage and dust.

C. Strobe lights shall meet the requirements of the ADA, UL Standard 1971, be fully synchronized, and shall meet the following criteria:

- 1) The maximum pulse duration shall be 2/10 of one second.
- 2) Strobe intensity shall meet the requirements of UL 1971.
- 3) The flash rate shall meet the requirements of UL 1971.
- 4) Strobe light intensities shall be adjustable for 15 cd to 110 cd in field by means of dip switches. Housing shall be red or white as specified by architect.

D. Manual Fire Alarm Stations

- 1) Manual fire alarm stations shall be non-code, non-breakglass type, equipped with key lock so that they may be tested without operating the handle.
- 2) Stations must be designed such that after an actual activation, they cannot be restored to normal except by key reset.
- 3) An operated station shall automatically condition itself so as to be visually detected, as operated, at a minimum distance of 100 feet (30.5 m) front or side.
- 4) Manual stations shall be constructed of high impact Lexan, with operating instructions provided on the cover. The word FIRE shall appear on the manual station in letters one half inch (12.7 mm) in size or larger.

E. Conventional Photoelectric Area Smoke Detectors

- 1) Photoelectric smoke detectors shall be a 24 VDC, two wire, ceiling-mounted, light scattering type using an LED light source.
- 2) Each detector shall contain a remote LED output and a built-in test switch.
- 3) Detector shall be provided on a twist-lock base.
- 4) It shall be possible to perform a calibrated sensitivity and performance test on the detector without the need for the generation of smoke. The test method shall test all detector circuits.
- 5) A visual indication of an alarm shall be provided by dual latching Light Emitting Diodes (LEDs), on the detector, which may be seen from ground level over 360 degrees. These LEDs shall flash at least every 10 seconds, indicating that power is applied to the detector.
- 6) The detector shall not go into alarm when exposed to air velocities of up to 3000 feet (914.4 m) per minute.
- 7) The detector screen and cover assembly shall be easily removable for field cleaning of the detector chamber.
- 8) All field wire connections shall be made to the base through the use of a clamping plate and screw.

F. Duct Smoke Detectors

Duct smoke detectors shall be a 24 VDC type with visual alarm and power indicators, and a reset switch. Each detector shall be installed upon the composite supply/return air ducts(s), with properly sized air sampling tubes.

G. Projected Beam Detectors

- 1) The projected beam type shall be a 4-wire 24 VDC device.
- 2) The detector shall be listed to UL 268 and shall consist of a separate transmitter and receiver capable of being powered separately or together.
- 3) The detector shall operate in either a short range (30' - 100') or long range (100' - 330') mode.
- 4) The temperature range of the device shall be -22 degrees F to 131 degrees F.
- 5) The detector shall feature a bank of four alignment LEDs on both the receiver and the transmitter that are used to ensure proper alignment of unit without special tools.
- 6) Beam detectors shall feature automatic gain control which will compensate for gradual signal deterioration from dirt accumulation on lenses.
- 7) The unit shall be both ceiling and wall mountable.
- 8) The detector shall have the ability to be tested using calibrated test filters or magnet activated remote test station.

H. Automatic Conventional Heat Detectors

- 1) Automatic heat detectors shall have a combination rate of rise and fixed temperature rated at 135 degrees Fahrenheit (57.2 Celsius) for areas where ambient

temperatures do not exceed 100 degrees (37.7 Celsius), and 200 degrees (93.33 Celsius) for areas where the temperature does not exceed 150 degrees (65.5 Celsius).

- 2) Automatic heat detectors shall be a low profile, ceiling mount type with positive indication of activation.
- 3) The rate of rise element shall consist of an air chamber, a flexible metal diaphragm, and a factory calibrated, moisture-proof, trouble free vent, and shall operate when the rate of temperature rise exceeds 15 degrees F (9.4 degrees C) per minute.
- 4) The fixed temperature element shall consist of a fusible alloy retainer and actuator shaft.
- 5) Automatic heat detectors shall have a smooth ceiling rating of 2500 square feet (762 square meters).

I. Waterflow Indicator:

- 1) Waterflow switches shall be provided by the mechanical contractor and connected under this section.

J. Sprinkler and Standpipe Valve Supervisory Switches:

- 1) Each sprinkler system water supply control valve riser, zone control valve, and standpipe system riser control valve shall be equipped with a supervisory switch.
- 2) PIV (post indicator valve) or main gate valves shall be equipped with a supervisory switch.
- 3) Valve supervisory switches shall be connected under this section and provided by mechanical contractor.

K. Alphanumeric LCD Type Annunciator:

- 1) The alphanumeric display annunciator shall be a supervised, remotely located back-lit LCD display containing a minimum of eighty (80) characters for alarm annunciation in clear English text.
- 2) The LCD annunciator shall display all alarm and trouble conditions in the system.
- 3) An audible indication of alarm shall be integral to the alphanumeric display.
- 4) The display shall be UL listed for fire alarm application.
- 5) It shall be possible to connect up to 32 LCD displays and be capable of wiring distances up to 6,000 feet from the control panel.
- 6) The annunciator shall connect to a separate, dedicated "terminal mode" EIA-485 interface. This is a two-wire loop connection and shall be capable of distances to 6,000 feet. Each terminal mode LCD display shall mimic the main control panel.
- 7) The system shall allow a minimum of 32 terminal mode LCD annunciators. Up to 10 LCD annunciators shall be capable of the following system functions: Acknowledge, Signal Silence and Reset, which shall be protected from unauthorized use by a keyswitch or password.
- 8) Smoke Control System Panel:

- a. This unit shall provide indication of status and supervisory conditions for each device associated with the O'Malley hall building atrium smoke evacuation system. This panel shall be included in the FACP or annunciator located in the entry lobby.
- b. Switches shall be available for control of each exhaust fan individually. Indication of fan status and supervisory conditions for each device as shown on plans Provide all functions required by the building code for smoke evacuation control.

L. Fixed Emergency Microphone

- 1) The microphone cabinet shall be painted red and clearly labeled as "Emergency Microphone." The cabinets shall be located at the FACP.
- 2) The handset cradle shall have a switch connection so that lifting the handset off of the cradle shall send a signal to the fire command center, which shall audibly and visually indicate its on-line (off-hook) condition.

M. All interfaces and associated equipment are to be protected so that they will not be affected by voltage surges or line transients consistent with UL standard 864.

N. Field Wiring Terminal Blocks

For ease of service all panel I/O wiring terminal blocks shall be removable, plug-in types and have sufficient capacity for #18 to #12 AWG wire. Terminal blocks that are permanently fixed are not acceptable.

O. Printer

- 1) The printer shall provide hard-copy printout of all changes in status of the system and shall time-stamp such printouts with the current time-of-day and date. The printer shall be standard carriage with 80-characters per line and shall use standard pin-feed paper. The printer shall be enclosed in a separate cabinet suitable for placement on a desktop or table. The printer shall communicate with the control panel using an interface complying with Electrical Industries Association standard EIA-232D. Power to the printer shall be 120 VAC @ 60 Hz.
- 2) The system shall have a strip printer capable of being mounted directly in the main FACP enclosure. Alarms shall be printed in easy-to-read RED, other messages, such as a trouble, shall be printed in BLACK. This printer shall receive power from the system power supply and shall operate via battery back-up if AC mains are lost. The strip printer shall be UL 864 listed.
- 3) The system shall have a strip printer capable of being mounted directly in the main FACP enclosure. Alarms shall be printed in easy-to-read RED, other messages, such as a trouble, shall be printed in BLACK. This printer shall receive power from

the system power supply and shall operate via battery back-up if AC mains are lost. The strip printer shall be UL 864 listed.

2.05 SYSTEM COMPONENTS - ADDRESSABLE DEVICES

A. Addressable Devices - General

- 1) Addressable devices shall use simple to install and maintain decade, decimal address switches. Devices shall be capable of being set to an address in a range of 001 to 159.
- 2) Addressable devices, which use a binary-coded address setting method, such as a DIP-switch, are not an allowable substitute.
- 3) Detectors shall be intelligent (analog) and addressable, and shall connect with two wires to the fire alarm control panel Signaling Line Circuits.
- 4) Addressable smoke and thermal detectors shall provide dual alarm and power/polling LEDs. Both LEDs shall flash green under normal conditions, indicating that the detector is operational and in regular communication with the control panel, and both LEDs shall be placed into steady red illumination by the control panel, indicating that an alarm condition has been detected. If required, the LED flash shall have the ability to be removed from the system program. An output connection shall also be provided in the base to connect an external remote alarm LED.
- 5) The fire alarm control panel shall permit detector sensitivity adjustment through field programming of the system. The panel on a time-of-day basis shall automatically adjust sensitivity.
- 6) Using software in the FACP, detectors shall automatically compensate for dust accumulation and other slow environmental changes that may affect their performance. The detectors shall be listed by UL as meeting the calibrated sensitivity test requirements of NFPA Standard 72, Chapter 7.
- 7) The detectors shall be ceiling-mount or wall-mount as shown on drawings and shall include a separate twist-lock base with tamper proof feature. Bases shall include a sounder base with a built-in (local) sounder rated at 85 DBA minimum, a relay base and an isolator base designed for Style 7 applications.
- 8) The detectors shall provide a test means whereby they will simulate an alarm condition and report that condition to the control panel. Such a test may be initiated at the detector itself (by activating a magnetic switch) or initiated remotely on command from the control panel.
- 9) Detectors shall also store an internal identifying type code that the control panel shall use to identify the type of device (ION, PHOTO, THERMAL).
- 10) Detectors will operate in an analog fashion, where the detector simply measures its designed environment variable and transmits an analog value to the FACP based on real-time measured values. The FACP software, not the detector, shall make the alarm/normal decision, thereby allowing the sensitivity of each detector to be set in the FACP program and allowing the system operator to view the current analog value of each detector.

- 11) Addressable devices shall store an internal identifying code that the control panel shall use to identify the type of device.
- 12) A magnetic test switch shall be provided to test detectors and modules. Detectors shall report an indication of an analog value reaching 100% of the alarm threshold.
- 13) Addressable modules shall mount in a 4-inch square (101.6 mm square), 2-1/8 inch (54 mm) deep electrical box. An optional surface mount Lexan enclosure shall be available.

B. Addressable Manual Fire Alarm Box (manual station)

- 1) Addressable manual fire alarm boxes shall, on command from the control panel, send data to the panel representing the state of the manual switch and the addressable communication module status. They shall use a key operated test-reset lock, and shall be designed so that after actual emergency operation, they cannot be restored to normal use except by the use of a key.
- 2) All operated stations shall have a positive, visual indication of operation and utilize a key type reset.
- 3) Manual fire alarm boxes shall be constructed of Lexan with clearly visible operating instructions provided on the cover. The word FIRE shall appear on the front of the stations in raised letters, 1.75 inches (44 mm) or larger.

C. Intelligent Photoelectric Smoke Detector

- 1) The detectors shall use the photoelectric (light-scattering) principal to measure smoke density and shall, on command from the control panel, send data to the panel representing the analog level of smoke density.

D. Intelligent Thermal Detectors

- 1) Thermal detectors shall be intelligent addressable devices rated at 135 degrees Fahrenheit (58 degrees Celsius) and have a rate-of-rise element rated at 15 degrees F (9.4 degrees C) per minute. It shall connect via two wires to the fire alarm control panel signaling line circuit.

E. Intelligent Duct Smoke Detector

- 1) The smoke detector housing shall accommodate either an intelligent ionization detector or an intelligent photoelectric detector, of that provides continuous analog monitoring and alarm verification from the panel.
- 2) When sufficient smoke is sensed, an alarm signal is initiated at the FACP, and appropriate action taken to change over air handling systems to help prevent the rapid distribution of toxic smoke and fire gases throughout the areas served by the duct system.

F. Addressable Dry Contact Monitor Module

- 1) Addressable monitor modules shall be provided to connect one supervised IDC zone of conventional alarm initiating devices (any N.O. dry contact device) to one of the fire alarm control panel SLCs.
- 2) The IDC zone shall be suitable for Style D or Style B operation. An LED shall be provided that shall flash under normal conditions, indicating that the monitor module is operational and in regular communication with the control panel.
- 3) For difficult to reach areas, the monitor module shall be available in a miniature package and shall be no larger than 2-3/4 inch (70 mm) x 1-1/4 inch (31.7 mm) x 1/2 inch (12.7 mm). This version need not include Style D or an LED.

G. Two Wire Detector Monitor Module

- 1) Addressable monitor modules shall be provided to connect one supervised IDC zone of conventional 2-wire smoke detectors or alarm initiating devices (any N.O. dry contact device).
- 2) The IDC zone shall be wired for Class B operation. An LED shall be provided that shall flash under normal conditions, indicating that the monitor module is operational and in regular communication with the control panel.

H. Addressable Control Module

- 1) Addressable control modules shall be provided to supervise and control the operation of one conventional NACs of compatible, 24 VDC powered, polarized audio/visual notification appliances.
- 2) The control module NAC shall be wired for Class B with up to 1 amp of inductive A/V signal, or 2 amps of resistive A/V signal operation.
- 3) Audio/visual power shall be provided by a separate supervised power circuit from the main fire alarm control panel or from a supervised UL listed remote power supply.
- 4) The control module shall be suitable for pilot duty applications and rated for a minimum of 0.6 amps at 30 VDC.

I. Addressable Relay Module

- 1) Addressable Relay Modules shall be available for HVAC control and other building functions. The relay shall be form C and rated for a minimum of 2.0 Amps resistive or 1.0 Amps inductive. The relay coil shall be magnetically latched to reduce wiring connection requirements, and to insure that 100% of all auxiliary relay or NACs may be energized at the same time on the same pair of wires.

J. Isolator Module

- 1) Isolator modules shall be provided to automatically isolate wire-to-wire short circuits on an SLC Class A or Class B branch. The isolator module shall limit the number of

modules or detectors that may be rendered inoperative by a short circuit fault on the SLC loop segment or branch. At least one isolator module shall be provided for each floor or protected zone of the building.

- 2) If a wire-to-wire short occurs, the isolator module shall automatically open-circuit (disconnect) the SLC. When the short circuit condition is corrected, the isolator module shall automatically reconnect the isolated section.
- 3) The isolator module shall not require address-setting, and its operations shall be totally automatic. It shall not be necessary to replace or reset an isolator module after its normal operation.
- 4) The isolator module shall provide a single LED that shall flash to indicate that the isolator is operational and shall illuminate steadily to indicate that a short circuit condition has been detected and isolated.

K. Smoke Control Annunciator

- 1) Provide all interfaces and programming to close smoke dampers and shut down air handling units based on smoke detection and system programming as directed and noted on drawings.

2.06 BATTERIES

- A. The battery shall have sufficient capacity to power the fire alarm system for not less than twenty-four hours plus 5 minutes of alarm upon a normal AC power failure.
- B. The batteries are to be completely maintenance free. No liquids are required. Fluid level checks for refilling, spills, and leakage shall not be required.
- C. If necessary to meet standby requirements, external battery and charger systems may be used.

PART 3 EXECUTION

3.01 INSTALLATION

- A. Installation shall be in accordance with the NEC, NFPA 72, local and state codes, as shown on the drawings, and as recommended by the major equipment manufacturer.
- B. All conduit, junction boxes, conduit supports and hangers shall be concealed in finished areas and may be exposed in unfinished areas. Smoke detectors shall not be installed prior to the system programming and test period. If construction is ongoing during this period, measures shall be taken to protect smoke detectors from contamination and physical damage.

- C. All fire detection and alarm system devices, control panels and remote annunciators shall be flush mounted when located in finished areas and may be surface mounted when located in unfinished areas.
- D. Manual fire alarm boxes shall be suitable for surface mounting or semi-flush mounting as shown on the plans, and shall be installed not less than 42 inches (1067 mm), nor more than 48 inches (122 mm) above the finished floor.

3.02 TEST

The service of a competent, factory-trained engineer or technician authorized by the manufacturer of the fire alarm equipment shall be provided to technically supervise and participate during all of the adjustments and tests for the system. All testing shall be in accordance with NFPA 72, Chapter 7.

- A. Before energizing the cables and wires, check for correct connections and test for short circuits, ground faults, continuity, and insulation.
- B. Close each sprinkler system flow valve and verify proper supervisory alarm at the FACP.
- C. Verify activation of all waterflow switches.
- D. Open initiating device circuits and verify that the trouble signal actuates.
- E. Open and short signaling line circuits and verify that the trouble signal actuates.
- F. Open and short notification appliance circuits and verify that trouble signal actuates.
- G. Ground all circuits and verify response of trouble signals.
- H. Check presence and audibility of tone at all alarm notification devices. Test sound levels and adjust all speakers to required levels in the Ohio Building Code. Adjust all strobes to required cd ratings. Verify all mechanical smoke dampers and system shut down signals are operating.
- I. Check installation, supervision, and operation of all intelligent smoke detectors using the walk test.
- J. Each of the alarm conditions that the system is required to detect should be introduced on the system. Verify the proper receipt and the proper processing of the signal at the FACP and the correct activation of the control points.
- K. When the system is equipped with optional features, the manufacturer's manual shall be consulted to determine the proper testing procedures. This is intended to address such

items as verifying controls performed by individually addressed or grouped devices, sensitivity monitoring, verification functionality and similar.

3.03 FINAL INSPECTION

- A. At the final inspection, a factory-trained representative of the manufacturer of the major equipment shall demonstrate that the system functions properly in every respect.
- B. Include all inspections required by the authority having jurisdiction.

3.04 INSTRUCTION

- A. Instruction shall be provided as required for operating the system. Hands-on demonstrations of the operation of all system components and the entire system including program changes and functions shall be provided.
- B. The contractor and/or the systems manufacturer's representatives shall provide a typewritten "Sequence of Operation."

END OF SECTION

SECTION 311000 - SITE CLEARING

PART 1 - GENERAL

1.1 SECTION REQUIREMENTS

- A. Traffic: Minimize interference with adjoining roads, streets, walks, and other adjacent occupied or used facilities during site operations.
- B. Salvageable Improvements: Carefully remove items indicated to be salvaged and store on Owner's premises where indicated.
- C. Utility Locator Service: Notify Miss Dig for area where Project is located before site clearing.
- D. Do not commence demolition operations until temporary erosion- and sedimentation-control and plant-protection measures are in place.

PART 2 - PRODUCTS (Not Used)

PART 3 - EXECUTION

3.1 PREPARATION

- A. Protect and maintain benchmarks and survey control points from disturbance.
- B. Locate and clearly flag trees and vegetation to remain or to be relocated.
- C. Protect remaining trees and shrubs from damage and maintain vegetation. Employ a licensed arborist to repair tree and shrub damage. Restore damaged vegetation. Replace damaged trees that cannot be restored to full growth, as determined by arborist.
- D. Do not store materials or equipment or permit excavation within drip line of remaining trees.
- E. Protect site improvements to remain from damage. Restore damaged improvements to condition existing before start of site demolition.
- F. Provide temporary erosion- and sedimentation-control measures to prevent soil erosion and discharge of soil-bearing water runoff or airborne dust to adjacent properties / areas and walkways, according to the sediment and erosion control plan.
- G. Locate, identify, disconnect, and seal or cap off utilities indicated to be removed.
 - 1. Arrange with utility companies to shut off indicated utilities.

3.2 SITE CLEARING

- A. Remove existing above - and below- grade improvements as indicated and as necessary to facilitate new construction.
- B. Remove slabs, paving, curbs, gutters, and aggregate base as indicated.
 - 1. Neatly saw-cut length of existing pavement to remain before removing existing pavement.
- C. Dispose of waste materials, including trash, debris, and excess topsoil, off Owner's property. Burning waste materials on-site is not permitted.
 - 1. Separate recyclable materials produced during site demolition from other nonrecyclable materials. Store or stockpile without intermixing with other materials and transport them to recycling facilities.

END OF SECTION 311000

SECTION 312000 - EARTH MOVING

PART 1 – GENERAL

1.1 DESCRIPTION OF WORK

- A. This section specifies the requirements for furnishing all equipment, materials, labor, tools, and techniques for earthwork including, but not limited to, the following:
1. Site preparation.
 2. Excavation.
 3. Filling and backfilling.
 4. Grading.
 5. Soil Disposal.
 6. Clean Up.

1.2 DEFINITIONS

- A. Unsuitable Materials:
1. Fills: Topsoil; frozen materials; construction materials and materials subject to decomposition; clods of clay and stones larger than 75 mm (3 inches); organic material, including silts, which are unstable; and inorganic materials, including silts, too wet to be stable and any material with a liquid limit and plasticity index exceeding 40 and 15 respectively. Unsatisfactory soils also include satisfactory soils not maintained within 2 percent of optimum moisture content at time of compaction, as defined by ASTM D 698.
 2. Existing Subgrade (Except Footing Subgrade): Same materials as 1.2.A.1, that are not capable of direct support of slabs, pavement, and similar items with possible exception of improvement by compaction, proofrolling, or similar methods.
 3. Existing Subgrade (Footings Only): Same as paragraph 1, but no fill or backfill. If materials differ from reference borings and design requirements, excavate to acceptable strata subject to Engineer of Record's approval.
 - a) Building Earthwork: Earthwork operations required in area enclosed by a line located 1500 mm (5 feet) outside of principal building perimeter. It also includes earthwork required for auxiliary structures and buildings.
 - b) Trench Earthwork: Trenchwork required for utility lines.
 - c) Site Earthwork: Earthwork operations required in area outside of a line located 1500 mm (5 feet) outside of principal building perimeter and within new construction area with exceptions noted above.
 - d) Degree of compaction: Degree of compaction is expressed as a percentage of maximum density obtained by laboratory test procedure. This percentage of maximum density is obtained through use of data provided from results of

field test procedures presented in ASTM D1556, ASTM D2167, and ASTM D2922.

- e) Fill: Satisfactory soil materials used to raise existing grades. In the Construction Documents, the term “fill” means fill or backfill as appropriate.
- f) Backfill: Soil materials or controlled low strength material used to fill an excavation.
- g) Unauthorized excavation: Removal of materials beyond indicated sub-grade elevations or indicated lines and dimensions without written authorization by the Engineer of Record. No payment will be made for unauthorized excavation or remedial work required to correct unauthorized excavation.
- h) Authorized additional excavation: Removal of additional material authorized by the Engineer of Record based on the determination by the Owner’s soils testing agency that unsuitable bearing materials are encountered at required sub-grade elevations. Removal of unsuitable material and its replacement as directed will be paid on basis of Conditions of the Contract relative to changes in work.
- i) Subgrade: The undisturbed earth or the compacted soil layer immediately below granular sub-base, drainage fill, or topsoil materials.
- j) Structure: Buildings, foundations, slabs, tanks, curbs, mechanical and electrical appurtenances, or other man-made stationary features constructed above or below the ground surface.
- k) Borrow: Satisfactory soil imported from off-site for use as fill or backfill.
- l) Drainage course: Layer supporting slab-on-grade used to minimize capillary flow of pore water.
- m) Bedding course: Layer placed over the excavated sub-grade in a trench before laying pipe. Bedding course shall extend up to the springline of the pipe.
- n) Sub-base Course: Layer placed between the sub-grade and base course for asphalt paving or layer placed between the sub-grade and a concrete pavement or walk.
- o) Utilities include on-site underground pipes, conduits, ducts, and cables as well as underground services within buildings.
- p) Debris: Debris includes all materials located within the designated work area not covered in the other definitions and shall include but not be limited to items like vehicles, equipment, appliances, building materials or remains thereof, tires, any solid or liquid chemicals or products stored or found in containers or spilled on the ground.
- q) Contaminated soils: Soil that contains contaminants as defined and determined by the Engineer of Record or the Owner’s testing agency.

1.3 RELATED WORK

- A. Site preparation: Section 312319, DEWATERING.
- B. Paving sub-grade requirements: Section 321216, ASPHALT PAVING.

1.4 CLASSIFICATION OF EXCAVATION

- A. Unclassified Excavation: Removal and disposal of pavements and other man-made obstructions visible on surface; utilities, and other items including underground structures indicated to be demolished and removed; together with any type of materials regardless of character of material and obstructions encountered.

- B. Rock Excavation:
 - 1. Trenches and Pits: Removal and disposal of solid, homogenous, interlocking crystalline material with firmly cemented, laminated, or foliated masses or conglomerate deposits that cannot be excavated with a late-model, track-mounted hydraulic excavator; equipped with a 1050 mm (42 inch) wide, short-tip-radius rock bucket; rated at not less than 103 kW (138 hp) flywheel power with bucket-curling force of not less than 125 kN (28,090 lbf) and stick-crowd force of not less than 84.5 kN (19,000 lbf); measured according to SAE J-1179. Trenches in excess of 3000 mm (10 feet) wide and pits in excess of 9000 mm (30 feet) in either length or width are classified as open excavation.
 - 2. Open Excavation: Removal and disposal of solid, homogenous, interlocking crystalline material firmly cemented, laminated, or foliated masses or conglomerate deposits that cannot be dislodged and excavated with a late-model, track-mounted loader; rated at not less than 157 kW (210 hp) flywheel power and developing a minimum of 216 kN (48,510 lbf) breakout force; measured according to SAE J-732.
 - 3. Other types of materials classified as rock are unstratified masses, conglomerated deposits and boulders of rock material exceeding 0.76 m³ (1 cubic yard) for open excavation, or 0.57 m³ (3/4 cubic yard) for footing and trench excavation that cannot be removed by rock excavating equipment equivalent to the above in size and performance ratings, without systematic drilling, ram hammering, ripping, or blasting, when permitted.
 - 4. Blasting: Removal and disposal of solid, homogenous, interlocking crystalline material firmly cemented, laminated, or foliated masses or conglomerate deposits that cannot be removed with conventional methods may not be performed by blasting.
 - 5. Definitions of rock and guidelines for equipment are presented for general information purposes only. The Contractor is expected to evaluate the site and extent and competency of the rock and to determine both quantity estimations and removal equipment and efforts.

1.5 SUBMITTALS

- A. Submit in accordance with Section 013000, ADMINISTRATIVE REQUIREMENTS.

- B. Furnish to Engineer of Record:
 - 1. Soil samples.
 - a. Classification in accordance with ASTM D2487 for each on-site or borrow soil material proposed for fill, backfill, engineered fill, or structural fill.

- b. Laboratory compaction curve in accordance with ASTM D 698 for each on site or borrow soil material proposed for fill, backfill, engineered fill, or structural fill.
- c. Test reports for compliance with ASTM D 2940 requirements for subbase material.
- d. Pre-excavation photographs and videotape in the vicinity of the existing structures to document existing site features, including surfaces finishes, cracks, or other structural blemishes that might be misconstrued as damage caused by earthwork operations.
- e. The Contractor shall submit a scale plan daily that defines the location, limits, and depths of the area excavated.

1.6 APPLICABLE PUBLICATIONS

- A. Publications listed below form a part of this specification to extent referenced. Publications are referenced in text by basic designation only.
- B. American Society for Testing and Materials (ASTM):
 - D448-03a Standard Classification for Sizes of Aggregate for Road and Bridge Construction
 - D698-00ae1 Standard Test Methods for Laboratory Compaction Characteristics of Soil Using Standard Effort (12,400 ft. lbf/ft³ (600 kN m/m³))
 - D1556-00 Standard Test Method for Density and Unit Weight of Soil in Place by the Sand-Cone Method
 - D1557-02e1 Standard Test Methods for Laboratory Compaction Characteristics of Soil Using Modified Effort (56,000 ft-lbf/ft³ (2700 kN m/m³))
 - D2167-94 (2001) Standard Test Method for Density and Unit Weight of Soil in Place by the Rubber Balloon Method
 - D2487-06 Standard Classification of Soil for Engineering Purposes (Unified Soil Classification System)
 - D2922-05 Standard Test Methods for Density of Soil and Soil-Aggregate in Place by Nuclear Methods (Shallow Depth)
 - D2940-03 Standard Specifications for Graded Aggregate Material for Bases or Subbases for Highways or Airports
- C. Society of Automotive Engineers (SAE)
 - J732-92 Specification Definitions - Loaders

J1179-02 Hydraulic Excavator and Backhoe Digging Forces

PART 2 - PRODUCTS

2.1 MATERIALS

- A. General: Provide borrow soil material when sufficient satisfactory soil materials are not available from excavations.
- B. Fills: Material in compliance with ASTM D2487 Soil Classification Groups GW, GP, GM, SW, SP, SM, SC, and ML, or any combination of these groups; free of rock or gravel larger than 75 mm (3 inches) in any dimension, debris, waste, frozen materials, vegetation, and other deleterious matter. Material approved from on site or off site sources having a minimum dry density of 1760 kg/m³ (110 pcf), a maximum Plasticity Index of 15, and a maximum Liquid Limit of 40.
- C. Engineered Fill: Naturally or artificially graded mixture of compliance with ASTM D2487 Soil Classification Groups GW, GP, GM, SW, SP, SM, SC, and ML, or any combination of these groups, or as approved by the Engineer or material with at least 90 percent passing a 37.5-mm (1 1/2-inch) sieve and not more than 12 percent passing a 75- μ m (No. 200) sieve, per ASTM D2940;.
- D. Bedding: Naturally or artificially graded mixture of natural or crushed gravel, crushed stone, and natural or crushed sand; ASTM D2940; except with 100 percent passing a 25 mm (1 inch) sieve and not more than 8 percent passing a 75- μ m (No. 200) sieve.
- E. Drainage Fill: Washed, narrowly graded mixture of crushed stone, or crushed or uncrushed gravel; ASTM D448; coarse-aggregate grading Size 57; with 100 percent passing a 37.5 mm (1 1/2-inch) sieve and 0 to 5 percent passing a 2.36 mm (No. 8) sieve.
- F. Granular Fill:
 - 1. Under concrete slab, crushed stone or gravel graded from 25 mm (1 inch) to 4.75 mm (No. 4), per ASTM D 2940.
 - 2. Bedding for sanitary and storm sewer pipe, crushed stone or gravel graded from 13 mm (1/2 inch) to 4.75 mm (No 4), per ASTM D 2940.

PART 3 - EXECUTION

3.1 SITE PREPARATION

- A. Clearing: Clear within limits of earthwork operations as shown. Work includes removal of trees, shrubs, fences, foundations, incidental structures, paving, debris, trash, and other obstructions. Remove materials from the Property.

- B. Grubbing: Remove stumps and roots 75 mm (3 inch) and larger diameter. Undisturbed sound stumps, roots up to 75 mm (3 inch) diameter, and nonperishable solid objects a minimum of 900 mm (3 feet) below subgrade or finished embankment may be left.
- C. Trees and Shrubs: Trees and shrubs, not shown for removal, may be removed from areas within 4500 mm (15 feet) of new construction and 2250 mm (7.5 feet) of utility lines when removal is approved in advance by Engineer of Record. Remove materials from the Property. Trees and shrubs, shown to be transplanted, shall be dug with a ball of earth and burlapped in accordance with latest issue of, "American Standard for Nursery Stock" of the American Association of Nurserymen, Inc. Transplant trees and shrubs to a permanent or temporary position within two hours after digging. Maintain trees and shrubs held in temporary locations by watering as necessary and feeding semiannually with liquid fertilizer with a minimum analysis of 5 percent nitrogen, 10 percent phosphorus, and 5 percent potash. Maintain plants moved to permanent positions as specified for plants in temporary locations until conclusion of contract. Box, and otherwise protect from damage, existing trees and shrubs which are not shown to be removed in construction area. Immediately repair damage to existing trees and shrubs by trimming, cleaning and painting damaged areas, including roots, in accordance with standard industry horticultural practice for the geographic area and plant species. Do not store building materials closer to trees and shrubs, that are to remain, than farthest extension of their limbs.
- D. Stripping Topsoil: Strip topsoil from within limits of earthwork operations as specified. Topsoil shall be a fertile, friable, natural topsoil of loamy character and characteristic of locality. Topsoil shall be capable of growing healthy horticultural crops of grasses. Stockpile topsoil and protect as directed by Engineer of Record. Eliminate foreign materials, such as weeds, roots, stones, subsoil, frozen clods, and similar foreign materials larger than 0.014 m³ (1/2 cubic foot) in volume, from soil as it is stockpiled. Retain topsoil on station. Remove foreign materials larger than 50 mm (2 inches) in any dimension from topsoil used in final grading. Topsoil work, such as stripping, stockpiling, and similar topsoil work shall not, under any circumstances, be carried out when soil is wet so that the composition of the soil will be destroyed.
- E. Concrete Slabs and Paving: Score deeply or saw cut to insure a neat, straight cut, sections of existing concrete slabs and paving to be removed where excavation or trenching occurs. Extend pavement section to be removed a minimum of 300 mm (12 inches) on each side of widest part of trench excavation and insure final score lines are approximately parallel unless otherwise indicated. Remove material from the Property.
- F. Lines and Grades: Registered Professional Land Surveyor or Registered Civil Engineer, specified in Section 01 00 00, GENERAL REQUIREMENTS, shall establish lines and grades.
 - 1. Grades shall conform to elevations indicated on plans within the tolerances herein specified. Generally grades shall be established to provide a smooth surface, free from irregular surface changes. Grading shall comply with compaction requirements and grade cross sections, lines, and elevations indicated. Where spot grades are indicated the grade shall be established based on interpolation of the elevations between the spot grades while maintaining appropriate transition at structures and paving and uninterrupted drainage flow into inlets.

2. Locations of existing and proposed elevations indicated on plans, except spot elevations, are from a site survey that measured spot elevations and subsequently generated existing contours and spot elevations. Proposed spot elevations and contour lines have been developed utilizing the existing conditions survey and developed contour lines and may be approximate. Contractor is responsible to notify Engineer of Record of any differences between existing elevations shown on plans and those encountered on site by Surveyor/Engineer described above. Notify Engineer of Record of any differences between existing or constructed grades, as compared to those shown on the plans.
 3. Subsequent to establishment of lines and grades, Contractor will be responsible for any additional cut and/or fill required to ensure that site is graded to conform to elevations indicated on plans.
 4. Finish grading is specified in Section 321216 – ASPHALT PAVING.
- G. Disposal: All materials removed from the property shall be disposed of at a legally approved site, for the specific materials, and all removals shall be in accordance with all applicable Federal, State and local regulations. No burning of materials is permitted onsite.

3.2 EXCAVATION

- A. Shoring, Sheet piling and Bracing: Shore, brace, or slope, its angle of repose or to an angle considered acceptable by the Engineer of Record, banks of excavations to protect workmen, banks, adjacent paving, structures, and utilities.
1. Design of the temporary support of excavation system is the responsibility of the Contractor.
 2. Construction of the support of excavation system shall not interfere with the permanent structure and may begin only after a review by the Engineer of Record.
 3. Extend shoring and bracing to a minimum of 1500 mm (5 feet) below the bottom of excavation. Shore excavations that are carried below elevations of adjacent existing foundations.
 4. If bearing material of any foundation is disturbed by excavating, improper shoring or removal of existing or temporary shoring, placing of backfill, and similar operations, the Contractor shall underpin the existing foundation, as directed by Engineer of Record, at no additional cost to the Owner. Do not remove shoring until permanent work in excavation has been inspected and approved by Engineer of Record.
- B. Subgrade Protection: Protect subgrades from softening, undermining, washout, or damage by rain or water accumulation. Reroute surface water runoff from excavated areas and not allow water to accumulate in excavations. Do not use excavated trenches as temporary drainage ditches. When subgrade for foundations has been disturbed by water, remove disturbed material to firm undisturbed material after water is brought under control. Replace disturbed subgrade in trenches with concrete or material approved by the Engineer of Record.

C. Proofrolling:

1. After rough grade has been established in cut areas and prior to placement of fill in fill areas under building and pavements, proofroll exposed subgrade with a fully loaded dump truck to check for pockets of soft material.
2. Proofrolling shall consist of at least two complete passes with one pass being in a direction perpendicular to preceding one. Remove any areas that deflect, rut, or pump excessively during proofrolling, or that fail to consolidate after successive passes to suitable soils and replaced with compacted fill. Maintain subgrade until succeeding operation has been accomplished.

D. Building Earthwork:

1. Excavation shall be accomplished as required by drawings and specifications.
2. Excavate foundation excavations to solid undisturbed subgrade.
3. Remove loose or soft materials to a solid bottom.
4. Fill excess cut under footings or foundations with 25 MPa (3000 psi) concrete poured separately from the footings.
5. Do not tamp earth for backfilling in footing bottoms, except as specified.
6. Slope grades to direct water away from excavations and to prevent ponding.

E. Trench Earthwork:

1. Utility trenches (except sanitary and storm sewer):

- a. Excavate to a width as necessary for sheeting and bracing and proper performance of the work.
- b. Grade bottom of trenches with bell holes scooped out to provide a uniform bearing.
- c. Support piping on undisturbed earth unless a mechanical support is shown.
- d. Length of open trench in advance of piping laying shall not be greater than is authorized by Engineer of Record.

2. Sanitary and storm sewer trenches:

- a. Trench width below a point 150 mm (6 inches) above top of pipe shall be 600 mm (24 inches) maximum for pipe up to and including 300 mm (12 inches) diameter, and four-thirds diameter of pipe plus 200 mm (8 inches) for pipe larger than 300 mm (12 inches). Width of trench above that level shall be as necessary for sheeting and bracing and proper performance of the work.
- b. Bed bottom quadrant of pipe on undisturbed soil or granular fill.
 - 1) Undisturbed: Bell holes shall be no larger than necessary for jointing. Backfill up to a point 300 mm (12 inches) above top of pipe shall be clean earth placed and tamped by hand.
 - 2) Granular Fill: Depth of fill shall be a minimum of 75 mm (3 inches) plus one sixth of pipe diameter below pipe to 300 mm (12 inches) above top of pipe. Place and tamp fill material by hand.

- c. Place and compact as specified remainder of backfill using acceptable excavated materials. Do not use unsuitable materials.
 - d. Use granular fill for bedding where rock or rocky materials are excavated.
- F. Site Earthwork: Earth excavation includes excavating pavements and obstructions visible on surface; underground structures, utilities, and other items indicated to be removed; together with soil, boulders, and other materials not classified as rock or unauthorized excavation. Excavation shall be accomplished as required by drawings and specifications. Excavate to indicated elevations and dimensions within a tolerance of plus or minus 25 mm (1 inch). Extend excavations a sufficient distance from structures for placing and removing concrete formwork, for installing services and other construction, complying with OSHA requirements, and for inspections. Remove subgrade materials that are determined by Engineer of Record as unsuitable, and replace with acceptable material. If there is a question as to whether material is unsuitable or not, the contractor shall obtain samples of the material, under the direction of the Engineer of Record, and the materials shall be examined by an independent testing laboratory for soil classification to determine whether it is unsuitable or not. Testing of the soil shall be performed by a certified Testing Laboratory. When unsuitable material is encountered and removed, contract price and time will be adjusted in accordance with Articles, DIFFERING SITE CONDITIONS, CHANGES and CHANGES-SUPPLEMENT of the GENERAL CONDITIONS as applicable. Adjustments to be based on volume in cut section only.

1. Site Grading:

- a. Provide a smooth transition between adjacent existing grades and new grades.
- b. Cut out soft spots, fill low spots, and trim high spots to comply with required surface tolerances.
- c. Slope grades to direct water away from buildings and to prevent ponds from forming where not designed. Finish subgrades to required elevations within the following tolerances:
 - 1) Lawn or Unpaved Areas: Plus or minus 25 mm (1 inch).
 - 2) Walks: Plus or minus 13 mm (1/2 inch).
 - 3) Pavements: Plus or minus 13 mm (1/2 inch).
- d. Grading Inside Building Lines: Finish subgrade to a tolerance of 13 mm (1/2 inch) when tested with a 3000 mm (10 foot) straightedge.

3.3 FILLING AND BACKFILLING

- A. General: Do not fill or backfill until all debris, water, unsatisfactory soil materials, obstructions, and deleterious materials have been removed from excavation. For fill and backfill, use excavated materials and borrow meeting the criteria specified herein, as applicable. Borrow will be supplied at no additional cost to the Owner. Do not use unsuitable excavated materials. Do not backfill until foundation walls have been completed above grade and adequately braced, waterproofing or dampproofing applied, foundation drainage, and pipes coming in contact with backfill have been installed and work inspected and approved by Engineer of Record.

- B. Placing: Place materials in horizontal layers not exceeding 300 mm (12 inches) in loose depth for material compacted by heavy compaction equipment, and not more than 150 mm (6 inches) in loose depth for material compacted by hand-operated tampers and then compacted. Place backfill and fill materials evenly on all sides of structures to required elevations, and uniformly along the full length of each structure. Place no material on surfaces that are muddy, frozen, or contain frost.
- C. Compaction: Compact with approved tamping rollers, sheepsfoot rollers, pneumatic tired rollers, steel wheeled rollers, vibrator compactors, or other approved equipment (hand or mechanized) well suited to soil being compacted. Do not operate mechanized vibratory compaction equipment within 3000 mm (10 feet) of new or existing building walls without prior approval of Engineer of Record. Moisten or aerate material as necessary to provide moisture content that will readily facilitate obtaining specified compaction with equipment used. Compact soil to not less than the following percentages of maximum dry density, according to ASTM D698 or ASTM D1557 as specified below:
1. Fills, Embankments, and Backfill
 - a. Under proposed structures, building slabs, steps, and paved areas, scarify and recompact top 300 mm (12 inches) of existing subgrade and each layer of backfill or fill material in accordance with D698 and 95 percent.
 - b. Curbs, curbs and gutters, ASTM D698 and 95 percent.
 - c. Under Sidewalks, scarify and recompact top 150 mm (6 inches) below subgrade and compact each layer of backfill or fill material in accordance with ASTM D698 and 95 percent.
 - d. Landscaped areas, top 400 mm (16 inches), ASTM D698 and 85 percent.
 - e. Landscaped areas, below 400 mm (16 inches) of finished grade, ASTM D698 and 90 percent.
 2. Natural Ground (Cut or Existing)
 - a. Under building slabs, steps and paved areas, top 150 mm (6 inches), ASTM D698 and 95 percent.
 - b. Curbs, curbs and gutters, top 150 mm (6 inches), ASTM D698 and 95 percent.
 - c. Under sidewalks, top 150 mm (6 inches), ASTM D698 and 95 percent.

3.5 GRADING

- A. General: Uniformly grade the areas within the limits of this section, including adjacent transition areas. Smooth the finished surface within specified tolerance. Provide uniform levels or slopes between points where elevations are indicated, or between such points and existing finished grades. Provide a smooth transition between abrupt changes in slope.
- B. Cut rough or sloping rock to level beds for foundations. In pipe spaces or other unfinished areas, fill low spots and level off with coarse sand or fine gravel.
- C. Slope backfill outside building away from building walls for a minimum distance of 1800 mm (6 feet).

- D. Finish grade earth floors in pipe basements as shown to a level, uniform slope and leave clean.
- E. Finished grade shall be at least 150 mm (6 inches) below bottom line of window or other building wall openings unless greater depth is shown.
- F. Place crushed stone or gravel fill under concrete slabs on grade, tamped, and leveled. Thickness of fill shall be 150 mm (6 inches) unless otherwise shown.
- G. Finish subgrade in a condition acceptable to Engineer of Record at least one day in advance of paving operations. Maintain finished subgrade in a smooth and compacted condition until succeeding operation has been accomplished. Scarify, compact, and grade subgrade prior to further construction when approved compacted subgrade is disturbed by Contractor's subsequent operations or adverse weather.
- H. Grading for Paved Areas: Provide final grades for both subgrade and base course to +/- 6 mm (0.25 inches) of indicated grades.

3.6 DISPOSAL OF UNSUITABLE AND EXCESS EXCAVATED MATERIAL

- A. Disposal: Remove surplus satisfactory soil and waste material, including unsatisfactory soil, trash, and debris, and legally dispose of it off the property.
- B. Place excess excavated materials suitable for fill and/or backfill on site where directed.
- C. Remove from site and dispose of any excess excavated materials after all fill and backfill operations have been completed.
- D. Segregate all excavated contaminated soil designated by the Engineer of Record from all other excavated soils, and stockpile on site on two 0.15 mm (6 mil) polyethylene sheets with a polyethylene cover. A designated area shall be selected for this purpose. Dispose of excavated contaminated material in accordance with State and Local requirements.

3.7 CLEAN UP

- A. Upon completion of earthwork operations, clean areas within contract limits, remove tools, and equipment. Provide site clear, clean, free of debris, and suitable for subsequent construction operations. Remove all debris, rubbish, and excess material from the Property.

END OF SECTION 312000

SECTION 312319 – DEWATERING

PART 1 – GENERAL

1.1 DESCRIPTION

- A. This section specifies performance of dewatering required to lower and control ground water table levels and hydrostatic pressures to permit excavation, backfill, and construction to be performed in the dry. Control of surface water shall be considered as part of the work under this specification.

1.2 SUMMARY

- A. The work to be completed by the Contractor includes, but is not necessarily limited to the following:
 - 1. Implementation of the Erosion and Sedimentation Control Plan.
 - 2. Dewater excavations, including seepage and precipitation.
- B. The Contractor shall be responsible for providing all materials, equipment, labor, and services necessary for care of water and erosion control. Excavation work shall not begin before the Erosion and Sedimentation Control Plan is in place.

1.3 REQUIREMENT

- A. Dewatering system shall be of sufficient size and capacity necessary to lower and maintain ground water table to an elevation at least 300 mm (1 foot) below lowest foundation subgrade or bottom of pipe trench and to allow material to be excavated in a reasonably dry condition. Materials to be removed shall be sufficiently dry to permit excavation to grades shown and to stabilize excavation slopes where sheeting is not required. Operate dewatering system continuously until backfill work has been completed.
- B. Reduce hydrostatic head below any excavation to the extent that water level in the construction area is a minimum of 300 mm (1 foot) below prevailing excavation surface.
- C. Prevent loss of fines, seepage, boils, quick conditions or softening of foundation strata.
- D. Maintain stability of sides and bottom of excavation.
- E. Construction operations are performed in the dry.
- F. Control of surface and subsurface water is part of dewatering requirements. Maintain adequate control so that:

1. The stability of excavated and constructed slopes are not adversely affected by saturated soil, including water entering prepared subbase and subgrades where underlying materials are not free draining or are subject to swelling or freeze-thaw action.
 2. Erosion is controlled.
 3. Flooding of excavations or damage to structures does not occur.
 4. Surface water drains away from excavations.
 5. Excavations are protected from becoming wet from surface water, or insure excavations are dry before additional work is undertaken.
- G. Permitting Requirements: The contractor shall comply with and obtain the required State, City, and/or County permits where the work is performed.

1.4 RELATED WORK

- A. Excavation, backfilling, site grade and utilities: Section 312000, EARTH MOVING.

1.5 SUBMITTALS

- A. Submit in accordance with Section 013000, ADMINISTRATIVE REQUIREMENTS.
- B. Drawings and Design Data:
1. Submit drawings and data showing the method to be employed in dewatering excavated areas 30 days before commencement of excavation.
 2. Material shall include: location, depth and size of wellpoints, headers, sumps, ditches, size and location of discharge lines, capacities of pumps and standby units, and detailed description of dewatering methods to be employed to convey the water from site to adequate disposal.
 3. Include a written report outlining control procedures to be adopted if dewatering problem arises.
 4. Materials submitted shall be in a format acceptable for inclusion in required permit applications to any and all regulatory agencies for which permits for discharge water from the dewatering system are required due to the discharge reaching regulated bodies of water.
- C. Inspection Reports.
- D. All required permits.

PART 2 - PRODUCTS (NOT USED)

PART 3 - EXECUTION

3.1 INSTALLATION

- A. Install a dewatering system to lower and control ground surface water in order to permit excavation, construction of structure, and placement of backfill materials to be performed under dry conditions. Make the dewatering system adequate to pre-drain the water-bearing strata above and below the bottom of structure foundations, utilities and other excavations.
- B. In addition, reduce hydrostatic pressure head in water-bearing strata below structure foundations, utility lines, and other excavations, to extent that water levels in construction area are a minimum of 300 mm (1 foot) below prevailing excavation surface at all times.

3.2 OPERATION

- A. Prior to any excavation below the ground water table, place system into operation to lower water table as required and operate it continuously 24 hours a day, 7 days a week until utilities and structures have been satisfactorily constructed, which includes the placement of backfill materials and dewatering is no longer required.
- B. Place an adequate weight of backfill material to prevent buoyancy prior to discontinuing operation of the system.

3.3 WATER DISPOSAL

- A. Dispose of water removed from the excavations in such a manner as:
 - 1. Will not endanger portions of work under construction or completed.
 - 2. Will cause no inconvenience to the Owner or to others working near site.
 - 3. Will comply with the stipulations of required permits for disposal of water.
 - 4. Will Control Runoff: The Contractor shall be responsible for control of runoff in all work areas including but not limited to: excavations, access roads, parking areas, laydown, and staging areas. The Contractor shall provide, operate, and maintain all ditches, basins, sumps, culverts, site grading, and pumping facilities to divert, collect, and remove all water from the work areas. All water shall be removed from the immediate work areas and shall be disposed of in accordance with applicable permits.
- B. Excavation Dewatering:
 - 1. The Contractor shall be responsible for providing all facilities required to divert, collect, control, and remove water from all construction work areas and excavations.
 - 2. Drainage features shall have sufficient capacity to avoid flooding of work areas.
 - 3. Drainage features shall be so arranged and altered as required to avoid degradation of the final excavated surface(s).

4. The Contractor shall utilize all necessary erosion and sediment control measures as described herein to avoid construction related degradation of the natural water quality.

C. Dewatering equipment shall be provided to remove and dispose of all surface and ground water entering excavations, trenches, or other parts of the work during construction. Each excavation shall be kept dry during subgrade preparation and continually thereafter until the structure to be built, or the pipe to be installed therein, is completed to the extent that no damage from hydrostatic pressure, flotation, or other cause will result.

3.4 STANDBY EQUIPMENT

A. Provide complete standby equipment, installed and available for immediate operation, as may be required to adequately maintain de-watering on a continuous basis and in the event that all or any part of the system may become inadequate or fail.

3.5 CORRECTIVE ACTION

A. If dewatering requirements are not satisfied due to inadequacy or failure of the dewatering system (loosening of the foundation strata, or instability of slopes, or damage to foundations or structures), perform work necessary for reinstatement of foundation soil and damaged structure resulting from such inadequacy or failure by Contractor, at no additional cost to the Owner.

3.6 DAMAGES

A. Immediately repair damages to adjacent facilities caused by dewatering operations.

3.7 REMOVAL

A. Ensure compliance with all conditions of regulating permits and provide such information to the Engineer of Record. Obtain written approval from Engineer of Record before discontinuing operation of dewatering system.

END OF SECTION 312319

SECTION 316615 – HELICAL FOUNDATION PILES

1. GENERAL

1. RELATED DOCUMENTS

- A. Drawings and general provisions of the Contract, including General and Supplementary Conditions and Division 01 Specification Sections, apply to this Section. If differing requirements are identified elsewhere (in these specifications or on drawings or separate instructions), the more stringent requirement shall be met.

2. SUMMARY

- A. Section includes design, layout and staking, installation and testing of helical foundation piles.

3. UNIT PRICES

- A. Contract Sum: Base Contract Sum on number and dimensions of piles indicated from tip to cutoff, plus not less than 12 inches of overlength for cutting piles at cutoff elevations.

- B. Work of this Section is affected as follows:

- 1. Additional payment for pile lengths in excess of that indicated, and credit for pile lengths less than that indicated, is calculated at unit prices stated in the Contract, based on net addition or deduction to total pile length as determined by Architect and measured to nearest 12 inches.
 - a. Additional payment for splices required to extend pile lengths in excess of that indicated is calculated at unit prices stated in the Contract.
- 2. Additional payment for number of piles in excess of that indicated, and credit for number of piles less than that indicated, is calculated at unit prices stated in the Contract.
- 3. Unit prices include labor, materials, tools, equipment, and incidentals for furnishing, driving, cutting off, capping, and disposing of cutoffs.
- 4. Test piles that become part of permanent foundation system are considered as an integral part of the Work.
- 5. No payment is made for rejected piles, including piles driven out of tolerance, defective piles, or piles damaged during handling or driving.

- C. Load Test: At the discretion of the Engineer a load test may need to be performed in order to validate helical pier loading information. Provide a unit cost to perform a load test as outlined in section 3.6.

4. PREINSTALLATION MEETINGS

- A. Preinstallation Conference: Conduct conference at Project site.

5. PERFORMANCE REQUIREMENTS

- A. Design, furnish and install helical foundation piles capable of supporting design loads provided on the Drawings while limiting pile deflections to 1/2 inch or less.
1. Delegated Design: Design helical foundation piles, including comprehensive engineering analysis by a qualified professional engineer, using performance requirements and design criteria indicated.
 2. Design helical piers in accordance with Manufacturer's or ICCES requirements.
 3. Limit allowable axial design load of helical foundation piles in accordance with the current version of the Michigan Building Code.
 - a. Include down drag forces expected to result at the project site.
 - b. Conduct static pile load tests to supplement poorly well-documented correlations of ultimate pile capacity as a function of installation torque.
 4. Provide helical pier shafts (e.g. round shafts) capable of preventing buckling. Calculate critical axial (buckling) load using industry standard approved methods.
 5. Provide sacrificial steel and/or galvanization to provide a minimum helical foundation pile design life of 50 years.
 6. Rely only end bearing resistance of helices installed at least 5 feet below organic soils, soft to medium clays and other compressible soils.
 7. Size helical foundation pile attachment to grade beam, pile cap, etc. to limit concrete bearing stresses in accordance with ACI Building Code and the stresses in the steel plates/welds in accordance with AISC allowable stresses for steel members.

6. ACTION SUBMITTALS

- A. Qualification Data:
1. For qualified professional engineer.
 2. For qualified specialty contractor:
 - a. Provide lists of similar project completed with project names and addresses, names and address of the project-respective architects and owners, and other relevant information
 - b. Provide resumes of all field personnel assigned to the project along with the Project Foreman and Equipment Operator to be assigned to the project. The Contractor cannot substitute others for any of these individuals without written approval of the Architect or Owner.
- B. Delegated-Design Submittal: For helical foundation piles indicated to comply with performance requirements and design criteria, including analysis data signed and sealed by the qualified professional engineer responsible for their preparation.
- C. Shop Drawings: Submit to the Construction Manager for review and approval prior to beginning work.
1. Helical Pile number, location and pattern by assigned identification number.
 2. Helical Pile design load.
 3. Type and size of central steel shaft.
 4. Helix configuration (number and diameter of helix plates).
 5. Minimum effective installation torque.
 6. Minimum overall length.
 7. Inclination of Helical Pile.
 8. Cut-off elevation.
 9. Helical Pile attachment (to grade beam, pile cap, etc.) details.
 10. Corrosion protection details.

11. Installation sequence.
 12. Design load verification methods.
 13. Pile load testing.
- D. Product Data: Submit to the Construction Manager for review and approval prior to beginning work.
1. Helical foundation pile lead sections.
 2. Helical foundation pile extensions.
 3. Pile attachments.
 4. Mill Certificates for steel elements documenting:
 - a. Ultimate strength.
 - b. Yield strength.
 - c. Percent elongation.
 - d. Chemical composition.
 5. Calibration reports for testing equipment documenting: Equipment used must be have been calibrated within the previous six months
 - a. Name of project and Contractor.
 - b. Name of testing agency.
 - c. Identification (serial number) of device calibrated.
 - d. Description of calibrated testing equipment.
 - e. Date of calibration.
 - f. Calibration data.
- E. Installation Records: Submit to the Construction Manager weekly with:
1. Name of project and Contractor.
 2. Name of Contractor's supervisor during installation.
 3. Date and time of installation.
 4. Name and model of installation equipment.
 5. Type of torque indicator used.
 6. Location of Helical Pile by assigned identification number.
 7. Actual Helical Pile type and configuration – including lead section (number and size of helix plates), number and type of extension sections (manufacturer's SKU numbers).
 8. Helical Pile installation duration and observations.
 9. Total length of installed Helical Pile.
 10. Cut-off elevation.
 11. Inclination of Helical Pile.
 12. Installation torque at one-foot intervals for the final 10 feet.
 13. Comments pertaining to interruptions, obstructions, or other relevant information.
 14. Rated load capacities
- F. Pile Load Test Reports: Submit to the Construction Manager within 24 hours of completion of any pile load test documenting:
1. Name of project and Contractor.
 2. Name of Contractor's supervisor during installation.
 3. Name of third party test agency, if required.
 4. Date, time, and duration of test.
 5. Location of Helical Pile by assigned identification number.
 6. Type of test (i.e. tension or compression).
 7. Description of calibrated testing equipment and test set-up.
 8. Actual Helical Pile type and configuration – including lead section, number and type of extension sections (manufacturer's SKU numbers).
 9. Steps and duration of each load increment.
 10. Cumulative pile-head movement at each load step.

11. Comments pertaining to test procedure, equipment adjustments, or other relevant information.
12. Comments pertaining to test procedure, equipment adjustments, or other relevant information.

G. Closeout Documents: Submit to the Construction Manager prior to final payment:

1. Warranty: Warranty documents specified herein
 - a. Project Warranty: Refer to Conditions of the Contract for project warranty provisions.
 - b. Warranty Period: One year commencing on date of Substantial Completion.
 - c. Manufacturer's Warranty: Submit, for Owner's Acceptance, manufacturer's stand warranty document executed by authorized company official. Manufacturer's warranty is in addition to, and not a limitation of, other rights the Owner may have under Contract Document.
2. Helical Pier Foundation as-built drawings depicting as-installed pile locations and attachment details.

7. QUALITY ASSURANCE

- A. Demonstrate a minimum of five years experience designing and installing similar helical foundation piles.
- B. Helical foundation pile components shall be manufactured by a facility whose quality systems comply with ISO (International Organization of Standards) 9001 requirements. Certificates of Registration denoting ISO Standards Number shall be presented upon request to the Owner or their representative
- C. Independent Engineering Testing Agency: Construction Manager will retain to monitor installation of helical foundation piles and verify work is performed in accordance with approved submittals.
- D. Pre-Installation Conference: Conduct conference at the Project Site.
 1. Review methods and procedures related to helical foundation piles including, but not limited to, the following:
 - a. Geotechnical report.
 - b. Existing utilities and subsurface conditions.
 - c. Proposed helical foundation pile systems.
 - d. Proposed equipment, installation methods and verification tests.
 - e. Monitoring of helical foundation piles.
 - f. Coordination with pile cap (foundation) construction.

8. PROJECT CONDITIONS

- A. Project Site Information: A geotechnical report has been prepared for this Project and is available for information only. The opinions expressed in this report are those of geotechnical engineer and represent interpretations of subsoil conditions, tests, and results of analyses conducted by geotechnical engineer. Owner will not be responsible for interpretations or conclusions drawn from the data.

1. Make additional test borings and conduct other exploratory operations necessary for helical foundation piles.
2. The geotechnical report is included elsewhere in the Project Manual.

2.PRODUCTS

1. MATERIALS

- A. General: Provide materials that are new.
- B. Central Steel Shaft: The central steel shaft, consisting of lead sections, helical extensions, and plain extensions, shall be Type RS (Round Shaft) by outside diameter. Provide structural steel tube or pipe, seamless or straight-seam welded, shafts meeting ASTM A53, A252, ASTM A500, or ASTM A618 requirements.
- C. Helix Bearing Plates (Helices): Shall be hot rolled carbon steel sheet, strip, or plate formed on matching metal dies to true helical shape and uniform pitch. Provide bearing plate materials meeting ASTM A36, A572, A656 or A1018 requirements.
- D. Bolts: The size and type of bolts used to connect the central steel shaft sections together shall conform to manufactures recommendations. Provide bolts meeting SAE J429 Grade 5 or 8 requirements.
- E. Couplings: Couplings shall either be formed as an integral part of the plain and helical extension material as hot forge expanded sockets, or as internal sleeve wrought steel connectors. The steel connectors can be either tubing or solid steel bar with holes for connecting shaft sections together.
- F. Plates, Shapes or Pile Caps: Depending on the application, the pile cap shall be a welded assembly consisting of structural steel plates and shapes designed to fit the pile and transfer the applied load. Structural steel plates and shapes for helical foundation pile top attachments shall conform to ASTM A36 or ASTM A572 Grade 50.
- G. Corrosion Protection: Provide hot-dipped galvanized in accordance with ASTM A153 after fabrication.
- H. Welding: AWS D1.1 code, for welding in building construction.

3.EXECUTION

1. PREPARATION

- A. Prepare to install helical foundation piles within excavations extending down to bottom of grade beam, pile cap, etc.
- B. Inspect the work of all other trades and verify that work of other trades is completed to the point where installation of helical foundation piles may commence without restriction.

2. INSTALLATION EQUIPMENT

- A. Shall be rotary type, hydraulic power driven torque motor with clockwise and counter-clockwise rotation capabilities. The torque motor shall be capable of continuous adjustment to revolutions per minute (RPM's) during installation. Percussion drilling equipment shall not be permitted. The torque motor shall have torque capacity 15% greater than the torsional strength rating of the central steel shaft to be installed.
- B. Equipment shall be capable of applying adequate down pressure (crowd) and torque simultaneously to suit project soil conditions and load requirements. The equipment shall be capable of continuous position adjustment to maintain proper Helical Pile alignment.

3. INSTALLATION TOOLING

- A. Shall consist of a Kelly Bar Adapter (KBA) drive tools as manufactured by the Helical Pile manufacturer and used in accordance with the manufacturer's written installation instructions.
- B. Installation tooling should be maintained in good working order and safe to operate at all times. Flange bolts and nuts should be regularly inspected for proper tightening torque. Bolts, connecting pins, and retainers should be periodically inspected for wear and/or damage and replaced with identical items provided by the manufacturer. Heed all warning labels. Worn or damaged tooling should be replaced.
- C. A torque indicator shall be used during Helical Pile installation. The torque indicator can be an integral part of the installation equipment or externally mounted in-line with the installation tooling.
- D. Shall be capable of providing continuous measurement of applied torque throughout the installation.
- E. Shall be capable of torque measurements in increments of at least 500 ft-lb
- F. Shall be calibrated prior to pre-production testing or start of work. Torque indicators which are an integral part of the installation equipment, shall be calibrated on-site. Torque indicators which are mounted in-line with the installation tooling, shall be calibrated either on-site or at an appropriately equipped test facility. Indicators that measure torque as a function of hydraulic pressure shall be calibrated at normal operating temperatures.
- G. Shall be re-calibrated, if in the opinion of the Owner and/or Contractor reasonable doubt exists as to the accuracy of the torque measurements.

4. INSTALLATION PROCEDURES

- A. Central Steel Shaft: (Lead and Extension Sections)
 - 1. The Helical Pile installation technique shall be such that it is consistent with the geotechnical, logistical, environmental, and load carrying conditions of the project.
 - 2. The lead section shall be positioned at the location as shown on the working drawings. Battered Helical Piles can be positioned perpendicular to the ground to assist in initial advancement into the soil before the required batter angle shall be established. The Helical Pile sections shall be engaged and advanced into the soil in a smooth, continuous manner at a rate of rotation of 5 to 20 RPM's. Extension sections shall be provided to

obtain the required minimum overall length and installation torque as shown on the working drawings. Connect sections together using coupling bolt(s) and nut torqued to 40 ft-lb.

3. Sufficient down pressure shall be applied to uniformly advance the Helical Pile sections approximately 3 inches per revolution. The rate of rotation and magnitude of down pressure shall be adjusted for different soil conditions and depths.

5. TERMINATION CRITERIA

- A. The torque as measured during the installation shall not exceed the torsional strength rating of the central steel shaft.
- B. The minimum installation torque and minimum overall length criteria as shown on the working drawings shall be satisfied prior to terminating the Helical Pile installation.
- C. If the torsional strength rating of the central steel shaft and/or installation equipment has been reached prior to achieving the minimum overall length required, the Contractor shall have the following options:
 1. Terminate the installation at the depth obtained subject to the review and acceptance of the Owner, or:
 2. Remove the existing Helical Pile and install a new one with fewer and/or smaller diameter helix plates. The new helix configuration shall be subject to review and acceptance of the Owner. If re-installing in the same location, the top-most helix of the new Helical Pile shall be terminated at least (3) three feet beyond the terminating depth of the original Helical Pile.
 3. It is generally not recommended to re-use Type RS Helical Pile shaft material after the coupling bolt holes have been noticeably elongated during a previous installation.
 4. If the minimum installation torque as shown on the working drawings is not achieved at the minimum overall length, and there is no maximum length constraint, the Contractor shall have the following options:
 - a. Install the Helical Pile deeper using additional extension sections, or:
 - b. Remove the existing Helical Pile and install a new one with additional and/or larger diameter helix plates. The new helix configuration shall be subject to review and acceptance of the Owner. If re-installing in the same location, the top-most helix of the new Helical Pile shall be terminated at least (3) three feet beyond the terminating depth of the original Helical Pile.
 - c. De-rate the load capacity of the Helical Pile and install additional Helical Pile(s). The de-rated capacity and additional Helical Pile location shall be subject to the review and acceptance of the Owner.
 5. If the Helical Pile is refused or deflected by a subsurface obstruction, the installation shall be terminated and the pile removed. The obstruction shall be removed, if feasible, and the Helical Pile re-installed. If the obstruction can't be removed, the Helical Pile shall be installed at an adjacent location, subject to review and acceptance of the Owner.
 6. If the torsional strength rating of the central steel shaft and/or installation equipment has been reached prior to proper positioning of the last plain extension section relative to the final elevation, the Contractor may remove the last plain extension and replace it with a shorter length extension. If it is not feasible to remove the last plain extension, the Contractor may cut said extension shaft to the correct elevation. The Contractor shall not reverse (back-out) the Helical Pile to facilitate extension removal.
 7. The average torque for the last three feet of penetration shall be used as the basis of comparison with the minimum installation torque as shown on the working drawings.

The average torque shall be defined as the average of the last three readings recorded at one-foot intervals.

8. The average torque can be empirically related to the Helical Pile's ultimate capacity in end-bearing. This well-known attribute of helical piles can be used as a production control method to indicate the Helical Pile's end-bearing capacity.

6. PILE LOAD TESTS

- A. Perform pile load tests as required to demonstrate correlations between installation torque and ultimate helical foundation pile axial capacity.
- B. Perform load test in accordance with ASTM D1143, Standard Test Method for Piles Under Static Axial Compressive Load.
- C. Submit load testing procedures and acceptance criteria prior to performing load tests.

7. TOLERANCES

- A. Maximum Variation from Vertical: as allowed by engineer responsible for design of helical piles.
- B. Maximum Variation From Design Top Elevation: +0 inches/-1 inch.
- C. Maximum Out-of-Position: as allowed by engineer responsible for design of helical piles.

END OF SECTION 316615

SECTION 320523 - CEMENT AND CONCRETE FOR EXTERIOR IMPROVEMENTS

PART 1 - GENERAL

1.1 DESCRIPTION

- A. This section shall cover site work concrete constructed upon the prepared subgrade and in conformance with the lines, grades, thickness, and cross sections shown. Construction shall include the following:
- B. Curb and gutter.
- C. Pedestrian Pavement: Walks, grade slabs, crossings, wheelchair curb ramps, and steps.
- D. Vehicular Pavement: driveways.
- E. Equipment Pads: Transformers.

1.2 RELATED WORK

- A. Subgrade Preparation: Section 312000, EARTH MOVING.
- B. Concrete Materials, Quality, Mixing, Design and Other Requirements: Section 033000, CAST-IN-PLACE-CONCRETE.

1.3 DESIGN REQUIREMENTS

- A. Design all elements with the latest published version of applicable codes.

1.4 WEATHER LIMITATIONS

- A. Placement of concrete shall be as specified under Article 3.8, COLD WEATHER and Article 3.7, HOT WEATHER of Section 033000, CAST-IN-PLACE CONCRETE.

1.5 SUBMITTALS

- A. In accordance with Section 013000, ADMINISTRATIVE REQUIREMENTS, furnish the following:
- B. Manufacturers' Certificates and Data certifying that the following materials conform to the requirements specified.
 - 1. Expansion joint filler

2. Hot poured sealing compound
3. Reinforcement
4. Curing materials

C. Data and Test Reports: Select subbase material.

1. Job-mix formula.
2. Source, gradation, liquid limit, plasticity index, percentage of wear, and other tests as specified and in referenced publications.

1.6 APPLICABLE PUBLICATIONS

A. The publications listed below form a part of this specification to the extent referenced. The publications are referenced in the text by the basic designation only. Refer to the latest edition of all referenced Standards and codes.

B. American Association of State Highway and Transportation Officials (AASHTO):

- M031MM031-07-UL..... Deformed and Plain Carbon-Steel Bars for Concrete Reinforcement (ASTM A615/A615M-09)
- M055MM055-09-UL..... Steel Welded Wire Reinforcement, Plain, for Concrete (ASTM A185)
- M147-65-UL Materials for Aggregate and Soil-Aggregate Subbase, Base and Surface Courses (R 2004)
- M148-05-UL Liquid Membrane-Forming Compounds for Curing Concrete (ASTM C309)
- M171-05-UL Sheet Materials for Curing Concrete (ASTM C171)
- M182-05-UL Burlap Cloth Made from Jute or Kenaf and Cotton Mats
- M213-01-UL Preformed Expansion Joint Fillers for Concrete Paving and Structural Construction (Non-extruding and Resilient Bituminous Type) (ASTM D1751)
- M233-86-UL Boiled Linseed Oil Mixer for Treatment of Portland Cement Concrete
- T099-09-UL Moisture-Density Relations of Soils Using a 2.5 kg. (5.5 lb) Rammer and a 305 mm (12 in.) Drop
- T180-09-UL Moisture-Density Relations of Soils Using a 4.54 kg (10 lb.) Rammer and a 457 mm (18 in.) Drop

C. American Society for Testing and Materials (ASTM):
C94/C94M-09..... Ready-Mixed Concrete

C143/C143M-09 Slump of Hydraulic Cement Concrete

PART 2 - PRODUCTS

2.1 GENERAL

- A. Concrete shall be Type C, air-entrained as specified in Section 033000, CAST-IN-PLACE CONCRETE, with the following exceptions:

<u>TYPE</u>	<u>MAXIMUM SLUMP*</u>
Curb & Gutter	75 mm (3")
Pedestrian Pavement	75 mm (3")
Vehicular Pavement	50 mm (2") (Machine Finished) 100 mm (4") (Hand Finished)
Equipment Pad	75 to 100 mm (3" to 4")
* For concrete to be vibrated: Slump as determined by ASTM C143. Tolerances as established by ASTM C94.	

2.2 REINFORCEMENT

- A. The type, amount, and locations of steel reinforcement shall be as shown on the drawings and in the specifications.
- B. Welded wire-fabric shall conform to AASHTO M55.
- C. Dowels shall be plain steel bars conforming to AASHTO M31. Tie bars shall be deformed steel bars conforming to AASHTO M31.

2.3 SELECT SUBBASE (WHERE REQUIRED)

- A. Subbase material shall consist of select granular material composed of sand, sand-gravel, crushed stone, crushed or granulated slag, with or without soil binder, or combinations of these materials conforming to AASHTO M147, Grading E or F.
- B. Materials meeting other gradations than that noted will be acceptable whenever the gradations are within a tolerance of three to five percent, plus or minus, of the single gradation established by the job-mix formula.
- C. Subbase material shall produce a compacted, dense-graded course, meeting the density requirement specified herein.

2.4 FORMS

- A. Use metal or wood forms that are straight and suitable in cross-section, depth, and strength to resist springing during depositing and consolidating the concrete, for the work involved.
- B. Do not use forms if they vary from a straight line more than 3 mm (1/8 inch) in any 3000 mm (ten foot) long section, in either a horizontal or vertical direction.
- C. Wood forms should be at least 50 mm (2 inches) thick (nominal). Wood forms shall also be free from warp, twist, loose knots, splits, or other defects. Use approved flexible or curved forms for forming radii.

2.5 CONCRETE CURING MATERIALS

- A. Concrete curing materials shall conform to one of the following:
 - 1. Burlap conforming to AASHTO M182 having a weight of 233 grams (seven ounces) or more per square meter (yard) when dry.
 - 2. Impervious Sheeting conforming to AASHTO M171.
 - 3. Liquid Membrane Curing Compound conforming to AASHTO M148 (ASTM C309), Type 1 and shall be free of paraffin or petroleum.

2.6 EXPANSION JOINT FILLERS

- A. Material shall conform to AASHTO M213.

PART 3 - EXECUTION

3.1 SUBGRADE PENETRATION

- A. Prepare, construct, and finish the subgrade as specified in Section 312000, EARTH MOVING.
- B. Maintain the subgrade in a smooth, compacted condition, in conformance with the required section and established grade until the succeeding operation has been accomplished.

3.2 SELECT SUBBASE (WHERE REQUIRED)

- A. Mixing: Proportion the select subbase by weight or by volume in quantities so that the final approved job-mixed formula gradation, liquid limit, and plasticity index requirements will be met after subbase course has been placed and compacted. Add water in approved quantities, measured by weight or volume, in such a manner to produce a uniform blend.

B. Placing:

1. Place the mixed material on the prepared subgrade in a uniform layer to the required contour and grades, and to a loose depth not to exceed 200 mm (8 inches), and that when compacted, will produce a layer of the designated thickness.
2. When the designated compacted thickness exceeds 150 mm (6 inches), place the material in layers of equal thickness. Remove unsatisfactory areas and replace with satisfactory mixture, or mix the material in the area.
3. In no case will the addition of thin layers of material be added to the top layer in order to meet grade.
4. If the elevation of the top layer is 13 mm (1/2 inch) or more below the grade, excavate the top layer and replace with new material to a depth of at least 75 mm (3 inches) in compacted thickness.

C. Compaction:

1. Perform compaction with approved equipment (hand or mechanical) well suited to the material being compacted.
2. Moisten or aerate the material as necessary to provide the moisture content that will readily facilitate obtaining the specified compaction with the equipment used.
3. Compact each layer to at least 95 percent or 100 percent of maximum density as determined by AASHTO T180 or AASHTO T99 respectively.

D. Smoothness Test and Thickness Control:

Test the completed subbase for grade and cross section with a straight edge.

1. The surface of each layer shall not show any deviations in excess of 10 mm (3/8 inch).
2. The completed thickness shall be within 13 mm (1/2 inch) of the thickness as shown.

E. Protection:

1. Maintain the finished subbase in a smooth and compacted condition until the concrete has been placed.
2. When Contractor's subsequent operations or adverse weather disturbs the approved compacted subbase, excavate, and reconstruct it with new material meeting the requirements herein specified, at no additional cost to the Owner.

3.3 SETTING FORMS

A. Base Support:

1. Compact the base material under the forms true to grade so that, when set, they will be uniformly supported for their entire length at the grade as shown.
2. Correct imperfections or variations in the base material grade by cutting or filling and compacting.

B. Form Setting:

1. Set forms sufficiently in advance of the placing of the concrete to permit the performance and approval of all operations required with and adjacent to the form lines.
 2. Set forms to true line and grade and use stakes, clamps, spreaders, and braces to hold them rigidly in place so that the forms and joints are free from play or movement in any direction.
 3. Forms shall conform to line and grade with an allowable tolerance of 3 mm (1/8 inch) when checked with a straightedge and shall not deviate from true line by more than 6 mm (1/4 inch) at any point.
 4. Do not remove forms until removal will not result in damaged concrete or at such time to facilitate finishing.
 5. Clean and oil forms each time they are used.
- C. The Contractor's Registered Professional Land Surveyor shall establish and control the alignment and the grade elevations of the forms or concrete slipforming machine operations.
1. Make necessary corrections to forms immediately before placing concrete.
 2. When any form has been disturbed or any subgrade or subbase has become unstable, reset and recheck the form before placing concrete.

3.4 EQUIPMENT

- A. The Engineer of Record shall approve equipment and tools necessary for handling materials and performing all parts of the work prior to commencement of work.
- B. Maintain equipment and tools in satisfactory working condition at all times.

3.5 PLACING REINFORCEMENT

- A. Reinforcement shall be free from dirt, oil, rust, scale or other substances that prevent the bonding of the concrete to the reinforcement.
- B. Before the concrete is placed, the Engineer of Record shall approve the reinforcement, which shall be accurately and securely fastened in place with suitable supports and ties. The type, amount, and position of the reinforcement shall be as shown.

3.6 PLACING CONCRETE - GENERAL

- A. Obtain approval of the Engineer of Record before placing concrete.
- B. Remove debris and other foreign material from between the forms before placing concrete. Obtain approval of the Engineer of Record before placing concrete.
- C. Before the concrete is placed, uniformly moisten the subgrade, base, or subbase appropriately, avoiding puddles of water.

- D. Convey concrete from mixer to final place of deposit by a method which will prevent segregation or loss of ingredients. Deposit concrete so that it requires as little handling as possible.
- E. While being placed, spade or vibrate and compact the concrete with suitable tools to prevent the formation of voids or honeycomb pockets. Vibrate concrete well against forms and along joints. Over-vibration or manipulation causing segregation will not be permitted. Place concrete continuously between joints without bulkheads.
- F. Install a construction joint whenever the placing of concrete is suspended for more than 30 minutes and at the end of each day's work.
- G. Workmen or construction equipment coated with foreign material shall not be permitted to walk or operate in the concrete during placement and finishing operations.

3.7 PLACING CONCRETE FOR CURB AND GUTTER, PEDESTRIAN PAVEMENT, AND EQUIPMENT PADS

- A. Place concrete in the forms in one layer of such thickness that, when compacted and finished, it will conform to the cross section as shown.
- B. Deposit concrete as near to joints as possible without disturbing them but do not dump onto a joint assembly.
- C. After the concrete has been placed in the forms, use a strike-off guided by the side forms to bring the surface to the proper section to be compacted.
- D. Consolidate the concrete thoroughly by tamping and spading, or with approved mechanical finishing equipment.
- E. Finish the surface to grade with a wood or metal float.
- F. All Concrete pads and pavements shall be constructed with sufficient slope to drain properly.

3.8 PLACING CONCRETE FOR VEHICULAR PAVEMENT

- A. Deposit concrete into the forms as close as possible to its final position.
- B. Place concrete rapidly and continuously between construction joints.
- C. Strike off concrete and thoroughly consolidate by a finishing machine, vibrating screed, or by hand-finishing.
- D. Finish the surface to the elevation and crown as shown.
- E. Deposit concrete as near the joints as possible without disturbing them but do not dump onto a joint assembly. Do not place adjacent lanes without approval by the Engineer of Record.

3.9 CONCRETE FINISHING - GENERAL

- A. The sequence of operations, unless otherwise indicated, shall be as follows:
 - 1. Consolidating, floating, straight-edging, troweling, texturing, and edging of joints.
 - 2. Maintain finishing equipment and tools in a clean and approved condition.

3.10 CONCRETE FINISHING - CURB AND GUTTER

- A. Round the edges of the gutter and top of the curb with an edging tool to a radius of 6mm (1/4 inch) or as otherwise detailed.
- B. Float the surfaces and finish with a smooth wood or metal float until true to grade and section and uniform in textures.
- C. Finish the surfaces, while still wet, with a bristle type brush with longitudinal strokes.
- D. Immediately after removing the front curb form, rub the face of the curb with a wood or concrete rubbing block and water until blemishes, form marks, and tool marks have been removed. Brush the surface, while still wet, in the same manner as the gutter and curb top.
- E. Except at grade changes or curves, finished surfaces shall not vary more than 3 mm (1/8 inch) for gutter and 6 mm (1/4 inch) for top and face of curb, when tested with a 3000 mm (10 foot) straightedge.
- F. Remove and reconstruct irregularities exceeding the above for the full length between regularly scheduled joints.
- G. Correct any depressions which will not drain.
- H. Visible surfaces and edges of finished curb, gutter, and combination curb and gutter shall be free of blemishes, form marks, and tool marks, and shall be uniform in color, shape, and appearance.

3.11 CONCRETE FINISHING PEDESTRIAN PAVEMENT

- A. Walks, Grade Slabs, Wheelchair Curb Ramps, :
 - 1. Finish the surfaces to grade and cross section with a metal float, trowled smooth and finished with a broom moistened with clear water.
 - 2. Brooming shall be transverse to the line of traffic.
 - 3. Finish all slab edges, including those at formed joints, carefully with an edger having a radius as shown on the Drawings.
 - 4. Unless otherwise indicated, edge the transverse joints before brooming. The brooming shall eliminate the flat surface left by the surface face of the edger. Execute the brooming so that the corrugation, thus produced, will be uniform in appearance and not more than 2 mm (1/16 inch) in depth.

5. The completed surface shall be uniform in color and free of surface blemishes, form marks, and tool marks. The finished surface of the pavement shall not vary more than 5 mm (3/16 inch) when tested with a 3000 mm (10 foot) straightedge.
6. The thickness of the pavement shall not vary more than 6 mm (1/4 inch).
7. Remove and reconstruct irregularities exceeding the above for the full length between regularly scheduled joints.

3.12 CONCRETE FINISHING FOR VEHICULAR PAVEMENT

- A. Accomplish longitudinal floating with a longitudinal float not less than 3000 mm (10 feet) long and 150 mm (6 inches) wide, properly stiffened to prevent flexing and warping. Operate the float from foot bridges in a sawing motion parallel to the direction in which the pavement is being laid from one side of the pavement to the other, and advancing not more than half the length of the float.
- B. After the longitudinal floating is completed, but while the concrete is still plastic, eliminate minor irregularities in the pavement surfaces by means of metal floats, 1500 mm (5 feet) in length, and straightedges, 3000 mm (10 feet) in length. Make the final finish with the straightedges, which shall be used to float the entire pavement surface.
- C. Test the surface for trueness with a 3000 mm (10 foot) straightedge held in successive positions parallel and at right angles to the direction in which the pavement is being laid and the entire area covered as necessary to detect variations. Advance the straightedge along the pavement in successive stages of not more than one half the length of the straightedge. Correct all irregularities and refinish the surface.
- D. The finished surface of the pavement shall not vary more than 6 mm (1/4 inch) in both longitudinal and transverse directions when tested with a 3000 mm (10 foot) straightedge.
- E. The thickness of the pavement shall not vary more than 6 mm (1/4 inch).
- F. When most of the water glaze or sheen has disappeared and before the concrete becomes nonplastic, give the surface of the pavement a broomed finish with an approved fiber broom not less than 450 mm (18 inches) wide. Pull the broom gently over the surface of the pavement from edge to edge. Brooming shall be transverse to the line of traffic and so executed that the corrugations thus produced will be uniform in character and width, and not more than 3 mm (1/8 inch) in depth. Carefully finish the edge of the pavement along forms and at the joints with an edging tool. The brooming shall eliminate the flat surface left by the surface face of the edger.
- G. The finish surfaces of new and existing abutting pavements shall coincide at their juncture.

3.13 CONCRETE FINISHING EQUIPMENT PADS

- A. After the surface has been struck off and screeded to the proper elevation, give it a smooth dense float finish, free from depressions or irregularities.
- B. Carefully finish all slab edges with an edger having a radius as shown in the Drawings.

- C. After removing the forms, rub the faces of the pad with a wood or concrete rubbing block and water until blemishes, form marks, and tool marks have been removed. The finish surface of the pad shall not vary more than 3 mm (1/8 inch) when tested with a 3000 mm (10 foot) straightedge.
- D. Correct irregularities exceeding the above.

3.14 JOINTS - GENERAL

- A. Place joints, where shown, conforming to the details as shown, and perpendicular to the finished grade of the concrete surface.
- B. Joints shall be straight and continuous from edge to edge of the pavement.

3.15 CONTRACTION JOINTS

- A. Cut joints to depth as shown with a grooving tool or jointer of a radius as shown or by sawing with a blade producing the required width and depth.
- B. Construct joints in curbs and gutters by inserting 3 mm (1/8 inch) steel plates conforming to the cross sections of the curb and gutter.
- C. Plates shall remain in place until concrete has set sufficiently to hold its shape and shall then be removed.
- D. Finish edges of all joints with an edging tool having the radius as shown.
- E. Score pedestrian pavement with a standard grooving tool or jointer.

3.16 EXPANSION JOINTS

- A. Use a preformed expansion joint filler material of the thickness as shown to form expansion joints.
- B. Material shall extend the full depth of concrete, cut and shaped to the cross section as shown, except that top edges of joint filler shall be below the finished concrete surface where shown to allow for sealing.
- C. Anchor with approved devices to prevent displacing during placing and finishing operations.
- D. Round the edges of joints with an edging tool.
- E. Form expansion joints as follows:
 - 1. Without dowels, about structures and features that project through, into, or against any site work concrete construction.
 - 2. Using joint filler of the type, thickness, and width as shown.

3. Installed in such a manner as to form a complete, uniform separation between the structure and the site work concrete item.

3.17 CONSTRUCTION JOINTS

- A. Locate longitudinal and transverse construction joints between slabs of vehicular pavement as shown.
- B. Place transverse construction joints of the type shown, where indicated and whenever the placing of concrete is suspended for more than 30 minutes.
- C. Use a butt-type joint with dowels in curb and gutter if the joint occurs at the location of a planned joint.

3.18 FORM REMOVAL

- A. Forms shall remain in place at least 12 hours after the concrete has been placed. Remove forms without injuring the concrete.
- B. Do not use bars or heavy tools against the concrete in removing the forms. Promptly repair any concrete found defective after form removal.

3.19 CURING OF CONCRETE

- A. Cure concrete by one of the following methods appropriate to the weather conditions and local construction practices, against loss of moisture, and rapid temperature changes for at least seven days from the beginning of the curing operation. Protect unhardened concrete from rain and flowing water. All equipment needed for adequate curing and protection of the concrete shall be on hand and ready to install before actual concrete placement begins. Provide protection as necessary to prevent cracking of the pavement due to temperature changes during the curing period. If any selected method of curing does not afford the proper curing and protection against concrete cracking, remove and replace the damaged pavement and employ another method of curing as directed by the Engineer of Record.
- B. Burlap Mat: Provide a minimum of two layers kept saturated with water for the curing period. Mats shall overlap each other at least 150 mm (6 inches).
- C. Impervious Sheeting: Use waterproof paper, polyethylene-coated burlap, or polyethylene sheeting. Polyethylene shall be at least 0.1 mm (4 mils) in thickness. Wet the entire exposed concrete surface with a fine spray of water and then cover with the sheeting material. Sheets shall overlap each other at least 300 mm (12 inches). Securely anchor sheeting.
- D. Liquid Membrane Curing:

1. Apply pigmented membrane-forming curing compound in two coats at right angles to each other at a rate of 5 m²/L (200 square feet per gallon) for both coats.
2. Do not allow the concrete to dry before the application of the membrane.
3. Cure joints designated to be sealed by inserting moistened paper or fiber rope or covering with waterproof paper prior to application of the curing compound, in a manner to prevent the curing compound entering the joint.
4. Immediately re-spray any area covered with curing compound and damaged during the curing period.

3.20 CLEANING

A. After completion of the curing period:

1. Remove the curing material (other than liquid membrane).
2. Sweep the concrete clean.
3. After removal of all foreign matter from the joints, seal joints as herein specified.
4. Clean the entire concrete of all debris and construction equipment as soon as curing and sealing of joints has been completed.

3.21 PROTECTION

A. The contractor shall protect the concrete against all damage prior to final acceptance by the Owner. Remove concrete containing excessive cracking, fractures, spalling, or other defects and reconstruct the entire section between regularly scheduled joints, when directed by the Engineer of Record, and at no additional cost to the Owner. Exclude traffic from vehicular pavement until the concrete is at least seven days old, or for a longer period of time if so directed by the Engineer of Record.

3.22 FINAL CLEAN-UP

A. Remove all debris, rubbish and excess material from the site.

END OF SECTION 320523

SECTION 321216 – ASPHALT PAVING

PART 1 - GENERAL

1.1 DESCRIPTION

- A. This work shall cover the composition, mixing, construction upon the prepared subgrade, and the protection of hot asphalt concrete pavement. The hot asphalt concrete pavement shall consist of an aggregate or asphalt base course and asphalt surface course constructed in conformity with the lines, grades, thickness, and cross sections as shown. Each course shall be constructed to the depth, section, or elevation required by the drawings and shall be rolled, finished, and approved before the placement of the next course.

1.2 RELATED WORK

- A. Subgrade Preparation: Paragraph 3.3 and Section 312000, EARTH MOVING.

1.3 INSPECTION OF PLANT AND EQUIPMENT

- A. The Engineer of Record shall have access at all times to all parts of the material producing plants for checking the mixing operations and materials and the adequacy of the equipment in use.

1.4 ALIGNMENT AND GRADE CONTROL

- A. The Contractor's Registered Professional Land Surveyor shall establish and control the pavement (aggregate or asphalt base course and asphalt surface course) alignments, grades, elevations, and cross sections as shown on the Drawings.

1.5 SUBMITTALS

- A. In accordance with Section 013000, ADMINISTRATIVE REQUIREMENTS, furnish the following:
 - B. Data and Test Reports:
 - 1. Aggregate Base Course: Sources, gradation, liquid limit, plasticity index, percentage of wear, and other tests required by MDOT.
 - 2. Asphalt Base/Surface Course: Aggregate source, gradation, soundness loss, percentage of wear, and other tests required by MDOT.
 - 3. Job-mix formula.

C. Certifications:

1. Asphalt prime and tack coat material certificate of conformance to MDOT requirements.
2. Asphalt cement certificate of conformance to MDOT requirements.
3. Job-mix certification - Submit plant mix certification that mix equals or exceeds the MDOT Specification.

D. One copy of MDOT Specifications.

E. Provide MSDS (Material Safety Data Sheets) for all chemicals used on ground.

PART 2 - PRODUCTS

2.1 GENERAL

- A. Aggregate base, Asphaltic base and asphalt concrete materials shall conform to the requirements of the following and other appropriate sections of the latest version of the MDOT Material Specifications, including amendments, addenda and errata. Where the term "Engineer" or "Commission" is referenced in the MDOT Specifications, it shall mean the Engineer of Record.

2.2 AGGREGATES

- A. Provide aggregates consisting of crushed stone, gravel, sand, or other sound, durable mineral materials processed and blended, and naturally combined.
- B. Subbase aggregate (where required) MDOT Class II material.

2.3 HOT MIX ASPHALTS

- A. Comply with provisions of Asphalt Institute Specification SS2:

1. Asphalt cement: Penetration grade 64-22
2. Prime coat: Cut-back type, grade MC-250
3. Tack coat: Uniformly emulsified, grade SS-1H

B. Mix Designs:

1. Bituminous Base Course: MDOT #3C Asphalt
2. Bituminous Wearing Course: MDOT 5E-1 Asphalt

PART 3 - EXECUTION

3.1 GENERAL

- A. The Asphalt Concrete Paving equipment, weather limitations, job-mix formula, mixing, construction methods, compaction, finishing, tolerance, and protection shall conform to the requirements of the appropriate sections of the MDOT Specifications for the type of material specified.

3.2 MIXING ASPHALTIC CONCRETE MATERIALS

- A. Provide hot plant-mixed asphaltic concrete paving materials.
 - 1. Temperature leaving the plant: 143 degrees C(290 degrees F) minimum, 160 degrees C(320 degrees F) maximum.
 - 2. Temperature at time of placing: 138 degrees C(280 degrees F) minimum.

3.3 SUBGRADE

- A. Shape to line and grade and compact with self-propelled rollers.
- B. All depressions that develop under rolling shall be filled with acceptable material and the area re-rolled.
- C. Soft areas shall be removed and filled with acceptable materials and the area re-rolled.
- D. Should the subgrade become rutted or displaced prior to the placing of the subbase, it shall be reworked to bring to line and grade.
- E. Proof-roll the subgrade with maximum 45 tonne (50 ton) gross weight dump truck as directed by the Engineer of Record. If pumping, pushing, or other movement is observed, rework the area to provide a stable and compacted subgrade.

3.4 BASE COURSES

- A. Subbase (when required)
 - 1. Spread and compact to the thickness shown on the drawings.
 - 2. Rolling shall begin at the sides and continue toward the center and shall continue until there is no movement ahead of the roller.
 - 3. After completion of the subbase rolling there shall be no hauling over the subbase other than the delivery of material for the top course.
- B. Base
 - 1. Spread and compact to the thickness shown on the drawings.

2. Rolling shall begin at the sides and continue toward the center and shall continue until there is no movement ahead of the roller.
 3. After completion of the base rolling there shall be no hauling over the base other than the delivery of material for the top course.
- C. Thickness tolerance: Provide the compacted thicknesses shown on the Drawings within a tolerance of minus 0.0" to plus 0.25".
- D. Smoothness tolerance: Provide the lines and grades shown on the Drawings within a tolerance of 3/16 inch in ten feet.
- E. Moisture content: Use only the amount of moisture needed to achieve the specified compaction.

3.5 PLACEMENT OF ASPHALTIC CONCRETE PAVING

- A. Remove all loose materials from the compacted base.
- B. Apply the specified prime coat, and tack coat where required, and allow to dry in accordance with the manufacturer's recommendations as approved by the Architect or Engineer.
- C. Receipt of asphaltic concrete materials:
1. Do not accept material unless it is covered with a tarpaulin until unloaded, and unless the material has a temperature of not less than 130 degrees C(280 degrees F).
 2. Do not commence placement of asphaltic concrete materials when the atmospheric temperature is below 10 degrees C (50 degrees F), not during fog, rain, or other unsuitable conditions.
- D. Spreading:
1. Spread material in a manner that requires the least handling.
 2. Where thickness of finished paving will be 3" or less, spread in one layer.
- E. Rolling:
1. After the material has been spread to the proper depth, roll until the surface is hard, smooth, unyielding, and true to the thickness and elevations shown on the drawings.
 2. Roll in at least two directions until no roller marks are visible.
 3. Finished paving smoothness tolerance:
 - a. No depressions which will retain standing water.
 - b. No deviation greater than 1/8" in six feet.

3.6 APPLICATION OF SEAL COAT

- A. Prepare the surfaces, mix the seal coat material, and apply in accordance with the manufacturer's recommendations as approved by the Architect or Engineer.

- B. Apply one coat of the specified sealer.
- C. Achieve a finished surface seal which, when dry and thoroughly set, is smooth, tough, resilient, of uniform black color, and free from coarse textured areas, lap marks, ridges, and other surface irregularities.

3.7 PROTECTION

- A. Protect the asphaltic concrete paved areas from traffic until the sealer is set and cured and does not pick up under foot or wheeled traffic.

3.8 FINAL CLEAN-UP

- A. Remove all debris, rubbish, and excess material from the work area.

END OF SECTION 321216

SECTION 321723 - PAVEMENT MARKINGS

PART 1 - GENERAL

1.1 SUMMARY

- A. Section includes painted markings applied to asphalt and concrete pavement.

1.2 PREINSTALLATION MEETINGS

- A. Preinstallation Conference: Conduct conference at Project site.

1.3 ACTION SUBMITTALS

- A. Product Data: For each type of product.
- B. Samples: For each exposed product and for each color and texture specified.

PART 2 - PRODUCTS

2.1 MANUFACTURERS

- A. Manufacturers: Subject to compliance with requirements, available manufacturers offering products that may be incorporated into the Work include, but are not limited to, the following:
- B. Basis-of-Design Product: Subject to compliance with requirements, provide parking lot pavement marking paint, by one of the following:
 - 1. Aexcel Inc.
 - 2. Benjamin Moore & Co.
 - 3. Color Wheel Paints & Coatings.
 - 4. Columbia Paint & Coatings.
 - 5. Conco Paints.
 - 6. Coronado Paint; Division of INSL-X Products Corporation.
 - 7. Diamond Vogel Paints.
 - 8. Dunn-Edwards Corporation.

9. Ennis Traffic Safety Solutions, Inc.
10. Frazee Paint.
11. General Paint.
12. Kwal Paint.
13. M.A.B. Paints.
14. McCormick Paints.
15. Miller Paint.
16. Parker Paint Mfg. Co. Inc.
17. PPG Industries.
18. Pratt & Lambert.
19. Rodda Paint Co.
20. Rohm and Haas Company; a subsidiary of The Dow Chemical Company.
21. Scott Paint Company.
22. Sherwin-Williams Company (The).

2.2 PAVEMENT-MARKING PAINT

- A. Pavement-Marking Paint: MPI #32, alkyd traffic-marking paint.
 1. Color: white; blue in handicap areas.
- B. Pavement-Marking Paint: MPI #97, latex traffic-marking paint.
 1. Color: white; blue in handicap areas.
- C. Glass Beads: AASHTO M 247, Type 1, made of 100 percent recycled glass.
- D. VOC Content: Pavement markings used on building interior shall have a VOC content of 150 g/L or less.

PART 3 - EXECUTION

3.1 PAVEMENT MARKING

- A. Do not apply pavement-marking paint until layout, colors, and placement have been verified with Architect.
- B. Allow paving to age for a minimum of 30 days before starting pavement marking.
- C. Sweep and clean surface to eliminate loose material and dust.
- D. Apply paint with mechanical equipment to produce pavement markings, of dimensions indicated, with uniform, straight edges. Apply at manufacturer's recommended rates to provide a minimum wet film thickness of 0.4 mm (15 mils).
 - 1. Apply graphic symbols and lettering with paint-resistant, die-cut stencils. Apply paint so that it cannot run beneath the stencil.
 - 2. Broadcast glass beads uniformly into wet markings at a rate of 0.72 kg/L (6 lb/gal.).

END OF SECTION 321723

SECTION 323119 - DECORATIVE METAL FENCES AND GATES

PART 1 - GENERAL

1.1 SUMMARY

A. Section Includes:

1. Aluminum security fence assembly
2. Aluminum decorative privacy fences.
3. Swing gates.
4. Horizontal-slide gates.
5. Gate operators.

B. Related Requirements:

1. Section 033000 "Cast-in-Place Concrete" for concrete bases for gate operators, drives, and controls and post concrete fill.
2. Section 281500 "Integrated Access Control Hardware Devices" for access control devices installed at gates and provided as part of a security system.
3. Division 26 Sections for electrical service and connections for system disconnect switches and powered devices including, but not limited to, motor operators, controls, and limit switches.

1.2 REFERENCES

A. The Aluminum Association, Inc.

1. AA DAF-45 2003 (2009) Designation System for Aluminum Finishes

B. ASTM International:

1. ASTM B209-14, Standard Specification for Aluminum Sheet and Plate
2. ASTM B429, Standard Specification for Aluminum Extruded Structural Pipe & Tube

1.3 ACTION SUBMITTALS

A. Product Data:

1. For each type of product.

B. Shop Drawings: For fencing and gates.

1. Include plans, elevations, sections, gate locations, post spacing, and mounting attachment details, and grounding details.

2. Gate Operator: Show locations and details for installing operator components, switches, and controls. Indicate motor size, electrical characteristics, drive arrangement, exit ground loop, mounting, and grounding provisions.
3. Wiring Diagrams: Include diagrams for power, signal, and control wiring.

C. Samples: For each fence material and for each color specified.

1. Provide Samples **12 inches** square for sheet or plate materials.

1.4 INFORMATIONAL SUBMITTALS

A. Field quality-control reports.

1.5 CLOSEOUT SUBMITTALS

A. Maintenance Data: For gate operators to include in maintenance manuals.

1.6 QUALITY ASSURANCE

- A. Installer Qualifications: Fabricator of products.
- B. Comply with Standards and Codes listed in Article 1.2 REFERENCES.
- C. Welding Qualifications: Qualify procedures and personnel according to the following: AWS D1.2/D1.2M for aluminum.

PART 2 - PRODUCTS

2.1 PERFORMANCE REQUIREMENTS

- A. Wind Loading:
 1. Fence Height: .
 2. Wind Exposure Category: C.
 3. Design Wind Speed: See Structural Drawings.

2.2 DECORATIVE ALUMINUM FENCES

- A. Aluminum Security Fence Assembly:
- B. Basis-of-Design Product: subject to compliance with requirements, provide Ameristar Perimeter Security; Echelon II or Approved Equivalent by one of the following:
 1. Alumi-Guard; Barrette Outdoor Living, Inc.
 2. Ameristar Perimeter Security; ASSA ABLOY

3. Carfaro, Inc.
 4. Delair Group, L.L.C.
 5. East & West Alum Craft Ltd.
 6. Elegant Aluminum Products, Inc.
 7. Elite Fence Products, Inc.
 8. Fortress Building Products
 9. Ideal Aluminum Products
 10. Iron Eagle Industries, Inc.
 11. Japra Group International
 12. Jerith Manufacturing LLC.; ASSA ABLOY
 13. Knotwood US LLC
 14. Master-Halco, Inc.
 15. Merchants Metals, LLC
 16. Royal Aluminum and Steel, Inc.
 17. Specrail
 18. Superior Aluminum Products, Inc
 19. Tek-Rail Inc.
 20. Ultra Aluminum Manufacturing Inc.
 21. Virginia Railing and Gates, LLC
- C. Aluminum material for fence framework shall conform to the requirements of ASTM B221. The aluminum extrusions for posts and rails shall be Alloy and Temper Designation 6005-T5. The aluminum extrusions for pickets shall be Alloy and Temper Designations 6063-T52. The industrial ornamental aluminum fence system shall conform to Ameristar Echelon II Classic manufactured by Ameristar Perimeter Security USA Inc.
- D. The manufactured frameowrk shall be subjected to the Ameristar thermal stratification coating process including as a minimum, a six-stage pretreatment/wash, and an electrostatic spray application of a polyester finish. The topcoat shall be a "no-mar" TGIC polyester powder coat finish with a minimum thickness of 2 mils. The color to be selected by Architect. The stratification-coated framework shall be capace of meeting the performance requirements for each quality characteristic shown in Table 2.
- E. Material for fence pickets shall be 1" square x 0.062" thick extruded tubing. The cross-sectional shape of the rails shall conform to the manufacturer's ForeRunner design with outside cross-section dimensions of 1.75" square. The top wall and internal web of hte rail shall be 0.070" thick; the sidewalls shall be 0.070" thick for superior veretical load strength. Picket holes in the ForeRunner rail shall be spaced 4.715" o.c. Picket retaining rods shall be 0.125" diameter galvanized steel. Fence posts and gate posts shall meet the minimum size requirements of Table 1. High quality PVC grommets shall be supplied to seal all picket-to-rail-intersections.
- F. Bracket to rail attachments shall be made using specially designed one-way tamperproof security nuts with carriage bolt. Bracket to post connections shall be made using self-drilling hex-head screws.
- G. Aluminum castings shall be used for all rings, post caps, finials, and miscellaneous adornments.

- H. Pickets: Extruded-aluminum tubes, **3/4 inch** square, with **0.050-inch** wall thickness.
 - 1. Picket Placement: Extend pickets beyond top rail as indicated on Drawings and press flat and trim to produce spear point shape Extend pickets beyond top rail as indicated on Drawings and terminate with cast-aluminum spear point finial.
 - 2. Picket Spacing: **6 inches** clear, maximum.
- I. Fasteners:
 - 1. Manufacturer's standard corrosion-resistant, color-coated fasteners matching fence components.

2.3 DECORATIVE PRIVACY FENCE

- A. Basis-of-Design Product: subject to compliance with requirements, provide Stellarcraft Nebula Perforated Aluminum Fencing or equivalent product.
 - 1. An equivalent fence assembly may be shop fabricated by a metal vendor.
- B. Fabrication:
 - 1. Perforated Fence Panels: Aluminum plate - 5052, 0.188-in. thick. Square Perforation Pattern - Open Area 25% or less open area. Provide sample for approval.
 - 2. Maximum Panel Material Thickness not to exceed 0.314" (8mm). Maximum Panel Material length not to exceed 60 inches. Fence post & panel height as indicated in drawings.
 - 3. Aluminum Tube Supports: ASTM B221, 6061-T6 alloy, extruded tubing, and 0.120-in. wall thickness
 - 4. Aluminum Tube Support Caps: ASTM B209, 5052 alloy; aluminum plate, 0.190-in. thick
 - 5. Exposed Fasteners: Flush countersunk screws or bolts, consistent with design of fence. Stainless steel or other corrosion resistant material.
 - 6. Finish: High Performance Organic Finish: Twocoat fluoropolymer finish complying with AAMA 2605 and containing not less than 70 percent PVDF resin by weight in color coat. Prepare, pretreat, and apply coating to exposed metal surfaces to comply with coating and resin manufacturers' written instructions - Kynar or similar. a. Color and Gloss: As selected by Architect from manufacturer's full range.
 - 7. Performance Criteria: Allow for thermal movements from ambient and surface temperature changes acting on exterior metal fabrications by preventing buckling, opening of joints, overstressing of components, failure of connections, and other detrimental effects. Prevent galvanic action and other forms of corrosion by insulating metals and other materials from direct contact with incompatible materials.

2.4 GATE OPERATORS

- A. Gate Operator Components: Provide factory-assembled automatic operating system

designed for gate size, type, weight, and operation frequency. Provide operation control system with characteristics suitable for Project conditions, with remote-control stations, safety devices, and weatherproof enclosures; coordinate electrical requirements with building electrical system.

1. Design operator so that motor may be removed without disturbing limit-switch adjustment and without affecting auxiliary emergency operator.
 2. Provide UL 325-listed operators for swing gates BHMA A156.19-listed operators for pedestrian gates ASTM F2200-listed automated vehicular gates.
- B. Comply with NFPA 70.
- C. Gate Operator to communicate with Access Control system across project. Provide hardware, controls, electrical, sensors, data infrastructure, and any other components required.

2.5 MISCELLANEOUS MATERIALS

- A. Welding Rods and Bare Electrodes: Select in accordance with AWS specifications for metal alloy welded.
- B. Nonshrink Grout: Factory-packaged, nonstaining, noncorrosive, nongaseous grout complying with ASTM C1107/C1107M and specifically recommended in writing by manufacturer for exterior applications.

2.6 GROUNDING MATERIALS

- A. Grounding Conductors: Size as indicated on Drawings. Bare, solid wire for No. 6 AWG and smaller; stranded wire for No. 4 AWG and larger.
1. Material above Finished Grade: Copper Aluminum.
 2. Material on or below Finished Grade: Copper.
 3. Bonding Jumpers: Braided copper tape, **1-5/8 inch** wide and **1/16 inch** thick, woven of No. 30 AWG bare copper wire, terminated with copper ferrules.
- B. Grounding Connectors and Grounding Rods: Comply with UL 467.
1. Connectors for Below-Grade Use: Exothermic-welded type.
 2. Grounding Rods: Copper-clad steel.
 - a. Size: **5/8 by 96 inches**.

PART 3 - EXECUTION

3.1 EXAMINATION

- A. Examine areas and conditions, with Installer present, for compliance with requirements

for site clearing, earthwork, pavement work, construction layout, and other conditions affecting performance of the Work.

- B. Do not begin installation before final grading is completed unless otherwise permitted by Architect.

3.2 PREPARATION

- A. Stake locations of fence lines, gates, and terminal posts. Do not exceed intervals of **50 feet**. or line of sight between stakes. Indicate locations of utilities, lawn sprinkler system, underground structures, benchmarks, and property monuments.
 - 1. Verify locations of walls and other construction contiguous with metal fencing fabrications by field measurements prior to fabrication.
- B. Coordinate post setting and directions for installation of anchorages, such as sleeves, inserts, anchor bolts or other miscellaneous items that are to be embedded in concrete construction. Coordinate delivery of such items to project site in an appropriate timeline.

3.3 INSTALLATION OF DECORATIVE FENCES

- A. Install fences in accordance with manufacturer's written instructions.
- B. For Panelized fence, tops of panels shall be level within 1/4" variation in 12 feet unless explicitly stated and approved in shop drawings.
- C. Fit panels together to form tight hairline joints, free from distortion or other defects. Perform cutting and fitting as required for installing fence elements and panels. Do not weld, cut or abrade surfaces of fence components that have been coated or finished after fabrication and that are intended for field connection by mechanical or other means without further cutting or fitting.
- D. Install fences by setting posts as indicated on Drawings and fastening rails and infill panels to posts. Plumb posts in all directions.
- E. Post Excavation: Drill or hand-excavate holes for posts in firm, undisturbed soil. Excavate holes to a diameter of not less than 4 times post size and a depth of not less than **24 inches** plus **3 inches** for each **foot** or fraction of a **foot** that fence height exceeds **4 ft.**

3.4 INSTALLATION OF GATES

- A. Install gates in accordance with manufacturer's written instructions, level, plumb, and secure for full opening without interference. Attach hardware using tamper-resistant or concealed means. Install ground-set items in concrete for anchorage. Adjust hardware for smooth operation and lubricate where necessary.

3.5 INSTALLATION OF GATE OPERATORS

- A. General: Install gate operators in accordance with manufacturer's written instructions, aligned and true to fence line and grade.
- B. Excavation: Hand-excavate holes for support posts pedestals concrete bases in firm, undisturbed soil to dimensions and depths and at locations as required by gate operator component manufacturer's written instructions and as indicated on Drawings.
- C. Concrete Bases: Cast-in-place or precast concrete, , dimensioned and reinforced in accordance with gate operator component manufacturer's written instructions and as indicated on Drawings.
- D. Vehicle-Sensing System: bury and seal wire loop in accordance with manufacturer's written instructions. Connect to equipment operated by detector.
- E. Comply with NFPA 70 and manufacturer's written instructions for grounding of electric-powered motors, controls, and other devices.

3.6 ADJUSTING

- A. Gates: Adjust gates to operate smoothly, easily, and quietly, free of binding, warp, excessive deflection, distortion, nonalignment, misplacement, disruption, or malfunction, throughout entire operational range. Confirm that latches and locks engage accurately and securely without forcing or binding.
- B. Automatic Gate Operators: Energize circuits to electrical equipment and devices. Adjust operators, controls, safety devices, alarms, and limit switches.
 - 1. Operational Test: After electrical circuitry has been energized, start units to confirm proper motor rotation and unit operation.
 - 2. Test and adjust controls, alarms, and safeties. Replace damaged and malfunctioning controls and equipment.

3.7 DEMONSTRATION

- A. Train Owner's personnel to adjust, operate, and maintain gates.

END OF SECTION 323119

SECTION 323119.53 - DECORATIVE METAL SECURITY FENCES AND GATES

PART 1 - GENERAL

1.1 SUMMARY

A. Section Includes:

1. Swing gates.
2. Horizontal-slide gates.

B. Related Requirements:

1. Section 281500 "Integrated Access Control Hardware Devices" for access control devices installed at gates and provided as part of a security system.
2. Division 26 Sections for electrical service and connections for system disconnect switches and powered devices including, but not limited to, motor operators, controls, and limit switches.

1.2 ACTION SUBMITTALS

A. Product Data:

1. For each type of product.

B. Shop Drawings: For fencing and gates.

1. Include plans, elevations, sections, gates and locations, post spacing, and mounting attachment details, and grounding details.
2. Gate Operator: Show locations and details for installing operator components, switches, exit loops and controls. Indicate motor size, electrical characteristics, drive arrangement, mounting, and grounding provisions.
3. Wiring Diagrams: Include diagrams for power, signal, and control wiring.

C. Samples: For each fence material and for each color specified.

1. Provide Samples **12 inches** square for plate materials..

1.3 INFORMATIONAL SUBMITTALS

A. Field quality-control reports.

1.4 CLOSEOUT SUBMITTALS

A. Operation and Maintenance Data: For gate operators to include in emergency,

operation, and maintenance manuals.

1.5 QUALITY ASSURANCE

- A. Installer Qualifications: Company with demonstrated successful experience installing similar projects , including automation, and products in accordance with ASTM F567 and have at least five years' experience.
- B. Emergency Access Requirements: In accordance with requirements of authorities having jurisdiction for gates with automatic gate operators serving as a required means of access.

1.6 FIELD CONDITIONS

- A. Field Measurements: Verify layout information for fences and gates shown on Drawings in relation to property survey and existing structures. Verify dimensions by field measurements.

1.7 WARRANTY

- A. Special Warranty: Manufacturer agrees to repair or replace components of fences, and gates, operators, and controls that fail in materials or workmanship within specified warranty period.
 - 1. Failures include, but are not limited to, the following:
 - a. Failure to comply with performance requirements.
 - b. Deterioration of metals, metal finishes, and other materials beyond normal weathering.
- B. Warranty Period: Limited Lifetime for Echelon II Classic fence and TransPort Traverse II security gate.

PART 2 - PRODUCTS

2.1 PERFORMANCE REQUIREMENTS

- A. Wind Loading:
 - 1. Fence Height: .
 - 2. Wind Exposure Category: C.
 - 3. Design Wind Speed: 107 mph.
- B. Lightning-Protection System: Maximum grounding-resistance value of 25 ohms under normal dry conditions.

- C. Vehicle Crash Testing: Comply with requirements of ASTM F2656.
- D. Accessibility: Pedestrian gates to comply with the United States Access Board's ADA-ABA Accessibility Guidelines.

2.2 SWING GATES

- A. Gate Configuration: Single leaf As indicated for pedestrian systems.
- B. Manufacturer: Ameristar Premium Security; Echelon II Classic.
- C. Gate Frame Height: As indicated.
- D. Gate Opening Width: As indicated.
- E. Gate Type: Pedestrian gate assembly to comply with Provide automated pedestrian gates in accordance with ANSI 156.19 or 156.10.
 - 1. Automated vehicular gates are to comply with ASTM F2200, Class II.
- F. The industrial ornamental aluminum fence system shall conform to Ameristar Echelon II Classic manufactured by Ameristar Perimeter Security USA Inc.
- G. Aluminum material for fence framework shall conform to the requirements of ASTM B221. The aluminum extrusions for posts and rails shall be Alloy and Temper Designation 6005-T5. The aluminum extrusions for pickets shall be Alloy and Temper Designations 6063-T52.
- H. The manufactured frameowrk shall be subjected to the Ameristar thermal stratification coating process including as a minimum, a six-stage pretreatment/wash, and an electrostatic spray application of a polyester finish. The topcoat shall be a "no-mar" TGIC polyester powder coat finish with a minimum thickness of 2 mils. The color to be selected by Architect. The stratification-coated framework shall be capace of meeting the performance requirements for each quality characteristic shown in Table 2.
- I. Material for fence pickets shall be 1" square x 0.062" thick extruded tubing. The cross-sectional shape of the rails shall conform to the manufacturer's ForeRunner design with outside cross-section dimensions of 1.75" square. The top wall and internal web of hte rail shall be 0.070" thick; the sidewalls shall be 0.070" thick for superior veretical load strength. Picket holes in the ForeRunner rail shall be spaced 4.715" o.c. Picket retaining rods shall be 0.125" diameter galvanized steel. Fence posts and gate posts shall meet the minimum size requirements of Table 1. High quality PVC grommets shall be supplied to seal all picket-to-rail-intersections.
- J. Bracket to rail attachments shall be made using specially designed one-way tamperproof security nuts with carriage bolt. Bracket to post connections shall be made using self-drilling hex-head screws.
- K. Aluminum castings shall be used for all rings, post caps, finials, and miscellaneous adornments.

- L. Additional Rails: Provide as indicated, complying with requirements for fence rails.
- M. Hardware: Latches permitting operation from both sides of gate, hinges, and keepers for each gate leaf more than **5 feet** wide. Provide center gate stops and cane bolts for pairs of gates.
- N. Spring Hinges: BHMA A156.17, Grade 1, suitable for exterior use.
 - 1. Function: 320 - Gate spring pivot hinge. Adjustable tension.
 - 2. Material: Malleable iron; galvanized.
- O. Rim Locks: BHMA A156.5, Grade 1, suitable for exterior use.
- P. Electric Strikes: BHMA A156.31, Grade 1, of configuration required for use with lock specified, fail-secure, and suitable for exterior use.
 - 1. Mounting Plate: Configuration necessary for mounting electric strikes. Fabricate from **1/8-inch-** thick, steel plate; galvanized.
 - 2. Mounting: Mortise into post.
- Q. Exit Hardware: BHMA A156.3, Grade 1, Type 1 (rim exit device), with push pad actuating bar, suitable for exterior use.
 - 1. Function: Confirm with Architect.
 - 2. Mounting Channel: Bent-plate channel formed from **1/8-inch-** thick, steel plate. Channel spans gate frame. Exit device is mounted on channel web, recessed between flanges, with flanges extending **1/8 inch** beyond push pad surface.
- R. Galvanizing: For items other than hardware that are indicated to be galvanized, hot-dip galvanize to comply with ASTM A123/A123M. For hardware items, hot-dip galvanize to comply with ASTM A153/A153M.
- S. Metallic-Coated-Steel Finish: Galvanized finish.
- T. Steel Finish: Shop painted.

2.3 HORIZONTAL-SLIDE GATES

- A. Gate Configuration: Single leaf for vehicle assembly.
 - 1. Type:
 - a. Overhead slide.
 - b. Cantilever slide, with external roller assemblies.
 - c. Groundtrack slide.
- B. Manufacturer: Assa Abloy; Transport Traverse Classic
- C. Gate Frame Height: As indicated.

- D. Gate Opening Width: Field Verify.
- E. Automated vehicular gates are to comply with ASTM F2200, Class II.

PART 3 - EXECUTION

3.1 INSTALLATION OF DECORATIVE METAL SECURITY FENCES

- A. Install gate system and fences in accordance with manufacturer's written instructions.
- B. Cantilever support posts shall be set in concrete footers having a minimum depth of 48" (Note: Coordinate depth with project conditions).
- C. Gate to be installed per manufacturer gate installation instructions. For Gates that will be automated, the contractor shall be responsible to ensure the gate, and installation, meet ASTM F2200 and UL325 Standards.
- D. Gate posts shall be spaced according to the manufacturers' drawings, dependent on clear opening. The manufacturers' gate drawings shall identify the necessary gate hardware of the gate and shall be installed per manufacturer's recommendations.

3.2 INSTALLATION OF DECORATIVE METAL SECURITY GATES

- A. Install gates in accordance with manufacturer's written instructions, level, plumb, and secure for full opening without interference. Attach hardware using tamper-resistant or concealed means. Install ground-set items in concrete for anchorage. Adjust hardware for smooth operation and lubricate where necessary.
- B. Fence post shall be spaced according to Table 3, plus or minus 1/2". For installations that must be raked to follow sloping grades, the post spacing dimension must be measured along the grade. Fence panels shall be attached to posts with brackets supplied by the manufacturer. Posts shall be set in concrete footers having a minimum depth of 36". Posts setting by other methods such as plated posts or grouted core-drilled footers are permissible only if shown by engineering analysis to be sufficient in strength or intended application.

3.3 FIELD QUALITY CONTROL

- A. Testing Agency: Engage a qualified testing agency to perform tests and inspections.
 - 1. Grounding-Resistance Tests: Subject completed grounding system to a megger test at each grounding location. Measure grounding resistance not less than two full days after last trace of precipitation, without soil having been moistened by any means other than natural drainage or seepage and without chemical treatment or other artificial means of reducing natural grounding resistance. Perform tests by two-point method in accordance with IEEE 81.
 - 2. Excessive Grounding Resistance: If resistance to grounding exceeds specified

value, notify Architect promptly. Include recommendations for reducing grounding resistance and a proposal to accomplish recommended work.

3. Report: Prepare test reports of grounding resistance at each test location certified by a testing agency. Include observations of weather and other phenomena that may affect test results.

3.4 DEMONSTRATION

- A. Train Owner's personnel to adjust, operate, and maintain gates.

END OF SECTION 323119.53

SECTION 323300 - SITE FURNISHINGS

PART 1 - GENERAL

1.1 SUMMARY

A. Section Includes:

1. Seating.
2. Bicycle racks.
3. Trash receptacles.
4. Bollards.

B. Related Requirements:

1. Section 033000 "Cast-in-Place Concrete" for installing pipe sleeves cast in concrete footings.
2. Section 312000 "Earth Moving" for excavation for installing concrete footings.

1.2 ACTION SUBMITTALS

A. Product Data: For each type of product.

B. Sustainable Design Submittals:

1. Chain-of-Custody Certificates: For certified wood products. Include statement of costs.

C. Samples: For each exposed product and for each color and texture specified.

D. Product Schedule: For site furnishings..

1.3 INFORMATIONAL SUBMITTALS

A. Material Certificates: For site furnishings manufactured with preservative-treated wood.

1. Indicate type of preservative used and net amount of preservative retained. For products receiving a waterborne treatment, include statement that moisture content of treated materials was reduced to levels specified before shipment to Project site.

1.4 CLOSEOUT SUBMITTALS

A. Maintenance Data: For site furnishings to include in maintenance manuals.

PART 2 - PRODUCTS

2.1 SEATING

A. Basis-of-Design Product

1. Subject to compliance with requirements, provide DuMor, Inc. Bench 270-60I: 6' Long Steel w/ Ipe Slats or comparable product.

B. Frame: Cast aluminum Steel.

C. Seat and Back:

1. Material:
 - a. Wood: Cedar Ipe; formed into evenly spaced parallel slats planks.
 - b. Recycled Plastic Planks: Evenly spaced, parallel.
2. Arms: Two, one at each end.
 - a. Arm Material: Match Per Manufacturer.
3. Seating Configuration: Multiple units Per Drawings.

2.2 BICYCLE RACKS

A. Manufacturers: Subject to compliance with requirements, available manufacturers offering products that may be incorporated into the Work include, but are not limited to, the following:

1. A A A Ribbon Rack Co., Inc.; a division of Brandir
2. American Bicycle Security Company
3. BCI Burke Company, LLC
4. Bison, Inc.
5. brp by bison
6. Canterbury Design
7. Columbia Cascade Company
8. Cora Bike Rack
9. CycleSafe, Inc.
10. DuMor Inc.
11. GameTime; a PlayCore Company
12. Ground Control Systems
13. Henderson Recreation Equipment Ltd
14. Huntco Supply, LLC
15. Kay Park Recreation
16. Keystone Ridge Designs, Inc
17. Kidstuff Playsystems, Inc.
18. L.A. Steelcraft, a brand of Americana Outdoor
19. Landscape Forms

20. Landscape Structures Inc.
21. Madrax; Graber Manufacturing, Inc.
22. Maglin Site Furniture Inc.
23. Miracle Recreation Equipment Company
24. Neenah Foundry Company
25. Playworld Systems, Inc.
26. RPI
27. Saris Infrastructure
28. SportsPlay Equipment, Inc
29. Tournesol Siteworks LLC
30. Urban Accessories, Inc
31. Victor Stanley, Inc
32. Wausau Tile, Inc.

B. Bicycle Rack Construction:

1. Frame: Steel.

C. Steel Finish: Color coated.

1. Color: As selected by Architect from manufacturer's full range.

2.3 TRASH RECEPTACLES

- A. Basis of Design Product: Subject to compliance with requirements, provide DuMor Inc. Receptacle 272-32-SO 32 gallon Side Deposit receptacle or Approved Equivalent.

2.4 BOLLARDS

- A. Basis-of-Design Product: Subject to compliance with requirements, provide Barrier Defense Systems; 30 Degree 8" Slope Top Bollard Cover or Approved Equivalent by one of the following:

1. 1-800-Bollards
2. brp by bison
3. CAME Americas Automation LLC
4. Canterbury Design
5. Columbia Cascade Company
6. Dero; a PlayCore company
7. DuMor Inc.
8. Huntco Supply, LLC
9. L.A. Steelcraft, a brand of Americana Outdoor
10. Maglin Site Furniture Inc.
11. Neenah Foundry Company
12. Petersen Manufacturing Co. Inc.
13. Reliance Foundry Co. Ltd
14. Thomas Steele; Graber Manufacturing, Inc.
15. Tournesol Siteworks LLC
16. Urban Accessories, Inc

17. Victor Stanley, Inc

2.5 MATERIALS

- A. Aluminum: Alloy and temper recommended by aluminum producer and finisher for type of use and finish indicated; free of surface blemishes and complying with the following:
1. Rolled or Cold-Finished Bars, Rods, and Wire: **ASTM B211**.
 2. Extruded Bars, Rods, Wire, Profiles, and Tubes: **ASTM B221**.
 3. Structural Pipe and Tube: ASTM B429/B429M.
 4. Sheet and Plate: **ASTM B209**.
 5. Castings: ASTM B26/B26M.
- B. Steel and Iron: Free of surface blemishes and complying with the following:
1. Plates, Shapes, and Bars: ASTM A36/A36M.
 2. Steel Pipe: Standard-weight steel pipe complying with ASTM A53/A53M, or electric-resistance-welded pipe complying with ASTM A135/A135M.
 3. Tubing: Cold-formed steel tubing complying with ASTM A500/A500M.
 4. Mechanical Tubing: Cold-rolled, electric-resistance-welded carbon or alloy steel tubing complying with ASTM A513/A513M, or steel tubing fabricated from steel complying with ASTM A1011/A1011M and complying with dimensional tolerances in ASTM A500/A500M; zinc coated internally and externally.
 5. Sheet: Commercial steel sheet complying with ASTM A1011/A1011M.
 6. Expanded Metal: Carbon-steel sheets, deburred after expansion, and complying with ASTM F1267.
 7. Malleable-Iron Castings: ASTM A47/A47M, grade as recommended by fabricator for type of use intended.
 8. Gray-Iron Castings: ASTM A48/A48M, Class 200.
- C. Stainless Steel: Free of surface blemishes and complying with the following:
1. Sheet, Strip, Plate, and Flat Bars: ASTM A240/A240M or ASTM A666.
 2. Pipe: Schedule 40 steel pipe complying with ASTM A312/A312M.
 3. Tubing: ASTM A554.
- D. Wood: Surfaced smooth on four sides with eased edges; kiln dried, free of knots, solid stock of species indicated.
1. Wood Species: Manufacturer's standard.
- E. Fiberglass: Multiple laminations of glass-fiber-reinforced polyester resin with UV-light stable, colorfast, nonfading, weather- and stain-resistant, colored polyester gel coat, and with manufacturer's standard finish.
- F. Plastic: Color impregnated, color and UV-light stabilized, and mold resistant.
1. Polyethylene: Fabricated from virgin plastic HDPE resin.
- G. Anchors, Fasteners, Fittings, and Hardware: Manufacturer's standard, corrosion-

resistant-coated or noncorrodible materials; commercial quality.

- H. Nonshrink, Nonmetallic Grout: Premixed, factory-packaged, nonstaining, noncorrosive, nongaseous grout complying with ASTM C1107/C1107M; recommended in writing by manufacturer, for exterior applications.
- I. Erosion-Resistant Anchoring Cement: Factory-packaged, nonshrink, nonstaining, hydraulic-controlled expansion cement formulation for mixing with potable water at Project site to create pourable anchoring, patching, and grouting compound; resistant to erosion from water exposure without needing protection by a sealer or waterproof coating; recommended in writing by manufacturer, for exterior applications.
- J. Galvanizing: Where indicated for steel and iron components, provide the following protective zinc coating applied to components after fabrication:
 - 1. Zinc-Coated Tubing: External, zinc with organic overcoat, consisting of a minimum of **0.9 oz./sq. ft.** of zinc after welding, a chromate conversion coating, and a clear, polymer film. Internal, same as external or consisting of 81 percent zinc pigmented coating, not less than **0.3 mil** thick.
 - 2. Hot-Dip Galvanizing: According to ASTM A123/A123M, ASTM A153/A153M, or ASTM A924/A924M.

2.6 WOOD-PRESERVATIVE-TREATED MATERIALS

- A. Preservative Treatment: Pressure-treat wood according to AWWA U1, Use Category UC3b, and the following:
 - 1. Use preservative chemicals acceptable to authorities having jurisdiction and containing no arsenic or chromium. Use chemical formulations that do not bleed through or otherwise adversely affect finishes. Do not use colorants to distinguish treated materials from untreated materials.
 - 2. Kiln-dry lumber and plywood after treatment to a maximum moisture content, respectively, of 19 and 15 percent. Do not use materials that are warped or do not comply with requirements for untreated materials.

2.7 FABRICATION

- A. Metal Components: Form to required shapes and sizes with true, consistent curves, lines, and angles. Separate metals from dissimilar materials to prevent electrolytic action.
- B. Welded Connections: Weld connections continuously. Weld solid members with full-length, full-penetration welds and hollow members with full-circumference welds. At exposed connections, finish surfaces smooth and blended, so no roughness or unevenness shows after finishing and welded surface matches contours of adjoining surfaces.
- C. Pipes and Tubes: Form simple and compound curves by bending members in jigs to produce uniform curvature for each repetitive configuration required; maintain

cylindrical cross section of member throughout entire bend without buckling, twisting, cracking, or otherwise deforming exposed surfaces of handrail and railing components.

- D. Preservative-Treated Wood Components: Complete fabrication of treated items before treatment if possible. If cut after treatment, apply field treatment complying with AWPA M4 to cut surfaces.
- E. Exposed Surfaces: Polished, sanded, or otherwise finished; all surfaces smooth, free of burrs, barbs, splinters, and sharpness; all edges and ends rolled, rounded, or capped.
- F. Factory Assembly: Factory assemble components to greatest extent possible to minimize field assembly. Clearly mark units for assembly in the field.

2.8 GENERAL FINISH REQUIREMENTS

- A. Appearance of Finished Work: Noticeable variations in same piece are unacceptable. Variations in appearance of adjoining components are acceptable if they are within the range of approved Samples and are assembled or installed to minimize contrast.

2.9 ALUMINUM FINISHES

- A. Powder-Coat Finish: Manufacturer's standard polyester powder-coat finish complying with finish manufacturer's written instructions for surface preparation, including pretreatment, application, baking, and minimum dry film thickness.

2.10 STEEL AND GALVANIZED-STEEL FINISHES

- A. Powder-Coat Finish: Manufacturer's standard polyester, powder-coat finish complying with finish manufacturer's written instructions for surface preparation, including pretreatment, application, baking, and minimum dry film thickness.
- B. PVC Finish: Manufacturer's standard, UV-light stabilized, mold-resistant, slip-resistant, matte-textured, dipped or sprayed-on, PVC-plastisol finish, with flame retardant added; complying with coating manufacturer's written instructions for pretreatment, application, and minimum dry film thickness.

2.11 IRON FINISHES

- A. Powder-Coat Finish: Manufacturer's standard polyester powder-coat finish complying with finish manufacturer's written instructions for surface preparation, including pretreatment, application, baking, and minimum dry film thickness.

2.12 STAINLESS STEEL FINISHES

- A. Surface Preparation: Remove tool and die marks and stretch lines, or blend into finish.

- B. Polished Finishes: Grind and polish surfaces to produce uniform finish, free of cross scratches.
 - 1. Run directional finishes with long dimension of each piece.
 - 2. Directional Satin Finish: ASTM A480/A480M, No 4.
 - 3. Dull Satin Finish: ASTM A480/A480M, No. 6.

PART 3 - EXECUTION

3.1 INSTALLATION

- A. Comply with manufacturer's written installation instructions unless more stringent requirements are indicated. Complete field assembly of site furnishings where required.
- B. Unless otherwise indicated, install site furnishings after landscaping and paving have been completed.
- C. Install site furnishings level, plumb, true, and securely anchored at locations indicated on Drawings.
- D. Post Setting: Set cast-in support posts in concrete footing with smooth top, shaped to shed water. Protect portion of posts above footing from concrete splatter. Verify that posts are set plumb or at correct angle and are aligned and at correct height and spacing. Hold posts in position during placement and finishing operations until concrete is sufficiently cured.
- E. Posts Set into Voids in Concrete: Form or core-drill holes for installing posts in concrete to depth recommended in writing by manufacturer of site furnishings and **3/4 inch** larger than OD of post. Clean holes of loose material, insert posts, and fill annular space between post and concrete with nonshrink, nonmetallic grout or, mixed and placed to comply with anchoring material manufacturer's written instructions, with top smoothed and shaped to shed water.
- F. Pipe Sleeves: Use steel pipe sleeves preset and anchored into concrete for installing posts. After posts have been inserted into sleeves, fill annular space between post and sleeve with nonshrink, nonmetallic grout or, mixed and placed to comply with anchoring material manufacturer's written instructions, with top smoothed and shaped to shed water.

END OF SECTION 323300

SECTION 329200 – TURF AND GRASSES

PART 1 - GENERAL

1.1 RELATED DOCUMENTS

- A. Drawings and general provisions of the Contract, including General and Supplementary Conditions and Division 01 Specification Sections, apply to this Section.

1.2 SUMMARY

- A. Section Includes:
 - 1. Seeding.
 - 2. Lawn renovation.
- B. Related Sections:
 - 1. Division 31 Section "Site Clearing" for topsoil stripping and stockpiling.
 - 2. Division 31 Section "Earth Moving" for excavation, filling and backfilling, and rough grading.

1.3 DEFINITIONS

- A. Finish Grade: Elevation of finished surface of planting soil.
- B. Manufactured Soil: Soil produced off-site by homogeneously blending mineral soils or sand with stabilized organic soil amendments to produce topsoil or planting soil.
- C. Planting Soil: Native or imported topsoil, manufactured topsoil, or surface soil modified to become topsoil; mixed with soil amendments.
- D. Subgrade: Surface or elevation of subsoil remaining after completing excavation, or top surface of a fill or backfill immediately beneath planting soil.
- E. Subsoil: All soil beneath the topsoil layer of the soil profile, and typified by the lack of organic matter and soil organisms.

1.4 SUBMITTALS

- A. Product Data: For each type of product indicated.
- B. Certification of Grass Seed: From seed vendor for each grass-seed monostand or mixture stating the botanical and common name and percentage by weight of each

species and variety, and percentage of purity, germination, and weed seed. Include the year of production and date of packaging.

- C. Material Test Reports: For existing surface soil and imported topsoil.

1.5 QUALITY ASSURANCE

- A. Installer Qualifications: A qualified landscape installer whose work has resulted in successful lawn and meadow establishment.
 - 1. Installer's Field Supervision: Require Installer to maintain an experienced full-time supervisor on Project site when planting is in progress.
- B. Soil-Testing Laboratory Qualifications: An independent laboratory, recognized by the State Department of Agriculture, with the experience and capability to conduct the testing indicated and that specializes in types of tests to be performed.
- C. Topsoil Analysis: Furnish soil analysis by a qualified soil-testing laboratory stating percentages of organic matter; gradation of sand, silt, and clay content; cation exchange capacity; sodium absorption ratio; deleterious material; pH; and mineral and plant-nutrient content of topsoil.
 - 1. Report suitability of topsoil for lawn growth. State-recommended quantities of nitrogen, phosphorus, and potash nutrients and soil amendments to be added to produce satisfactory topsoil.
- D. Preinstallation Conference: Conduct conference at Project site.

1.6 DELIVERY, STORAGE, AND HANDLING

- A. Seed: Deliver seed in original sealed, labeled, and undamaged containers.

1.7 PROJECT CONDITIONS

- A. Planting Restrictions: Plant during one of the following periods. Coordinate planting periods with initial maintenance periods to provide required maintenance from date of Substantial Completion.
 - 1. Spring Planting: May 15th to June 30th
 - 2. Fall Planting: September 1st to October 31st
 - 3. Meadow: April 15th - June 15th
- B. Weather Limitations: Proceed with planting only when existing and forecasted weather conditions permit.

1.8 MAINTENANCE SERVICE

- A. Initial Lawn Maintenance Service: Provide full maintenance by skilled employees of landscape Installer. Maintain as required in Part 3. Begin maintenance immediately after each area is planted and continue until acceptable lawn is established, but for not less than the following periods:
1. Seeded Lawns: 60 days from date of Substantial Completion.
 - a. When initial maintenance period has not elapsed before end of planting season, or if lawn is not fully established, continue maintenance during next planting season.
- B. Maintain and establish lawn by watering, fertilizing, weeding, mowing, trimming, replanting, and other operations. Roll, regrade, and replant bare or eroded areas and remulch to produce a uniformly smooth lawn.
1. In areas where mulch has been disturbed by wind or maintenance operations, add new mulch. Anchor as required to prevent displacement.
- C. Watering: Provide and maintain temporary piping, hoses, and lawn-watering equipment to convey water from sources and to keep lawn uniformly moist to a depth of 4 inches (100 mm).
1. Schedule watering to prevent wilting, puddling, erosion, and displacement of seed or mulch. Lay out temporary watering system to avoid walking over muddy or newly planted areas.
 2. Water lawn at a minimum rate of 1 inch (25 mm) per week.
- D. Mow lawn as soon as top growth is tall enough to cut. Repeat mowing to maintain specified height without cutting more than 40 percent of grass height. Remove no more than 40 percent of grass-leaf growth in initial or subsequent mowings. Do not delay mowing until grass blades bend over and become matted. Do not mow when grass is wet. Schedule initial and subsequent mowings to maintain the following grass height:
1. Mow grass 1-1/2 to 2 inches (38 to 50 mm) high.
- E. Lawn Postfertilization: Apply fertilizer after initial mowing and when grass is dry.
1. Use fertilizer that will provide actual nitrogen of at least 1 lb/1000 sq. ft. (0.45 kg/92.9 sq. m) to lawn area.

PART 2 - PRODUCTS

2.1 SEED

- A. Grass Seed: Fresh, clean, dry, new-crop seed complying with AOSA's "Journal of Seed Technology; Rules for Testing Seeds" for purity and germination tolerances.

- B. Seed Species: State-certified seed of grass species, as indicated in Seed Mixture Schedule at the end of this section.

2.2 TOPSOIL

- A. Topsoil: ASTM D 5268, pH range of 5.5 to 7, a minimum of 4 percent organic material content; free of stones 1 inch (25 mm) or larger in any dimension and other extraneous materials harmful to plant growth.
 - 1. Topsoil Source: Reuse surface soil stockpiled on-site. Verify suitability of stockpiled surface soil to produce topsoil. Clean surface soil of roots, plants, sod, stones, clay lumps, and other extraneous materials harmful to plant growth.
 - a. Supplement with imported or manufactured topsoil from off-site sources when quantities are insufficient. Obtain topsoil displaced from naturally well-drained construction or mining sites where topsoil occurs at least 4 inches (100 mm) deep; do not obtain from agricultural land, bogs or marshes.

2.3 PLANTING ACCESSORIES

- A. Selective Herbicides: EPA registered and approved, of type recommended by manufacturer for application.

2.4 FERTILIZER

- A. Commercial Fertilizer: Commercial-grade complete fertilizer of neutral character, consisting of fast- and slow-release nitrogen, 50 percent derived from natural organic sources of urea formaldehyde, phosphorous, and potassium in the following composition:
 - 1. Composition: 1 lb/1000 sq. ft. (0.45 kg/92.9 sq. m) of actual nitrogen, 4 percent phosphorous, and 2 percent potassium, by weight.

2.5 MULCHES

- A. Straw Mulch: Provide air-dry, clean, mildew- and seed-free, salt hay or threshed straw of wheat, rye, oats, or barley.
- B. Fiber Mulch: Biodegradable, dyed-wood, cellulose-fiber mulch; nontoxic; free of plant-growth or germination inhibitors; with a maximum moisture content of 15 percent and a pH range of 4.5 to 6.5.
- C. Nonasphaltic Tackifier: Colloidal tackifier recommended by fiber-mulch manufacturer for slurry application; nontoxic and free of plant-growth or germination inhibitors.

2.6 EROSION-CONTROL MATERIALS

- A. Erosion-Control Blankets: Biodegradable wood excelsior, straw, or coconut-fiber mat enclosed in a photodegradable plastic mesh. Include manufacturer's recommended steel wire staples, 6 inches (150 mm) long.

PART 3 - EXECUTION

3.1 EXAMINATION

- A. Examine areas to receive lawns and grass for compliance with requirements and other conditions affecting performance.
- B. Proceed with installation only after unsatisfactory conditions have been corrected.

3.2 PREPARATION

- A. Protect structures, utilities, sidewalks, pavements, and other facilities, trees, shrubs, and plantings from damage caused by planting operations.
 - 1. Protect adjacent and adjoining areas from hydroseeding overspray.
- B. Provide erosion-control measures to prevent erosion or displacement of soils and discharge of soil-bearing water runoff or airborne dust to adjacent properties and walkways.

3.3 LAWN PREPARATION

- A. Limit lawn subgrade preparation to areas to be planted.
- B. Newly Graded Subgrades: Loosen subgrade to a minimum depth of 6 inches (150 mm). Remove stones larger than 1 inch (25 mm) in any dimension and sticks, roots, rubbish, and other extraneous matter and legally dispose of them off Owner's property.
 - 1. Spread planting soil mix to a depth of 6 inches (150 mm) but not less than required to meet finish grades after light rolling and natural settlement. Do not spread if planting soil or subgrade is frozen, muddy, or excessively wet.
- C. Finish Grading: Grade planting areas to a smooth, uniform surface plane with loose, uniformly fine texture. Grade to within plus or minus 1/2 inch (13 mm) of finish elevation. Roll and rake, remove ridges, and fill depressions to meet finish grades. Limit finish grading to areas that can be planted in the immediate future.
- D. Moisten prepared lawn areas before planting if soil is dry. Water thoroughly and allow surface to dry before planting. Do not create muddy soil.

- E. Before planting, restore areas if eroded or otherwise disturbed after finish grading.

3.4 DRILL SEEDING/ HYDROMULCHING LAWNS

- A. Lawn and meadow seed mixes shall be mechanically seeded with a "Brillion" or equivalent seeding machine. Do not broadcast or drop seed. Evenly distribute seed by sowing equal quantities in two directions at right angles to each other.
 - 1. Do not use wet seed or seed that is moldy or otherwise damaged.
 - 2. Sow seed at the rate of 8 lb per 1000 sq. ft. (3.8 kg per 100 sq. m).
- B. Hydromulch within 24 hours after completing seeding operations.
- C. Mix specified fertilizer and fiber mulch in water, using equipment specifically designed for hydroseed application. Continue mixing until uniformly blended into homogeneous slurry suitable for hydraulic application.
- D. Apply slurry uniformly to all seeded areas in a one-step process. Apply mulch at a minimum rate of 1500-lb/acre (15.3-kg/92.9 sq. m) dry weight.

3.5 PREPARATION FOR EROSION-CONTROL MATERIALS

- A. Prepare area as specified in "Lawn Preparation" Article.
- B. For erosion-control blanket, install from top of slope, working downward, and as recommended by material manufacturer for site conditions. Fasten as recommended by material manufacturer.
- C. Moisten prepared area before planting if surface is dry. Water thoroughly and allow surface to dry before planting. Do not create muddy soil.

3.6 LAWN RENOVATION

- A. Renovate existing lawn damaged by Contractor's operations, such as storage of materials or equipment and movement of vehicles.
 - 1. Reestablish lawn where settlement or washouts occur or where minor regrading is required.
- B. Remove sod and vegetation from diseased or unsatisfactory lawn areas; do not bury in soil.
- C. Remove topsoil containing foreign materials resulting from Contractor's operations, including oil drippings, fuel spills, stone, gravel, and other construction materials, and replace with new topsoil.
- D. Mow, dethatch, core aerate, and rake existing lawn.

- E. Remove weeds before seeding. Where weeds are extensive, apply selective herbicides as required. Do not use pre-emergence herbicides.
- F. Remove waste and foreign materials, including weeds, soil cores, grass, vegetation, and turf, and legally dispose of them off Owner's property.
- G. Till stripped, bare, and compacted areas thoroughly to a soil depth of 6 inches (150 mm).
- H. Apply seed and hydromulch as required for new lawns.
- I. Water newly planted areas and keep moist until new lawn is established.

3.7 SATISFACTORY LAWNS

- A. Lawn installations shall meet the following criteria as determined by Architect:
 - 1. Satisfactory Seeded Lawn: At end of maintenance period, a healthy, uniform, close stand of grass has been established, free of weeds and surface irregularities, with coverage exceeding 90 percent over any 10 sq. ft. (0.92 sq. m) and bare spots not exceeding 5 by 5 inches (125 by 125 mm).
- B. Use specified materials to reestablish lawns that do not comply with requirements and continue maintenance until lawns are satisfactory.

3.8 CLEANUP AND PROTECTION

- A. Promptly remove soil and debris, created by lawn work, from paved areas. Clean wheels of vehicles before leaving site to avoid tracking soil onto roads, walks, or other paved areas.
- B. Erect temporary fencing or barricades and warning signs as required to protect newly planted areas from traffic. Maintain fencing and barricades throughout initial maintenance period and remove after lawn is established.
- C. Remove nondegradable erosion-control measures after grass establishment period.

3.9 SEED MIXTURE SCHEDULE

A. GENERAL SEED MIX

<u>Species</u>	<u>Mix</u>	<u>Purity</u>	<u>Germination</u>
Annual Rye	10%	98%	95%
*Perennial Rye	30%	98%	95%
Creeping Red Fescue	20%	98%	95%
**Turf Type Fescue	40%	98%	95%

*Note: Provide a minimum of two varieties of Perennial Rye from the following list. Affinity, APM, Buccaneer, Nighthawk, Partner, Saturn, Seville.

**Note: Provide a minimum of two varieties of Turf Type Tall Fescue from the following list: Jubilee, Veranda, Morgan, Stagecoach.

END OF SECTION 329200

SECTION 334000 – STORM SEWER UTILITIES

PART 1 - GENERAL

1.1 DESCRIPTION

This section specifies materials and procedures for construction of outside, underground storm sewer systems that are complete and ready for operation. This includes piping, structures and all other incidentals.

1.2 RELATED WORK

- A. Excavation, Trench Widths, Pipe Bedding, Backfill, Shoring, Sheeting, Bracing: Section 312000, EARTH MOVING.
- B. Concrete Work, Reinforcing, Placement and Finishing: Section 033000, CAST-IN-PLACE CONCRETE.

1.3 DEFINITIONS

1.4 ABBREVIATIONS

- A. HDPE: High-density polyethylene
- B. PE: Polyethylene

1.5 DELIVERY, STORAGE, AND HANDLING

- A. Do not store plastic manholes, pipe, and fittings in direct sunlight.
- B. Handle manholes, catch basins, and storm water inlets according to manufacturer's written rigging instructions.

1.6 COORDINATION

- A. Coordinate connection to storm sewer main with the owner.
- B. Coordinate exterior utility lines and connections to building services up to the actual extent of building wall.

1.7 QUALITY ASSURANCE:

- A. Products Criteria:
 - 1. When two or more units of the same type or class of materials or equipment are required, these units shall be products of one manufacturer.

2. A nameplate bearing manufacturer's name or trademark, including model number, shall be securely affixed in a conspicuous place on equipment. In addition, the model number shall be either cast integrally with equipment, stamped, or otherwise permanently marked on each item of equipment.

1.8 SUBMITTALS

- A. Manufacturers' Literature and Data shall be submitted, as one package, for pipes, fittings and appurtenances, including jointing materials, hydrants, valves and other miscellaneous items.

1.9 APPLICABLE PUBLICATIONS

- A. The publications listed below form a part of this specification to the extent referenced. The publications are referenced in the text by the basic designation only.
- B. American Society for Testing and Materials (ASTM):
 - A185/A185M-07 Steel Welded Wire Reinforcement, Plain, for Concrete
 - A242/A242M-04(2009) High-Strength Low-Alloy Structural Steel
 - A536-84(2009) Ductile Iron Castings
 - A615/A615M-09b Deformed and Plain Carbon-Steel Bars for Concrete Reinforcement
 - A929/A929M-01(2007) Steel Sheet, Metallic-Coated by the Hot-Dip Process for Corrugated Steel Pipe
 - C14-07 Non-reinforced Concrete Sewer, Storm Drain, and Culvert Pipe
 - C33/C33M-08 Concrete Aggregates
 - C76-11 Reinforced Concrete Culvert, Storm Drain, and Sewer Pipe
 - C139-10 Concrete Masonry Units for Construction of Catch Basins and Manholes
 - C150/C150M-11 Portland Cement
 - C443-10 Joints for Concrete Pipe and Manholes, Using Rubber Gaskets
 - C478-09 Precast Reinforced Concrete Manhole Sections
 - C506-10b Reinforced Concrete Arch Culvert, Storm Drain, and Sewer Pipe
 - C857-07 Minimum Structural Design Loading for Underground Precast Concrete Utility Structures
 - C891-09 Installation of Underground Precast Concrete Utility Structures

C913-08	Precast Concrete Water and Wastewater Structures
C923-08	Resilient Connectors Between Reinforced Concrete Manhole Structures, Pipes, and Laterals
C990-09	Joints for Concrete Pipe, Manholes, and Precast Box Sections Using Preformed Flexible Joint Sealants
C1103-03(2009)	Joint Acceptance Testing of Installed Precast Concrete Pipe Sewer Lines
C1173-08	Flexible Transition Couplings for Underground Piping Systems
C1479-10	Installation of Precast Concrete Sewer, Storm Drain, and Culvert Pipe Using Standard Installations
D448-08	Sizes of Aggregate for Road and Bridge Construction
D698-07e1	Laboratory Compaction Characteristics of Soil Using Standard Effort (12 400 ft-lbf/ft ³ (600 kN-m/m ³))
D1056-07	Flexible Cellular Materials—Sponge or Expanded Rubber
D1785-06	Poly(Vinyl Chloride) (PVC) Plastic Pipe, Schedules 40, 80, and 120
D3034-08	Type PSM Poly(Vinyl Chloride) (PVC) Sewer Pipe and Fittings
D3350-10	Polyethylene Plastics Pipe and Fittings Materials
D5926-09	Poly (Vinyl Chloride) (PVC) Gaskets for Drain, Waste, and Vent (DWV), Sewer, Sanitary, and Storm Plumbing Systems
F477-10.....	Elastomeric Seals (Gaskets) for Joining Plastic Pipe
F679-08.....	Poly(Vinyl Chloride) (PVC) Large-Diameter Plastic Gravity Sewer Pipe and Fittings
F714-10.....	Polyethylene (PE) Plastic Pipe (SDR-PR) Based on Outside Diameter
F794-03(2009).....	Poly(Vinyl Chloride) (PVC) Profile Gravity Sewer Pipe and Fittings Based on Controlled Inside Diameter
F891-10.....	Coextruded Poly(Vinyl Chloride) (PVC) Plastic Pipe With a Cellular Core
F894-07.....	Polyethylene (PE) Large Diameter Profile Wall Sewer and Drain Pipe
F949-10.....	Poly(Vinyl Chloride) (PVC) Corrugated Sewer Pipe With a Smooth Interior and Fittings
F1417-11.....	Installation Acceptance of Plastic Gravity Sewer Lines Using Low-Pressure Air
F1668-08.....	Construction Procedures for Buried Plastic Pipe

- C. American Association of State Highway and Transportation Officials (AASHTO):
 - M198-10 Joints for Concrete Pipe, Manholes, and Precast Box Sections Using Preformed Flexible Joint Sealants
 - M252-09 Corrugated Polyethylene Drainage Pipe
 - M294-10 Corrugated Polyethylene Pipe, 12 to 60 In. (300 to 1500 mm) Diameter
- D. American Water Works Association(AWWA):
 - C900-07 Polyvinyl Chloride (PVC) Pressure Pipe and Fabricated Fittings, 4 In. Through 12 In. (100 mm Through 300 mm), for Water Transmission and Distribution
 - M23-2nd ed PVC Pipe "Design And Installation"
- E. American Society of Mechanical Engineers (ASME):
 - A112.6.3-2001 Floor and Trench Drains
 - A112.14.1-2003 Backwater Valves
 - A112.36.2M-1991 Cleanouts
- F. American Concrete Institute (ACI):
 - 318-05 Structural Commentary and Commentary
 - 350/350M-06 Environmental Engineering Concrete Structures and Commentary
- G. National Stone, Sand and Gravel Association (NSSGA): Quarried Stone for Erosion and Sediment Control

1.10 WARRANTY

The Contractor shall remedy any defect due to faulty material or workmanship and pay for any damage to other work resulting there from within a period of one year from final acceptance. Further, the Contractor will furnish all manufacturers' and suppliers' written guarantees and warranties covering materials and equipment furnished under this Contract.

PART 2 - PRODUCTS

2.1 FACTORY-ASSEMBLED PRODUCTS

- A. Standardization of components shall be maximized to reduce spare part requirements. The Contractor shall guarantee performance of assemblies of components, and shall repair or replace elements of the assemblies as required to deliver specified performance of the complete assembly.

2.2 PE PIPE AND FITTINGS

- A. Corrugated PE drainage pipe and fittings, NPS 3 to NPS 10 (DN 80 to DN 250); ASTM F714, SDR 21 with smooth waterway for coupling joints.
 - 1. Soil-tight Couplings: AASHTO M252, corrugated, matching tube and fittings.
- B. Corrugated PE pipe and fittings, NPS 12 to NPS 60 (DN 300 to DN 1500); AASHTO M294, Type S or ASTM F714, SDR 21 for pipes 3 to 24 inches (300 to 600 mm) with smooth waterway for coupling joints. Pipe shall be produced from PE certified by the resin producer as meeting the requirements of ASTM D3350, minimum cell class 335434C.
 - 1. Soil-tight Couplings: AASHTO M252, corrugated, matching tube and fittings.
- C. Profile Wall PE Pipe: Pipe shall comply with ASTM F894, Class 160.
 - 1. Profile Wall PE Plastic Pipe Joints: Joints shall be as per ASTM F894, gasket type with integral bell.
- D. PVC Pipe And Fittings
 - 1. PVC Cellular-Core Pipe And Fittings: ASTM F891, Sewer and Drain Series, PS 50 minimum stiffness, PVC cellular-core pipe with plain ends for solvent-cemented joints.
 - 2. Fittings: ASTM D3034, SDR 35, PVC socket-type fittings.
- E. PVC Corrugated Sewer Piping
 - 1. Pipe: ASTM F949, PVC, corrugated pipe with bell-and-spigot ends for gasketed joints.
 - 2. Fittings: ASTM F949, PVC molded or fabricated, socket type.
 - 3. Gaskets: ASTM F477, elastomeric seals.
- F. PVC Profile Sewer Piping
 - 1. Pipe: ASTM F794, PVC profile, gravity sewer pipe with bell-and-spigot ends.
 - 2. Fittings: ASTM D3034, PVC with bell ends.
 - 3. Gaskets: ASTM F477, elastomeric seals.
- G. PVC Type PSM Sewer Piping
 - 1. Pipe: ASTM D3034, SDR 35, PVC Type PSM sewer pipe with bell-and-spigot ends.
 - 2. Fittings: ASTM D3034, PVC with bell ends.
 - 3. Gaskets: ASTM F477, elastomeric seals.
- H. PVC Gravity Sewer Piping
 - 1. Pipe and fittings shall be ASTM F679, T-1 wall thickness, PVC gravity sewer pipe with bell-and-spigot ends.
 - 2. Gaskets: ASTM F477, elastomeric seals for gasketed joints.

2.3 CONCRETE PIPE AND FITTINGS

- A. Non-Reinforced-Concrete sewer pipe and fittings shall be ASTM C14, Class 3, with bell-and-spigot ends and gasketed joints with ASTM C443, rubber gaskets.
- B. Reinforced-Concrete sewer pipe and fittings shall be ASTM C76 or ASTM C655.
 - 1. Bell-and-spigot ends and gasketed joints with ASTM C443, rubber gaskets.
 - 2. Class III: Wall A

2.4 NONPRESSURE TRANSITION COUPLINGS

- A. Comply with ASTM C1173, elastomeric, sleeve-type, reducing or transition coupling, for joining underground non-pressure piping. Include ends of same sizes as piping to be joined, and corrosion-resistant-metal tension band and tightening mechanism on each end.
- B. Sleeve Materials
 - 1. For concrete pipes: ASTM C443, rubber.
 - 2. For plastic pipes: ASTM F477, elastomeric seal or ASTM D5926, PVC.
 - 3. For dissimilar pipes: ASTM D5926, PVC or other material compatible with pipe materials being joined.
- C. Unshielded, Flexible Couplings: Couplings shall be an elastomeric sleeve with corrosion-resistant-metal tension band and tightening mechanism on each end.
- D. Shielded, flexible couplings shall be elastomeric or rubber sleeve with full-length, corrosion-resistant outer shield and corrosion-resistant-metal tension band and tightening mechanism on each end.
- E. Ring-Type, flexible couplings shall be elastomeric compression seal with dimensions to fit inside bell of larger pipe and for spigot of smaller pipe to fit inside ring.

2.5 CLEANOUTS

- A. Cast-Iron Cleanouts: ASME A112.36.2M, round, gray-iron housing with clamping device and round, secured, scoriated, gray-iron cover. Include gray-iron ferrule with inside calk or spigot connection and countersunk, tapered-thread, brass closure plug.
 - 1. Top-Loading Classification(s): Heavy Duty
 - 2. Pipe fitting and riser to cleanout shall be same material as main pipe line.
- B. Plastic Cleanouts shall have PVC body with PVC threaded plug. Pipe fitting and riser to cleanout shall be of same material as main line pipe.

2.6 DRAINS

- A. Cast-Iron Area Drains: ASME A112.6.3, gray-iron round body with anchor flange and round grate. Include bottom outlet with inside calk or spigot connection, of sizes indicated.
 - 1. Top-Loading Classification(s): Medium and Heavy Duty
- B. Cast-Iron Trench Drains: ASME A112.6.3, 6 inch (150 mm) wide top surface, rectangular body with anchor flange or other anchoring device, and rectangular grate. Include units of total length indicated and quantity of bottom outlets with inside calk or spigot connections, of sizes indicated.
 - 1. Top-Loading Classification(s): Heavy and Extra-Heavy Duty
- C. Steel Trench Drains: ASTM A242, welded steel plate, to form rectangular body with uniform bottom downward slope of 2 percent toward outlet, anchor flange, and grate.
 - 1. Plate Thicknesses: 1/4 inch (6.4 mm)
 - 2. Overall Widths: 7-1/2 inches (190 mm) and 12-1/3 inches (313 mm)
- D. Grate openings shall be 3/8 by 3 inch (9.5 by 76 mm) slots.

2.7 MANHOLES AND CATCH BASINS

- A. Standard Precast Concrete Manholes:
 - 1. Description: ASTM C478 (ASTM C478M), precast, reinforced concrete, of depth indicated, with provision for sealant joints.
 - 2. Diameter: 48 inches (1200 mm) minimum unless otherwise indicated.
 - 3. Ballast: Increase thickness of precast concrete sections or add concrete to base section as required to prevent flotation.
 - 4. Base Section: 6 inch (150 mm) minimum thickness for floor slab and 4-inch (102 mm) minimum thickness for walls and base riser section, and separate base slab or base section with integral floor.
 - 5. Riser Sections: 4 inch (102 mm) minimum thickness, and lengths to provide depth indicated.
 - 6. Top Section: Eccentric-cone type unless concentric-cone or flat-slab-top type is indicated, and top of cone of size that matches grade rings.
 - 7. Joint Sealant: ASTM C990 (ASTM C990M), bitumen or butyl rubber.
 - 8. Resilient Pipe Connectors: ASTM C923 (ASTM C923M), cast or fitted into manhole walls, for each pipe connection.
 - 9. Steps: If total depth from floor of manhole to finished grade is greater than 60 inches (1500 mm). Individual FRP steps or ASTM A615, deformed, 1/2 inch (13 mm) steel reinforcing rods encased in ASTM D4101, PP, width of 16 inches (400 mm) minimum, spaced at 12 to 16 inch (300 to 400 mm) intervals.

10. Adjusting Rings: Reinforced-concrete rings, 6 to 9 inch (150 to 225 mm) total thickness, to match diameter of manhole frame and cover, and height as required to adjust manhole frame and cover to indicated elevation and slope.

B. Designed Precast Concrete Manholes:

1. Description: ASTM C913; designed for A-16 (AASHTO HS20-44), heavy-traffic, structural loading; of depth, shape, and dimensions indicated, with provision for sealant joints.
2. Ballast: Increase thickness of one or more precast concrete sections or add concrete to manhole as required to prevent flotation.
3. Joint Sealant: ASTM C990 (ASTM C990M), bitumen or butyl rubber.
4. Resilient Pipe Connectors: ASTM C923 (ASTM C923M), cast or fitted into manhole walls, for each pipe connection.
5. Steps: If total depth from floor of manhole to finished grade is greater than 60 inches (1500 mm). Individual FRP steps or ASTM A615 deformed, 1/2 inch (13 mm) steel reinforcing rods encased in ASTM D 4101, PP, width of 16 inches (400 mm) minimum, spaced at 12 to 16 inch (300 to 400 mm) intervals.
6. Adjusting Rings: Reinforced-concrete rings, 6 to 9 inch (150 to 225 mm) total thickness, to match diameter of manhole frame and cover, and height as required to adjust manhole frame and cover to indicated elevation and slope.

C. Manhole Frames and Covers:

1. Description: Ferrous; 24 inch (610 mm) ID by 7 to 9 inch (175 to 225 mm) riser with 4 inch (102 mm) minimum width flange and 26-inch (600 mm) diameter cover. Include indented top design with lettering cast into cover, using wording equivalent to "STORM SEWER."
2. Material: ASTM A536, Grade 60-40-18 ductile iron, unless otherwise indicated.

2.8 CONCRETE FOR MANHOLES AND CATCH BASINS

A. General: Cast-in-place concrete according to ACI 318, ACI 350/350R, and the following:

1. Cement: ASTM C150, Type II.
2. Fine Aggregate: ASTM C33, sand.
3. Coarse Aggregate: ASTM C33, crushed gravel.
4. Water: Potable.

B. Concrete Design Mix: 4000 psi (27.6 MPa) minimum, compressive strength in 28 days.

1. Reinforcing Fabric: ASTM A185, steel, welded wire fabric, plain.
2. Reinforcing Bars: ASTM A615, Grade 60 (420 MPa) deformed steel.

C. Manhole Channels and Benches: Channels shall be the main line pipe material. Include benches in all manholes and catch basins.

1. Channels: Main line pipe material or concrete invert. Height of vertical sides to three-fourths of pipe diameter. Form curved channels with smooth, uniform radius

and slope. Invert Slope: Same slope as the main line pipe. Bench to be concrete, sloped to drain into channel. Minimum of 6 inch slope from main line pipe to wall sides.

2.9 POLYMER-CONCRETE, CHANNEL DRAINAGE SYSTEMS

- A. General Requirements for Polymer-Concrete, Channel Drainage Systems: Modular system of precast, polymer-concrete channel sections, grates, and appurtenances; designed so grates fit into channel recesses without rocking or rattling. Include quantity of units required to form total lengths indicated.
- B. Sloped-Invert, Polymer-Concrete Systems:
 - 1. Channel Sections:
 - a. Interlocking-joint, precast, modular units with end caps.
 - b. 4-inch (102 mm) inside width and deep, rounded bottom, with built-in invert slope of 0.6 percent and with outlets in quantities, sizes, and locations indicated.
 - c. Extension sections necessary for required depth.
 - d. Frame: Include gray-iron or steel frame for grate.
 - 2. Grates:
 - a. Manufacturer's designation "Heavy Duty," with slots or perforations that fit recesses in channels.
 - b. Material: Gray iron.
 - 3. Covers: Solid gray iron if indicated.
 - 4. Locking Mechanism: Manufacturer's standard device for securing grates to channel sections.
- C. Narrow-Width, Level-Invert, Polymer-Concrete Systems:
 - 1. Channel Sections:
 - a. Interlocking-joint, precast, modular units with end caps.
 - b. 5 inch (127 mm) inside width and 9-3/4 inch (248 mm) deep, rounded bottom, with level invert and with NPS 4 (DN 100) outlets in quantities, sizes, and locations indicated.
 - 2. Grates:
 - a. Slots or perforations that fit recesses in channels.
 - b. Material: Gray iron.
 - 3. Covers: Solid gray iron if indicated.
 - 4. Locking Mechanism: Manufacturer's standard device for securing grates to channel sections.
- D. Wide-Width, Level-Invert, Polymer-Concrete Systems:
 - 1. Channel Sections:
 - a. Interlocking-joint, precast, modular units with end caps.
 - b. 8 inch (203 mm) inside width and 13-3/4 inch (350 mm) deep, rounded bottom, with level invert and with outlets in quantities, sizes, and locations indicated.

2. Grates:
 - a. Slots or other openings that fit recesses in channels.
 - b. Material: Gray iron.
 3. Covers: Solid gray iron if indicated.
 4. Locking Mechanism: Manufacturer's standard device for securing grates to channel sections.
- E. Drainage Specialties: Precast, polymer-concrete units.
1. Large Catch Basins:
 - a. 24 by 12 inch (610 by 305-mm) polymer-concrete body, with outlets in quantities and sizes indicated.
 - b. Gray-iron slotted grate.
 - c. Frame: Include gray-iron or steel frame for grate.
 2. Small Catch Basins:
 - a. 19 to 24 inch by approximately 6 inch (483 to 610 mm by approximately 150 mm) polymer-concrete body, with outlets in quantities and sizes indicated.
 - b. Gray-iron slotted grate.
 - c. Frame: Include gray-iron or steel frame for grate.
 3. Oil Interceptors:
 - a. Polymer-concrete body with interior baffle and four steel support channels and two 1/4 inch (6.4 mm) thick, steel-plate covers.
 - b. Steel-plate covers.
 - c. Capacity: 140 gal. (530 L).
 - d. Inlet and Outlet: NPS 4 (DN 100).
 4. Sediment Interceptors:
 - a. 27 inch (686 mm) square, polymer-concrete body, with outlets in quantities and sizes indicated.
 - b. 24 inch (610 mm) square, gray-iron frame and slotted grate.
- F. Supports, Anchors, and Setting Devices: Manufacturer's standard unless otherwise indicated.
- G. Channel-Section Joining and Fastening Materials: As recommended by system manufacturer.

2.10 PLASTIC, CHANNEL DRAINAGE SYSTEMS

- A. General Requirements for Plastic, Channel Drainage Systems:
1. Modular system of plastic channel sections, grates, and appurtenances.
 2. Designed so grates fit into frames without rocking or rattling.
 3. Number of units required to form total lengths indicated.
- B. Fiberglass Systems:

1. Channel Sections:
 - a. Interlocking-joint, fiberglass modular units, with built-in invert slope of approximately 1 percent and with end caps.
 - b. Rounded or inclined inside bottom surface, with outlets in quantities, sizes, and locations indicated.
 - c. Width: 6 or 8 inches (150 or 203 mm).
 2. Factory- or field-attached frames that fit channel sections and grates.
 - a. Material: Manufacturer's standard metal.
 3. Grates with slots or perforations that fit frames.
 - a. Material: Gray iron.
 4. Covers: Solid gray iron if indicated.
 5. Drainage Specialties:
 - a. Large Catch Basins: 24 inch (610 mm) square plastic body, with outlets in quantities and sizes indicated. Include gray-iron frame and slotted grate.
 - b. Small Catch Basins: 12 by 24 inch (305 by 610 mm) plastic body, with outlets in quantities and sizes indicated. Include gray-iron frame and slotted grate.
- C. PE Systems:
1. Channel Sections: Interlocking-joint, PE modular units, 4 inches (102 mm) wide, with end caps. Include rounded bottom, with level invert and with outlets in quantities, sizes, and locations indicated.
 2. Grates: PE, ladder shaped; with stainless-steel screws.
 3. Color: Gray unless otherwise indicated.
 4. Drainage Specialties: Include the following PE components:
 - a. Drains: 4 inch (102 mm) diameter, round, slotted top; with NPS 4 (DN 100) bottom outlet.
 - b. Drains: 8 inch (203 mm) diameter, round, slotted top; with NPS 6 (DN 150) bottom outlet.
 - c. Drains: 4 inch (102 mm) square, slotted top; with NPS 3 (DN 80) bottom outlet.
 - d. Drains: 8 inch (203 mm) square, slotted top; with NPS 6 (DN 150) bottom outlet.
 - e. Catch Basins: 12 inch (305 mm) square plastic body, with outlets in quantities and sizes indicated. Include PE slotted grate 11-3/4 inches (298 mm) square by 1-1/8 inches (28.6 mm) thick.
- D. Supports, Anchors, and Setting Devices: Manufacturer's standard unless otherwise indicated.
- E. Channel-Section Joining and Fastening Materials: As recommended by system manufacturer.

2.11 RESILIENT CONNECTORS AND DOWNSPOUT BOOTS FOR BUILDING ROOF DRAINS

- A. Resilient connectors and downspout boots: Flexible, watertight connectors used for connecting pipe to manholes and inlets and shall conform to ASTM C923.

PART 3 - EXECUTION

3.1 PIPE BEDDING

- A. The bedding surface of the pipe shall provide a firm foundation of uniform density throughout the entire length of pipe. Concrete pipe requirements are such that when no bedding class is specified, concrete pipe shall be bedded in a soil foundation accurately shaped and rounded to conform with the lowest one-fourth of the outside portion of circular pipe. When necessary, the bedding shall be tamped. Bell holes and depressions for joints shall not be more than the length, depth, and width required for properly making the particular type of joint. Plastic pipe bedding requirements shall meet the requirements of ASTM D2321. Bedding, haunching and initial backfill shall be either Class IB or Class II material. Corrugated metal pipe bedding requirements shall conform to ASTM A798.

3.2 PIPING INSTALLATION

- A. Drawing plans and details indicate general location and arrangement of underground storm drainage piping. Install piping as indicated, to extent practical. Where specific installation is not indicated, follow piping manufacturer's written instructions.
- B. Install piping with 24 inch (660 mm) minimum cover as shown on the Drawings.
- C. Install piping beginning at low point, true to grades and alignment indicated with unbroken continuity of invert. Place bell ends of piping facing upstream. Install gaskets, seals, sleeves, and couplings according to manufacturer's written instructions for use of lubricants, cements, and other installation requirements.
 - 1. Do not lay pipe on unstable material, in wet trench or when trench and weather conditions are unsuitable for the work.
 - 2. Support pipe on compacted bedding material. Excavate bell holes only large enough to properly make the joint.
 - 3. Inspect pipes and fittings, for defects before installation. Defective materials shall be plainly marked and removed from the site. Cut pipe shall have smooth regular ends at right angles to axis of pipe.
 - 4. Clean interior of all pipe thoroughly before installation. When work is not in progress, open ends of pipe shall be closed securely to prevent entrance of storm water, dirt or other substances.

5. Lower pipe into trench carefully and bring to proper line, grade, and joint. After jointing, interior of each pipe shall be thoroughly wiped or swabbed to remove any dirt, trash or excess jointing materials.
 6. Do not walk on pipe in trenches until covered by layers of shading to a depth of 12 inches (300 mm) over the crown of the pipe.
 7. Warning tape shall be continuously placed 12 inches (300 mm) above storm sewer piping.
- D. Install manholes for changes in direction unless fittings are indicated. Use fittings for branch connections unless direct tap into existing sewer is indicated.
- E. Install proper size increasers, reducers, and couplings where different sizes or materials of pipes and fittings are connected. Reducing size of piping in direction of flow is prohibited.
- F. When installing pipe under streets or other obstructions that cannot be disturbed, use pipe-jacking process of microtunneling.
- G. Install gravity-flow, nonpressure drainage piping according to the following:
1. Install piping pitched down in direction of flow.
 2. Install piping NPS 6 (DN 150) and larger with restrained joints at tee fittings and at changes in direction. Use corrosion-resistant rods, pipe or fittings; or cast in-place concrete supports or anchors.
 3. Install PE corrugated sewer piping according to ASTM D2321 with gasketed joints.
 4. Install PVC cellular-core piping, PVC sewer piping, and PVC profile gravity sewer piping, according to ASTM D2321 and ASTM F1668.
 5. Install non-reinforced-concrete and reinforced concrete sewer piping according to ASTM C1479.

3.3 REGRADING

- A. Raise or lower existing manholes and structures frames and covers in regraded areas to finish grade. Carefully remove, clean and salvage cast iron frames and covers. Adjust the elevation of the top of the manhole or structure as detailed on the drawings. Reset cast iron frame and cover, grouting below and around the frame. Install concrete collar around reset frame and cover as specified for new construction.
- B. During periods when work is progressing on adjusting manholes or structures cover elevations, the Contractor shall install a temporary cover above the bench of the structure or manhole. The temporary cover shall be installed above the high flow elevation within the structure, and shall prevent debris from entering the wastewater stream.

3.4 CONNECTIONS TO EXISTING MANHOLES

- A. Make pipe connections and alterations to existing manholes so that finished work will conform as nearly as practicable to the applicable requirements specified for new manholes, including concrete and masonry work, cutting, and shaping.

3.5 DRAIN INSTALLATION

- A. Install type of drains in locations indicated.
 - 1. Use Light-Duty, top-loading classification cleanouts in earth or unpaved foot-traffic areas.
 - 2. Use Medium-Duty, top-loading classification cleanouts in paved foot-traffic areas.
 - 3. Use Heavy-Duty, top-loading classification cleanouts in vehicle-traffic service areas.
 - 4. Use Extra-Heavy-Duty, top-loading classification cleanouts in roads and truck dock location.
- B. Embed drains in 4 inch (102 mm) minimum concrete around bottom and sides.
- C. Set drain frames and covers with tops flush with pavement surface.
- D. Assemble trench sections with flanged joints and embed trench sections in 4 inch (102 mm) minimum concrete around bottom and sides.

3.6 MANHOLE INSTALLATION

- A. Install manholes, complete with appurtenances and accessories indicated. Install precast concrete manhole sections with sealants according to ASTM C891.
- B. Set tops of frames and covers flush with finished surface of manholes that occur in pavements. Set tops 3 inches (76 mm) above finished surface elsewhere unless otherwise indicated.
- C. Circular Structures:
 - 1. Precast concrete segmental blocks shall lay true and plumb. All horizontal and vertical joints shall be completely filled with mortar. Parge interior and exterior of structure with 1/2 inch (15 mm) or cement mortar applied with a trowel and finished to an even glazed surface.
 - 2. Precast reinforced concrete rings shall be installed true and plumb. The joints between rings and between rings and the base and top shall be sealed with a preform flexible gasket material specifically manufactured for this type of application. Adjust the length of the rings so that the eccentric conical top section will be at the required elevation. Cutting the conical top section is not acceptable.
 - 3. Precast reinforced concrete manhole risers and tops. Install as specified for precast reinforced concrete rings.

D. Rectangular Structures:

1. Precast concrete structures shall be placed on a 8 inch (200 mm) reinforced concrete pad, or be provided with a precast concrete base section. Structures provided with a base section shall be set on an 8 inch (200 mm) thick aggregate base course compacted to a minimum of 95 percent of the maximum density as determined by ASTM D698. Set precast section true and plumb. Seal all joints with preform flexible gasket material.
2. Do not build structures when air temperature is 32 deg F (0 deg C), or below.
3. Invert channels shall be smooth and semicircular in shape conforming to inside of adjacent sewer section. Make changes in direction of flow with a smooth curve of as large a radius as size of structure will permit. Make changes in size and grade of channels gradually and evenly. Construct invert channels by one of the listed methods:
 - a. Forming directly in concrete base of structure.
 - b. Building up with brick and mortar.
4. Floor of structure outside the channels shall be smooth and slope toward channels not less than 1 to 12 or more than 1 to 6. Bottom slab and benches shall be concrete.
5. The wall that supports access rungs or ladder shall be 90 deg vertical from the floor of structure to manhole cover.
6. Install steps and ladders per the manufacturer's recommendations. Steps and ladders shall not move or flex when used. All loose steps and ladders shall be replaced by the Contractor.
7. Install manhole frames and covers on a mortar bed, and flush with the finish pavement. Frames and covers shall not move when subject to vehicular traffic. Install a concrete collar around the frame to protect the frame from moving until the adjacent pavement is placed. In unpaved areas, the rim elevation shall be 2 inches (50 mm) above the adjacent finish grade. Install an 8 inch (203 mm) thick, by 12 inch (300 mm) concrete collar around the perimeter of the frame. Slope the top of the collar away from the frame.

3.7 CATCH BASIN INSTALLATION

- A. Construct catch basins to sizes and shapes indicated.
- B. Set frames and grates to elevations indicated.

3.8 CHANNEL DRAINAGE SYSTEM INSTALLATION

- A. Install with top surfaces of components, except piping, flush with finished surface.
- B. Assemble channel sections to form slope down toward drain outlets. Use sealants, adhesives, fasteners, and other materials recommended by system manufacturer.

- C. Embed channel sections and drainage specialties in 4 inch (102 mm) minimum concrete around bottom and sides.
- D. Assemble channel sections with flanged or interlocking joints.
- E. Embed channel sections in 4 inch (102 mm) minimum concrete around bottom and sides.

3.9 CONNECTIONS

- A. Connect non-pressure, gravity-flow drainage piping in building's storm building drains specified in Division 22 Section FACILITY STORM DRAINAGE PIPING.
- B. Encase entire connection fitting, plus 6 inch (150 mm) overlap, with not less than 6 inches (150 mm) of concrete with 28-day compressive strength of 3000 psi (20.7 MPa).
- C. Make connections to existing piping and underground manholes.
 - 1. Use commercially manufactured wye fittings for piping branch connections. Remove section of existing pipe; install wye fitting into existing piping.
 - 2. Make branch connections from side into existing piping, NPS 4 to NPS 20 (DN 100 to DN 500). Remove section of existing pipe, install wye fitting into existing piping.
 - 3. Make branch connections from side into existing piping, NPS 21 (DN 525) or larger, or to underground manholes and structures by cutting into existing unit and creating an opening large enough to allow 3 inches (76 mm) of concrete to be packed around entering connection. Cut end of connection pipe passing through pipe or structure wall to conform to shape of and be flush with inside wall unless otherwise indicated. On outside of pipe, manhole, or structure wall, use epoxy-bonding compound as interface between new and existing concrete and piping materials.
 - 4. Protect existing piping, manholes, and structures to prevent concrete or debris from entering while making tap connections. Remove debris or other extraneous material that may accumulate.
- D. Pipe couplings, expansion joints, and deflection fittings with pressure ratings at least equal to piping rating may be used in applications below unless otherwise indicated.
 - 1. Use non-pressure-type flexible couplings where required to join gravity-flow, non-pressure sewer piping unless otherwise indicated.
 - a. Unshielded flexible couplings for same or minor difference OD pipes.
 - b. Unshielded, increaser/reducer-pattern, flexible couplings for pipes with different OD.
 - c. Ring-type flexible couplings for piping of different sizes where annular space between smaller piping's OD and larger piping's ID permits installation.
 - 2. Use pressure-type pipe couplings for force-main joints.

3.10 CLOSING ABANDONED STORM DRAINAGE SYSTEMS

- A. Abandoned Piping: Close open ends of abandoned underground piping indicated to remain in place. Include closures strong enough to withstand hydrostatic and earth pressures that may result after ends of abandoned piping have been closed. Use either procedure below:
 - 1. Close open ends of piping with at least 8 inch (203 mm) thick, brick masonry bulkheads.
 - 2. Close open ends of piping with threaded metal caps, plastic plugs, or other acceptable methods suitable for size and type of material being closed. Do not use wood plugs.
- B. Abandoned Manholes and Structures: Excavate around manholes and structures as required and use one procedure below:
 - 1. Remove manhole or structure and close open ends of remaining piping.
 - 2. Remove top of manhole or structure down to at least 36 inches (915 mm) below final grade. Fill to within 12 inches (300 mm) of top with stone, rubble, gravel, or compacted dirt. Fill to top with concrete.
- C. Backfill to grade according to Division 31 Section EARTH MOVING.

3.11 IDENTIFICATION

- A. Install green warning tape directly over piping and at outside edge of underground structures.

3.12 FIELD QUALITY CONTROL

- A. Inspect interior of piping to determine whether line displacement or other damage has occurred. Prior to final acceptance, provide a video record of all piping from the building to the municipal connection to show the lines are free from obstructions, properly sloped and joined.
 - 1. Submit separate reports for each system inspection.
 - 2. Defects requiring correction include the following:
 - a. Alignment: Less than full diameter of inside of pipe is visible between structures.
 - b. Deflection: Flexible piping with deflection that prevents passage of ball or cylinder of size not less than 95 percent of piping diameter.
 - c. Damage: Crushed, broken, cracked, or otherwise damaged piping.
 - d. Infiltration: Water leakage into piping.
 - e. Exfiltration: Water leakage from or around piping.
 - 3. Replace defective piping using new materials, and repeat inspections until defects are within allowances specified.
 - 4. Reinspect and repeat procedure until results are satisfactory.

3.13 TESTING OF STORM SEWERS:

- A. Submit separate report for each test.
- B. Test new piping systems, and parts of existing systems that have been altered, extended, or repaired, for leaks and defects.
 - 1. Do not enclose, cover, or put into service before inspection and approval.
 - 2. Test completed piping systems according to requirements of authorities having jurisdiction.
 - 3. Schedule tests and inspections by authorities having jurisdiction with at least 24 hours advance notice.
 - 4. Submit separate report for each test.

3.14 CLEANING

- A. Clean interior of piping of dirt and superfluous materials.

END OF SECTION 334000



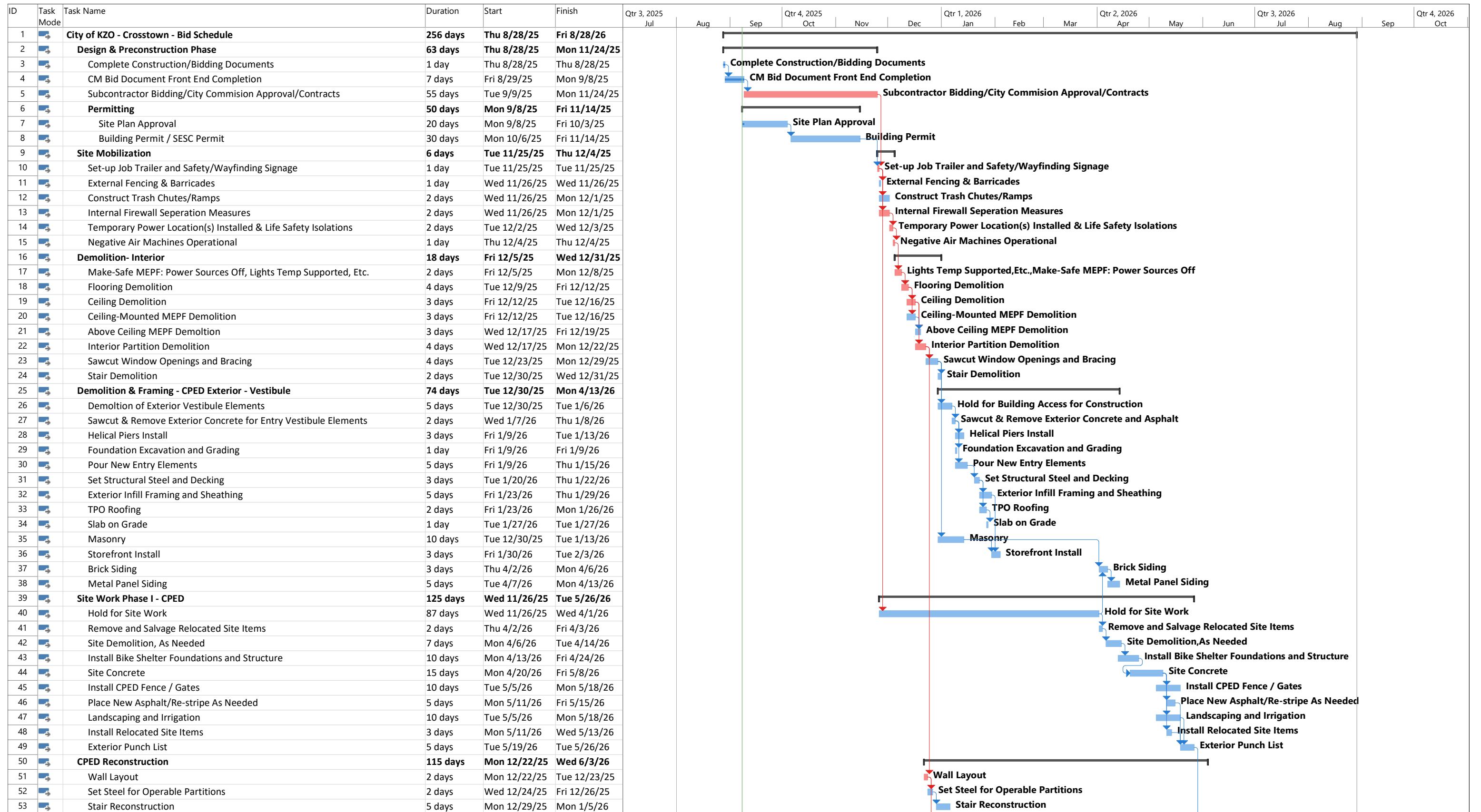
ATTACHMENT 2

BID SCHEDULE

**Electrical & Data
Crosstown Parkway Remodel**

Bid Reference #: 91082-033.0

September 2025



Project: PRELIMINARY Proposa
Date: Mon 9/8/25

Task		Project Summary		Manual Task		Start-only		Deadline		Baseline Milestone	
Split		Inactive Task		Duration-only		Finish-only		Critical		Baseline Summary	
Milestone		Inactive Milestone		Manual Summary Rollup		External Tasks		Critical Split		Progress	
Summary		Inactive Summary		Manual Summary		External Milestone		Baseline		Manual Progress	

ID	Task Mode	Task Name	Duration	Start	Finish	Qtr 3, 2025 Jul	Aug	Sep	Qtr 4, 2025 Oct	Nov	Dec	Qtr 1, 2026 Jan	Feb	Mar	Qtr 2, 2026 Apr	May	Jun	Qtr 3, 2026 Jul	Aug	Sep	Qtr 4, 2026 Oct	
54		MEPF Hangars/Overhead Rough-ins	15 days	Wed 12/24/25	Thu 1/15/26																	
55		Set Door Frames	5 days	Thu 1/8/26	Wed 1/14/26																	
56		Framing	10 days	Thu 1/8/26	Wed 1/21/26																	
57		In-wall Rough-ins	15 days	Wed 1/14/26	Tue 2/3/26																	
58		In-wall Blocking	2 days	Wed 1/28/26	Thu 1/29/26																	
59		Insulation	5 days	Mon 2/2/26	Fri 2/6/26																	
60		Hang and Finish Drywall	25 days	Thu 2/5/26	Wed 3/11/26																	
61		Lobby Elements	5 days	Thu 3/12/26	Wed 3/18/26																	
62		Shoot Ceiling Grid Wires	2 days	Tue 3/10/26	Wed 3/11/26																	
63		Prime and 1st Coat Paint	10 days	Tue 3/10/26	Mon 3/23/26																	
64		Wall Angle, Ceiling Grid, and Cut Pads	10 days	Tue 3/17/26	Mon 3/30/26																	
65		Install Ceiling Mounted Devices, Fixtures etc	15 days	Tue 3/24/26	Mon 4/13/26																	
66		Set Casework, Hang Doors, Set Operable Partitions	10 days	Tue 3/31/26	Mon 4/13/26																	
67		Flooring	20 days	Tue 4/7/26	Mon 5/4/26																	
68		Final Coat Paint	5 days	Tue 4/28/26	Mon 5/4/26																	
69		Final MEP Trim Out	5 days	Fri 5/1/26	Thu 5/7/26																	
70		Punch List Development/Completion	10 days	Thu 5/7/26	Wed 5/20/26																	
71		Construction Clean	5 days	Tue 5/12/26	Mon 5/18/26																	
72		Install Furniture and Owner Supplied Equipments	5 days	Tue 5/5/26	Mon 5/11/26																	
73		Open Up & Finish Connections to KDPS Space	4 days	Thu 5/21/26	Wed 5/27/26																	
74		Final Cleaning	5 days	Thu 5/21/26	Thu 5/28/26																	
75		Temporary Occupancy Permit- Inspections & Sign Offs	5 days	Thu 5/28/26	Wed 6/3/26																	
76		Phased Renovation of KDPS	55 days	Thu 6/4/26	Thu 8/20/26																	
77		Phase 1	6 wks	Thu 6/4/26	Thu 7/16/26																	
78		Phase 2	5 wks	Fri 7/17/26	Thu 8/20/26																	
79		KDPS Site Work	5 wks	Thu 6/4/26	Thu 7/9/26																	
80		Final Cleaning	5 days	Fri 8/14/26	Thu 8/20/26																	
81		Final Inspections	5 days	Fri 8/21/26	Thu 8/27/26																	
82		Owner Trainings	1 day	Fri 8/28/26	Fri 8/28/26																	

Project: PRELIMINARY Proposa Date: Mon 9/8/25	Task		Project Summary		Manual Task		Start-only		Deadline		Baseline Milestone	
	Split		Inactive Task		Duration-only		Finish-only		Critical		Baseline Summary	
	Milestone		Inactive Milestone		Manual Summary Rollup		External Tasks		Critical Split		Progress	
	Summary		Inactive Summary		Manual Summary		External Milestone		Baseline		Manual Progress	



ATTACHMENT 3

DRAWINGS

**Electrical & Data
Crosstown Parkway Remodel**

Bid Reference #: 91082-033.0

September 2025

City of Kalamazoo - Crosstown Facility

CPED & KDPS Workplace Renovation

150 E Crosstown Parkway Kalamazoo MI 49001

Project Team

Architect:
Intersect Studio
155 W Michigan Ave, Suite 1508,
Kalamazoo MI 49007
Phone: 269.775.1114
E-mail: lindsay@intersect-studio.com
Contact: Lindsay Reed, Project Manager

Owner:
City of Kalamazoo
150 E Crosstown Parkway, Ste. A
Kalamazoo MI 49001
Phone: 269.337.8243
Email: tibbets@kalamazoo-city.org
Contact: Ryan Tibbets

Structural Engineer
JDH Structural Engineering
3000 Ivanest SW, Suite B
Grandville MI 49418
Phone: 616.531.6020 x 3014
E-mail: dakhurst@jdheng.com
Contact: Don Akhurst

MEP Engineer
Bialosky
6555 Carnegie Ave
Cleveland OH 44103
Phone: 216.767.2093
E-mail: mhuston@bialosky.com
Contact: Mike Huston, PE

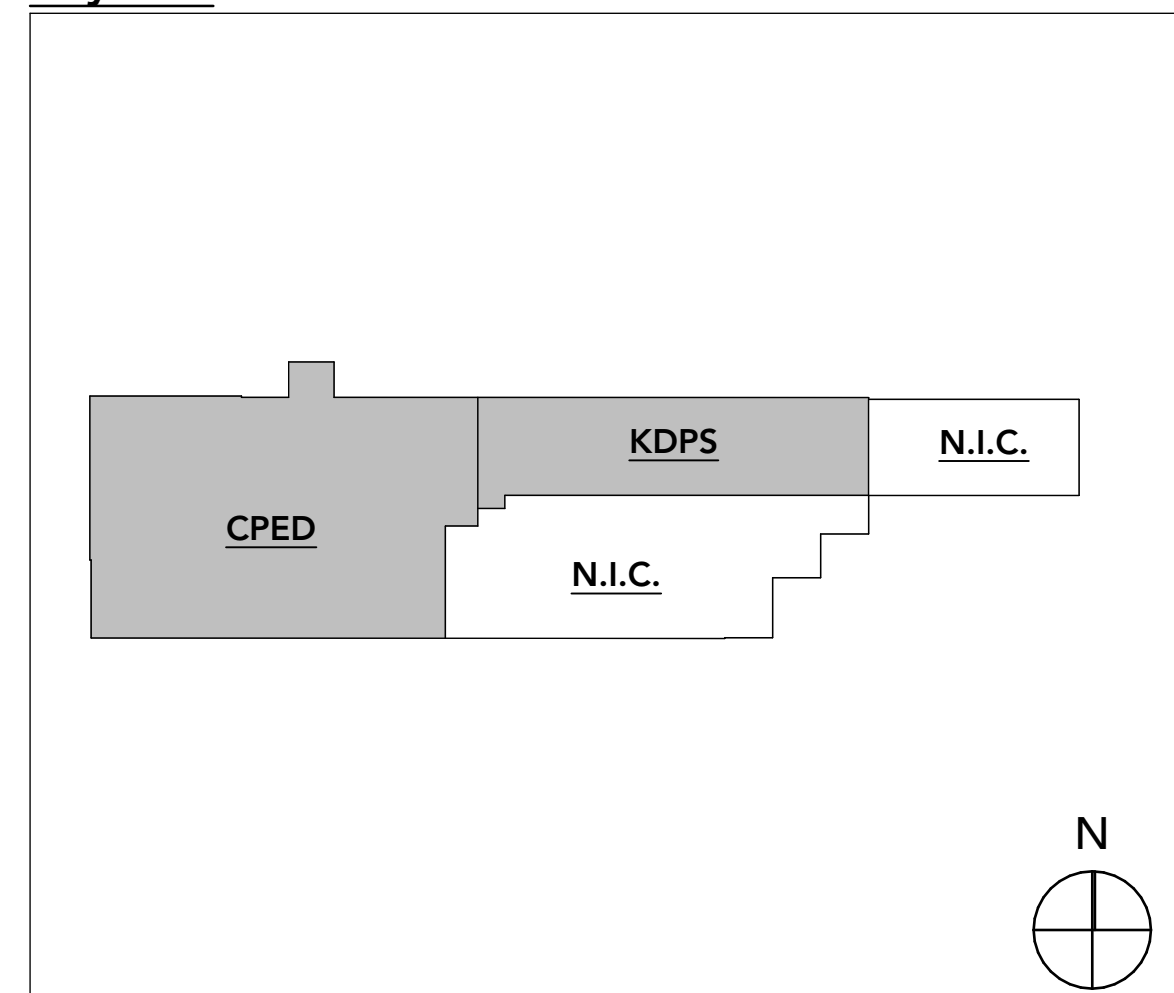
Civil Engineer
AR Engineering
5725 Venture Park Dr A
Kalamazoo MI 49009
Phone: 704.309.6841
E-mail: thom@arengineeringllc.com
Contact: Thom Carpenter

Geotechnical Evaluation
SME
3301 Tech Circle Drive
Kalamazoo MI 49008
Phone: 269.323.3555
E-mail: jeff.krusinga@sme-usa.com
Contact: Jeff Krusinga

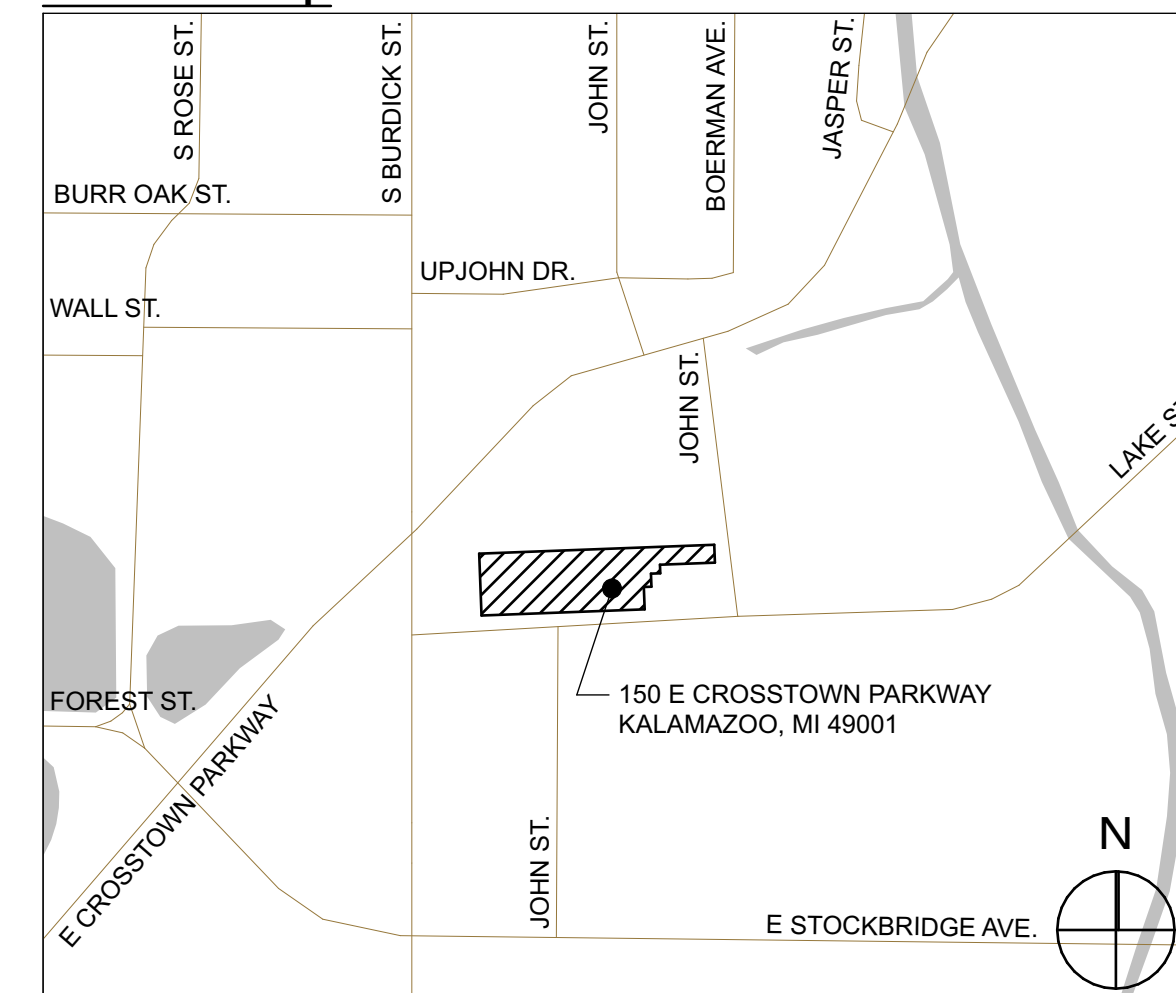


*Image for Context Only

Key Plan



Location Map



Sheet Index

General

- G001 Cover Sheet
- G002 General Notes, Code, and Specifications
- G003 Egress Plans

Architectural

- A500 Architectural Site Plan
- A501 Site Enlarged Plan & Details
- A001 Demolition Plan - Main Level CPED
- A002 Demolition Plan - Main Level KDPS
- A003 Demolition Plan - Upper Level CPED
- A100 Main Level Plan CPED
- A101 Main Level Floor Plan KDPS
- A102 Upper Level Plan CPED
- A103 Wall Types
- A104 Enlarged Floor Plans
- A105 Enlarged Stair Plan & Sections
- A106 Enlarged Toilet Room Plan and Schedule
- A107 Reflected Ceiling Main Level Plan - CPED
- A108 Reflected Ceiling Main Level Plan - KDPS
- A109 Reflected Ceiling Upper Level Plan - CPED
- A110 Lighting Schedule
- A111 Enlarged Reflected Ceiling Plans
- A112 Enlarged Reflected Ceiling Plans
- A113 Ceiling Details
- A114 Ceiling Details
- A201 Exterior Elevations
- A202 Exterior Elevations
- A301 Exterior Wall Sections
- A302 Exterior Wall Sections
- A303 Building Sections
- A304 Entry and Canopy
- A305 Entry Canopy Roof Plan
- A306 Entry Canopy Details
- A307 Entry Canopy Details
- A308 Details
- A401 Door Schedule & Details
- A402 Window Schedule & Details
- A403 Door and Window Details

Interiors

- I101 Finish Main Level Plan CPED
- I102 Finish Main Level Plan KDPS
- I103 Finish Upper Level Plan CPED
- I104 Furniture Main Level Plan CPED
- I105 Furniture Main Level Plan KDPS
- I106 Furniture Upper Level Plan CPED
- I200 Interior Elevations
- I201 Interior Elevations - CPED
- I202 Interior Elevations - KDPS
- I203 Interior Elevations - KDPS
- I301 Interior Details
- I401 Finish Schedule
- I402 Room Finish Schedule

Structural

- S001 Structural Notes
- S002 Structural Schedules
- S100 Foundation Plan - Zone A
- S101 Foundation Plan - Zone B
- S102 Second Floor Framing Plan - Zone A
- S103 Second Floor Framing Plan - Zone B
- S104 Roof Framing Plan - Zone A
- S201 Foundation Details
- S202 Foundation Details
- S301 Framing Details
- S302 Framing Details

Mechanical

- M001 Mechanical Legends & General Notes
- MD100 Main Level CPED Mechanical Demo Plan
- MD101 Main Level KDPS Mechanical Demo Plan
- MD102 Upper Level CPED Mechanical Demo Plan
- MD200 Main Level CPED HVAC Piping Demo Plan
- MD201 Main Level KDPS HVAC Piping Demo Plan
- MD202 Upper Level CPED HVAC Piping Demo Plan
- M100 Main Level CPED Mechanical Plan
- M101 Main Level KDPS Mechanical Plan
- M102 Upper Level CPED Mechanical Plan
- M200 Main Level CPED HVAC Piping Plan
- M201 Main Level KDPS HVAC Piping Plan
- M202 Upper Level CPED HVAC Piping Plan
- M501 Mechanical Details
- M601 Mechanical Schedules
- M602 Mechanical Schedules

Electrical

- E001 Electrical Legends & General Notes
- ED100 Lighting Demo Plan - Main Level CPED
- ED101 Lighting Demo Plan - Main Level KDPS
- ED102 Lighting Demo Plan - Upper Level CPED
- ED200 Power & Systems Demo Plan - Main Level CPED
- ED201 Power & Systems Demo Plan - Main Level KDPS
- ED202 Power & Systems Demo Plan - Upper Level CPED
- E100 Lighting Plan - Main Level CPED
- E101 Lighting Plan - Main Level KDPS
- E102 Lighting Plan - Upper Level CPED
- E200 Power & Systems Plan - Main Level CPED
- E201 Power & Systems Plan - Main Level KDPS
- E202 Power & Systems Plan - Upper Level CPED
- E501 Electrical Details
- E601 Electrical Schedules
- E602 Electrical Schedules
- E603 Electrical Schedules
- E604 Electrical Schedules & One Line Diagram
- E605 Electrical Panel Schedules
- E606 Electrical Panel Schedules
- E607 Electrical Panel Schedules
- E608 Electrical Panel Schedules
- E609 Electrical Panel Schedules
- E610 Electrical Panel Schedules
- ES101 Electrical Site Plan

Plumbing

- P001 Plumbing Legends & General Notes
- PD100 Main Level CPED Plumbing Demo Plan
- PD101 Main Level KDPS Plumbing Demo Plan
- PD102 Upper Level CPED Plumbing Demo Plan
- P100 Main Level CPED Plumbing Plan
- P101 Main Level KDPS Plumbing Plan
- P102 Upper Level CPED Plumbing Plan
- P103 Upper Level Mech Room Plumbing Plan
- P401 Enlarged Plumbing Plans
- P501 Plumbing Details
- P601 Plumbing Schedules

Civil

- T1.0 Title Sheet
- C1.0 Existing Conditions
- C1.1 Demolition Plan
- C2.0 Site Layout Plan
- C3.0 Details
- C3.1 Fencing Details

City of Kalamazoo - Crosstown Facility
 CPED & KDPS Workplace Renovation
 150 E Crosstown Parkway Kalamazoo MI 49001

NOT FOR
 REGULATORY
 APPROVAL,
 PERMITTING, OR
 CONSTRUCTION

Bid Set 08/21/2025
 Site Plan Review 07/31/2025
 DD Set 07/03/2025
 © 2025, intersect studio, llc
 Project Number: 23-046

Cover Sheet

G001

List of Abbreviations

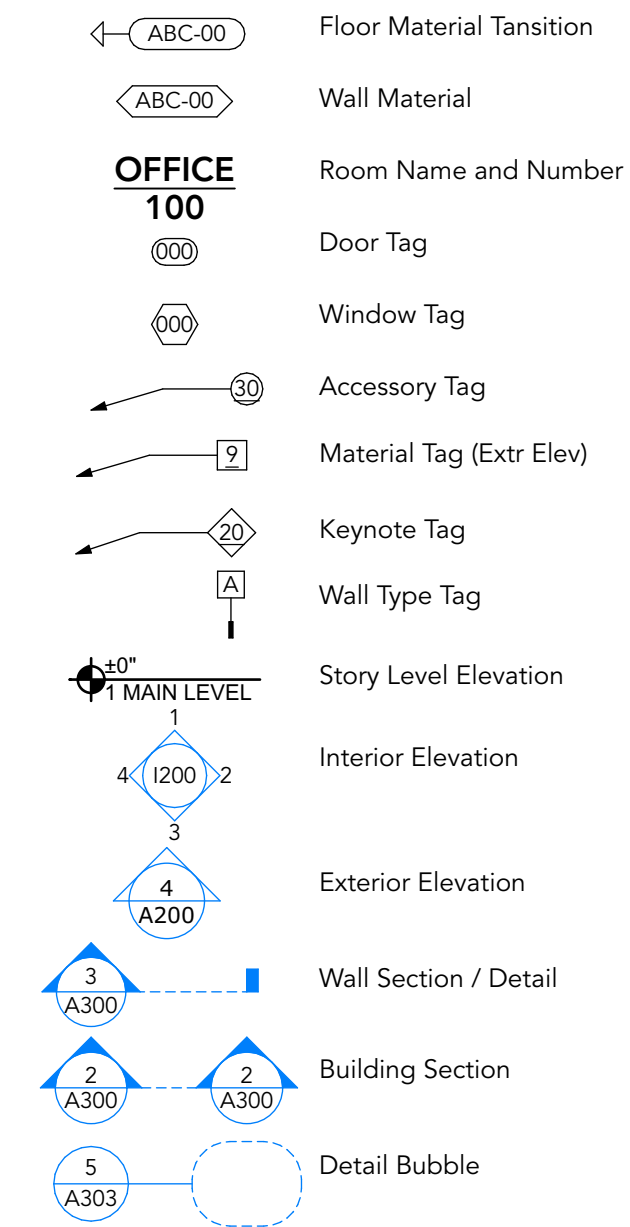
General

A/C - Air Conditioner
 AFF - Above Finish Floor
 AFG - Above Finish Grade
 BO - Bottom of
 CLG - Ceiling
 DS - Downspout
 EF - Exhaust Fan
 ELEC - Electrical
 EXT - Exterior
 GC - General Contractor
 INT - Interior
 MFR - Manufacturer
 OPP - Opposite
 PL - Property Line
 RD - Roof Drain
 REQ - Required
 RM - Room
 SAN - Sanitary
 SD - Smoke Detector
 SIM - Similar
 TO - Top of
 TYP - Typical
 UC - Under Counter
 UNO - Unless Note Otherwise
 VIF - Verify IN Field

Materials

ALUM - Aluminum
 CMU - Concrete Masonry Unit
 CPT - Carpet
 GALV - Galvanized
 GYP BD - Gypsum Board
 INS - Insulation
 LVT - Luxury Vinyl Tile
 PLY - Plywood
 PTD - Painted
 SS - Stainless Steel, Solid Surface
 WD - Wood

Symbols Legend



General Notes:

Code Compliance of Work:

- All work shall conform to all local, state, & federal laws, rules & regulations in force at the time of construction.
- Architectural work shall be in accordance with the 2015 Michigan Building Code & 2015 Michigan Rehabilitation Code for Existing Buildings.
- Electrical work shall be performed by a State of Michigan licensed Electrician according to the National Electrical Code as modified by the State of Michigan. Furnish & install all materials and labor to provide a full working electrical system.
- Plumbing work shall be performed by State of Michigan licensed Plumber according to Michigan Plumbing Code & Local Health Department. Furnish & install all materials and labor to provide a full working plumbing system.
- Heating and Air Conditioning shall be performed by State of Michigan Licensed Contractor. All heating & air conditioning shall be according to the Michigan Mechanical Code & the Michigan Energy Code. Furnish & install all materials and labor to provide a full working HVAC system.
- All work shall conform to the Michigan Barrier-Free Design Law & the Americans with Disabilities Act.

Drawings and Dimensions:

- Drawings are not to be scaled. The provided dimensions take precedence over scale.
- Contractor is responsible to verify dimensions and existing conditions. If any errors, omissions or discrepancies become apparent, these shall be brought to the attention of the architect prior to construction or ordering of equipment so that the architect may clarify or redesign as needed.
- Plan dimensions are to finished walls, typical.

Field Conditions:

- Slab or subfloor height discrepancies may exist across spaces. Once demo is complete, alert Architect of any discrepancies in uniform slab height that may affect installation of new flooring at existing finish floor height.
- The existing first floor is a structural 2-way slab spanning column line to column line, and penetrations and loading shall be limited. See S100 and S101 for notes.
- The existing second floor is a structural 2-way slab spanning column line to column line, and penetrations and loading shall be limited. See S102 for notes.
- The design team is not trained to identify asbestos. If the contractor finds any suspicious material, they should contact the Owner's environmental testing agency. All abatement should be done in accordance to Federal and State laws. Any mention of asbestos in our drawings is circumstantial & was brought to architect's attention by the contractor & should be coordinated with the contractor.
- Owner to verify locations of existing sump pumps.
- Owner shall maintain existing elevators per City of Kalamazoo & code requirements.

Gross Floor Area (Existing)

Main Level	54,350 sq ft
Upper Level	53,200 sq ft
Total Square Footage	107,550 sq ft

Gross Floor Area (Proposed)

Main Level (182 sq ft new)	54,532 sq ft
Upper Level (373 sq ft new)	53,573 sq ft
Total Gross Square Footage	108,105 sq ft

Code Review:

Applicable Codes:

- 2021 Michigan Building Code
- 2021 Michigan Rehabilitation Code for Existing Buildings
- 2021 Michigan Plumbing Code
- 2021 Michigan Mechanical Code
- 2023 National Electrical Code (NFPA 70)
- 2021 Michigan Commercial Energy Code
- Barrier Free Design: ICC/ANSI 117.1 (2017)

Building Use Group (ch 3):

- Business Group B - Civic Administration
- Assembly Group A-3 - 2nd Floor Meeting Rooms

Type of Construction (ch 6): 2B (IIB) Unprotected Non-Combustible

Combustible materials to conform with MBC section 603. FRT wood required in partitions per 603.1.1.1.

MRCEB Level 3 Alteration: No change of use

BUILDING IS FULLY SPRINKLED

Building Area (ch 5):

Multistory Sprinklered Building Occupancy B, Construction Type 2B:
 Allowable Building Area (Table 506.2): 69,000 sf
 Actual Building Area: 54,532 sf - COMPLIES

Mixed Use w/ Accessory Occupancy (ch 5, section 508.2)

Main Occupancy: B: Business
 Accessory Occupancy: A-3: Assembly <10% of floor area of each story
 1st Floor: Lobby & Meeting Room: 3,920 sf / 54,532 sf = <8% of floor
 2nd Floor: Community Meeting Room: 3,770 sf / 53,573 sf = <8% of floor

Occupancy Load (ch 10, section 1004):

Business Areas: 100 SF per person
 Assembly w/o fixed seats: 15 sf per person
 Fitness: 50 sf per person

Building Occupancy:

1st Floor West (CPED): Business (16,080 sf): 161 persons
 Assembly (3,920 sf net): 114 persons
 1st Floor East (KDPS): Business (29,338 sf): 271 persons
 2nd Floor West (CPED): Business (14,980 sf gross): 150 persons
 Assembly (3,770 sf net): 250 persons
 2nd Floor East (KDPS): Business (32,233 sf): 250 persons (existing - NIS)

First Floor Total (53,560 sf):	546 persons
Second Floor Total (52,969 sf):	650 persons
Building Total (106,529 sf):	1,221 persons

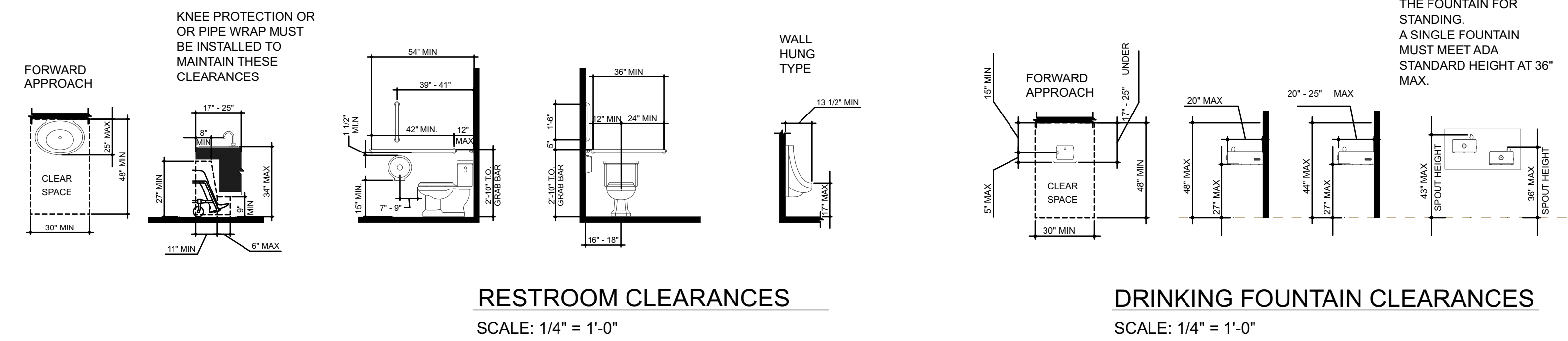
See Egress Plans on next sheet for more information

Plumbing Fixture Count (ch 29): B Business Classification

1st Floor West (CPED): 300 pp
 WC: (300p / 50) +1 = 7 WC (4 F/4 M required)
 Existing to remain: 8 F / 8 M
 Lav: (300p / 80) +1 = 5 Lav (3 F/3 M required)
 Existing to remain: 6 F / 6 M
 DF: 2 provided + filtered water provided at Work Cafe
 SS: Existing mop sink to remain

2nd Floor West (CPED): 400 pp - A Assembly Classification
 WC: (400p / 50) +1 = 9 WC (5 F/5 M required)
 Existing to remain: 5 M / 5 F + 5 Single User RR
 Lav: (400p / 80) +1 = 6 Lav (3 F/3 M required)
 Existing to remain: 3 F/3 M + 5 Single User RR
 DF: (400p / 100) = 4 required, 4 provided
 SS: Existing mop sink to remain

1st Floor East (KDPS): 271 pp
 WC: (271p / 50) +1 = 7 WC (4 F/4 M required)
 Existing to remain: 4 M / 4 F
 Lav: (271p / 80) +1 = 5 Lav (3 F/3 M required)
 Existing to remain: 3 F/2 M
 DF: 2 provided + filtered water provided at Work Cafe
 SS: Existing mop sink to remain

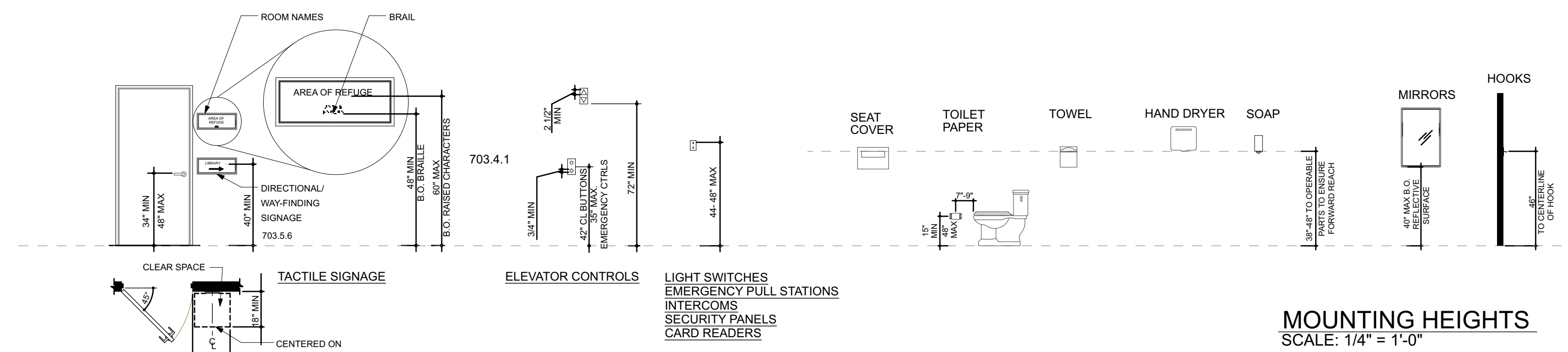


RESTROOM CLEARANCES

SCALE: 1/4" = 1'-0"

DRINKING FOUNTAIN CLEARANCES

SCALE: 1/4" = 1'-0"



MOUNTING HEIGHTS

SCALE: 1/4" = 1'-0"

NOT FOR
 REGULATORY
 APPROVAL,
 PERMITTING, OR
 CONSTRUCTION

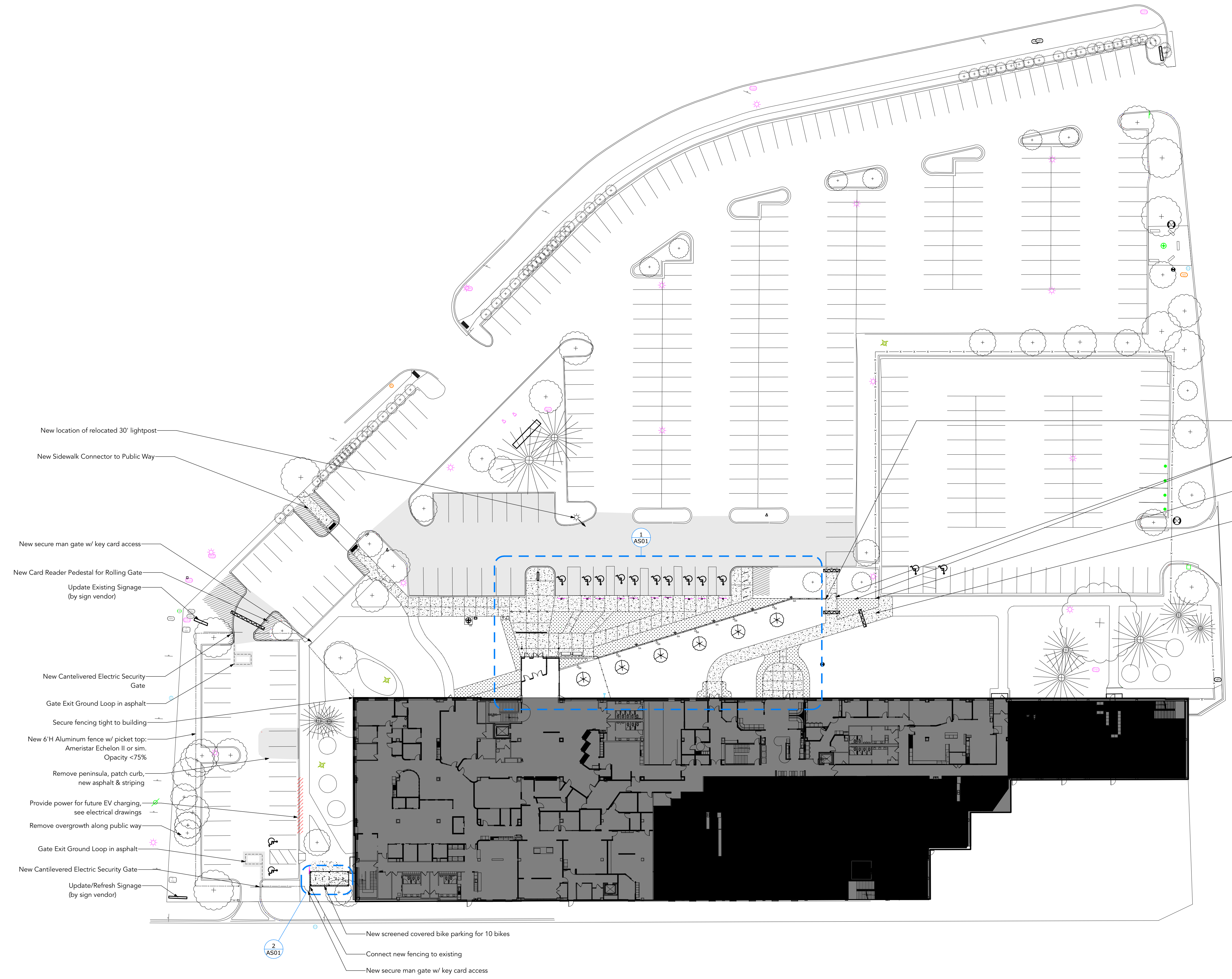
Bid Set 08/21/2025
 Site Plan Review 07/31/2025
 DD Set 07/03/2025
 © 2025, intersect studio, llc
 Project Number: 23-046

Architectural Site
 Plan

AS00

Site General Notes

- Contact "MISS DIG" at phone number 811 three (3) days prior to the start of construction, excluding Saturdays, Sundays, and holidays.
- No dimension may be scaled, refer unclear items to the architect for interpretation.
- Refer to Mechanical, Electrical, Plumbing, Structural & Civil drawings for additional site scope.
- Upon request, electronic information will be provided for site layout purposes. Contractor shall request all information in writing through intersect studio. Layout of all new construction shall be done by a licensed surveyor.
- Contractor to restore and repair any existing conditions disturbed by construction to an equal or better condition than before construction began, including buried utilities, lighting, landscaping, irrigation, etc.
- Concrete flatwork shall not pool water. Slope all pavement for proper drainage of 2% minimum, but do not exceed maximum slope as required by ADA along the accessible route, and at all accessible doors.
- All pavement, curb & gutter, sidewalk, and utilities within public right of way shall meet City of Kalamazoo standards.
- Landscaping for reference only. See Civil drawings for additional information.
- Existing irrigation system and layout to be modified as required for new sitework. Verify existing conditions and areas that will be impacted. Provide submittal showing heads and piping to be relocated where necessary, or to be added new. Provide irrigation at new landscape beds and lawn areas.



- End of privacy wall & fence, abut/connect picket fencing & man gate.
- Relocate/Rework existing secure man gate & access control & 6' H security fencing to connect between existing fencing to remain and new privacy wall & fence.
- Connect new fencing to existing.
- Vinyl fence to be salvaged. Deliver to owner.

Site Plan Key

	New Pavement
	New Asphalt & Striping
	New Landscaping Beds
	New Parking Islands and Curb
	Provide 4" dia. Schedule 40 PVC sleeve for irrigation under new hardscape

1 Architectural Site Plan
 AS00 SCALE: 1" = 30'

8/6/25 - BIMcloud: Intersect AC27 Framework Server - BIMcloud Basic for Archical 27/25/2025 Koro Crosstown Facility

NOT FOR
 REGULATORY
 APPROVAL,
 PERMITTING, OR
 CONSTRUCTION

Bid Set 08/21/2025
 Site Plan Review 07/31/2025
 DD Set 07/03/2025
 © 2025, Intersect studio, llc
 Project Number: 23-046

Site Enlarged Plan
 & Details

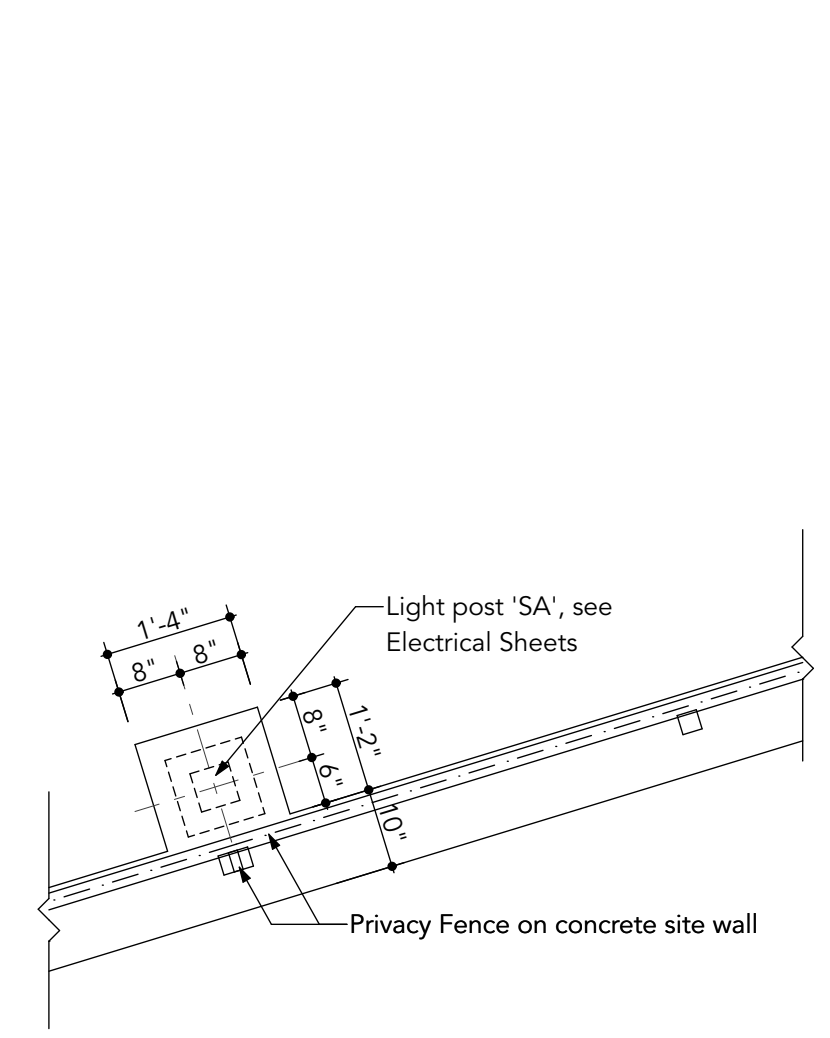
AS01

Site General Notes

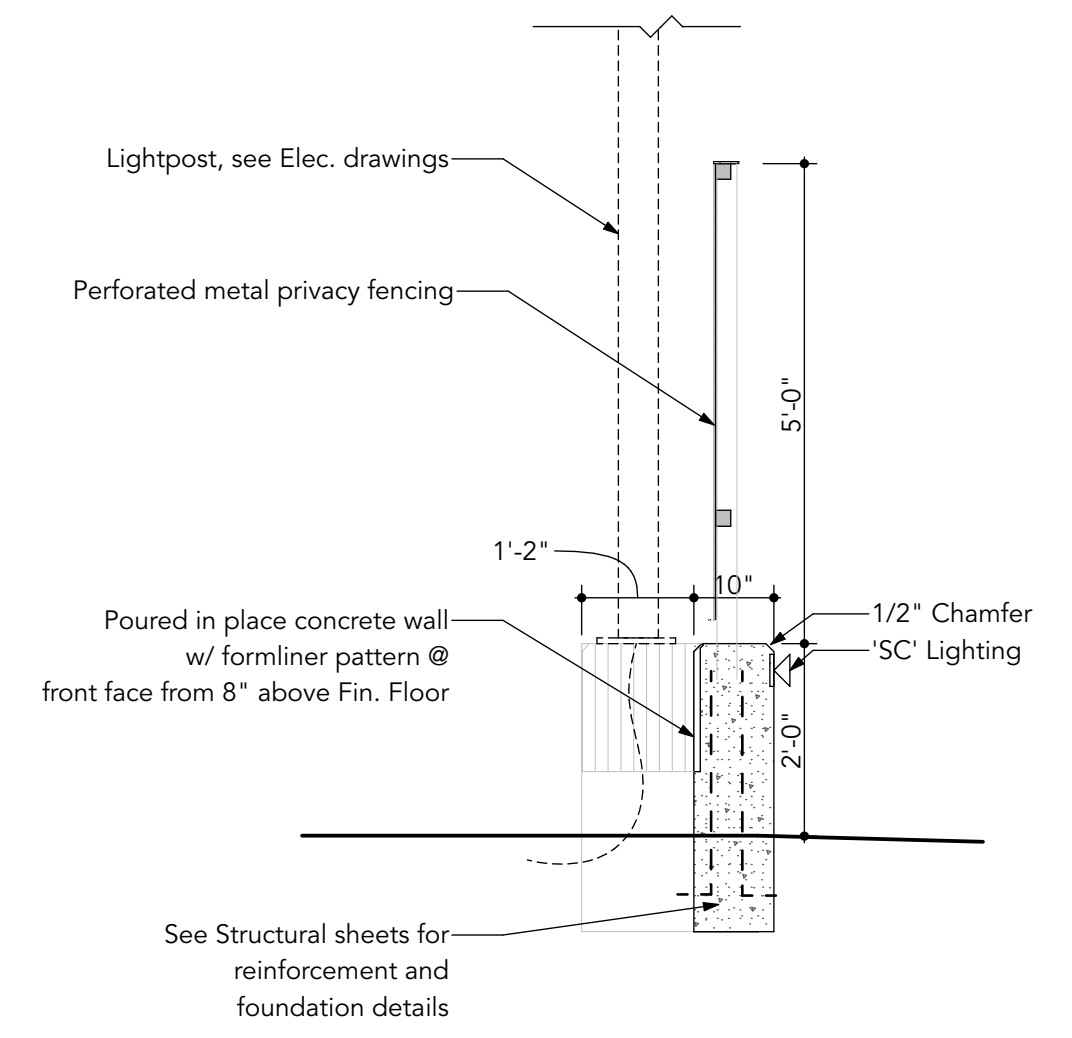
- Contact "MISS DIG" at phone number 811 three (3) days prior to the start of construction, excluding Saturdays, Sundays, and holidays.
- No dimension may be scaled, refer unclear items to the architect for interpretation.
- Refer to Mechanical, Electrical, Plumbing, Structural & Civil drawings for additional site scope.
- Upon request, electronic information will be provided for site layout purposes. Contractor shall request all information in writing through intersect studio. Layout of all new construction shall be done by a licensed surveyor.
- Contractor to restore and repair any existing conditions disturbed by construction to an equal or better condition than before construction began, including buried utilities, lighting, landscaping, irrigation, etc.
- Concrete flatwork shall not pool water. Slope all pavement for proper drainage of 2% minimum, but do not exceed maximum slope as required by ADA along the accessible route, and at all accessible doors.
- All pavement, curb & gutter, sidewalk, and utilities within public right of way shall meet City of Kalamazoo standards.
- Landscaping for reference only. See Civil drawings for additional information.
- Existing irrigation system and layout to be modified as required for new sitework. Verify existing conditions and areas that will be impacted. Provide submittal showing heads and piping to be relocated where necessary, or to be added new. Provide irrigation at new landscape beds and lawn areas.

Site Plan Key

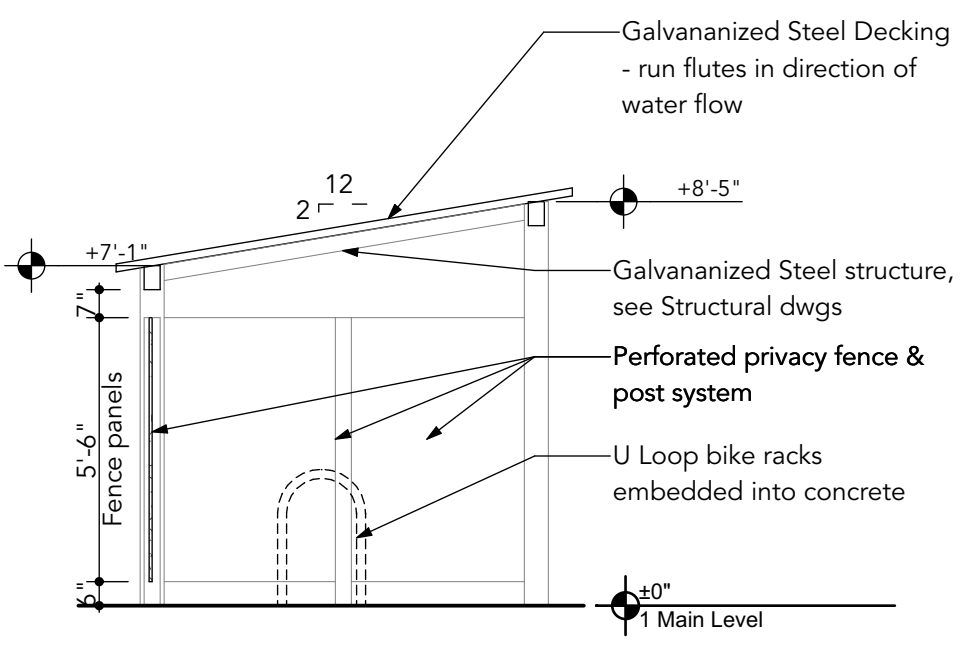
	New Pavement
	New Asphalt & Striping
	New Landscaping Beds
	New Parking Islands and Curb
	Provide 4" dia. Schedule 40 PVC sleeve for irrigation under new hardscape



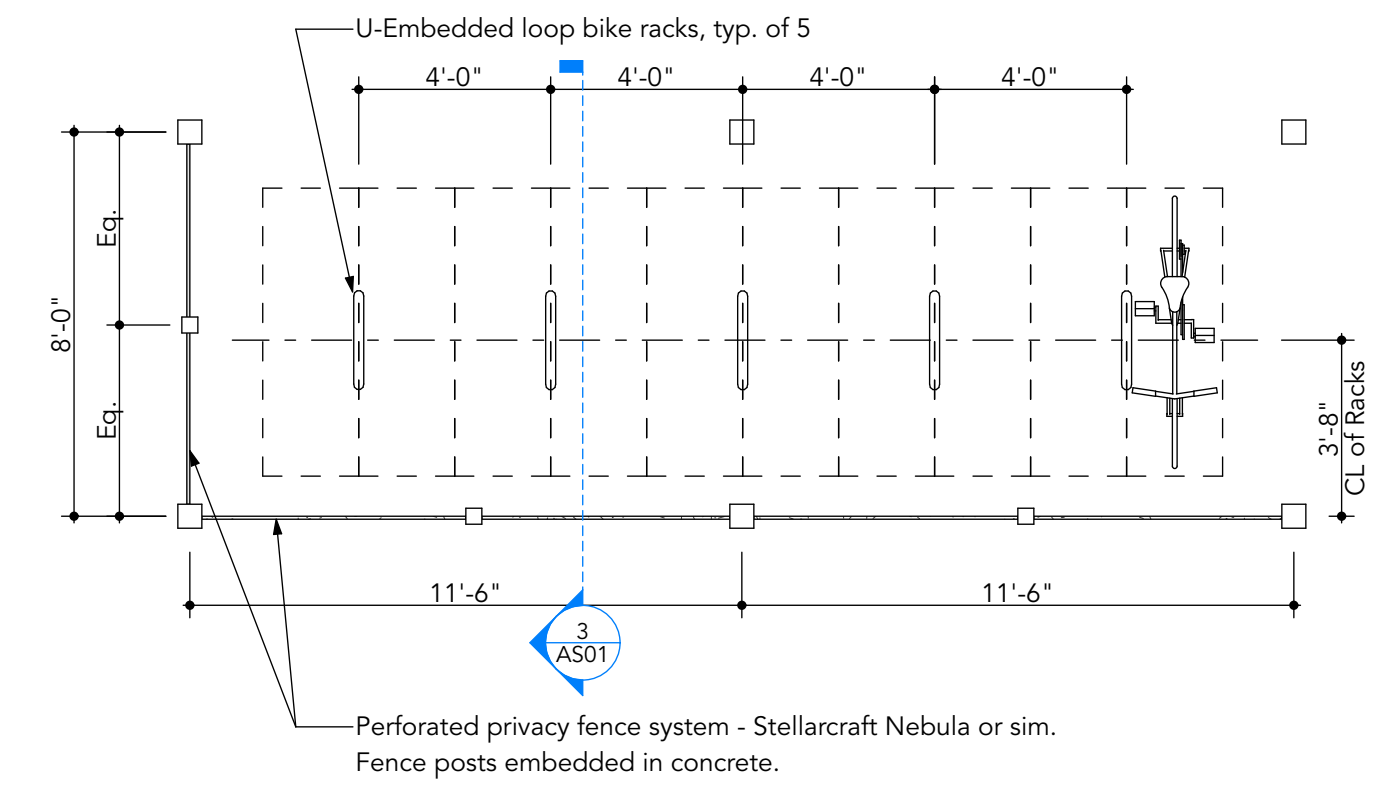
5 Site Wall Plan Detail
AS01 SCALE: 1/2" = 1'-0"



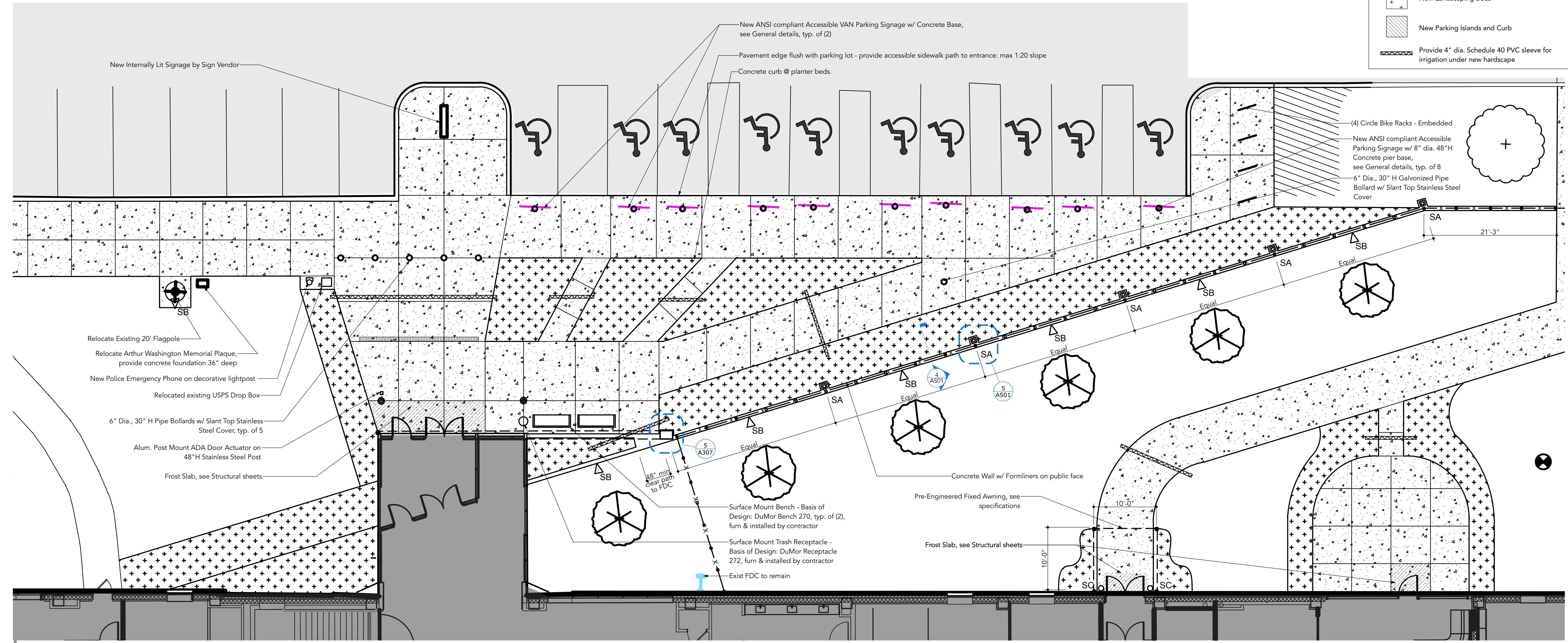
4 Site Wall Section
AS01 SCALE: 1/2" = 1'-0"



3 Bike Shelter Section
AS01 SCALE: 1/4" = 1'-0"



2 Bike Shelter Enlarged Plan
AS01 SCALE: 1/4" = 1'-0"



1 Enlarged Site Plan
AS01 SCALE: 1/8" = 1'-0"

NOT FOR
 REGULATORY
 APPROVAL,
 PERMITTING, OR
 CONSTRUCTION

Bid Set 08/21/2025
 Site Plan Review 07/31/2025
 DD Set 07/03/2025
 © 2025, intersect studio, llc
 Project Number: 23-046

Demolition Plan -
 Main Level CPED

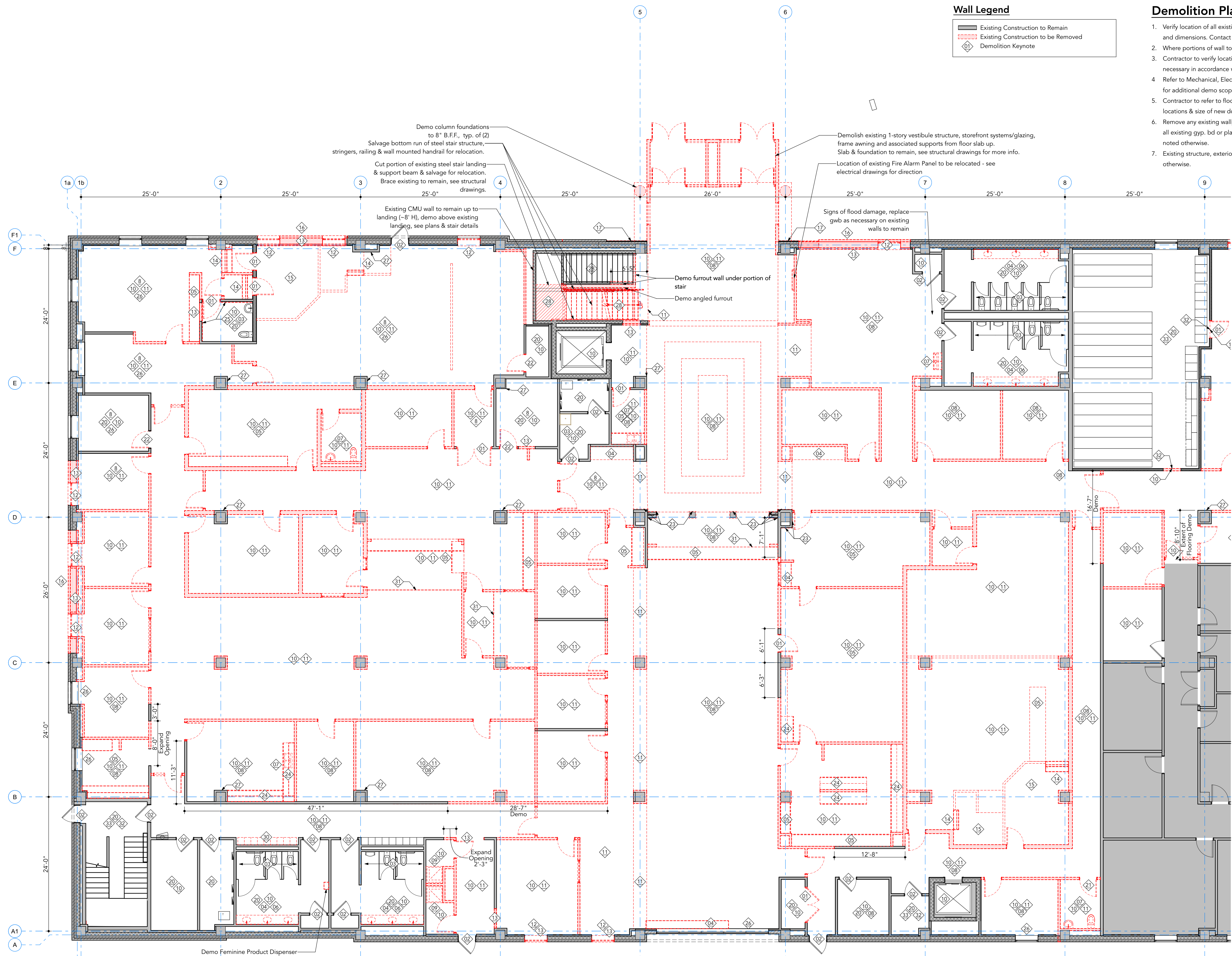
A001

Wall Legend

- Existing Construction to Remain
- Existing Construction to be Removed
- Demolition Keynote

- ### Demolition Plan Notes
1. Verify location of all existing structural elements, existing wall systems, and dimensions. Contact architect with any discrepancies.
 2. Where portions of wall to be removed, brace structure as needed.
 3. Contractor to verify locations where existing exterior finish removal is necessary in accordance with new work.
 4. Refer to Mechanical, Electrical, Plumbing, Structural & Civil drawings for additional demo scope.
 5. Contractor to refer to floor plans and door and window schedule for locations & size of new door and window openings.
 6. Remove any existing wallpaper, wall base, or other non-paint finish on all existing gyp. bd or plaster walls or column wraps to remain, unless noted otherwise.
 7. Existing structure, exterior envelope & glazing to remain unless noted otherwise.

- ### Demolition Plan Keynotes
- 01 Remove existing door, frame, and frame anchors.
 - 02 Existing door & frame to remain. See door schedule for hardware notes.
 - 03 Existing plumbing fixtures and grab bars to remain.
 - 04 Remove countertops & any sinks. Maintain & temporarily cap plumbing for new fixtures.
 - 05 Remove casework.
 - 06 Ceramic wall tile wainscot and toilet partitions to remain. See enlarged TR plans for more info on accessories. Demo mirrors and vanity lighting for replacement. Demo wallpaper where existing.
 - 07 Remove plumbing fixtures. See Plumbing dwgs.
 - 08 Remove wall trim, wallpaper, or other non-paint wall finishes back to sheathing/gyp. bd.
 - 09 Remove shower, accessories, and tile surround back to sheathing on existing walls to remain. See plumbing sheets.
 - 10 Remove exist. flooring back to concrete or terrazzo slab and associated wall base or cove base.
 - 11 Remove exist. ceiling, lighting, bulkheads, and diffusers, U.N.O. Salvage clean 2x2 standard tegular tiles to reuse/replace elsewhere in building.
 - 12 Remove exist. window & frame. See window schedule for new opening dimensions.
 - 13 Cut into exist. wall material to create new opening. Intent at exterior masonry walls is for opening to align with nearest existing grout lines. Brace as necessary until new structure is in place (see structural dwgs). See floor plans, window sched. and door sched. for new opening type and size.
 - 14 Remove exist. stair and associated handrail(s).
 - 15 Remove existing raised floors and associated elements and casework.
 - 16 Salvage outer exist. brick layer to be removed for reuse.
 - 17 Remove outer exist. EIFS layer & clean brick.
 - 18 Remove exterior shaft & structure back to exterior brick.
 - 19 Ceramic wall tile wainscot to remain. See enlarged TR plans for more info on accessories. Demo vanity lighting for replacement. Demo wallpaper.
 - 20 Remove existing lighting. Existing ceiling and grid to remain.
 - 21 Remove existing door, frame, and frame anchors & salvage for reuse.
 - 22 Remove existing door only, existing frame to remain.
 - 23 Remove existing wall finishes and sheathing back to studs for future bullet resistant construction.
 - 24 Casework to be salvaged & stored for reuse. Salvage standard double door/single door base cabinets and wall cabinets, and all cabinets with finished end panels. Demo countertops, typ. Any tag #XXX.X shown is associated with new room number for relocation. See Floor Plans & Elevations for more info.
 - 25 Demo tile wainscot on north & west walls only. Demo vanity lighting for replacement. Remove wallpaper throughout.
 - 26 Windows & sills to remain. Demo blinds.
 - 27 Demo existing wall up to 8'-11" AFF, leave framing for bulkhead at existing ceiling above.
 - 28 Remove terrazzo back to stair landing/structure.
 - 29 Removal of existing door and/or frame may be necessary - coordinate with Owner's Access Control vendor.
 - 30 Demolish metal lockers & stud/gyp header up to 7'-0" AFF.
 - 31 Demolish existing overhead coiling grille or operable partition.
 - 32 Existing flooring to remain.
 - 33 Existing wall finishes and/or wall protection to remain.
 - 34 Existing ceiling & lighting to remain.
 - 35 Existing casework & countertops to remain.
 - 36 Salvage existing door and frame for swing change re-installation in same location.



1
A001 Demolition Main Level Plan
 SCALE: 1/8" = 1'-0"

CPED
 N.I.C.

Key Plan - CPED

8/25/25 - BIMModel: Intersect AC27 Network Server - BIMModel: Intersect AC27 Network Server - BIMModel: Intersect AC27 Network Server - BIMModel: Intersect AC27 Network Server

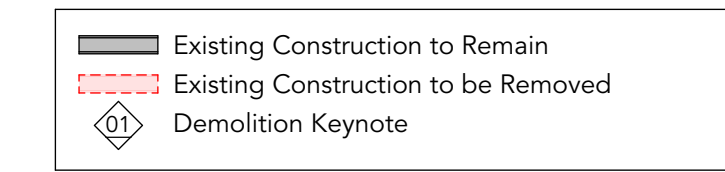
NOT FOR
 REGULATORY
 APPROVAL,
 PERMITTING, OR
 CONSTRUCTION

Bid Set 08/21/2025
 Site Plan Review 07/31/2025
 DD Set 07/03/2025
 © 2025, intersect studio, llc
 Project Number: 23-046

Demolition Plan -
 Main Level KDPS

A002

Wall Legend

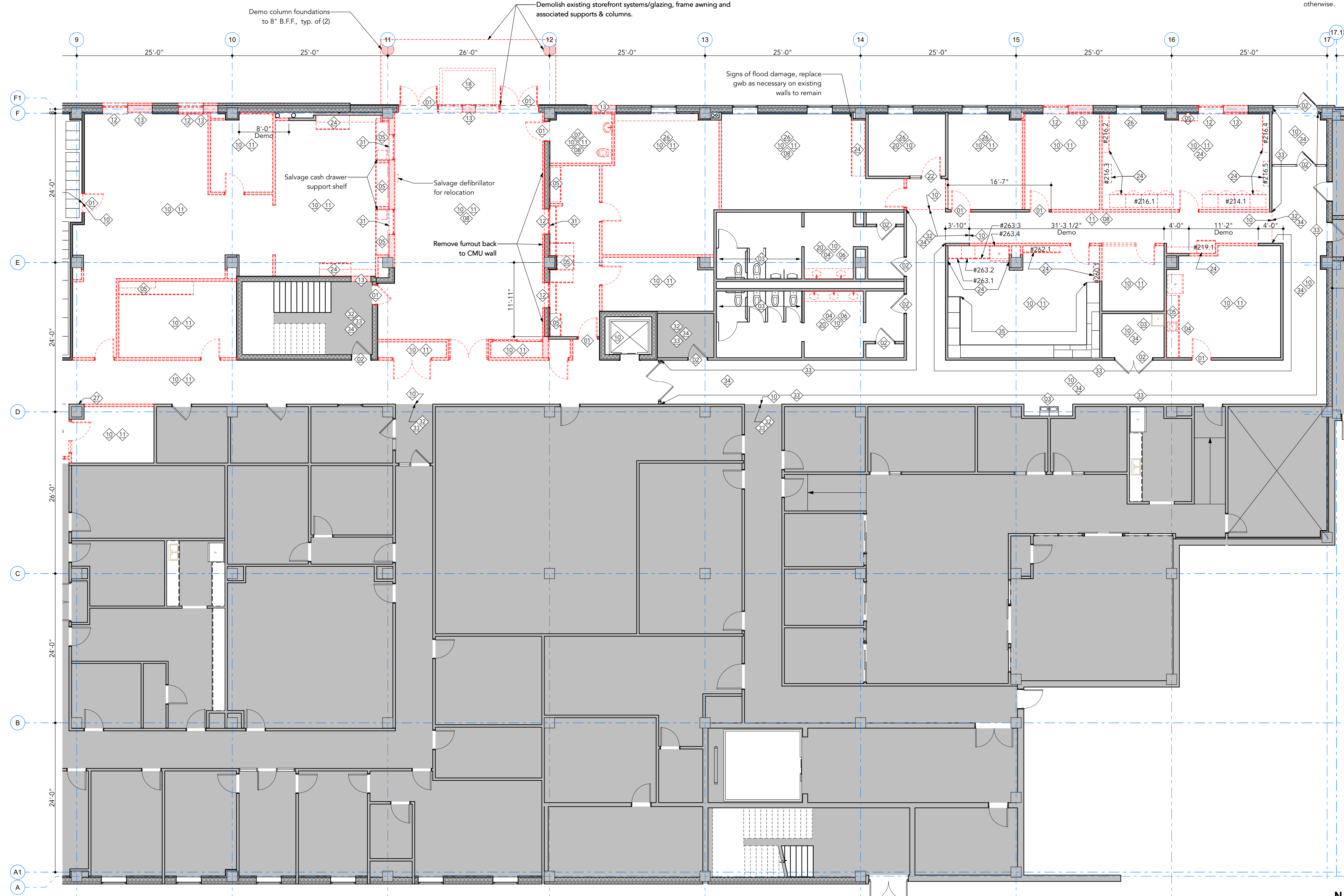


Demolition Plan Notes

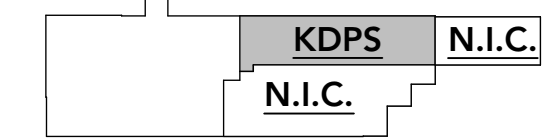
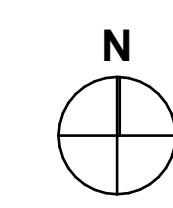
1. Verify location of all existing structural elements, existing wall systems, and dimensions. Contact architect with any discrepancies.
2. Where portions of wall to be removed, brace structure as needed.
3. Contractor to verify locations where existing exterior finish removal is necessary in accordance with new work.
4. Refer to Mechanical, Electrical, Plumbing, Structural & Civil drawings for additional demo scope.
5. Contractor to refer to floor plans and door and window schedule for locations & size of new door and window openings.
6. Remove any existing wallpaper, wall base, or other non-paint finish on all existing gyp. bd or plaster walls or column wraps to remain, unless noted otherwise.
7. Existing structure, exterior envelope & glazing to remain unless noted otherwise.

Demolition Plan Keynotes

- 01 Remove existing door, frame, and frame anchors.
- 02 Existing door & frame to remain. See door schedule for hardware notes.
- 03 Existing plumbing fixtures and grab bars to remain.
- 04 Remove countertops & any sinks. Maintain & temporarily cap plumbing for new fixtures.
- 05 Remove casework.
- 06 Ceramic wall tile wainscot and toilet partitions to remain. See enlarged TR plans for more info on accessories. Demo mirrors and vanity lighting for replacement. Demo wallpaper where existing.
- 07 Remove plumbing fixtures. See Plumbing dwgs.
- 08 Remove wall trim, wallpaper, or other non-paint wall finishes back to sheathing/gyp. bd.
- 09 Remove shower, accessories, and tile surround back to sheathing on existing walls to remain. See plumbing sheets.
- 10 Remove exist. flooring back to concrete or terrazzo slab and associated wall base or cove base.
- 11 Remove exist. ceiling, lighting, bulkheads, and diffusers, U.N.O. Salvage clean 2x2 standard tegular tiles to reuse/replace elsewhere in building.
- 12 Remove exist. window & frame. See window schedule for new opening dimensions.
- 13 Cut into exist. wall material to create new opening. Intent at exterior masonry walls is for opening to align with nearest existing grout lines. Brace as necessary until new structure is in place (see structural dwgs). See floor plans, window sched. and door sched. for new opening type and size.
- 14 Remove exist. stair and associated handrail(s).
- 15 Remove existing raised floors and associated elements and casework.
- 16 Salvage outer exist. brick layer to be removed for reuse.
- 17 Remove outer exist. EIFS layer & clean brick.
- 18 Remove exterior shaft & structure back to exterior brick.
- 19 Ceramic wall tile wainscot to remain. See enlarged TR plans for more info on accessories. Demo vanity lighting for replacement. Demo wallpaper.
- 20 Remove existing lighting. Existing ceiling and grid to remain.
- 21 Remove existing door, frame, and frame anchors & salvage for reuse.
- 22 Remove existing door only, existing frame to remain.
- 23 Remove existing wall finishes and sheathing back to studs for future bullet resistant construction.
- 24 Casework to be salvaged & stored for reuse. Salvage standard double door/single door base cabinets and wall cabinets, and all cabinets with finished end panels. Demo countertops, typ. Any tag #XXX.X shown is associated with new room number for relocation. See Floor Plans & Elevations for more info.
- 25 Demo tile wainscot on north & west walls only. Demo vanity lighting for replacement. Remove wallpaper throughout.
- 26 Windows & sills to remain. Demo blinds.
- 27 Demo existing wall up to 8'-11" AFF, leave framing for bulkhead at existing ceiling above.
- 28 Remove terrazzo back to stair landing/structure.
- 29 Removal of existing door and/or frame may be necessary - coordinate with Owner's Access Control vendor.
- 30 Demolish metal lockers & stud/gyp header up to 7'-0" AFF.
- 31 Demolish existing overhead coiling grille or operable partition.
- 32 Existing flooring to remain.
- 33 Existing wall finishes and/or wall protection to remain.
- 34 Existing ceiling & lighting to remain.
- 35 Existing casework & countertops to remain.
- 36 Salvage existing door and frame for swing change re-installation in same location.



1 Demolition Main Level Plan
 SCALE: 1/8" = 1'-0"



Key Plan - KDPS

8/25/25 - BIMcloud - Intersect AC27 Network Server - BIMcloud Bluest for Archival 27/25/25 Koro Crosstown Facility

Wall Legend

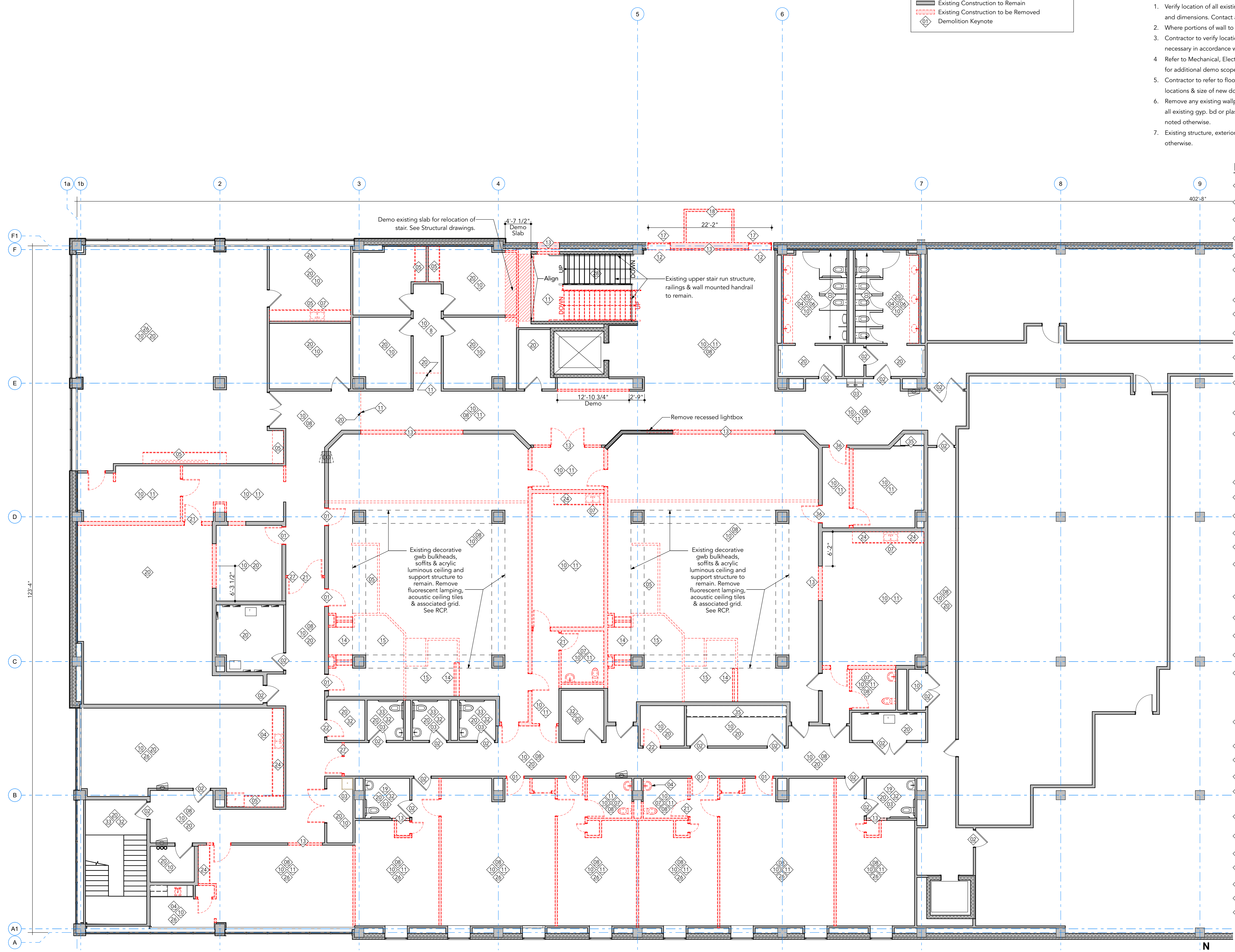
- Existing Construction to Remain
- Existing Construction to be Removed
- 01 Demolition Keynote

Demolition Plan Notes

1. Verify location of all existing structural elements, existing wall systems, and dimensions. Contact architect with any discrepancies.
2. Where portions of wall to be removed, brace structure as needed.
3. Contractor to verify locations where existing exterior finish removal is necessary in accordance with new work.
4. Refer to Mechanical, Electrical, Plumbing, Structural & Civil drawings for additional demo scope.
5. Contractor to refer to floor plans and door and window schedule for locations & size of new door and window openings.
6. Remove any existing wallpaper, wall base, or other non-paint finish on all existing gyp. bd or plaster walls or column wraps to remain, unless noted otherwise.
7. Existing structure, exterior envelope & glazing to remain unless noted otherwise.

Demolition Plan Keynotes

- 01 Remove existing door, frame, and frame anchors.
- 02 Existing door & frame to remain. See door schedule for hardware notes.
- 03 Existing plumbing fixtures and grab bars to remain.
- 04 Remove countertops & any sinks. Maintain & temporarily cap plumbing for new fixtures.
- 05 Remove casework.
- 06 Ceramic wall tile wainscot and toilet partitions to remain. See enlarged TR plans for more info on accessories. Demo mirrors and vanity lighting for replacement. Demo wallpaper where existing.
- 07 Remove plumbing fixtures. See Plumbing dwgs.
- 08 Remove wall trim, wallpaper, or other non-paint wall finishes back to sheathing/gyp. bd.
- 09 Remove shower, accessories, and tile surround back to sheathing on existing walls to remain. See plumbing sheets.
- 10 Remove exist. flooring back to concrete or terrazzo slab and associated wall base or cove base.
- 11 Remove exist. ceiling, lighting, bulkheads, and diffusers, U.N.O. Salvage clean 2x2 standard tegular tiles to reuse/replace elsewhere in building.
- 12 Remove exist. window & frame. See window schedule for new opening dimensions.
- 13 Cut into exist. wall material to create new opening. Intent at exterior masonry walls is for opening to align with nearest existing grout lines. Brace as necessary until new structure is in place (see structural dwgs). See floor plans, window sched. and door sched. for new opening type and size.
- 14 Remove exist. stair and associated handrail(s).
- 15 Remove existing raised floors and associated elements and casework.
- 16 Salvage outer exist. brick layer to be removed for reuse.
- 17 Remove outer exist. EIFS layer & clean brick.
- 18 Remove exterior shaft & structure back to exterior brick.
- 19 Ceramic wall tile wainscot to remain. See enlarged TR plans for more info on accessories. Demo vanity lighting for replacement. Demo wallpaper.
- 20 Remove existing lighting. Existing ceiling and grid to remain.
- 21 Remove existing door, frame, and frame anchors & salvage for reuse.
- 22 Remove existing door only, existing frame to remain.
- 23 Remove existing wall finishes and sheathing back to studs for future bullet resistant construction.
- 24 Casework to be salvaged & stored for reuse. Salvage standard double door/single door base cabinets and wall cabinets, and all cabinets with finished end panels. Demo countertops, typ. Any tag #XXX.X shown is associated with new room number for relocation. See Floor Plans & Elevations for more info.
- 25 Demo tile wainscot on north & west walls only. Demo vanity lighting for replacement. Remove wallpaper throughout.
- 26 Windows & sills to remain. Demo blinds.
- 27 Demo existing wall up to 8'-11" AFF, leave framing for bulkhead at existing ceiling above.
- 28 Remove terrazzo back to stair landing/structure.
- 29 Removal of existing door and/or frame may be necessary - coordinate with Owner's Access Control vendor.
- 30 Demolish metal lockers & stud/gyp header up to 7'-0" AFF.
- 31 Demolish existing overhead ceiling grille or operable partition.
- 32 Existing flooring to remain.
- 33 Existing wall finishes and/or wall protection to remain.
- 34 Existing ceiling & lighting to remain.
- 35 Existing casework & countertops to remain.
- 36 Salvage existing door and frame for swing change re-installation in same location.



1 Demolition Upper Level Plan
 A003 SCALE: 1/8" = 1'-0"

CPED N.I.C. N.I.C.

Key Plan - CPED

9/25/25 - BIMcloud: Intersect AC27 Network Server - BIMcloud Basic for Archival 27/25/25 Koro Crosstown Facility

NOT FOR
 REGULATORY
 APPROVAL,
 PERMITTING, OR
 CONSTRUCTION

Bid Set 08/21/2025
 Site Plan Review 07/31/2025
 DD Set 07/03/2025
 © 2025, Intersect studio, llc
 Project Number: 23-046

Main Level Plan
 CPED

A100

Wall Legend

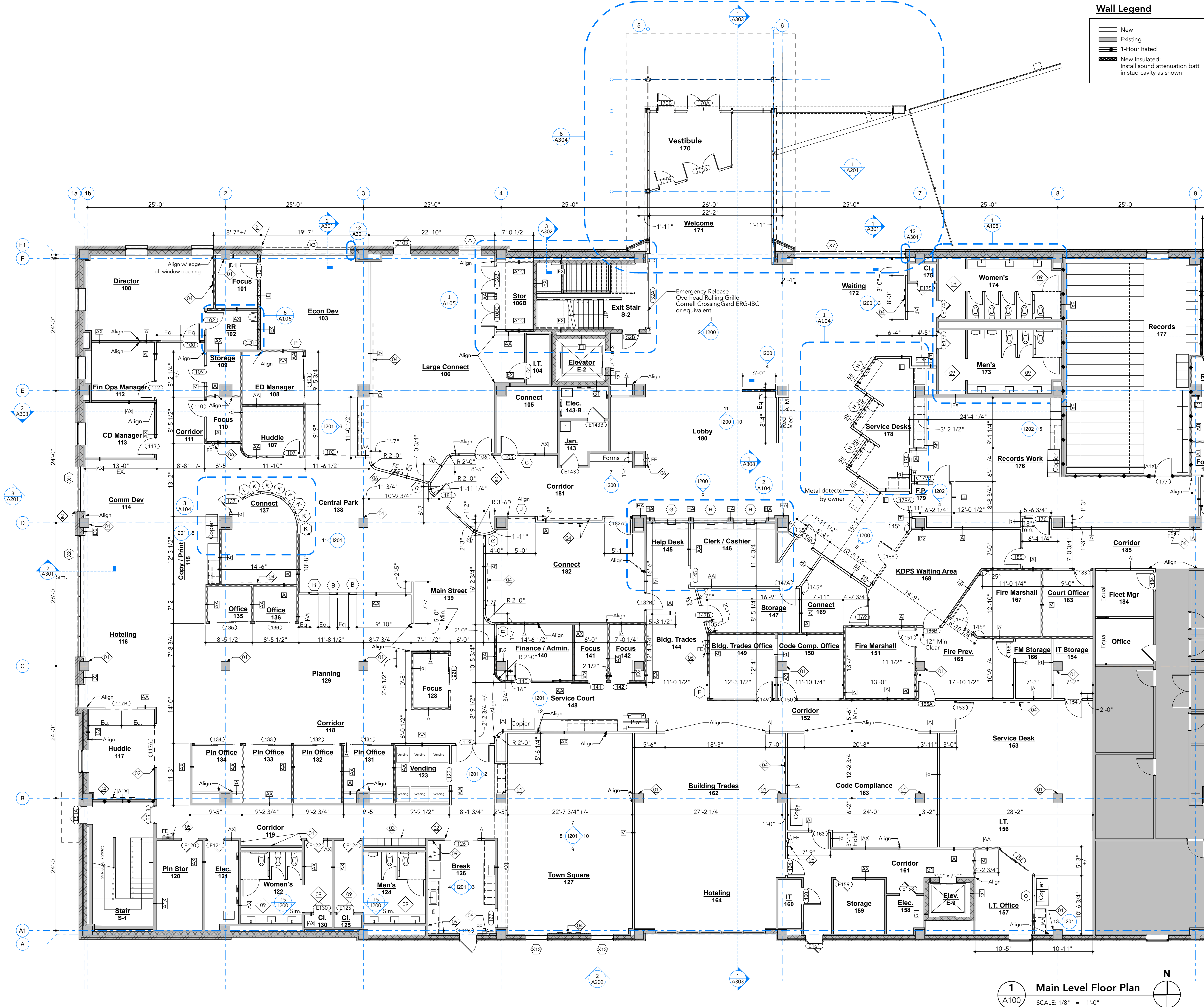
- New
- Existing
- 1-Hour Rated
- New Insulated:
Install sound attenuation batt
in stud cavity as shown

Floor Plan Notes

1. Verify location of all existing structural elements, existing wall systems, and dimensions. Report to architect any discrepancies or omissions which would interfere with satisfactory completion of the work per the plans.
2. See Mechanical, Electrical, Plumbing, Structural, Civil & Technology drawings for additional scope & information.
3. See A400 sheets for door and window schedules.
4. See Interiors sheets for finish schedules and additional information regarding design intent.
5. Wall dimensions are to face of masonry, face of concrete, face of gyp. bd., column centerline as shown or existing construction, unless noted otherwise.
6. Provide FRT blocking in walls or ceilings as required for mounting cabinetry, shelving, fixtures, monitors, grab bars, lighting, owner provided equipment, etc. Provide 3/4" FRT plywood in larger zones as needed.
7. Where previous finishes have been removed and surfaces are existing to remain, prepare slabs and walls for new finishes.
8. Patch & repair any damage to existing column wraps or existing walls to remain after demo & prep for new finish.
9. Ensure equipment to remain (including plumbing fixtures, casework, and equipment) is in good working order. Contact owner/architect if items are determined to be in unacceptable condition and should be replaced.
9. Kitchen appliances to be provided by owner and installed by contractor.
11. Provide expansion joints or control joints per manufacturer's recommendations and/or where new finishes meet existing.
12. See Wall Type Assembly details on sheet A103. A partition with suffix 'X' is existing.
13. There are many existing rated wall assemblies where ratings do not need to be maintained - see Egress Plan for rated wall locations which must remain intact in area of work.

Floor Plan Keynotes

- Ⓛ1 Expose existing concrete columns. Clean, remove any fasteners, and patch holes. Provide an ACI 301 Grout-Cleaned (Sack-Rubbed) Finish to match existing.
- Ⓛ2 Edge of new opening to align with edge of existing opening.
- Ⓛ3 Existing metal lockers to remain. Clean and repair as needed.
- Ⓛ4 Provide blocking for TV monitors. See electrical drawings for all locations. Coordinate with owner's AV vendor for exact monitor size and placement.
- Ⓛ5 Existing semi-recessed fire extinguisher cabinets to remain. Ensure code compliant & in good working order.
- Ⓛ6 New fire extinguisher cabinet.
- Ⓛ7 Provide blocking for mirrors. See typ. elevation.
- Ⓛ8 Provide blocking for TV monitors above 7'-0" AFF. Coordinate with owner's AV vendor for exact monitor size and placement.
- Ⓛ9 Skim existing textured wall finish to provide new Level 4 smooth paintable surface.
- Ⓛ10 Finish wall w/ gyp. & prep for new finish



1 Main Level Floor Plan
 SCALE: 1/8" = 1'-0"

CPED N.I.C. N.I.C.

Key Plan - CPED

9/8/25 - BIMcloud - Intersect AC27 Framework Server - BIMcloud Basis for Archival 27/23/24 Koro Crosstown Facility

NOT FOR
 REGULATORY
 APPROVAL,
 PERMITTING, OR
 CONSTRUCTION

Bid Set 08/21/2025
 Site Plan Review 07/31/2025
 DD Set 07/03/2025
 © 2025, Intersect studio, llc
 Project Number: 23-046

Main Level Floor
 Plan KDPS

A101

Wall Legend

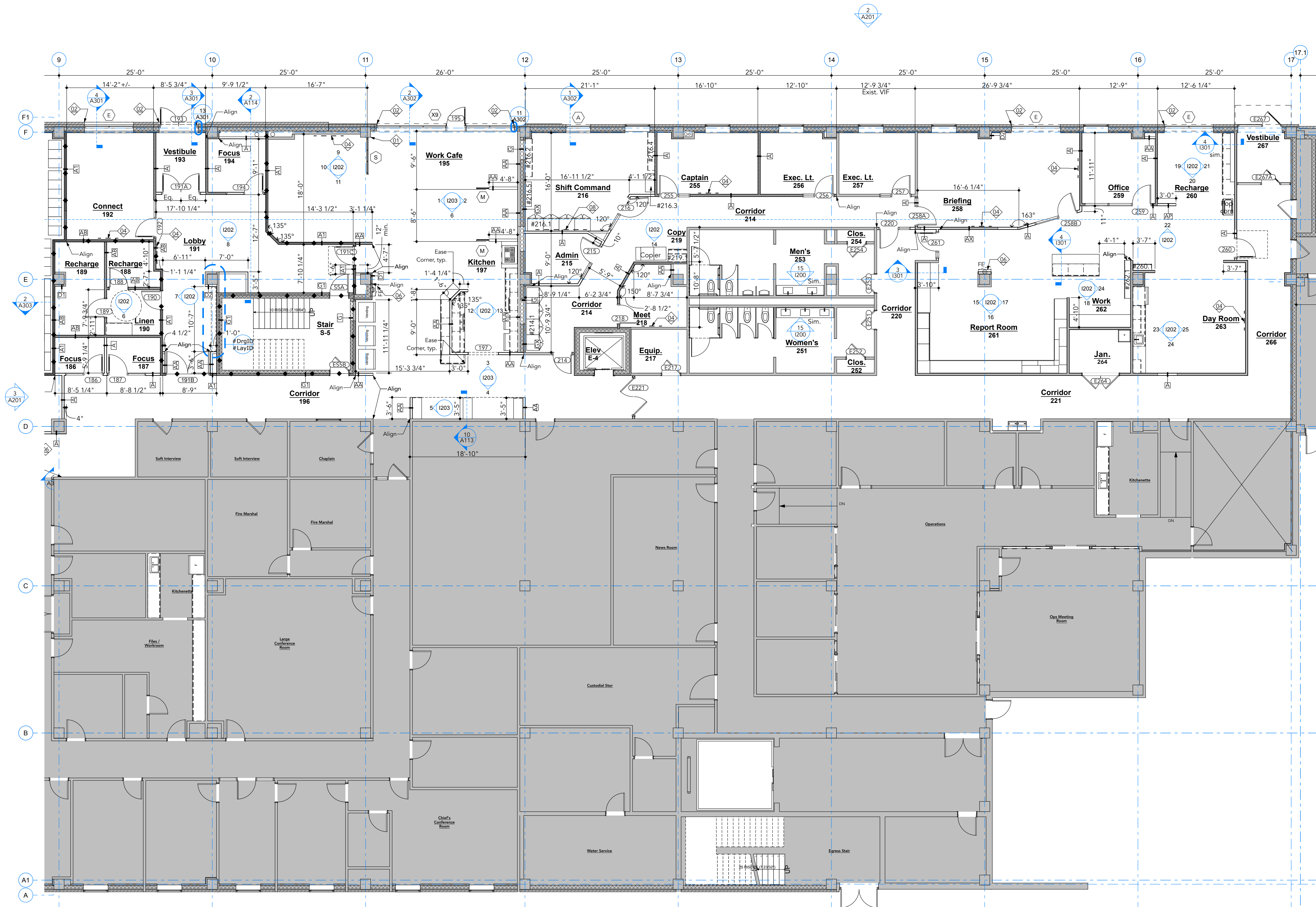
- New
- Existing
- 1-Hour Rated
- New Insulated:
Install sound attenuation batt
in stud cavity as shown

Floor Plan Notes

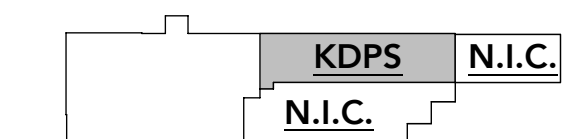
1. Verify location of all existing structural elements, existing wall systems, and dimensions. Report to architect any discrepancies or omissions which would interfere with satisfactory completion of the work per the plans.
2. See Mechanical, Electrical, Plumbing, Structural, Civil & Technology drawings for additional scope & information.
3. See A400 sheets for door and window schedules.
4. See Interiors sheets for finish schedules and additional information regarding design intent.
5. Wall dimensions are to face of masonry, face of concrete, face of gyp. bd., column centerline as shown or existing construction, unless noted otherwise.
6. Provide FRT blocking in walls or ceilings as required for mounting cabinetry, shelving, fixtures, monitors, grab bars, lighting, owner provided equipment, etc. Provide 3/4" FRT plywood in larger zones as needed.
7. Where previous finishes have been removed and surfaces are existing to remain, prepare slabs and walls for new finishes.
8. Patch & repair any damage to existing column wraps or existing walls to remain after demo & prep for new finish.
9. Ensure equipment to remain (including plumbing fixtures, casework, and equipment) is in good working order. Contact owner/architect if items are determined to be in unacceptable condition and should be replaced.
9. Kitchen appliances to be provided by owner and installed by contractor.
11. Provide expansion joints or control joints per manufacturer's recommendations and/or where new finishes meet existing.
12. See Wall Type Assembly details on sheet A103. A partition with suffix 'X' is existing.
13. There are many existing rated wall assemblies where ratings do not need to be maintained - see Egress Plan for rated wall locations which must remain intact in area of work.

Floor Plan Keynotes

- 01 Expose existing concrete columns. Clean, remove any fasteners, and patch holes. Provide an ACI 301 Grout-Cleaned (Sack-Rubbed) Finish to match existing.
- 02 Edge of new opening to align with edge of existing opening.
- 03 Existing metal lockers to remain. Clean and repair as needed.
- 04 Provide blocking for TV monitors. See electrical drawings for all locations. Coordinate with owner's AV vendor for exact monitor size and placement.
- 05 Existing semi-recessed fire extinguisher cabinets to remain. Ensure code compliant & in good working order.
- 06 New fire extinguisher cabinet.
- 07 Provide blocking for mirrors. See typ. elevation.
- 08 Provide blocking for TV monitors above 7'-0" AFF. Coordinate with owner's AV vendor for exact monitor size and placement.
- 09 Skim existing textured wall finish to provide new Level 4 smooth paintable surface.
- 10 Finish wall w/ gyp. & prep for new finish



1 Main Level Floor Plan
 A101 SCALE: 1/8" = 1'-0" N



Key Plan - KDPS

NOT FOR
 REGULATORY
 APPROVAL,
 PERMITTING, OR
 CONSTRUCTION

Bid Set 08/21/2025
 Site Plan Review 07/31/2025
 DD Set 07/03/2025
 © 2025, intersect studio, llc
 Project Number: 23-046

Upper Level Plan
 CPED

Wall Legend

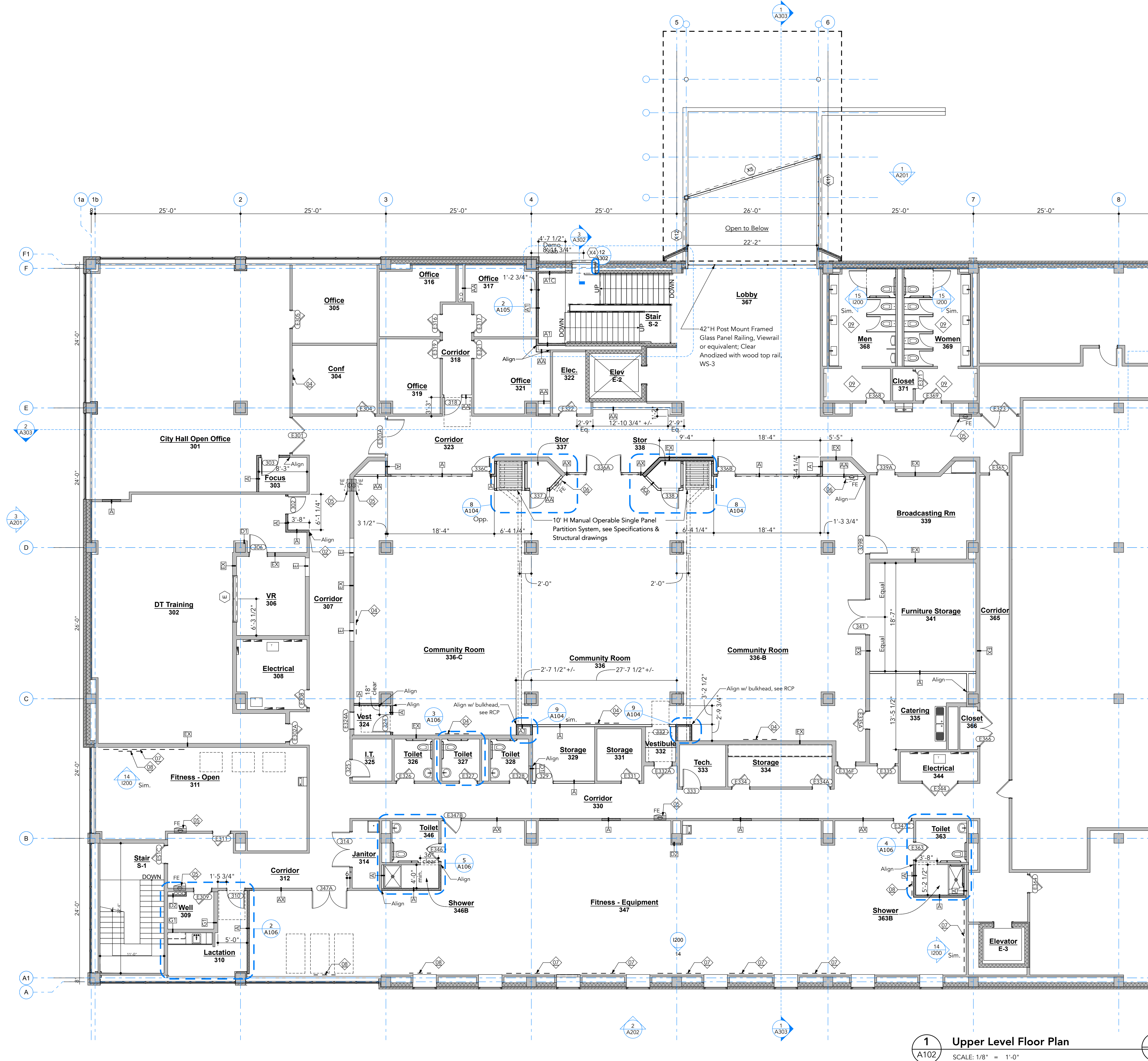
- New
- Existing
- 1-Hour Rated
- New Insulated:
Install sound attenuation batt
in stud cavity as shown

Floor Plan Notes

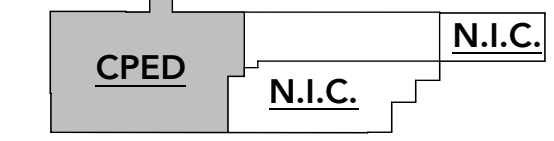
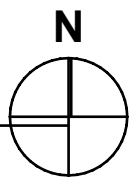
1. Verify location of all existing structural elements, existing wall systems, and dimensions. Report to architect any discrepancies or omissions which would interfere with satisfactory completion of the work per the plans.
2. See Mechanical, Electrical, Plumbing, Structural, Civil & Technology drawings for additional scope & information.
3. See A400 sheets for door and window schedules.
4. See Interiors sheets for finish schedules and additional information regarding design intent.
5. Wall dimensions are to face of masonry, face of concrete, face of gyp. bd., column centerline as shown or existing construction, unless noted otherwise.
6. Provide FRT blocking in walls or ceilings as required for mounting cabinetry, shelving, fixtures, monitors, grab bars, lighting, owner provided equipment, etc. Provide 3/4" FRT plywood in larger zones as needed.
7. Where previous finishes have been removed and surfaces are existing to remain, prepare slabs and walls for new finishes.
8. Patch & repair any damage to existing column wraps or existing walls to remain after demo & prep for new finish.
9. Ensure equipment to remain (including plumbing fixtures, casework, and equipment) is in good working order. Contact owner/architect if items are determined to be in unacceptable condition and should be replaced.
9. Kitchen appliances to be provided by owner and installed by contractor.
11. Provide expansion joints or control joints per manufacturer's recommendations and/or where new finishes meet existing.
12. See Wall Type Assembly details on sheet A103. A partition with suffix 'X' is existing.
13. There are many existing rated wall assemblies where ratings do not need to be maintained - see Egress Plan for rated wall locations which must remain intact in area of work.

Floor Plan Keynotes

- Expose existing concrete columns. Clean, remove any fasteners, and patch holes. Provide an ACI 301 Grout-Cleaned (Sack-Rubbed) Finish to match existing.
- Edge of new opening to align with edge of existing opening.
- Existing metal lockers to remain. Clean and repair as needed.
- Provide blocking for TV monitors. See electrical drawings for all locations. Coordinate with owner's AV vendor for exact monitor size and placement.
- Existing semi-recessed fire extinguisher cabinets to remain. Ensure code compliant & in good working order.
- New fire extinguisher cabinet.
- Provide blocking for mirrors. See typ. elevation.
- Provide blocking for TV monitors above 7'-0" AFF. Coordinate with owner's AV vendor for exact monitor size and placement.
- Skim existing textured wall finish to provide new Level 4 smooth paintable surface.
- Finish wall w/ gyp. & prep for new finish



1 Upper Level Floor Plan
 A102 SCALE: 1/8" = 1'-0"

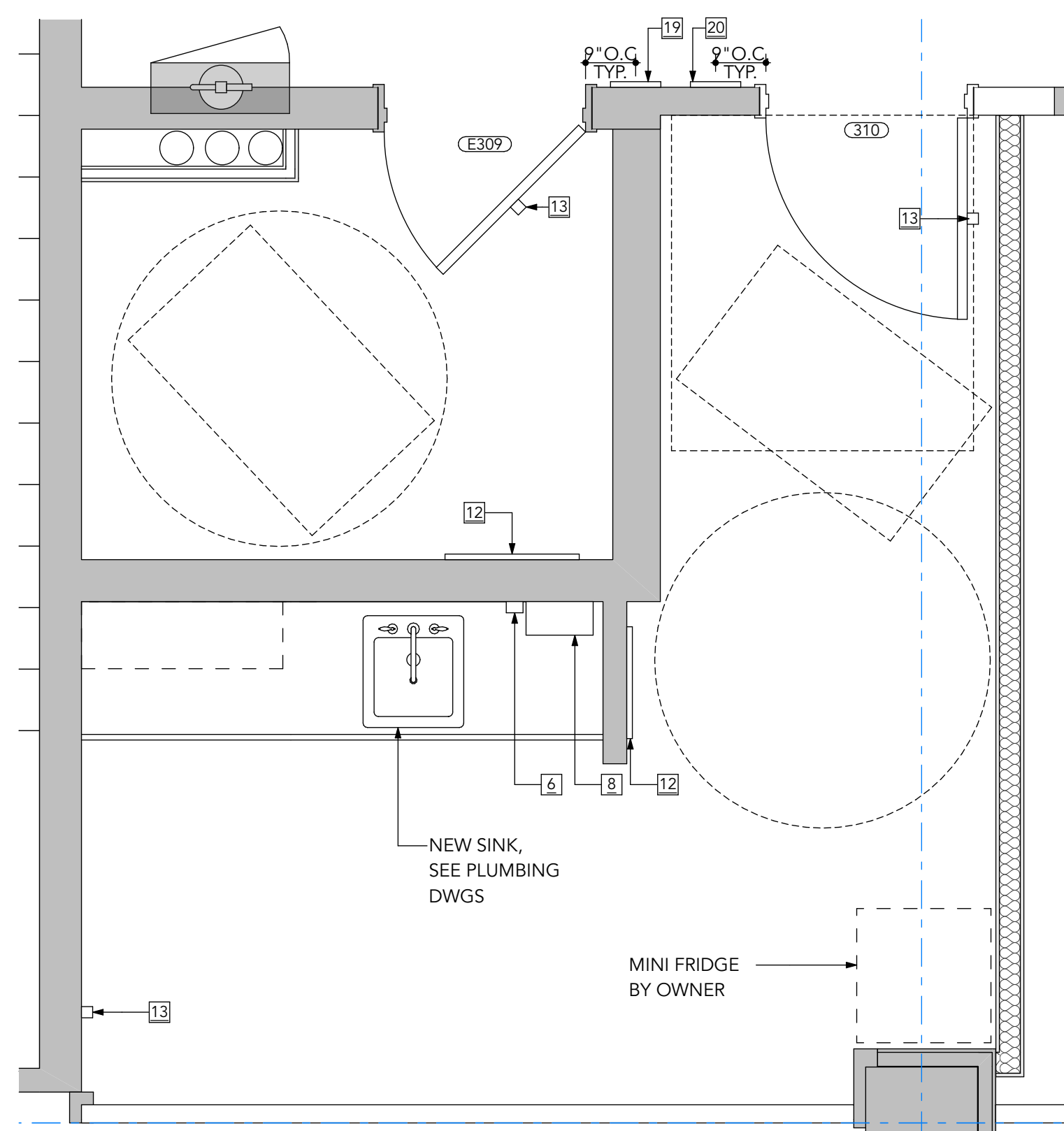


Key Plan - CPED

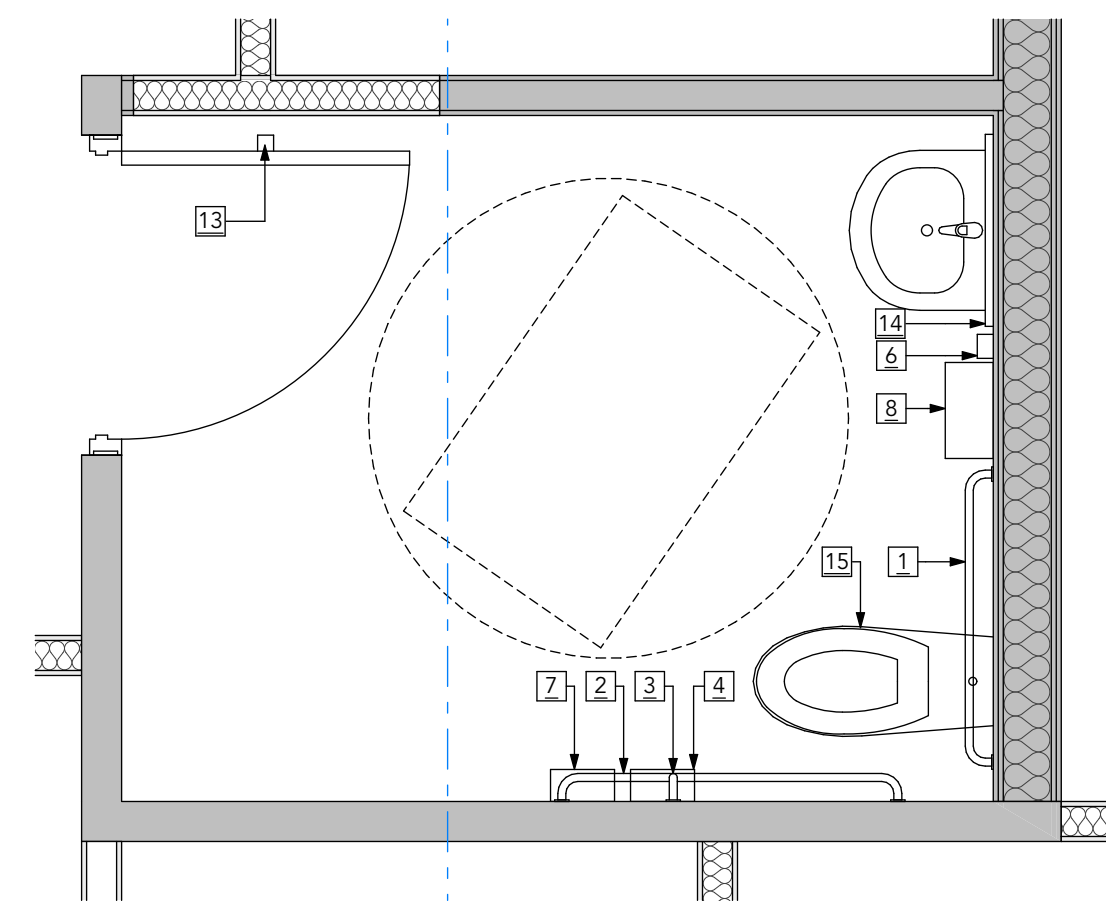
9/8/25 - BIMcloud: Intersect AC27 Framework Server - BIMcloud Basis for Archival 27/23/24 Koro Crosstown Facility

ACCESSORY SPECIFICATIONS		STYLE/MODEL		
TAG	ITEM	Manufacturer		FINISH
1	36" Grab Bar		Existing 36" Grab Bar to Remain	
2	42" Grab Bar		Existing 42" Grab Bar to Remain	
3	18" Grab Bar	Bobrick	Bobrick B-6806x18	Satin
4	Toilet paper holder		Existing to remain or New Provided by Owner's vendor	
5	Hand Dryer		Existing to remain, ensure in good working order	
6	Soap Dispenser		Existing to remain or New Provided by Owner's vendor	
7	Napkin Disposal	Bobrick	Bobrick B-270 Commercial Restroom Sanitary Napkin/Tampon Disposal	Satin
8	Roll Towel Dispenser		Existing to remain or New Provided by Owner's vendor	
9	ADA Toilet Room Signage- All Gender	Compliance Signs	White on Charcoal Gray California Title 24 Accessible All Gender Restroom Sign	Charcoal Gray with White Text
10	Mirror	American Specialties	ASI 0620-3636 Mirror, 36" x 36"	Satin
11	Mirror	American Specialties	ASI 0620-2436 Mirror, 24" x 36"	Satin
12	Mirror	American Specialties	ASI 0620-2060 Mirror, 20" x 60"	Satin
13	Coat Hook	Bobrick	Existing to remain or Bobrick B-6827 coat hook	Satin
14	Mirror		Existing to remain	
15	Open front toilet seat		Heavy Duty Commercial Open Front Toilet Seat. Compatible with existing toilets	White
16	Changing Station		Existing Changing Station to Remain	
17	ADA Toilet Room Signage- Women's	Compliance Signs	White on Charcoal Gray California Title 24 Accessible Women's Restroom Sign	Charcoal Gray with White Text
18	ADA Toilet Room Signage- Men's	Compliance Signs	White on Charcoal Gray California Title 24 Accessible Men's Restroom Sign	Charcoal Gray with White Text
19	ADA Room Signage- Wellness	Compliance Signs	White on Charcoal Gray California Title 24 Accessible Wellness Room Sign	Charcoal Gray with White Text
20	Lactation Room Signage	Compliance Signs	White on Charcoal Gray California Title 24 Lactation Room	Charcoal Gray with White Text
21	60" Shower Curtain Rod	Bobrick	Bobrick B-6107x60 Heavy-Duty Shower Curtain Rod, 60"	Satin
22	48" Shower Curtain Rod	Bobrick	Bobrick B-6107x48 Heavy-Duty Shower Curtain Rod, 48"	Satin
23	ADA Roll In Shower		See Plumbing DWGs	White
24	24" Grab Bar	Bobrick	Bobrick B-6806x24. New 24" Grab Bar	Satin
25	36" Grab Bar	Bobrick	Bobrick B-6806x36. New 36" Grab Bar	Satin
26	Baby Changing Station	ASI	ASI 9014 Surface Mounted Horizontal Baby Changing Station	Gray

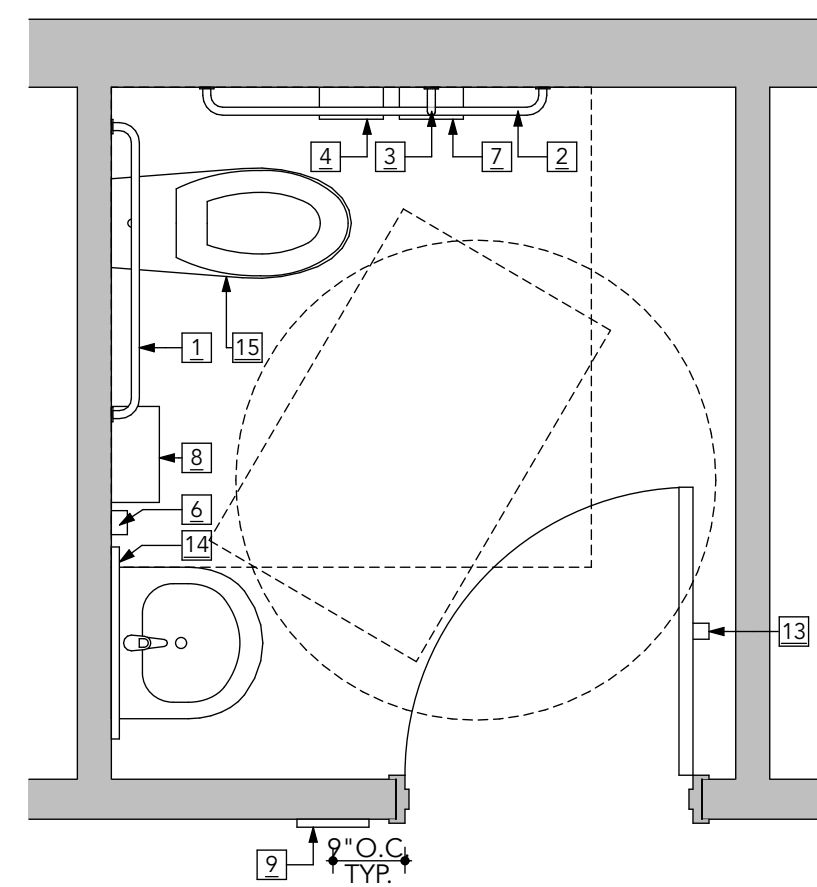
NOTE: All selections are basis of design



2 Well #309 & Lactation Room #310
A106 SCALE: 1/2" = 1'-0"



6 Toilet Room #102
A106 SCALE: 1/2" = 1'-0"



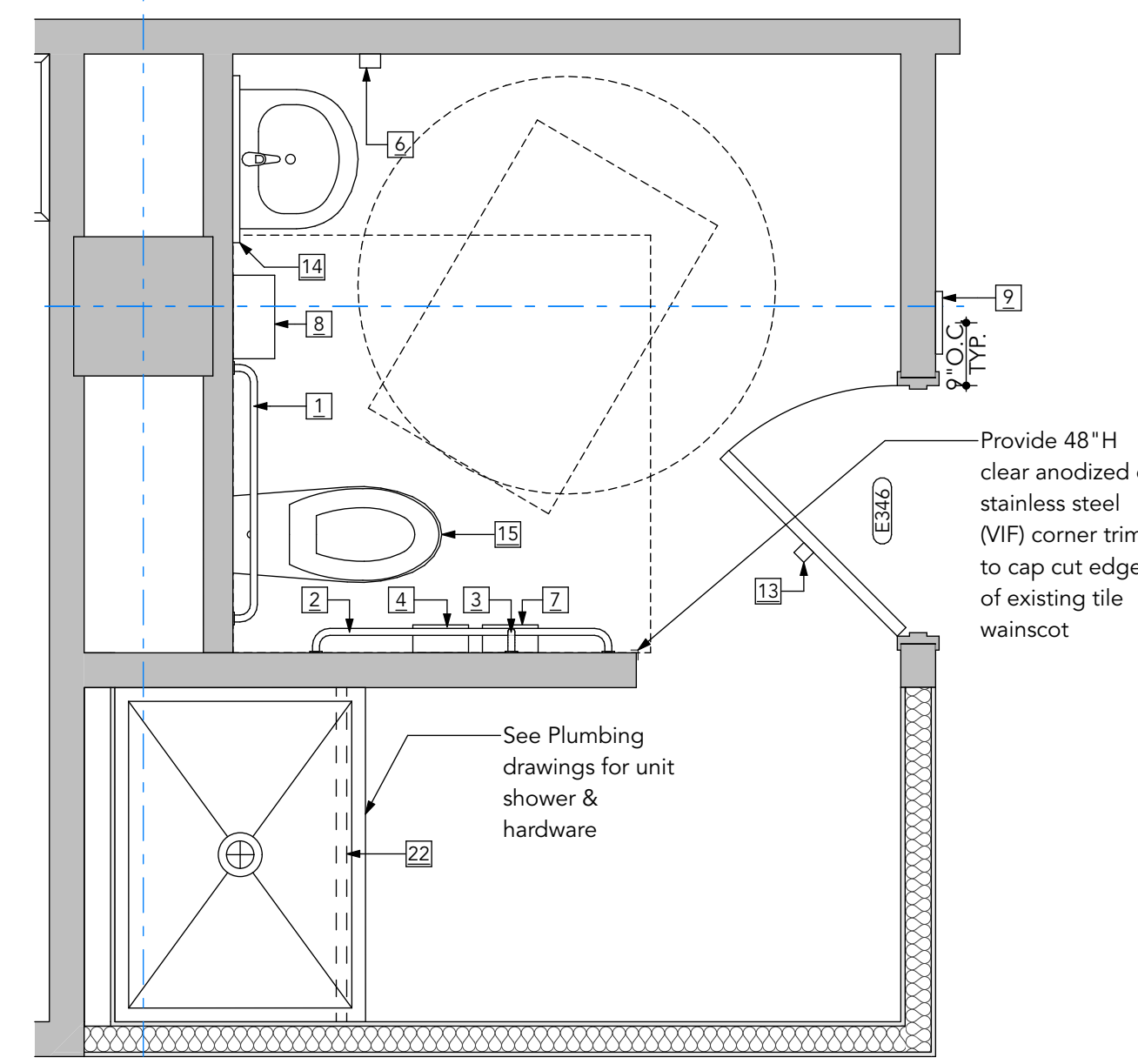
3 Toilet Room #326, #327, #328, Typ.
A106 SCALE: 1/2" = 1'-0"



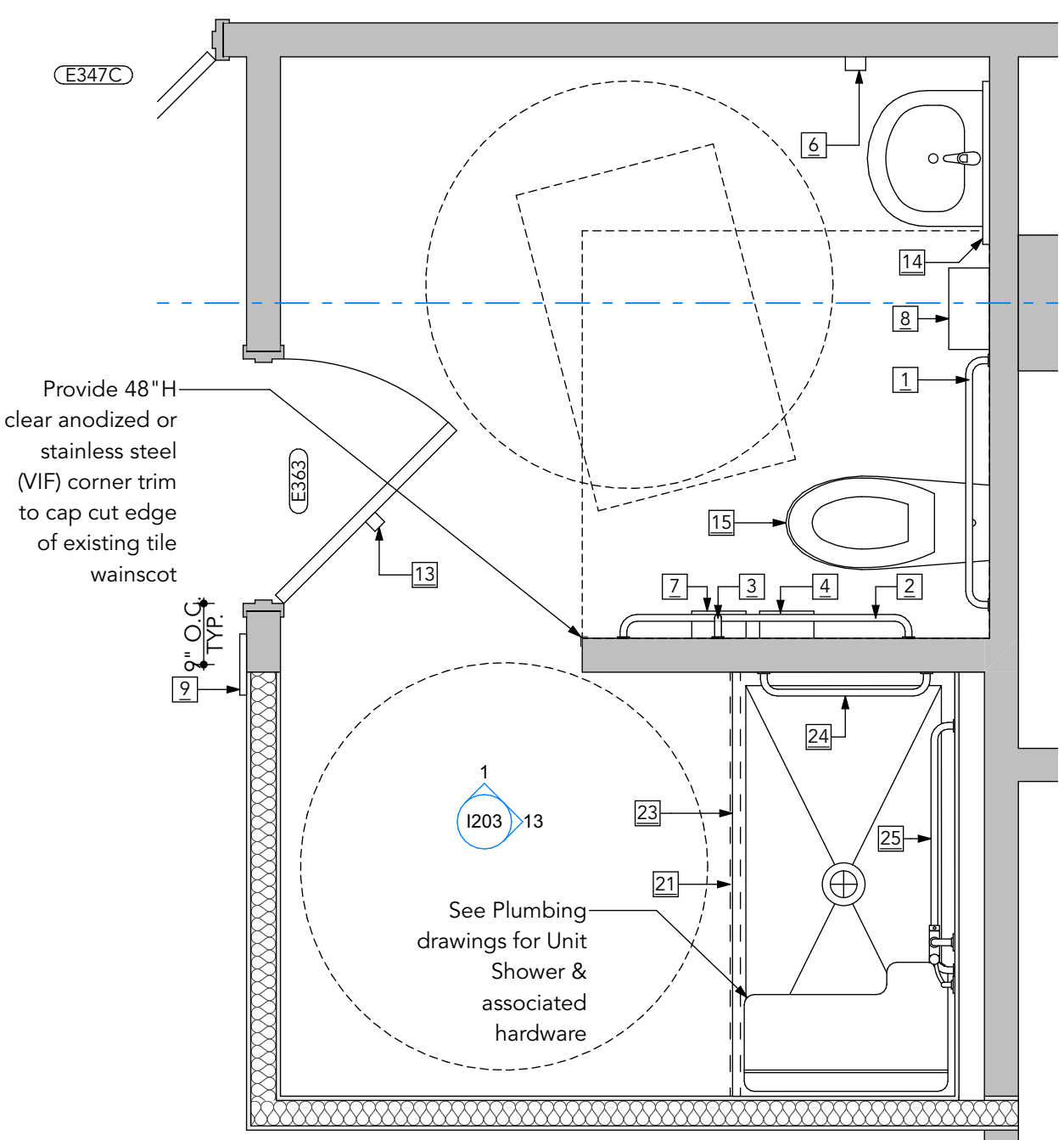
Toilet Room Finish Clarification

- Remove wall covering (TRS #253/251), prepare wall for paint finish
- Skim over textured surface (Rooms#: 122/124, 173/174, 368/369), & prepare wall for paint finish
- Existing wainscot tile & border to remain
- Extent of Floor Tile & Cove Base to be replaced (See Alternate #1)

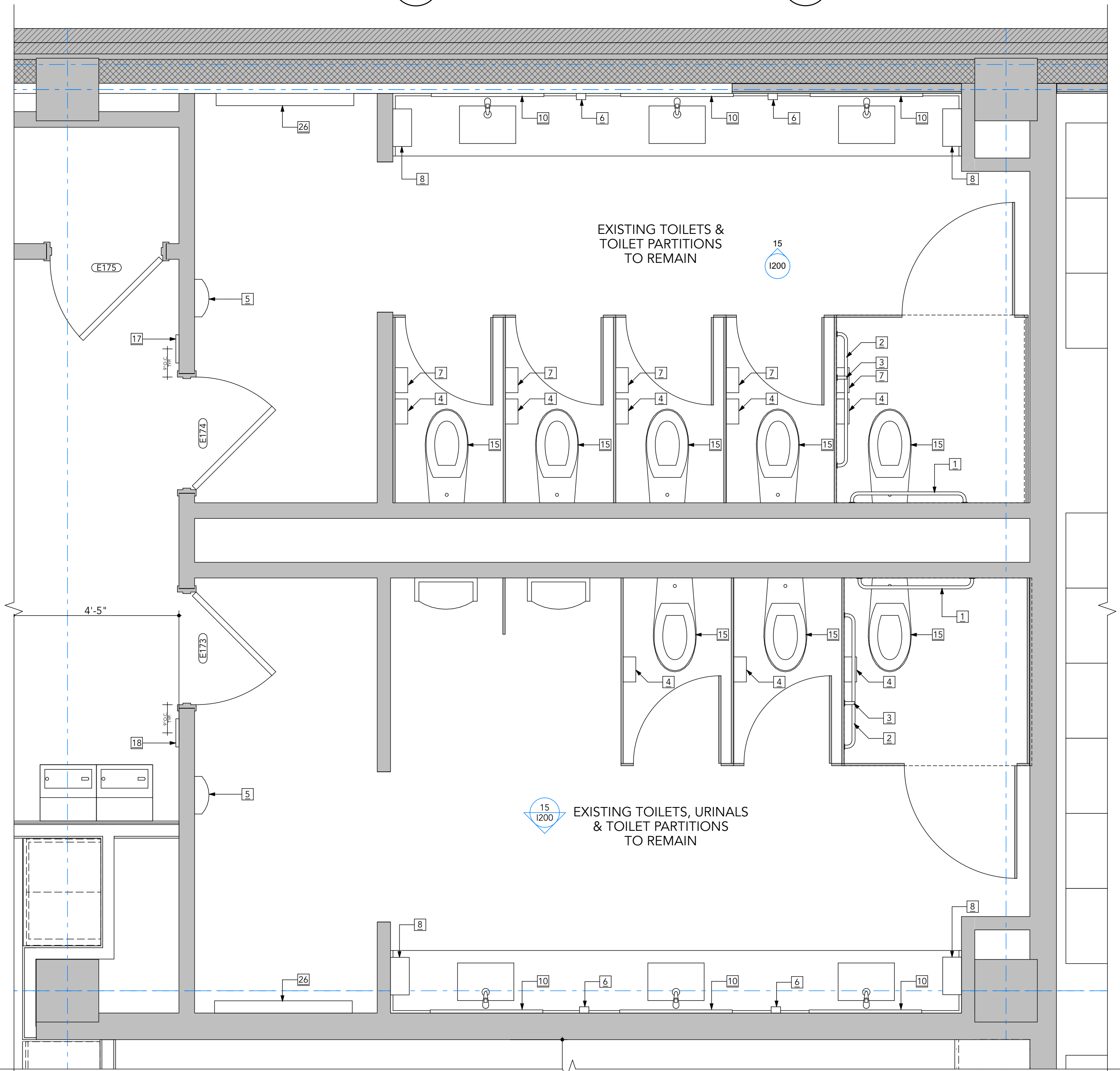
NOTE: See G Sheets for ADA mounting heights & accessory placement.



5 Shower Plan #346
A106 SCALE: 1/2" = 1'-0"



4 Shower Plan #363 - Accessible
A106 SCALE: 1/2" = 1'-0"



See Floor Plans for Fixture Qty & Layout of other multi-user toilet rooms
1 Typical Toilet Room Renovation Plans
A106 SCALE: 1/2" = 1'-0"

NOT FOR REGULATORY APPROVAL, PERMITTING, OR CONSTRUCTION

Bid Set 08/21/2025
Site Plan Review 07/31/2025
DD Set 07/03/2025
© 2025, intersect studio, llc
Project Number: 23-046

Enlarged Toilet Room Plan and Schedule

NOT FOR
 REGULATORY
 APPROVAL,
 PERMITTING, OR
 CONSTRUCTION

Bid Set 08/21/2025
 Site Plan Review 07/31/2025
 DD Set 07/03/2025
 © 2025, Intersect studio, llc
 Project Number: 23-046

Reflected Ceiling
 Main Level Plan -
 CPED

A107

RCP Notes

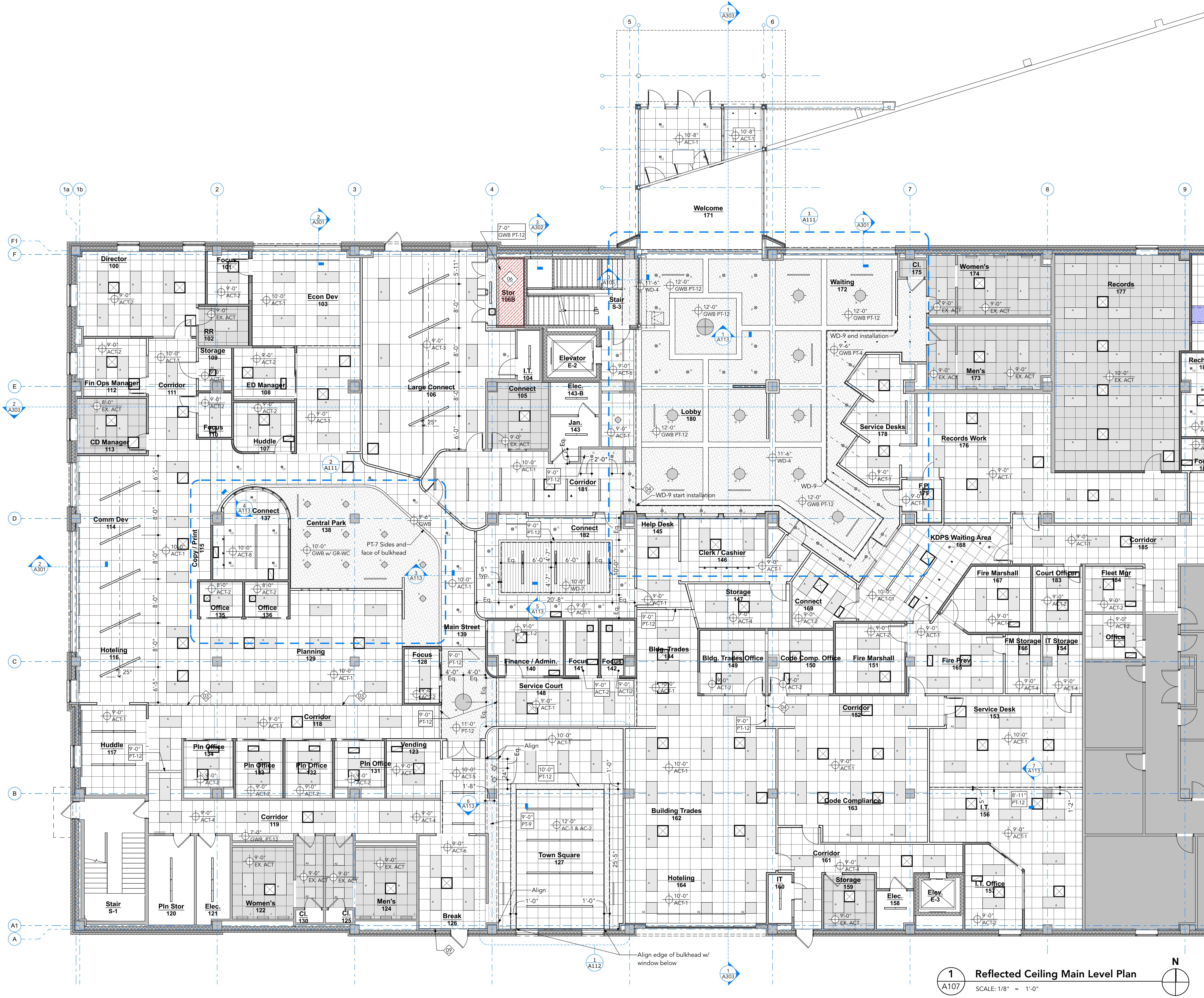
- See A110 for lighting schedule and mounting height information. Lighting is shown for location & type. Refer to electrical drawings for lighting specifications and additional requirements.
- All lighting fixtures are Basis of Design unless noted otherwise & to be approved by owner/architect prior to ordering.
- See Interiors sheets for finish information & room finish schedule.
- Contractor responsible for reviewing specs and providing all necessary supporting accessories and lamping for lighting to be fully functional.
- See Mechanical Sheets for locations of ceiling diffusers and other information.
- Center lights in ceiling tiles, typ., UNO. Dimensions are to the centerline of light fixtures, unless noted otherwise.

RCP Keynotes

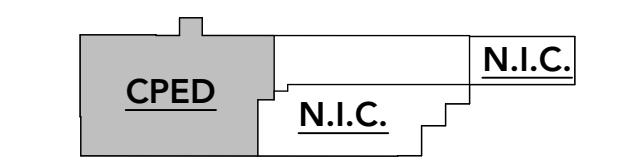
- ① Open ceiling & deck be painted PT-3 above 9'-6" AFF including ductwork, conduit, piping & equipment.
- ② Open ceiling & deck be painted PT-12 above 9'-0" AFF including ductwork, conduit, piping & equipment.
- ③ Transition between lay-in ceiling heights - use Armstrong Axiom Transition Trim AXTR125TR.
- ④ Bulkhead @ location of prev. existing wall. Cap partition studs @ height shown.
- ⑤ 1-Hr Rated horizontal shaft wall duct chase (Wall Assembly C1) above decorative gyp. bd. ceiling within rated egress corridor. See section detail.
- ⑥ 1-Hr Rated ceiling assembly under stair. (Wall Assembly A1C).
- ⑦ Opening for motorized overhead ceiling grille.

RCP Key

- New ACT
- Exist ACT
- New Gyp.
- Wood Plank



1 Reflected Ceiling Main Level Plan
 SCALE: 1/8" = 1'-0"



Key Plan - CPED

9/25/25 - BIMcloud: Intersect A107 Network Server - BIMcloud: Intersect A107 Network Server - BIMcloud: Intersect A107 Network Server - BIMcloud: Intersect A107 Network Server

NOT FOR
 REGULATORY
 APPROVAL,
 PERMITTING, OR
 CONSTRUCTION

Bid Set 08/21/2025
 Site Plan Review 07/31/2025
 DD Set 07/03/2025
 © 2025, intersect studio, llc
 Project Number: 23-046

Reflected Ceiling
 Main Level Plan -
 KDPS

A108

RCP Notes

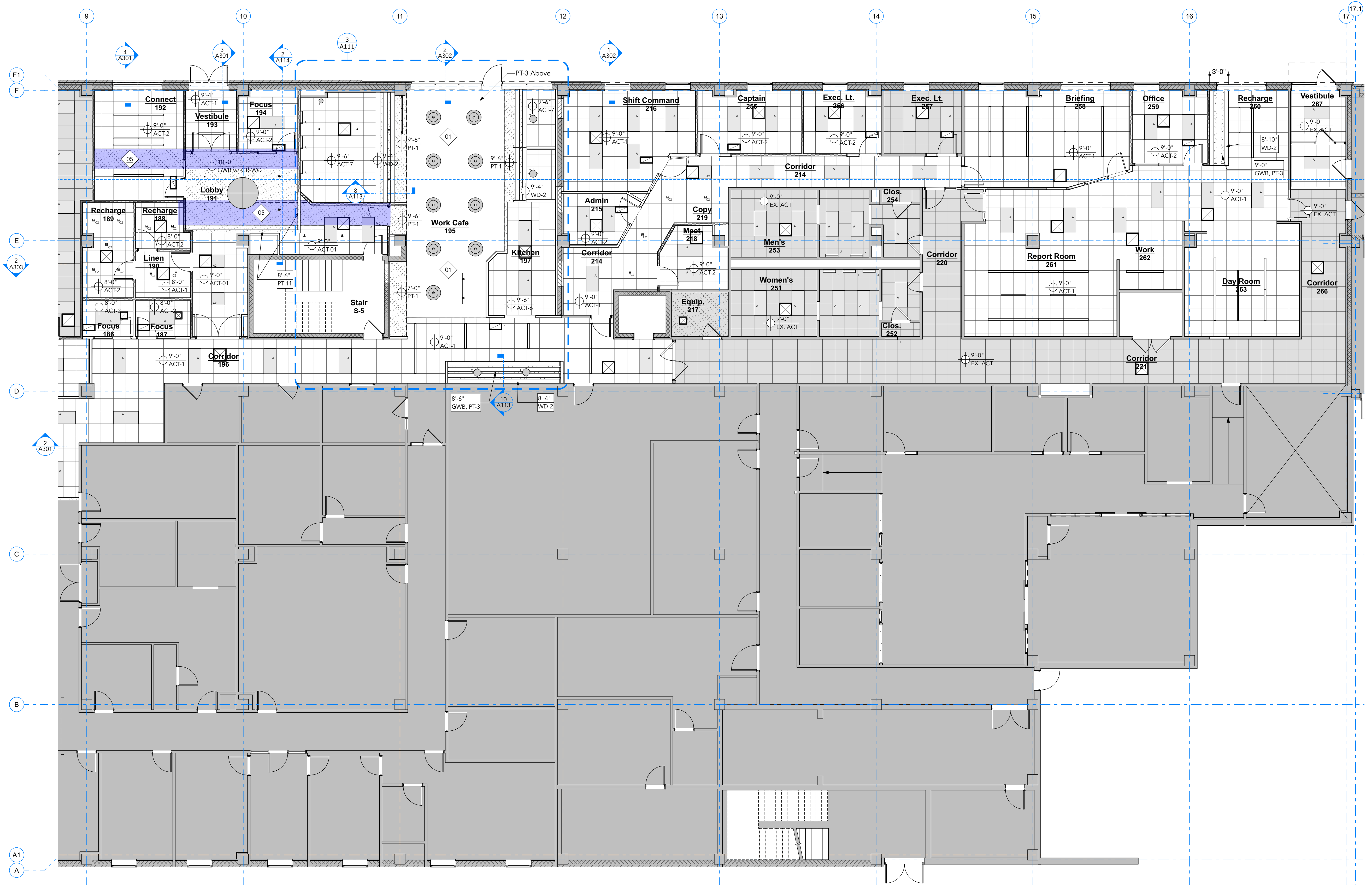
1. See A110 for lighting schedule and mounting height information. Lighting is shown for location & type. Refer to electrical drawings for lighting specifications and additional requirements.
2. All lighting fixtures are Basis of Design unless noted otherwise & to be approved by owner/architect prior to ordering.
3. See Interiors sheets for finish information & room finish schedule.
4. Contractor responsible for reviewing specs and providing all necessary supporting accessories and lamping for lighting to be fully functional.
5. See Mechanical Sheets for locations of ceiling diffusers and other information.
6. Center lights in ceiling tiles, typ., UNO. Dimensions are to the centerline of light fixtures, unless noted otherwise.

RCP Keynotes

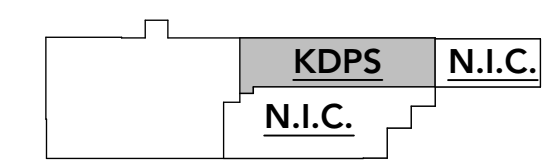
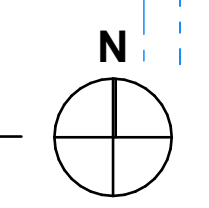
- 01 Open ceiling & deck be painted PT-3 above 9'-6" AFF including ductwork, conduit, piping & equipment.
- 02 Open ceiling & deck be painted PT-12 above 9'-0" AFF including ductwork, conduit, piping & equipment.
- 03 Transition between lay-in ceiling heights - use Armstrong Axiom Transition Trim AXTR125TR.
- 04 Bulkhead @ location of prev. existing wall. Cap partition studs @ height shown.
- 05 1-Hr Rated horizontal shaft wall duct chase (Wall Assembly C1) above decorative gyp. bd. ceiling within rated egress corridor. See section detail.
- 06 1-Hr Rated ceiling assembly under stair. (Wall Assembly A1C).
- 07 Opening for motorized overhead ceiling grille.

RCP Key

- New ACT
- Exist ACT
- New Gyp.
- Wood Plank



1 Reflected Ceiling Main Level Plan
 A108 SCALE: 1/8" = 1'-0"



Key Plan - KDPS

8/25/25 - BIMcloud: Intersect AC27 Network Server - BIMcloud Basic for Archical 27/25/25 Koo Crosstown Facility

NOT FOR
 REGULATORY
 APPROVAL,
 PERMITTING, OR
 CONSTRUCTION

Bid Set 08/21/2025
 Site Plan Review 07/31/2025
 DD Set 07/03/2025
 © 2025, intersect studio, llc
 Project Number: 23-046

Reflected Ceiling
 Upper Level Plan -
 CPED

RCP Notes

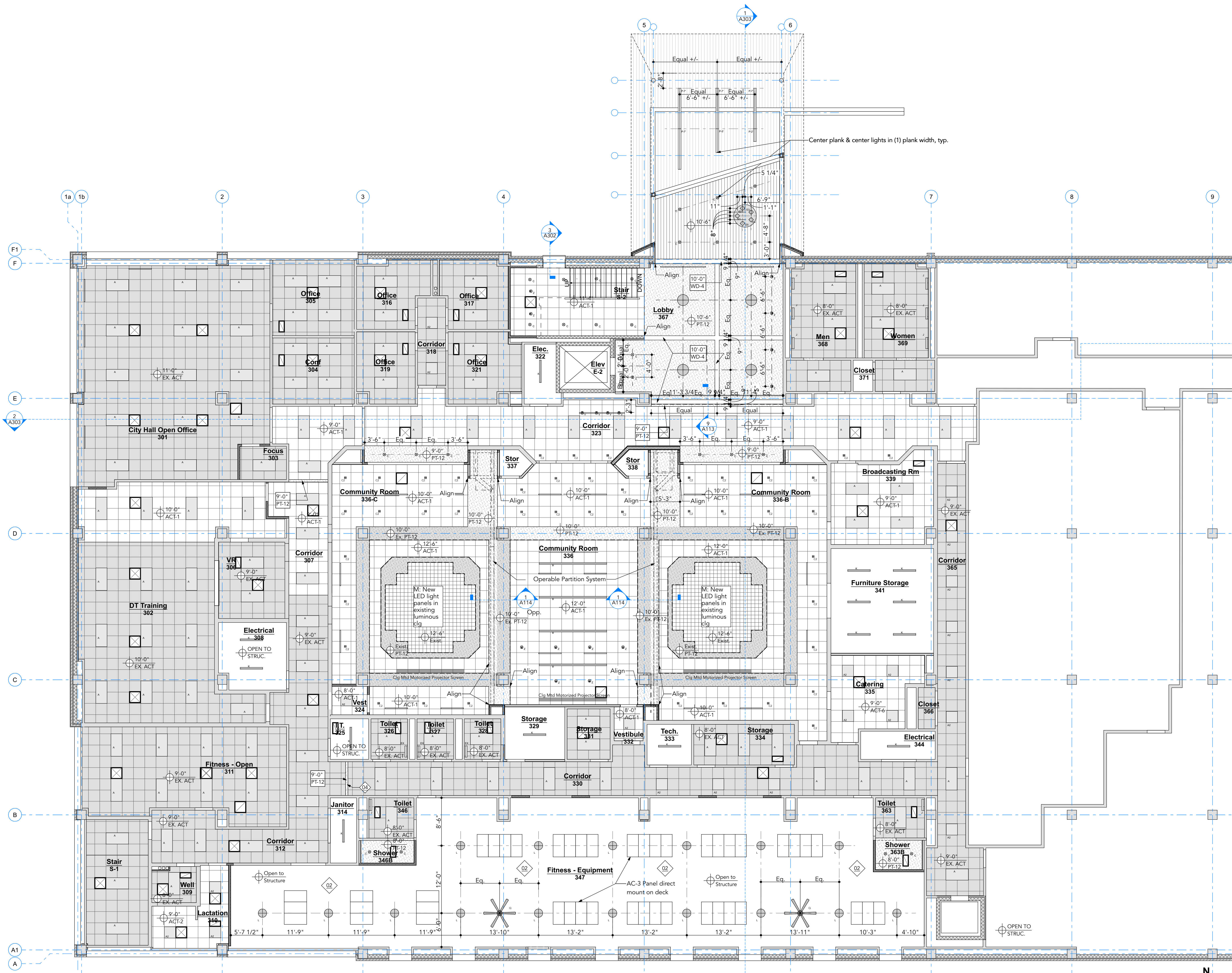
- See A110 for lighting schedule and mounting height information. Lighting is shown for location & type. Refer to electrical drawings for lighting specifications and additional requirements.
- All lighting fixtures are Basis of Design unless noted otherwise & to be approved by owner/architect prior to ordering.
- See Interiors sheets for finish information & room finish schedule.
- Contractor responsible for reviewing specs and providing all necessary supporting accessories and lamping for lighting to be fully functional.
- See Mechanical Sheets for locations of ceiling diffusers and other information.
- Center lights in ceiling tiles, typ., UNO. Dimensions are to the centerline of light fixtures, unless noted otherwise.

RCP Keynotes

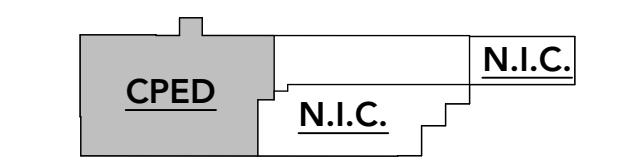
- Ⓛ1 Open ceiling & deck be painted PT-3 above 9'-6" AFF including ductwork, conduit, piping & equipment.
- Ⓛ2 Open ceiling & deck be painted PT-12 above 9'-0" AFF including ductwork, conduit, piping & equipment.
- Ⓛ3 Transition between lay-in ceiling heights - use Armstrong Axiom Transition Trim AXTR12STR.
- Ⓛ4 Bulkhead @ location of prev. existing wall. Cap partition studs @ height shown.
- Ⓛ5 1-Hr Rated horizontal shaft wall duct chase (Wall Assembly C1) above decorative gyp. bd. ceiling within rated egress corridor. See section detail.
- Ⓛ6 1-Hr Rated ceiling assembly under stair. (Wall Assembly A1C).
- Ⓛ7 Opening for motorized overhead ceiling grille.

RCP Key

- New ACT
- Exist ACT
- New Gyp.
- Wood Plank



1 Reflected Ceiling Upper Level Plan
 A109 SCALE: 1/8" = 1'-0"



Key Plan - CPED

9/25/25 - BIMModel: Intersect-AC27 - Network: Server - BIMModel: Intersect-AC27 - Network: Server - BIMModel: Intersect-AC27 - Network: Server - BIMModel: Intersect-AC27 - Network: Server

NOT FOR
 REGULATORY
 APPROVAL,
 PERMITTING, OR
 CONSTRUCTION

Bid Set 08/21/2025
 Site Plan Review 07/31/2025
 DD Set 07/03/2025
 © 2025, intersect studio, llc
 Project Number: 23-046

Enlarged
 Reflected Ceiling
 Plans

A111

RCP Notes

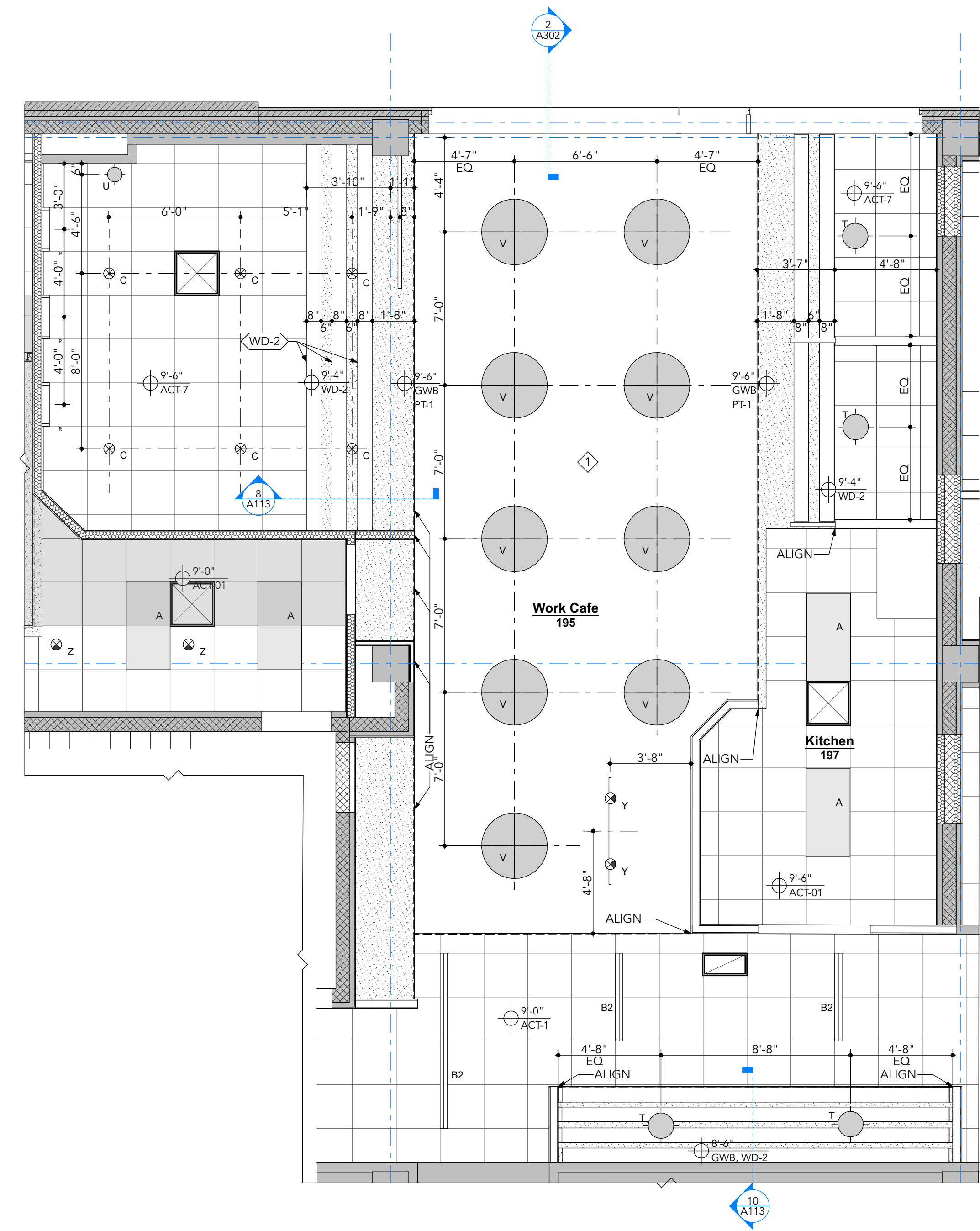
- See A110 for lighting schedule and mounting height information. Lighting is shown for location & type. Refer to electrical drawings for lighting specifications and additional requirements.
- All lighting fixtures are Basis of Design unless noted otherwise & to be approved by owner/architect prior to ordering.
- See Interiors sheets for finish information & room finish schedule.
- Contractor responsible for reviewing specs and providing all necessary supporting accessories and lamping for lighting to be fully functional.
- See Mechanical Sheets for locations of ceiling diffusers and other information.
- Center lights in ceiling bays. Dimensions are to the centerline of light fixtures, unless noted otherwise.

RCP Keynotes

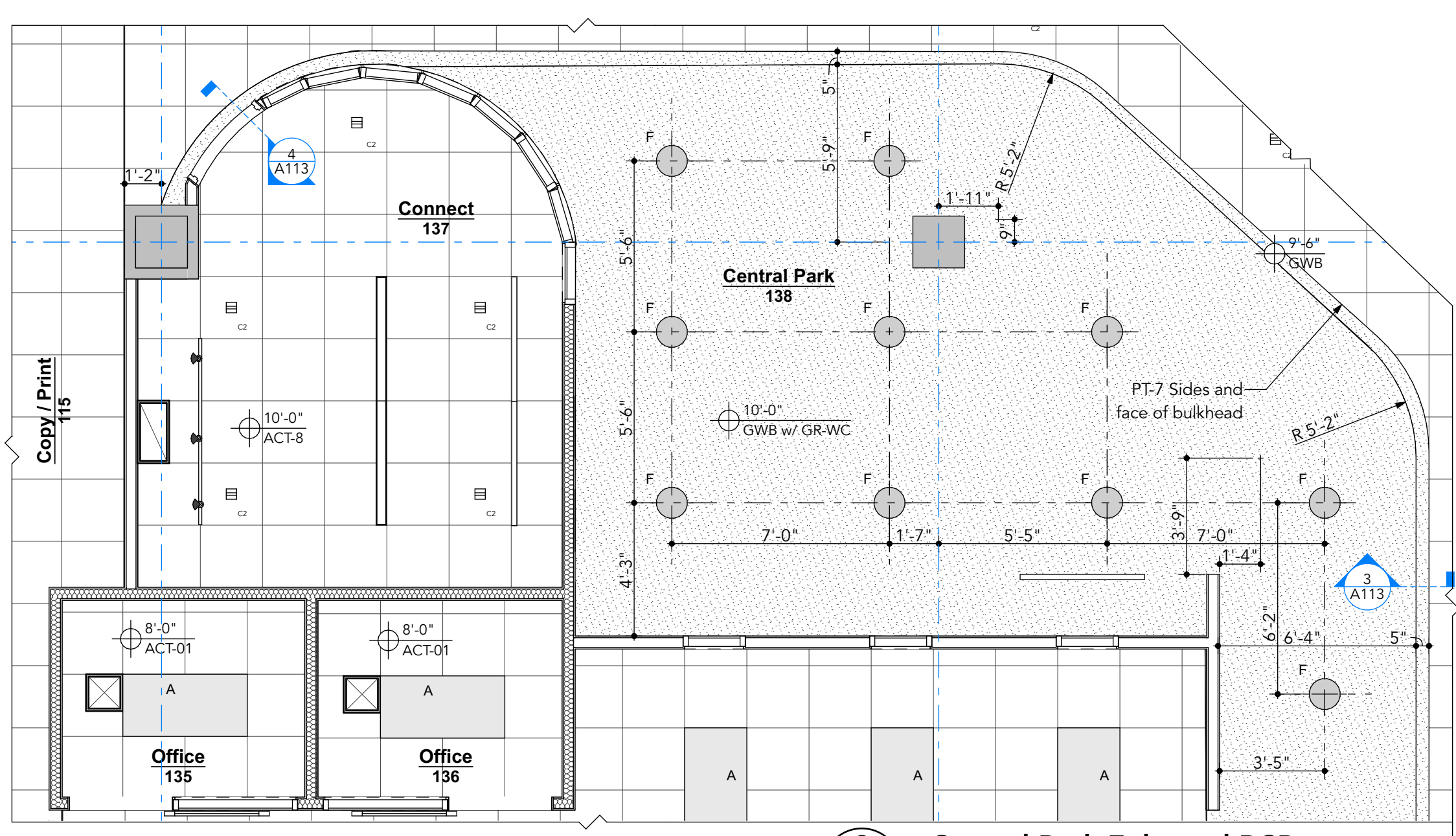
- ① Open ceiling & deck be painted PT-3 above 9'-6" AFF including ductwork, conduit, piping & equipment.
- ② Open ceiling & deck be painted PT-12 above 9'-0" AFF including ductwork, conduit, piping & equipment.
- ③ Transition between lay-in ceiling heights - use Armstrong Axiom Transition Trim AXTR12STR.
- ④ Center light in ceiling bay.

RCP Key

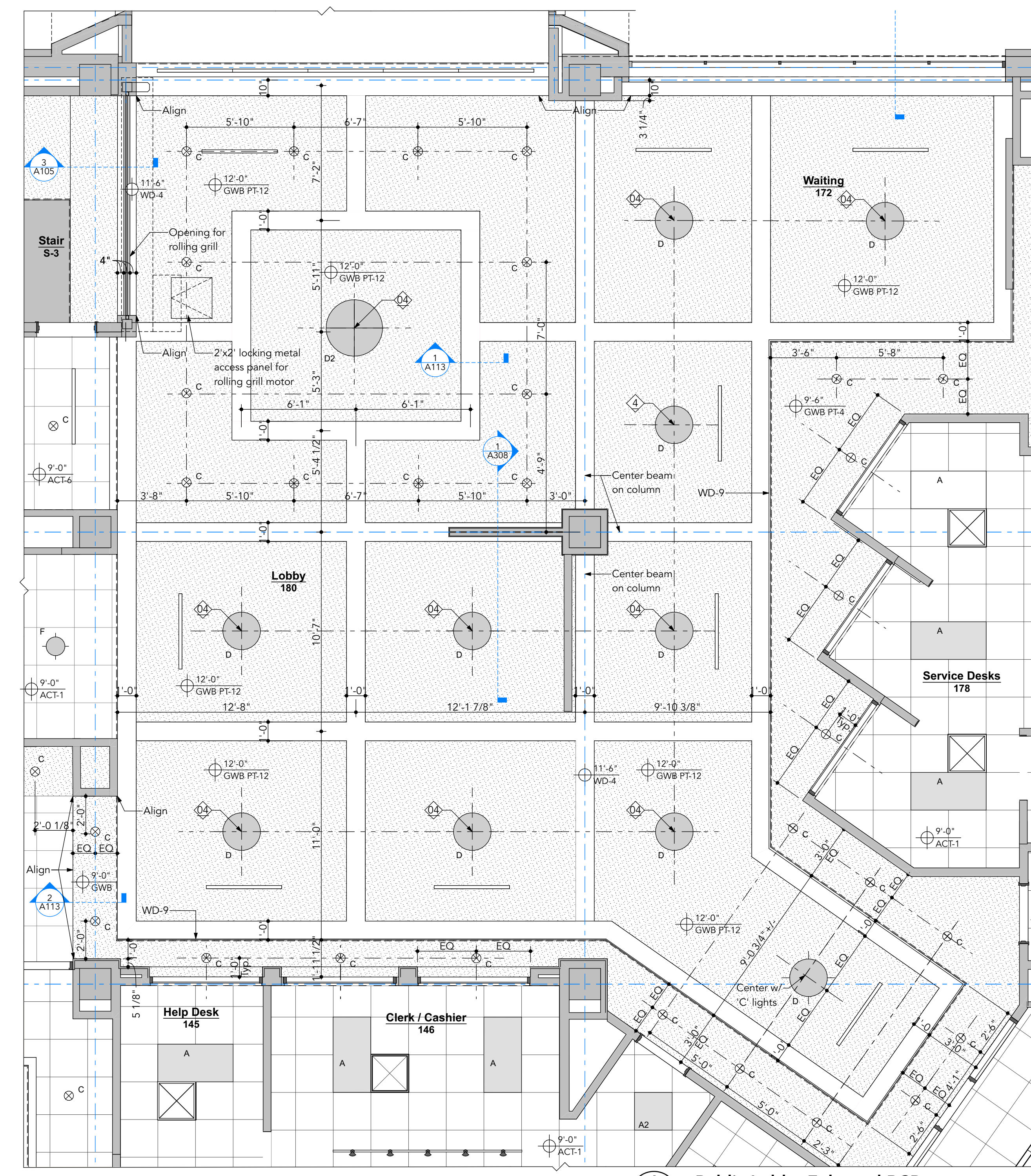
- New ACT
- Exist ACT
- New Gyp.
- Wood Plank



3 Work Cafe Enlarged RCP
 A111 SCALE: 1/4" = 1'-0"

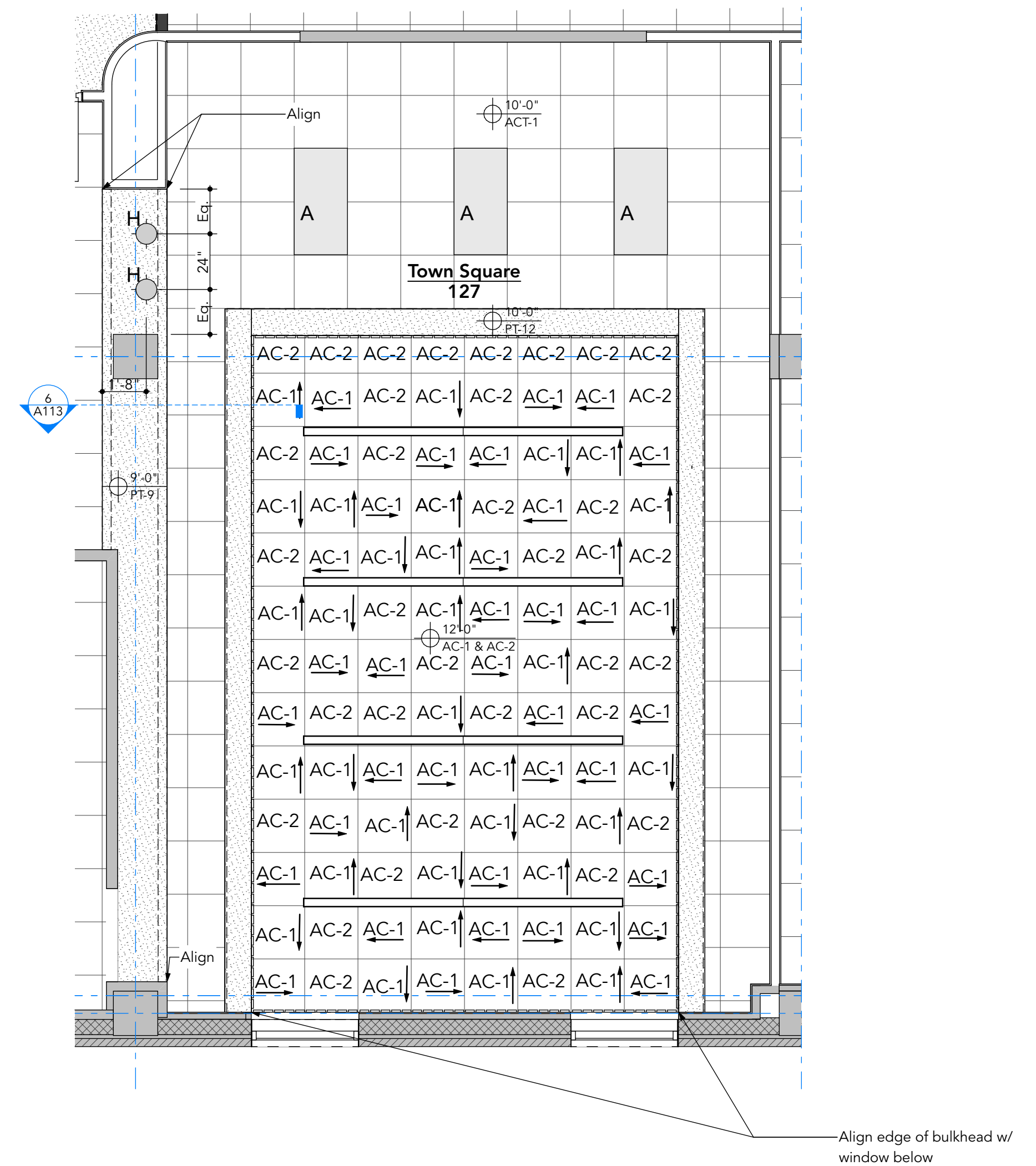


2 Central Park Enlarged RCP
 A111 SCALE: 1/4" = 1'-0"



1 Public Lobby Enlarged RCP
 A111 SCALE: 1/4" = 1'-0"

8/25/25 - BIMModel: Intersect:ACT27: Framework: Server - BIMModel: Intersect:ACT27: Framework: Server - BIMModel: Intersect:ACT27: Framework: Server - BIMModel: Intersect:ACT27: Framework: Server - BIMModel: Intersect:ACT27: Framework: Server



1
A112 **Town Square Enlarged Ceiling Plan**
SCALE: 1/4" = 1'-0"

NOT FOR
REGULATORY
APPROVAL,
PERMITTING, OR
CONSTRUCTION

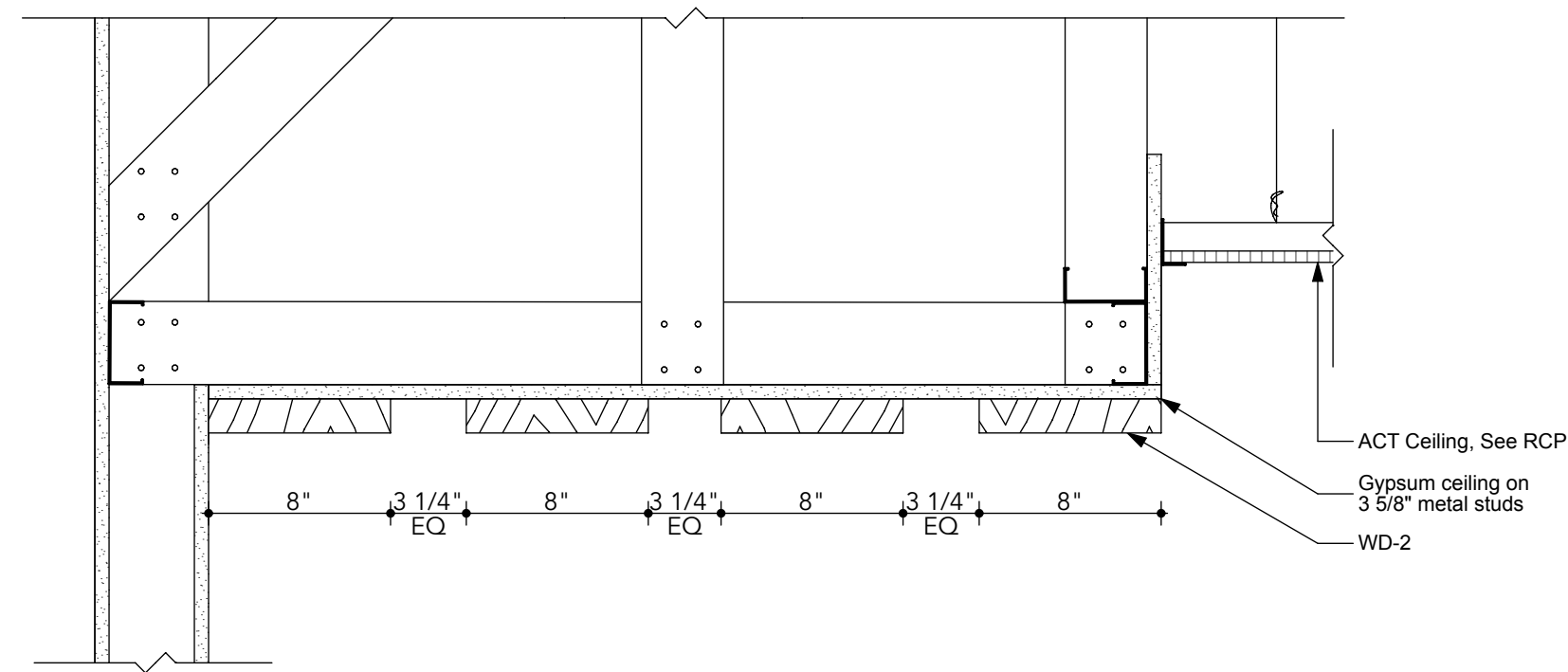
Bid Set 08/21/2025
Site Plan Review 07/31/2025
DD Set 07/03/2025
© 2025, intersect studio, llc
Project Number: 23-046

**Enlarged
Reflected Ceiling
Plans**

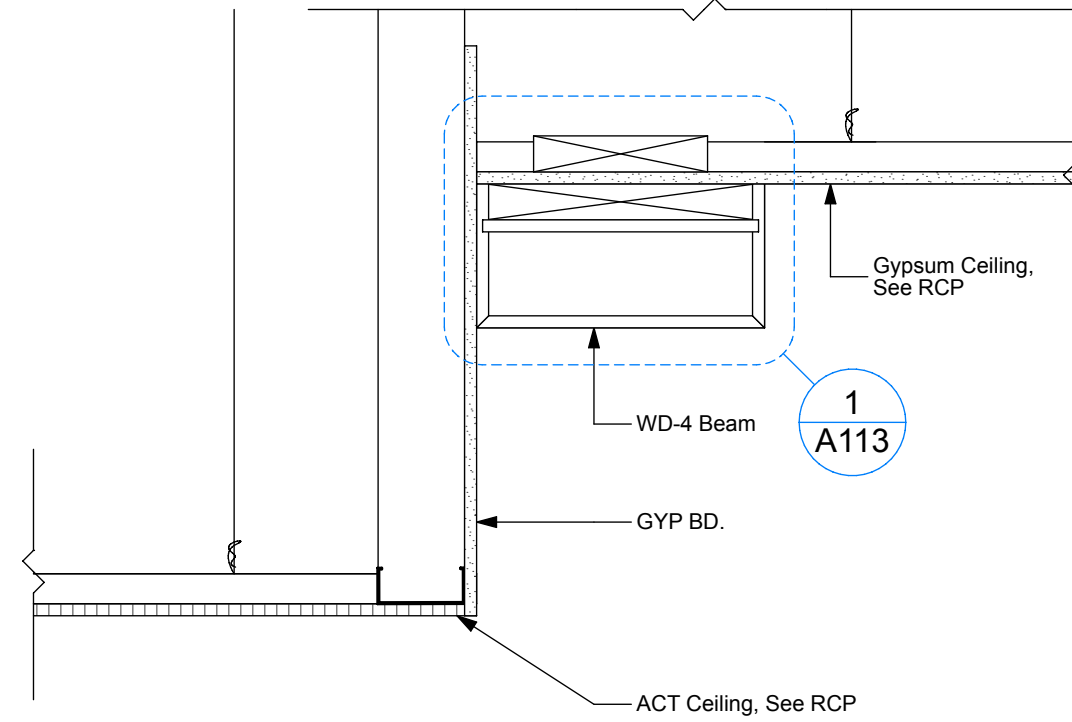
NOT FOR
 REGULATORY
 APPROVAL,
 PERMITTING, OR
 CONSTRUCTION

Bid Set 08/21/2025
 Site Plan Review 07/31/2025
 DD Set 07/03/2025
 © 2025, intersect studio, llc
 Project Number: 23-046

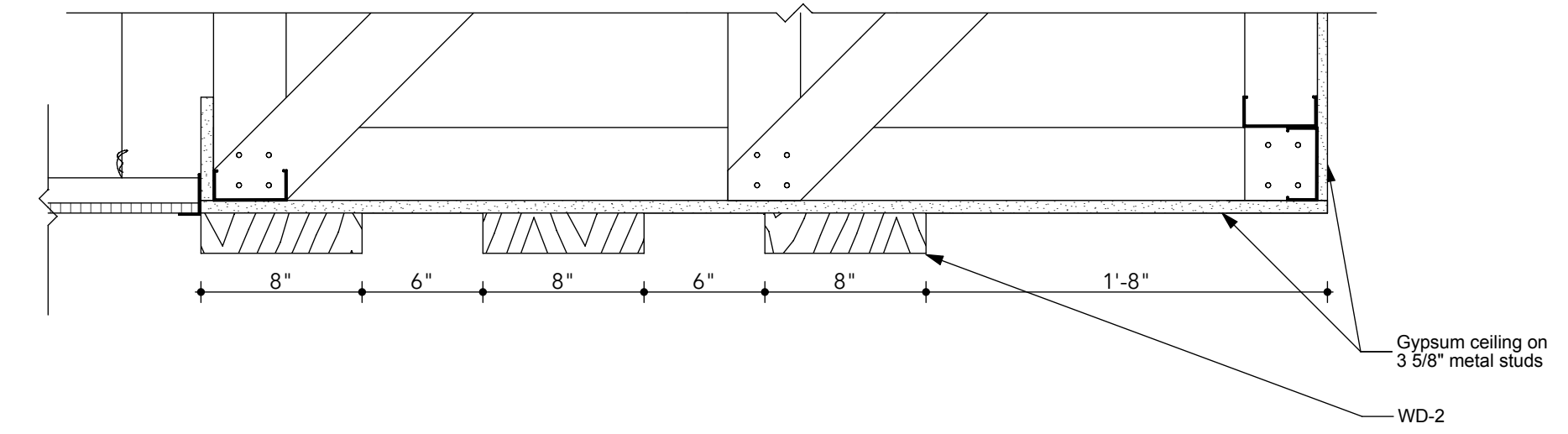
Ceiling Details



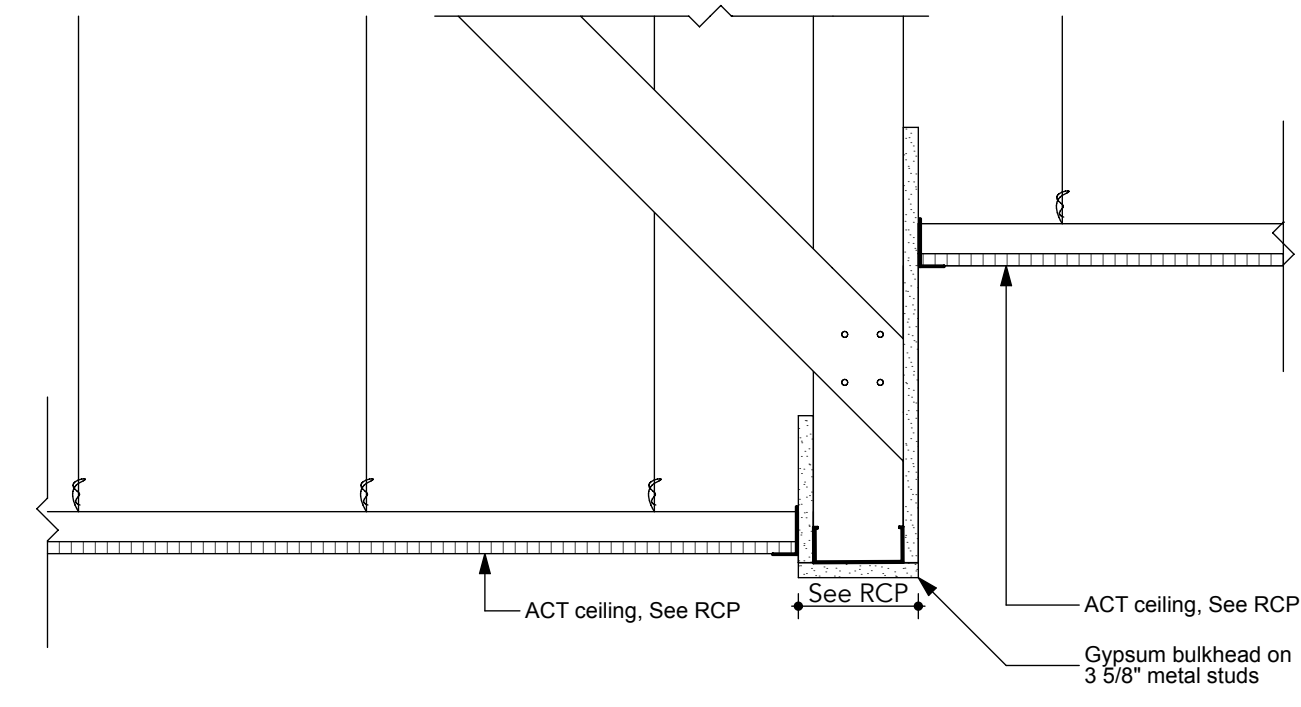
10 Upper Level Lobby to Corridor Transition Detail
 A113 SCALE: 1 1/2" = 1'-0"



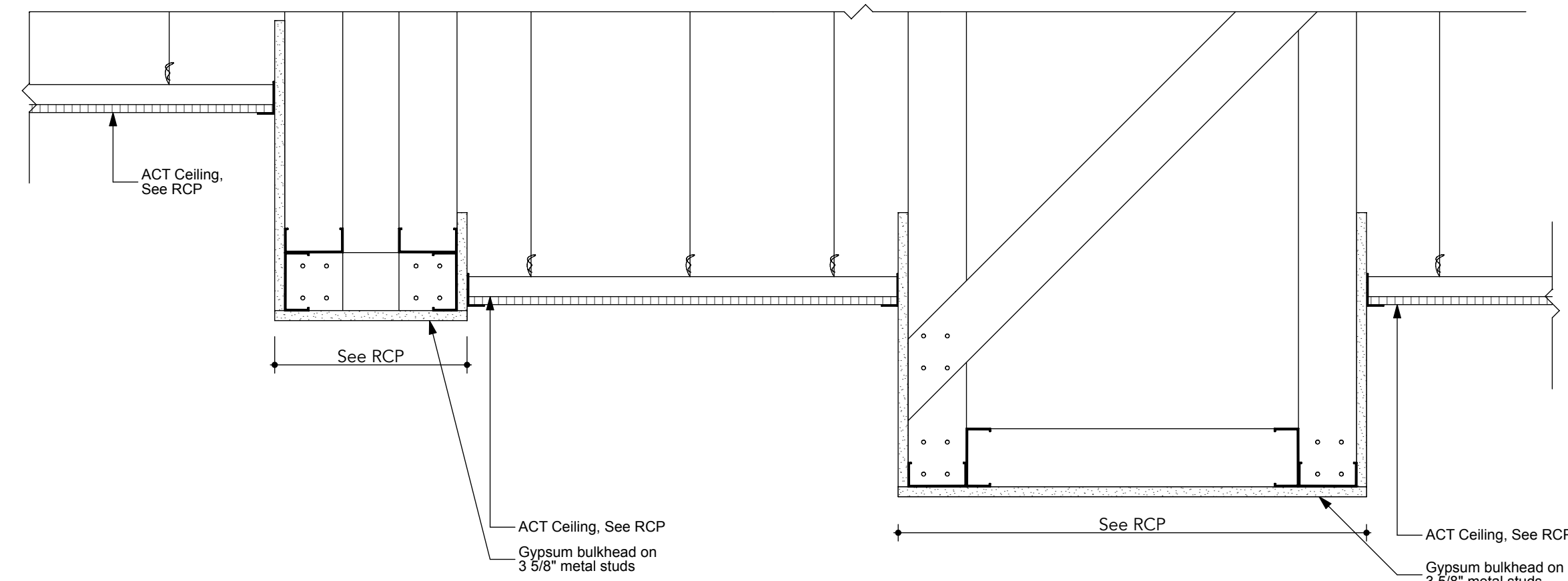
9 Upper Level Lobby to Corridor Transition Detail
 A113 SCALE: 1 1/2" = 1'-0"



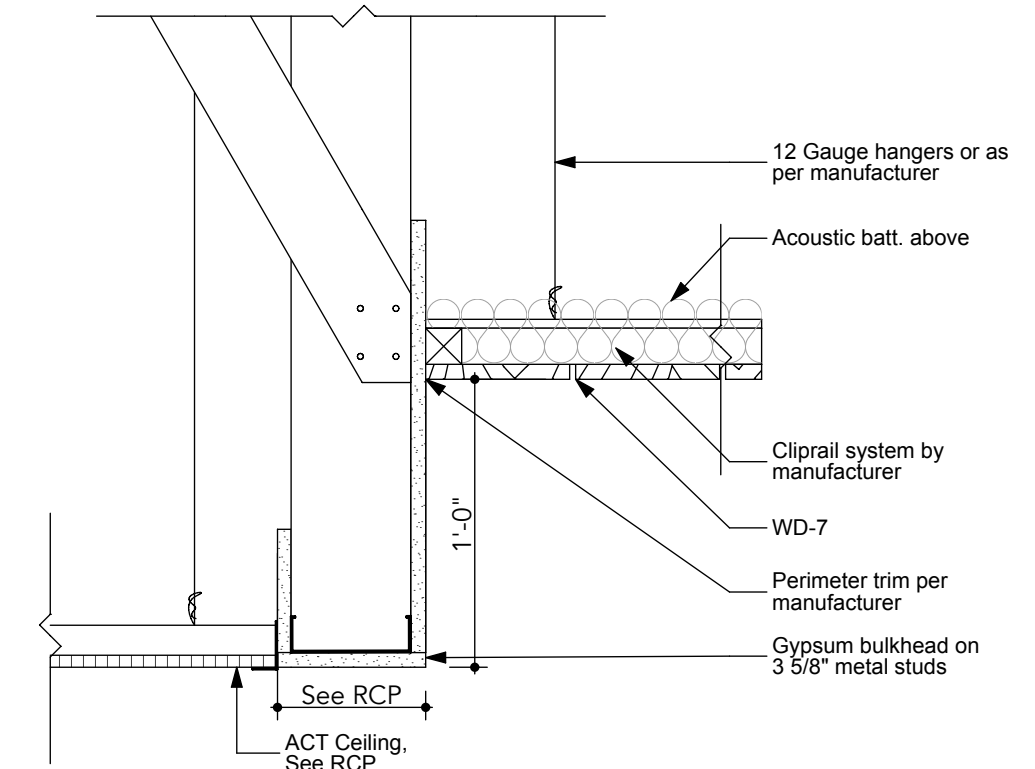
8 Work Cafe Ceiling Detail
 A113 SCALE: 1 1/2" = 1'-0"



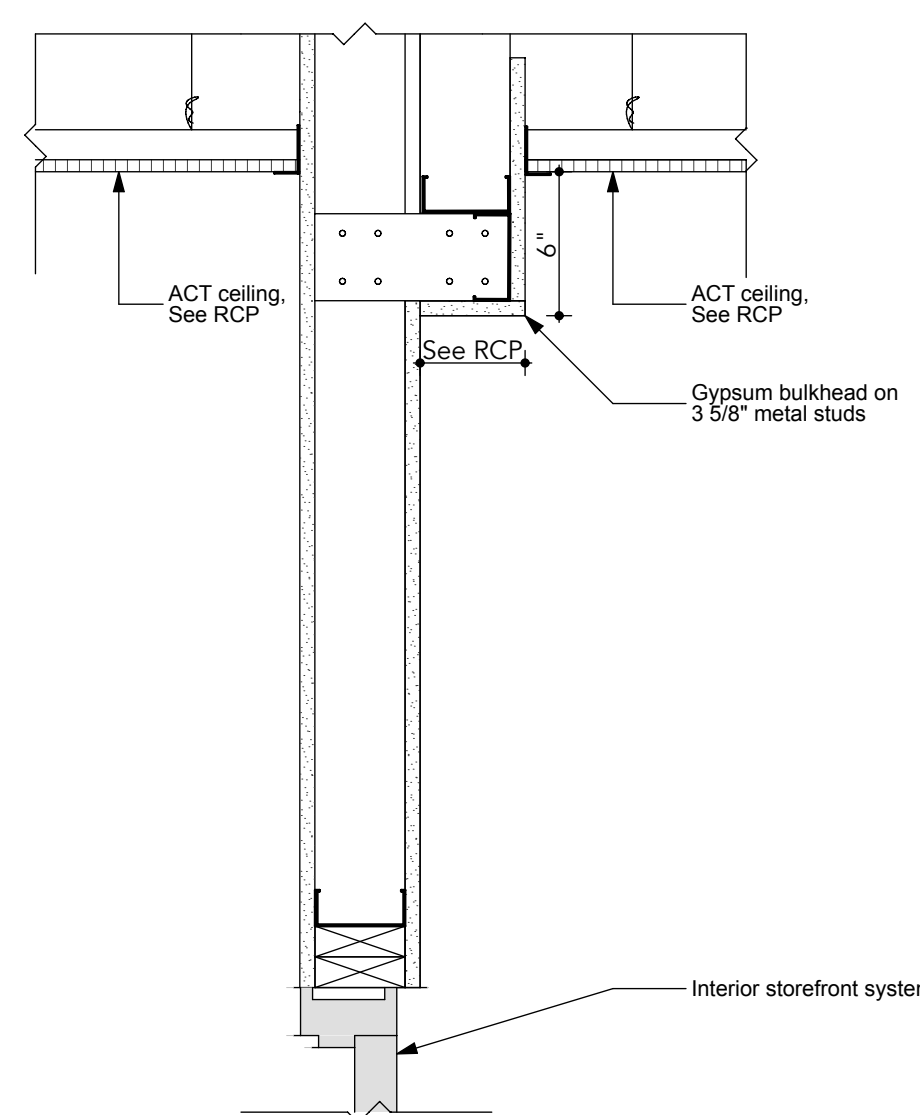
7 Service Desk Ceiling Detail
 A113 SCALE: 1 1/2" = 1'-0"



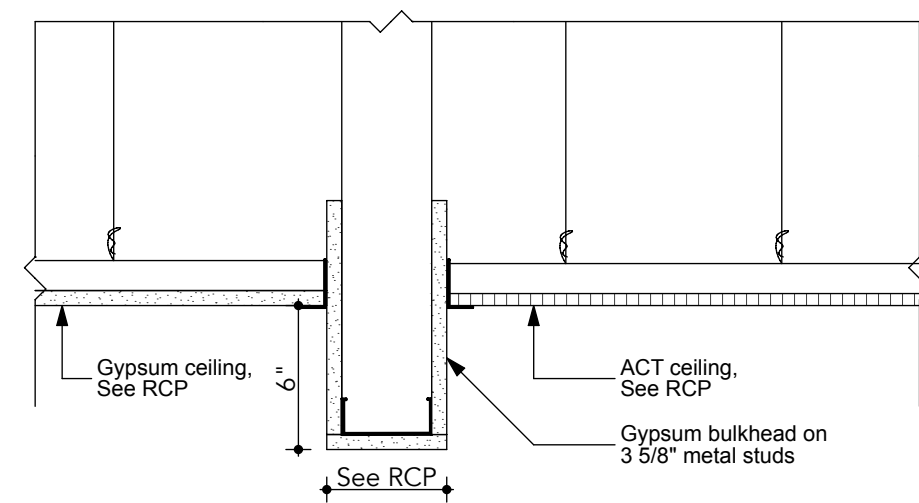
6 Town Square Ceiling Detail at Entry
 A113 SCALE: 1 1/2" = 1'-0"



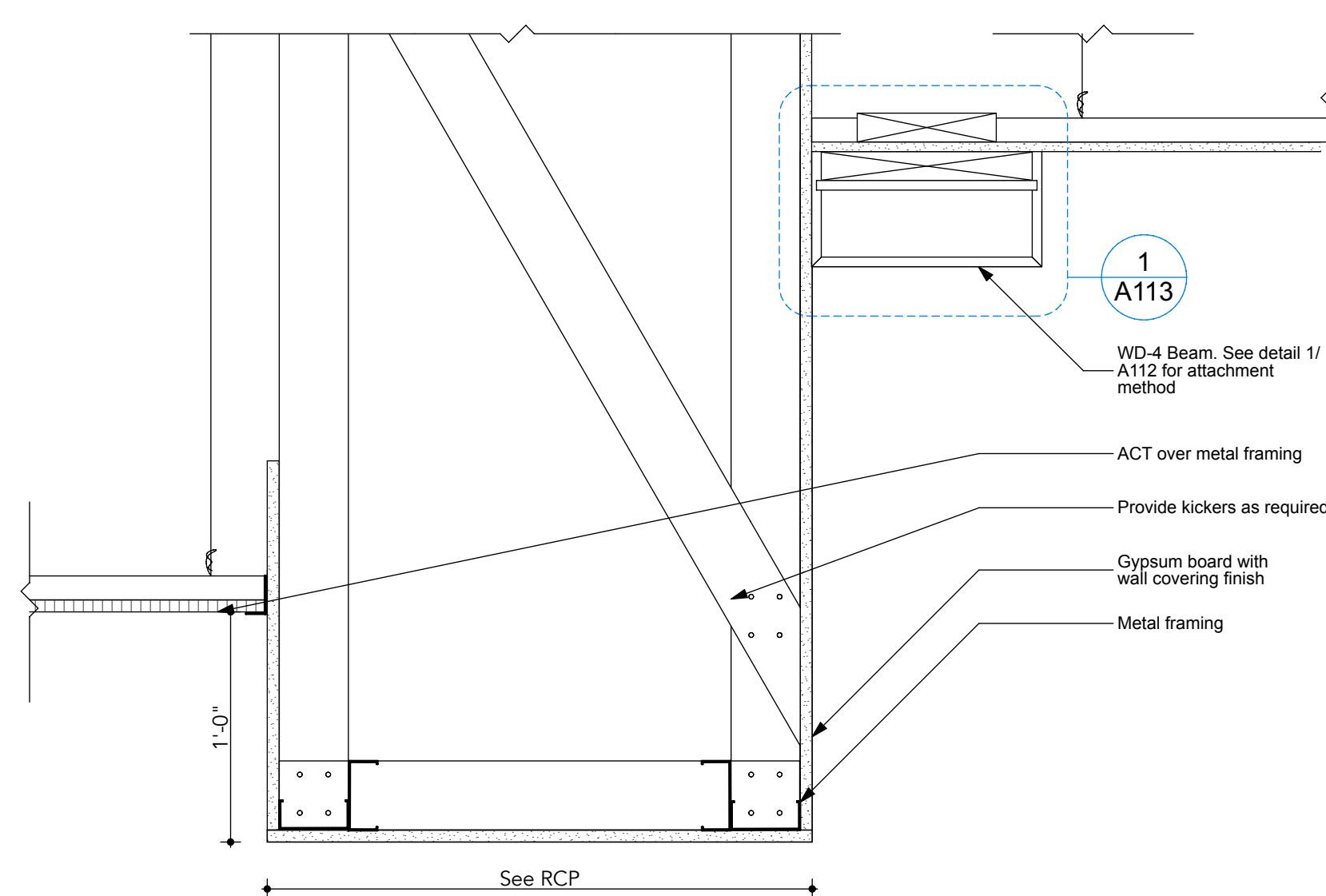
5 Connect 182 Wood Ceiling Detail
 A113 SCALE: 1 1/2" = 1'-0"



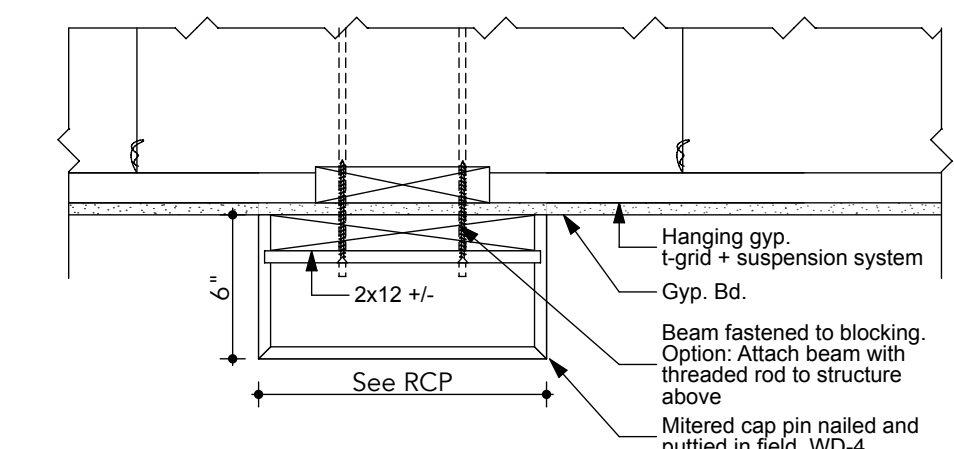
4 Connect 137 to Corridor Transition Detail
 A113 SCALE: 1 1/2" = 1'-0"



3 Central Park to Main Street Transition Detail: Gyp to ACT
 A113 SCALE: 1 1/2" = 1'-0"



2 Corridor to Lobby Transition Detail
 A113 SCALE: 1 1/2" = 1'-0"

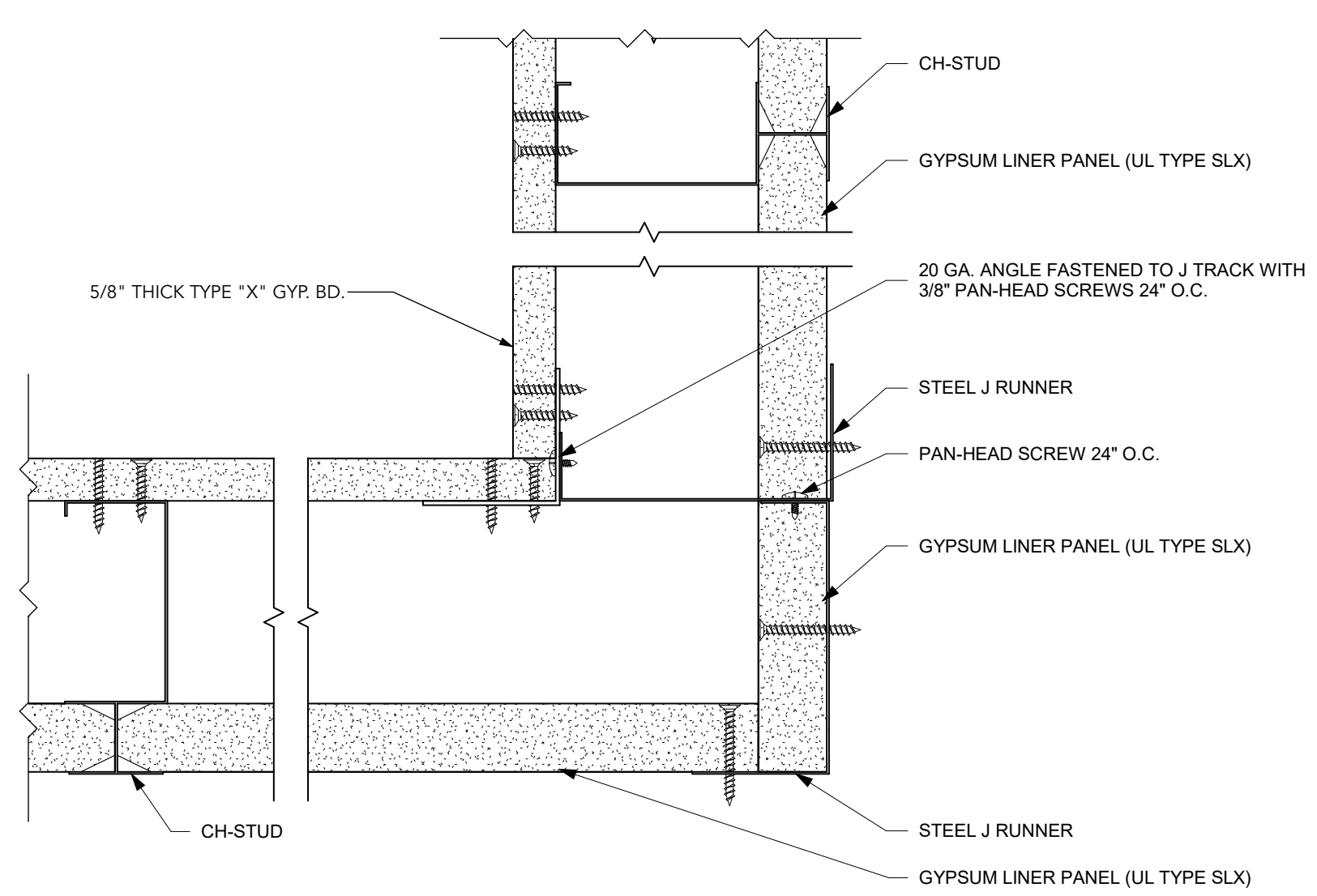


1 Lobby Ceiling Detail
 A113 SCALE: 1 1/2" = 1'-0"

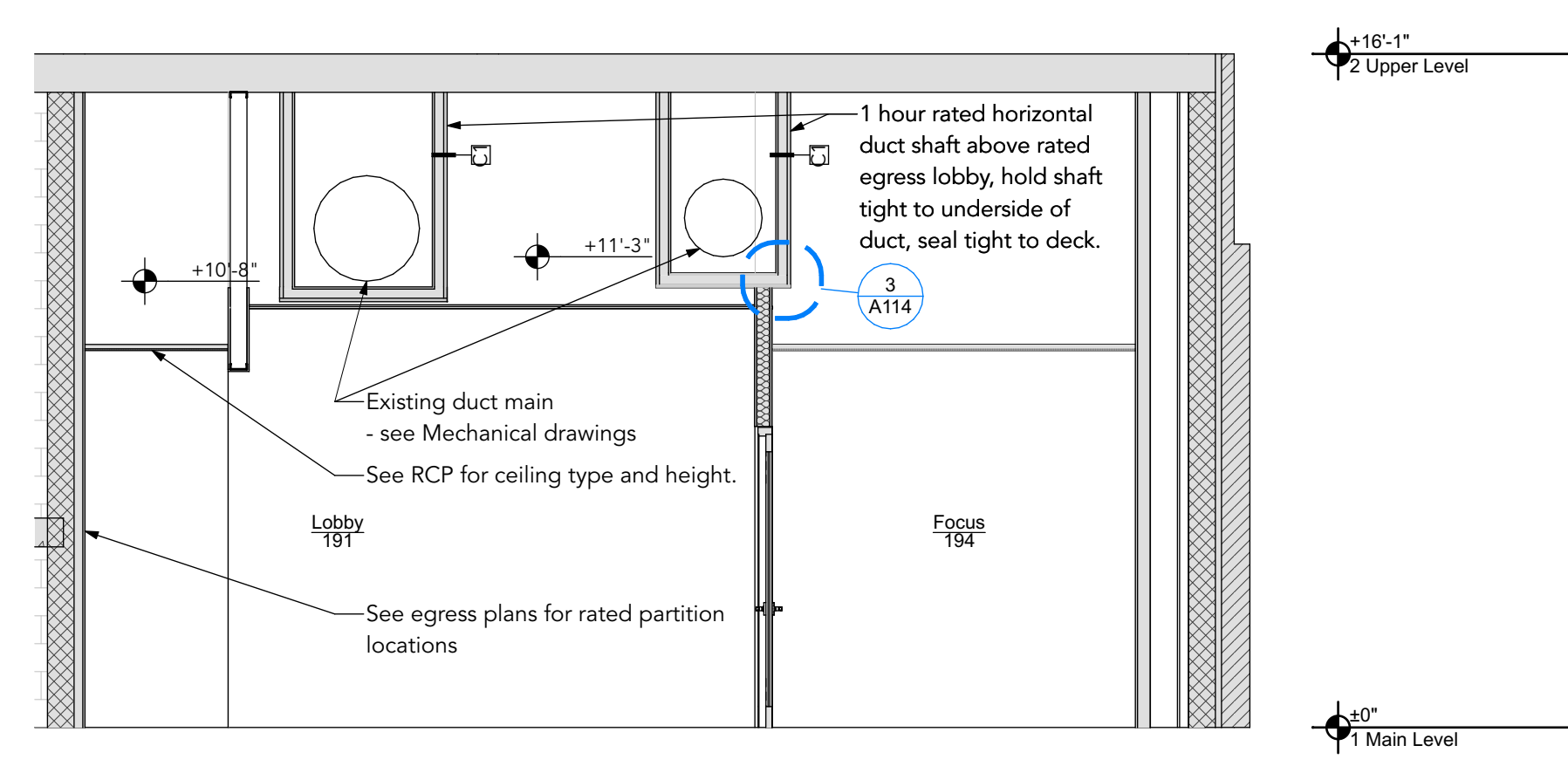
NOT FOR
 REGULATORY
 APPROVAL,
 PERMITTING, OR
 CONSTRUCTION

Bid Set 08/21/2025
 Site Plan Review 07/31/2025
 DD Set 07/03/2025
 © 2025, intersect studio, llc
 Project Number: 23-046

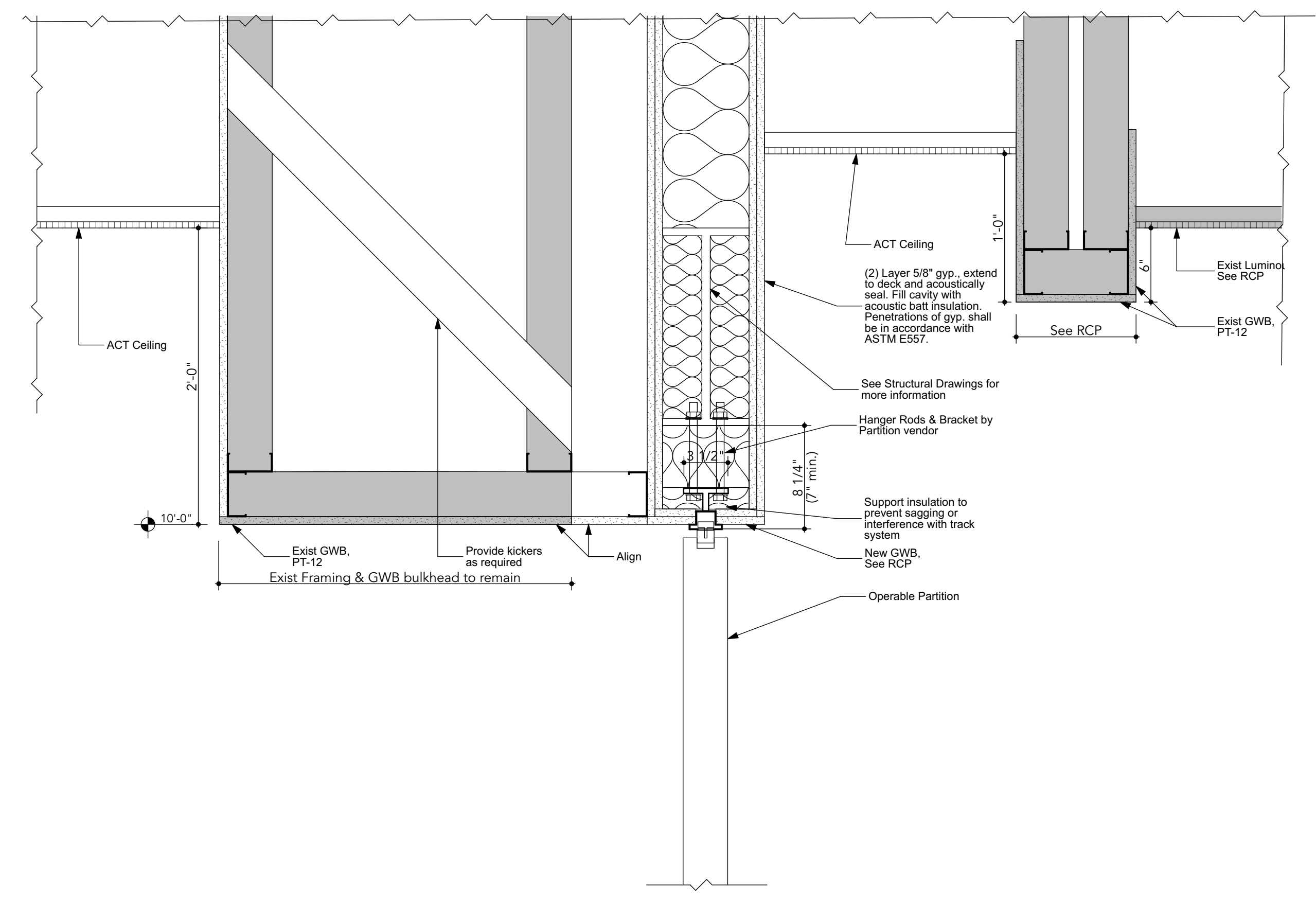
Ceiling Details



3 Rated Duct Shaft Detail
 A114 SCALE: 6" = 1'-0"



2 Section @ Egress Lobby Horizontal Duct Shaft
 A114 SCALE: 1/4" = 1'-0"



1 Operable Partition Section Detail
 A114 SCALE: 1 1/2" = 1'-0"

9825 - BIMcloud: Intersect A114 Framework: Sewer - BIMcloud: Intersect A114 Framework: Sewer - BIMcloud: Intersect A114 Framework: Sewer - BIMcloud: Intersect A114 Framework: Sewer

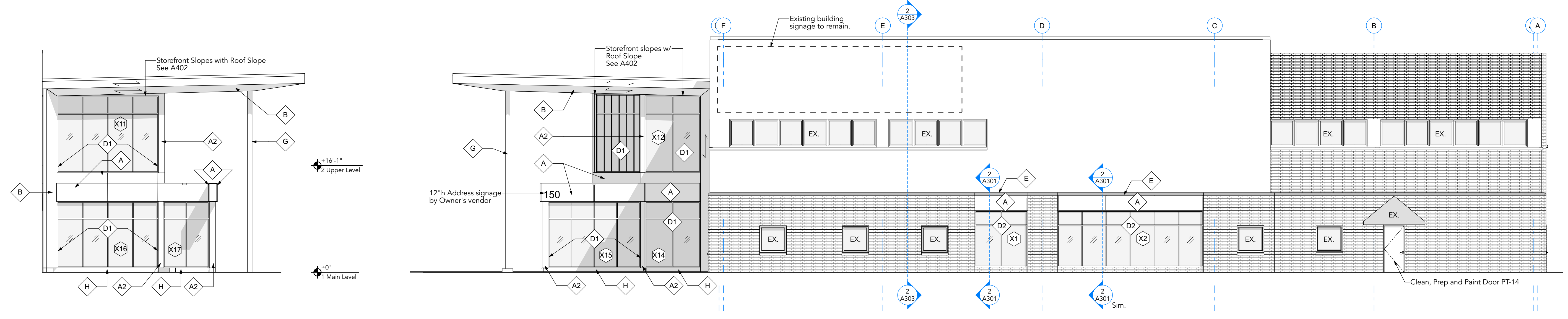
NOT FOR
 REGULATORY
 APPROVAL,
 PERMITTING, OR
 CONSTRUCTION

Bid Set 08/21/2025
 Site Plan Review 07/31/2025
 DD Set 07/03/2025
 © 2025, intersect studio, llc
 Project Number: 23-046

Exterior
 Elevations

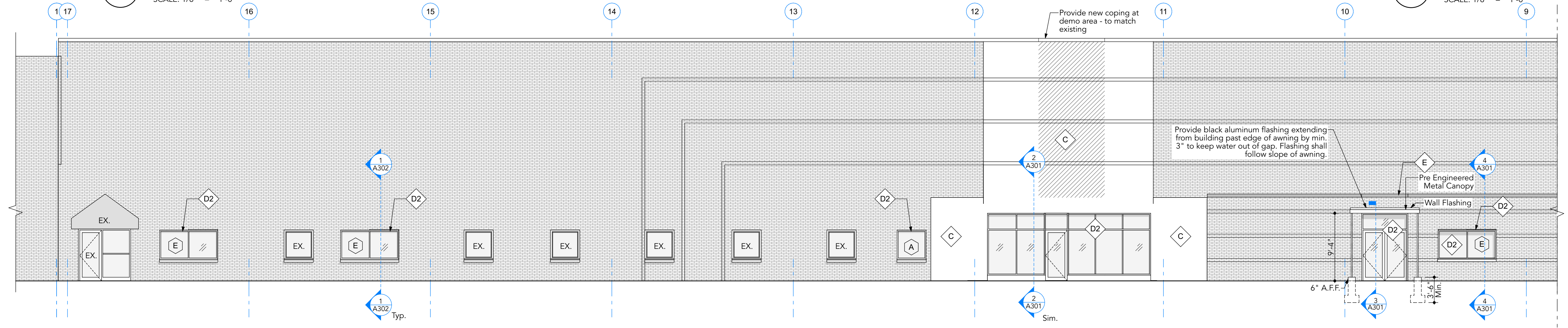
A201

EXTERIOR MATERIALS LEGEND					
A	Cut in Field Metal Panel System Basis of Design: Citadel Panel 20 Color: Mansard Brown	D1	4 1/2" Aluminum Storefront System Basis of Design: Tubelite T14000 Color: Champagne Anodize	G	Galvanized Steel Columns - prime & paint PT-14.
A2	Cut in Field Metal Panel System Basis of Design: Citadel Panel 20 Color: Champagne Anodized	D2	4 1/2" Aluminum Storefront System Basis of Design: Tubelite T14000 Color: Dark Bronze Anodize	H	Concrete Sill
B	Tongue & groove 'Wood-Look' aluminum soffit plank system. Basis of Design: Longboard Finish: Light Bamboo	E	Existing Copper Flashing to remain.		
C	Patch & repair PE EIFS system after demolition to match existing. Paint all remaining EIFS PT-13. Provide test swatch in field.	F	Tooth in brick from existing brick salvaged during demo, include light brick bands		

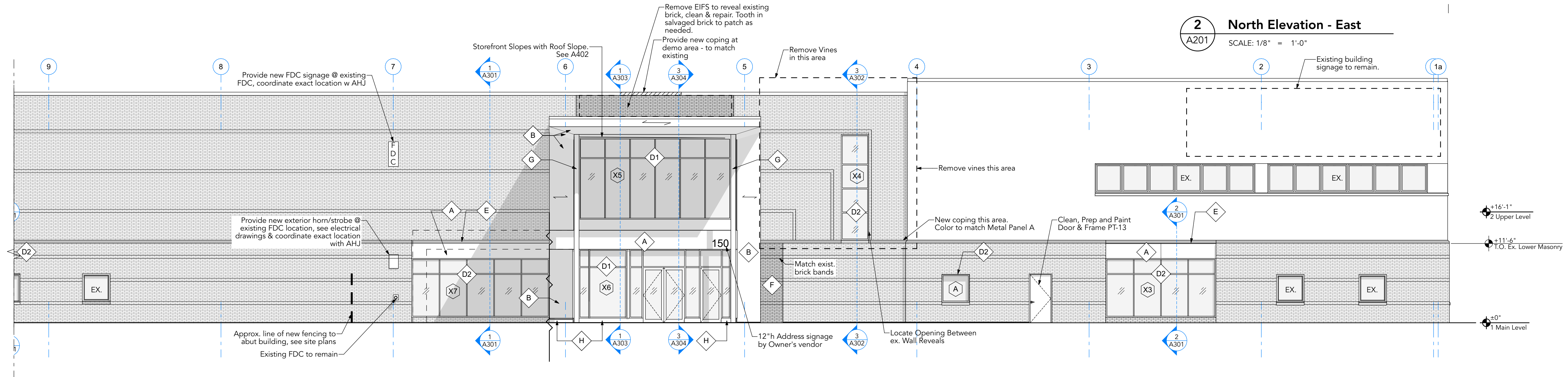


4 Entry - East Elevation
 A201 SCALE: 1/8" = 1'-0"

3 WEST Elevation
 A201 SCALE: 1/8" = 1'-0"



2 North Elevation - East
 A201 SCALE: 1/8" = 1'-0"

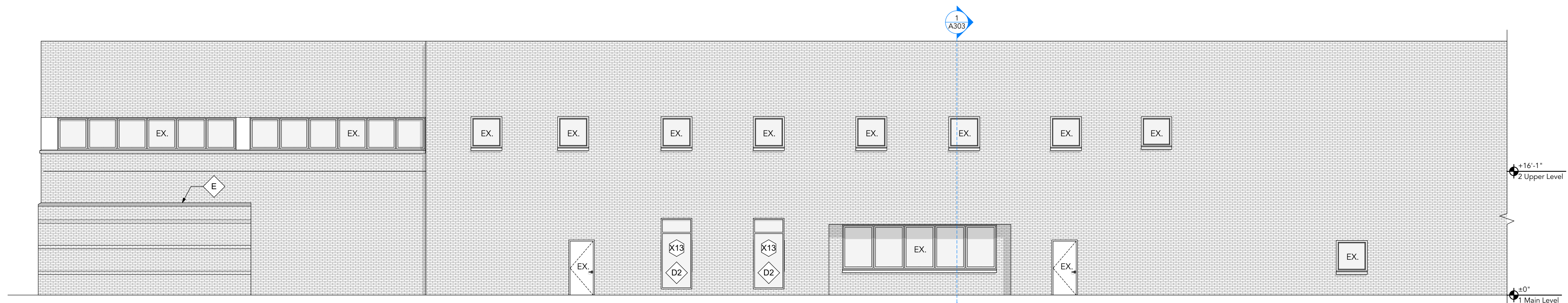


1 North Elevation - West
 A201 SCALE: 1/8" = 1'-0"

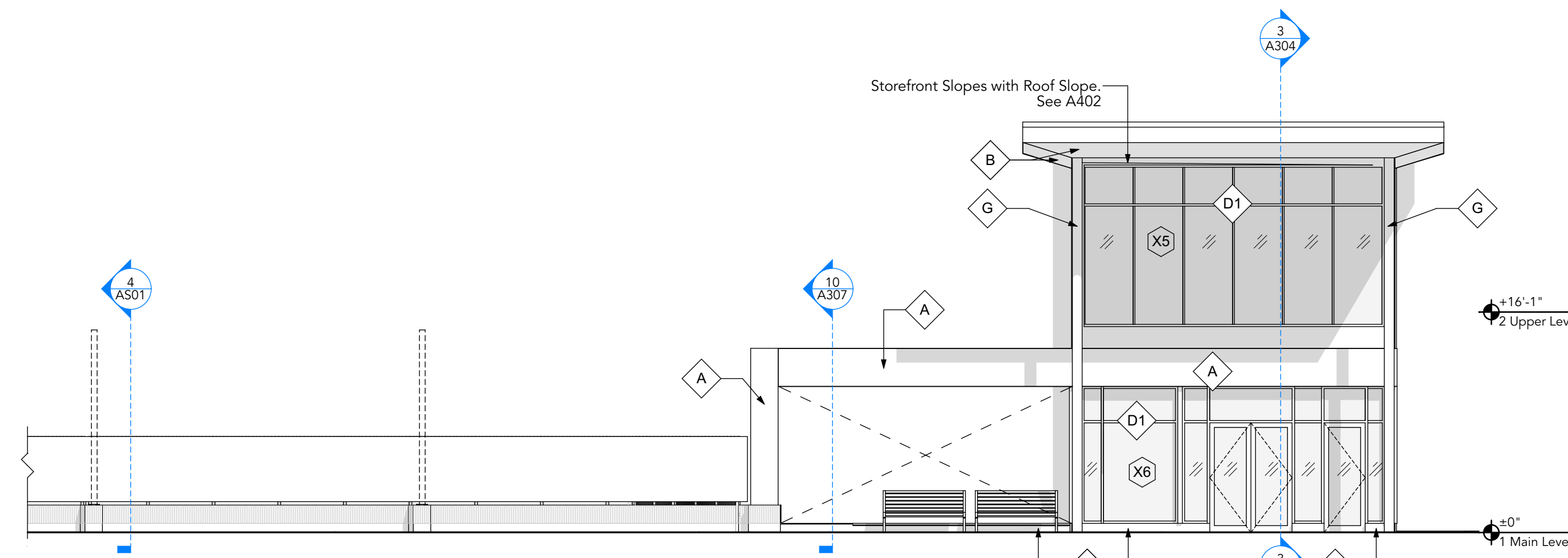
8/6/25 - BIMcloud: Intersect A201 Framework Server - BIMcloud: Intersect A201 Framework Server - BIMcloud: Intersect A201 Framework Server - BIMcloud: Intersect A201 Framework Server - BIMcloud: Intersect A201 Framework Server

EXTERIOR MATERIALS LEGEND

A	Cut in Field Metal Panel System Basis of Design: Citadel Panel 20 Color: Mansard Brown	D1	4 1/2" Aluminum Storefront System Basis of Design: Tubelite T14000 Color: Champagne Anodize	G	Galvanized Steel Columns - prime & paint PT-14.
A2	Cut in Field Metal Panel System Basis of Design: Citadel Panel 20 Color: Champagne Anodized	D2	4 1/2" Aluminum Storefront System Basis of Design: Tubelite T14000 Color: Dark Bronze Anodize	H	Concrete Sill
B	Tongue & groove 'Wood-Look' aluminum soffit plank system. Basis of Design: Longboard Finish: Light Bamboo	E	Existing Copper Flashing to remain.		
C	Patch & repair PE EIFS system after demolition to match existing. Paint all remaining EIFS PT-13. Provide test swatch in field.	F	Tooth in brick from existing brick salvaged during demo, include light brick bands		



2 South Elevation - West
A202 SCALE: 1/8" = 1'-0"



1 Entry - North Elevation
A202 SCALE: 1/8" = 1'-0"

94925 - BIMcloud: Intersect A202 Framework: Sever - BIMcloud: Intersect A202 Framework: Sever - BIMcloud: Intersect A202 Framework: Sever - BIMcloud: Intersect A202 Framework: Sever - BIMcloud: Intersect A202 Framework: Sever

NOT FOR
REGULATORY
APPROVAL,
PERMITTING, OR
CONSTRUCTION

Bid Set 08/21/2025
Site Plan Review 07/31/2025
DD Set 07/03/2025
© 2025, intersect studio, llc
Project Number: 23-046

Exterior
Elevations

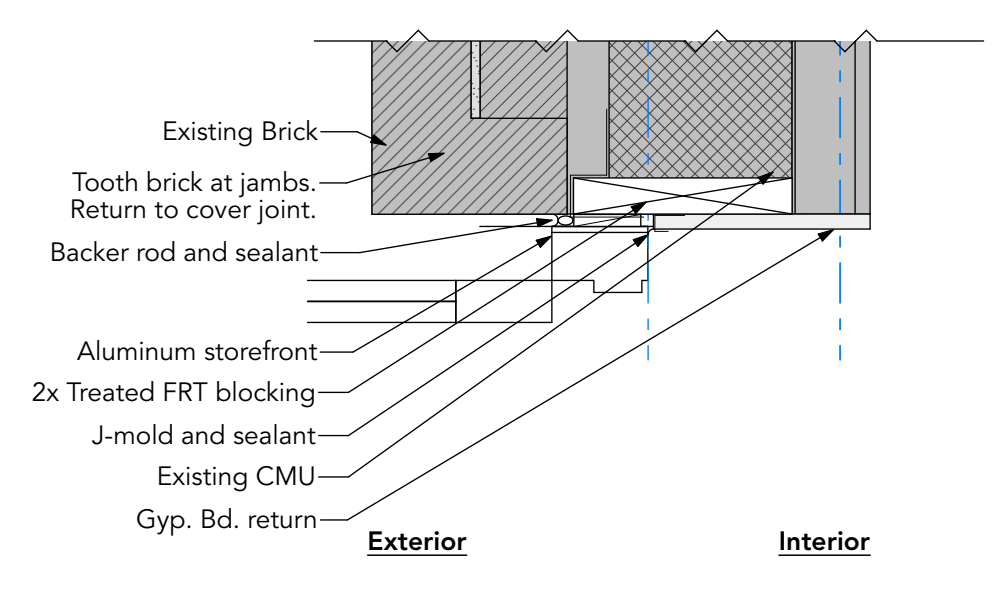
A202

NOT FOR
 REGULATORY
 APPROVAL,
 PERMITTING, OR
 CONSTRUCTION

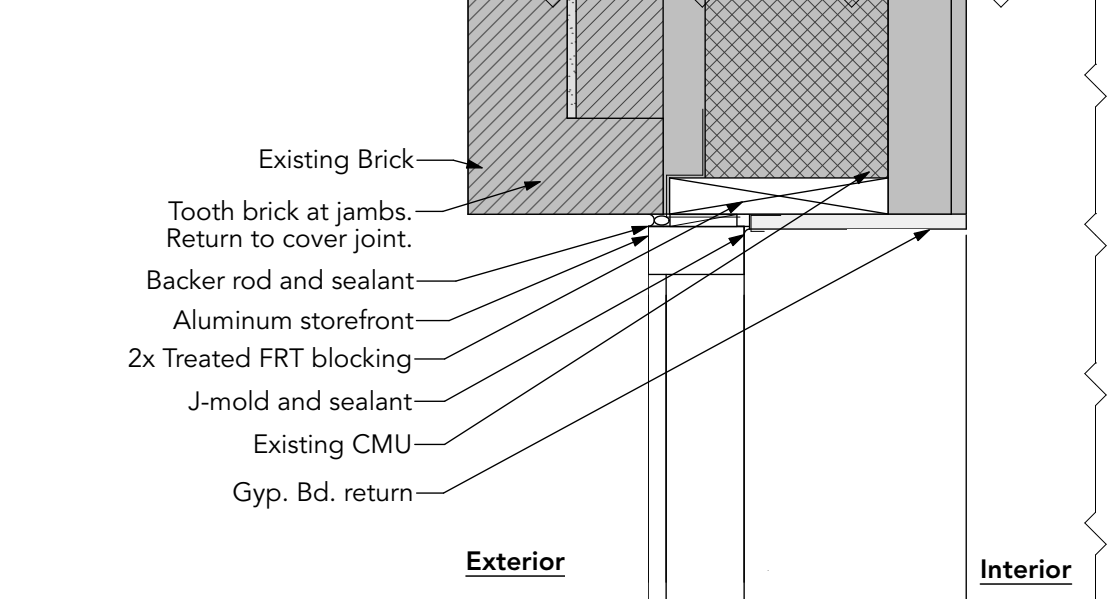
Bid Set 08/21/2025
 Site Plan Review 07/31/2025
 DD Set 07/03/2025
 © 2025, intersect studio, llc
 Project Number: 23-046

Exterior Wall
 Sections

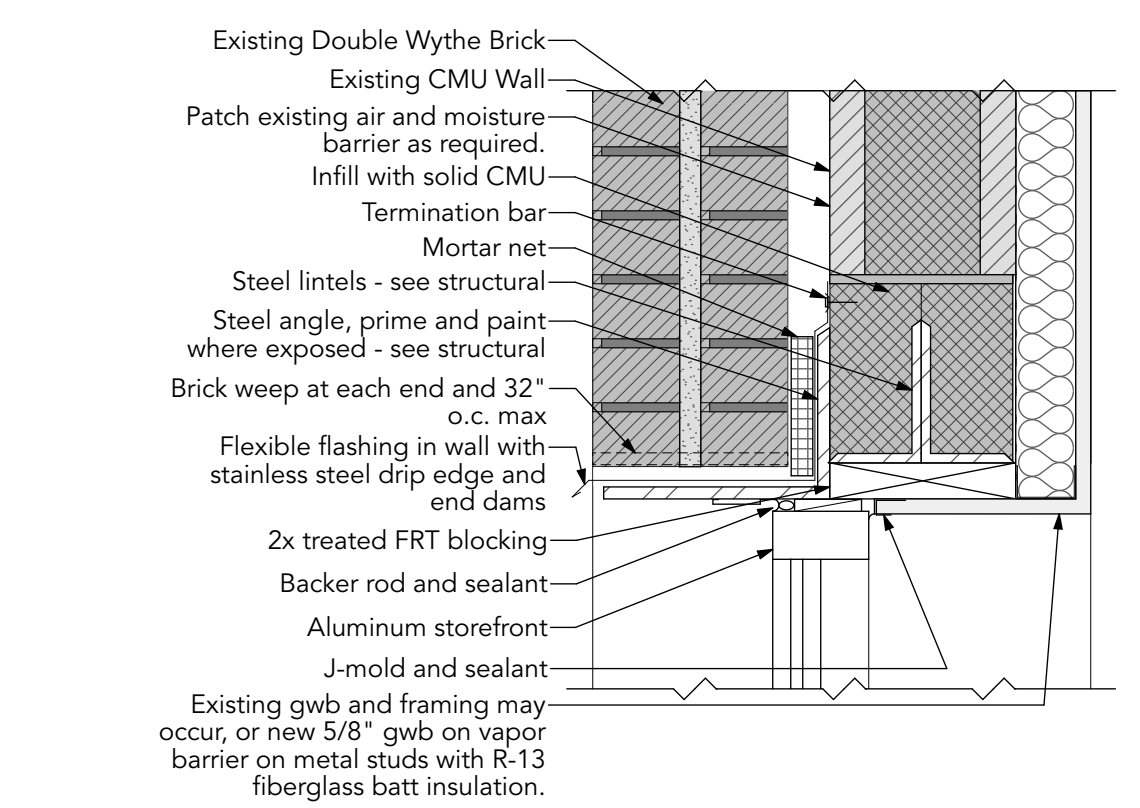
A301



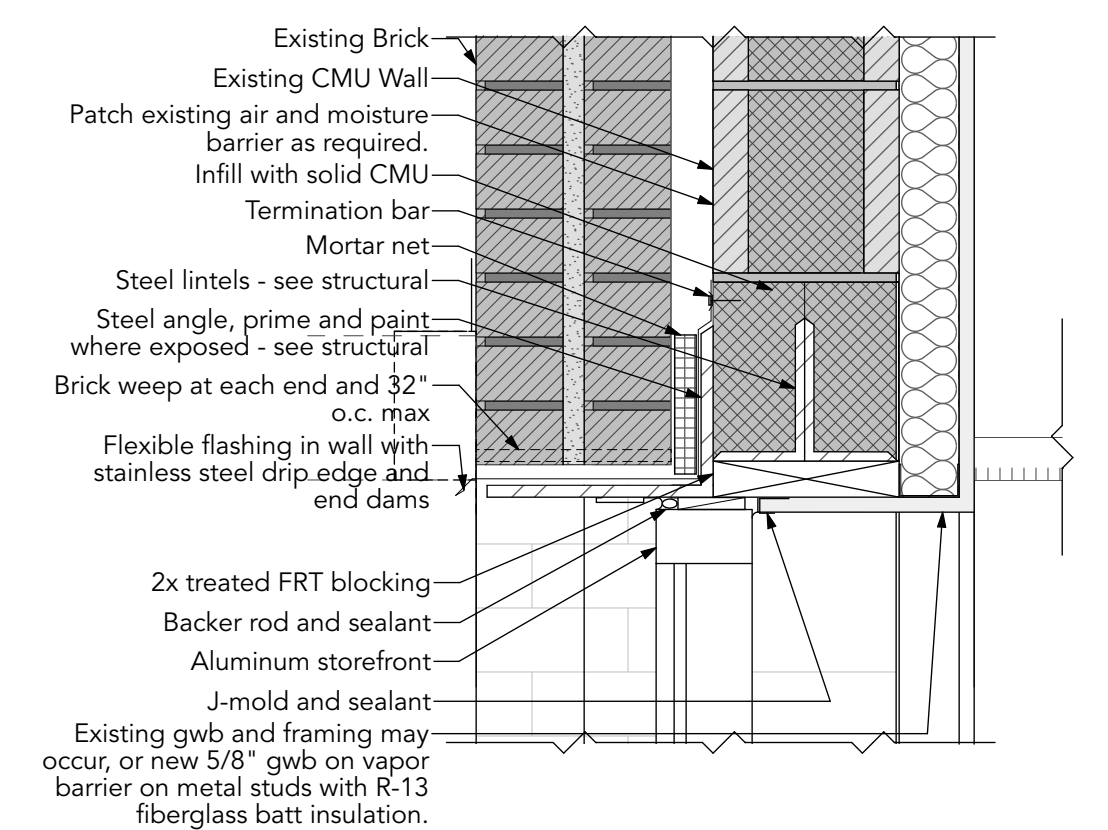
13 Aluminum SF Door Jamb
 A301 SCALE: 1 1/2" = 1'-0"



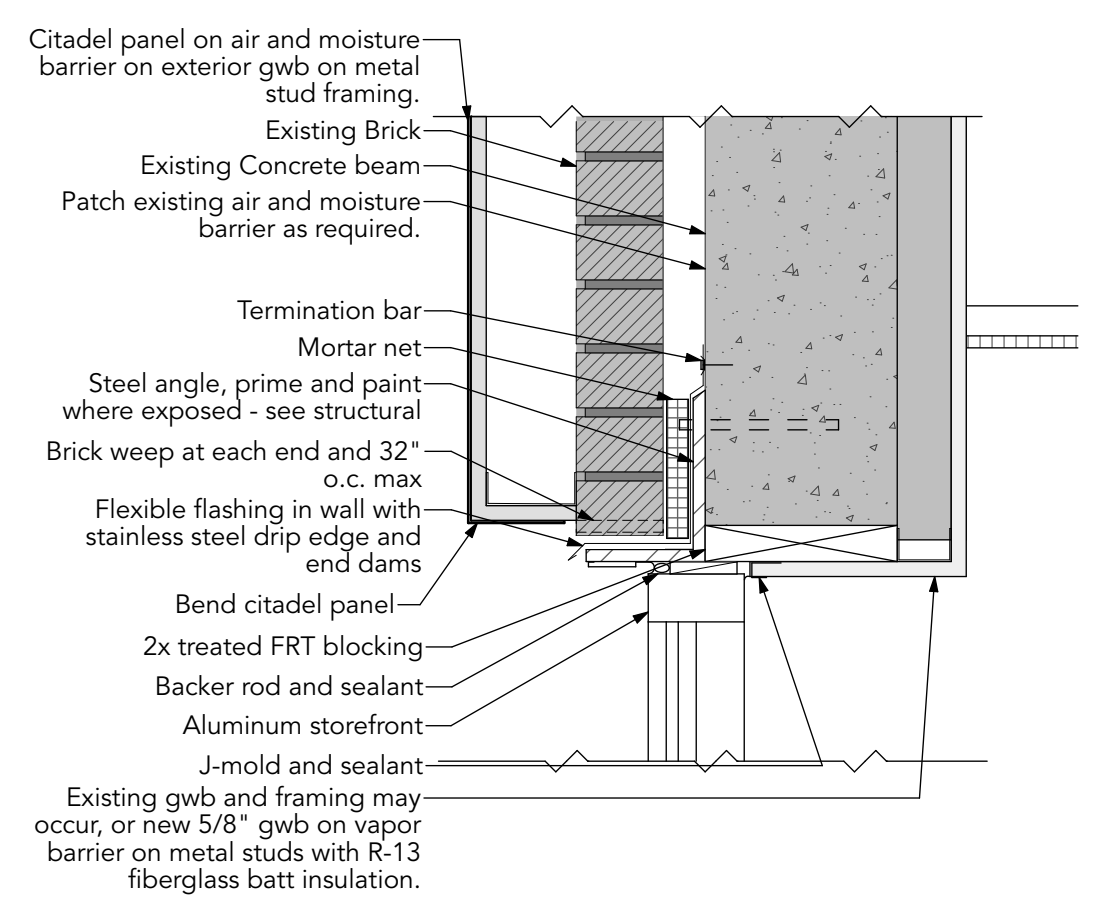
12 Aluminum SF Jamb at Double Wythe Brick
 A301 SCALE: 1 1/2" = 1'-0"



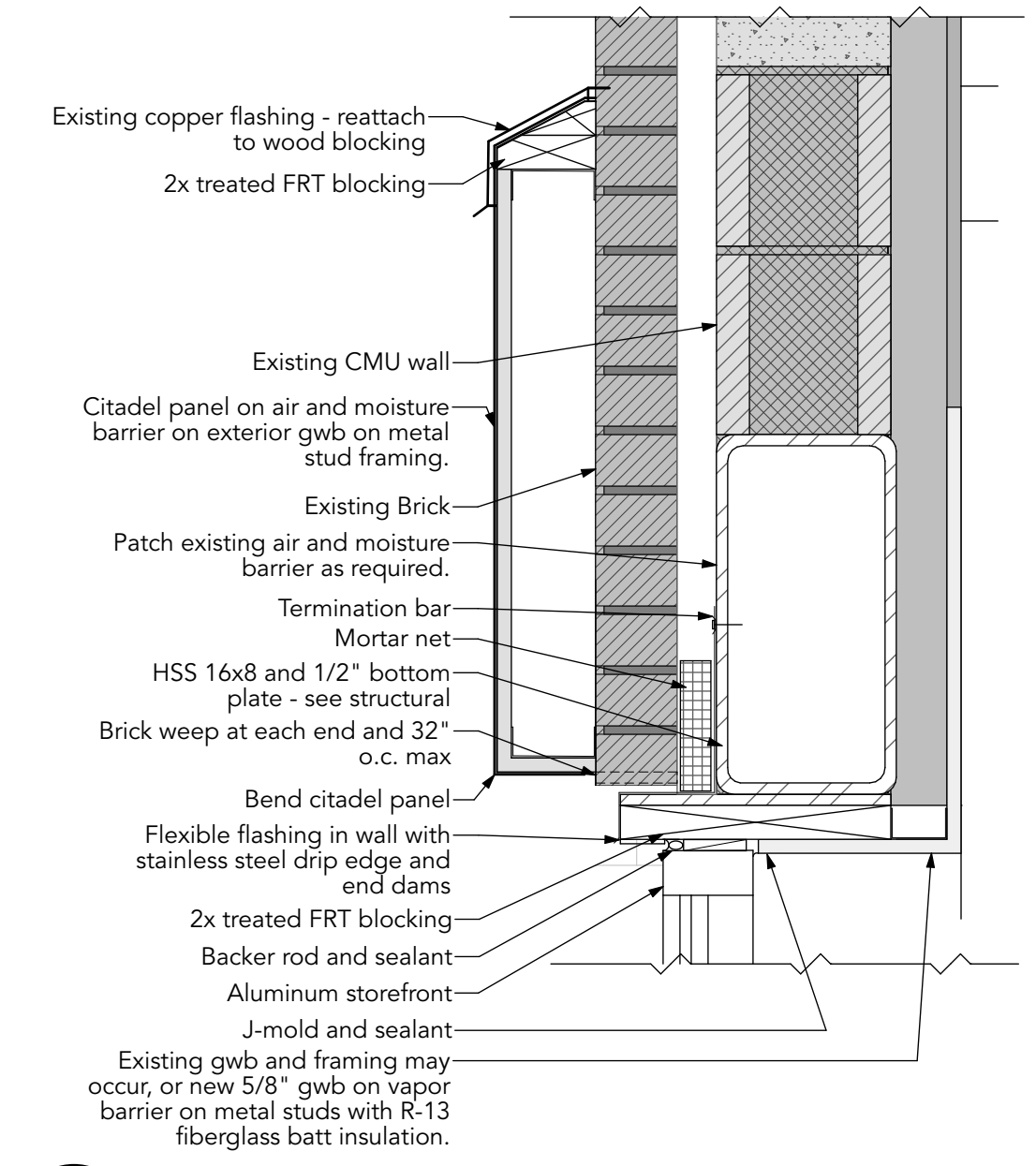
11 FG Fixed Window Head at Double Wythe Brick
 A301 SCALE: 1 1/2" = 1'-0"



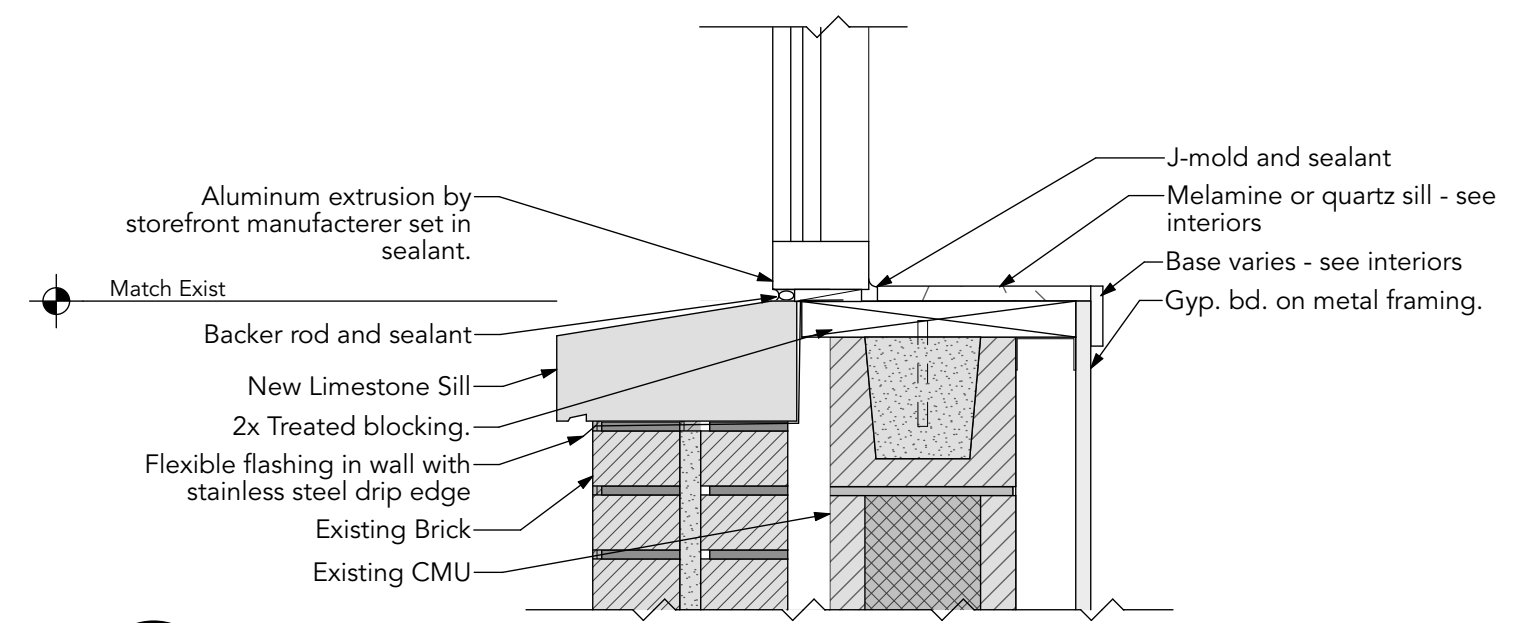
10 Aluminum SF Trans Head
 A301 SCALE: 1 1/2" = 1'-0"



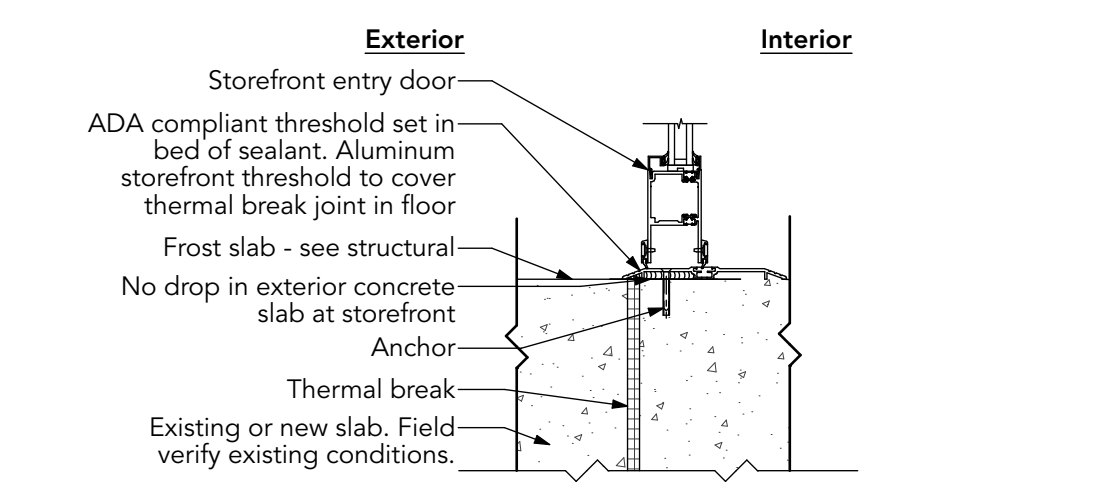
9 Aluminum SF Head at Concrete
 A301 SCALE: 1 1/2" = 1'-0"



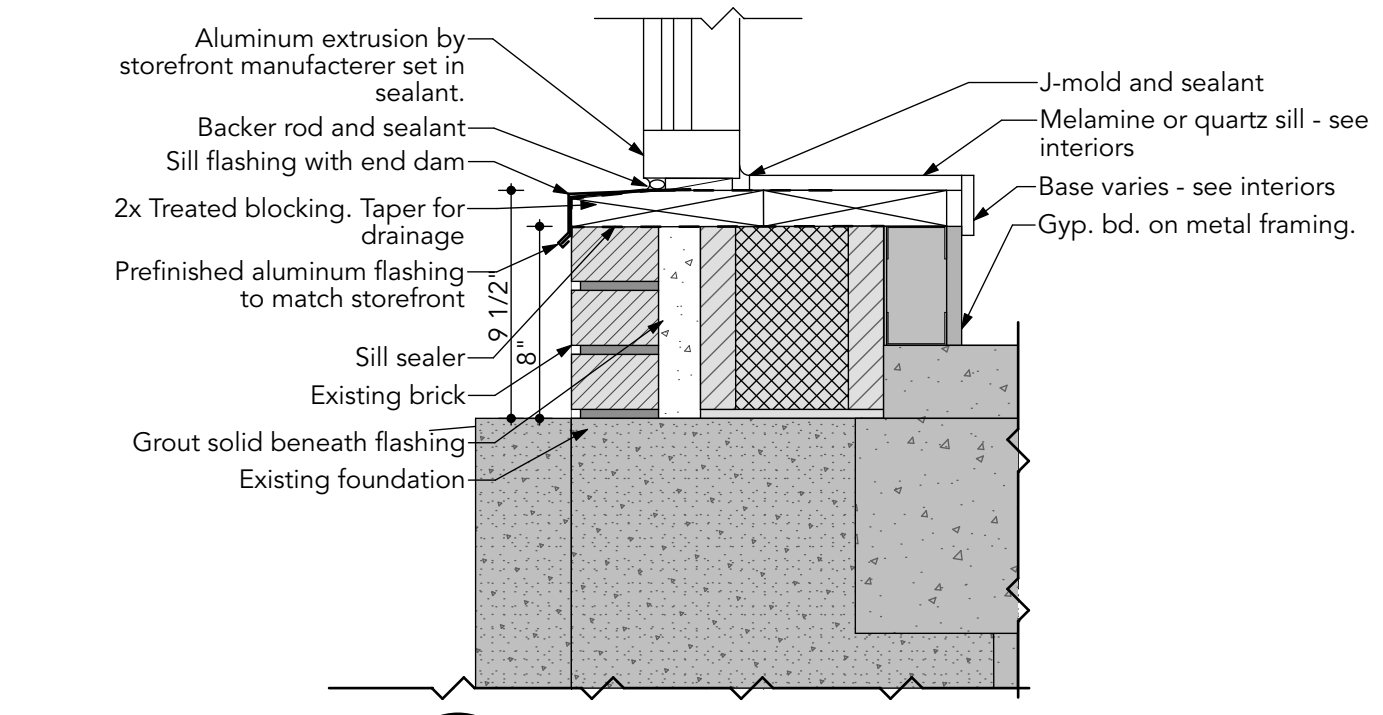
5 Aluminum SF Head at CMU
 A301 SCALE: 1 1/2" = 1'-0"



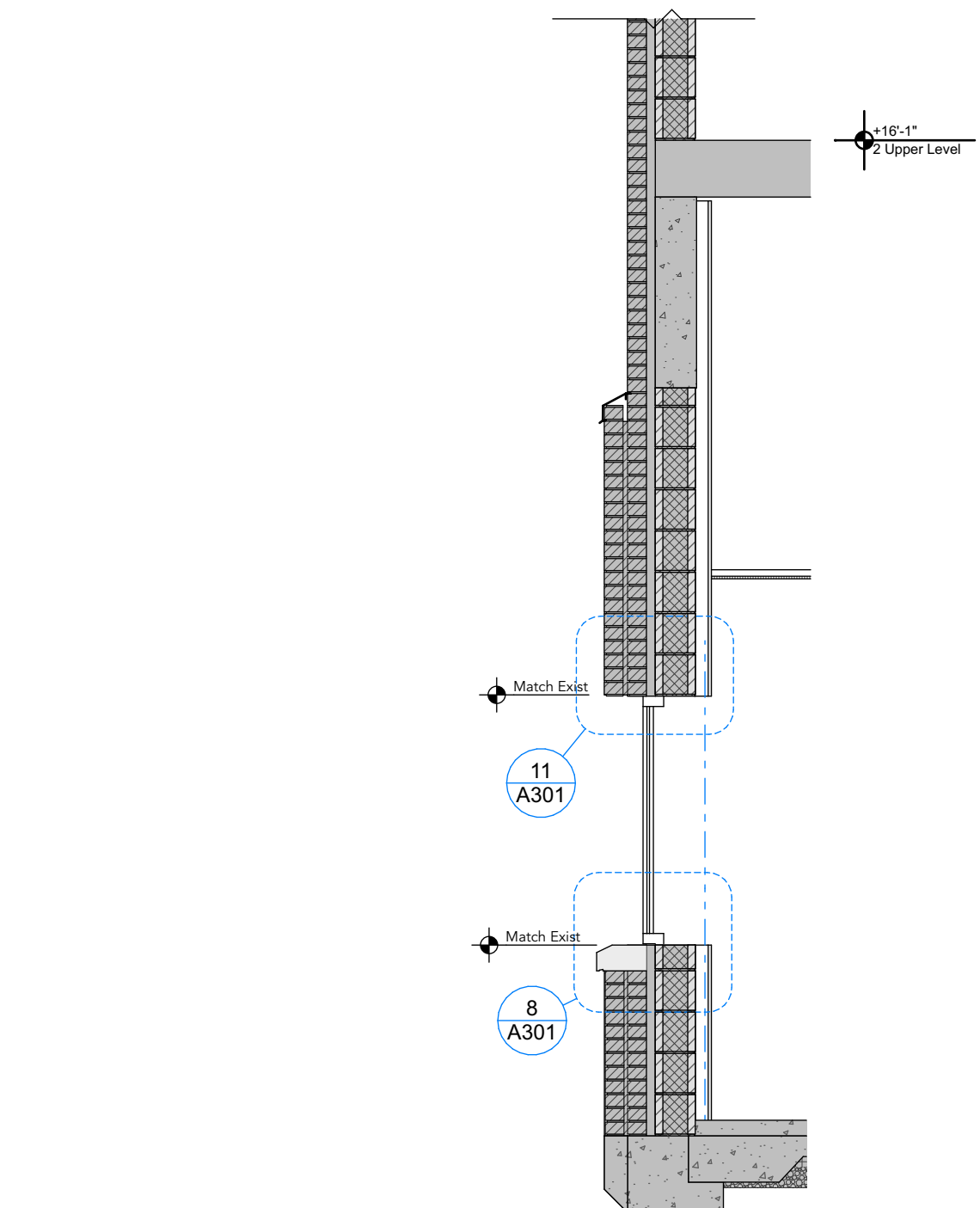
8 FG Fixed Window Sill at Double Wythe Brick
 A301 SCALE: 1 1/2" = 1'-0"



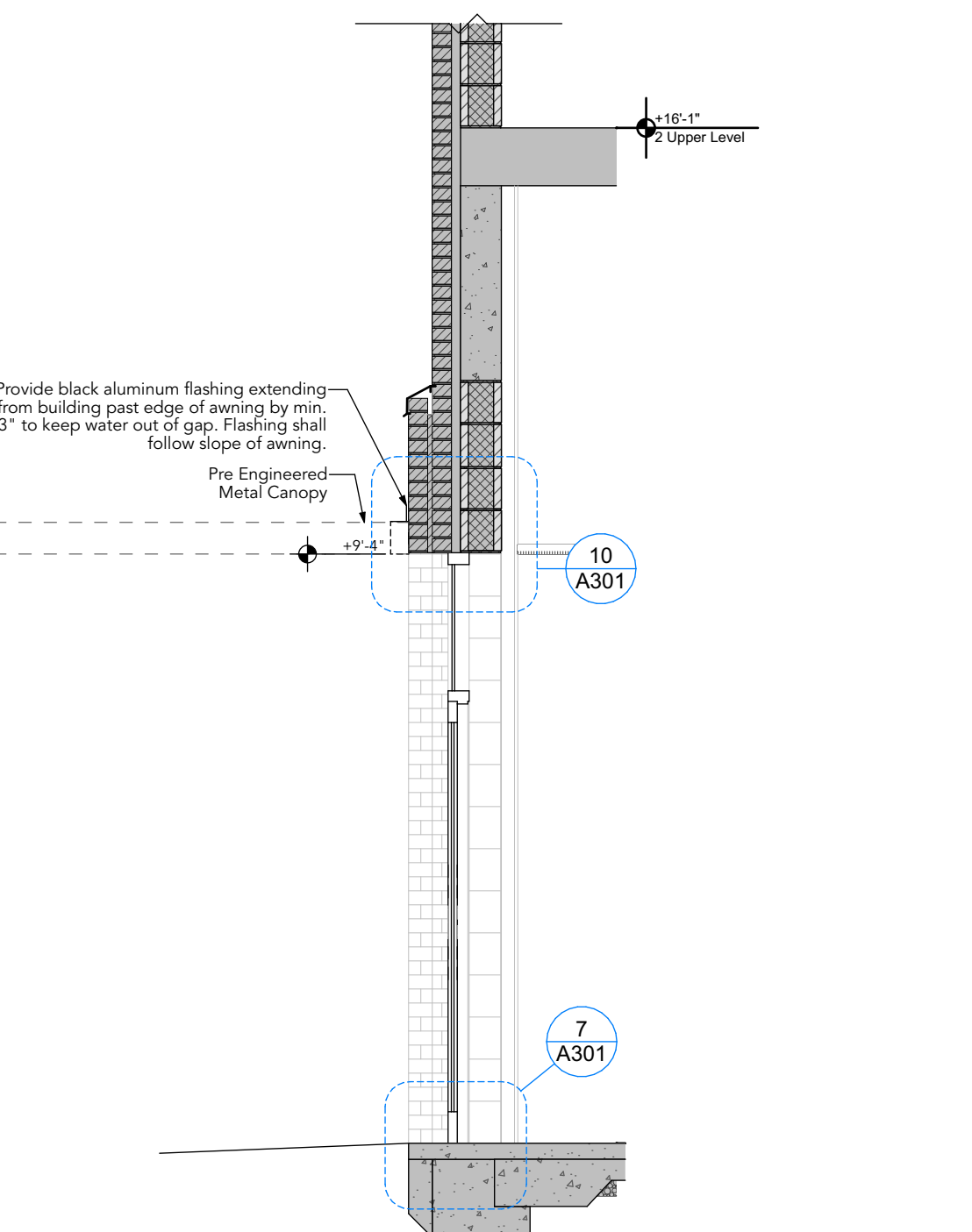
7 Aluminum SF Door Threshold
 A301 SCALE: 1 1/2" = 1'-0"



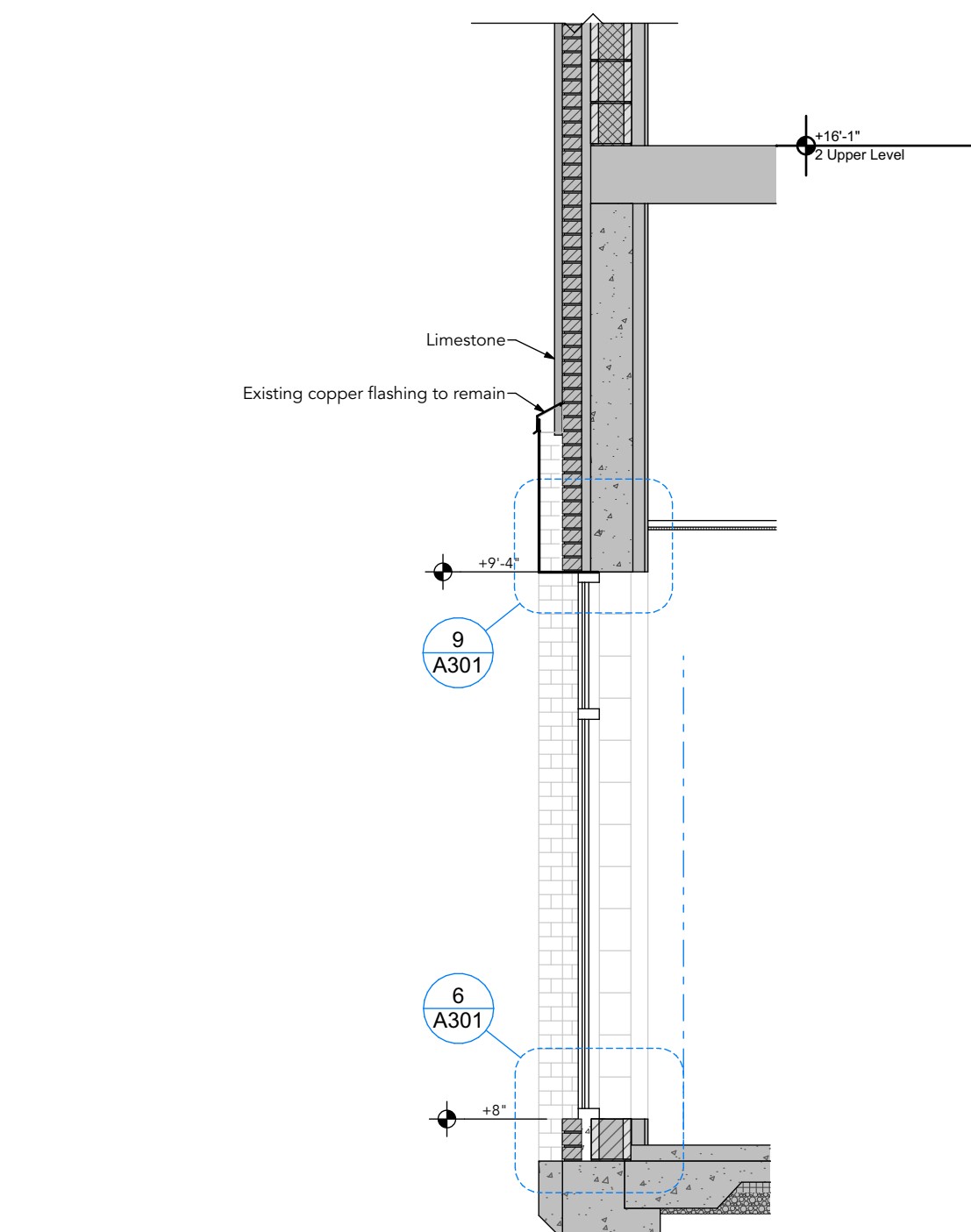
6 Aluminum SF Sill at Floor
 A301 SCALE: 1 1/2" = 1'-0"



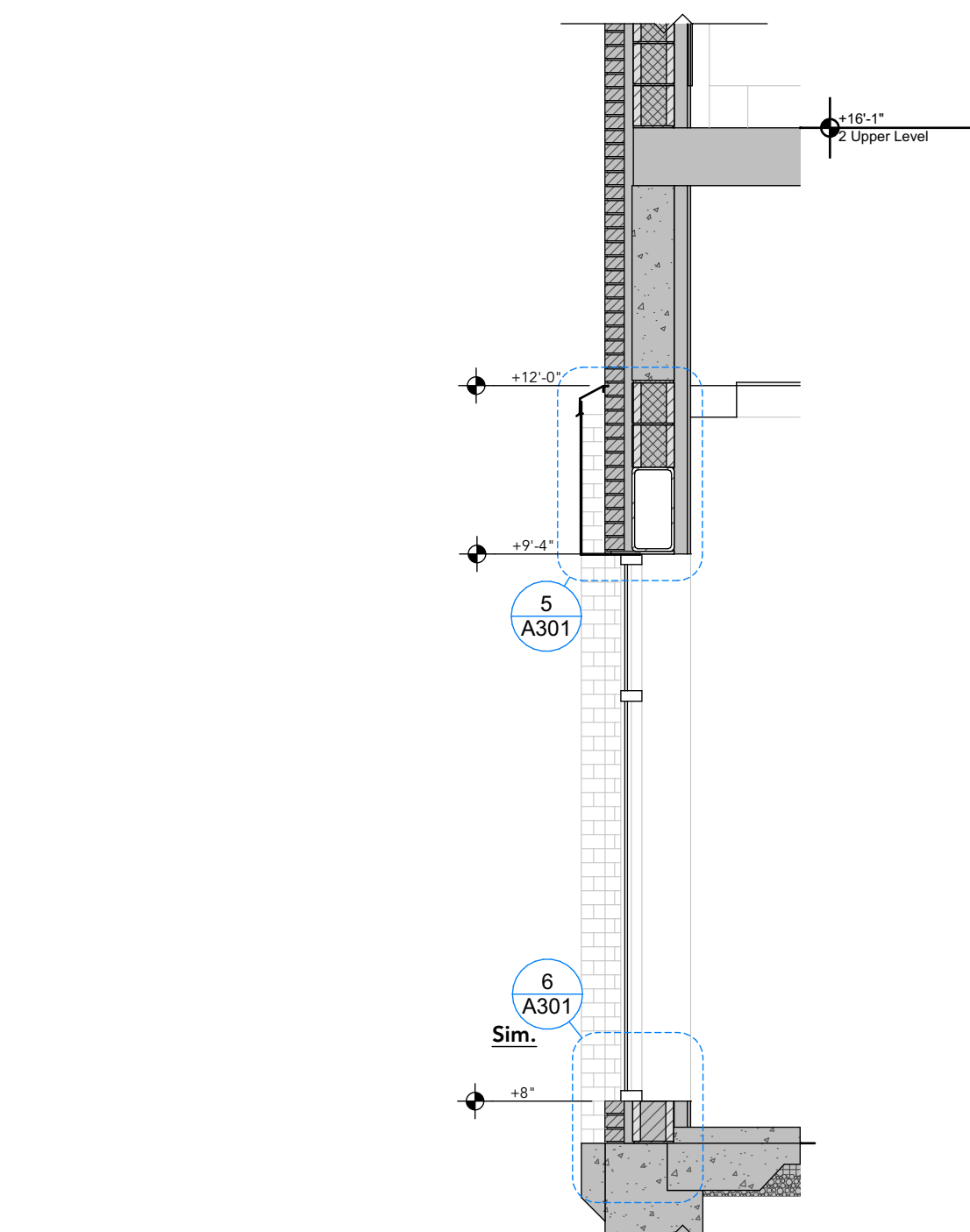
4 Punched Window @ Double Wythe Brick
 A301 SCALE: 3/8" = 1'-0"



3 Storefront Door @ Awning & Metal Panel
 A301 SCALE: 3/8" = 1'-0"

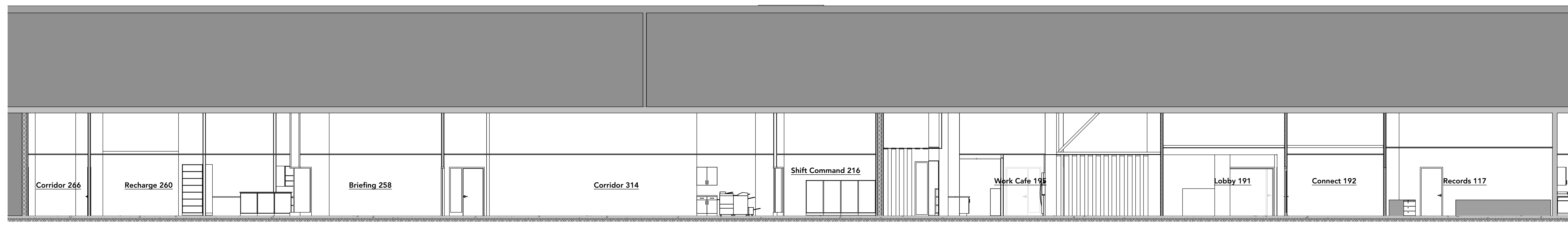


2 Storefront @ Concrete Header & Metal Panel
 A301 SCALE: 3/8" = 1'-0"



1 Storefront @ CMU Header & Metal Panel
 A301 SCALE: 3/8" = 1'-0"

BIDDING: Bidding: Intersect A301 Framework: Sewer - BIMcloud Bluelic for Archival 27252646 Koro Crosstown Facility



3 East-West Section B
 A303 SCALE: 1/8" = 1'-0"



2 East-West Section A
 A303 SCALE: 1/8" = 1'-0"



1 North-South Building Section
 A303 SCALE: 1/8" = 1'-0"

City of Kalamazoo - Crosstown Facility
 CPED & KDPS Workplace Renovation
 150 E Crosstown Parkway Kalamazoo MI 49001

NOT FOR
 REGULATORY
 APPROVAL,
 PERMITTING, OR
 CONSTRUCTION

Bid Set 08/21/2025
 Site Plan Review 07/31/2025
 DD Set 07/03/2025
 © 2025, intersect studio, llc
 Project Number: 23-046

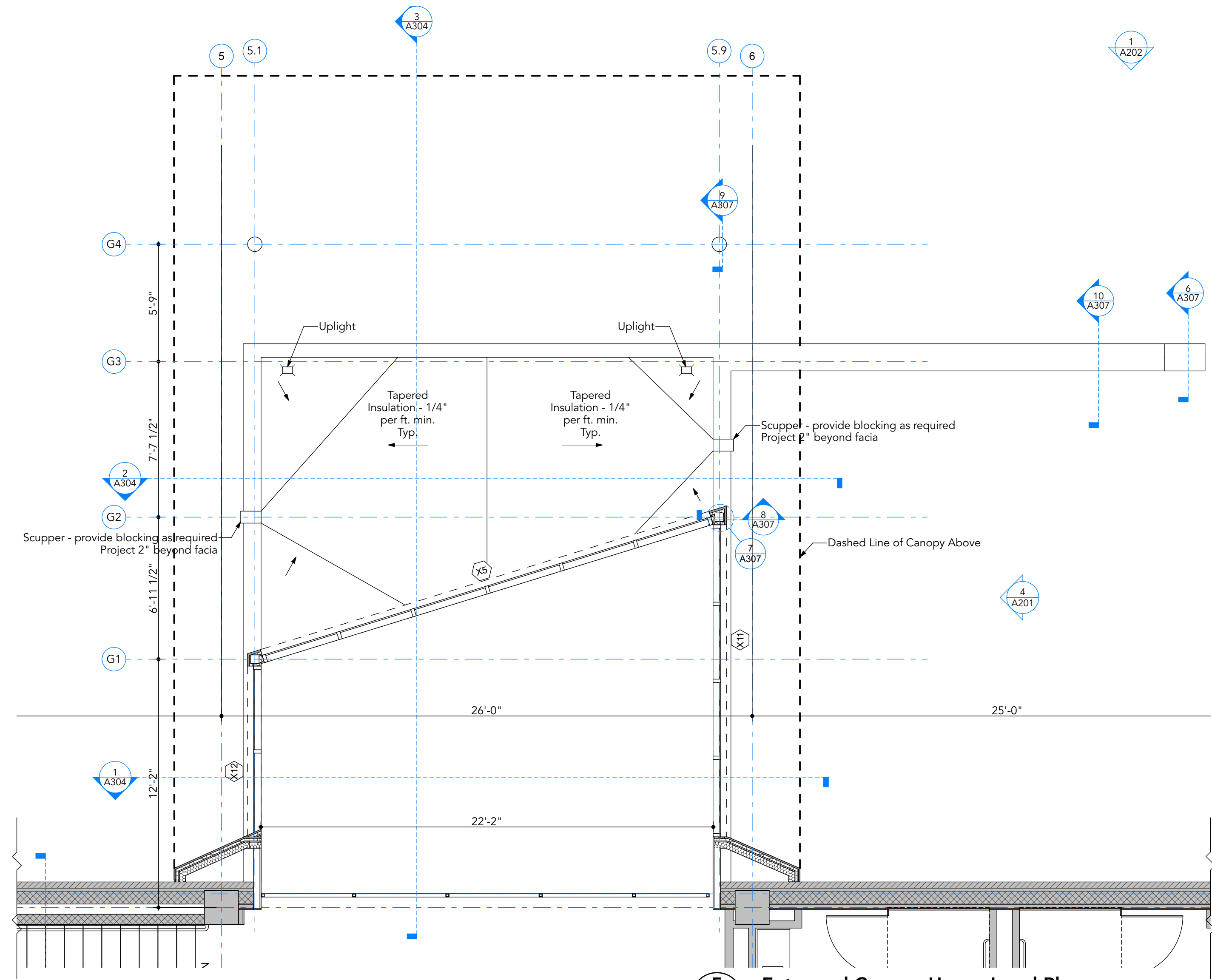
Building Sections

A303

8/6/25 - BIMcloud: Intersect A303 Framework: Server - BIMcloud: Intersect A303 Framework: Client - BIMcloud: Intersect A303 Framework: Client - BIMcloud: Intersect A303 Framework: Client

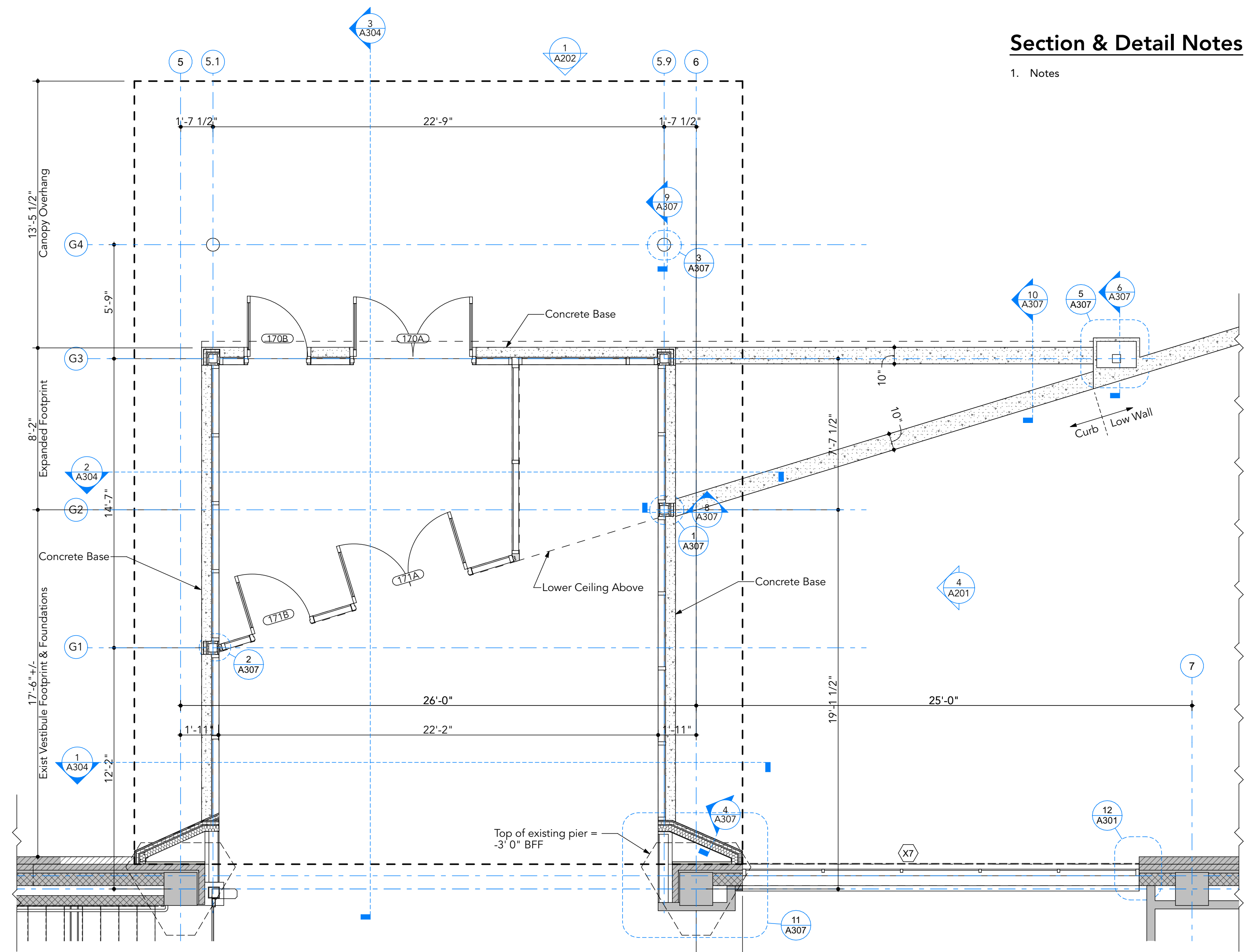
Section & Detail Notes

1. Notes



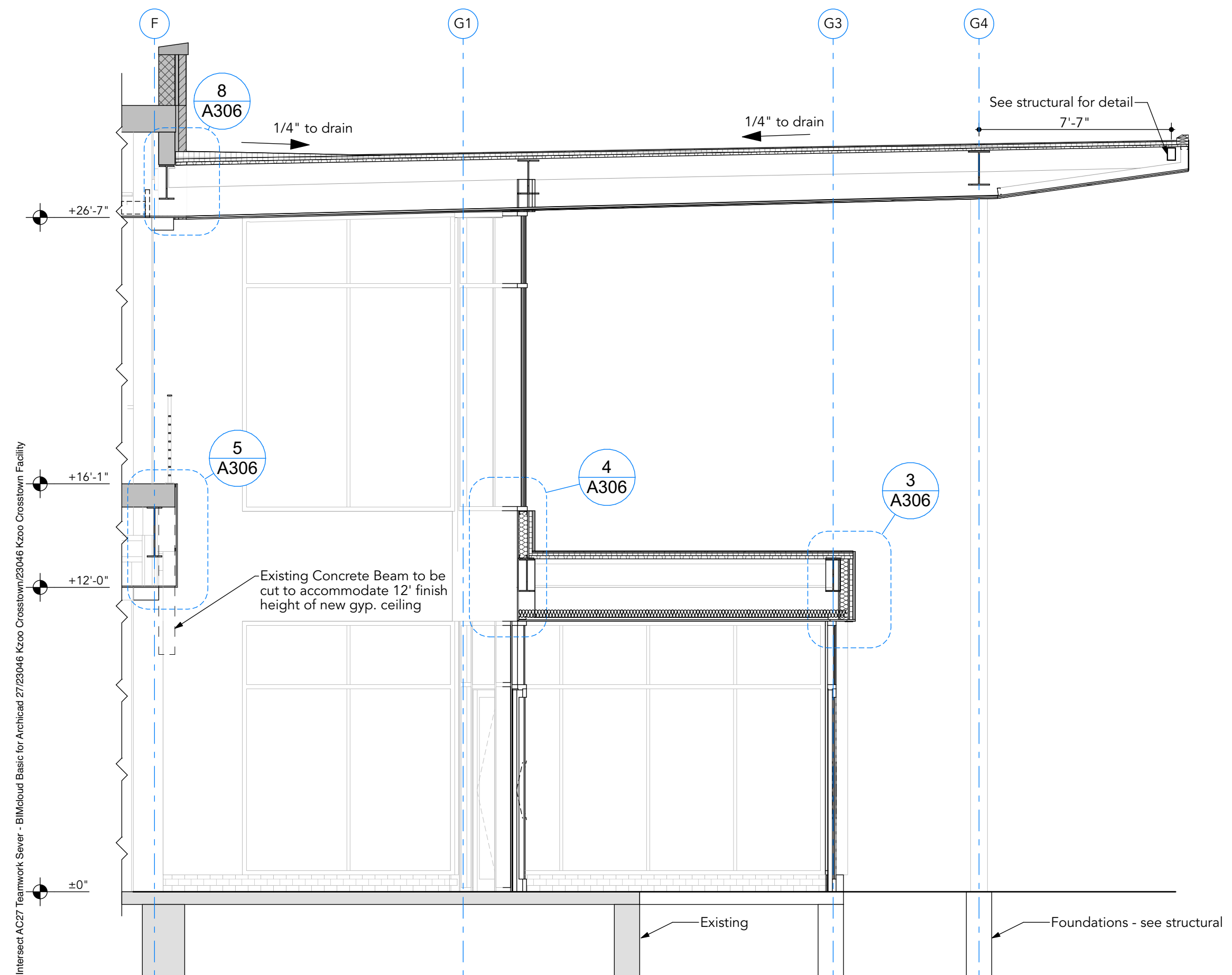
5 Entry and Canopy Upper Level Plan

SCALE: 1/4" = 1'-0"



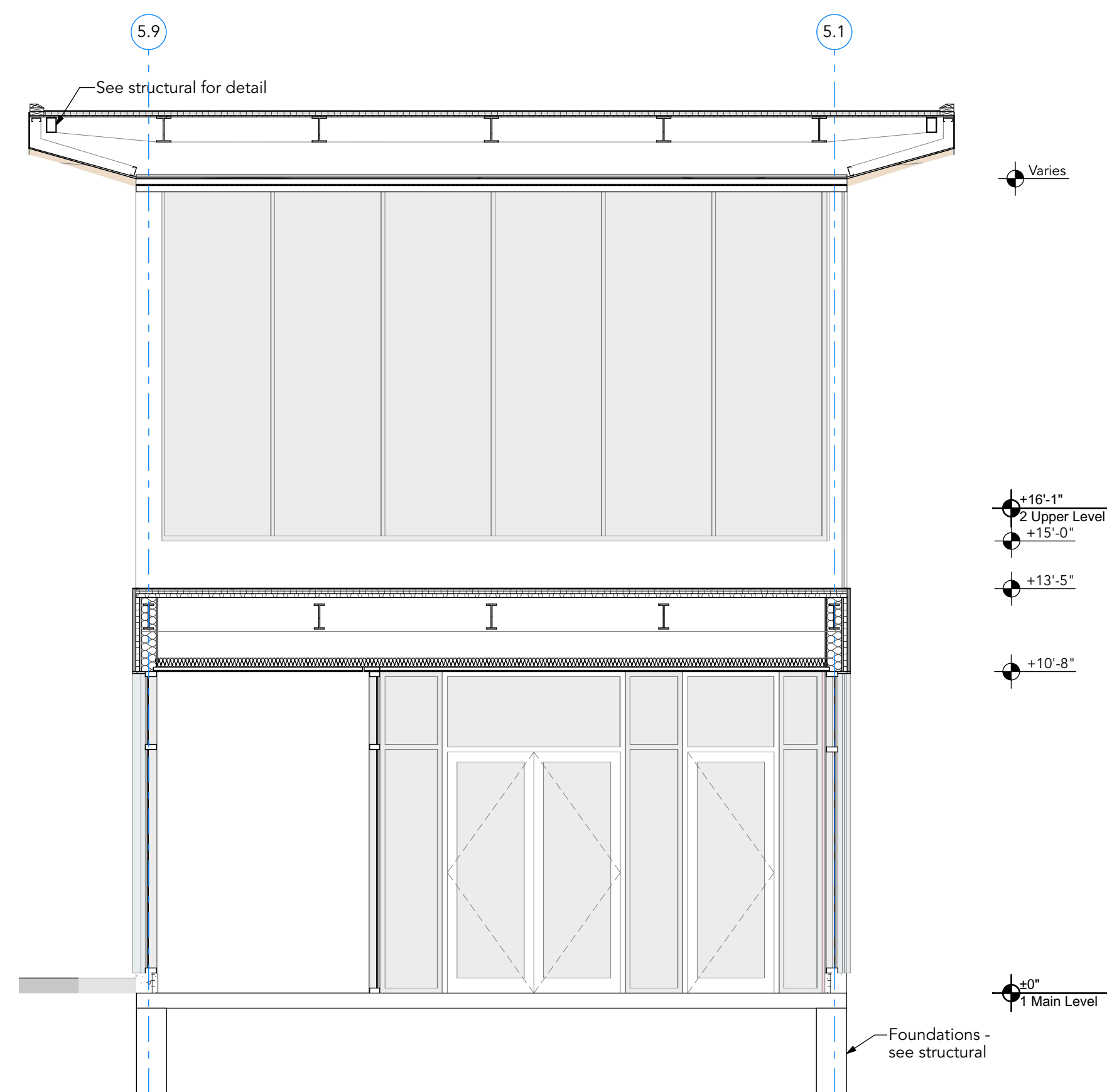
6 Entry and Canopy Plan

SCALE: 1/4" = 1'-0"



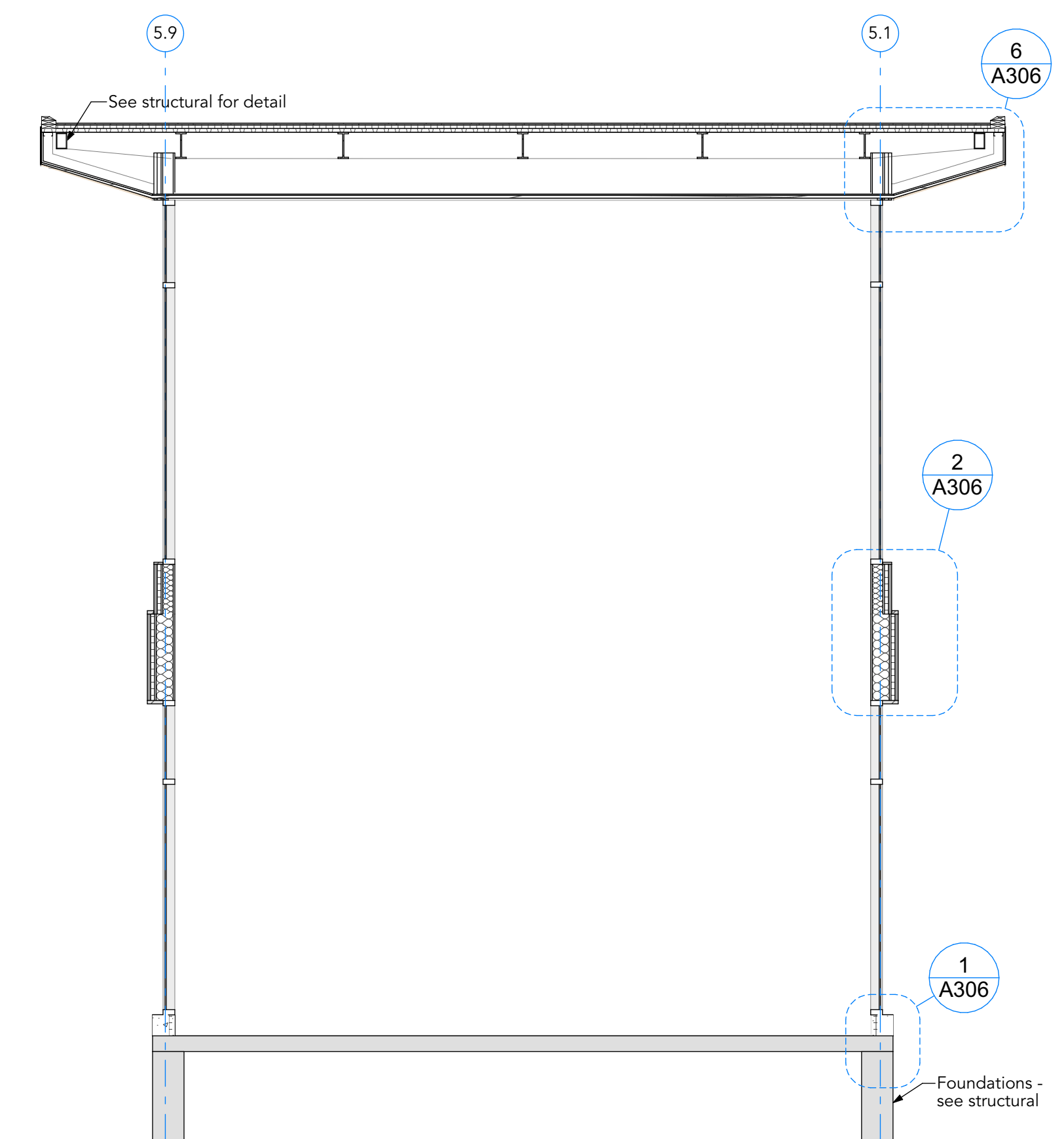
3 Canopy Section - Transverse

SCALE: 1/4" = 1'-0"



2 Building Section

SCALE: 1/4" = 1'-0"



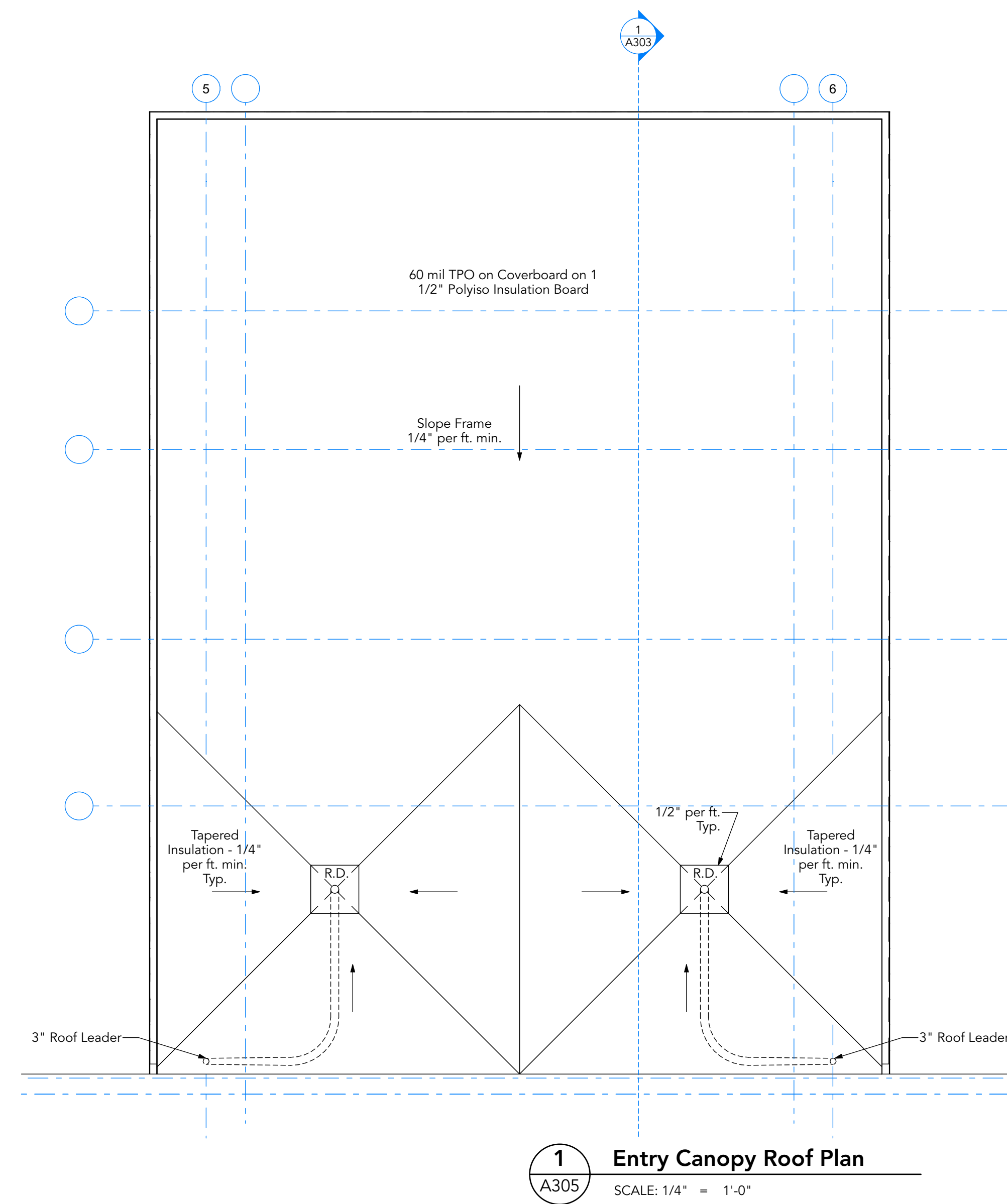
1 Building Section

SCALE: 1/4" = 1'-0"

NOT FOR REGULATORY APPROVAL, PERMITTING, OR CONSTRUCTION

Bid Set 08/21/2025
Site Plan Review 07/31/2025
DD Set 07/03/2025
© 2025, intersect studio, llc
Project Number: 23-046

Entry and Canopy



1
A305 **Entry Canopy Roof Plan**
SCALE: 1/4" = 1'-0"

NOT FOR
REGULATORY
APPROVAL,
PERMITTING, OR
CONSTRUCTION

Bid Set 08/21/2025
Site Plan Review 07/31/2025
DD Set 07/03/2025
© 2025, intersect studio, llc
Project Number: 23-046

**Entry Canopy
Roof Plan**

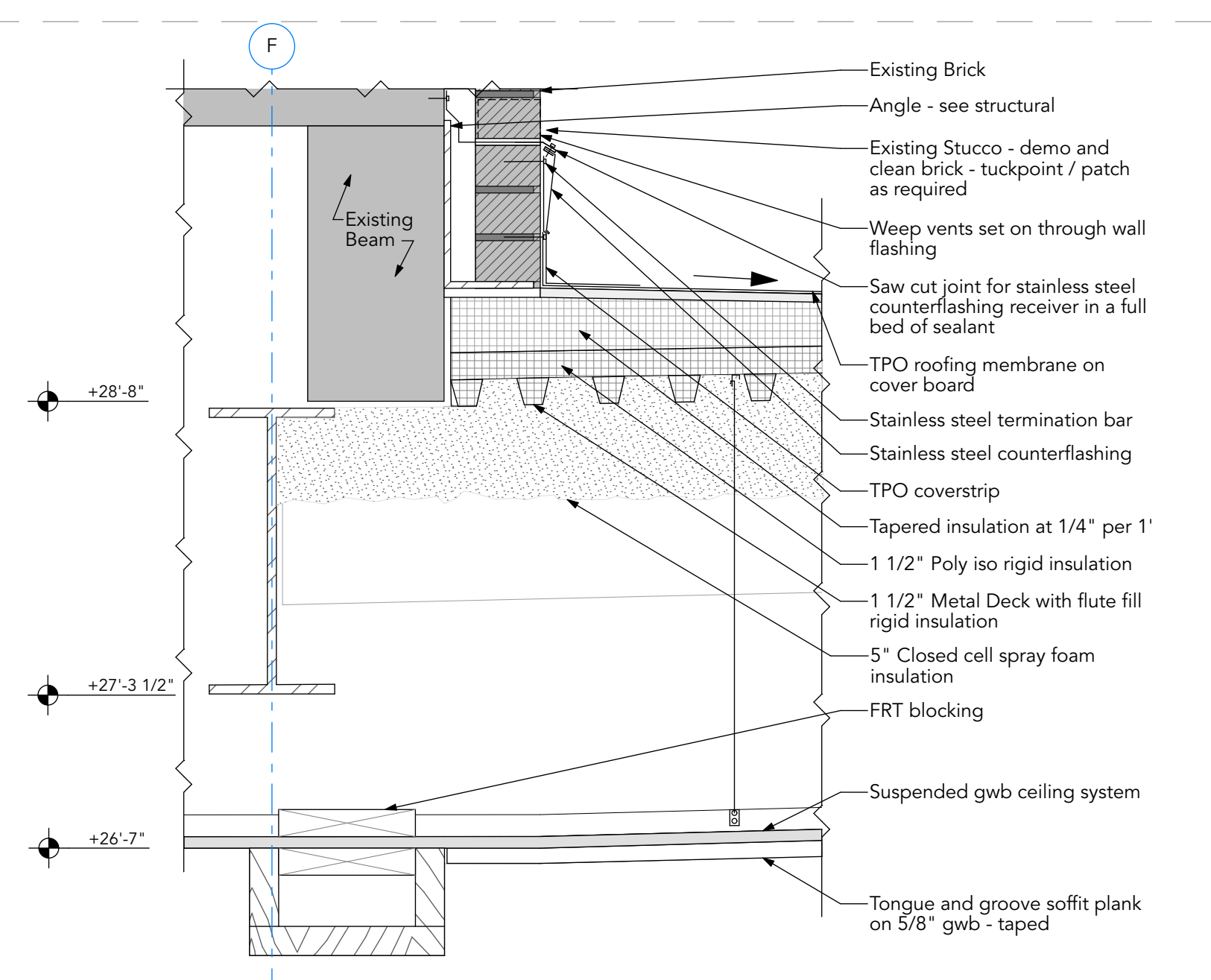
A305

NOT FOR
 REGULATORY
 APPROVAL,
 PERMITTING, OR
 CONSTRUCTION

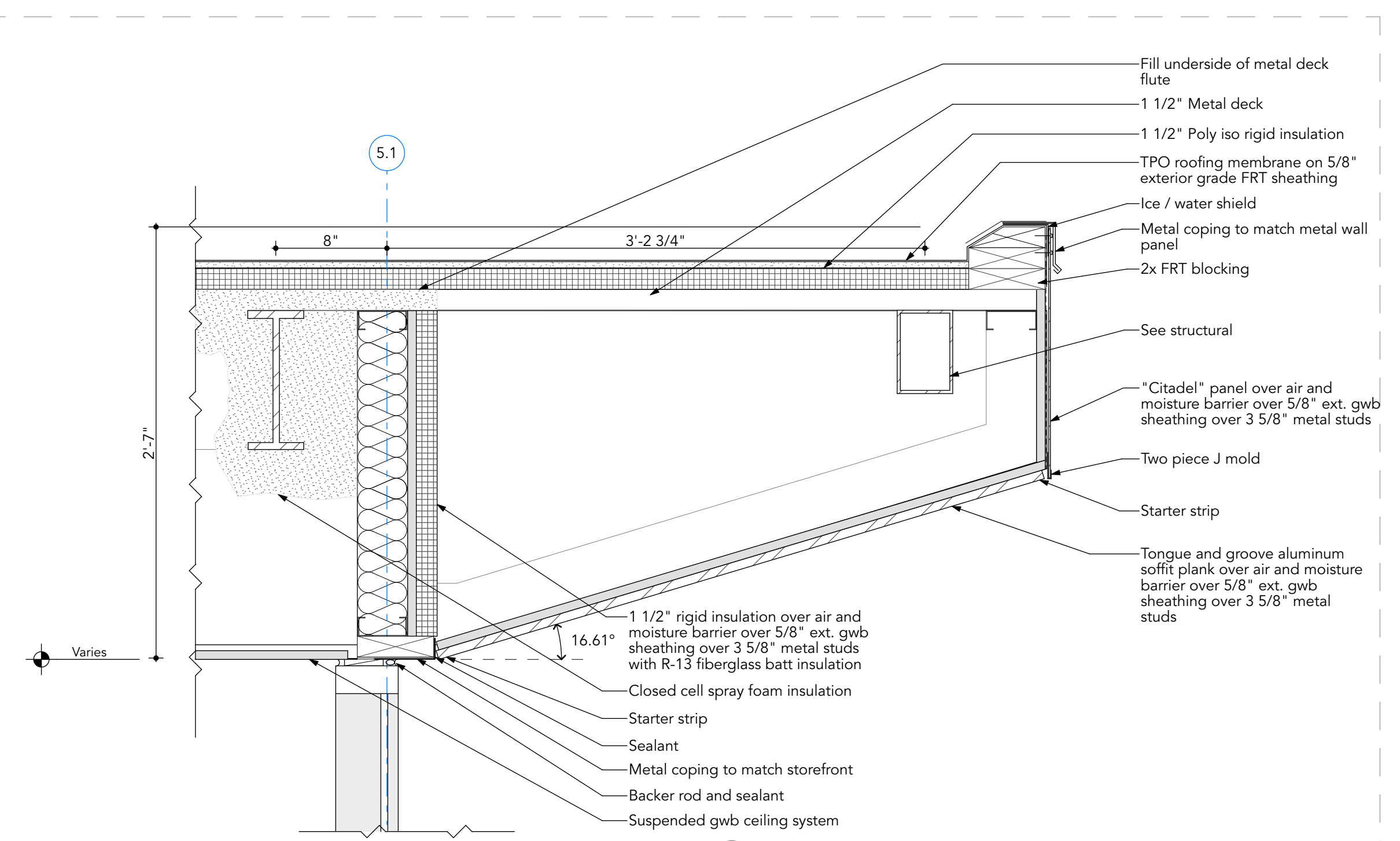
Bid Set 08/21/2025
 Site Plan Review 07/31/2025
 DD Set 07/03/2025
 © 2025, Intersect studio, llc
 Project Number: 23-046

Entry Canopy
 Details

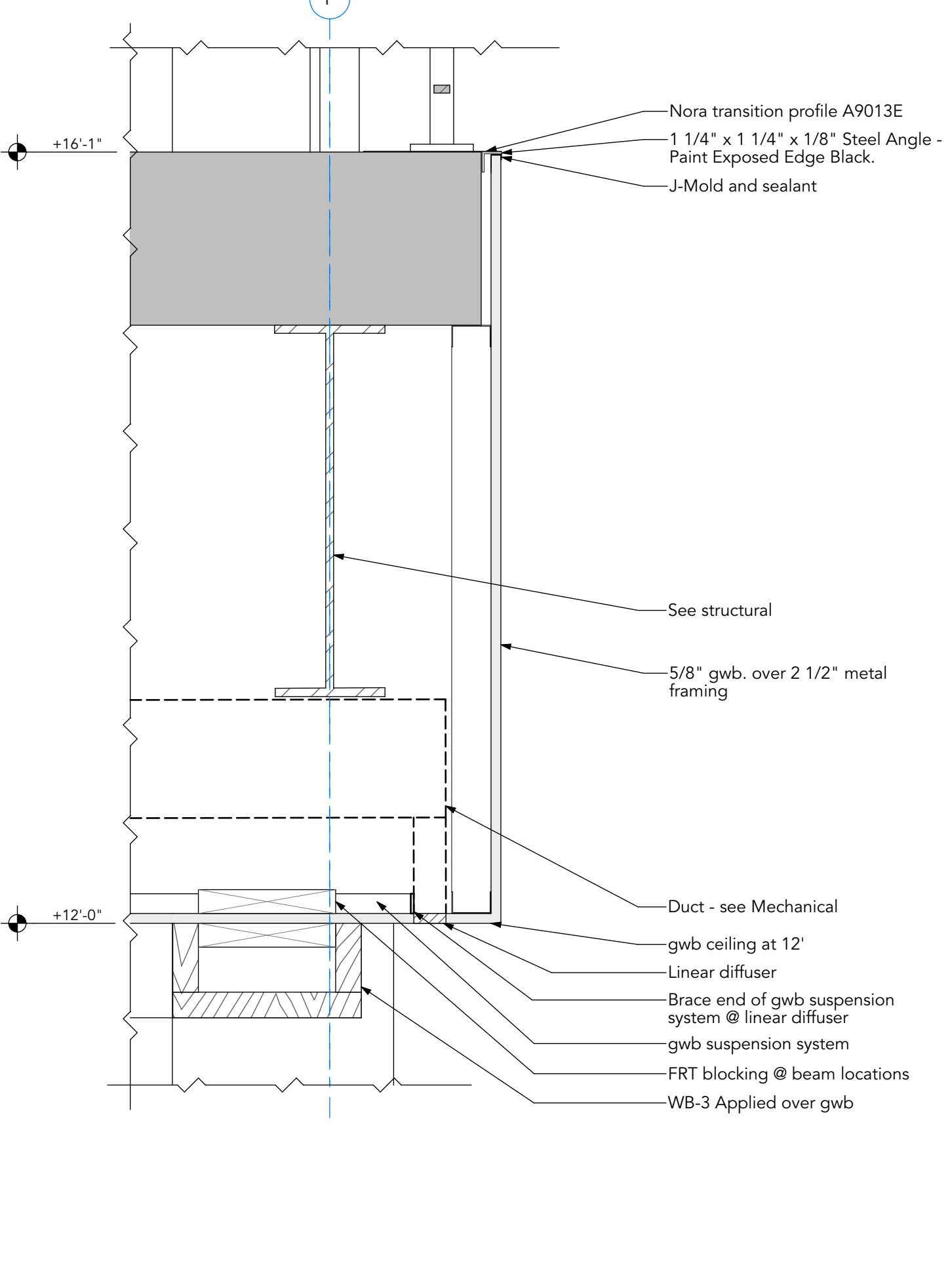
A306



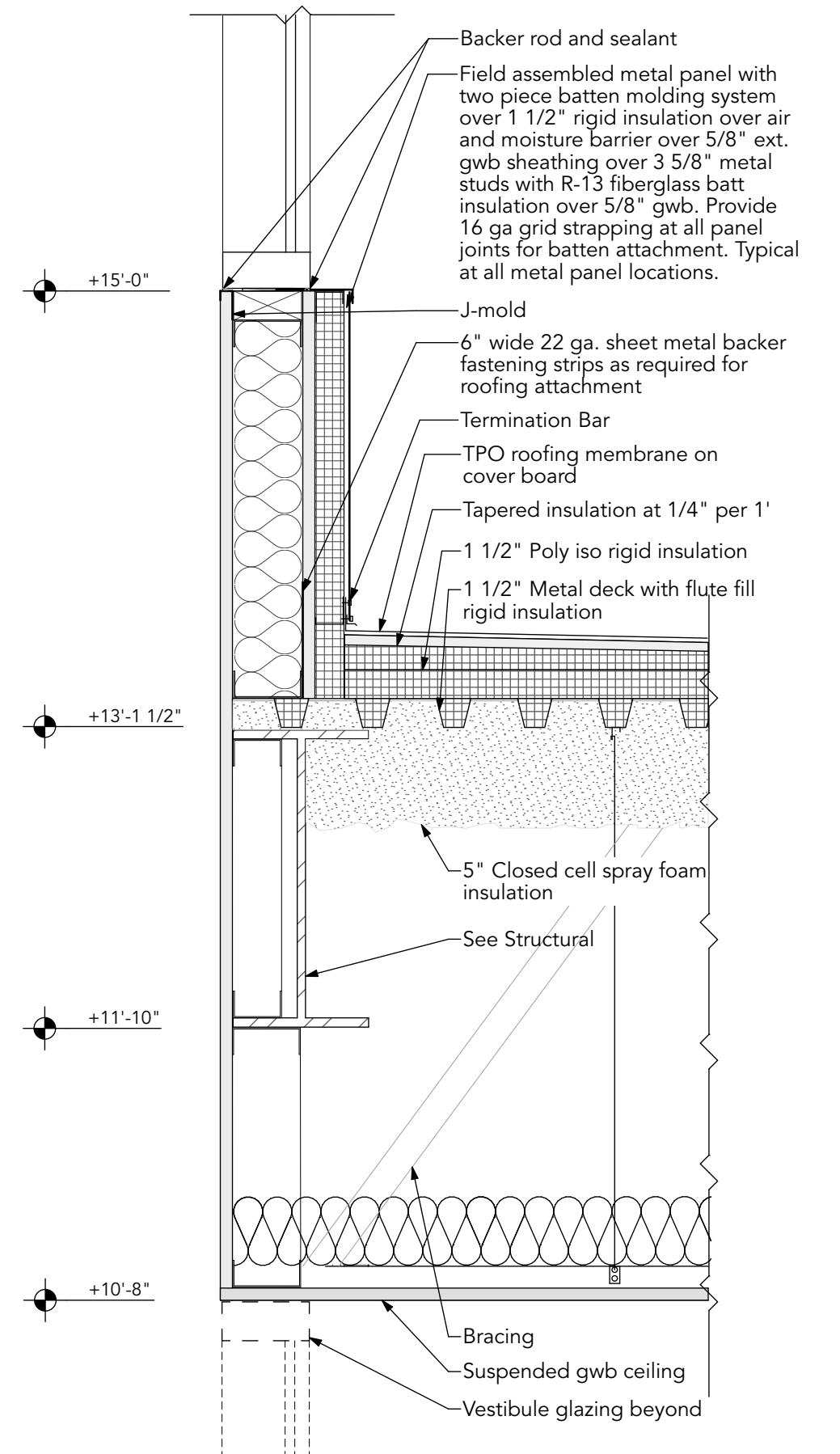
8 Entry Canopy Roof @ Existing Wall Detail
 A306 SCALE: 1 1/2" = 1'-0"



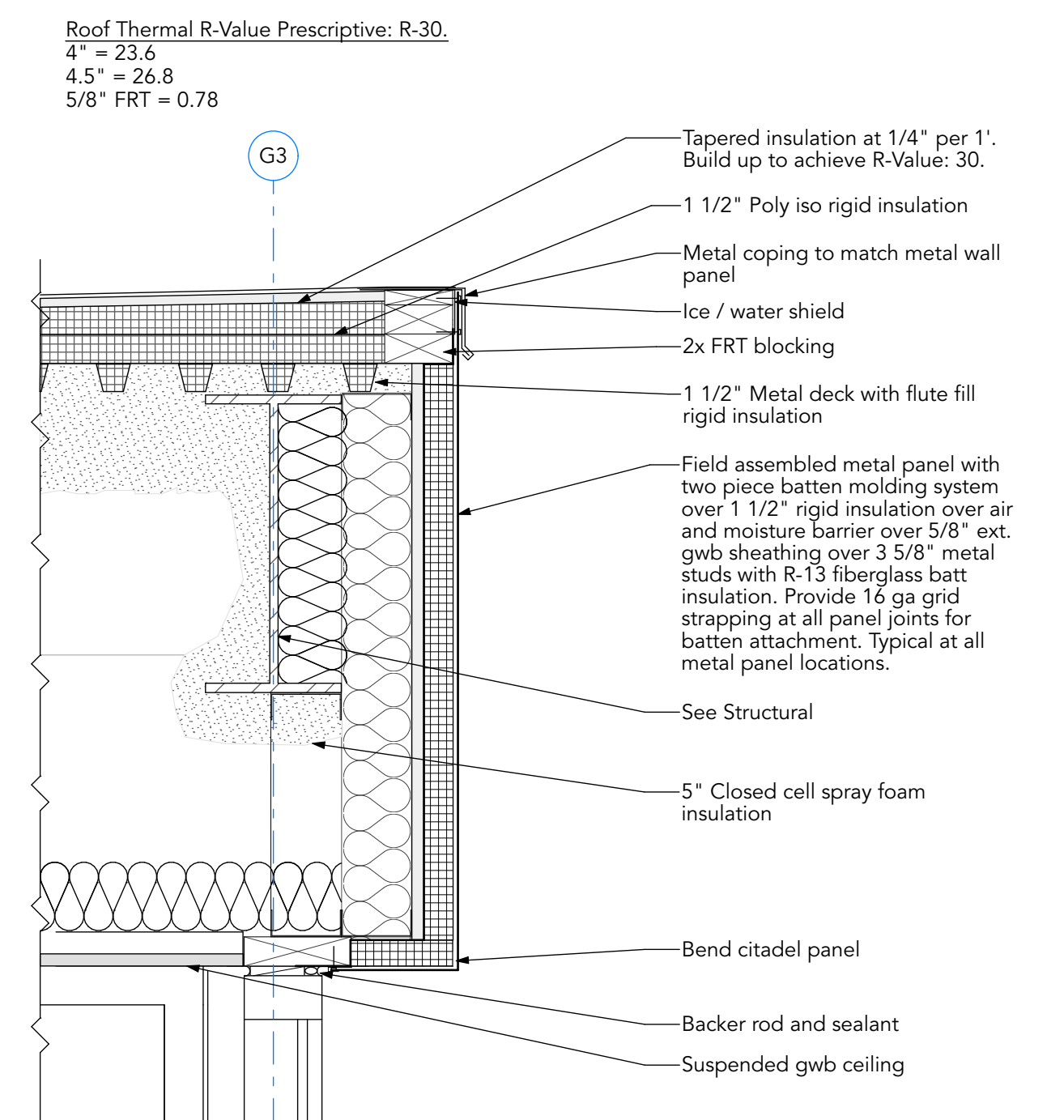
6 Entry Canopy Roof @ Edge Detail
 A306 SCALE: 1 1/2" = 1'-0"



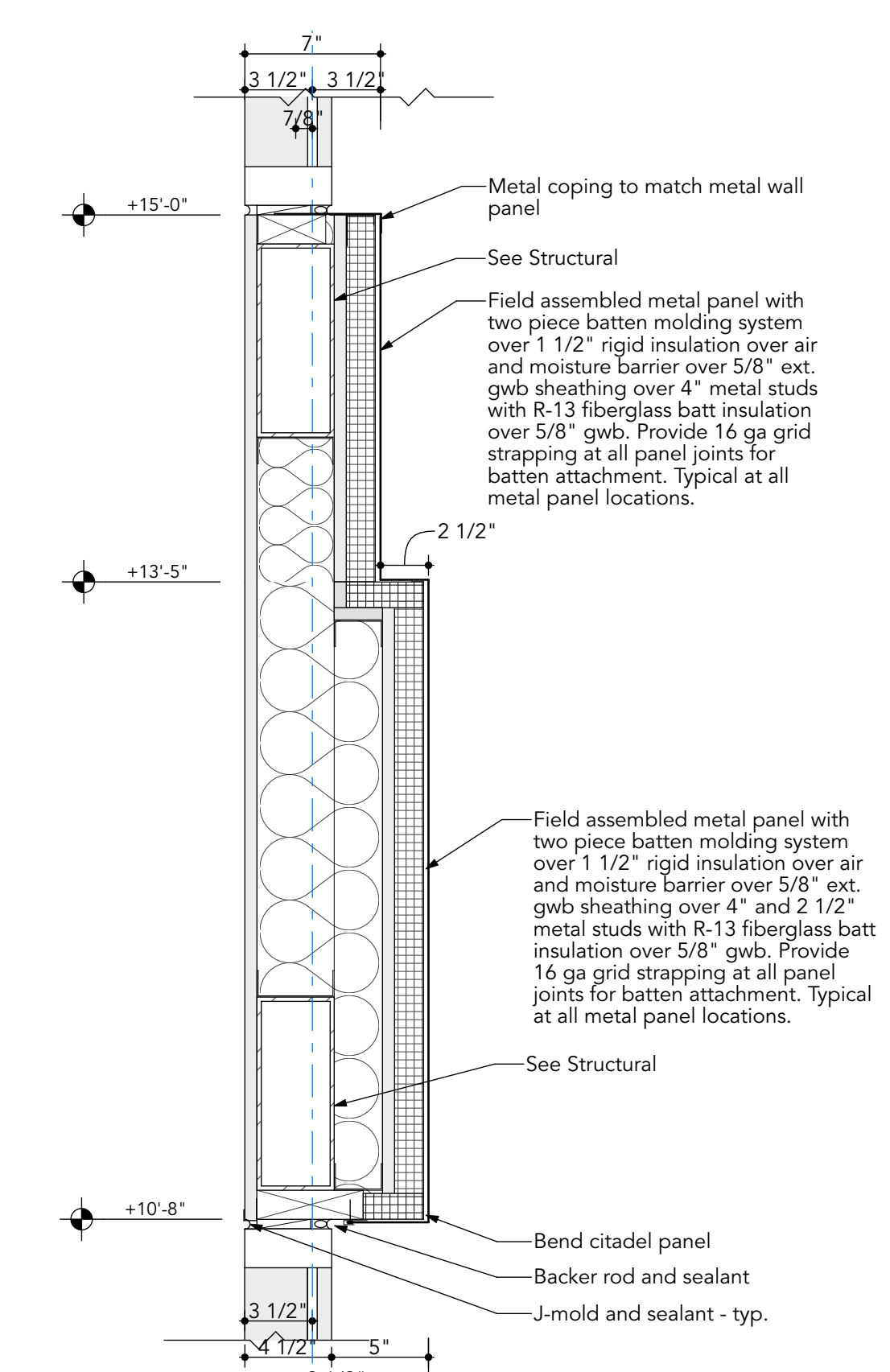
5 Entry Canopy @ Balcony Detail
 A306 SCALE: 1 1/2" = 1'-0"



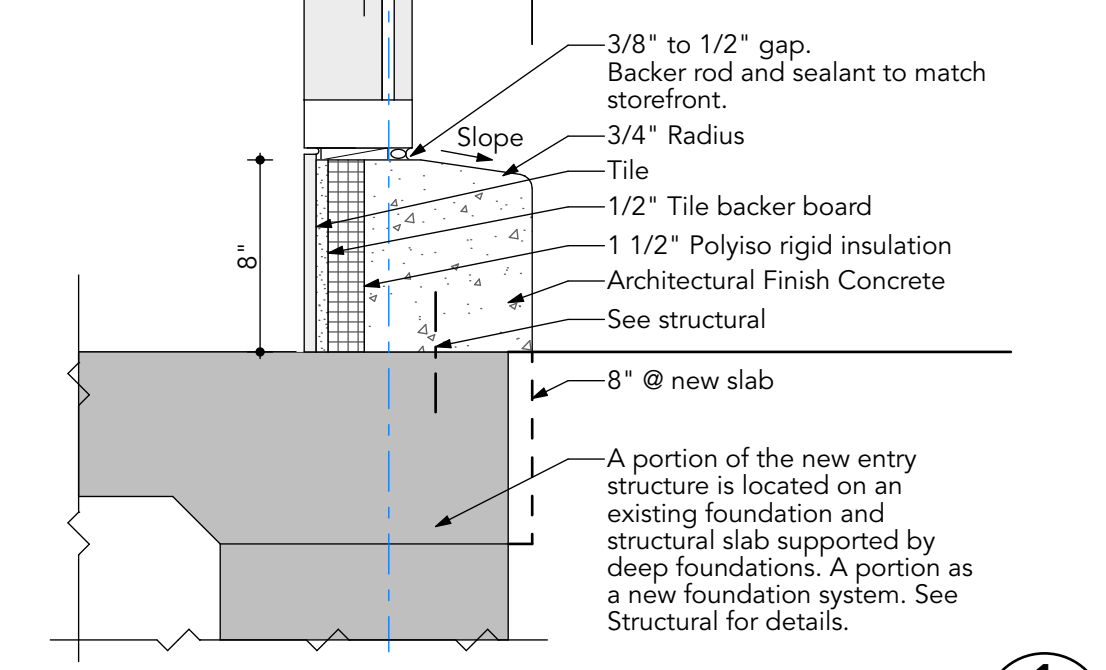
4 Entry Canopy @ Lower Roof to Wall Detail
 A306 SCALE: 1 1/2" = 1'-0"



3 Entry Canopy @ Lower Roof Edge Detail
 A306 SCALE: 1 1/2" = 1'-0"



2 Entry Canopy Panel Step Detail
 A306 SCALE: 1 1/2" = 1'-0"



1 Entry Canopy Base Detail
 A306 SCALE: 1 1/2" = 1'-0"

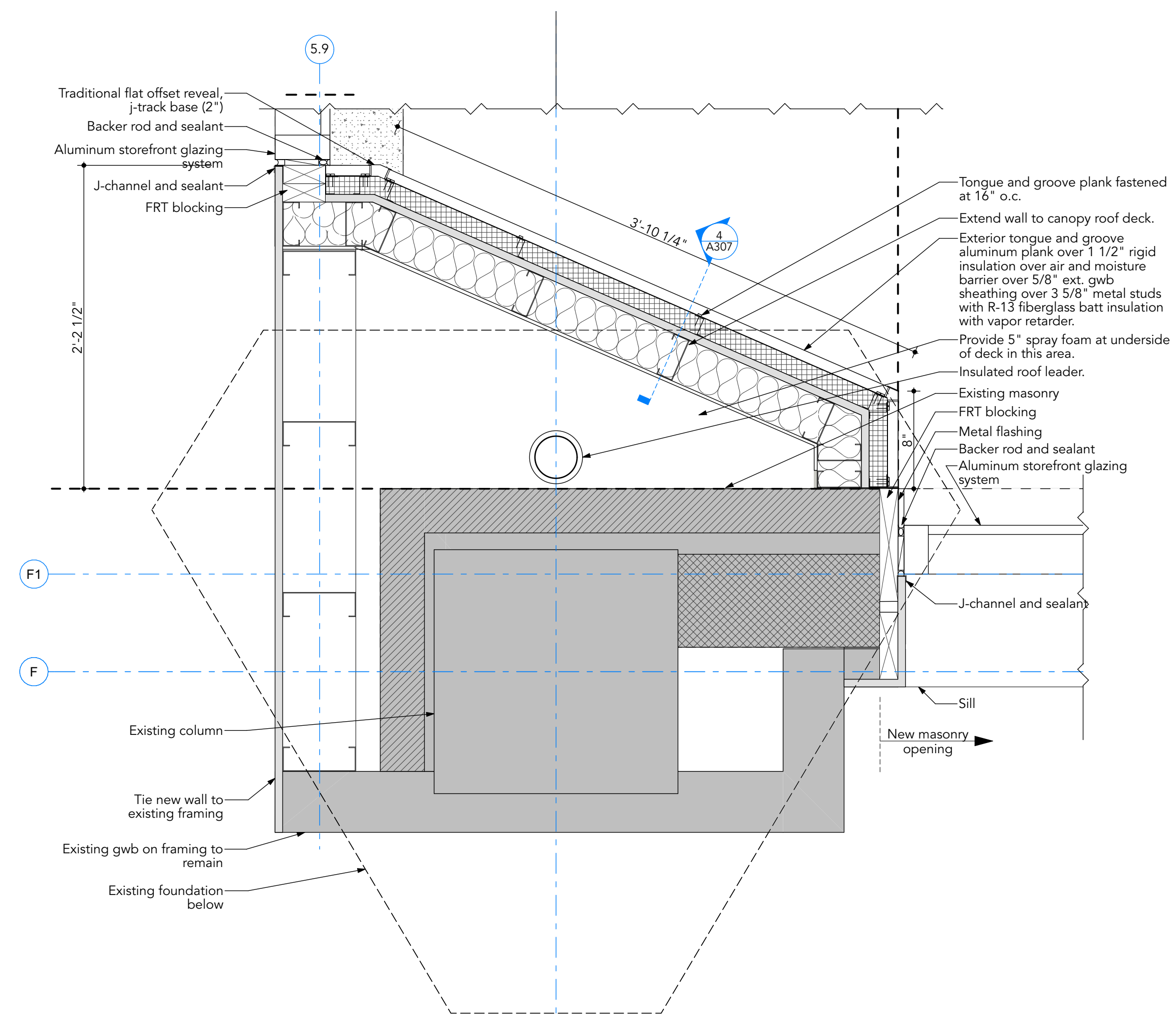
Roof Thermal R-Value Prescriptive: R-30.
 4" = 23.6
 4.5" = 26.8
 5/8" FRT = 0.78

NOT FOR
 REGULATORY
 APPROVAL,
 PERMITTING, OR
 CONSTRUCTION

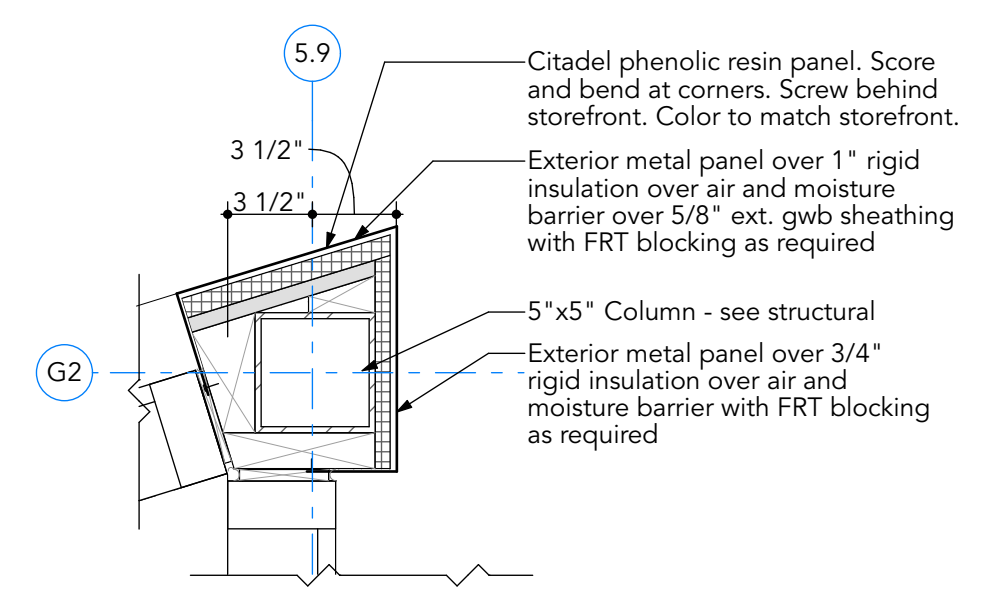
Bid Set 08/21/2025
 Site Plan Review 07/31/2025
 DD Set 07/03/2025
 © 2025, Intersect studio, llc
 Project Number: 23-046

Entry Canopy
 Details

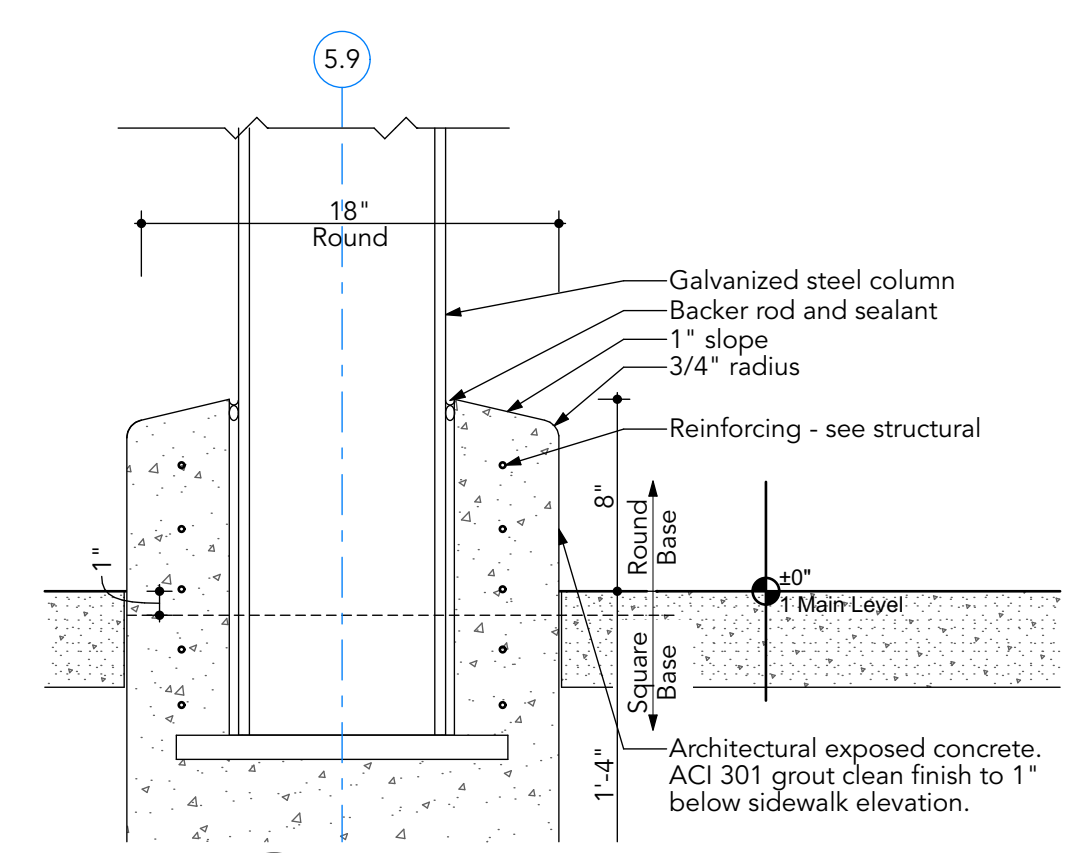
A307



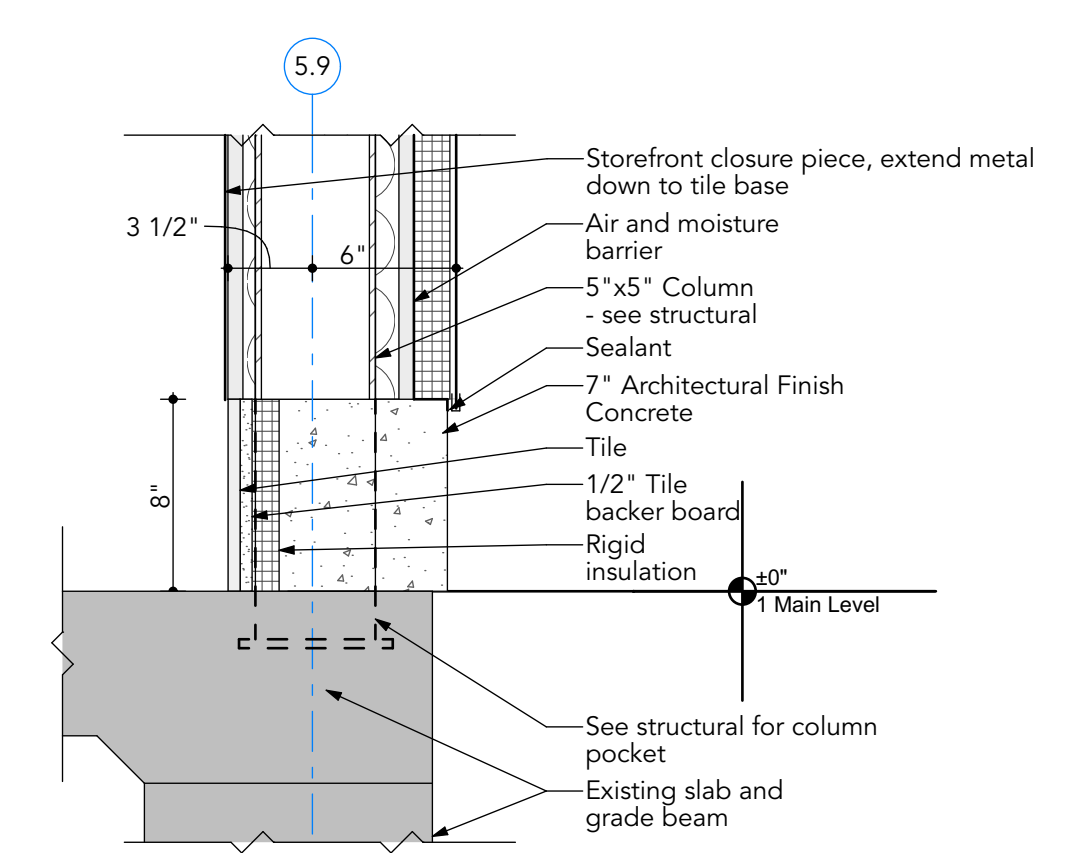
11 Entry to Existing Wall Plan Detail
 A307 SCALE: 1 1/2" = 1'-0"



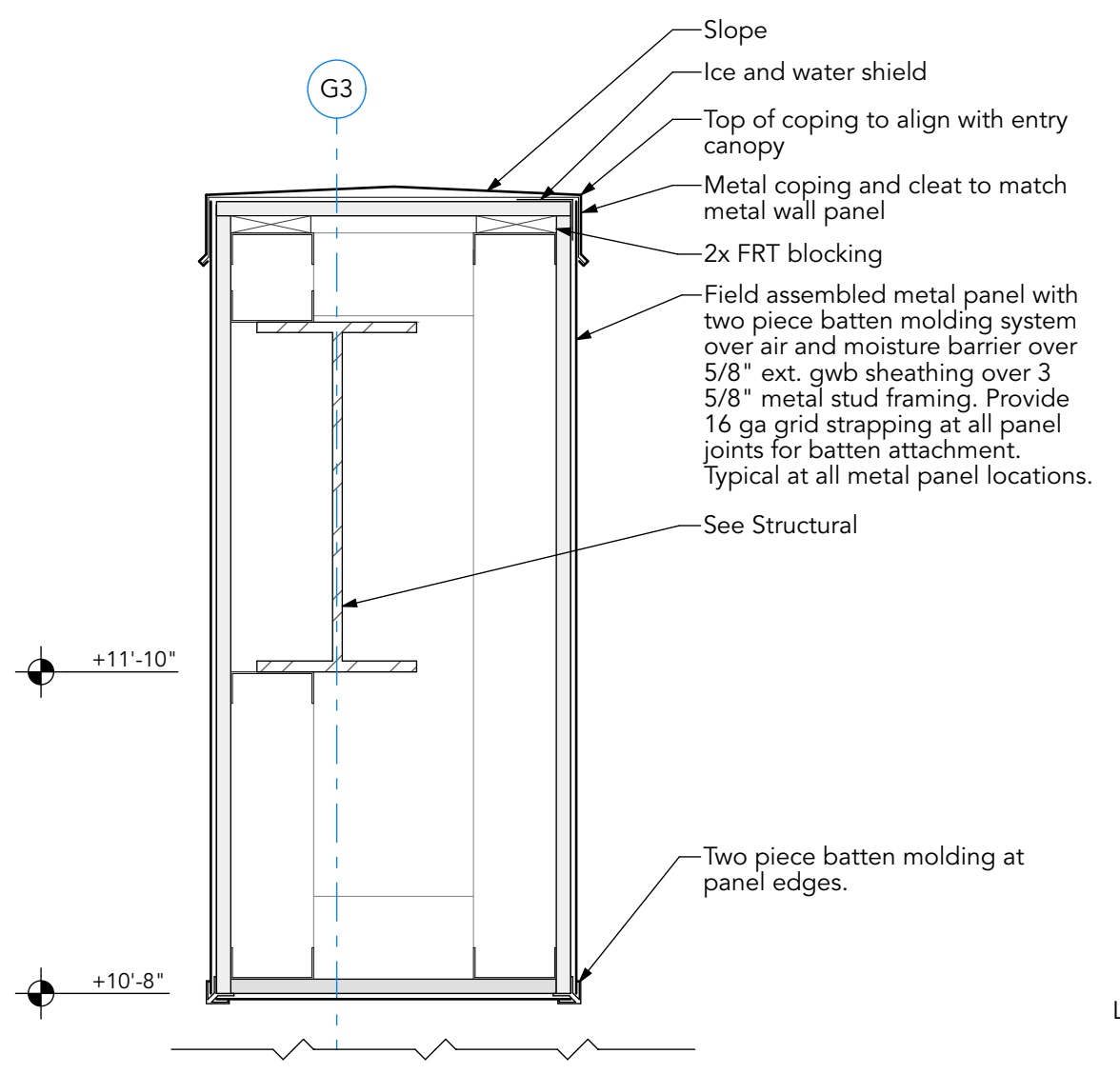
7 Entry Canopy Wall 2nd Fl @ Column Plan
 A307 SCALE: 1 1/2" = 1'-0"



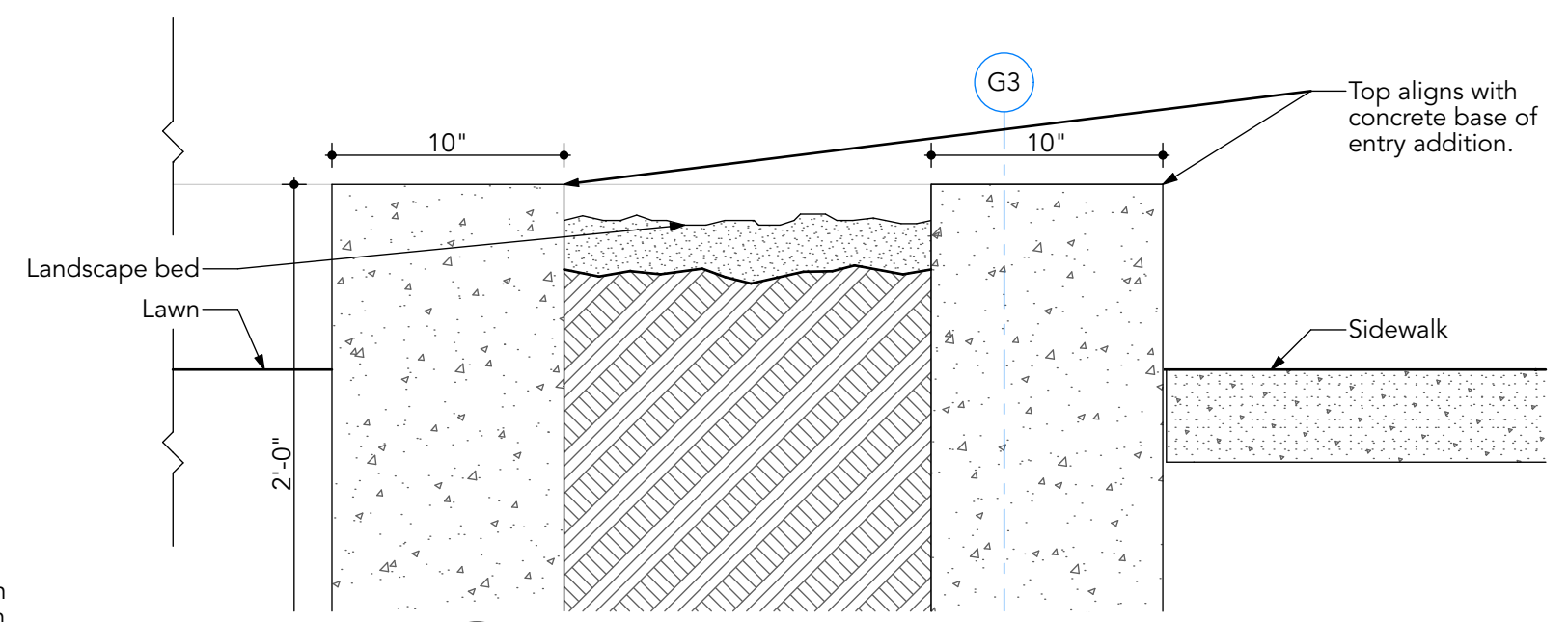
9 Entry Canopy Exterior Column Section Detail
 A307 SCALE: 1 1/2" = 1'-0"



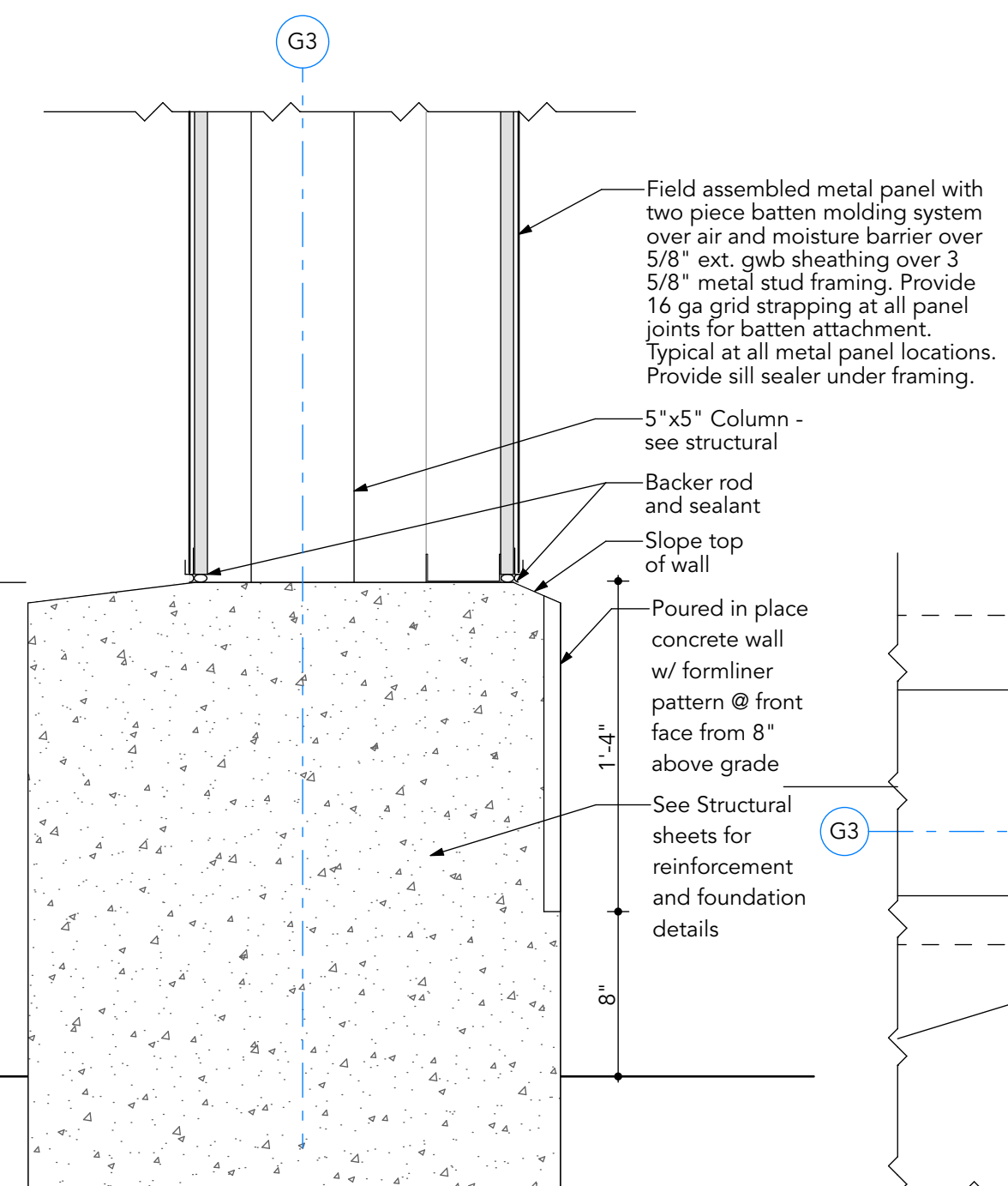
8 Entry Canopy Wall Base @ Column Detail
 A307 SCALE: 1 1/2" = 1'-0"



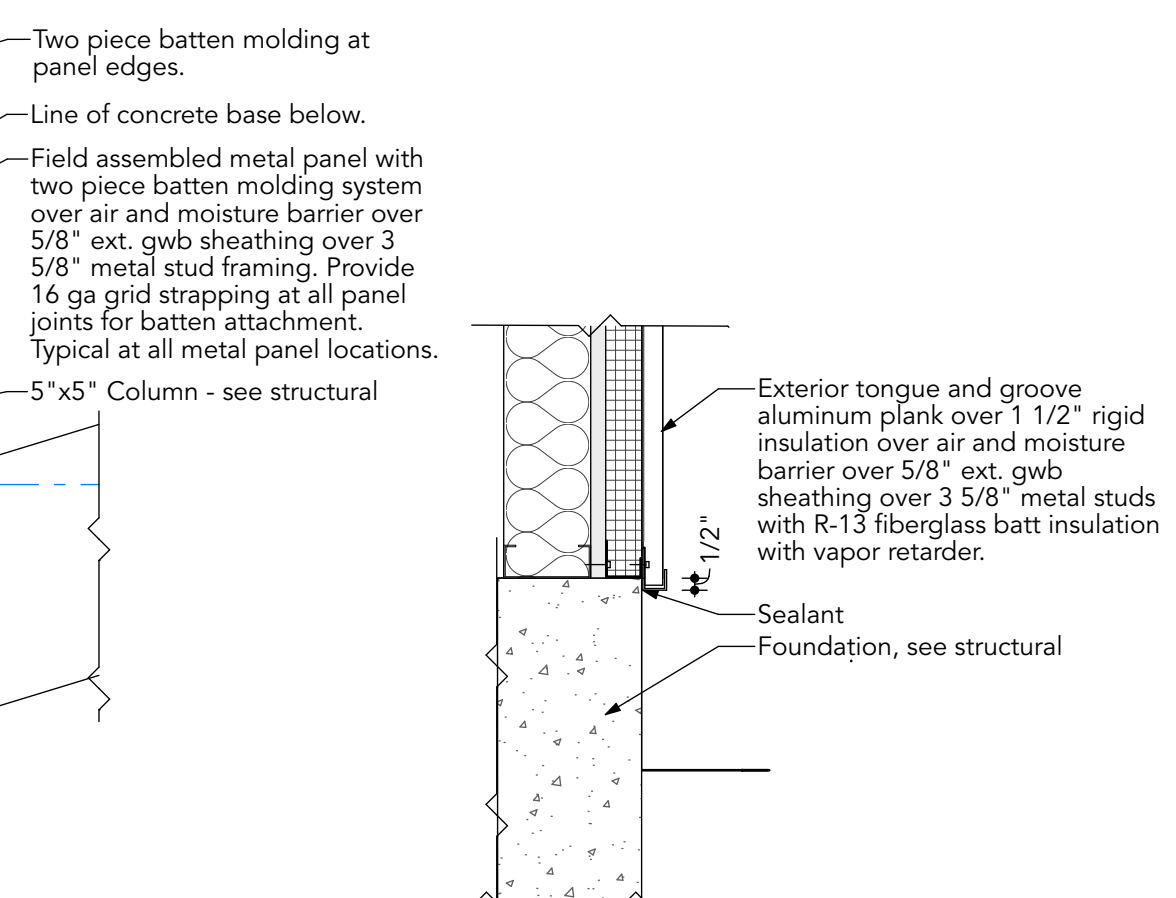
6 Entry Canopy Arm @ Column Section Detail
 A307 SCALE: 1 1/2" = 1'-0"



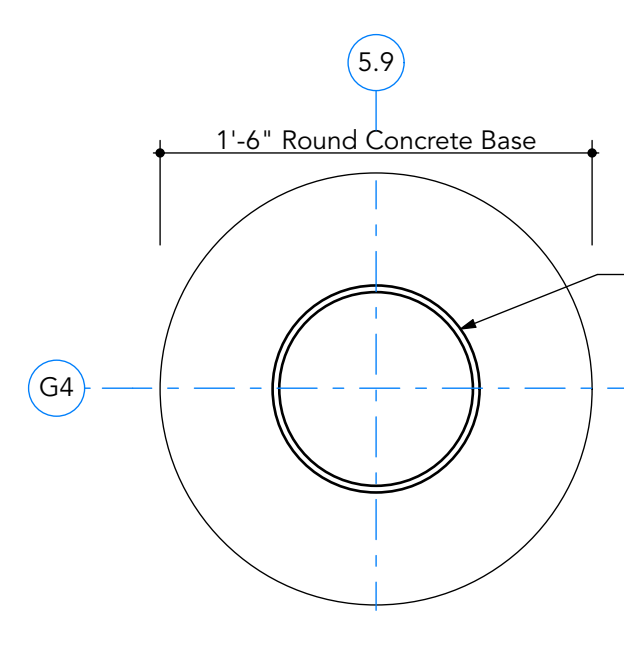
10 Entry Canopy Arm Section Detail
 A307 SCALE: 1 1/2" = 1'-0"



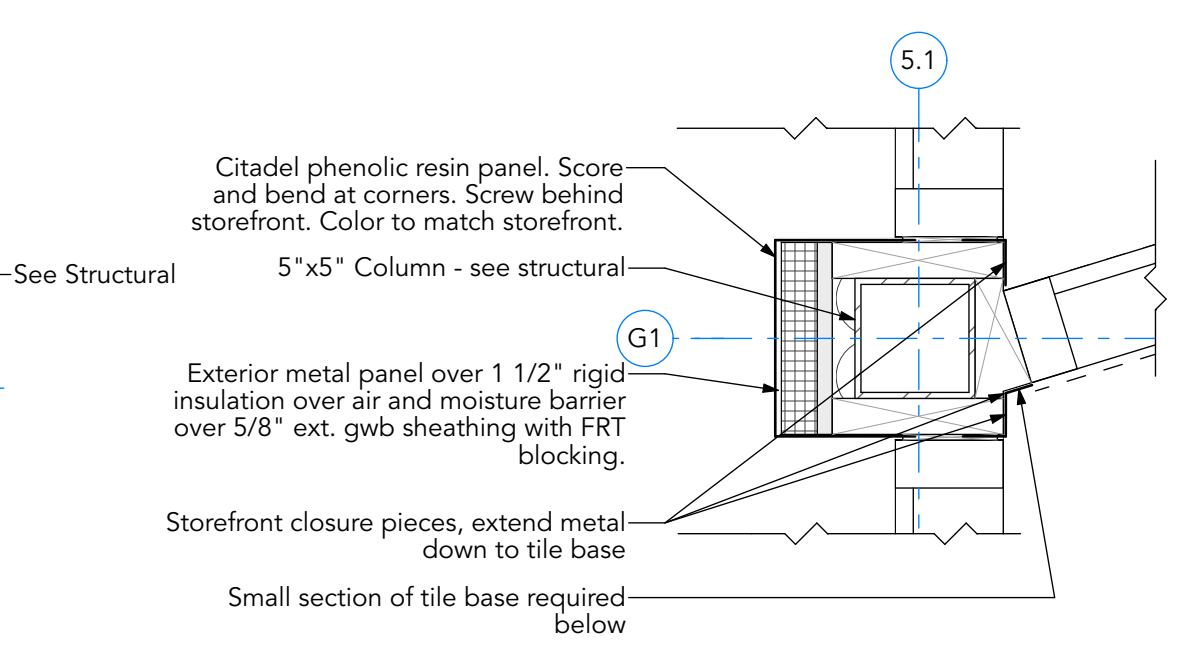
5 Entry Canopy Arm Plan Detail
 A307 SCALE: 1 1/2" = 1'-0"



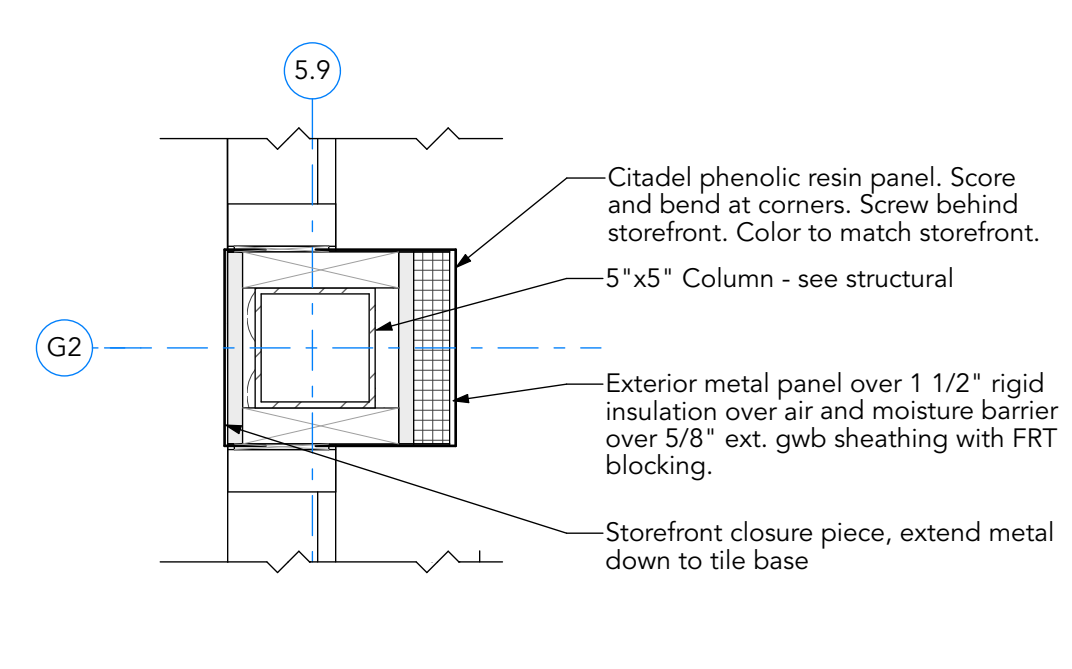
4 Entry to Existing Wall Section Detail
 A307 SCALE: 1 1/2" = 1'-0"



3 Entry Canopy Exterior Column Plan Detail
 A307 SCALE: 1 1/2" = 1'-0"



2 Entry Canopy Wall @ Column Plan
 A307 SCALE: 1 1/2" = 1'-0"



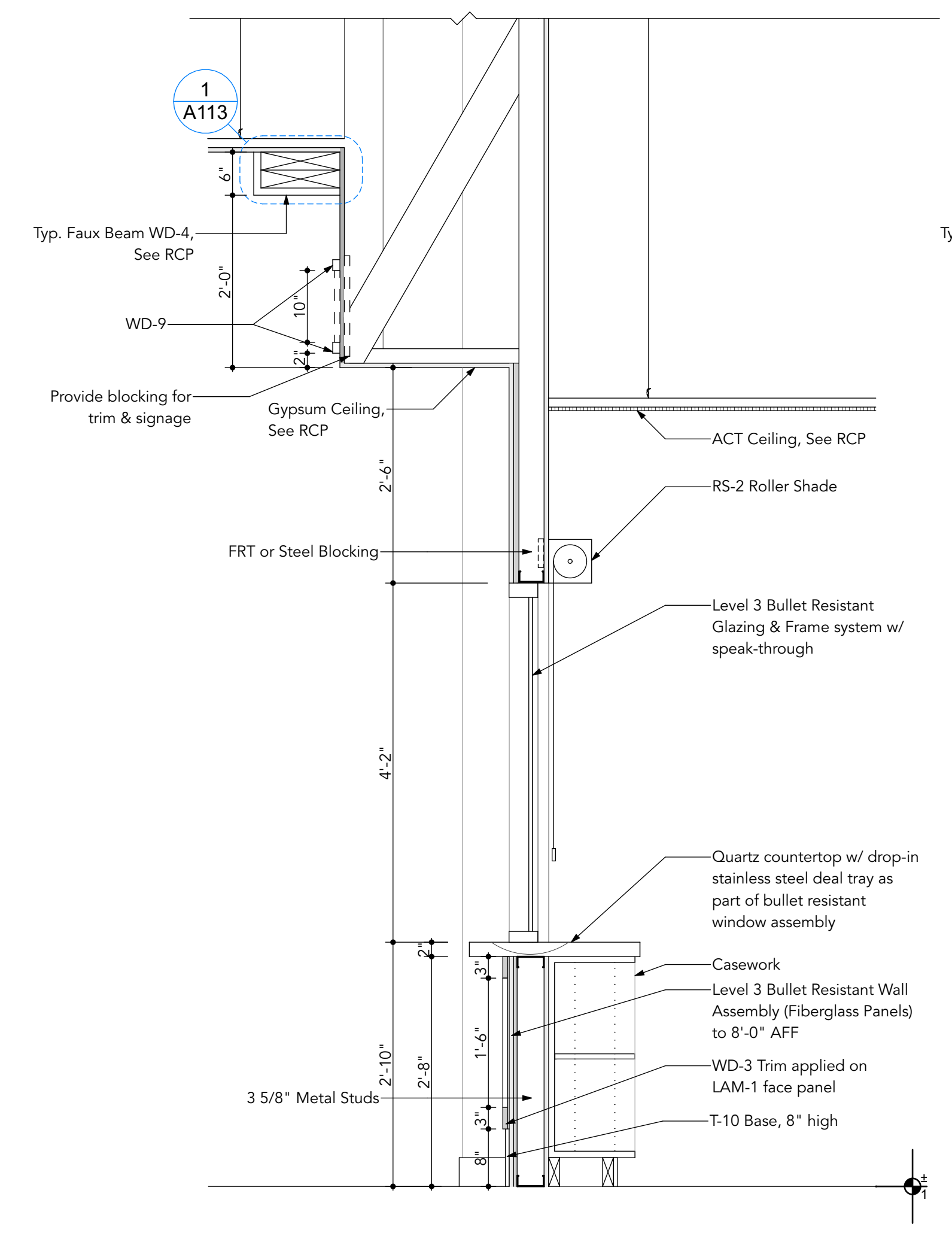
1 Entry Canopy Wall @ Column Plan
 A307 SCALE: 1 1/2" = 1'-0"

BIDDING: Intersect A307 Framework Server - BIMcloud Backup for Archival 27/25/2024 Kozio Crossstown150046 Kozio - Crossstown Facility

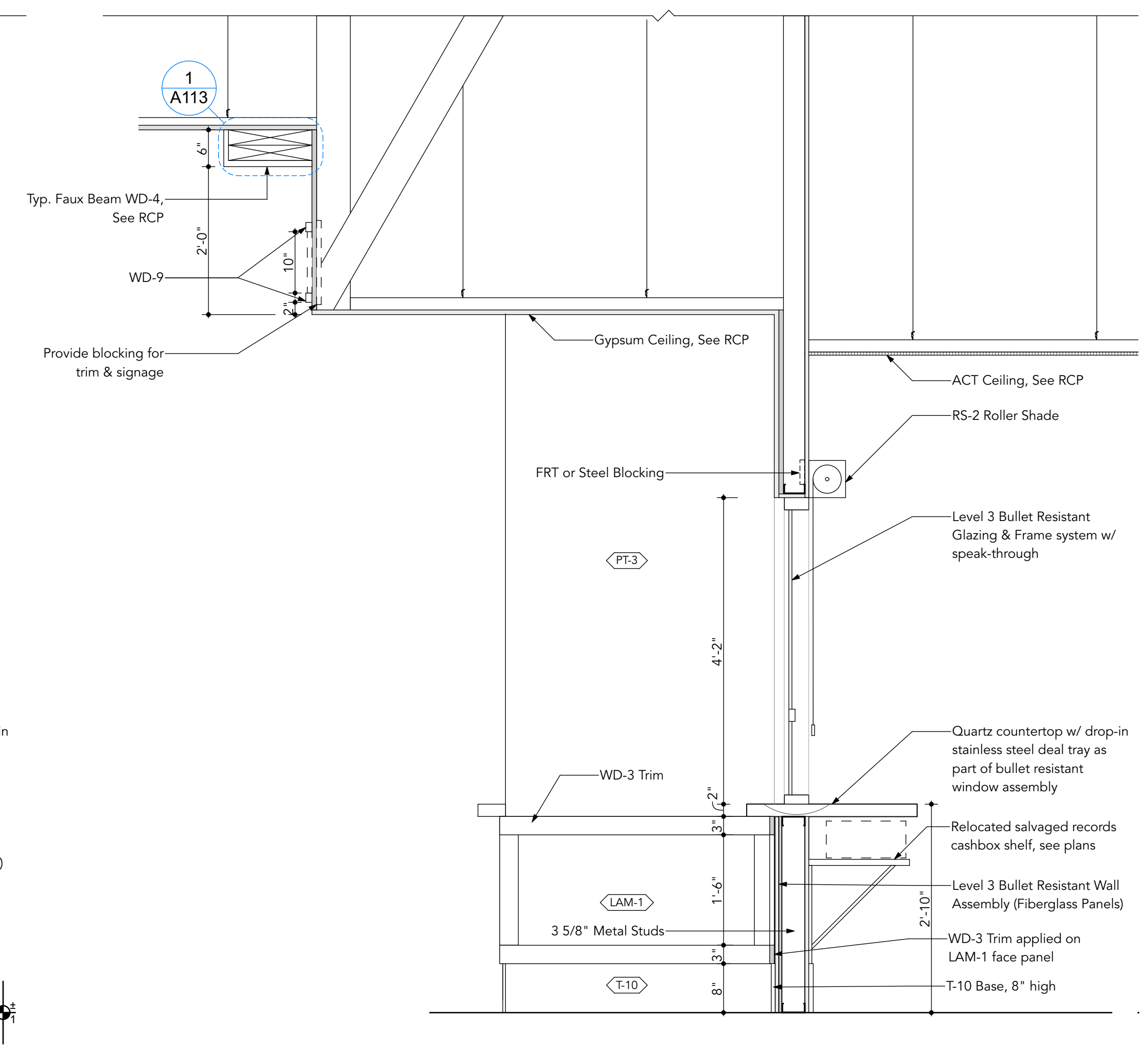
NOT FOR
 REGULATORY
 APPROVAL,
 PERMITTING, OR
 CONSTRUCTION

Bid Set 08/21/2025
 Site Plan Review 07/31/2025
 DD Set 07/03/2025
 © 2025, intersect studio, llc
 Project Number: 23-046

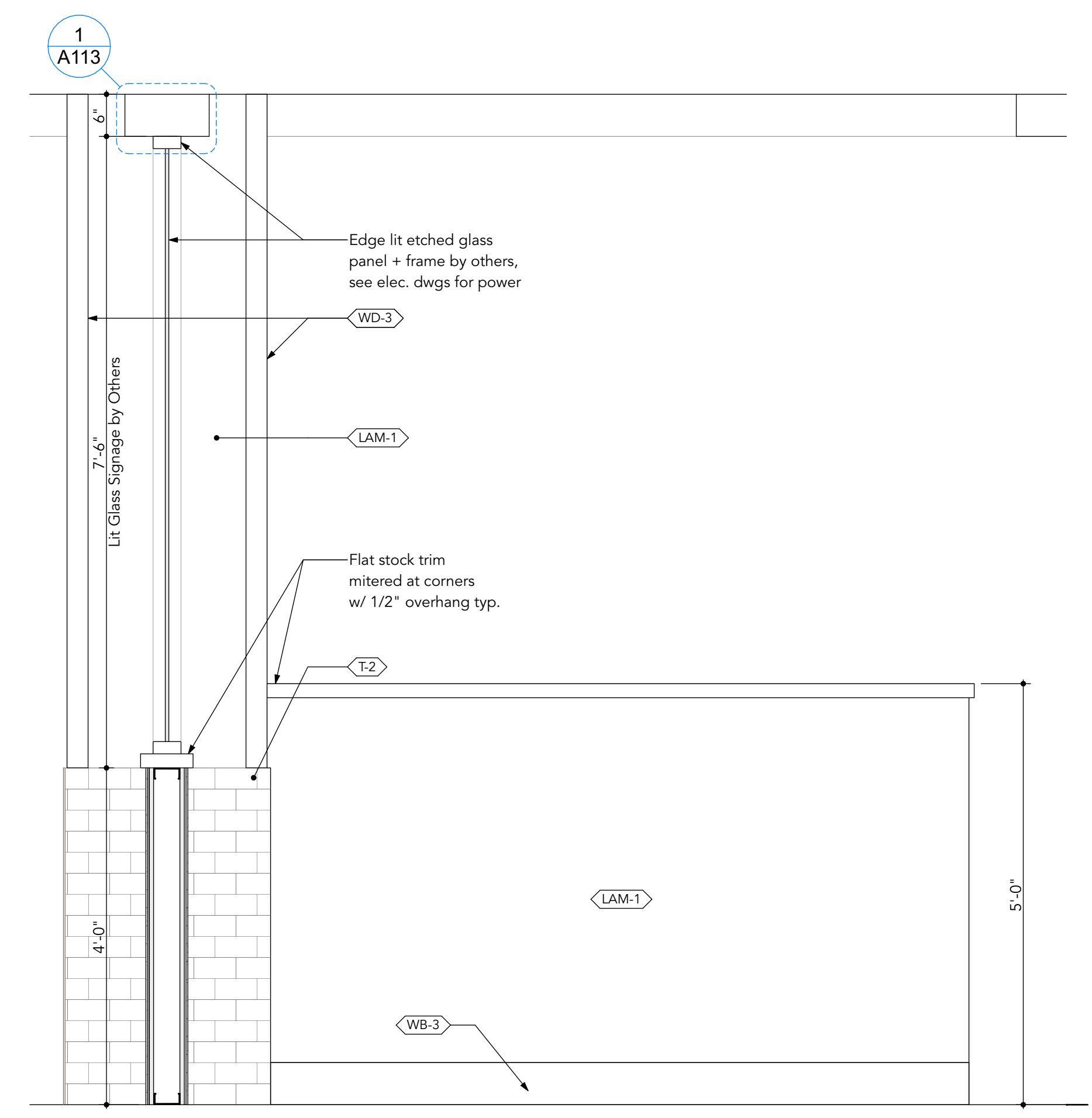
Details



3 Service Desk Section - Clerk
 A308 SCALE: 3/4" = 1'-0"



2 Service Desk Section - Records
 A308 SCALE: 3/4" = 1'-0"



1 Lobby Wall Section
 A308 SCALE: 3/4" = 1'-0"

9/25/25 - BIMcloud: Intersect A307 Framework: Server - BIMcloud: Intersect A307 Framework: Server - BIMcloud: Intersect A307 Framework: Server - BIMcloud: Intersect A307 Framework: Server - BIMcloud: Intersect A307 Framework: Server

NOT FOR
REGULATORY
APPROVAL,
PERMITTING, OR
CONSTRUCTION

Bid Set 08/21/2025
 Site Plan Review 07/31/2025
 DD Set 07/03/2025
 © 2025, Intersect Studio, LLC
 Project Number: 23-046

Door Schedule & Details

A401

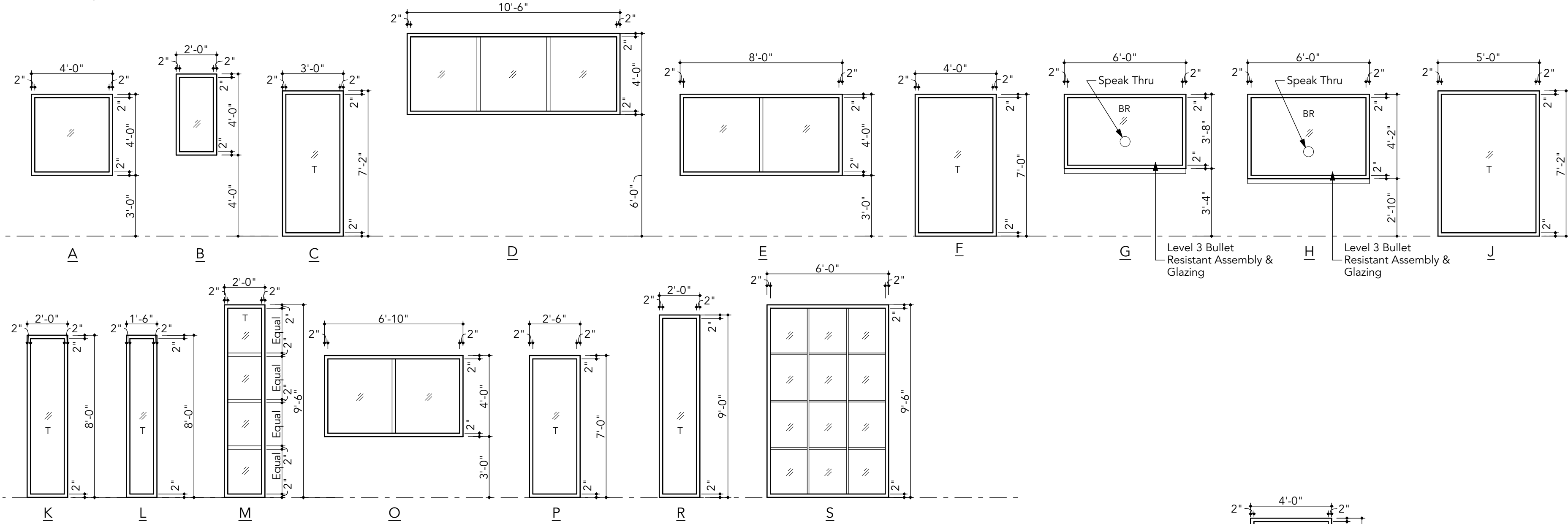
Door Hardware Sets	TAG	TYPE	DESCRIPTION	FINISH
A	Sliding Doors, Offices, Connect	18" Back to Back Ladder Pulls	Sliding door track with Soft Close - See Specifications	Satin Chrome US28
B	Swing Doors, Offices, Focus, Connect	Office lever set	Office lever set	Satin Chrome US28
C	Exterior Egress Door	12" Vertical Offset Pull	Wall Stop	Satin Chrome US28
		Continuous hinge	Exit device with surface rods, electric latch retraction/fail safe	Satin Chrome US28
		Card Reader & Electronic strike (fail safe) - coordinate with Owner's Tech vendor	Card Reader & Electronic strike (fail safe) - coordinate with Owner's Tech vendor	Satin Chrome US28
		Closer	Weatherstripping & Threshold	Satin Chrome US28
D	Single User Toilets, Wellness / Lactation, Recharge Rooms	Privacy lever set	Privacy lever set	Satin Chrome US28
		Rescue function	Rescue function	Satin Chrome US28
		Closer	Closer	Satin Chrome US28
		Occupancy indicator	Occupancy indicator	Satin Chrome US28
E	Main Entry Exterior Doors	18" Vertical Offset Pull	Wall Stop	Satin Chrome US28
		Continuous hinge	Exit device with trim	Satin Chrome US28
		Exit device with surface rods, electric latch retraction	Exit device with surface rods, electric latch retraction	Satin Chrome US28
		Auto operator with push button	Auto operator with push button	Satin Chrome US28
F	Entry Vestibule Interior Door	18" Vertical Offset Pull	Exit device with trim	Satin Chrome US28
		Closer	Closer	Satin Chrome US28
		Weatherstripping & Threshold	Weatherstripping & Threshold	Satin Chrome US28
		18" Vertical Offset Pull	Exit device with trim	Satin Chrome US28
G	Interior Secure Egress Doors	Continuous hinge	Exit device with trim	Satin Chrome US28
		Exit device with trim	Exit device with trim	Satin Chrome US28
		Closer	Closer	Satin Chrome US28
		Pull handle	Pull handle	Satin Chrome US28
H	Interior Egress Doors	Continuous hinge	Exit device with trim	Satin Chrome US28
		Exit device with trim	Exit device with trim	Satin Chrome US28
		Door w/ Hold Open	Door w/ Hold Open	Satin Chrome US28
		Pull handle	Pull handle	Satin Chrome US28
J	Passage Doors	Passage lever set	Passage lever set	Satin Chrome US28
		Kickdown door stop	Kickdown door stop	Satin Chrome US28
		Wall stop	Wall stop	Satin Chrome US28
		Lever set	Lever set	Satin Chrome US28
L	Secure Doors, Server Rooms	Wall stop	Wall stop	Satin Chrome US28
		Card Reader & Electronic strike (fail secure) - coordinate with Owner's Tech vendor	Card Reader & Electronic strike (fail secure) - coordinate with Owner's Tech vendor	Satin Chrome US28
		Closer	Closer	Satin Chrome US28
		Push/pull plates	Push/pull plates	Satin Chrome US28
M	Multi User Restroom	Closer	Closer	Satin Chrome US28
		Push/pull plates	Push/pull plates	Satin Chrome US28
		Kickplate	Kickplate	Satin Chrome US28
		Lever set	Lever set	Satin Chrome US28
N	Hold Open Fire Door	Exit device with trim	Exit device with trim	Satin Chrome US28
		Electromagnetic Hold Open w/ Emergency Release	Electromagnetic Hold Open w/ Emergency Release	Satin Chrome US28
		Closer	Closer	Satin Chrome US28
		Passage Lever set	Passage Lever set	Satin Chrome US28
P	Passage Fire Door	Wall stop	Wall stop	Satin Chrome US28
		Closer	Closer	Satin Chrome US28
		Motorized Security Grille w/ Emergency Open - see specifications	Motorized Security Grille w/ Emergency Open - see specifications	Satin Chrome US28
		Key Controlled Door Raise/Lower	Key Controlled Door Raise/Lower	Satin Chrome US28
NOTES	1	Provide hardware submittal for review by architect.		
	2	Lever sets shall be Schlage Sparto or equivalent - provided as basis of design.		

ID	STATUS	DOOR				FRAME				HDW	REMARKS		
		W	H	MTL	Type	Finish	MTL	Type	HEAD			JAMB	THRESH
Main Level													
100	New	3'-0"	7'-0"	GL; SC WD	D2	DF-3	ALUM	F2	3/A403	4/A403	-	B	-
101	New	3'-0"	7'-0"	GL; SC WD	D2	DF-3	ALUM	F1	3/A403	4/A403	-	B	-
102	New	3'-0"	7'-0"	SC WD	D1	DF-3	HM	F1	1/A403	2/A403	-	D	-
103	New	9'-3"	9'-0"	-	-	-	-	-	-	-	-	-	Finished Opening
104	New	3'-0"	7'-0"	SC WD	D1	DF-2	HM	EXIST.	-	-	-	B	New door in exist frame
105	New	3'-0"	7'-0"	GL; SC WD	D2	DF-2	HM	EXIST.	-	-	-	B	New door in exist frame
106	New	3'-0"	7'-0"	GL; SC WD	D2	DF-2	ALUM	F4	3/A403	4/A403	-	B	-
106B	New	5'-0"	6'-8"	SC WD	D1	DF-2	ALUM	F1	3/A403	4/A403	-	J	(2) 3'-0" doors
106C	New	5'-0"	6'-8"	SC WD	D1	DF-2	ALUM	F1	3/A403	4/A403	-	J	(2) 3'-0" doors
107	New	3'-0"	7'-0"	GL; SC WD	D2	DF-3	ALUM	F3	3/A403	4/A403	-	B	-
108	New	8'-4"	7'-2"	GL; SC WD	D2	DF-3	ALUM	F13	6/A403	-	6/A403	A	-
109	New	3'-0"	7'-0"	SC WD	D1	DF-3	HM	F1	1/A403	2/A403	-	J	-
110	New	3'-0"	7'-0"	GL; SC WD	D2	DF-3	ALUM	F2	3/A403	4/A403	-	B	-
112	New	3'-0"	7'-0"	GL; SC WD	D2	DF-3	ALUM	F2	3/A403	4/A403	-	B	-
113	New	3'-0"	7'-0"	GL; SC WD	D2	DF-3	HM	EXIST.	-	-	-	B	New door in exist frame
117A	New	8'-0"	8'-0"	-	-	-	-	-	-	-	-	-	Finished Opening
117B	New	6'-0"	8'-0"	-	-	-	-	-	-	-	-	-	Finished Opening
119	New	6'-0"	7'-0"	SC WD	D1	DF-3	ALUM	F1	3/A403	4/A403	-	J	(2) 3'-0" doors
123	New	4'-0"	7'-0"	-	-	-	-	-	-	-	-	-	Finished Opening
126	New	6'-0"	8'-0"	-	-	-	-	-	-	-	-	-	Finished Opening
128	New	6'-4"	7'-2"	GL; SC WD	D2	DF-3	ALUM	F16	6/A403	-	6/A403	A	-
131	New	8'-4"	7'-2"	GL; SC WD	D2	DF-3	ALUM	F13	6/A403	-	6/A403	A	-
132	New	8'-4"	7'-2"	GL; SC WD	D2	DF-3	ALUM	F13	6/A403	-	6/A403	A	-
133	New	8'-4"	7'-2"	GL; SC WD	D2	DF-3	ALUM	F13	6/A403	-	6/A403	A	-
134	New	8'-4"	7'-2"	GL; SC WD	D2	DF-3	ALUM	F13	6/A403	-	6/A403	A	-
135	New	7'-4"	7'-2"	GL; SC WD	D2	DF-3	ALUM	F15	6/A403	-	6/A403	A	-
136	New	7'-4"	7'-2"	GL; SC WD	D2	DF-3	ALUM	F15	6/A403	-	6/A403	A	-
137	New	3'-0"	7'-0"	GL; SC WD	D2	DF-3	ALUM	F1	3/A403	4/A403	-	L	-
140	New	3'-0"	7'-0"	GL; SC WD	D2	DF-3	ALUM	F2	3/A403	4/A403	-	B	-
141	New	3'-3"	7'-0"	GL; SC WD	D2	DF-3	ALUM	F17	5/A403	-	5/A403	A	-
142	New	3'-2"	7'-0"	GL; SC WD	D2	DF-3	ALUM	F17	5/A403	-	5/A403	A	-
145	New	3'-6"	7'-0"	-	-	-	-	-	-	-	-	-	Finished Opening
146	New	3'-0"	7'-0"	HM	D1	-	HM	F1	1/A403	2/A403	-	L	Bullet Resistant Door & Frame
147A	New	3'-0"	7'-0"	HM	D1	-	HM	F1	1/A403	2/A403	-	J	-
147B	New	3'-0"	7'-0"	HM	D1	-	HM	F1	1/A403	2/A403	-	J	-
149	New	3'-0"	7'-0"	GL; SC WD	D2	DF-3	ALUM	F11	3/A403	4/A403	-	B	-
150	New	3'-0"	7'-0"	GL; SC WD	D2	DF-3	ALUM	F11	3/A403	4/A403	-	B	-
151	New	3'-0"	7'-0"	GL; SC WD	D1	DF-2	ALUM	F8	3/A403	4/A403	-	B	-
153	New	3'-0"	7'-0"	GL; SC WD	D2	DF-3	ALUM	F8	3/A403	4/A403	-	L	-
154	New	3'-0"	7'-0"	HM	D1	-	HM	F1	1/A403	2/A403	-	J	-
157	New	7'-4"	7'-2"	GL; SC WD	D2	DF-3	ALUM	F15	6/A403	-	6/A403	A	-
160	New	3'-0"	7'-0"	SC WD	D1	Reuse Exist.	HM	F1	1/A403	2/A403	-	G	Reuse Exist Door/Frame
163	New	3'-0"	7'-0"	SC WD	D1	DF-3	HM	F1	1/A403	2/A403	-	G	-
164	New	3'-0"	7'-0"	SC WD	D1	DF-3	HM	F1	1/A403	2/A403	-	G	-
165A	New	3'-0"	7'-0"	GL; SC WD	D2	DF-3	HM	F1	1/A403	2/A403	-	J	-
165B	New	3'-0"	7'-0"	SC WD	D1	DF-2	HM	F1	1/A403	2/A403	-	G	-
166	New	3'-0"	7'-0"	HM	D1	-	HM	F1	1/A403	2/A403	-	J	-
167	New	3'-0"	7'-0"	GL; SC WD	D2	DF-2	ALUM	F8	3/A403	4/A403	-	B	-
168	New	3'-0"	7'-0"	ALUM; GL	D2	DF-2	ALUM	F4	3/A403	4/A403	-	G	Bullet Resist. Assembly & Glaz
169	New	3'-0"	7'-0"	GL; SC WD	D2	DF-2	ALUM	F4	3/A403	4/A403	-	B	-
170A	New	6'-0"	8'-0"	ALUM; GL	D2	Champ Anod	ALUM	X6	3/A306	1/A307	7/A301	E	(2) 3'-0" Doors
170B	New	3'-0"	8'-0"	ALUM; GL	D2	Champ Anod	ALUM	X6	3/A306	1/A307	7/A301	E	-
171A	New	6'-0"	8'-0"	ALUM; GL	D2	Champ Anod	ALUM	X10	3/A403	4/A403	-	F	(2) 3'-0" Doors
171B	New	3'-0"	8'-0"	ALUM; GL	D2	Champ Anod	ALUM	X10	3/A403	4/A403	-	F	-
176	New	3'-0"	7'-0"	GL; SC WD	D1	DF-2	HM	F9	1/A403	2/A403	-	B	-
177	New	3'-0"	7'-0"	SC WD	D2	DF-2	ALUM	F1	3/A403	4/A403	-	P	1 Hour Fire Rated
178	New	3'-6"	7'-0"	-	-	-	-	-	-	-	-	-	Cased Opening
179A	New	3'-0"	7'-0"	HM	D1	-	HM	F1	1/A403	2/A403	-	L	Bullet Resistant Door & Frame
179B	New	3'-0"	7'-0"	HM	D1	-	HM	F4	1/A403	2/A403	-	L	Bullet Resist. Assembly & Glaz
181	New	3'-0"	7'-0"	GL; SC WD	D2	DF-2	ALUM	F5	3/A403	4/A403	-	G	-
182A	New	3'-0"	7'-0"	GL; SC WD	D2	DF-2	ALUM	F6	3/A403	4/A403	-	B	-
182B	New	3'-0"	7'-0"	HM	D2	-	HM	F1	1/A403	2/A403	-	L	-
183	New	3'-0"	7'-0"	GL; SC WD	D2	DF-2	ALUM	F2	3/A403	4/A403	-	B	-
184	New	3'-0"	7'-0"	SC WD	D1	Reuse Exist.	HM	F1	1/A403	2/A403	-	B	Reuse Exist Door/Frame
185	New	3'-0"	7'-0"	GL; SC WD	D2	DF-2	ALUM	F4	3/A403	4/A403	-	G	-
186	New	3'-0"	7'-0"	GL; SC WD	D2	DF-2	ALUM	F4	3/A403	4/A403	-	B	-
187	New	3'-0"	7'-0"	GL; SC WD	D2	DF-2	ALUM	F4	3/A403	4/A403	-	B	-
188	New	3'-0"	7'-0"	SC WD	D1	DF-2	HM	F1	1/A403	2/A403	-	D	-
189	New	3'-0"	7'-0"	SC WD	D1	DF-2	HM	F1	1/A403	2/A403	-	D	-
190	New	3'-0"	7'-0"	SC WD	D1	DF-2	HM	F1	1/A403	2/A403	-	P	1 Hour Fire Rated
191A	New	6'-0"	7'-0"	ALUM; GL	D2	DK Bronze	ALUM	X8	3/A403	4/A403	-	E	(2) 3'-0" Doors
191B	New	7'-0"	7'-0"	HM	D3	-	HM	F1	1/A403	2/A403	-	N	(2) 3'-6" Doors - 1 Hr Fire Rated
191C	New	3'-0"	7'-0"	SC WD	D3	DF-2	HM	F1	1/A403	2/A403	-	H	1 Hour Fire Rated
192	New	3'-0"	7'-0"	GL; SC WD	D2	DF-2	ALUM	F4	3/A403	4/A403	-	B	-
193	New	6'-0"	7'-0"	ALUM; GL	D2	DK Bronze	ALUM	X8	10/A301	13/A301	7/A301	E	(2) 3'-0" Doors
194	New	3'-0"	7'-0"	GL; SC WD	D2	DF-2	ALUM	F4	3/A403	4/A403	-	B	-
195	New	3'-0"	7'-0"	ALUM; GL	D2	DK Bronze	ALUM	X9	8/A302	11/A302	7/A301	C	-
197	New	5'-0"	7'-0"	-	-	-	-	-	-	-	-	-	Finished Opening
214	New	3'-0"	7'-0"	SC WD	D1	Reuse Exist.	ALUM	F1	3/A403	4/A403			

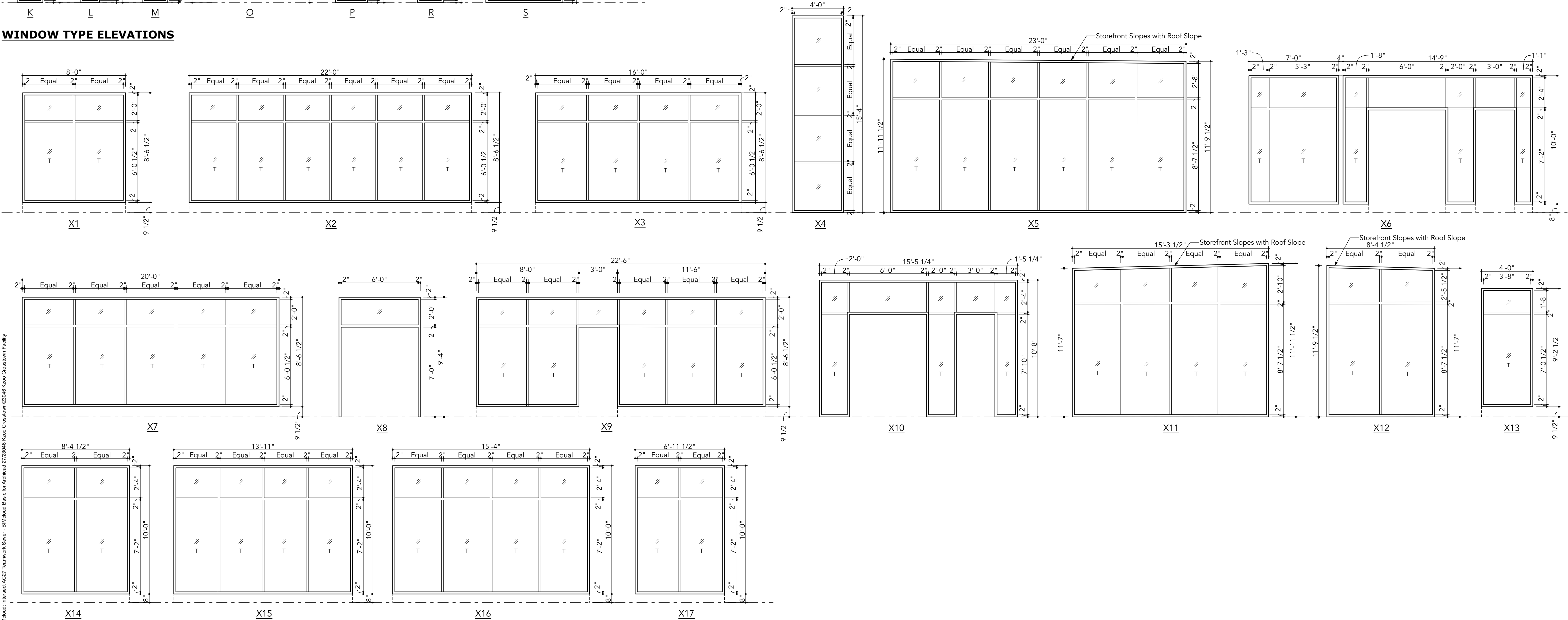
General Notes:

- Exterior Aluminum Storefront System - Basis of Design: Tubelite T14000
Finish: Champagne Anodized at New Entry Vestibule
Dark Bronze at other new openings / punched openings to match existing.
- Aluminum Interior Office Glazing / Borrowed Lites - Basis of Design: Tubelite E4500 - Clear Anodized Finish
- Sliding Door System - Basis of Design: Dormakaba Muto Comfort L80
- Solid Core Veneer Wood Doors - Basis of Design: VT Industries or equivalent - 1-3/4" thick.
- Re-key all lock cores in existing doors to remain. Coordinate with Owner's Locksmith.
- Paint all hollow metal door frames and doors. Repaint all existing hollow metal doors & frames to remain in area of work. See Exterior Elevations for exterior colors. Interior frames and doors - color to match adjacent wall unless noted otherwise.
- Elevator E-2 - repaint lobby side door & frame, PT-X.
- Repair or replace hardware on existing or salvaged doors as needed to bring to good working order and to match function as shown on door schedule.
- Bullet Resistant Assemblies shall meet requirements for Level 3 Bullet Resistance. See specifications.
- Exterior glazing: GL-1; Interior Glazing: GL-2.
Provide Tapered Glazing and Bullet Resistant Glazing as noted.

ID	UNIT SIZE	HEIGHT		FRAME		DETAIL			NOTE
		HEAD	SILL	MTRL	TYPE	HEAD	JAMB	SILL	
Main Level									
A	4'-0" x 4'-0"	7'-0"	3'-0"	ALUM	Fixed	-	-	-	
B	1'-6" x 4'-0"	8'-0"	4'-0"	ALUM	Fixed	8/A403	9/A403	7/A403	
C	3'-0" x 7'-2"	7'-2"	0"	ALUM	Fixed	8/A403	9/A403	7/A403	
D	10'-6" x 4'-0"	10'-0"	6'-0"	ALUM	Fixed	8/A403	9/A403	7/A403	
E	8'-0" x 4'-0"	7'-0"	3'-0"	ALUM	Fixed	-	-	-	
F	4'-0" x 7'-0"	7'-0"	0"	ALUM	Fixed	8/A403	9/A403	7/A403	
G	6'-0" x 3'-8"	7'-0"	3'-4"	HM	Fixed	11/A403	12/A403	10/A403	Bullet Resistant Assembly & Glazing - Level 3
H	6'-0" x 4'-2"	7'-0"	2'-10"	HM	Fixed	11/A403	12/A403	10/A403	Bullet Resistant Assembly & Glazing - Level 3
J	5'-0" x 7'-2"	7'-2"	0"	ALUM	Fixed	8/A403	9/A403	7/A403	
K	2'-0" x 8'-0"	8'-0"	0"	ALUM	Fixed	8/A403	9/A403	7/A403	
L	1'-6" x 8'-0"	8'-0"	0"	ALUM	Fixed	8/A403	9/A403	7/A403	
M	2'-0" x 9'-6"	9'-6"	0"	ALUM	Fixed	8/A403	9/A403	7/A403	
O	6'-10" x 4'-0"	7'-0"	3'-0"	ALUM	Fixed	8/A403	9/A403	7/A403	
P	2'-6" x 7'-0"	7'-0"	0"	ALUM	Fixed	8/A403	9/A403	7/A403	
R	2'-0" x 9'-0"	9'-0"	0"	ALUM	Fixed	8/A403	9/A403	7/A403	
S	6'-0" x 9'-6"	9'-6"	0"	ALUM	Fixed	8/A403	9/A403	7/A403	
Upper Level									
E	8'-0" x 4'-0"	7'-0"	3'-0"	ALUM	Fixed	8/A403	9/A403	7/A403	



WINDOW TYPE ELEVATIONS



EXTERIOR STOREFRONT ELEVATIONS

NOT FOR
REGULATORY
APPROVAL,
PERMITTING, OR
CONSTRUCTION

Bid Set 08/21/2025
Site Plan Review 07/31/2025
DD Set 07/03/2025
© 2025, Intersect studio, llc
Project Number: 23-046

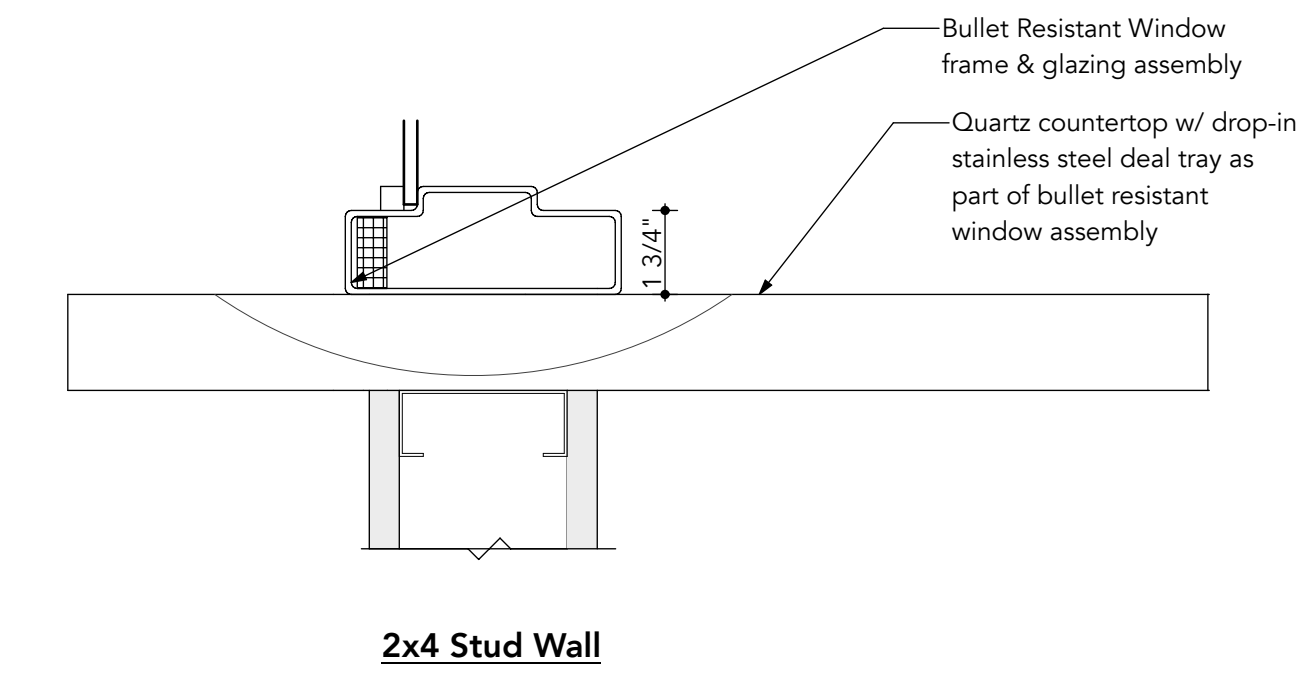
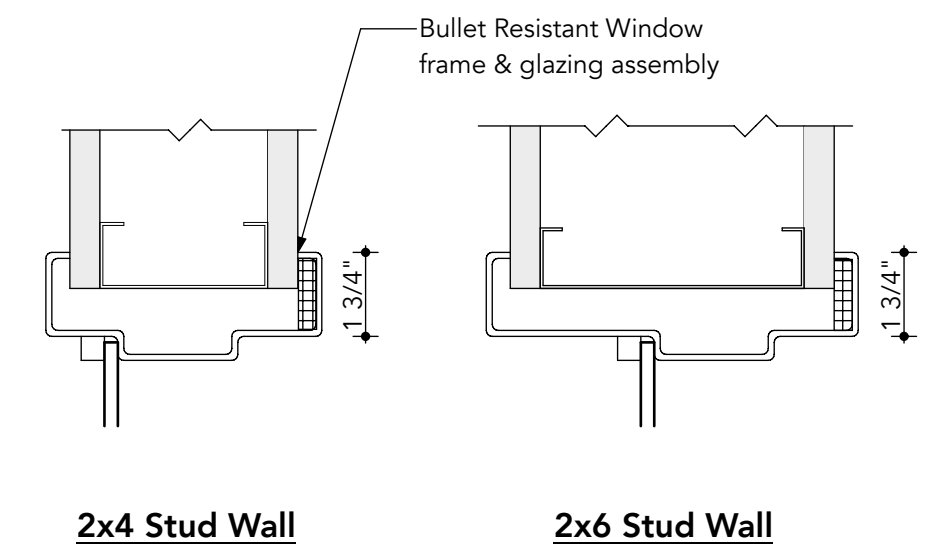
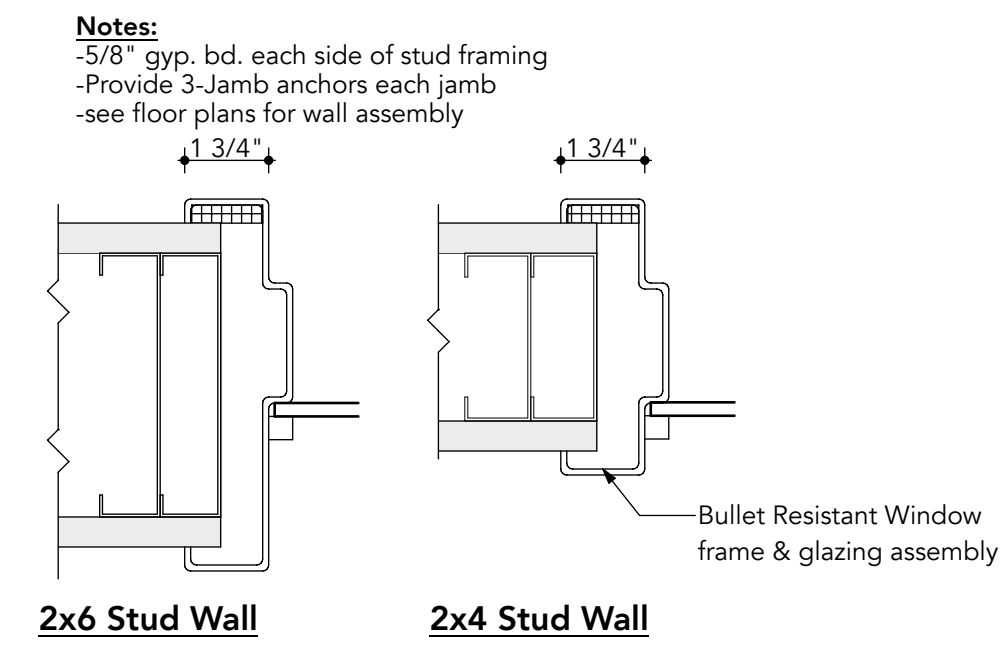
Window Schedule
& Details

NOT FOR
 REGULATORY
 APPROVAL,
 PERMITTING, OR
 CONSTRUCTION

Bid Set 08/21/2025
 Site Plan Review 07/31/2025
 DD Set 07/03/2025
 © 2025, intersect studio, llc
 Project Number: 23-046

Door and Window
 Details

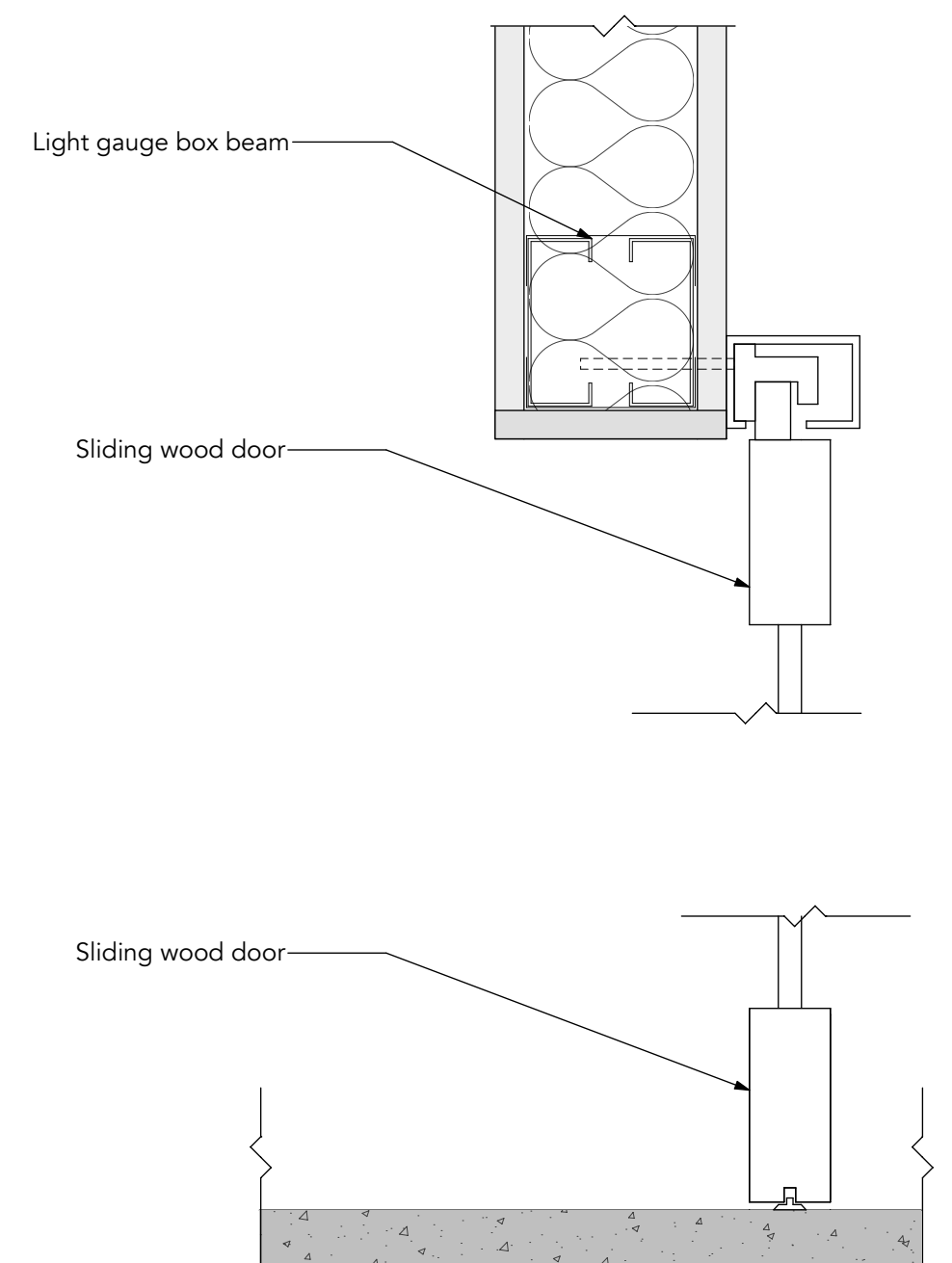
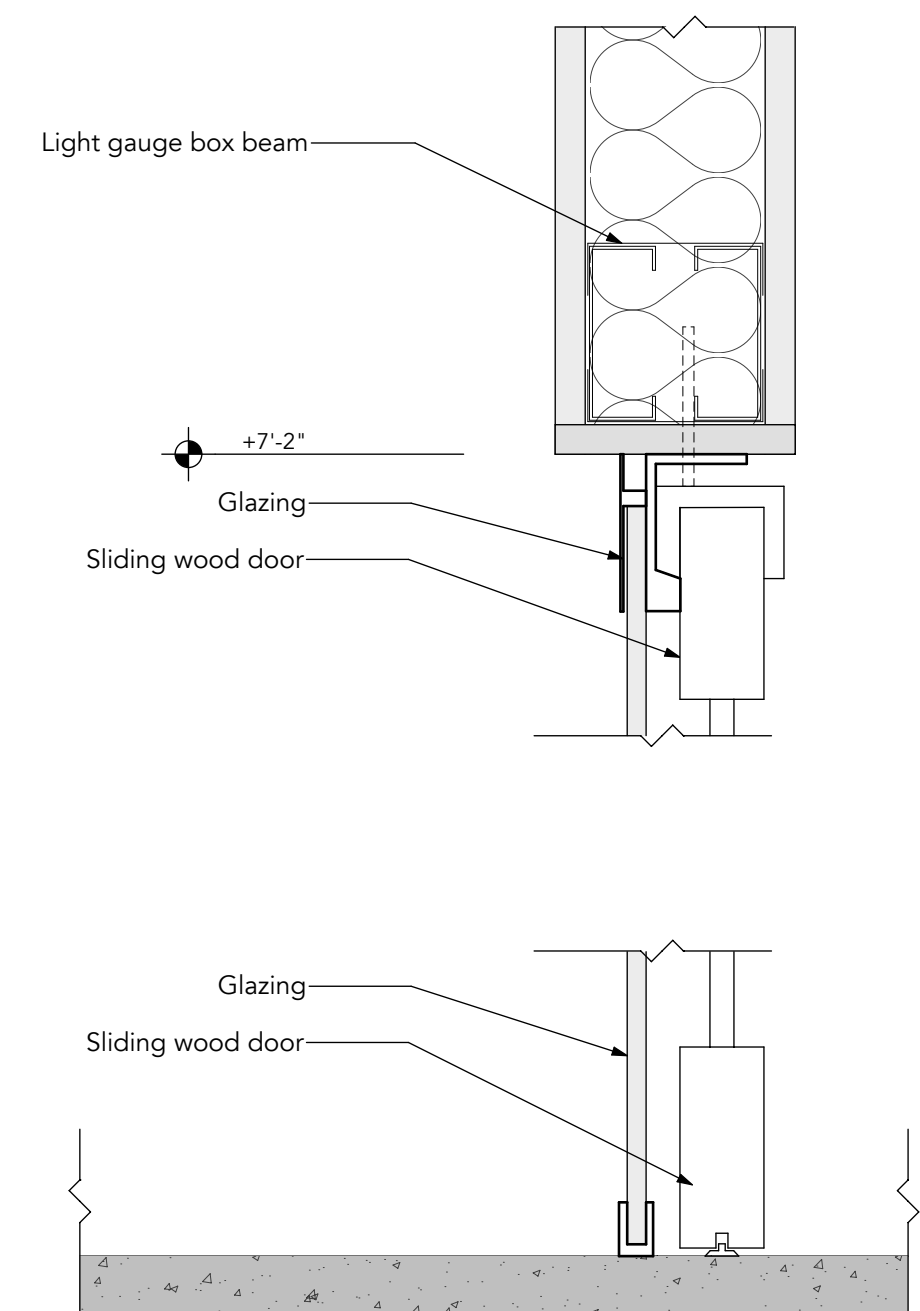
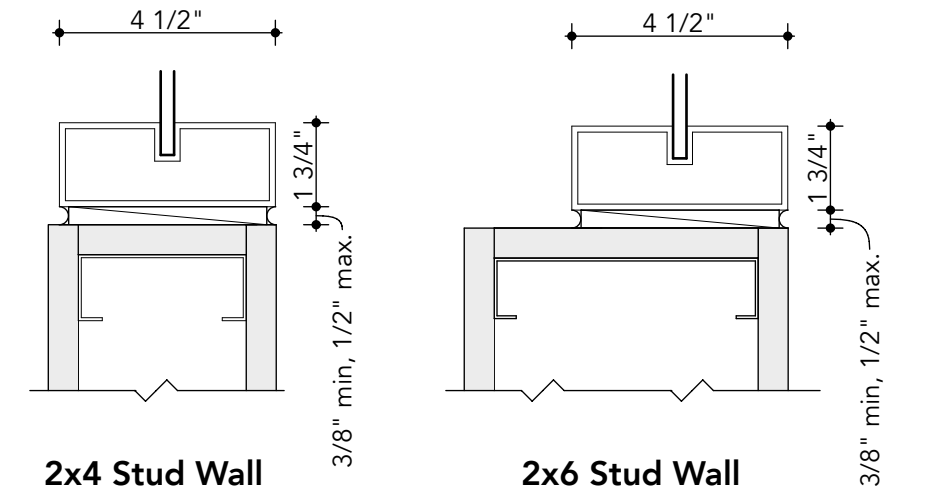
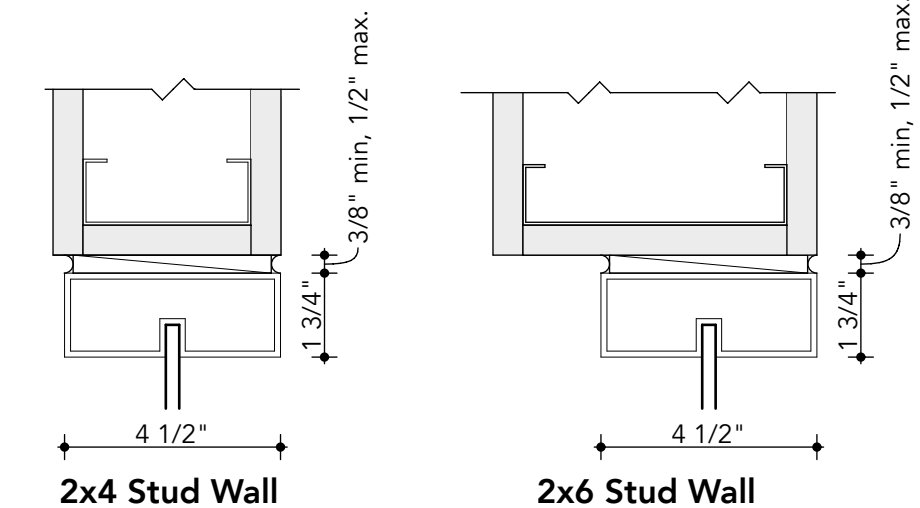
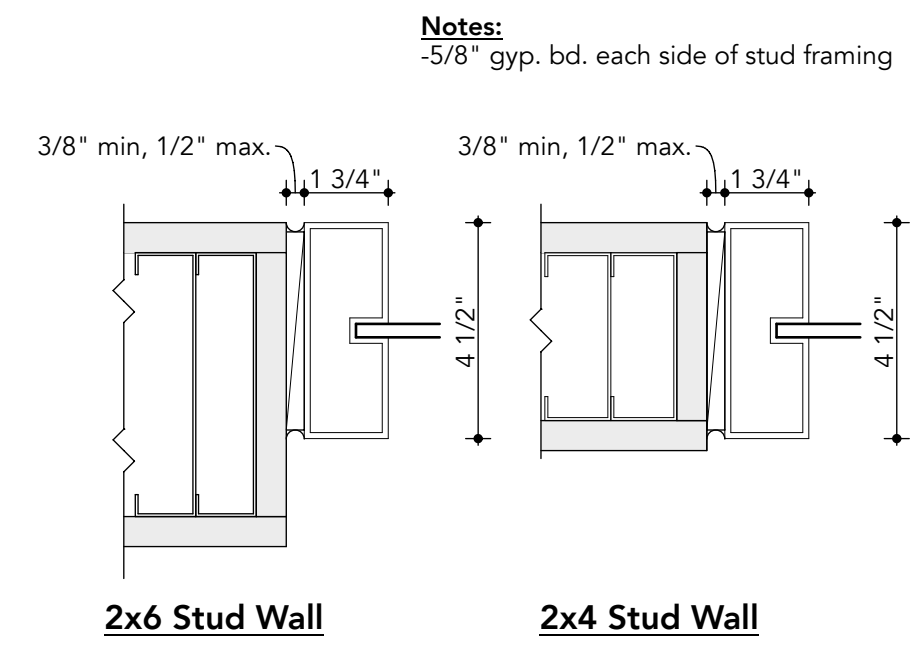
NOTE: See Floor Plans sheets for specific wall assembly information



12 Typical HM Window Jamb Interior
 A403 SCALE: 3" = 1'-0"

11 Typical HM Window Head Interior
 A403 SCALE: 3" = 1'-0"

10 Typical HM Window Sill Interior
 A403 SCALE: 3" = 1'-0"



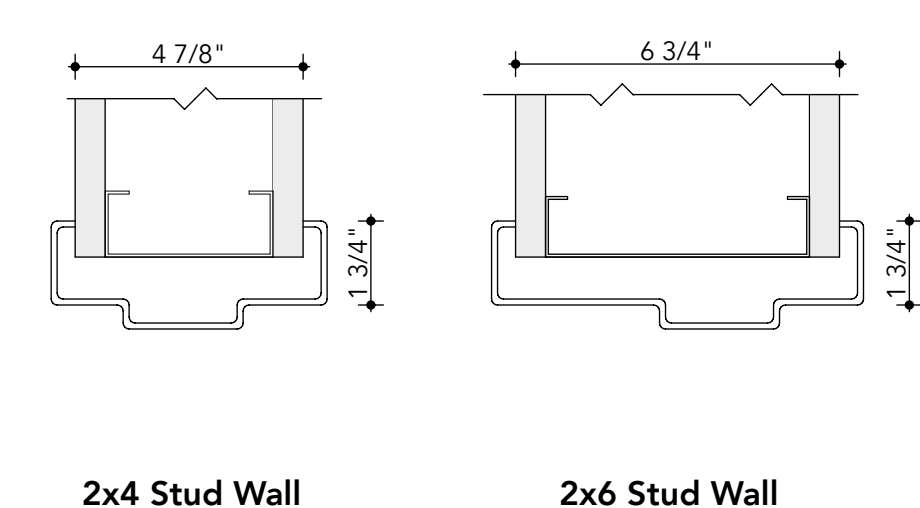
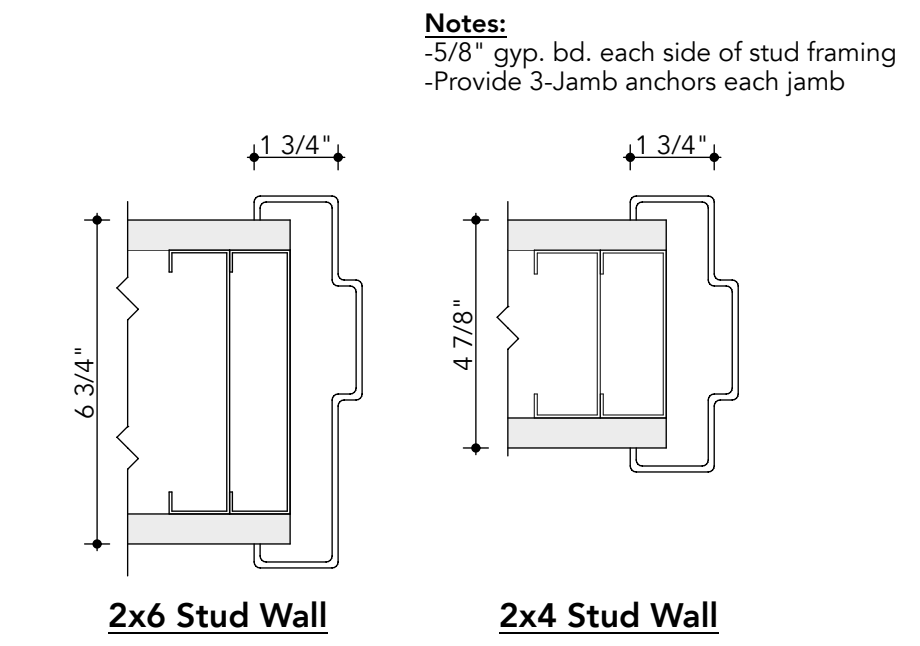
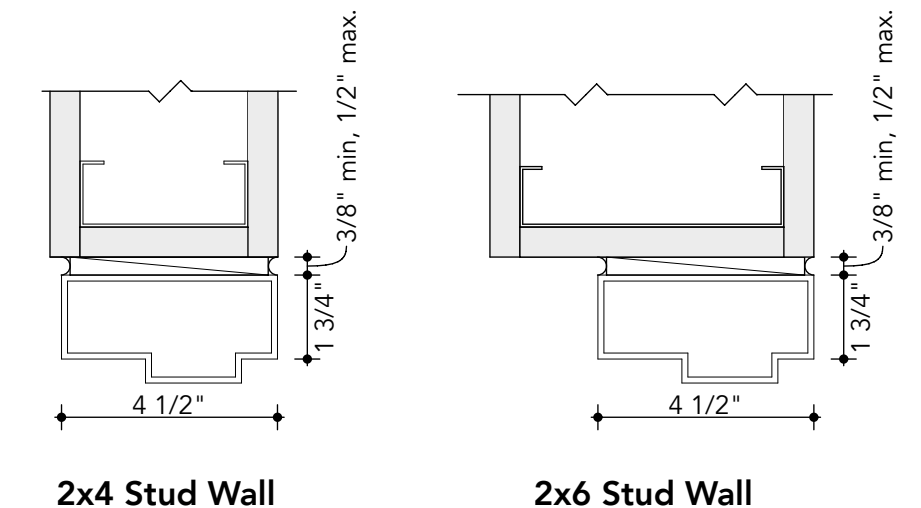
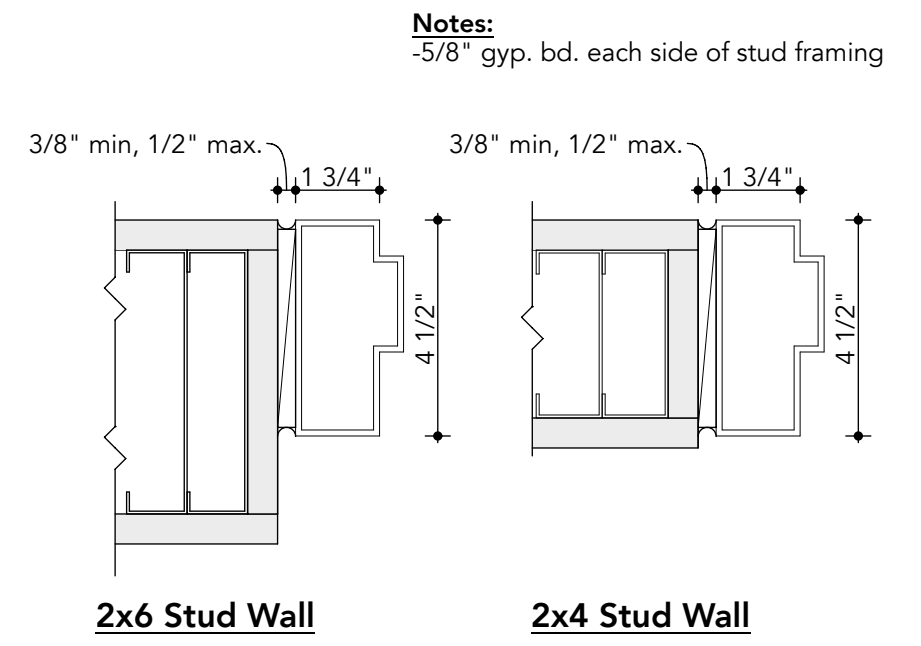
9 Typical Aluminum Window Jamb Interior
 A403 SCALE: 3" = 1'-0"

8 Typical Aluminum Window Head Interior
 A403 SCALE: 3" = 1'-0"

7 Typical Aluminum Window Sill Interior
 A403 SCALE: 3" = 1'-0"

6 Ceiling Mount Sliding Door Detail
 A403 SCALE: 3" = 1'-0"

5 Wall Mount Sliding Door Detail
 A403 SCALE: 3" = 1'-0"



4 Typical Aluminum Frame Jamb Interior
 A403 SCALE: 3" = 1'-0"

3 Typical Aluminum Frame Head Interior
 A403 SCALE: 3" = 1'-0"

2 Typical HM Frame Jamb Interior
 A403 SCALE: 3" = 1'-0"

1 Typical HM Frame Head Interior
 A403 SCALE: 3" = 1'-0"

9/8/25 - BIMcloud - Intersect - BIMcloud Basis for Archival 27/23/24 Koro Crosstown02046 Koro Crosstown Facility

NOT FOR
 REGULATORY
 APPROVAL,
 PERMITTING, OR
 CONSTRUCTION

Bid Set 08/21/2025
 Site Plan Review 07/31/2025
 DD Set 07/03/2025
 © 2025, intersect studio, llc
 Project Number: 23-046

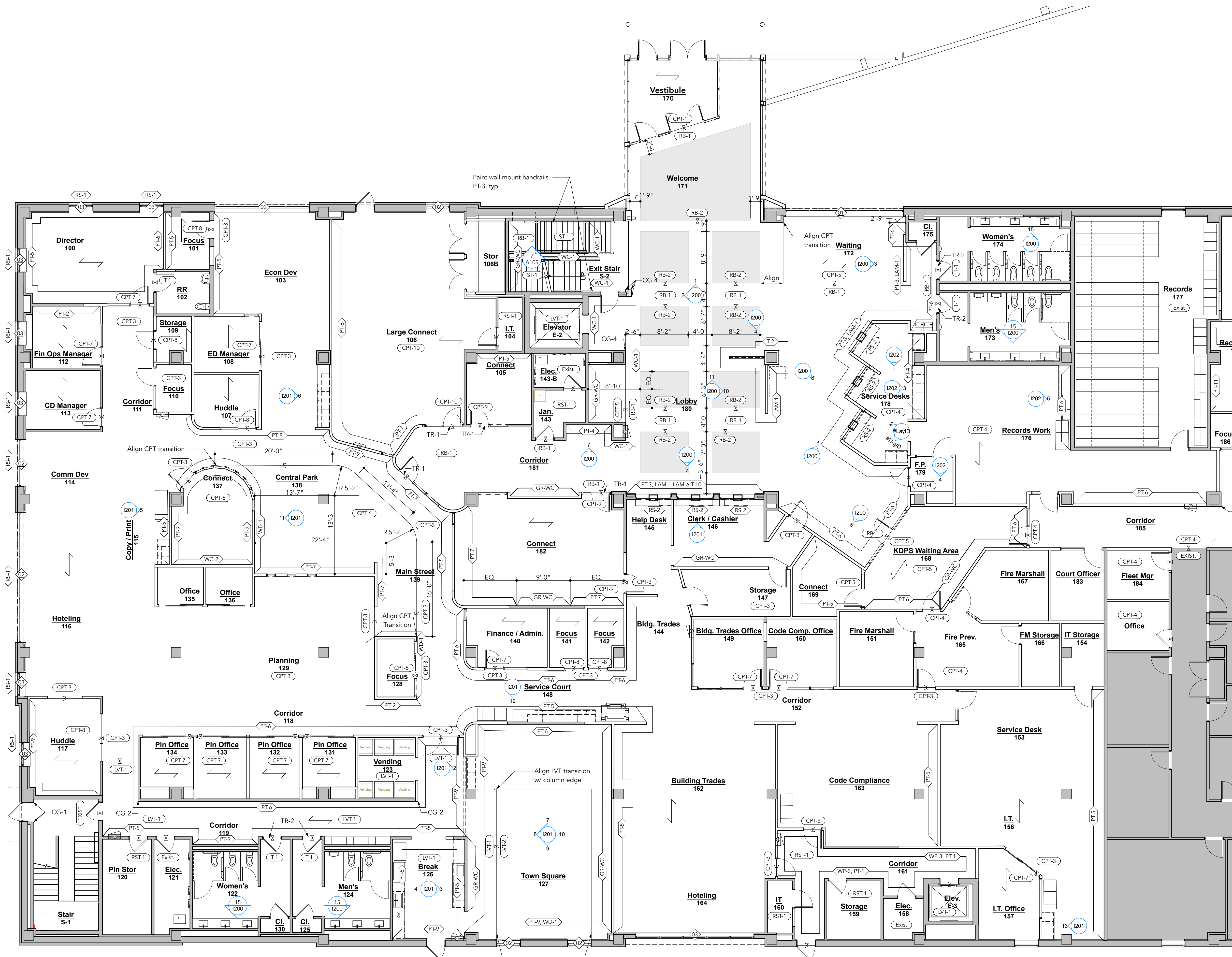
Finish Main Level
 Plan CPED

Finish Plan Notes

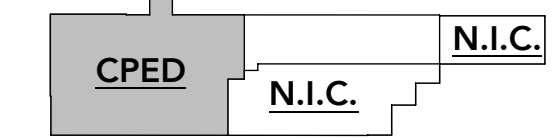
1. Paint to be applied to gyp. Bd. Surfaces only, unless otherwise noted.
2. Gyp. bd. walls to be painted field color (PT-1), unless otherwise noted.
3. Rubber wall base (RB-1) to be used on all gyp. bd. walls, unless otherwise noted.
4. CPED Field carpet tile (CPT-3) to be used in this area of the plan unless otherwise noted
5. See finish specifications schedule on sheet I401 and room schedule for additional notes and finish locations.

Finish Plan Keynotes

- QZ-1 Sill
- New melamine (LAM-8) sill w/ 2 1/2" high wood trim (WD-10) at wall face
- Existing PLAM sill- prep and paint PT-1



1
 1101 Finish Main Level Plan
 SCALE: 1/8" = 1'-0"



Key Plan - CPED

9/8/25 - BIMcloud - Intersect AC27 - Framework Server - BIMcloud Basis for Archival 27/25/24 Koro Crosstown Facility

Finish Plan Notes

1. Paint to be applied to gyp. Bd. Surfaces only, unless otherwise noted.
2. Gyp. bd. walls to be painted field color (PT-1), unless otherwise noted.
3. Rubber wall base (RB-1) to be used on all gyp. bd. walls, unless otherwise noted.
4. CPED Field carpet tile (CPT-3) to be used in this area of the plan unless otherwise noted
5. See finish specifications schedule on sheet I401 and room schedule for additional notes and finish locations.

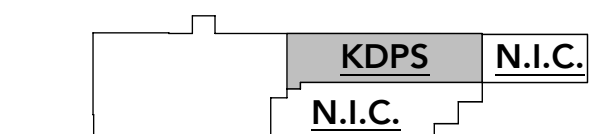
Finish Plan Keynotes

- QZ-1 Sill
- New melamine (LAM-8) sill w/ 2 1/2" high wood trim (WD-10) at wall face
- Existing PLAM sill- prep and paint PT-1

NOT FOR
 REGULATORY
 APPROVAL,
 PERMITTING, OR
 CONSTRUCTION

Bid Set 08/21/2025
 Site Plan Review 07/31/2025
 DD Set 07/03/2025
 © 2025, intersect studio, llc
 Project Number: 23-046

Finish Main Level
 Plan KDPS

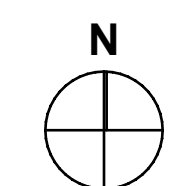


Key Plan - KDPS

1102



1 Finish Main Level Plan
 1102 SCALE: 1/8" = 1'-0"



9/8/25 - BIMcloud Intersect AC27 Framework Server - BIMcloud Basis for Archicad 27/2024 Koso Crosstown03046 Koso Crosstown Facility

NOT FOR
 REGULATORY
 APPROVAL,
 PERMITTING, OR
 CONSTRUCTION

Bid Set 08/21/2025
 Site Plan Review 07/31/2025
 DD Set 07/03/2025
 © 2025, intersect studio, llc
 Project Number: 23-046

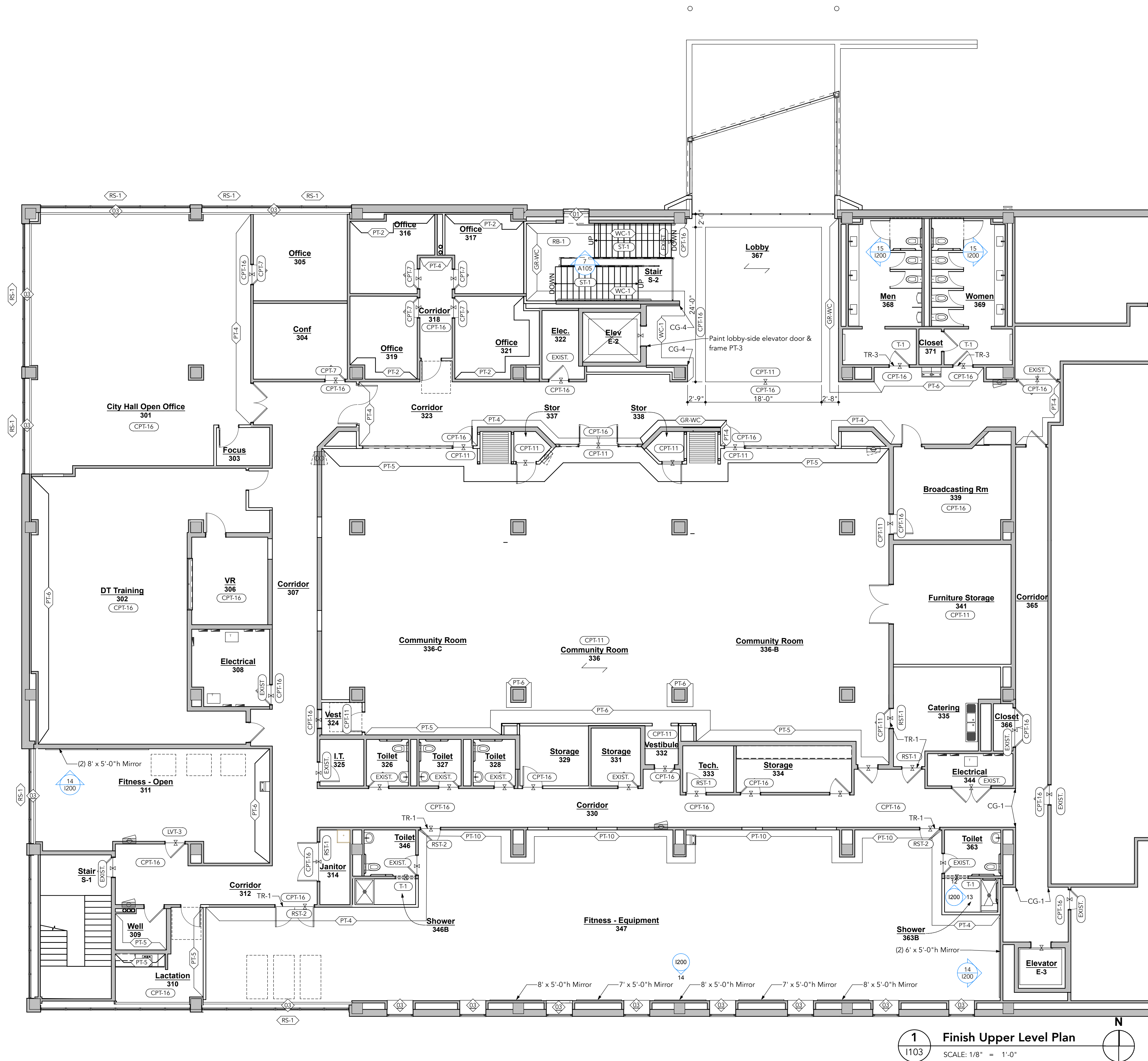
Finish Upper Level
 Plan CPED

Finish Plan Notes

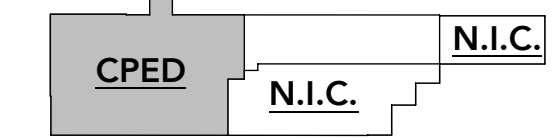
1. Paint to be applied to gyp. Bd. Surfaces only, unless otherwise noted.
2. Gyp. bd. walls to be painted field color (PT-1), unless otherwise noted.
3. Rubber wall base (RB-1) to be used on all gyp. bd. walls, unless otherwise noted.
4. CPED Field carpet tile (CPT-3) to be used in this area of the plan unless otherwise noted
5. See finish specifications schedule on sheet I401 and room schedule for additional notes and finish locations.

Finish Plan Keynotes

- QZ-1 Sill
- New melamine (LAM-8) sill w/ 2 1/2" high wood trim (WD-10) at wall face
- Existing PLAM sill- prep and paint PT-1



1 Finish Upper Level Plan
 1103 SCALE: 1/8" = 1'-0"



Key Plan - CPED

9/8/25 - BIMcloud - Intersect AC27 - Framework Server - BIMcloud Basis for Archival 27/23/24 Koro Crosstown02046 Koro Crosstown Facility

Furniture Plan Notes

1. Furniture Plans are schematic and for reference only.



City of Kalamazoo - Crosstown Facility
 CPED & KDPS Workplace Renovation
 150 E Crosstown Parkway Kalamazoo MI 49001

NOT FOR
 REGULATORY
 APPROVAL,
 PERMITTING, OR
 CONSTRUCTION

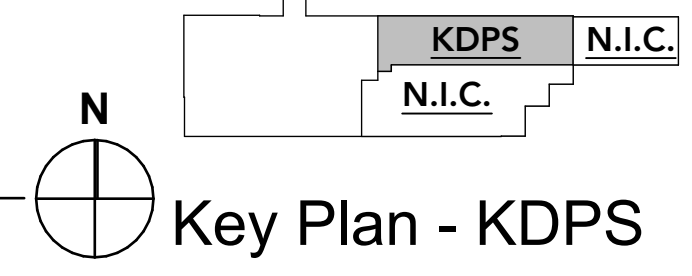
Bid Set 08/21/2025
 Site Plan Review 07/31/2025
 DD Set 07/03/2025
 © 2025, intersect studio, llc
 Project Number: 23-046

Furniture Main
 Level Plan KDPS

1105



2 Furniture Main Level Plan
 1105 SCALE: 1/8" = 1'-0"



8/25/25 - BIMcloud: Intersect AC27 Framework Server - BIMcloud Basic for Archival 27/25/25 KDPS Crosstown Facility

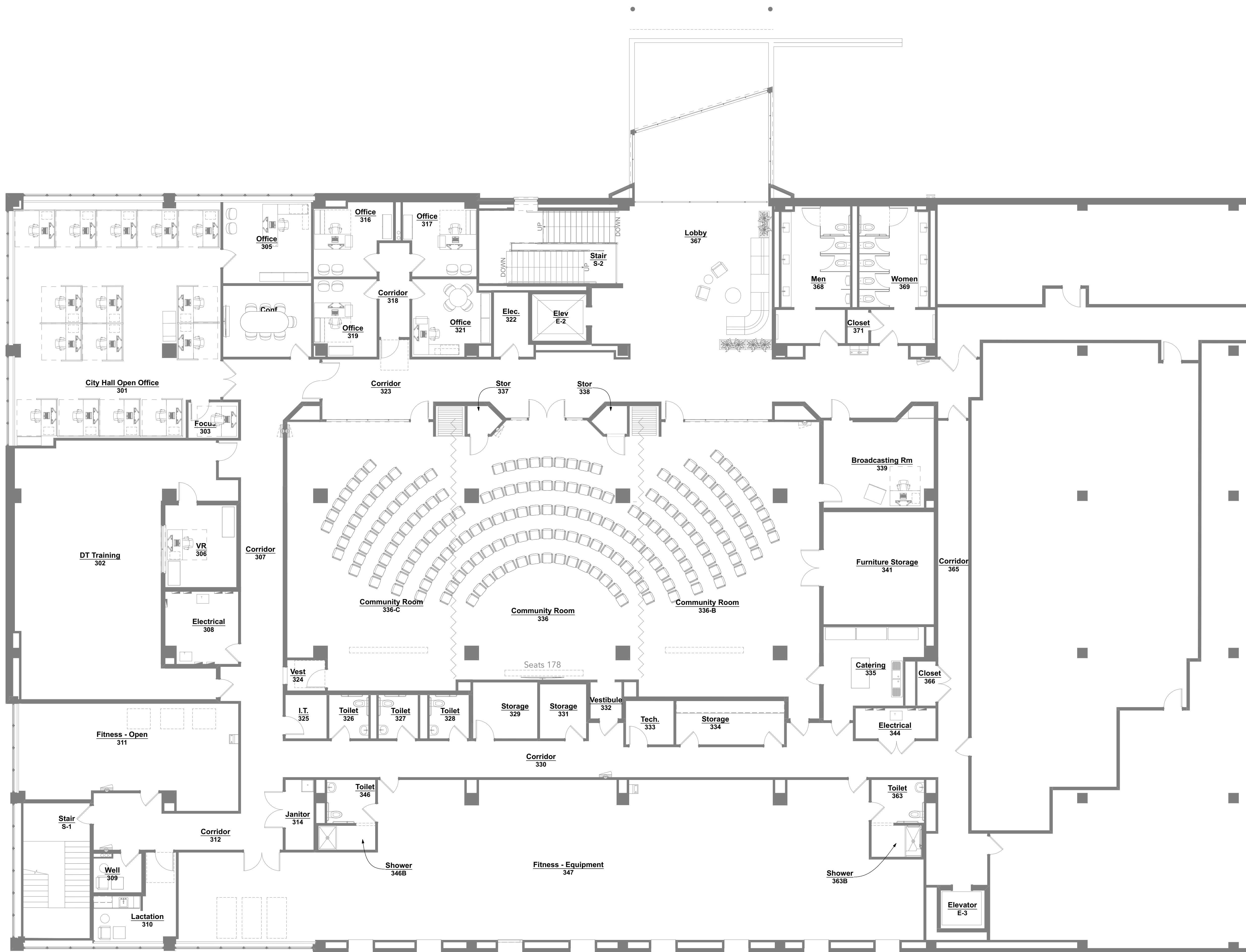
Furniture Plan Notes

1. Furniture Plans are schematic and for reference only.

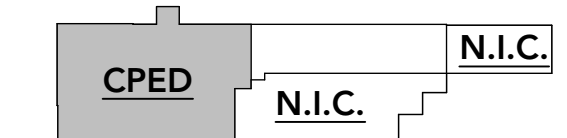
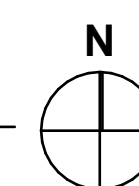
NOT FOR
 REGULATORY
 APPROVAL,
 PERMITTING, OR
 CONSTRUCTION

Bid Set 08/21/2025
 Site Plan Review 07/31/2025
 DD Set 07/03/2025
 © 2025, Intersect studio, llc
 Project Number: 23-046

Furniture Upper
 Level Plan CPED



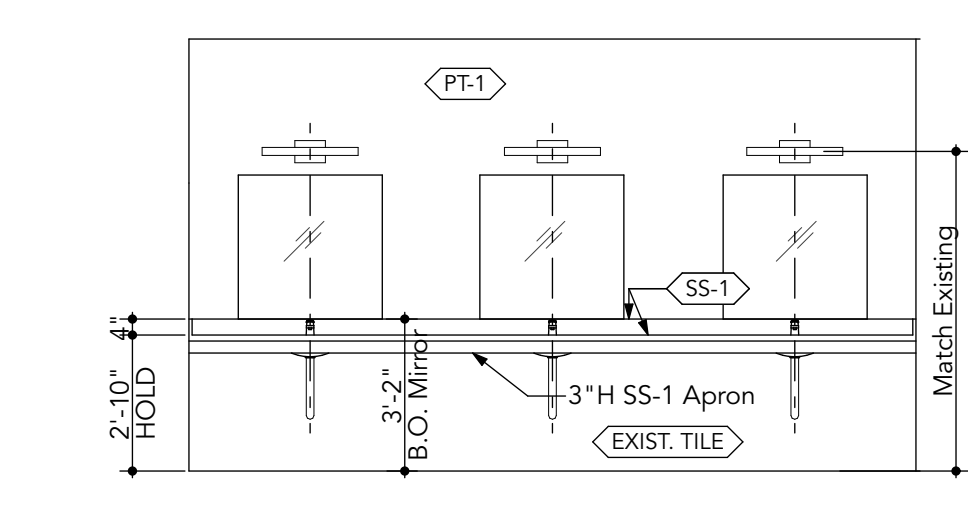
1 Furniture Upper Level Plan
 1106 SCALE: 1/8" = 1'-0"



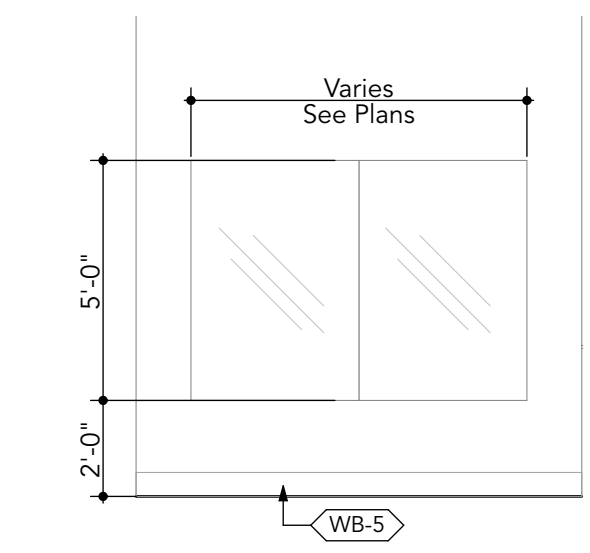
Key Plan - CPED

Interior Elevation Notes

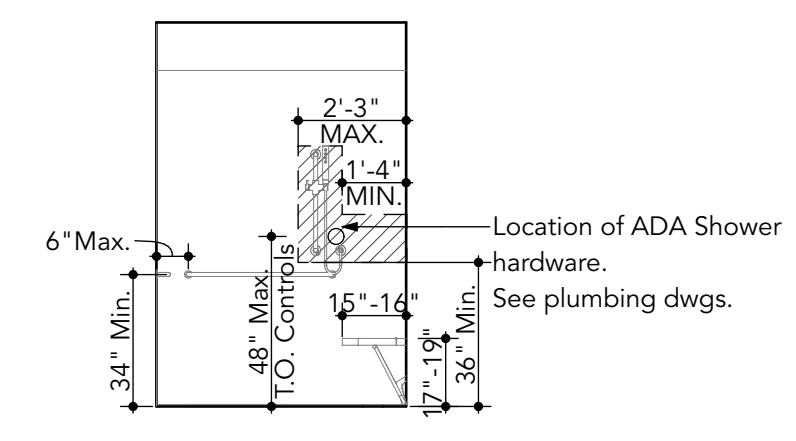
- See sheet I401 for finish specifications.
- All salvaged and relocated cabinetry to receive DP-1, coordinate size with existing hardware center to center dimension.
- All new casework to receive DP-2 unless otherwise noted.
- Appliances by owner, installed by contractor, typ.



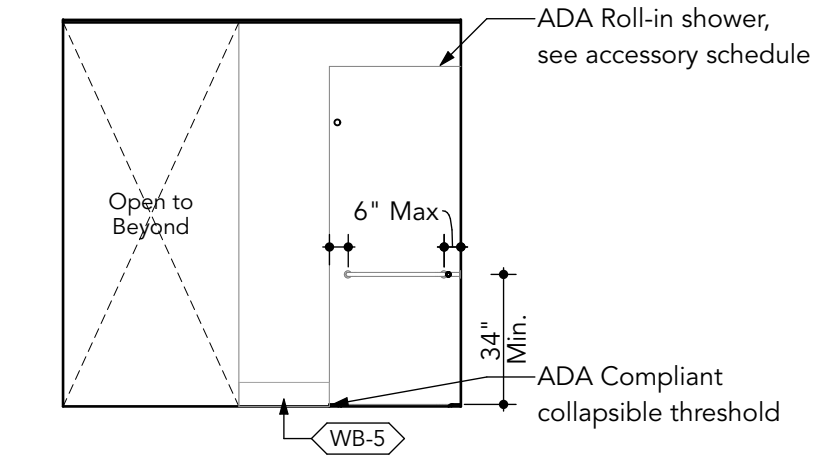
15 Multi-User Toilet Room Sinks, Typ.
I200 SCALE: 1/4" = 1'-0"



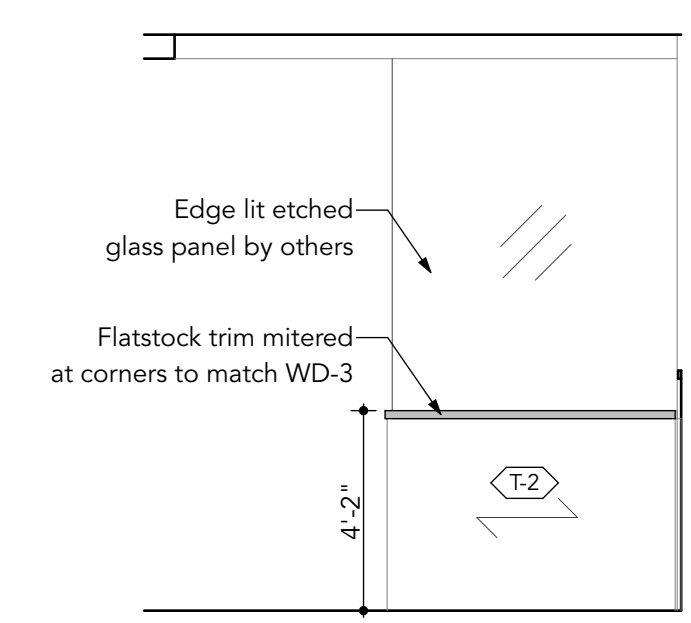
14 Fitness Mirror Elevation, Typ.
I200 SCALE: 1/4" = 1'-0"



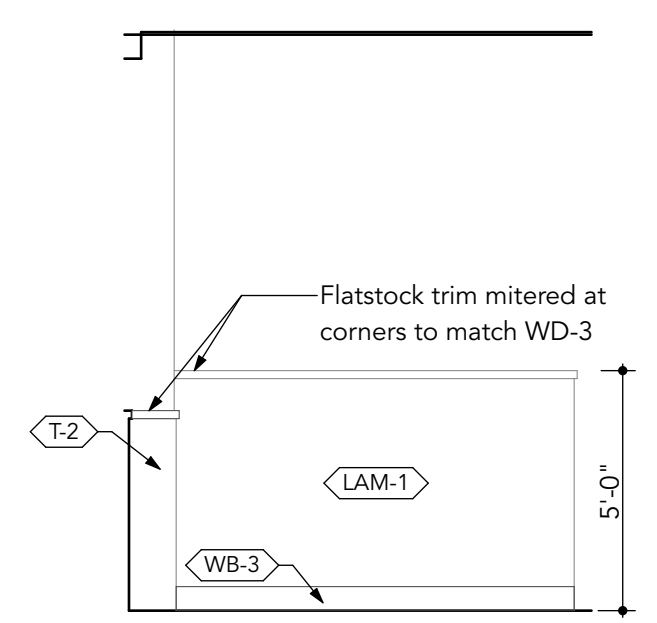
13 ADA Shower 363 East
I200 SCALE: 1/4" = 1'-0"



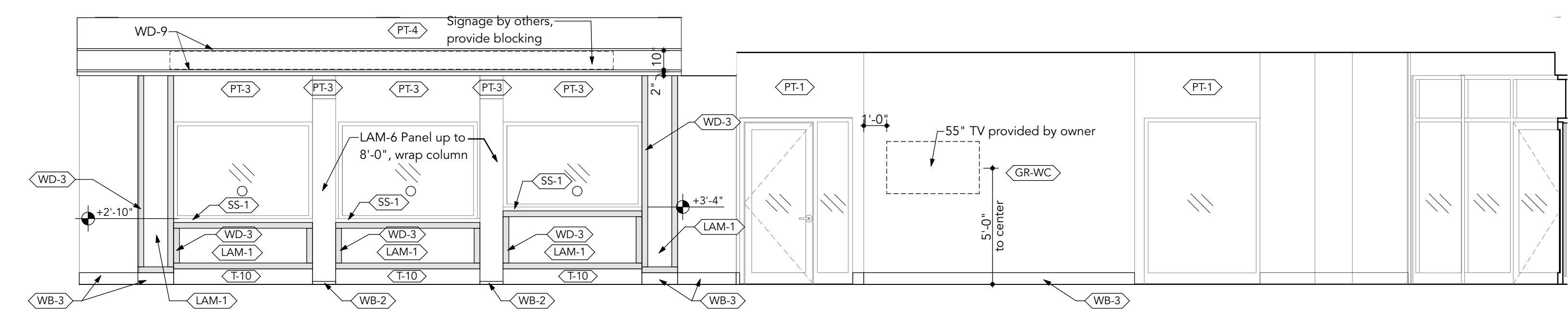
12 ADA Shower 363 North
I200 SCALE: 1/4" = 1'-0"



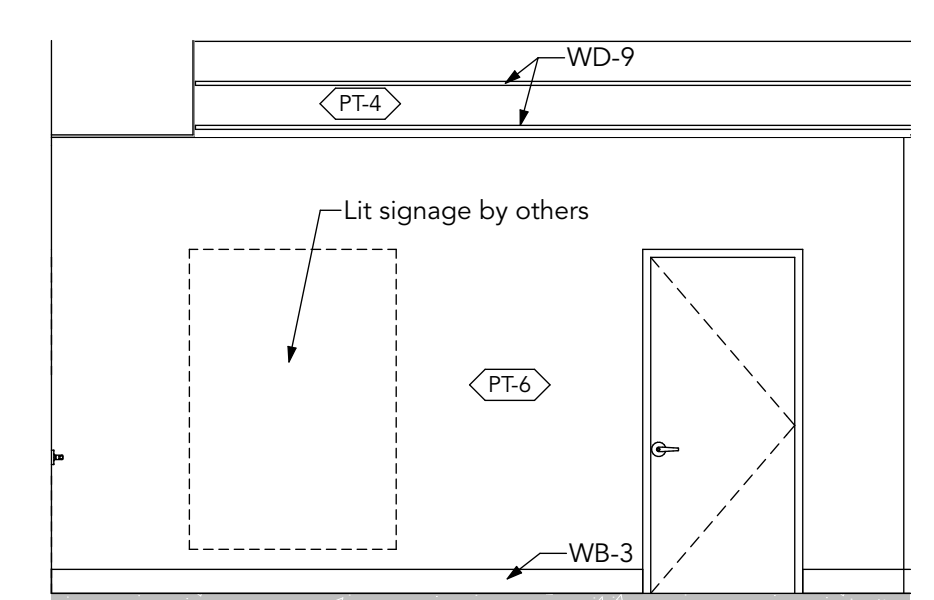
11 Waiting 180 North
I200 SCALE: 1/4" = 1'-0"



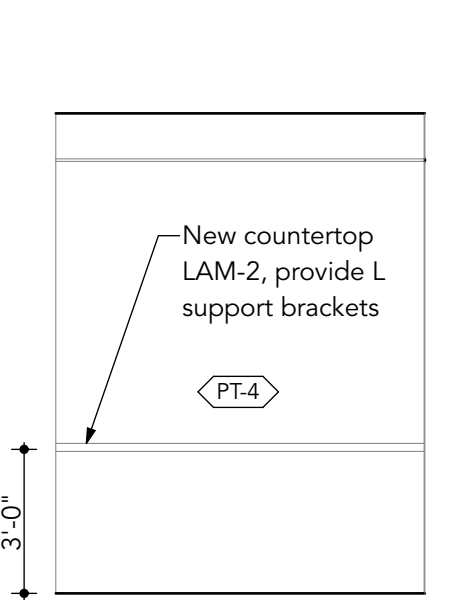
10 Waiting 180 East
I200 SCALE: 1/4" = 1'-0"



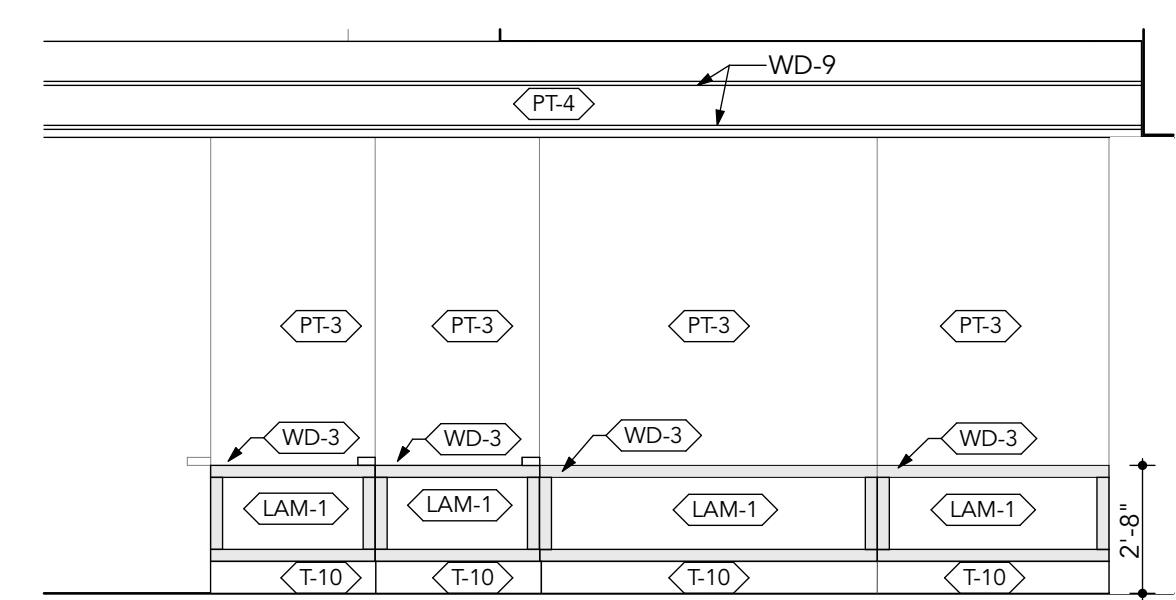
9 Waiting 180 South
I200 SCALE: 1/4" = 1'-0"



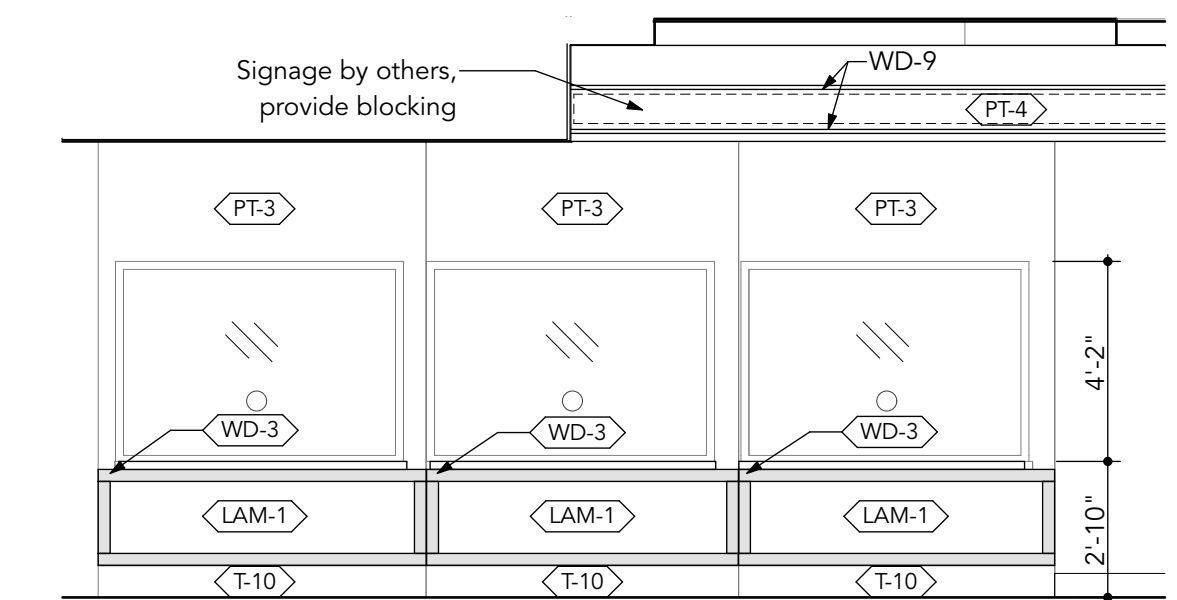
8 Clerk / Cashier Looking Southwest
I200 SCALE: 1/4" = 1'-0"



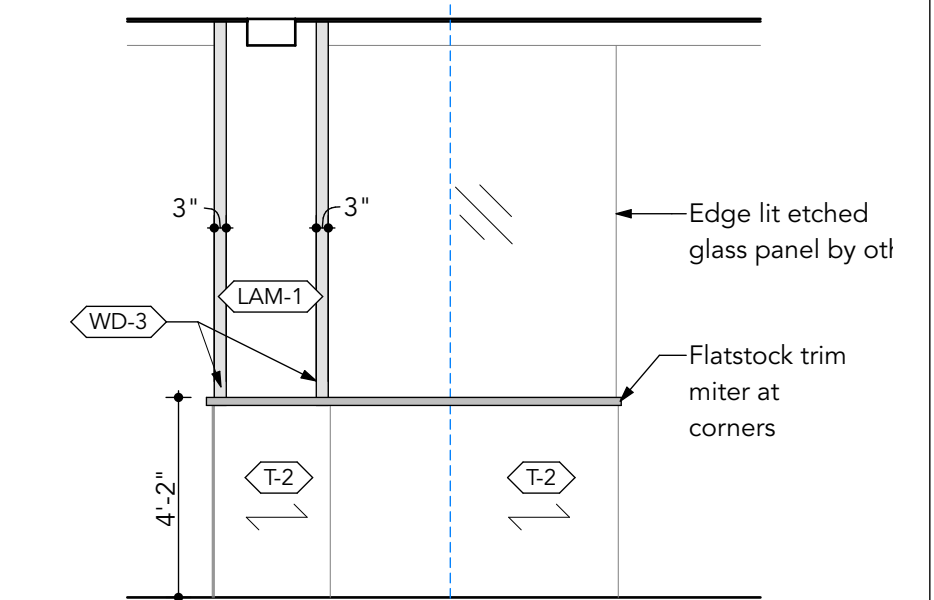
7 Corridor 181 North
I200 SCALE: 1/4" = 1'-0"



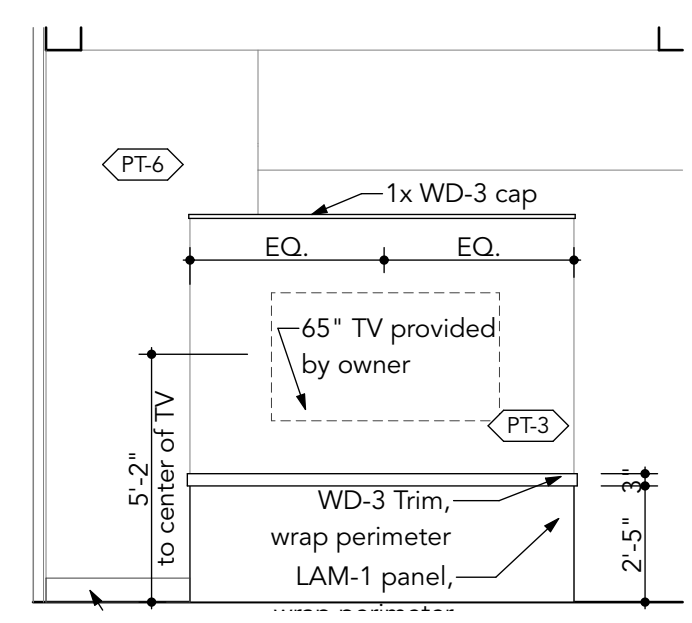
6 Waiting 172 Northeast
I200 SCALE: 1/4" = 1'-0"



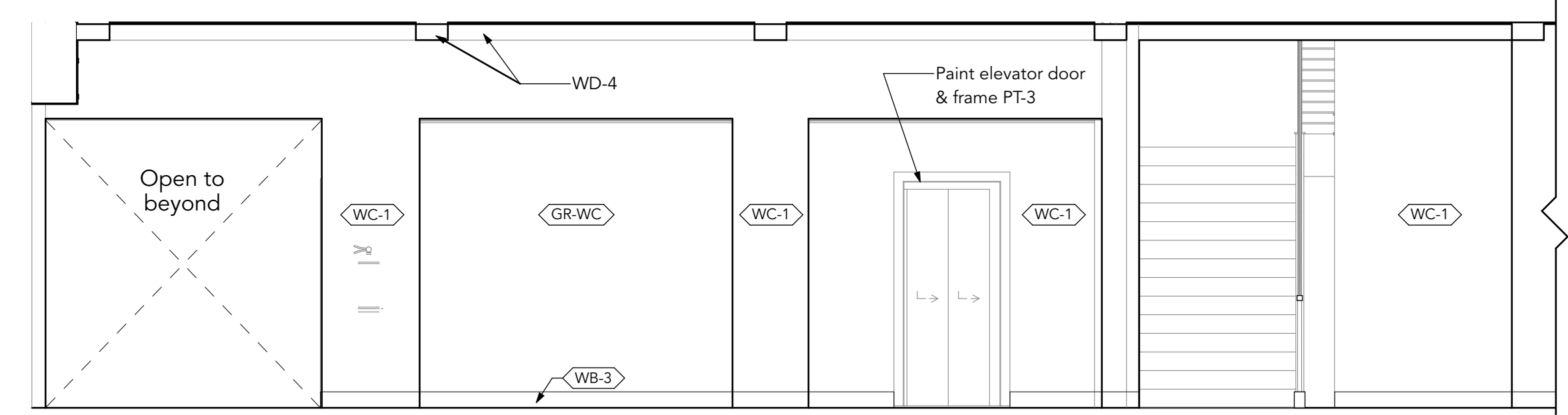
5 Waiting 172 Southeast
I200 SCALE: 1/4" = 1'-0"



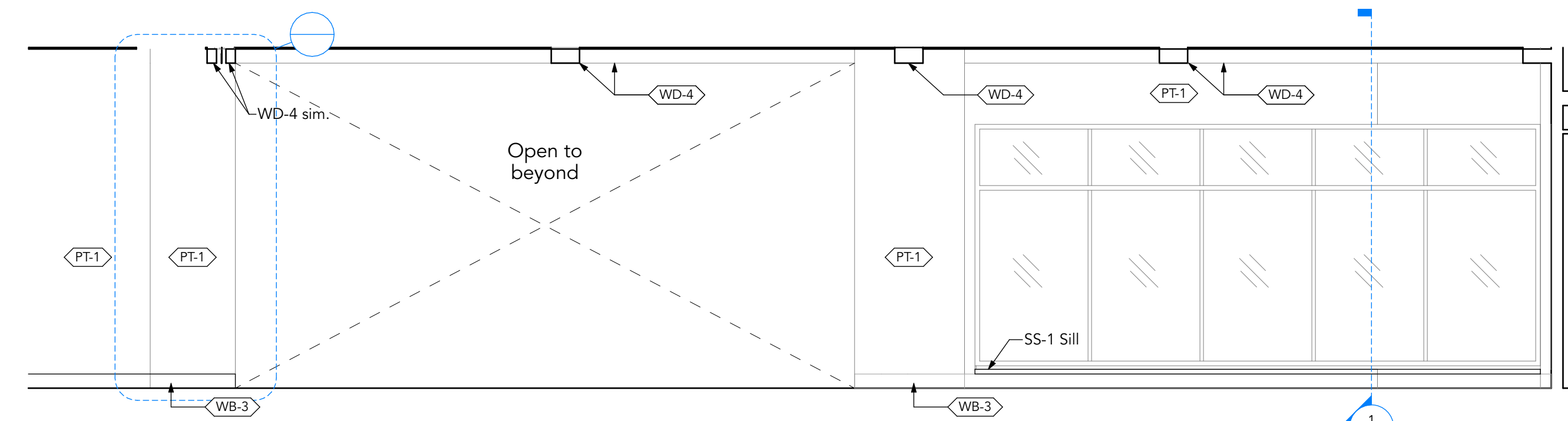
4 Waiting 172 South
I200 SCALE: 1/4" = 1'-0"



3 Waiting 172 East
I200 SCALE: 1/4" = 1'-0"



2 Welcome 171 West
I200 SCALE: 1/4" = 1'-0"



1 Welcome 171 North
I200 SCALE: 1/4" = 1'-0"

NOT FOR REGULATORY APPROVAL, PERMITTING, OR CONSTRUCTION

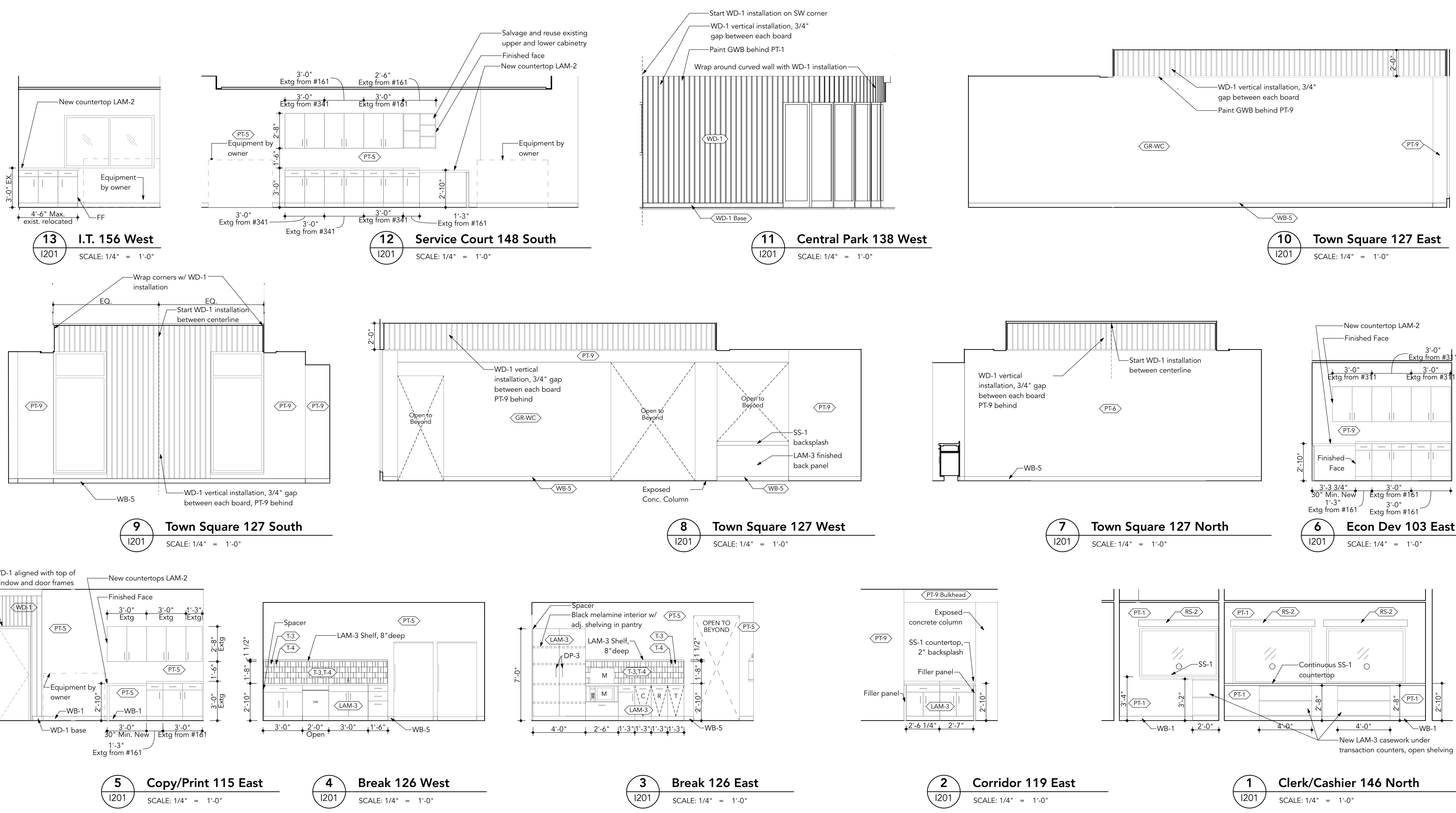
Bid Set 08/21/2025
Site Plan Review 07/31/2025
DD Set 07/03/2025
© 2025, intersect studio, llc
Project Number: 23-046

Interior Elevations

B1025 - BIMcloud; Intersect A327 Framework; Server - BIMcloud; Blotter for Archival 27252046 Koso Crosstown Facility

Interior Elevation Notes

1. See sheet I401 for finish specifications.
2. All salvaged and relocated cabinetry to receive DP-1, coordinate size with existing hardware center to center dimension.
3. All new casework to receive DP-2 unless otherwise noted.
4. Appliances by owner, installed by contractor, typ.



City of Kalamazoo - Crosstown Facility
 CPED & KDPS Workplace Renovation
 150 E Crosstown Parkway Kalamazoo MI 49001

NOT FOR
 REGULATORY
 APPROVAL,
 PERMITTING, OR
 CONSTRUCTION

Bid Set 08/21/2025
 Site Plan Review 07/31/2025
 DD Set 07/03/2025
 © 2025, intersect studio, llc
 Project Number: 23-046

Interior Elevations
 - CPED

8/6/25 - BIMcloud: Intersect AC27 Framework Server - BIMcloud Backup for Archival 27/25/2024 Koro Crosstown Facility

Interior Elevation Notes

- See sheet I401 for finish specifications.
- All salvaged and relocated cabinetry to receive DP-1, coordinate size with existing hardware center to center dimension.
- All new casework to receive DP-2 unless otherwise noted.
- Appliances by owner, installed by contractor, typ.

25 Day Room 263 East
I202 SCALE: 1/4" = 1'-0"

24 Day Room 263 South
I202 SCALE: 1/4" = 1'-0"

23 Day Room 263 West
I202 SCALE: 1/4" = 1'-0"

22 Day Room 263 North
I202 SCALE: 1/4" = 1'-0"

21 Recharge 260 East
I202 SCALE: 1/4" = 1'-0"

20 Recharge 260 South
I202 SCALE: 1/4" = 1'-0"

19 Recharge 260 West
I202 SCALE: 1/4" = 1'-0"

18 Work 262 South
I202 SCALE: 1/4" = 1'-0"

17 Report 261 East
I202 SCALE: 1/4" = 1'-0"

16 Report 261 South
I202 SCALE: 1/4" = 1'-0"

15 Report 261 West
I202 SCALE: 1/4" = 1'-0"

14 Corridor 214 South
I202 SCALE: 1/4" = 1'-0"

13 Kitchen 197 East
I202 SCALE: 1/4" = 1'-0"

12 Kitchen 197 West
I202 SCALE: 1/4" = 1'-0"

11 Work Cafe 195 South
I202 SCALE: 1/4" = 1'-0"

10 Work Cafe 195 West
I202 SCALE: 1/4" = 1'-0"

9 Work Cafe 195 North
I202 SCALE: 1/4" = 1'-0"

8 Lobby 191 South
I202 SCALE: 1/4" = 1'-0"

7 Lobby 191 West
I202 SCALE: 1/4" = 1'-0"

6 Linen 190 South
I202 SCALE: 1/4" = 1'-0"

5 Record 176 East
I202 SCALE: 1/4" = 1'-0"

4 F.P. 179 South
I202 SCALE: 1/4" = 1'-0"

3 Teleserve 176 East
I202 SCALE: 1/4" = 1'-0"

2 Teleserve 176 Northwest
I202 SCALE: 1/4" = 1'-0"

1 Teleserve 176 Southwest
I202 SCALE: 1/4" = 1'-0"

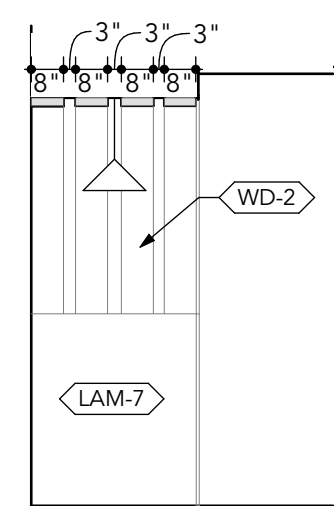
NOT FOR
REGULATORY
APPROVAL,
PERMITTING, OR
CONSTRUCTION

Bid Set 08/21/2025
Site Plan Review 07/31/2025
DD Set 07/03/2025
© 2025, Intersect Studio, LLC
Project Number: 23-046

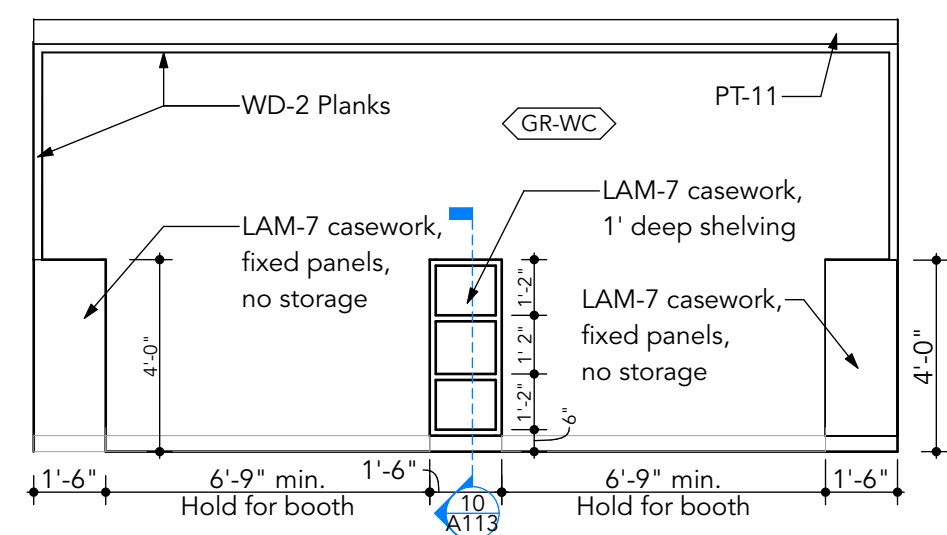
Interior Elevations
- KDPS

94925 - BIMcloud: Intersect AC27 Network Server - BIMcloud Backup for Archival 27/25/2024 Koro Crosstown Facility

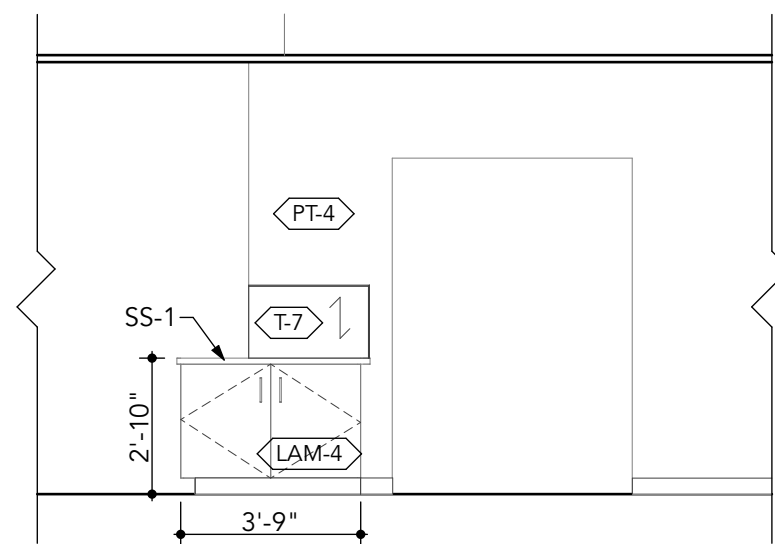
98255 - BIMcloud: Intersect AC27 Framework: Server - BIMcloud: Intersect AC27 Framework: Koso, Crosstown Facility



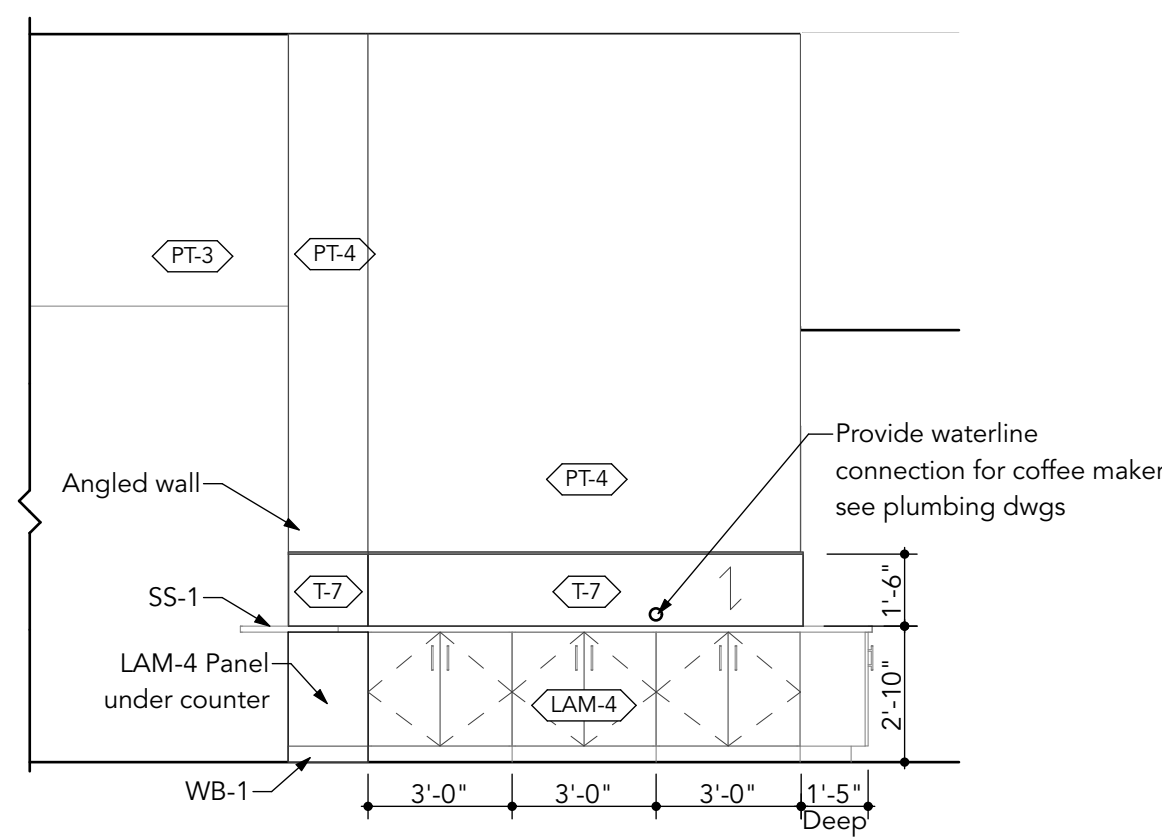
5 Corridor Looking West
1203 SCALE: 1/4" = 1'-0"



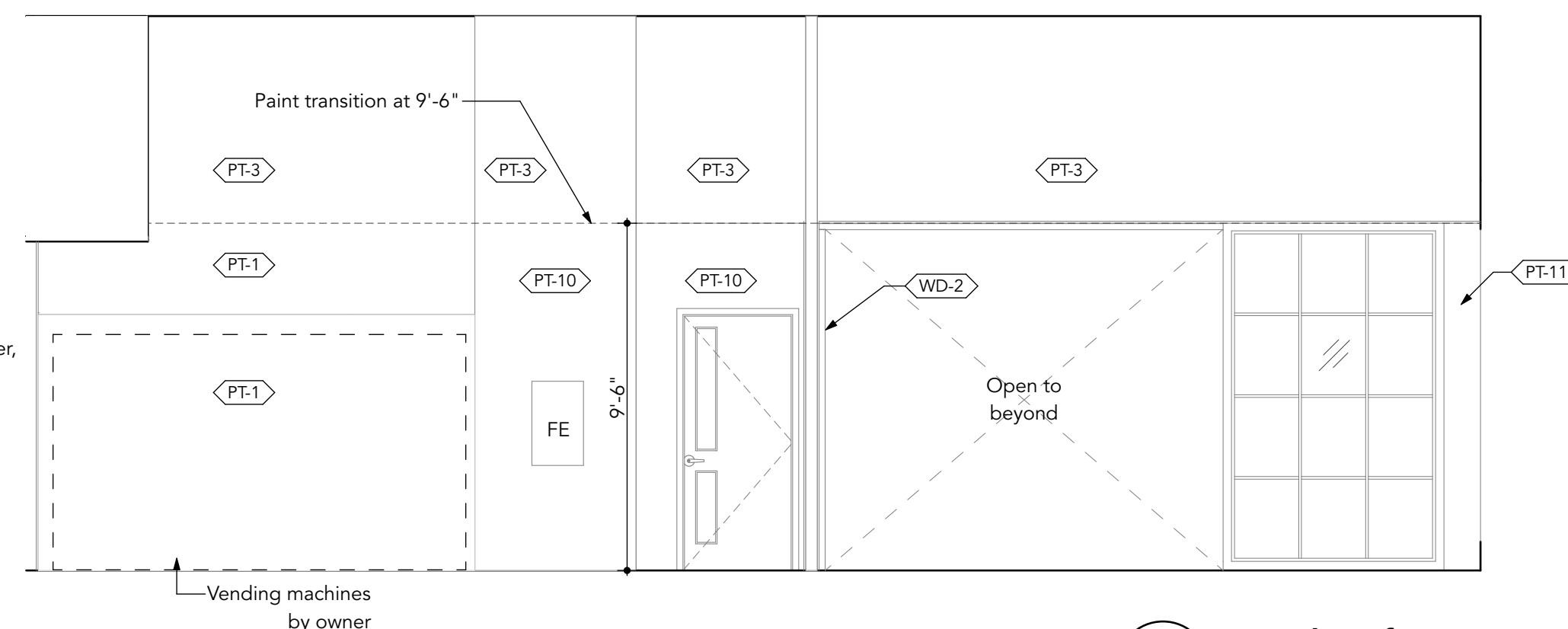
4 Corridor 196 South
1203 SCALE: 1/4" = 1'-0"



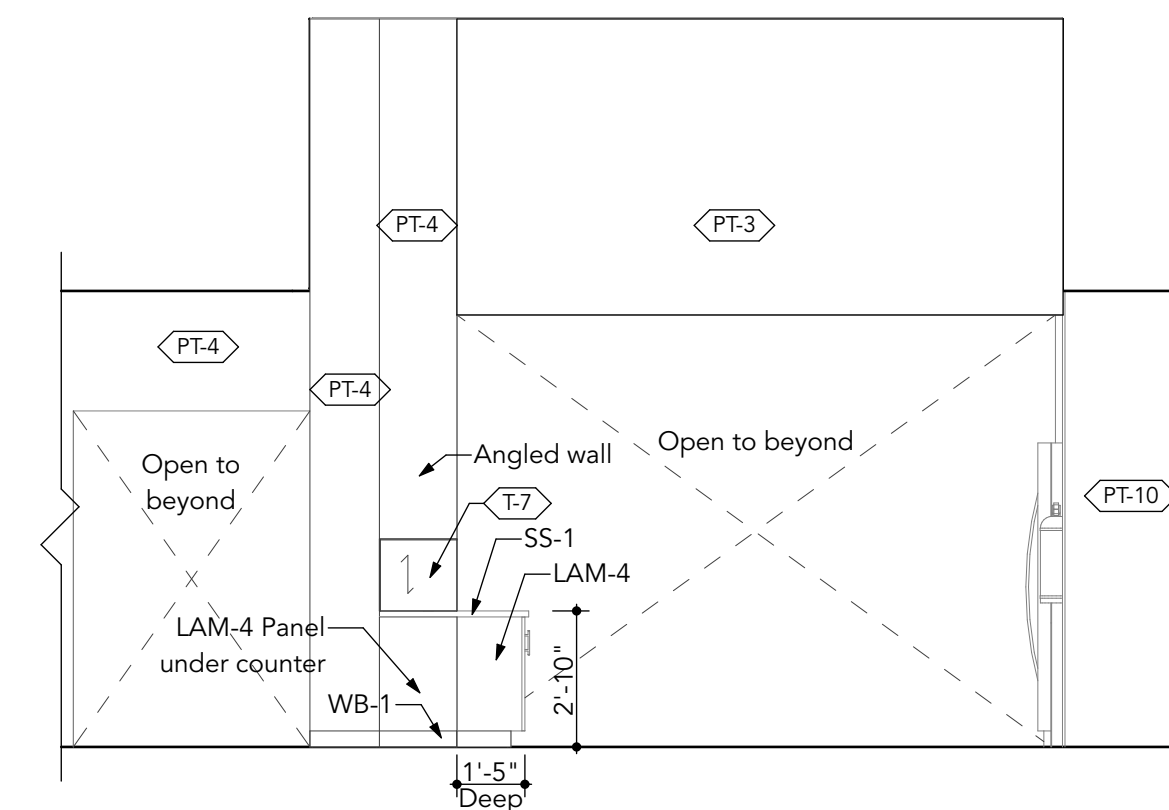
3 Work Cafe 195 North
1203 SCALE: 1/4" = 1'-0"



2 Work Cafe 195 East
1203 SCALE: 1/4" = 1'-0"



1 Work Cafe 195 West
1203 SCALE: 1/4" = 1'-0"

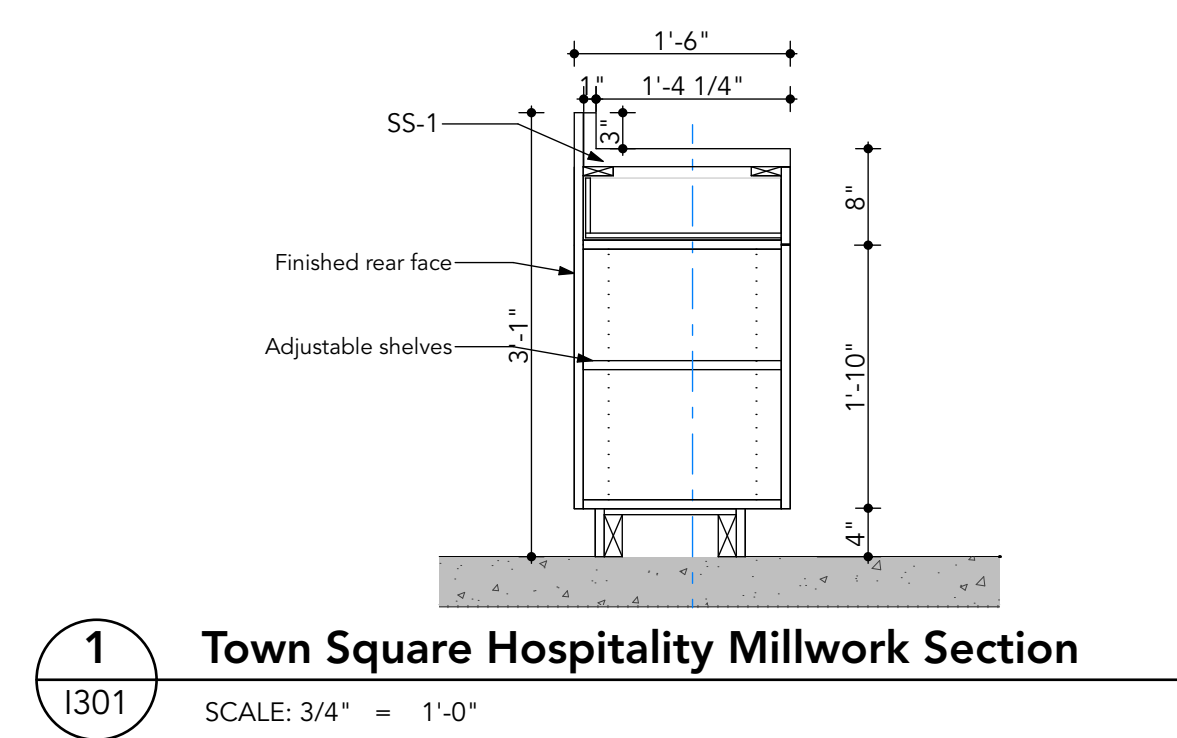
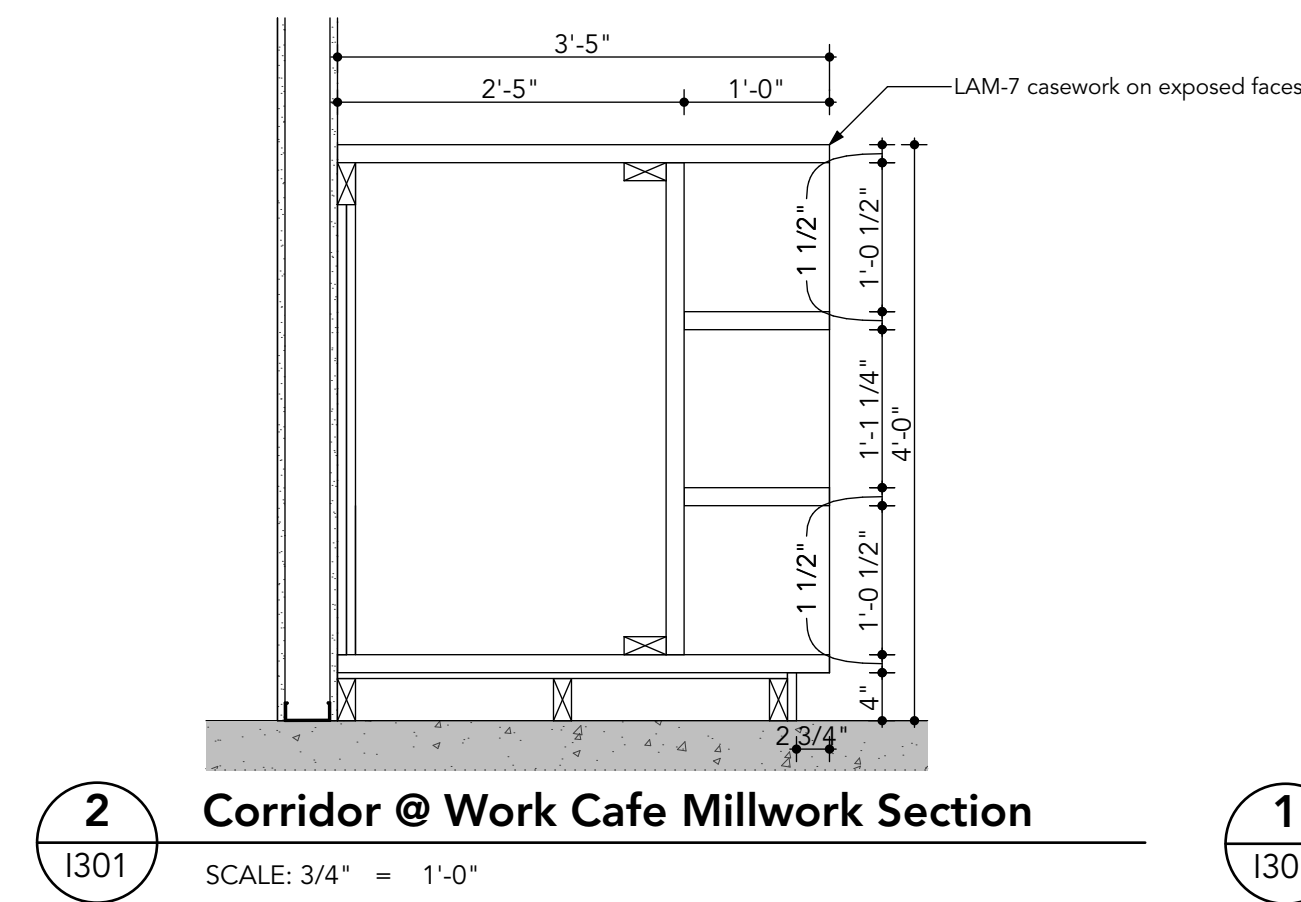
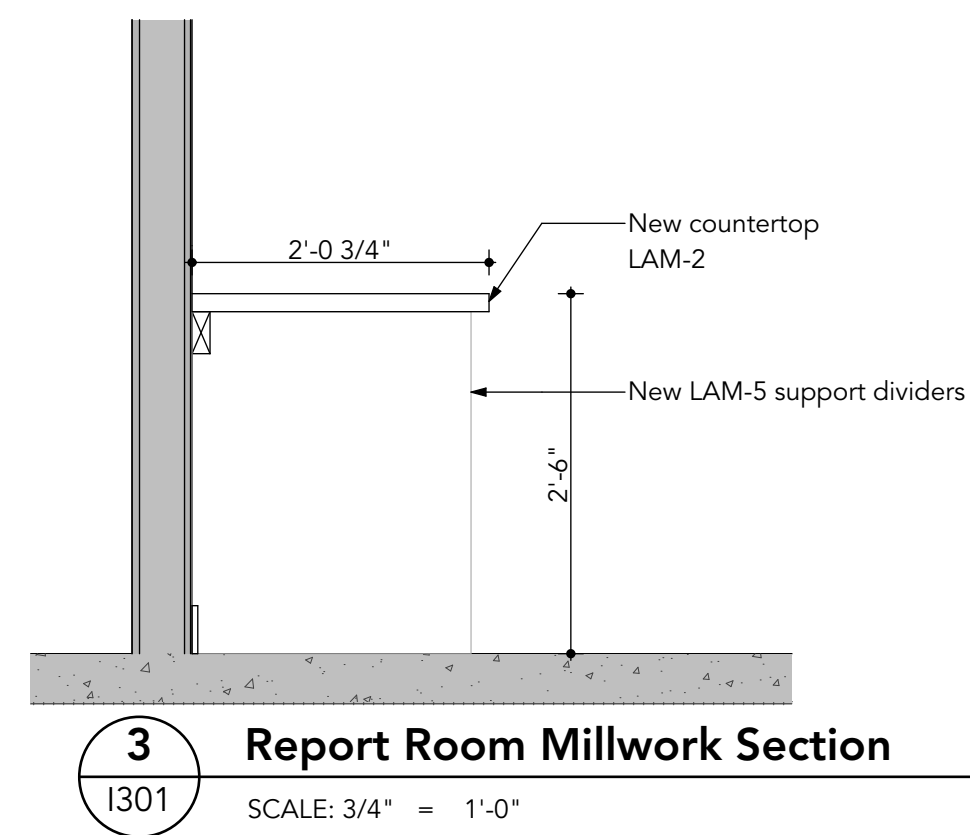
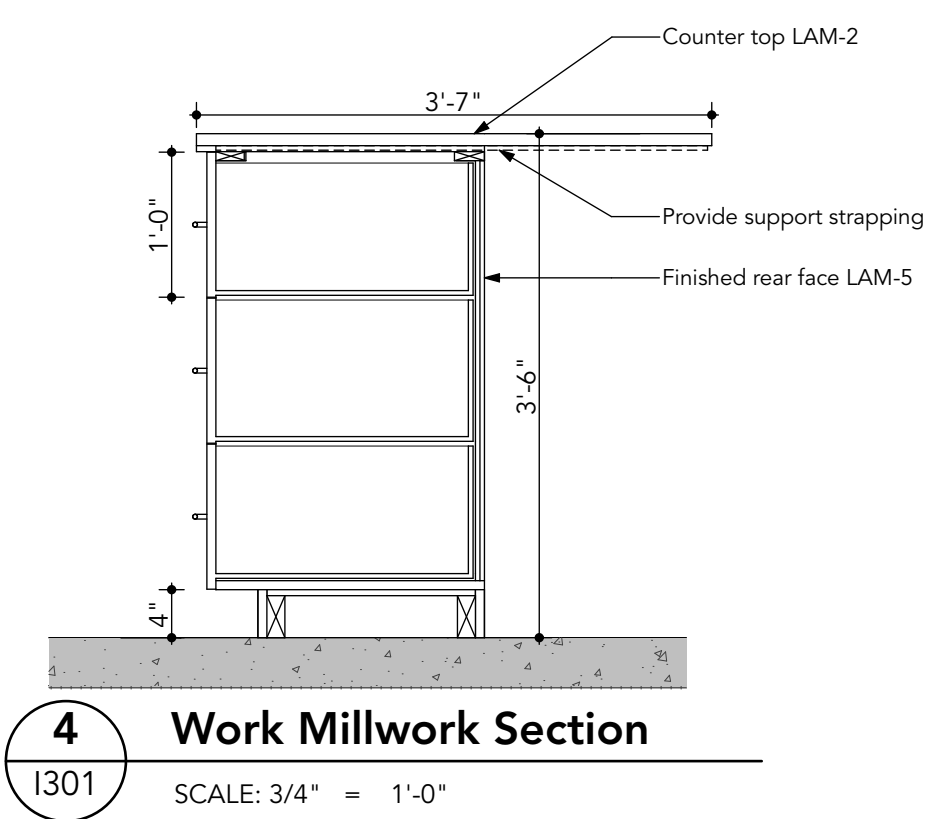


6 Corridor Looking South
1203 SCALE: 1/4" = 1'-0"

NOT FOR
REGULATORY
APPROVAL,
PERMITTING, OR
CONSTRUCTION

Bid Set 08/21/2025
Site Plan Review 07/31/2025
DD Set 07/03/2025
© 2025, Intersect studio, llc
Project Number: 23-046

Interior
Elevations- KDPS



NOT FOR
REGULATORY
APPROVAL,
PERMITTING, OR
CONSTRUCTION

Bid Set 08/21/2025
Site Plan Review 07/31/2025
DD Set 07/03/2025
© 2025, intersect studio, llc
Project Number: 23-046

Interior Details

TAG	ITEM	MANUFACTURER	STYLE	COLOR	SIZE	NOTES	SPEC	BOD
CARPET								
CPT-1	Carpet Tile Walk-Off	Shaw Contract	Path Tile 5T034	Sterling 34557	24" x 24" .281" thick	Monolithic Installation - See Plan for carpet direction Contact Ashley Hazel at 616-980-7391 or ashley.hazel@shawcontract.com	09 6813	BOD
CPT-2	Carpet Tile Walk-Off	Shaw Contract	Path Tile 5T034	Navy 34485	24" x 24" .281" thick	Monolithic Installation - See Plan for carpet direction Contact Ashley Hazel at 616-980-7391 or ashley.hazel@shawcontract.com	09 6813	BOD
CPT-3	Carpet Tile - Field CPED	Mohawk	Collection Shape Theory Corresponding Angle BT599 Kristin	977 Iron Index	24"x24" 0.297" thick	Installation pattern monolithic Contact Kristin Boos at 248-803-1754 or kristin.boos@mohawk.com	09 6813	
CPT-4	Carpet Tile - Field KOPS	Interface		103333 Linen	50cm x 50cm .218" thick	Installation Monolithic Contact Shelbe Ogburn at 616-370-6087 or shelbe.ogburn@interface.com	09 6813	
CPT-5	Carpet Tile	Shaw Contract	Zest Tile 5T487	Brio-Color 87485	24" x 24" tile .32" thick	Monolithic Installation - See Plan for carpet direction Contact Ashley Hazel at 616-980-7391 or ashley.hazel@shawcontract.com	09 6813	
CPT-6	Carpet Tile	Interface	Collection Granite Mountain Style Penola Mountain Rubber Base	Green Lichen 107302	19.69" x 19.69" .276" thick	Installation: Non-directional Contact Shelbe Ogburn at 616-370-6087 or shelbe.ogburn@interface.com	09 6813	
CPT-7	Carpet Tile	Patcraft	Raw Edge 10534	Moire 00950	18" x 36" plank .297" thick	Ashtar Installation - See plan for carpet direction Contact Ryan Morton at 616-260-6829 or ryan.morton@patcraft.com	09 6813	
CPT-8	Carpet Tile	ShawContract	Weathered Color Tile 5T426	Lake Still 88411	9" x 36" 0.318" thick	Stagger Installation - See plan for carpet direction Contact Ashley Hazel at 616-980-7391 or ashley.hazel@shawcontract.com	09 6813	
CPT-9	Carpet Tile	ShawContract	Gilded Tile 5T819	Lazurite Silver 18496	24" x 24" tile .292" thick	Installation Monolithic Contact Ashley Hazel at 616-980-7391 or ashley.hazel@shawcontract.com	09 6813	
CPT-10	Carpet Tile	ShawContract	Zest Tile 5T487	Brio 87518	24" x 24" tile .32" thick	Installation: Multi Directional Contact Ashley Hazel at 616-980-7391 or ashley.hazel@shawcontract.com	09 6813	
CPT-11	Carpet Tile- 2nd Floor Accent	Interface	Open Air 441	108320 Flannel	19.69" x 19.69" .232" thick	Installation: Contact Ashley Hazel at 616-370-6087 or shelbe.ogburn@interface.com	09 6813	
CPT-12	Carpet Tile	Mohawk	Wild Dyer- Curious Cluster GT353 Honesd Tile 5T236	585 Bottom of a Well Ivy 35375	24"x24" .393" thick 9"x36" .284" thick	Multi Directional installation Contact Kristin Boos at 248-803-1754 or kristin.boos@mohawk.com	09 6813	
CPT-13	Carpet Tile	Shaw Contract				Stagger Installation - See plan for carpet direction Contact Ashley Hazel at 616-980-7391 or ashley.hazel@shawcontract.com	09 6813	
CPT-14	Carpet Tile	Mohawk	Above and Below -Biotope GT357	555 Indigo Milk Cap	12" x 36" .365" thick	Stagger Installation - See plan for carpet direction Contact Kristin Boos at 248-803-1754 or kristin.boos@mohawk.com	09 6813	
CPT-15	Carpet Tile	Interface FLOR	Squared Away 21-1589	Midnight/Pearl	24" x 24" .315" Thick	Monolithic Installation - See Plan for carpet direction Contact Shelbe Ogburn at 616-370-6087 or shelbe.ogburn@interface.com	09 6813	
CPT-16	Carpet Tile - Field Upper Level	Interface	Open Air 418	108320 Flannel	19.69" x 19.69" .198" thick	Contact Shelbe Ogburn at 616-370-6087 or shelbe.ogburn@interface.com	09 6813	
RUBBER FLOORING								
RB-1	Rubber Flooring	Nora	Noramont Costello	5355 Palazzo	39.53" x 39.53" 3.9mm Thickness	Contact Chuck Timmerman with Interface at 616-481-1719 or chuck.timmerman@interface.com	09 6500	
RB-2	Rubber Flooring	Nora	Noramont Costello	5356 Domus	39.53" x 39.53" 3.9mm Thickness	Contact Chuck Timmerman with Interface at 616-481-1719 or chuck.timmerman@interface.com	09 6500	
RESILIENT FLOORING								
LVT-1	Luxury Vinyl Tile	Shaw Contract	Commingle 4350V	Concrete 50105	9" x 48" tile .197" thick	Stagger Installation. See Finish Plan for LVT install locations and direction Contact Ashley Hazel at 616-980-7391 or ashley.hazel@shawcontract.com	09 6519	
LVT-2	Luxury Vinyl Tile	Shaw Contract	Union 4369V	Sandy Dune 49242	9" x 48" tile .197" thick	Stagger Installation. See Finish Plan for LVT install locations and direction Contact Ashley Hazel at 616-980-7391 or ashley.hazel@shawcontract.com	09 6519	
LVT-3	Luxury Vinyl Tile	Interface	Level Set- Textured Woodgrains	Ash Walnut A04049	252x9mm 4.5mm	Stagger & Herringbone Installation. See Finish Plan for LVT install pattern locations and direction Contact Shelbe Ogburn at 616-370-6087 or shelbe.ogburn@interface.com	09 6519	
RST-1	Modular Linoleum Flooring	Forbo	Marmoleum Modular	T3048 Graphite	19.69" x 19.69" 1" thick	Contact Stephanie Gutowski with Forbo at 248-388-8805 or stephanie.gutowski@forbo.com	09 6516 13	BOD
RST-2	Sports Flooring	Johnsontite	Replay Commonion Street Flooring	Bluestone RA6	4'x5' 9.5 mm Thick	Contact Jennifer Conway with Tarkett at 248 639 8161	09 6566	BOD
STAIR TREADS								
ST-1	Homogenous Rubber Stair Treads	Nora	Noramont Arago Stairtreads	5178 Calm	Coord. Stair tread size with current tread and riser dimensions. 59mm Thick	Include 0122 Light Grey Smooth VI visually impaired strips on all treads. Contact Chuck Timmerman with Interface at 616-481-1719 or chuck.timmerman@interface.com	09 6519	
TILE								
T-1	Porcelain Floor Tile - Toilet Room	Platform Surfaces	Cove	Storm	12"x24"	Installation Method: Third offset. Grout: Joint 1/8" GR-1 Contact Jordan Griffs with Platform Surfaces at 616-648-4448 or jgriffs@platformsurfaces.com	09 3013	
T-2	Wall Tile	Platform Surfaces	Infinity	Sky Wave	12"x24"	Installation Method: Stacked Horizontal. Grout: Joint 1/8" GR-2 Contact Jordan Griffs with Platform Surfaces at 616-648-4448 or jgriffs@platformsurfaces.com	09 3013	
T-3	Ceramic Tile	Stonesource	Palma Craft	Cotto, Glossy	5" x 5" square tile 8.8mm Thickness	See Elevation 5/1201 & 6/1203 for installation pattern. Grout: 1/8" joint. GR-2 Use Schluter Jolly- Satin Anodized on exposed edges, size to coord. W/ tile thickness. Contact Iris Robinson at 312-909-0215 or ir@stonesource.com	09 3013	
T-4	Ceramic Tile	Stonesource	Palma Craft	Cotto, Glossy	2 1/2" x 5" tile 8.8mm Thickness	-	09 3013	
T-5	Ceramic Wall Tile	Stonesource	Palma Craft	Marine, Glossy	5"x8" 8.8mm Thickness	See Elevation 30/1202 for installation pattern. Grout: 1/8" joint. GR-4 Use Schluter Jolly- Satin Anodized on exposed edges, size to coord. W/ tile thickness. Contact Iris Robinson at 312-909-0215 or ir@stonesource.com	09 3013	
T-6	Ceramic Wall Tile	Stonesource	Palma Craft	Marine, Glossy	2 1/2" x 5" 8.8mm Thickness	-	09 3013	
T-7	Porcelain Wall Tile	Platform Surfaces	Kit Kats	Midnight, Glossy	4 1/2" x 8 1/2" 8.9mm Thickness	Stacked vertical installation pattern. Grout: 1/8" joint. GR-5 Use Schluter Jolly- Satin Anodized on exposed edges, size to coord. W/ tile thickness. Contact Jordan Griffs with Platform Surfaces at 616-648-4448 or jgriffs@platformsurfaces.com	09 3013	
T-8	Porcelain Wall Tile	Tilebar	Rework Leather	Gray Blue	3" x 12" 10mm Thickness	1/3 Offset. Grout: 1/8" joint. GR-6 Use Schluter Jolly- Dark Anthracite on exposed edges, size to coord. W/ tile thickness. Contact Morgan Kline at 616-730-3036 or mkline@tilebar.com	09 3013	
T-9	Porcelain Wall Tile	Platform Surfaces	Vener World- Quarry Ledgestone River	Quarry Ledgestone River Smoke	6"x24" 9mm Thickness	Horizontal 1/3 Offset Installation, see 9/1202 for install pattern. Grout: Joint 1/8" GR-7 Contact Jordan Griffs with Platform Surfaces at 616-648-4448 or jgriffs@platformsurfaces.com	09 3013	
T-10	Wall Tile	Platform Surfaces	Infinity	Sky	12"x24" - cut to size for wall base 9mm Thickness	Grout: Joint 1/8" GR-2 Contact Jordan Griffs with Platform Surfaces at 616-648-4448 or jgriffs@platformsurfaces.com	09 3013	

TAG	ITEM	MANUFACTURER	STYLE	COLOR	SIZE	NOTES	SPEC	BOD
GR-1	Grout	Laticrete	Permicolor Select	60 Dusty Grey				BOD
GR-2	Grout	Laticrete	Permicolor Select	93 Fossil				BOD
GR-3	Grout	Laticrete	Permicolor Select	45 Quarry				BOD
GR-4	Grout	Laticrete	Permicolor Select	53 Twilight Blue				BOD
GR-5	Grout	Laticrete	Permicolor Select	91 Slate Grey				BOD
GR-6	Grout	Laticrete	Permicolor Select	45 Raven				BOD
GR-7	Grout	Laticrete	Permicolor Select	87 Stormy Grey				BOD
WALL BASE								
WB-1	Rubber Base	Johnsontite	TSBT Baseworks Straight Toolless Rubber Base	Burnt Umber, 63	4" Tall	Use RB-1 unless otherwise noted. Contact Sheri Datema with Florstar at sdatema@florstar.com or 616-202-5540	09 6513	
WB-2	Rubber Base	Johnsontite	Shoe Moulding MW-83-D	Burnt Umber, 63	1.5" Tall		09 6513	
WB-3	Molded "Millwork" Rubber Base	Johnsontite	Ledge MW-55-X62	Silver Grey 55, WG	6" Tall	Use in Rooms 127,180,181,191 unless otherwise noted. Contact Sheri Datema with Florstar at sdatema@florstar.com or 616-202-5540	09 6513	
WB-4	Tile Cove Base	Platform Surfaces	Cove	Storm	6"x12" Cove Base	Grout spec & grout joint to match proposed room floor tile. Contact Jordan Griffs with Platform Surfaces at 616-648-4448 or jgriffs@platformsurfaces.com	09 6513	
WB-5	Rubber Base	Johnsontite	TSB Whb Toe / Cove Rubber Base	Silver Grey 55, WG	4" Tall	To be used in room 127, 119, 126, 123	09 6513	
PAINT								
PT-1	Field Paint	Sherwin Williams		Greek Villa SW 7551		Use on Gyp. Bd. Walls unless otherwise noted. See General notes for more info. Contact Karen McJannet with Sherwin Williams at 317-714-9510 or karen.mcljannet@sherwin.com	09 9123	BOD
PT-2	Mid Grey	Sherwin Williams		Revelstone SW7542		See General Notes for more info	09 9123	BOD
PT-3	Dark Grey	Sherwin Williams		Peppercorn SW 7574			09 9123	BOD
PT-4	Light Green	Sherwin Williams		Escape Gray SW 6485			09 9123	BOD
PT-5	Light Blue	Sherwin Williams		Meditative SW 6227			09 9123	BOD
PT-6	Mid Blue	Sherwin Williams		Smoky Blue SW7504			09 9123	BOD
PT-7	Bright Blue	Sherwin Williams		Lobelia SW6809			09 9123	BOD
PT-8	Terra Cotta	Sherwin Williams		Rajo Dust SW9006			09 9123	BOD
PT-9	Green	Sherwin Williams		Privilege Green SW6939			09 9123	BOD
PT-10	Mid Green	Sherwin Williams		Rosemary SW6197			09 9123	BOD
PT-11	Dark Blue	Sherwin Williams		Dark Night SW6527			09 9123	BOD
PT-12	White	Sherwin Williams		High Reflective White SW7757			09 9123	BOD
PT-13	Taupe	Sherwin Williams		Virtual Taupe SW7039		See Exterior Elevations for substrate info	09 9123	BOD
PT-14	Tan	Sherwin Williams		Tatami Tan SW6116		See Exterior Elevations for substrate info	09 9123	BOD
WOOD								
WD-1	Wood Slats		1"x4" Select Maple Flat stock	WS-1		See elevations for installation pattern & locations. Install slats with 3/4" gap between each	06 4023	BOD
WD-2	Wood Slats		2" x 8" Finish Grade Maple or Red Oak	WS-2		See elevations & RCP for dimensions & locations.	06 4023	BOD
WD-3	Wood Trim		1"x3" Select Maple flat stock	WS-3		Wood to detail lobby columns	06 4023	BOD
WD-4	Wood Coffered Ceiling	ASI Architectural	Beam System	PS Walnut Veneer, Clear Lacquer Finish	1" Width 6" Height	Contractor to provide sample of clear coat on proposed wood species for designer approval.	06 4023	BOD
WD-5	Wood Trim - to be painted		75"x1" Half Round	WS-5		Painted with attached wall color	06 4023	BOD
WD-6	Nat Used						06 4023	BOD
WD-7	Wood Ceiling System	Rulon	Linear Open System	White Oak Veneer with Felt Spacers	6" Module, 3/4" Reveal		06 4023	BOD
WD-8	Wood Trim - Cork Wall		Quarter Round Moulding	Painted with attached wall color	Coordinate w/ C-1 product thickness		06 4023	BOD
WD-9	Wood Trim - Lobby Bulkhead		1 1/2" x 3/4" Finish Grade Flat Moulding	WS-3		capture exposed edge	06 4023	BOD
WD-10	Wood Trim - Window Sills		2 1/2" x 1" Finish grade Flat Moulding	WS-X			06 4023	BOD
WOOD STAIN								
WS-1	Clear Coat	Minwax Polyrylic		Clear		Contractor to provide sample of clear coat on proposed wood species for designer approval.	06 4023	BOD
WS-2	Wood Stain	Minwax Wood Finish Penetrating Stain		To match Wilsonart Laminate Uptown Walnut 7929		To match Wilsonart Laminate Uptown Walnut 7929	06 4023	BOD
WS-3	Wood stain	Minwax Wood Finish Penetrating Stain		To match LAM-1		Contractor to provide three different stain options on proposed wood species for designer approval.	06 4023	BOD
WS-4	Wood stain	Minwax Wood Finish Penetrating Stain		To match LAM-3		Contractor to provide three different stain options on proposed wood species for designer approval.	06 4023	BOD
LAMINATE								
LAM-1	Laminate	Wilsonart	Premium Laminate	8239K-05 Continental Walnut			06 4023	BOD
LAM-2	Laminate - Countertops	Wilsonart	Premium Laminate	Magnolia 5022K-38 Textured Gloss			06 4023	BOD
LAM-3	Laminate	Wilsonart	Premium Laminate	7984K-12 Landmark Wood Softgrain			06 4023	BOD
LAM-4	Laminate - Kitchen Millwork	Wilsonart	Standard Laminate	Norwegian Ash 8241-38 Fine Velvet Finish		Contact Jon Rauch with Lumbermen's at 616-291-1430 or jonrauch@lumbermens-inc.com	06 4023	BOD
LAM-5	Laminate - Report Room Millwork	Wilsonart	Standard Laminate	Laminate to match existing dark wood grain casework in report room			06 4023	BOD
LAM-6	Laminate - Transaction Counter Wall	Wilsonart	Standard Laminate	Slate Grey Dgo-50 Matte Finish			06 4023	BOD
LAM-7	Laminate - Booth Casework	Wilsonart	Standard Laminate	Brittany Blue D321-60 Matte Finish			06 4023	BOD
LAM-8	Melamine		Melamine Board	White	3/4" thick, coord length and depth with all size		06 4023	BOD
WALL PANELS								
WP-1	Fiberglass Reinforced Plastic	PANOLAM	FRP	White, Embossed		Install up to 60" Contact Marybeth Watson at 678-868-1005 or marybeth_watson@panolam.com	10 2623	BOD
WP-2	Wall Protection	Inpro	Paladium Rigid Sheet Solid Color	0237 Slate	0.40" thick, 4x8" standard	Install up to 48" finish with solid color trim to match: top cap, vertical divider, inside & outside corner	06 4023	BOD
STS-1 / WP-4	Stainless Steel Wall Panel	Inpro	Stainless Steel Wall Protection		4"x10" (fabricated to 2x6 18 gauge standard, brushed)		09 7813	BOD
SOLID SURFACE								
SS-1	Quartz Countertop	Wilsonart	Quartz Select	Terlingua G602a		Straight Edge profile	12 3561	BOD
SS-2	Quartz Countertop	Wilsonart	Quartz Select	Urban Cloud G6018		Contact Jon Rauch with Lumbermen's at 616-291-1430 or jonrauch@lumbermens-inc.com	12 3561	BOD
CORK								
C-1	Cork Wall Panel w/ MDF Core	Stacked Wood	8100	Corcho Natural	12" x 48" 0.39" thick	Contact Andrea Angers at 248-302-1355 or andrea@bbboyd.com	06 4200	BOD

TAG	ITEM	MANUFACTURER	STYLE	COLOR	SIZE	NOTES	SPEC	BOD
WALLCOVERING								
WC-1	Vinyl Wallcovering	Momentum	Fracture SG3000	Diamond	20 oz/ly 52/54"W 12 5/8" V repeat	Contact Brandi Weiss at 313-720-2871 or bweiss@montex.com	09 7200	
WC-2	Vinyl Wallcovering	Momentum	Senza A200-327	Nettuno	20 oz/ly 52/54"W 24" X 12 1/2" H repeat		09 7200	
GRAPHIC WALLCOVERING								
GR-WC	Custom Wallcovering					To be coordinated in branding package. Contractor to prep wall for vinyl wallcovering (by others)	09 7200	
DOOR FINISH								
DF-1	Decorative Film	3M Di-NOC	Basic Woodgrain	WG-1196	48" w	See door schedule installed by 3M certified installer on existing doors.		
DF-2	Wood Door	VT Industries	Red Oak	Rivestone R118 - Wood Veneer to match LAM-1		See Door Schedule		BOD
DF								

NOT FOR
 REGULATORY
 APPROVAL,
 PERMITTING, OR
 CONSTRUCTION

Bid Set 08/21/2025
 Site Plan Review 07/31/2025
 DD Set 07/03/2025
 © 2025, Intersect studio, llc
 Project Number: 23-046

Room Finish
 Schedule

ROOM FINISH SCHEDULE										
ROOM #	ROOM NAME	FLOOR MATERIAL	BASE	WALL NORTH	EAST	SOUTH	WEST	CEILING MATERIAL	HEIGHT	NOTES
100	Director	CPT-7	WB-1	PT-5	PT-6, PT-5	PT-5	PT-5	ACT-2	9'-0" A.F.F.	
101	Focus	CPT-8	WB-1	PT-1	PT-1	PT-1	PT-5	ACT-2	9'-0" A.F.F.	
102	RR	T-1	Exist	PT-1	PT-1	PT-1	PT-1	Exist		
103	Economic Dev.	CPT-3	WB-1	PT-1	PT-1	PT-1	PT-1, PT-5**	ACT-1	9'-0", 10'-0" A.F.F.	
104	IT	RST-1	WB-1	PT-1	PT-1	PT-1	PT-1	Open to Struc.		
105	Connect	CPT-9	WB-1	PT-5	PT-1	PT-1	PT-1	Exist		
106	Large Connect	CPT-10	WB-1	PT-1	PT-1	PT-7	PT-6	ACT-3	9'-0" A.F.F.	
107	Huddle	CPT-8	WB-1	PT-5	PT-1	PT-1	PT-1	ACT-2	9'-0" A.F.F.	
108	ED Manager	CPT-7	WB-1	PT-1	PT-1	PT-1	PT-2	ACT-2	9'-0" A.F.F.	
109	Storage	CPT-8	WB-1	PT-1	PT-1	PT-1	PT-1	ACT-4	9'-0" A.F.F.	
110	Focus	CPT-3	WB-1	PT-9	PT-1	PT-1	PT-1	ACT-2	9'-0" A.F.F.	
111	Corridor	CPT-3	WB-1	PT-1	PT-1	PT-1	PT-1	ACT-1	10'-0" A.F.F.	
112	Fin Ops Manager	CPT-7	WB-1	PT-2	PT-1	PT-1	PT-1	ACT-2	9'-0" A.F.F.	
113	CD Manager	CPT-7	WB-1	PT-2	PT-1	PT-1	PT-1	Exist		
114	Comm Dev	CPT-3	WB-1	PT-1	N/A	PT-1	PT-1	ACT-1	10'-0" A.F.F.	
115	Copy/Print	CPT-3	WB-1	N/A	PT-5**	N/A	N/A	ACT-1	10'-0" A.F.F.	
116	Hoteling	CPT-3	WB-1	PT-1	N/A	PT-1	PT-1	ACT-1	10'-0" A.F.F.	
117	Huddle	CPT-8	WB-1	PT-1	PT-1	PT-9	PT-9	ACT-1	9'-0" A.F.F.	
118	Corridor	CPT-3	WB-1	N/A	PT-1	PT-6	PT-1	ACT-1	9'-0" A.F.F.	
119	Corridor	LVT-1	WB-5	PT-6	PT-9**	PT-9, PT-5**	PT-1	ACT-4	9'-0" A.F.F.	
120	Pln Stor	RST-1	WB-1	PT-1	PT-1	PT-1	PT-1	Open to Struc.		
121	Elec.	Exist	Exist	Exist	Exist	Exist	Exist	Open to Struc.		
122	Womens	T-1	WB-4	PT-1	PT-1	PT-1	PT-1	Exist		
123	Vending	LVT-1	WB-5	PT-1	PT-1	PT-1	PT-5	ACT-1	9'-0" A.F.F.	
124	Mens	T-1	WB-4	PT-1	PT-1	PT-1	PT-1	Exist		
125	Cl.	T-1	Exist					Open to Struc.		
126	Break	LVT-1	WB-5	PT-5	T-3, T-4, PT-5	PT-9**	T-3, T-4, PT-5	ACT-6	9'-0" A.F.F.	
127	Town Square	LVT-1, LVT-2*	WB-5	PT-6	GR-WC	PT-9, WD-1**	GR-WC, PT-9	ACT-1, GYP, AC-1, AC-2	10'-0" A.F.F. & 12'-0" A.F.F.	
128	Focus	CPT-8	WB-1	PT-9	PT-1	PT-9	PT-9	ACT-2	9'-0" A.F.F.	
129	Planning	CPT-3	WB-1	PT-1	PT-1, PT-2**	PT-6**	N/A	ACT-1	10'-0" A.F.F.	
130	Cl.	T-1	Exist					Open to Struc.		
131	Pln Office	CPT-7	WB-1	PT-1	PT-1	PT-2	PT-1	ACT-2	9'-0" A.F.F.	
132	Pln Office	CPT-7	WB-1	PT-1	PT-1	PT-2	PT-1	ACT-2	9'-0" A.F.F.	
133	Pln Office	CPT-7	WB-1	PT-1	PT-1	PT-2	PT-1	ACT-2	9'-0" A.F.F.	
134	Pln Office	CPT-7	WB-1	PT-1	PT-1	PT-2	PT-1	ACT-2	9'-0" A.F.F.	
135	Office	CPT-3	WB-1	PT-2	PT-1	PT-1	PT-1	ACT-2	8'-0" A.F.F.	
136	Office	CPT-3	WB-1	PT-2	PT-1	PT-1	PT-1	ACT-2	8'-0" A.F.F.	
137	Connect	CPT-6	WB-1	PT-9, Glazing	PT-9, Glazing	WC-2	PT-9**	ACT-8	10'-0" A.F.F.	
138	Central Park	CPT-6*	WB-1	PT-8, PT-9, PT-7**	PT-5	PT-7	WD-1, Glazing See Elev.**	GYP, GR-WC, PT-7***	10'-0" A.F.F.	
139	Main Street	CPT-3*	WB-1	N/A	PT-5, PT-6**	WD-1**	PT-7	GYP, PT-12, ACT-1	10'-0" A.F.F. & 11'-0" A.F.F.	
140	Finance/ Admin	CPT-7	WB-1	PT-5	PT-1	PT-1	PT-1	ACT-2	9'-0" A.F.F.	
141	Focus	CPT-8	WB-1	PT-5	PT-1	PT-1	PT-1	ACT-2	9'-0" A.F.F.	
142	Focus	CPT-8	WB-1	PT-5	PT-1	PT-1	PT-1	ACT-2	9'-0" A.F.F.	
143	Jan	RST-1	WB-1	PT-1, FRP-1	PT-1, FRP-1	PT-1, FRP-1	PT-1, FRP-1	Open to Struc.		FRP-1 to 8' aff, paint above
143-B	Elec.	Exist	Exist	Exist	Exist	Exist	Exist	Open to Struc.		
144	Building Trades	CPT-3	WB-1	PT-1	PT-1	N/A	PT-9**	ACT-1	10'-0" A.F.F.	
145	Help Desk	CPT-3	WB-1	PT-1	PT-1	PT-1	PT-1	ACT-1	9'-0" A.F.F.	
146	Clerk/Cashier	CPT-3	WB-1	PT-1	PT-1	GR-WC**	PT-1	ACT-1	9'-0" A.F.F.	
147	Storage	CPT-3	WB-1	PT-1	PT-1	PT-1	PT-1	ACT-4	9'-0" A.F.F.	
148	Service Court	CPT-3	WB-1	PT-6**	N/A	PT-5**	N/A	ACT-1	9'-0" A.F.F.	
149	Bldg Trades Office	CPT-7	WB-1	PT-2	PT-1	PT-1	PT-1	ACT-2	9'-0" A.F.F.	
150	Code Comp. Office	CPT-7	WB-1	PT-2	PT-1	PT-1	PT-1	ACT-2	9'-0" A.F.F.	
151	Fire Marshall	CPT-4	WB-1	PT-1	PT-1	PT-1	PT-2	ACT-2	9'-0" A.F.F.	
152	Corridor	CPT-3	WB-1	PT-1	PT-1	PT-1	PT-1	ACT-1	9'-0" A.F.F.	
153	Service Desk	CPT-3	WB-1	PT-1	PT-5**	PT-1	PT-1	ACT-1	10'-0" A.F.F.	
154	I.T. Storage	CPT-3	WB-1	PT-1	PT-1	PT-1	PT-1	ACT-4	9'-0" A.F.F.	
155										
156	I.T. Office	CPT-3	WB-1	PT-1	PT-5**	PT-1	PT-1	ACT-1	9'-0" A.F.F.	
157	I.T. Office	CPT-7	WB-1	PT-1	PT-1	PT-1	PT-2	ACT-2	9'-0" A.F.F.	
158	Elec.	Exist	Exist	Exist	Exist	Exist	Exist	Open to Struc.		
159	Storage	RST-1	WB-2	PT-1	PT-1	PT-1	PT-1	Exist	9'-0" A.F.F.	
160	IT	RS-1	WB-2	PT-1	PT-1	PT-1	PT-1	Open to Struc.		
161	Corridor	RST-1	WB-2	WP-3, PT-1	WP-3, PT-1	WP-3, PT-1	WP-3, PT-1	ACT-4	9'-0" A.F.F.	
162	Building Trades	CPT-3	WB-1	PT-1	PT-1	PT-1	PT-5	ACT-1	10'-0" A.F.F.	
163	Code Compliance	CPT-3	WB-1	PT-1	PT-5**	PT-1	PT-1	ACT-1	9'-0" A.F.F.	
164	Hoteling	CPT-3	WB-1	PT-1	PT-1	PT-1	PT-5	ACT-1	10'-0" A.F.F.	
165	Fire Prev.	CPT-4	WB-1	PT-1	PT-1	PT-1	PT-1	ACT-1	9'-0" A.F.F.	
166	FM Storage	CPT-4	WB-1	PT-1	PT-1	PT-1	PT-1	ACT-4	9'-0" A.F.F.	
167	Fire Marshall	CPT-4	WB-1	PT-1	PT-2	PT-1	PT-1	ACT-2	9'-0" A.F.F.	
168	KDPS Waiting Area	CPT-5	WB-1	PT-1	PT-6, GR-WC**	PT-6, GR-WC**	PT-1	ACT-1	10'-0" A.F.F.	
169	Connect	CPT-5	WB-1	PT-1	PT-1	PT-5	PT-5	ACT-2	9'-0" A.F.F.	
170	Vestibule	CPT-1	T-10	Glazing	Glazing	Glazing	Glazing	ACT-1	10'-8" A.F.F.	
171	Welcome	RB-1, RB-2	T-10	PT-1	PT-1	N/A	PT-1	Open to Above, ACT-1	10'-8" A.F.F.	
172	Waiting	RB-1, CPT-5*	WB-3	PT-1	PT-6**	PT-3, LAM-1**	N/A	GYP, PT-12, PT-4, WD-4	12'-0" A.F.F. & 9'-6" A.F.F.	
173	Men's	T-1	WB-4	PT-1	PT-1	PT-1	PT-1	Exist		
174	Women's	T-1	WB-4	PT-1	PT-1	PT-1	PT-1	Exist		
175	C.I.	RB-1	WB-1	PT-1	PT-1	PT-1	PT-1	Exist		
176	Records Work	CPT-4	WB-1	PT-1	PT-6	PT-1, PT-6**	PT-1	ACT-1	9'-0" A.F.F.	
177	Records	Exist	Exist	Exist	Exist	Exist	Exist	Exist		
178	Service Desks	CPT-4	WB-1	PT-1	PT-4	PT-1	PT-1	ACT-1	9'-0" A.F.F.	
179	F.P.	CPT-4	WB-1	PT-1	PT-1	PT-1	PT-1	ACT-1	9'-0" A.F.F.	
180	Lobby	RB-1, RB-2, CPT-5*	WB-2, WB-3, T-10**	N/A	PT-6, PT-3, LAM-1**	PT-3, PT-6 LAM-1	WC-1, GR-WC	GYP, PT-12, PT-4, WD-4	12'-0" A.F.F. & 9'-6" A.F.F.	
181	Corridor	RB-1	WB-3	PT-4**	PT-1	GR-WC**	PT-1	ACT-1	10'-0" A.F.F.	
182	Connect	CPT-9	WB-1	PT-1	PT-1	GR-WC, PT-7**	PT-7	GYP, PT-12, ACT-1, WD-7	9'-0" A.F.F. & 10'-0" A.F.F.	
183	Court Officer	CPT-4	WB-1	PT-1	PT-1	PT-2	PT-2	ACT-2	9'-0" A.F.F.	
184	Fleet Manager	CPT-4	WB-1	PT-1	PT-1	PT-2	PT-1	ACT-2	9'-0" A.F.F.	
185	Corridor	CPT-4	WB-1	PT-1	PT-2**	PT-2**, PT-1	PT-1	ACT-1	9'-0" A.F.F.	
186	Focus	CPT-4	WB-1	PT-4	PT-1	PT-1	PT-1	ACT-2	8'-0" A.F.F.	
187	Focus	CPT-4	WB-1	PT-4	PT-1	PT-1	PT-1	ACT-2	8'-0" A.F.F.	
188	Recharge	CPT-4	WB-1	PT-6	PT-6**, PT-1	PT-1	PT-1	ACT-2	8'-0" A.F.F.	
189	Recharge	CPT-4	WB-1	PT-1	PT-1	PT-1	PT-11	ACT-2	8'-0" A.F.F.	
190	Linem	CPT-4	WB-1	PT-1	PT-1	PT-4	PT-1	ACT-1	8'-0" A.F.F.	
191	Lobby	RB-1	WB-3	PT-11	PT-10	PT-9	PT-8	GYP, GR-WC, ACT-1	10'-0" A.F.F. & 9'-0" A.F.F.	
192	Connect	CPT-12	WB-1	PT-1	PT-1	PT-6	PT-1	ACT-2	9'-0" A.F.F.	
193	Vestibule	CPT-2	WB-3	PT-1	GR-WC	PT-1	PT-1	ACT-1	9'-4" A.F.F.	
194	Focus	CPT-12	WB-1	PT-10	PT-10	PT-1	PT-1	ACT-2	9'-0" A.F.F.	
195	Work Cafe	LVT-3, CPT-15*	WB-1	PT-11, T-9**, PT-1	PT-10, PT-4 GR-WC, T-7**	PT-1	PT-11, PT-10	GYP, PT-1, PT-3***, ACT-7, WD-2	9'-6" A.F.F. 9'-4" A.F.F. Open to Struc	
196	Corridor	CPT-4	WB-1	PT-1	PT-1	PT-11, GR-WC**	PT-1	ACT-1, WD-2, PT-3, GYP	9'-0" A.F.F. 8'-4" A.F.F. 8'-6" A.F.F.	
197	Kitchen	LVT-3	WB-1	PT-10**	PT-4, T-8, STS-1**	PT-4	PT-4, T-8	ACT-6	9'-6" A.F.F.	

ROOM FINISH SCHEDULE										
ROOM #	ROOM NAME	FLOOR MATERIAL	BASE	WALL NORTH	EAST	SOUTH	WEST	CEILING MATERIAL	HEIGHT	NOTES
198-213										
214	Corridor	CPT-4	WB-1	PT-1	PT-11, PT-1	PT-11, PT-1	PT-1	ACT-1	9'-0" A.F.F.	
215	Admin	CPT-4	WB-1	PT-2**	PT-1	PT-1	PT-1	ACT-2	9'-0" A.F.F.	
216	Shift Command	CPT-4	WB-1	PT-1	PT-1	PT-2**	PT-2	ACT-1	9'-0" A.F.F.	
217	Equip.	Exist	Exist	Exist	Exist	Exist	Exist	Exist		
218	Meet	CPT-4	WB-1	PT-1	PT-6**	PT-1	PT-1	ACT-2	9'-0" A.F.F.	
219	Copy	CPT-4	WB-1	PT-1	PT-1	PT-11**	PT-1	ACT-1	9'-0" A.F.F.	
220	Corridor	CPT-4	WB-1	Exist	Exist	Exist	Exist	Exist		
221	Corridor	CPT-4	WB-1	Exist	Exist	Exist	Exist	Exist		
222-250										
251	Women's	T-1	WB-4	PT-1	PT-1	PT-1	PT-1	Exist		
252	Clos.	T-1	Exist	PT-1	PT-1	PT-1				

STRUCTURAL ABBREVIATION INDEX

ABBREV.	ITEM
A/E	Architect/Engineer
AB	Anchor Bolt/Column Anchor Rod
ACIP	Augered Cast In Place
AESS	Architecturally Exposed Structural Steel
AFF	Above Finished Floor
ALT	Alternate
AP	Anchor Plate
ARCH	Architectural
BB	Bond Beam
BC	Bottom Chord
BCX	Bottom Chord Extension
BFF	Below Finished Floor
BL	Brick Ledge
BM	Beam
BO	Bottom of
BOS	Bottom of Steel
BP	Bearing Plate
BRG	Bearing
BT	Bent
C/C	Center-to-Center
CANT	Canthiever
CBP	Column Base Plate
CFMF	Cold Formed Metal Framing
CFMT	Cold Formed Metal Truss
CJ	Construction Joint
CJ	Contraction Joint
CJ	Control Joint
CJP	Complete Joint Penetration Weld
CL	Centerline
CLR	Clear
CMU	Concrete Masonry Unit
COL	Column
CONC	Concrete
CONN	Connection, Connect
CONT	Continuous
COORD	Coordinate
DA	Deck Angle
DB	Deck Bar
DBE	Deck Bearing Elevation
DIA, Ø	Diameter
DP	Deck Plate
DWG	Drawing(s)
EA	Each
EF	Each Face
EL	Elevation
EQ	Equal
ES	Each Side
EW	Each Way
EX	Existing
EXP	Expansion
EXT	Exterior
FD	Floor Drain
FDN	Foundation
FF	Finished Floor
FFE	Finished Floor Elevation
FP	Foundation Pier
FS	Far Side
FTG, F	Footing
FV	Field Verify
GA	Gauge
GALV	Galvanized
GB	Grade Beam
GS	Grout Solid
GT	Girder Truss
HD	Hold Down Anchor
HORZ	Horizontal
HP	High Point
HS	Headed Stud
HT	Height
ID	Inside Diameter
IF	Inside Face

STRUCTURAL ABBREVIATION INDEX

ABBREV.	ITEM
INT	Interior
JB	Joist Bearing Elevation
L	Lintel
L	Lintel
LAT	Lateral
LD	Load
LF	Linear Foot
LG	Long
LLH	Long Leg Horizontal
LLV	Long Leg Vertical
LOCN	Location
LP	Low Point
LT	Light
LW	Long Way
LWB	Laminated Wood Beam
MAX	Maximum
MCJ	Masonry Control Joint
MECH	Mechanical
MIN	Minimum
NS	Near Side
NTS	Not To Scale
O/O	Out-to-Out
O	On-Center
OD	Outside Diameter
OF	Outside Face
OFD	Overflow Drain
OH	Opposite Hand
P	Pier
PAF	Power Actuated Fastener
PC	Precast
PEMB	Pre-Engineered Metal Building
PERP	Perpendicular
PL	Plate
PT	Pressure Treated
R, RAD	Radius
RD	Rod Drain
RE:	Reference, Refer to
REINF	Reinforce
REM	Remainder
REQD	Required
RMW	Reinforced Masonry Wall
RTU	Roof Top Unit
RXN	Reaction
SC	Slip Critical
SF	Step Footing
SIM	Similar
SIP	Structural Insulated Panel
SOG	Slab On Grade
SPCS	Spaces
SS	Stainless Steel
SST	Simpson Strong Tie
STL	Steel
SW	Short Way
T&B	Top and Bottom
TC	Top Chord
TOX	Top Chord Extension
TO	Top of
TOB	Top of Beam
TOF	Top of Footing
TOL	Top of Ledger
TOM	Top of Masonry
TOS	Top of Steel
TOW	Top of Wall
TYP	Typical
UNO	Unless Noted Otherwise
VERT	Vertical
w/	With
w/o	Without
WF	Wall Footing
WP	Working Point
WWF	Welded Wire Fabric

GENERAL FOUNDATION AND CONCRETE NOTES

- The contractor shall implement all requirements and recommendations stated in the geotechnical engineer's report by SME, entitled "City of Kalamazoo Crosstown Facility", dated May 23, 2025. SME Project number 098378.00
- It is strongly recommended that the geotechnical engineer of record that produces the report be retained to provide the soils testing and inspections during construction.
- Fill material shall be thoroughly compacted prior to placement of concrete. Fill under all slabs on grade shall be as recommended in the geotechnical report. If there is no geotechnical report, a minimum of 8" of well draining granular material shall be placed under all slabs on grade (UNO elsewhere in the construction documents).
- Unless otherwise noted, a 15 mil, ASTM E 1745 Class A vapor barrier, with a permeability rate of 0.01 perms or lower, shall be placed under all slabs on grade after under floor work and compaction is complete. Seal all laps and penetrations. Turn up vapor barrier against wall at all slab edges.
- All building slabs are structural slabs and shall not have control/construction joints.
- Provide diagonal reinforcing (across each corner) of openings in foundation walls and slabs as follows: (1)-#4 x 44" for each 4' of concrete thickness.
- Coordinate finish of all foundation work, including slabs on grade, with architectural and flooring supplier's requirements.
- Lap all reinforcing as indicated in "Reinforcement Development and Lap Splice Lengths" detail. Provide corner bars for all horizontal reinforcing. Provide dowels from footing equal in size and number to vertical wall or pier reinforcing (UNO).
- Cover for reinforcing shall be in accordance with ACI-318.
- All exposed edges of concrete piers, beams, and walls shall be chamfered 3/4" x 45 degrees. UNO
- Provide beam pockets in foundation walls where needed. Fill pockets with concrete after beams are set.
- Grade beams and walls that retain earth on both sides shall be backfilled on both sides simultaneously.
- Do not backfill earth retaining walls until concrete has reached 75% of its required 28 day strength, and all bracing elements are in place (lower and upper floors).
- Coordinate placement of column anchor rods with foundation reinforcing. All column anchor rods shall be installed using templates and setting drawings. No tilted or misplaced bolts will be accepted. Notify Architect/Engineer for approval of any corrective action. Tolerances for the installation of the anchor bolts shall be in accordance with AISC "Code of Standard Practice" guidelines.
- Welded wire fabric shall conform to ASTM A185. Wire fabric reinforcement must lap one full mesh plus 2" at side and end laps, but not less than 6", and shall be wire tied together.
- Anchors for embedded plates shall be as shown on the drawings. Headed studs shall conform to ASTM A108 and AWS D1.1 Grade B. Reinforcing bars to be welded to plates shall be ASTM A615 Grade 40 or ASTM A706 Grade 60.
- Refer to "General Structural Notes" for information regarding special inspections and installation of post installed anchors.
- Foundation walls and slabs on grade are designed for a dry condition. Buildup of hydrostatic water pressure on walls is not permitted, and drainage shall be provided per the design requirements of non-structural design trades to prevent this condition from occurring.

GENERAL POST INSTALLED ANCHOR NOTES

- Post installed anchors shall only be used where specified on the construction documents. The contractor shall obtain approval from the Architect prior to installing post installed anchors in place of missing or misplaced cast-in-place anchors.
- Unless otherwise noted in the drawings all post installed anchors are based on Hilti Corporation product information.
- If the contractor wants to submit an alternate anchor they must provide sealed calculations at least 2 weeks prior to product use. These calculations must show that the strength of the substituted anchor meets or exceeds the strength of the specified anchor at each application in the project where a substituted anchor is proposed, with consideration for combined stress and any applicable design factors.
- Within contract documents adhesive anchors may be generically referred to as epoxy anchors, where this occurs substitute the word epoxy with adhesive.
- Adhesive anchors shall be installed in concrete having a minimum age of 21 days at time of anchor installation.
- Mechanical anchors shall be installed in concrete having a minimum age of 7 days, and concrete having met minimum concrete compressive strength (f'c).
- Anchorage to concrete shall be done by either expansion anchors or adhesive anchors.
- Anchorage to solid masonry shall be done by either adhesive anchors or screw anchors see details for specific use.
- Anchorage to hollow or multi-wythe masonry shall be done with screen anchors.
- Provide ICC approved adhesive anchors based on the following:
 - Concrete Anchors -
 - Automatic hole cleaning Hilti HIT-RE 500-V3 with HAS threaded rod or Hilti HIT HY 200 Safe Set with HY200 HAS threaded rod
 - No hole cleaning - Hilti HIT HY 200 Safe Set with HIT-Z or HIT-Z-R threaded rods.
 - Masonry anchor - Hilti HIT HY 270 with HAS-E rods
- Provide ICC approved mechanical anchors based on the following:
 - Torque Control (TC) anchor - Hilti Kwik bolt T22
 - Sleeve anchor - Hilti HLC Sleeve anchor
 - Screw anchor - Hilti Kwik HUS-EZ
- See specifications for specific product information and installation instructions, and drawings for application use.
- All installations shall be done by an individual certified by the manufacturer. Certifications shall be submitted to the special inspector prior to commencement of work.
- All anchors shall be inspected as described in specifications.
- Anchor capacity is dependant on anchor spacing and edge distances. Install bolts as detailed.
- If anchors cannot be installed as detailed notify Architect for alternate connection detail.
- Existing reinforcing bars in the concrete may conflict with specific anchor locations. Unless noted otherwise those bars are not to be cut. The contractor shall review the drawings and undertake a method to locate such bars.

CONCRETE MASONRY NOTES

- Concrete masonry units shall conform to ASTM C90, below grade units shall be medium or normal weight.
- Mortar shall conform to ASTM C270, and shall be made with Type I portland cement/lime or mortar cement. Mortar shall be Type S.
- Grout shall conform to ASTM C476.
- Reinforcing bars shall conform to ASTM A615, Grade 60, unless noted.
- Where existing masonry is removed and replaced reuse or match existing anchorage of masonry back to existing concrete. If no anchorage provided provide new anchor at each head joint for vertical connection, and a new anchor at 16" oc at horizontal connections.
- Provide layout shop drawings indicating lap splices, rebar spacing, bond beams, grout lifts, etc.
- Horizontal joint reinforcing (continuous wire reinforcing) shall be hot-dipped galvanized ladder type fabricated units with a single pair of 9 gage side rods and 9 gage cross rods at 16" oc fabricated from cold drawn steel wire complying with ASTM A82.
- Horizontal joint reinforcing shall be spaced at 16" oc in all masonry walls and shall be lapped 8", unless noted otherwise on the drawings.
- No chases, risers, conduits or toolings of masonry shall occur in masonry walls within 18" of centerline of beam bearing.
- When a foundation dowel does not line up with a vertical block core it shall not be sloped more than 1 horizontal in 6 vertical. Dowels may be grouted into a cell adjacent to the vertical wall reinforcing.
- Vertical bars shall be secured in place before grouting starts.
- Vertical bars shall be held in position at top and bottom of grout lifts, and at intervals not exceeding 200 diameters of the reinforcing bar.
- Vertical cells that will be grouted shall have a vertical alignment to maintain a continuous unobstructed cell area not less than 3" x 4".
- If high lift grouting is selected, cleanouts shall be provided at the base of each reinforced cell and at intervals as prescribed by ACI 530.1 (Section 3.2F).
- Consolidate grout lifts greater than 12" by mechanical means and reconsolidate by mechanical means after initial water loss and settlement. Lifts less than 12" may be consolidated by puddling or by mechanical means.
- All bolts, anchors, etc. inserted into the walls shall be grouted solidly into position.
- Joist and beam bearing plates shall be centered on the member that they support, within a tolerance of 1" on either side of the member centerline.
- Provide "Dur-O-Stop" grout screens (or equal) to terminate grout pours over open cells below, such as at bond beams.
- Coordinate bond beam locations with Architectural & Structural drawings.
- The masonry has been engineered, and shall be inspected in accordance with chapter 1 of TMS 402/ACI 530/ASCE 5 (Building Code Requirements for Masonry Structures). A minimum Level B Quality Assurance program is required (Level C for essential facilities). Periodic inspection shall be performed daily with a minimum of one inspection for every 1,500 square feet or portion thereof.
- Masonry has been designed and shall be built in conformance to TMS 402/ACI 530/ASCE 5 (Building Code Requirements for Masonry Structures) and TMS 602/ACI 530.1/ASCE 6 (Specifications for Masonry Structures).
- Contractor shall design and provide all temporary bracing required for strength and stability of the masonry throughout construction. At a minimum, comply with OSHA and local requirements for temporary bracing of walls.

CONCRETE MASONRY SPEC NOTES

- Provide vertical control joints in all CMU walls at a maximum spacing of 24' or two times the wall height, whichever is less. Coordinate joint locations with the bearing plate layout such that no joint is located within 16" from the centerline of a bearing plate. Joint reinforcing shall be stopped either side of vertical joints.
- Provide solid masonry or fill cores of block under all beam and lintel bearing points down to concrete wall or footing below.
- All reinforced cells shall be grouted solid.
- Spliced reinforcing shall be lapped 48 times the bar diameter, in inches.
- Vertical reinforcing bars shall have a minimum clearance of 3/4 of an inch from the masonry and not less than one bar diameter between bars.
- Grouting shall be stopped 1.5 inches below the top of a course so as to form a key at the pour.
- Bond beams are intended to be open-cell with "Dur-O-Stop" or equivalent grout stop below. Vertical reinforcing shall extend through or into bond beam. All bond beams shall be filled with grout. Refer to Architectural & Structural drawings for locations.

GENERAL STRUCTURAL NOTES

- All work shall be performed in accordance with the contract documents. In case of a conflict within the contract documents, the more stringent condition shall govern, unless directed otherwise by the engineer of record. Prior to implementation, any discrepancies shall be reported to the architect for clarification.
- In the event that certain details of construction are not indicated or noted in the drawings, details for similar conditions that are indicated or noted shall be utilized, subject to the structural engineer's approval.
- Openings and penetrations through structural elements, and items embedded in structural elements that are not indicated in the structural drawings shall be reviewed by the structural engineer prior to fabrication, erection and/or construction.
- Materials or equipment shall not be placed on unfinished floors or roofs in excess of 20 psf nor on finished floors in excess of the design live loads which are indicated in the structural drawings. Impact loading shall be avoided.
- The structure has been designed for the in-service loads only. The methods, procedures and sequences of construction are the responsibility of the contractor. Contractor shall take all necessary precautions to maintain and ensure the integrity of the structure at all stages of construction. Contractor shall immediately notify the structural engineer of any condition which, in his opinion, might endanger the stability of the structure or cause distress in the structure.
- All existing conditions and all related dimensions indicated in the contract documents shall be field verified prior to fabrication, erection and/or construction. Any condition that differs from that indicated in the contract documents shall be submitted to the architect for review prior to fabrication, erection and/or construction.
- The structure has been designed to meet or exceed serviceability requirements of section 1604.3 of the Michigan Building Code. All non-structural components & their connections that are anchored to the structure shall be designed to allow for the movement of the structure caused by wind, snow, live, thermal, shrinkage/creep and earthquake loads. Non-structural components include items such as non-load bearing walls, MEP components, bulkheads, etc.
- Provide special inspection in accordance with chapter 17 of the Michigan Building Code and with project specifications.
- Unless noted otherwise, all loads specified in these documents are nominal loads and are to be entered into the appropriate strength or allowable stress design load combinations with appropriate factors, as defined by ASCE 7, by the building component engineer in the design of their product. Gravity load shear beam reactions on plan for steel framing represent the combined service load effect from allowable stress design load combinations.
- Post installed anchors shall be the specific product indicated. Where product substitutions are desired, they shall be submitted to engineer for review & approval a minimum of 2 weeks prior to planned installation. Adhesive anchors shall be installed using products that are approved by the supplier for all temperature considerations. Installation shall be in accordance with suppliers published installation instructions.
- Copies or reproductions of architectural or structural drawings and details will not be accepted as shop drawings. Submittals received as such will not be reviewed and will be rejected.

LIGHT GAUGE METAL FRAMED WALL FRAMING NOTES

- It is the contractor's responsibility to design and detail all light gauge metal framing (studs, rafters, joists, etc) and their connections in accordance with the current local building code and AISI's Standards and Specifications. Provide shop drawings that indicate all member sizes and connection requirements including fasteners and clips. Shop drawings shall be sealed by a registered engineer in the state of Michigan for Architect's review.
- Light gauge metal stud sizes shown on plans & details are based on metal stud industry standards.
- Where stud depth, width, or thickness is indicated on drawings it shall be considered a minimum requirement.
- Provide minimum 43 mils studs where stud framing acts as backup for masonry veneer.
- Where metal studs provide backup for metal panel or other specialty finish material, the construction manager and stud supplier shall verify/coordinate minimum stud gauge thickness requirements with the supplier of the wall finish material. The metal panel/finish supplier may have minimum thickness requirements that must be met with stud backup.
- At openings in framed walls, all headers, sills, jamb studs, and related connections shall be designed to transfer wind and gravity loads to the supporting primary structure.
- Studs shall be securely attached to track components at the top and bottom of the wall assembly. Stud ends shall be seated tightly in all load-bearing walls.
- Fasteners along edges in shear panels shall be placed not less than 3/8 inch in from panel edge.
- Plywood/OSB sheathing shall be fastened to studs with No. 8 flat head screws with a minimum head diameter of 0.293 inches.
- Metal framing shall be fastened together with minimum #8 w/fer head self drilling screws.
- Unless noted otherwise, install 1/2" diameter anchor bolts in bottom track at 2'-8" on center with minimum of two bolts per length of wall. Alternately, PAF anchorage specified by the stud engineer is acceptable.

STEEL NOTES

- Structural steel shall be finished as follows:
 - Non-fireproofed interior steel shall be shop painted with min. 1.5 mil dry film thickness of a rust inhibiting primer.
 - Unless noted otherwise, exterior exposed steel, including veneer relief angles & bike storage framing, shall be:
 - Galvanized and prepared for paint
 - Refer to lintel schedule for finish requirements of lintels.
 - Coordinate metal deck attachment method with base material shape and thickness (joist, beam, or truss). Alternately, the Construction Manager and Steel Subcontractor shall work together to ensure proper base materials are provided, such as steel joist top chord shapes, that are adequate for the preferred attachment method.
- Erector is to provide temporary bracing sufficient to hold frame in position until all construction necessary for building stability is complete.
- Beam and lintel bearing on concrete and masonry wall shall be 8" unless otherwise shown. Provide beam bearing plates and wall anchors as required.
- All bolted moment, brace frame, and truss connections shall be done with slip critical bolts including the gravity shear connection. Slip critical joints shall be prepared with a Class A faying surface, and oversized holes in slip critical joints may be used at the fabricator's option.
- Bolted connections not specified to be slip critical shall be tightened snug tight (all metal surfaces in contact).
- Where aluminum or steel will contact dissimilar metals, protect against galvanic action by painting contact surfaces with primer and applying sealant or tape, or by installing nonconductive spacers as recommended for this purpose.
- All gusset plates to be minimum 3/8" thick. Unless noted otherwise, all column and beam web stiffeners and gusset plates shall be 3/8" thick.
- Miscellaneous steel supplier shall submit shop drawings for all miscellaneous steel stairs, designed and sealed by an engineer registered in the state of Michigan, for review. Coordinate construction details and dimensions with architectural information. Coordinate and detail connections to the primary structural framing with the steel fabricator, and refer to the typical stair stringer/header support detail for support of the main stair elements at CMU or concrete walls.
- Unless otherwise shown on plans, provide lintels for masonry walls as follows:
 - For 6" Walls (2)L3-1/2x2-1/2x5/16, spans to 6'-0"
 - For each 4" of wall thickness:
 - (1)L3-1/2x31/2x1/4, SPANS TO 4'-0"
 - (1)L4x3-1/2x5/16, SPANS TO 4'-0"
 - (1)L5x3-1/2x5/16, SPANS TO 8'-0"

ENGINEERING DATA

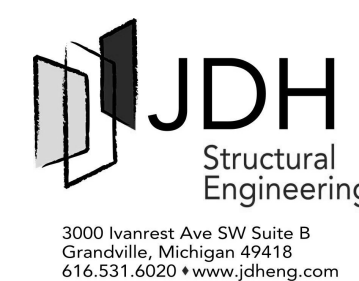
Design soil bearing pressure	Concrete	Helical piers @ building footings 15k Compression Allowable 10k Tension Allowable 1500 psf @ site footings
Design stresses	Concrete	Footings and Foundations Slabs on metal deck Interior structural slabs Exterior structural concrete (6% air) Reinforcing steel
	Steel	W shapes Rectangular HSS shapes (A500 Gr. C) Round HSS & Pipe shapes (A500) All other shapes Structural bolts Anchor bolts/Column anchor rods Welding electrode
	Masonry	CMU Grout Reinforcing steel
	Light Gauge Framing	Up to and including 43 mils 54 mils and thicker
	Metal Deck	Roof Deck 1.5B Non-Composite deck (for deck) 0.6C, 1.0C, & 1.3C Composite Deck 2VL/VLI
	Structural design requirements	Floor live load (LL reductions used where permitted by code) 1st floor 2nd floor Stairs
	Roof live load	20 psf
	Risk Category	II
	Roof snow load	Ground snow load (Pg) Flat roof snow load (Pf)
	Wind Load	Ultimate design wind speed (3 sec) Wind exposure category Internal pressure coeff (GCpi) Components & cladding (varies) Wall stud design pressure
	Earthquake	Seismic importance factor, Ie Spectral response
	Specific Design Loads	Roof dead loads (canopies) Roofing (Adhered) Insulation Metal deck Structure Ceiling M/E/P
		2 4 2 3 5 3 3 20 psf Total
		Roof dead loads (Bike storage) Roofing (Adhered) Metal deck Structure
		2 3 5 10 psf Total
	Design codes	General building code Concrete Steel
	Masonry	Cold Formed Metal Framing
		Michigan Building Code 2021 ACI 318 AISC 360 - ASD TMS 402/ACI 530/ASCE 5 AISI S100

CONCRETE MIX DESIGN PERFORMANCE SPECIFICATION TABLE (SHORT)

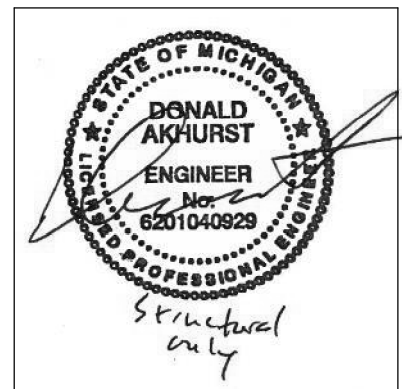
MIX TYPE	MIX DESCRIPTION	REQUIRED ADMIXTURES	REQUIRED SULFATE RESISTANCE (NOTE 6)	MINIMUM FREEZE-THAW RESISTANCE	PERMEABILITY & CHLORIDE RESISTANCE	MAXIMUM ALLOWED CHLORIDE ION CONTENT (% BY WEIGHT OF CEMENT)	MAXIMUM ALLOWED 28-DAY SHRINKAGE (%)	MINIMUM COMPRESSIVE STRENGTH F'c (PSI) (NOTE 3)	MAX W/CM RATIO (NOTE 2)	AIR CONTENT (% +/- 1.5%)	MAX AGG SIZE (IN)	FIBROUS REINF DOSAGE (LB/CY) (NOTE 7)
2	FOUNDATIONS, GRADE BEAMS, BASEMENT WALLS	25% FLY ASH OR 30% GROUND BLAST FURNACE SLAG IS ACCEPTABLE	S0	F1	C1	0.3	-	3500	0.55	4.5	1	0
5	INTERIOR STRUCTURAL SLAB (NOTE 4)	20% SCM RECOMMENDED	S0	F0	C0	1	0.04	3500	0.45	NA	1.5 (ENG NOTE 8)	1.5
11	NORMAL-WEIGHT CONCRETE ON METAL DECK		S0	F0	C0	0.3	0.05	4500	0.45	6	1	0
16	EXTERIOR STRUCTURAL CONCRETE (NOTES)		S1	F2	C0	0.3		4500	0.45	6	1	0

CONCRETE MIX DESIGN PERFORMANCE SPEC SCHEDULE NOTES:

- All aggregates shall be clean uniformly grades from coarse to fine.
- Water-reducing admixtures may be utilized to maintain water/cement ratio AND workability. Note that this may affect finish procedures.
- F'c values shown are code minimums. Engineering data may require a high F'c as dictated by project design requirements. Higher compressive strength requirement shall govern mix design.
- Coordinate admixtures and curing measures to be compatible with flooring materials and adhesives.
- Exterior Structural Concrete only covers concrete structures outside the building footprint shown on structural drawings. It does not include any other discipline, including Civil. Course aggregate for this mix shall be crushed limestone.
- See ACI 318 Table 19.3.2.1 for cementitious material restrictions, and Table 26.4.2.2(c) for maximum expansion strain limits.
- Fibrous reinforcement basis of design is fibrillated polypropylene micro-fibers engineered and designed for use in concrete, complying with ASTM C1116/C1116M, Type III, 1/2 to 1 1/2 inches long.
- See ACI 318 Table 26.4.2.2(b) for limits on cementitious materials for F3 exposure class.



City of Kalamazoo - Crosstown Facility
CPED & KDPS Workplace Renovation
150 E Crosstown Parkway Kalamazoo MI 49001



Bid Set 08/21/2025
ISSUE DATES

© 2024, intersect studio, llc
Project Number: 23-046

STRUCTURAL NOTES

S001

STRUCTURAL SPECIAL INSPECTION SCHEDULE (2021 IBC - Chapter 17)

ROW #	ITEM	CONT ²	PERIODIC ²	REFERENCE STANDARD	NOTES
1	PRE-FABRICATED CONSTRUCTION (1704.2.5)				3&4
2					
3	STRUCTURAL STEEL CONSTRUCTION (1705.2)				13
4	Verify Bolt, Nut & Washer Materials		X	ASTM specs/AISC 360 - A3.3	
5	Inspect Bearing-type Connections		X	AISC 360 - M2.5, Table N5.6 - 1/2/3	
6	Inspect Slip-critical Connections	X		AISC 360 - M2.5, Table N5.6 - 1/2/3	5
7	Verify Structural Steel Materials		X	ASTM A 6/ASTM A 568	
8	Verify Weld Filler Materials		X	AISC 360 - A3.5	
8	At all trusses, verify that permanent truss bracing is in accordance with approved building plans & BCSI 1-13.				
9	Partial / Complete Penetration Welds, Multipass Fillet Welds, Single-pass Fillet Welds > 5/16"	X		AWS D1.1	6&7
10	Single-pass Fillet Welds ≤ 5/16", Anchor / Stud Welds, Stair / Railing Welds		X	AWS D1.1	6
11	Inspect Steel Frame Joint Details		X		
12					
13	COLD FORMED STEEL DECK (1705.2.2)			SDI QA/QC, AWS: B5.1, D1.1, D1.3	
14	Verify compliance of deck and all deck accessories materials and installation with construction documents, including profiles. Verify deck materials are represented by the mill certifications that comply with the construction drawings		X	Applicable ASTM material standards	
15	Welding procedure specifications (WPS), manufacturer certifications for welding consumables and/or manufacturer installation instructions for mechanical fasteners available		X		
16	Material identification (type/grade)		X		
17	Check welding equipment and/or proper tools available for fastener installation and proper storage for mechanical fasteners		X		
18	Use of qualified welders, WPS followed, environmental conditions and control and handling of consumables		X		
19	Fasteners are positioned as required and installed in accordance with manufacturer's instructions		X		
20	Verify size and location of welds, including support, sidelap and perimeter welds. Welds meet visual acceptance criteria		X		
20	Check spacing, type and installation of support, sidelap and perimeter fasteners		X		
20	Verify repair activities		X		
21					
28	CONCRETE CONSTRUCTION (1705.3)			ACI 318: Ch. 26	9
29	Inspect reinforcement, including prestressing tendons, and verify placement		X	ACI 318: Ch. 20, 25.2, 25.3, 26.6.1 - 26.6.3, 26.13	
30	Welding of Reinforcing Steel			AWS D1.4/ACI 318: 26.6.4, 26.13	8
31	Verification of weldability of reinforcing steel other than ASTM A 706		X	AWS D1.4/ACI 318 - 26.6, 26.13	
32	Reinforcing steel resisting flexural and axial forces in intermediate and special moment frames, and boundary elements of special structural walls of concrete and shear reinforcement.	X		AWS D1.4/ACI 318 26.6	
33	Shear reinforcement	X		AWS D1.4/ACI 318 26.6	
35	Other reinforcing steel		X	AWS D1.4/ACI 318 - 26.6, 26.13	
36	Embedded Bolts & Plates		X	ACI 318: 17.8.2, 26.13	
37	Verify Required Mix Design		X	ACI 318: Ch 19, 26.4.3, 26.4.4, 26.13 IBC: 1904.1, 1904.2	
38	Prior to concrete placement, fabricate specimens for strength tests, perform slump and air content tests, and determine the temperature of the concrete	X		ASTM C 172/ASTM C 31/ACI 318:26.5, 26.12, 26.13	
39	Concrete/Shotcrete Placement	X		ACI 318: 26.4, 26.5, 26.13 IBC: 1908	
40	Curing temperatures and techniques		X	ACI 318: 26.5.3 - 26.5.5, 26.13 IBC: 1908.9	
44	Verify In-Situ Strength		X	ACI 318: 26.11.2, 26.12, 26.13	10
45	Formwork Shape, Location & Dimensions		X	ACI 318: 26.11.1.2(b), 26.13	
46	Post-Installed Anchor Placement			ACI 318: 17.8.2.4, 17.8.2, 26.13	11
47	Retaining Walls Bent Dowels Placement and Projection	X			
48					
60	MASONRY CONSTRUCTION (1705.4)			TMS 402/TMS 602/ACI 530/ASCE 5/ASCE 6	15,16
61	Proportions of Site-Prepared Mortar / Grout		X	TMS 602 - ART. 2.1, 2.6A, 2.6B, 2.6C 2.4G, 1.b	
62	Mortar Joint Construction		X	TMS 602 - ART. 3.3B	
63	Reinforcement / Connector Placement		X	TMS 402 - SEC. 6.1, 6.2.1, 6.2.6, 6.1.7 & TMS 602 - ART. 3.2E, 3.4, 3.6A	
64	Size & Location of Structural Elements		X	TMS 602 - ART. 3.3F	
65	Type, Size & Location of Anchors		X	TMS 402 - SEC. 1.2.1(e), 6.2.1, 6.3.1 & TMS 602 3.2E, 3.4	
66	Size, Grade & Type of Reinforcement		X	TMS 402 - SEC. 6.1 & TMS 602 - ART. 2.4, 3.4, 3.6A	
67	Hot or Cold Weather Protection		X	TMS 602 ART. 1.8C, 1.8D	
68	Verify Clean Grout Space		X	TMS 602 ART 3.2D, 3.2F	
69	Grout Placement	X		TMS 602 ART 3.5	
70	Observe Preparation of: Test Specimens /Prisms		X	TMS 602 ART 1.4B.2.a.3, 1.4B.2.b.3, 1.4B.2.c.3, 1.4B.3, 1.4B.4	
71	Compliance w/ Const. Docs & Submittals		X	TMS 602 ART 1.5	
81					
117	SOILS (1705.6)				12
118	Verify materials below shallow foundations are adequate to achieve the design bearing capacity		X		
119	Verify excavations are extended to proper depth and have reach proper material		X		
120	Perform classification and testing of compacted fill materials		X		
121	During fill placement, verify use of proper materials and procedures in accordance with the provisions of the approved geotechnical report. Verify densities and lift thicknesses during placement and compaction of compacted fill	X			
122	Prior to placement of compacted fill, observe subgrade and verify that site has been prepared properly		X		
125					
126	DEEP FOUNDATION ELEMENTS (1705.7, 1705.8, 1705.9)				
127	Inspect drilling operations and maintain complete and accurate records for each element		X		
128	Cast-in-place. Verify placement locations and plumbness, confirm element diameters, bell diameters (if applicable), lengths, embedment in bedrock (if applicable), and adequate end bearing strata capacity. Record concrete or grout volumes.		X		
129	Helical Piers: Verify equipment used, pile dimensions, tip elevations, final depth and final installation torque		X		
130	For concrete elements, perform tests and additional special inspections in accordance with Section 1705.3				
131	For steel elements, perform tests and additional special inspections in accordance with section 1705.2				
132					

STRUCTURAL SPECIAL INSPECTION SCHEDULE NOTES:

- Items marked with an 'X' shall be inspected in accordance with chapter 17 of the building code by a certified special inspector from an established testing agency. For material sampling and testing requirements, refer to the project specifications and the specific general notes, sections. The testing agency shall send copies of all structural testing and inspection reports directly to the architect, engineer, contractor, and building official. Any items which fail to comply with the approved construction documents shall immediately be brought to the attention of the contractor for correction. If discrepancies are not corrected, they shall be brought to the attention of the building official, architect, and engineer prior to completion of that phase of the work. Special inspection testing requirements apply equally to all bidder designed components.
- Continuous special inspection means the full-time observation of work requiring special inspection by an approved special inspector who is present in the area where the work is being performed. Periodic special inspection means the part-time or intermittent observation of work requiring special inspection by an approved special inspector who is present in the area where the work has been or is being performed and at the completion of the work. (sect 1702)
- Special inspection is not required for work performed by an approved fabricator per section 1704.2.5.1.
- Inspection for pre-fabricated construction shall be the same as if the material used in the construction took place on site. Continuous inspection will not be required during pre-fabrication if the approved agency certifies the construction and furnishes evidence of compliance.
- Slip-critical connections may have periodic special inspection provided that direct tension indicators, twist-off bolts, or turn-of-the-nut method with match marking techniques are used.
- All welds shall be visibly inspected.
- All complete penetration welds shall be tested ultrasonically or by using another approved method.
- Periodic special inspection is allowed for verification of the weldability of reinforcing steel other than ASTM A 706 and single pass fillet welds (maximum 5/16") in accordance with building code section 1705.3.1. Continuous special inspection is required for inspection of all other welds not included in the periodic special inspection requirements noted above.
- Special inspection is not required for isolated spread footings (≤ 3 stories), non-structural slabs, foundation walls, patios, driveways and sidewalks provided the requirements of section 1705.3 are met.
- Periodic special inspection is required for verification of in-situ concrete strength for post-tensioned concrete prior to tensioning tendons and for beams and structural slabs before removing shoring or forms.
- Continuous special inspection is required for adhesive anchors installed in horizontally or upwardly inclined orientations to resist sustained tension loads in accordance with building code section 1705.3. Periodic special inspections is allowed for mechanical anchors and adhesive anchors not defined in the continuous special inspections requirements noted above. Post-installed anchors into masonry or concrete may be used only when approved by architect and/or engineer using an approved product with current published ICC-ES research report issued by an approved source in accordance with 17.8.2 in ACI318 or other qualification procedures.
- Special inspection of soils shall reference the approved soils report to determine compliance.
- Special inspection for structural steel shall be per AISC 303, Section 8 or the project contract documents, whichever is more stringent.
- Any construction or material that has failed inspection shall be subject to removal and replacement.
- UNO, reference masonry standards are TMS 402/ACI 530/ASCE 5 and TMS 602/ACI 530.1/ASCE 6.
- MINIMUM TESTS:
 - Verification of Slump flow and Visual Stability Index (VSI) as delivered to the project site in accordance with TMS 602 Specification Article 1.5B.1.b.3 for self-consolidation grout. Verification of f'm and f'FAAC in accordance with TMS 602 Specification Article 1.4B prior to construction, except where specifically exempted by this code.
- This table and notes represent code requirements for structural portions of the project and is not a complete representation of what may be required by chapter 17 of the building code. See chapter 17 and project specifications for additional requirements.

REINFORCEMENT DEVELOPMENT AND LAP SPLICE LENGTH - HORIZONTAL TOP BARS- UNCOATED

BAR SIZE	DEVELOPMENT LENGTH (l _D)		LAP SPLICE LENGTH	
	CASE 1	CASE 2	CASE 1	CASE 2
#3	19"	28"	25"	37"
#4	25"	37"	33"	49"
#5	31"	47"	41"	61"
#6	37"	56"	49"	73"
#7	54"	81"	71"	106"
#8	62"	93"	81"	121"
#9	70"	105"	91"	136"
#10	79"	118"	102"	153"
#11	87"	131"	114"	170"

REINFORCEMENT DEVELOPMENT AND LAP SPLICE LENGTH - VERTICAL BARS AND HORIZONTAL BOTTOM BARS- UNCOATED

BAR SIZE	DEVELOPMENT LENGTH (l _D)		LAP SPLICE LENGTH	
	CASE 1	CASE 2	CASE 1	CASE 2
#3	15"	22"	19"	28"
#4	19"	29"	25"	37"
#5	24"	36"	31"	47"
#6	29"	43"	37"	56"
#7	42"	63"	54"	81"
#8	48"	72"	62"	93"
#9	54"	81"	70"	105"
#10	61"	91"	79"	118"
#11	67"	101"	87"	131"

REINFORCEMENT DEVELOPMENT AND LAP SPLICE LENGTH NOTES:

- HORIZONTAL BOTTOM BARS ARE HORIZONTAL BARS SO PLACED THAT 12" OR LESS OF FRESH CONCRETE IS CAST IN THE MEMBER BELOW THE DEVELOPMENT LENGTH OR SPLICE.
- HORIZONTAL TOP BARS ARE HORIZONTAL BARS SO PLACED THAT MORE THAN 12" OF FRESH CONCRETE IS CAST IN THE MEMBER BELOW THE DEVELOPMENT LENGTH OR SPLICE.
- CASE 1: CLEAR SPACING OF BARS BEING DEVELOPED OR SPLICED NOT LESS THAN db, CLEAR COVER NOT LESS THAN db, AND STIRRUPS OR TIES THROUGHOUT l_D NOT LESS THAN THE CODE MINIMUM OR CLEAR SPACING OF BARS BEING DEVELOPED OR SPLICED NOT LESS THAN 2db AND CLEAR COVER NOT LESS THAN db.
CASE 2: OTHER CASES
CASE 3: EPOXY COATED REINFORCEMENT WITH COVER LESS THAN 3db, OR CLEAR SPACING LESS THAN 6db.
- MULTIPLY VALUES SHOWN BY 1.3 FOR LIGHTWEIGHT CONCRETE.

WALL FOOTING SCHEDULE 1

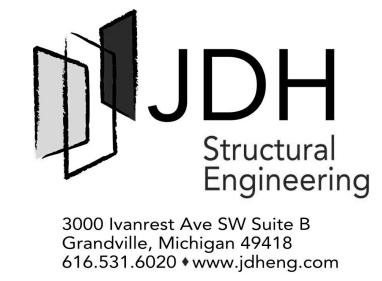
MARK	LONGITUDINAL REINFORCING	TRANSVERSE REINFORCING	DOWELS (NOTE 2)	NOTE / DETAIL
WF3615	(3)#5	#4 @ 12"		13/S201

WALL FOOTING SCHEDULE NOTES:

- WALL FOOTING SCHEDULE APPLIES TO INTERIOR AND EXTERIOR FOUNDATIONS. SEE PLANS AND DETAILS FOR ADDITIONAL INFORMATION.

FOOTING SCHEDULE

MARK	WIDTH	LENGTH	THICKNESS	REINFORCING EW	NOTES
F3.67	3' - 8"	3' - 8"	42"		EXISTING
F4x2	2' - 0"	4' - 0"	42"		EXISTING
F5.0	5' - 0"	5' - 0"	15"	(7) #4	



3000 Ivarrest Ave SW Suite B
Grandville, Michigan 49418
616.531.4020 • www.jdheng.com



City of Kalamazoo - Crosstown Facility
CPED & KDPS Workplace Renovation
150 E Crosstown Parkway Kalamazoo MI 49001



Bid Set 08/21/2025
ISSUE DATES
© 2024, intersect studio, llc
Project Number: 23-046

STRUCTURAL SCHEDULES

S002



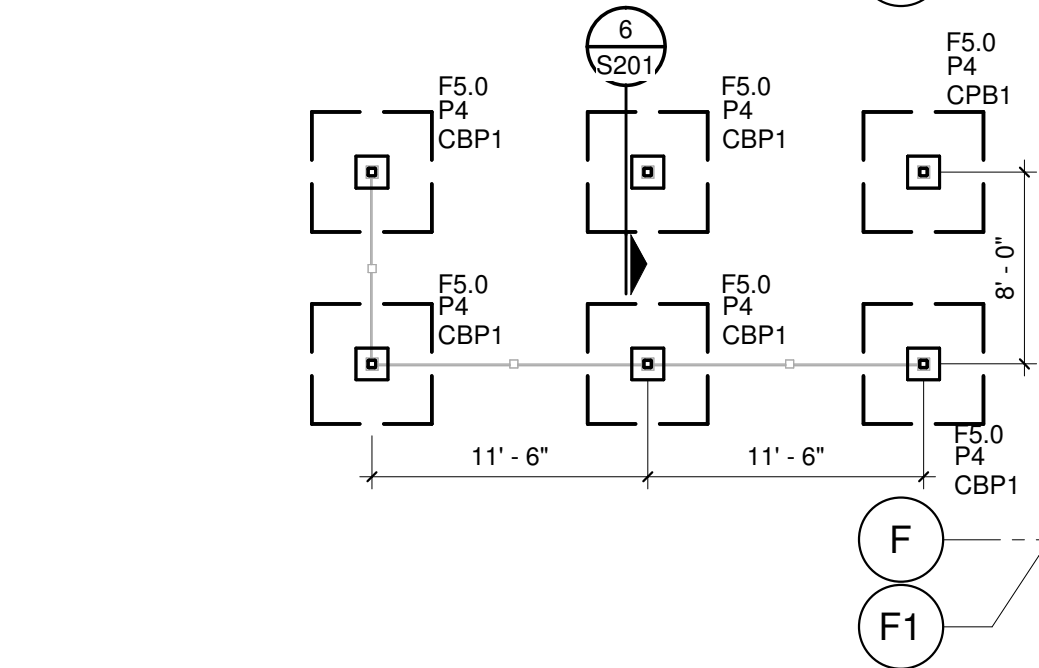
FOUNDATION PLAN NOTES

- Wall footing callout example is as follows:
WF1812
- Footing width "W" in inches Footing thickness "T" in inches
- See plan for actual sizes. See foundation details for additional information, including reinforcing and dowels.
- Top of slab elevation = 100'-0" (match existing) unless noted thus (xx'-x") on plan. Slab shall slope uniformly between points of unequal elevation.
 - UNO on plan, slab on grade (SOG) shall be a structural slab as noted.
 - Top of interior footing elevation = 99'-4" unless noted thus (xx'-x") on plan.
 - Top of pile cap elevation = 96'-4" unless noted thus (xx'-x") on plan. Top of footing elevation = 97'-6" unless noted thus (xx'-x") on plan.
 - Top of pier elevation = 99'-0" unless noted thus (xx'-x") on plan.
 - Top of wall elevation see details.
 - Footings shall be centered under columns and walls unless detailed or dimensioned otherwise.
 - Refer to architectural drawings for all dimensions not indicated.
 - Refer to architectural drawings for all slab recesses.
 - Where structures are supported on spread footings they are to be isolated from the main building by either an expansion joint or other isolation material to keep the two structures from binding together.
 - Remove and replace 12"x12" concrete pocket for new column to sit on existing grade beam. Top of grade beam 8" +/- BFF.
 - Take site wall footing over top of pile caps, and but into pier. At interface between wall & footing provide 30# building paper bond breaker. Also provide similar breaker at all curb to building/piers.
 - Structural slab plumbing penetrations:
 - Field locate all existing reinforcing bar locations by non-destructive test methods.
 - Removed concrete without cutting any reinforcing bars.
 - Any opening within the slab shall be outside the column bands which is approximately 8'-0" clear each way of every column line (vertical and horizontal).
 - The condition of the soil below the slab is unknown. It is recommended that a 24"x24" test hole be made to determine soil location below the slab, compaction, and bearing capacity.
 - Limit loading on slab within 20'-0" of access area to 20 psf live load until the concrete has been replaced and obtained 90% of compressive strength.
 - Any underground piping shall be done bore below the slab through 24"x24" access hole to 24"x24" access hole.
 - When replacing slab clean the face of all existing slabs and rebar, and then apply bonding agent to concrete.
 - Construction loading on the slab shall be limited to 100 psf live load or a 2000# equipment load.
 - Provide 14"x14" lightpole pier w/ (4) #6 verticals & #3 ties @ 12" oc group top (6) @ 3".

HELICAL PIER NOTES

- Helical piers shall be installed with a tolerance of 1" or less from locations shown. Piers installed outside of that tolerance will require additional piers.
- Contractor to hold a contingency for re-engineering piers and caps to correct misplaced helical piers.
- During pier installation if obstructions are encountered which will prevent installation of pier to required depth, notify A/E with corrective method. The contractor shall provide 3 copies of installation records, showing location, date, length, torque value, and final tip elevation.
- Contractor to provide sealed calculations and layouts for the delegated design and engineering required for all helical piers.
- Foundations are designed for an allowable compressive load of 15 kips per helical pier, and an allowable tension load of 10 kips.
- All helical piers to have a minimum ultimate compressive capacity of 30 kips, and an ultimate tension capacity of 30 kips.

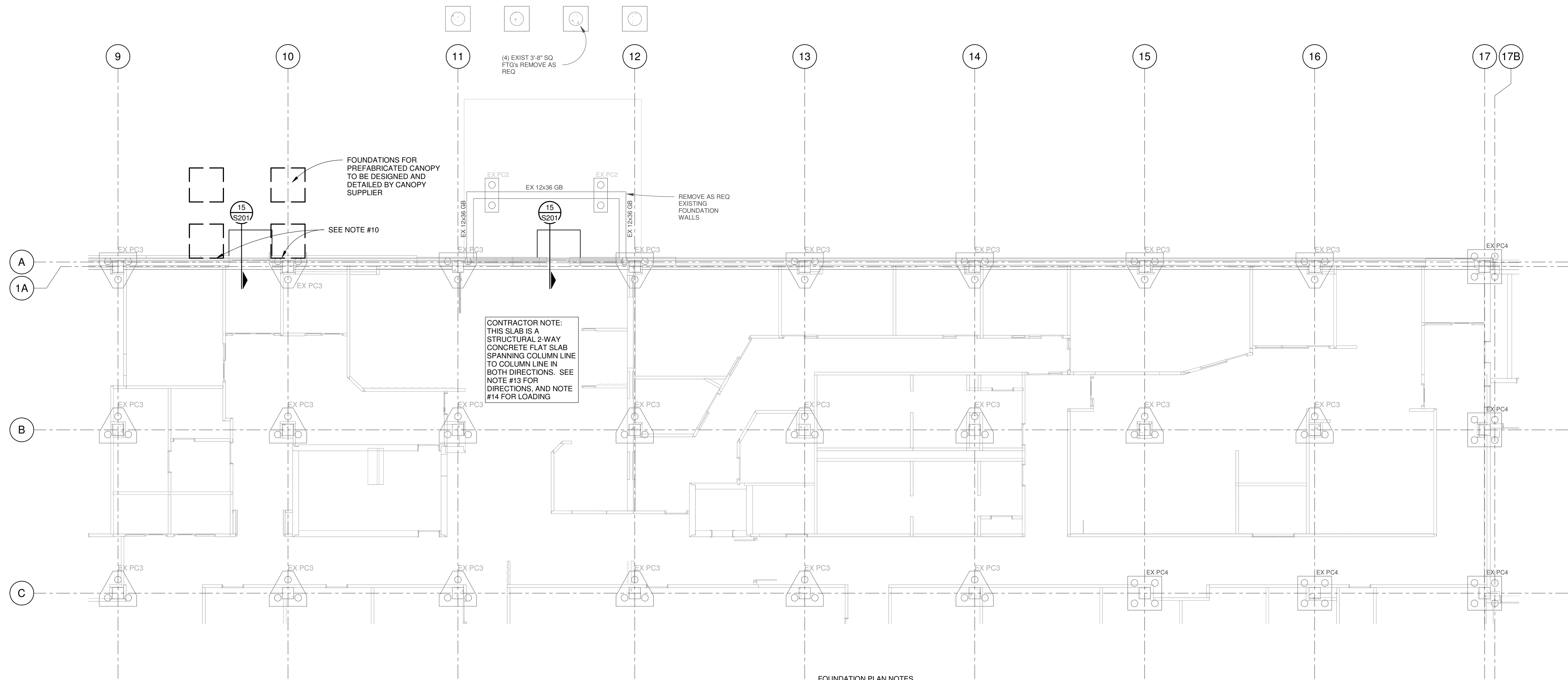
EXISTING BUILDING NOTE:
THIS PROJECT IS AN ADDITION AND RENOVATION OF AN EXISTING BUILDING. THE DRAWINGS REFLECT WHAT IS KNOWN ABOUT THE EXISTING BUILDING, BUT EXISTING CONDITIONS MUST BE VERIFIED BEFORE FABRICATION AND CONSTRUCTION. ABUTTING CONSTRUCTION MUST MATCH UP. VERIFY ALL SUCH CONDITIONS, AND NOTIFY A/E IF ACTUAL CONDITIONS DIFFER FROM THE CONTRACT DOCUMENTS. AN ATTEMPT HAS BEEN MADE TO ANTICIPATE CONDITIONS IN THE EXISTING STRUCTURE.



**FOUNDATION PLAN -
ZONE A**
SCALE: 1/8" = 1'-0"



CONTRACTOR NOTE:
THIS SLAB IS A STRUCTURAL 2-WAY CONCRETE FLAT SLAB SPANNING COLUMN LINE TO COLUMN LINE IN BOTH DIRECTIONS. SEE NOTE #13 FOR DIRECTIONS, AND NOTE #14 FOR LOADING



FOUNDATION PLAN - ZONE B
SCALE: 1/8" = 1'-0"

Wall footing callout example is as follows:

WF1812

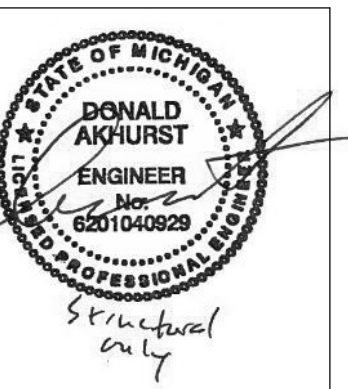
Footing width "W" in inches Footing thickness "T" in inches

See plan for actual sizes. See foundation details for additional information, including reinforcing and dowels.

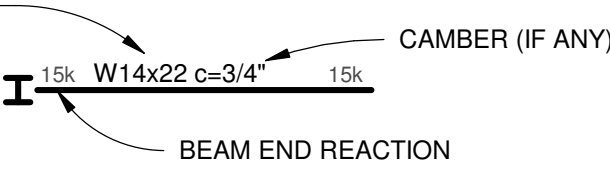
1. Top of slab elevation = 100'-0" (match existing) unless noted thus (xx'-x") on plan. Slab shall slope uniformly between points of unequal elevation.
2. UNO on plan, slab on grade (SOG) shall be a structural slab as noted.
3. Top of interior footing elevation = 99'-4" unless noted thus (xx'-x") on plan.
4. Top of pile cap elevation = 96'-4" unless noted thus (xx'-x") on plan. Top of footing elevation = 97'-6" unless noted thus (xx'-x") on plan. Top of pier elevation = 99'-0" unless noted thus (xx'-x") on plan.
5. Top of wall elevation see details.
6. Footings shall be centered under columns and walls unless detailed or dimensioned otherwise.
7. Refer to architectural drawings for all dimensions not indicated.
8. Where structures are supported on spread footings they are to be isolated from the main building by either an expansion joint or other isolation material to keep the two structures from binding together.
9. Remove and replace 12"x12" concrete pocket for new column to sit on existing grade beam. Top of grade beam 8" +/- BFF.
10. Take site wall footing over top of pile caps, and but into pier. At interface between wall & footing provide 30# building paper bond breaker. Also provide similar breaker at all curb to building/piers.
11. Structural slab plumbing penetrations:
 - A. Field locate all existing reinforcing bar locations by non-destructive test methods.
 - B. Removed concrete without cutting any reinforcing bars.
 - C. Any opening within the slab shall be outside the column bands which is approximately 8'-0" clear each way of every column line (vertical and horizontal).
 - D. The condition of the soil below the slab is unknown. It is recommended that a 24"x24" test hole be made to determine soil location below the slab, compaction, and bearing capacity.
 - E. Limit loading on slab within 20'-0" of access area to 20 psf live load until the concrete has been replaced and obtained 90% of compressive strength.
 - F. Any underground piping shall be done by bore below the slab through 24"x24" access hole to 24"x24" access hole.
 - G. When replacing slab clean the face of all existing slabs and rebar, and then apply bonding agent to concrete.
12. Construction loading on the slab shall be limited to 100 psf live load or a 2000# equipment load.
13. Provide 14"x14" lightpole pier w/ (4) #6 verticals & #3 ties @ 12" oc group top (6) @ 3'.

EXISTING BUILDING NOTE:

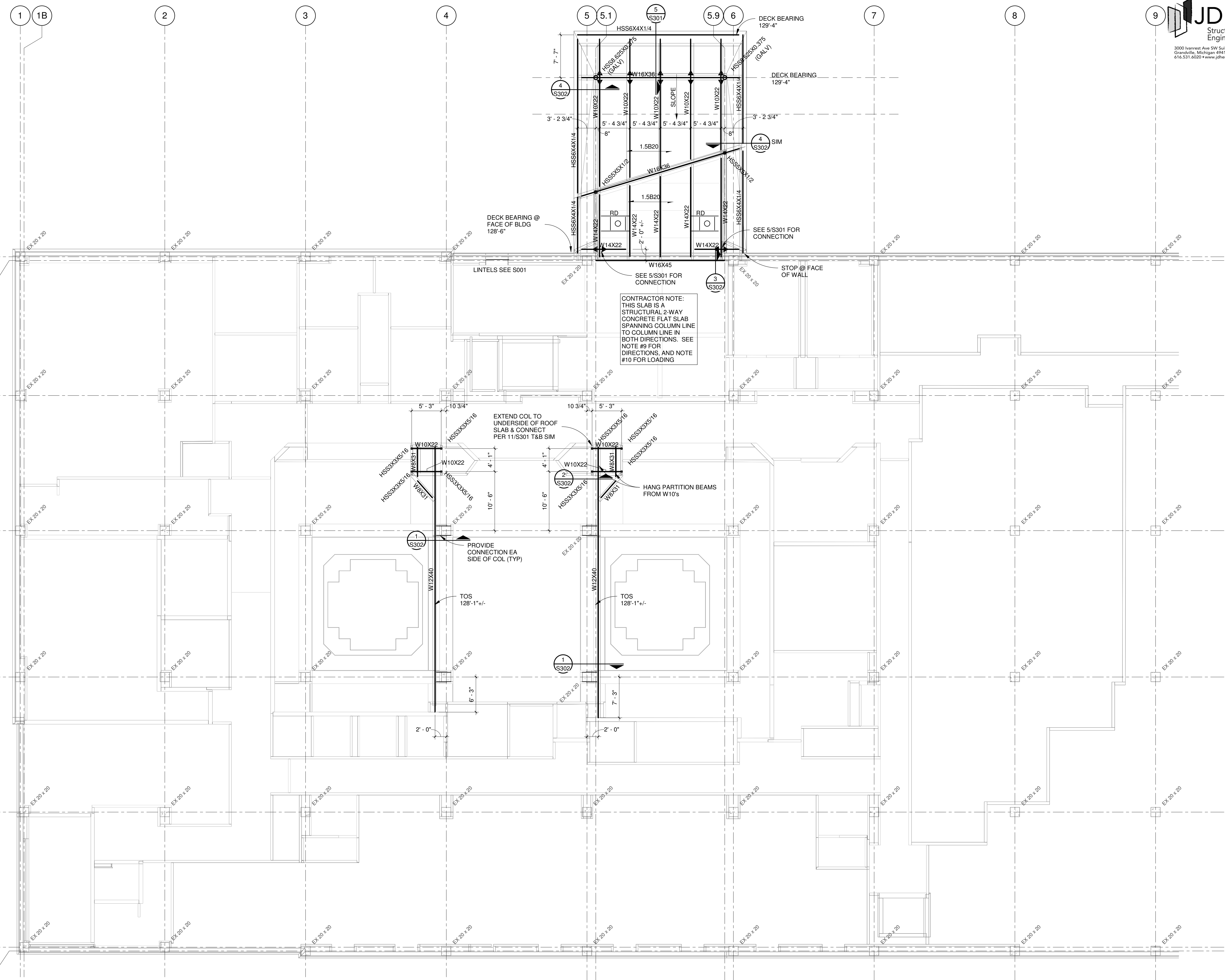
THIS PROJECT IS AN ADDITION AND RENOVATION OF AN EXISTING BUILDING. THE DRAWINGS REFLECT WHAT IS KNOWN ABOUT THE EXISTING BUILDING, BUT EXISTING CONDITIONS MUST BE VERIFIED BEFORE FABRICATION AND CONSTRUCTION. ABUTTING CONSTRUCTION MUST MATCH UP. VERIFY ALL SUCH CONDITIONS, AND NOTIFY A/E IF ACTUAL CONDITIONS DIFFER FROM THE CONTRACT DOCUMENTS. AN ATTEMPT HAS BEEN MADE TO ANTICIPATE CONDITIONS IN THE EXISTING STRUCTURE.



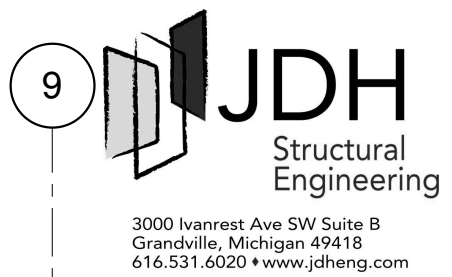
ROOF FRAMING PLAN NOTES

- Roof beam nomenclature is as follows:
- AISC STEEL DESIGNATION  CAMBER (IF ANY)
BEAM END REACTION
- Roof deck bearing elevation (DBE) = xxx'-x" unless noted thus (xxx'-x") on plan. Structure shall slope uniformly between points of unequal elevation.
 - Beams are equally spaced between grids or columns unless dimensioned otherwise.
 - Roof deck:
 - UNO, roof deck shall be galvanized metal deck, minimum 3 span continuous (or equivalent). Type and gauge of deck is as indicated below.
 - UNO, weld to supports shall be 5/8" puddle welds in a 3/4" pattern for 36" wide sheets. Alternate: Fasten with powder activated fasteners at the same spacing if permitted by joist supplier. Submit PAF size and type to A/E for review.
 - UNO, sidelap fasteners shall be #10 Buildex Traxx screws (or equivalent) between supports, spaced at 36" on center for spans over 5'-0" in length. No fasteners required for spans less than 5'-0".
 - UNO, at bearing ends of deck, weld deck edges to supports at each deck rib with 5/8" puddle weld.
 - UNO, at deck edges where deck runs parallel, provide (2) 5/8" puddle welds at each joist or beam. Where a continuous steel support has been provided, weld to supporting member with 5/8" puddle welds at 12" OC.
 - Lap ends of roof deck sheets 4" (min) over beams or joists.
 - Indicates beam to column or thru beam moment connection. MCxx refers to moment connection # - see details.
 - RD indicates roof drain see 3/S301 for framing.
 - Design beams w/o reaction identified on plan for vertical allowable load of 10k.
 - 1.5Bxx indicates 1-1/2" wide rib metal roof deck. xx indicates the gauge of the deck.
 - Structural slab penetrations & hanging supports:
 - Field locate all existing reinforcing bar locations by non-destructive test methods.
 - Removed concrete without cutting any reinforcing bars.
 - Any opening within the slab shall be outside the column bands which is approximately 8'-0" clear each way of every column line (vertical and horizontal).
 - Limit loading on slab within 20'-0" of access areas to 20 psf live load until the concrete has been replaced and obtained 90% of compressive strength.
 - All penetrations through the slab shall be located between reinforcing. If larger openings are required structural reinforcing may be required, and will be determined at that time.
 - When replacing slab clean the face of all existing slabs and rebar, and then apply bonding agent to concrete.
 - When hanging materials from the underside or connecting to the top of slab, drill pilot hole to locate reinforcing, and adjust anchor location to miss reinforcing. Design and selection of anchor for AMEP equipment to be performed by equipment supplier.
 - Construction loading on the slab shall be limited to 100 psf live load or a 2000# equipment load.

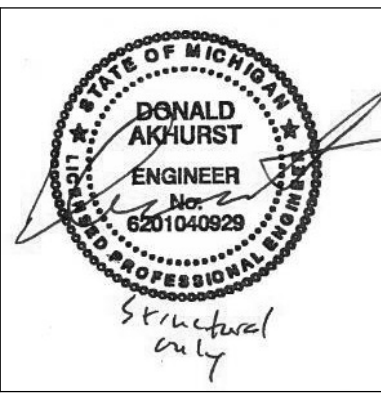
EXISTING BUILDING NOTE:
THIS PROJECT IS AN ADDITION AND RENOVATION OF AN EXISTING BUILDING. THE DRAWINGS REFLECT WHAT IS KNOWN ABOUT THE EXISTING BUILDING, BUT EXISTING CONDITIONS MUST BE VERIFIED BEFORE FABRICATION AND CONSTRUCTION. ABUTTING CONSTRUCTION MUST MATCH UP. VERIFY ALL SUCH CONDITIONS, AND NOTIFY A/E IF ACTUAL CONDITIONS DIFFER FROM THE CONTRACT DOCUMENTS. AN ATTEMPT HAS BEEN MADE TO ANTICIPATE CONDITIONS IN THE EXISTING STRUCTURE.



ROOF FRAMING PLAN - ZONE A
SCALE: 1/8" = 1'-0"



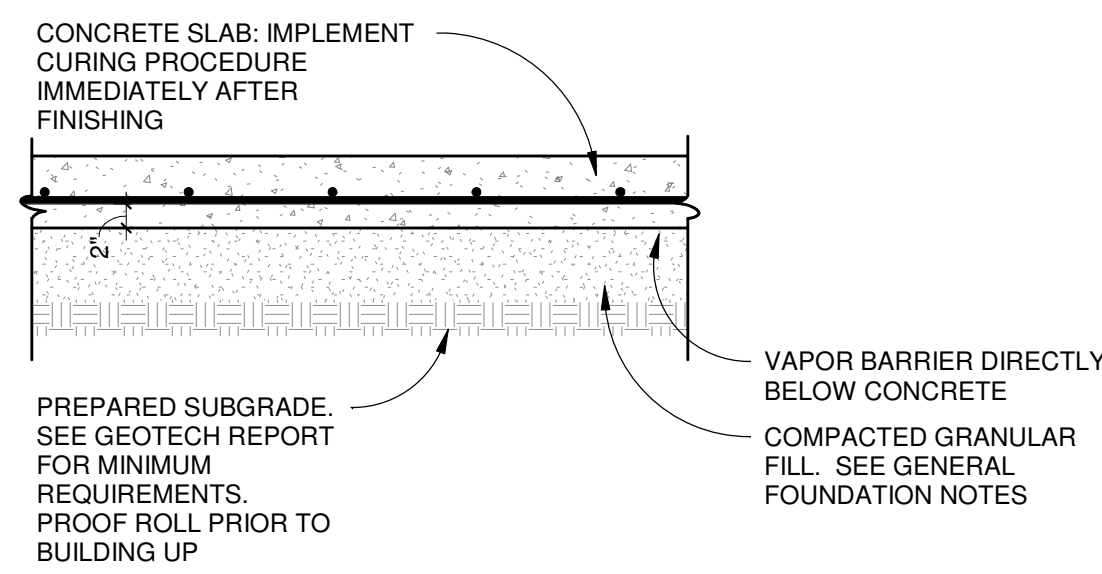
City of Kalamazoo - Crosstown Facility
CPED & KDPS Workplace Renovation
150 E Crosstown Parkway Kalamazoo MI 49001



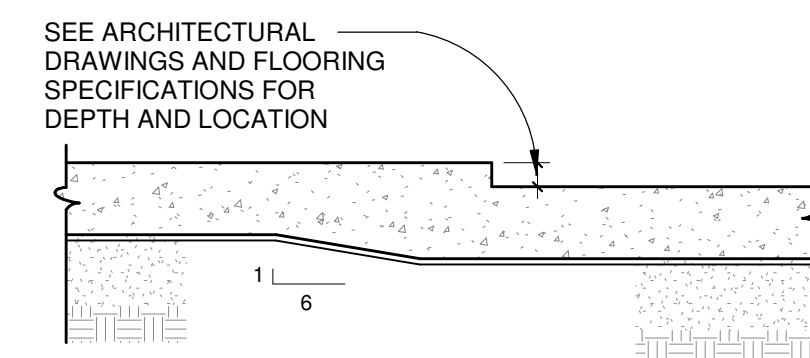
Bid Set 08/21/2025
ISSUE DATES
© 2024, intersect studio, llc
Project Number: 23-046

ROOF FRAMING PLAN - ZONE A

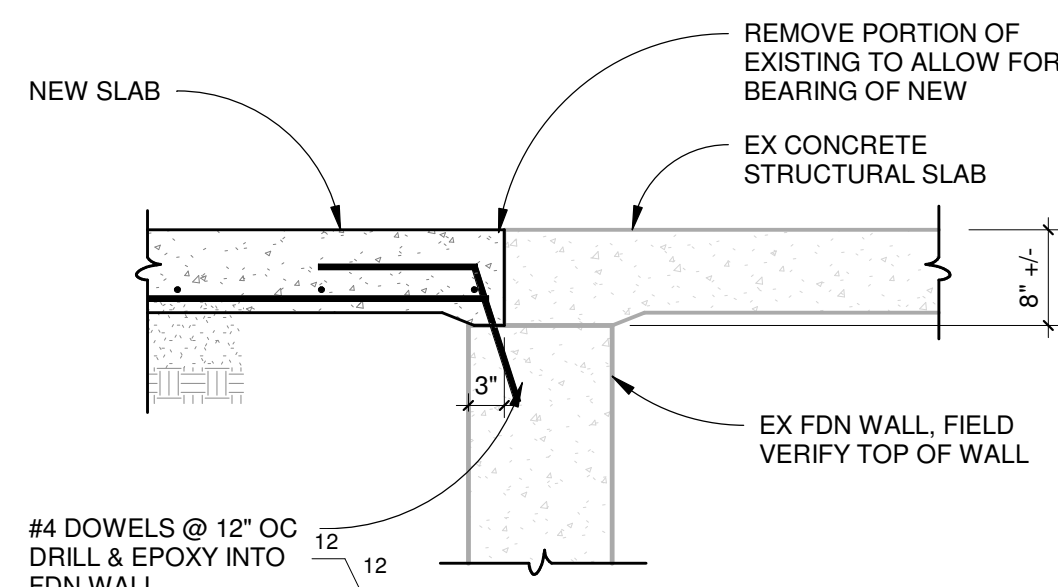
S104



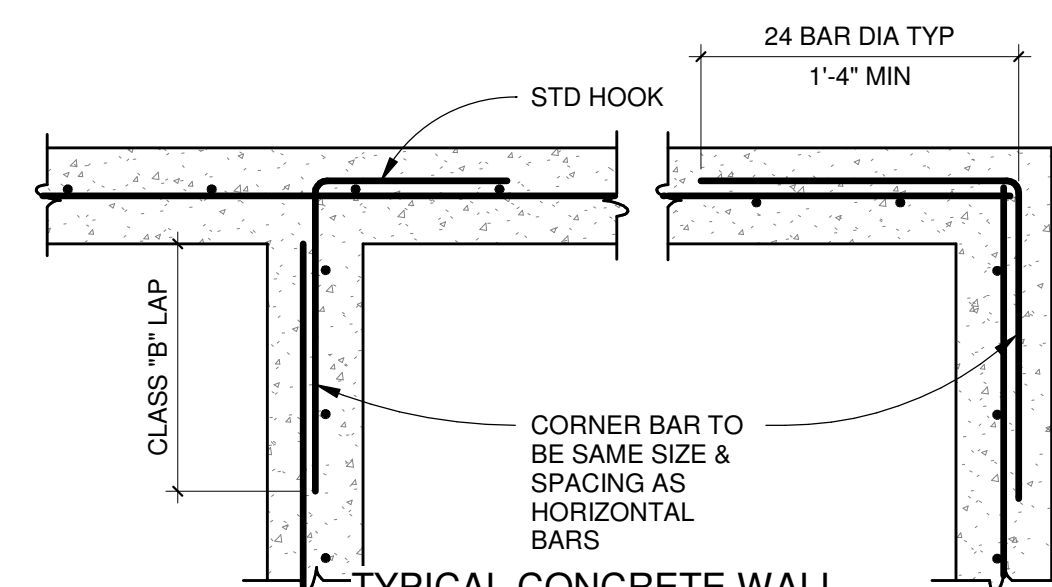
1
S201
TYPICAL SLAB ON GRADE CONSTRUCTION
SCALE: 3/4" = 1'-0"



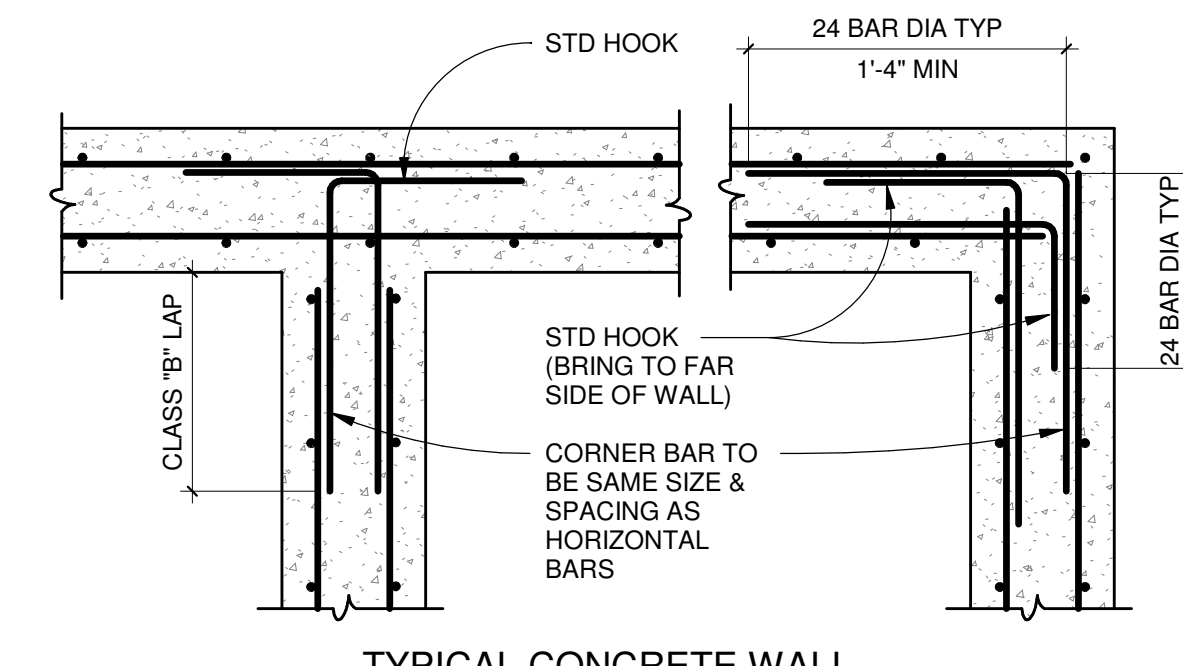
2
S201
TYPICAL RECESSED SLAB DETAIL
SCALE: 3/4" = 1'-0"



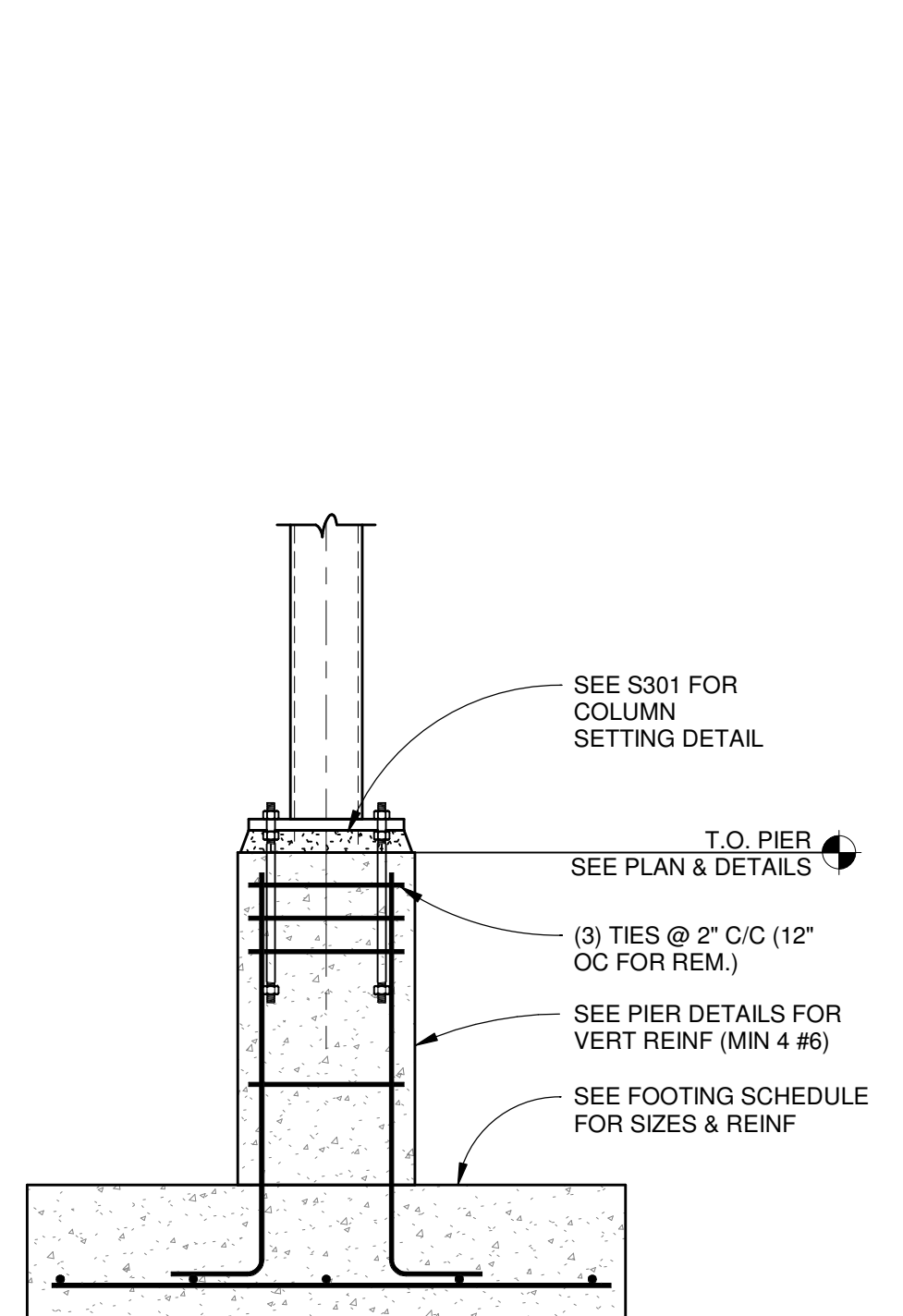
3
S201
DETAIL AT EXISTING WALL
SCALE: 3/4" = 1'-0"



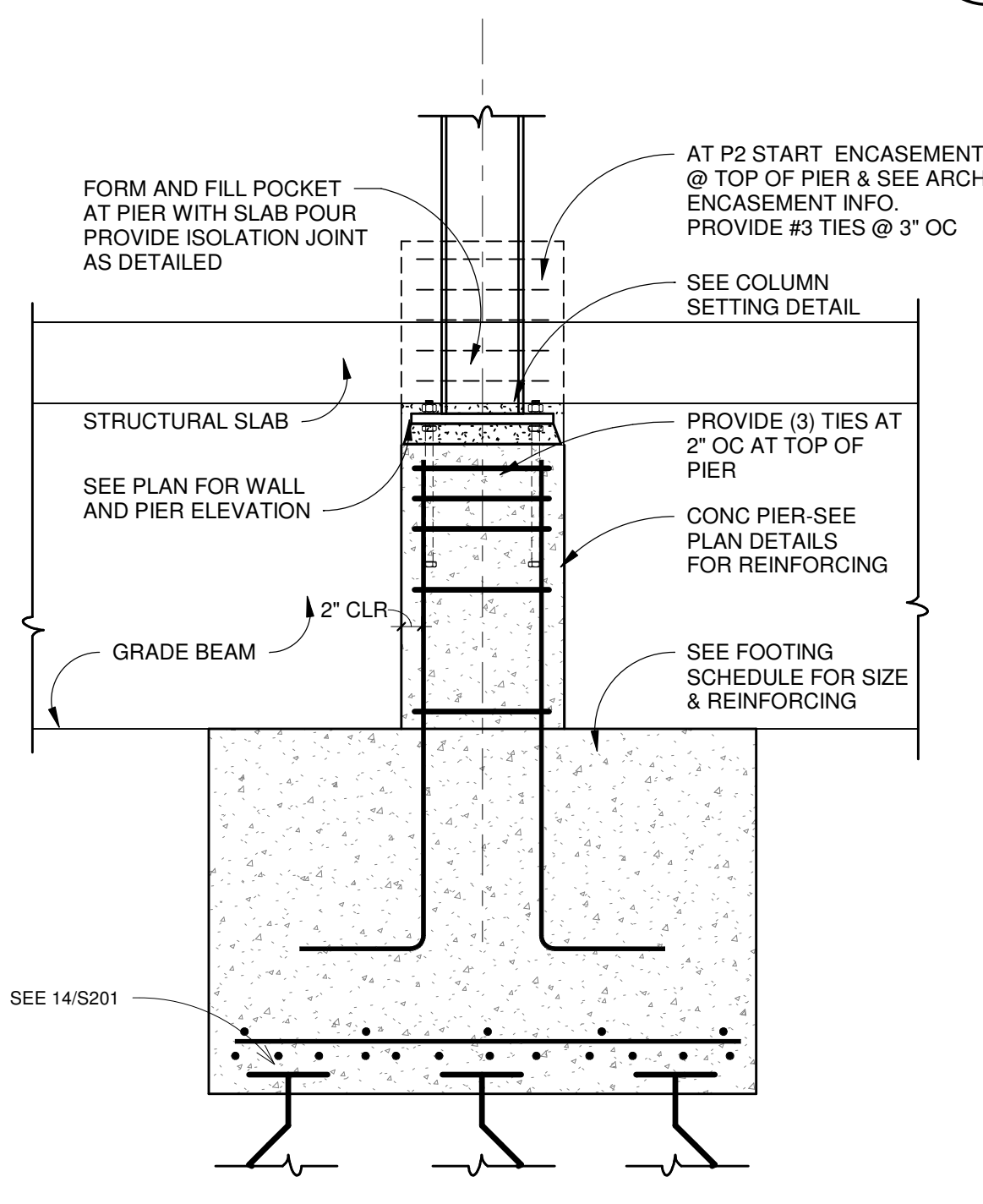
4
S201
TYPICAL CONCRETE WALL CORNER & INTERSECTION REINFORCING DETAILS W/ SINGLE REINFORCING
SCALE: 3/4" = 1'-0"



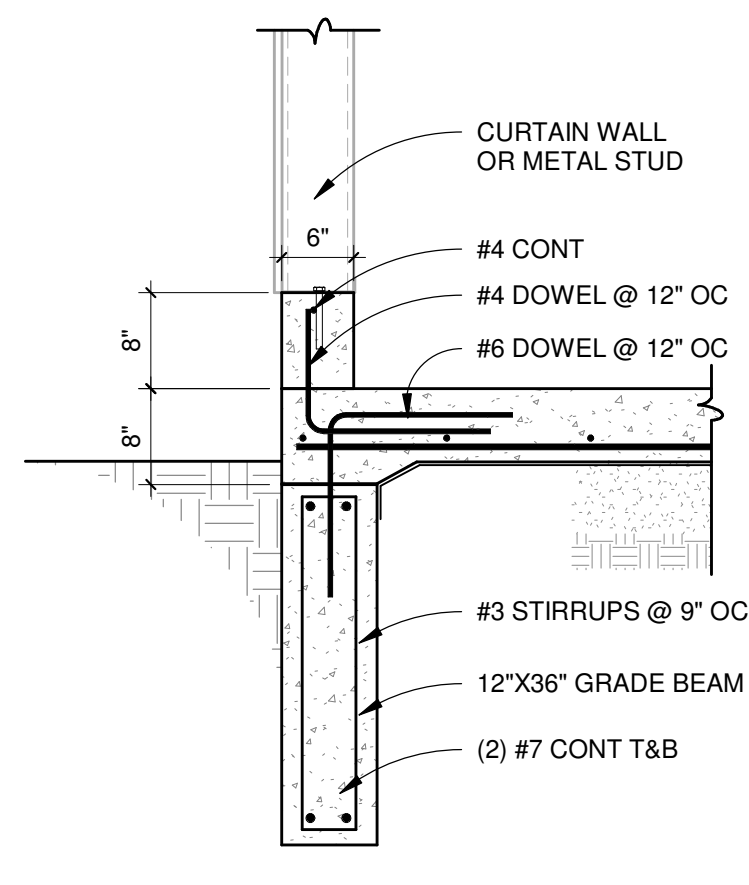
5
S201
TYPICAL CONCRETE WALL CORNER & INTERSECTION REINFORCING DETAILS W/ REINFORCING EA FACE
SCALE: 3/4" = 1'-0"



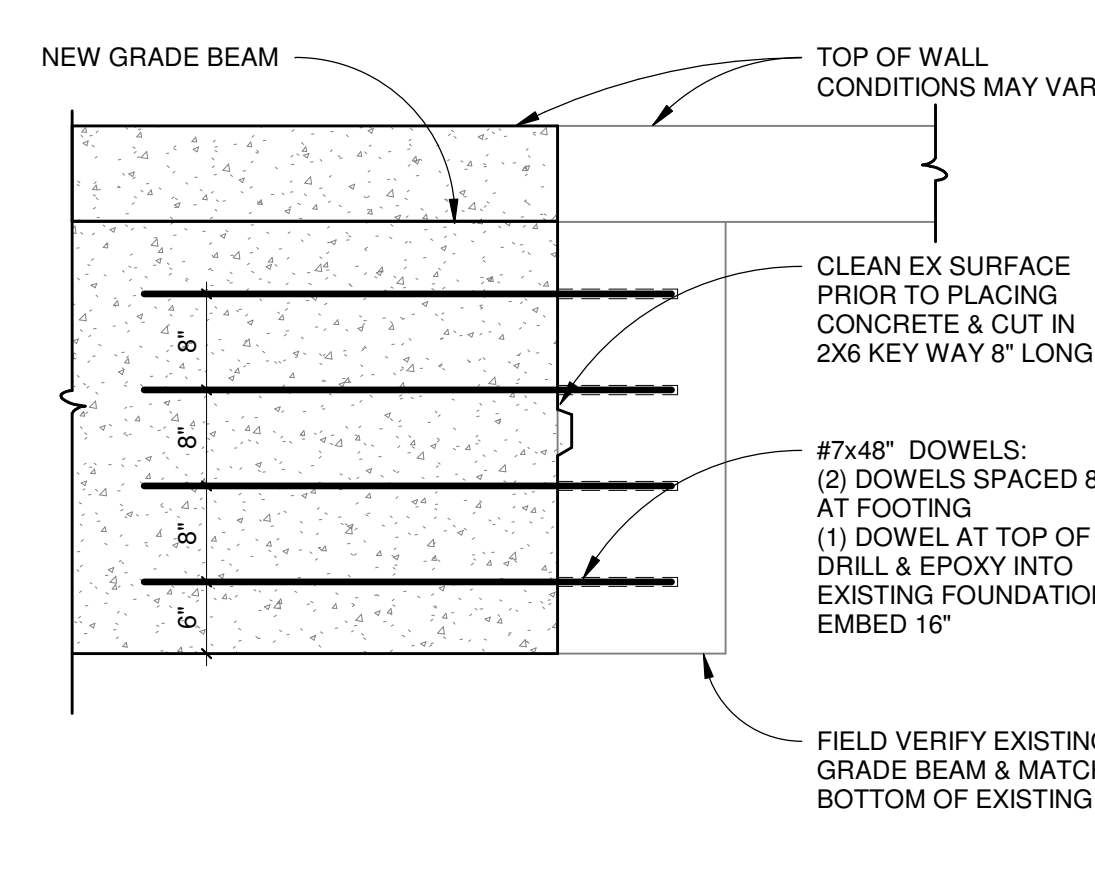
6
S201
PEMB COLUMN DETAIL
SCALE: 3/4" = 1'-0"



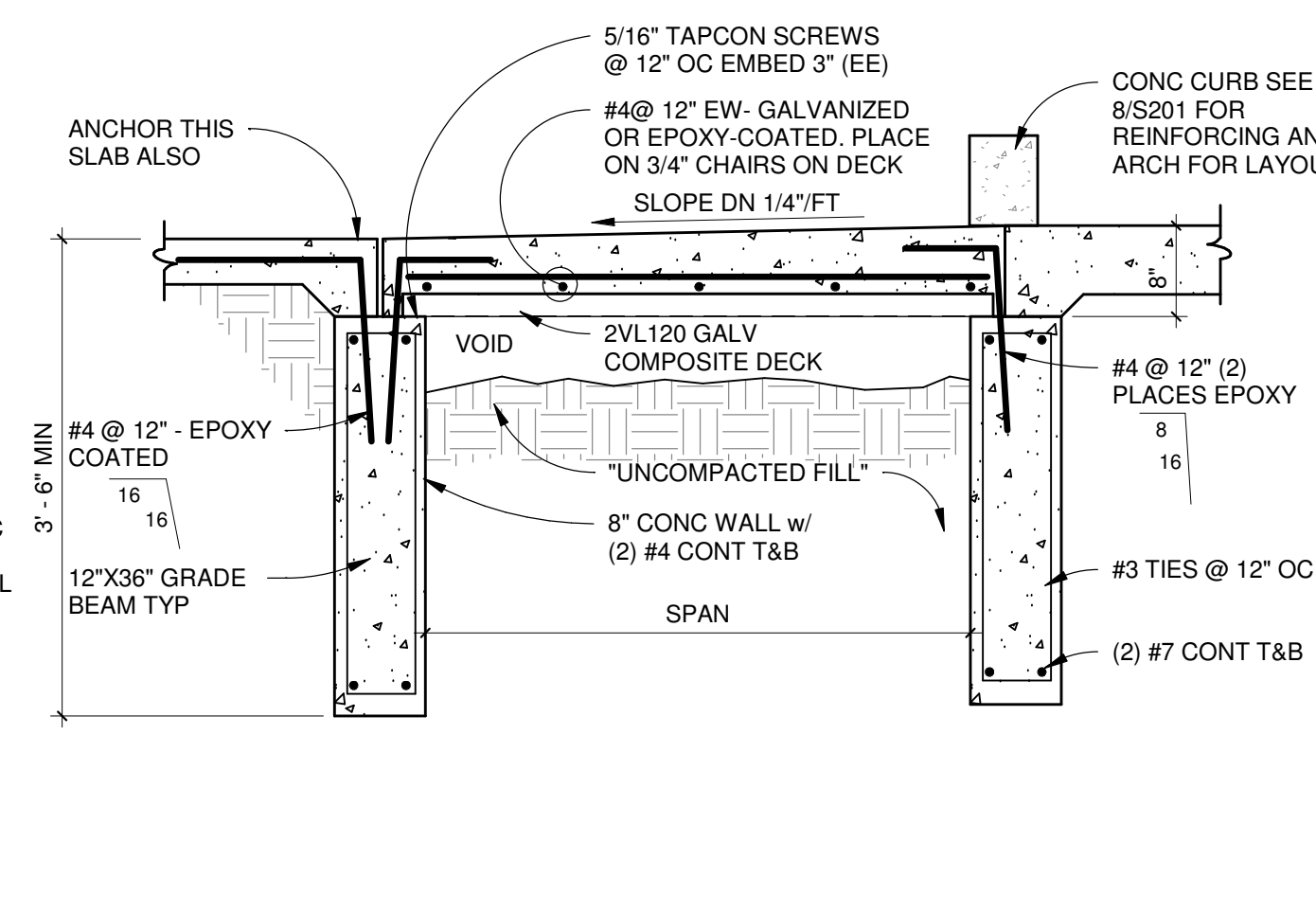
7
S201
TYPICAL EXTERIOR COLUMN PIER
SCALE: 3/4" = 1'-0"



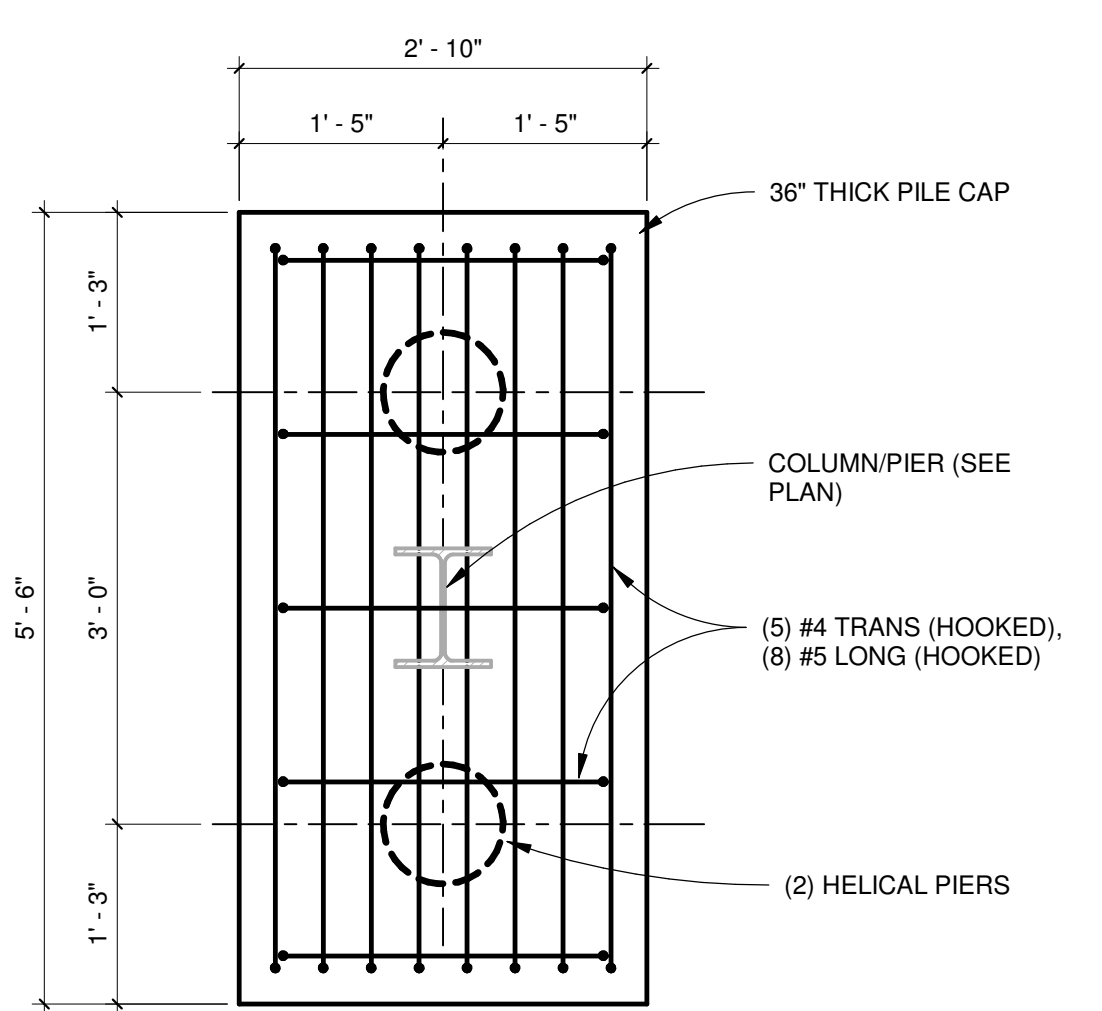
8
S201
TYPICAL EXTERIOR GRADE BEAM
SCALE: 3/4" = 1'-0"



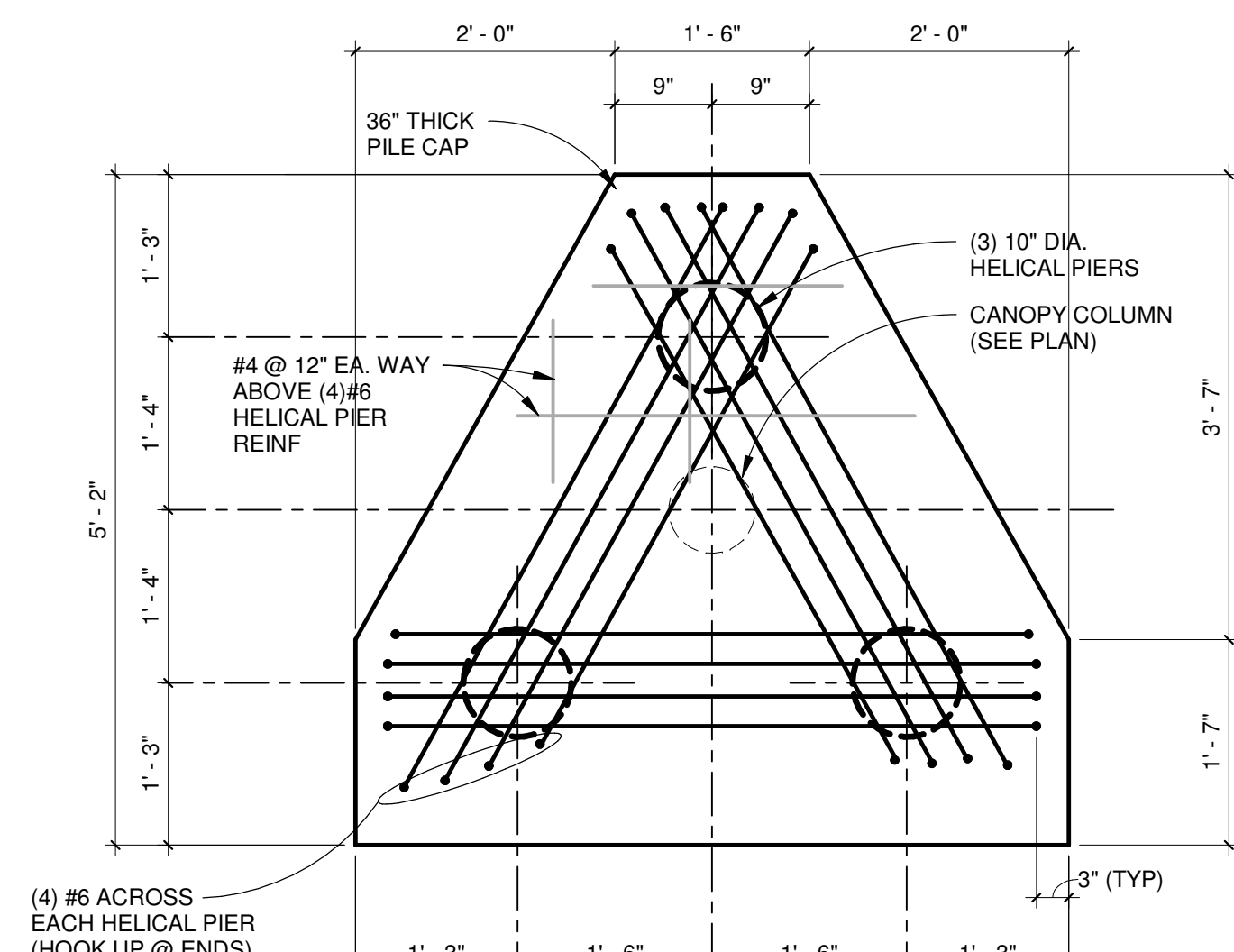
9
S201
FOUNDATION DETAIL AT EXISTING GRADE BEAM
SCALE: 3/4" = 1'-0"



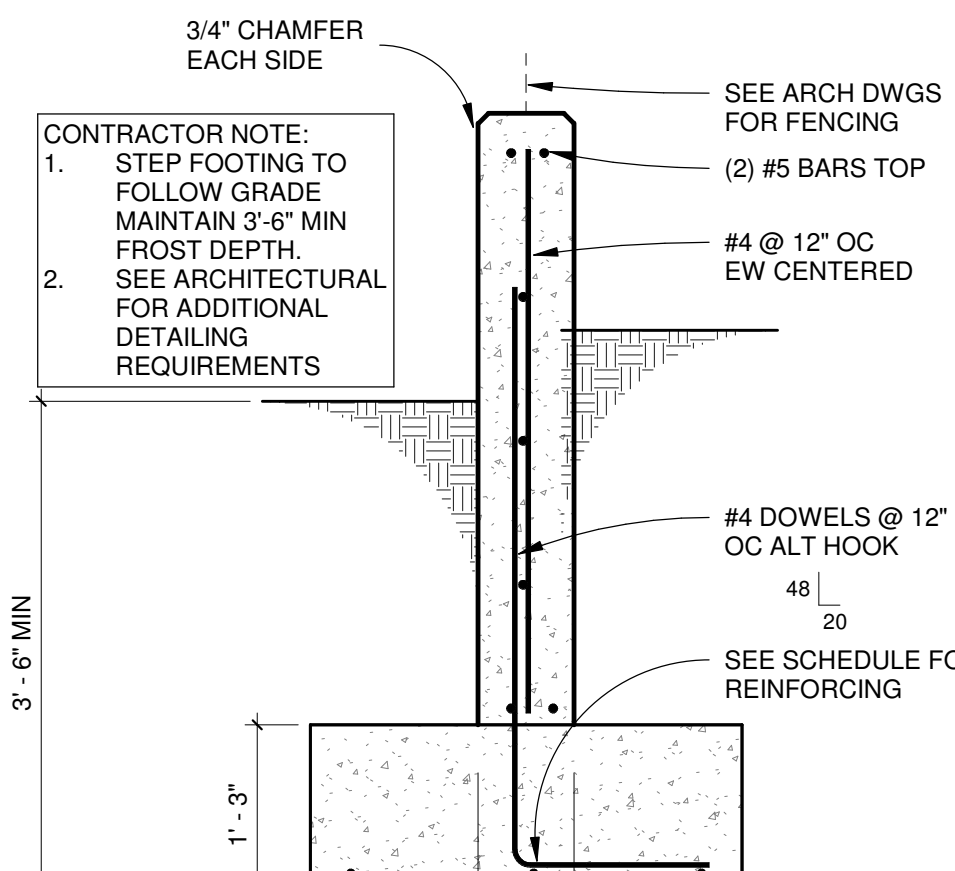
10
S201
THRESHOLD DETAIL
SCALE: 3/4" = 1'-0"



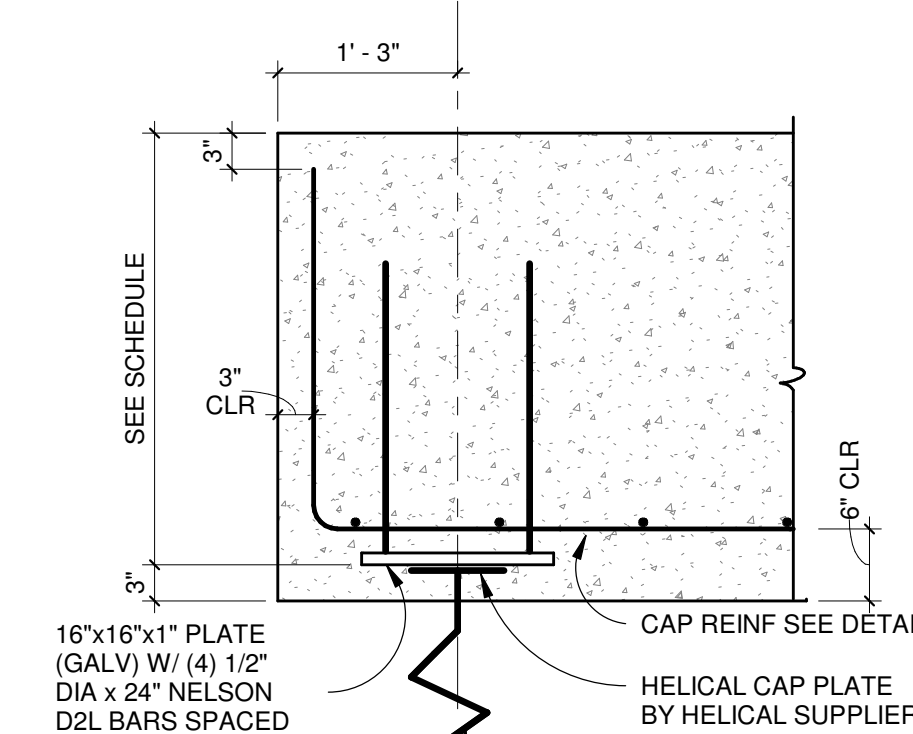
11
S201
PILE CAP PH2
SCALE: 3/4" = 1'-0"



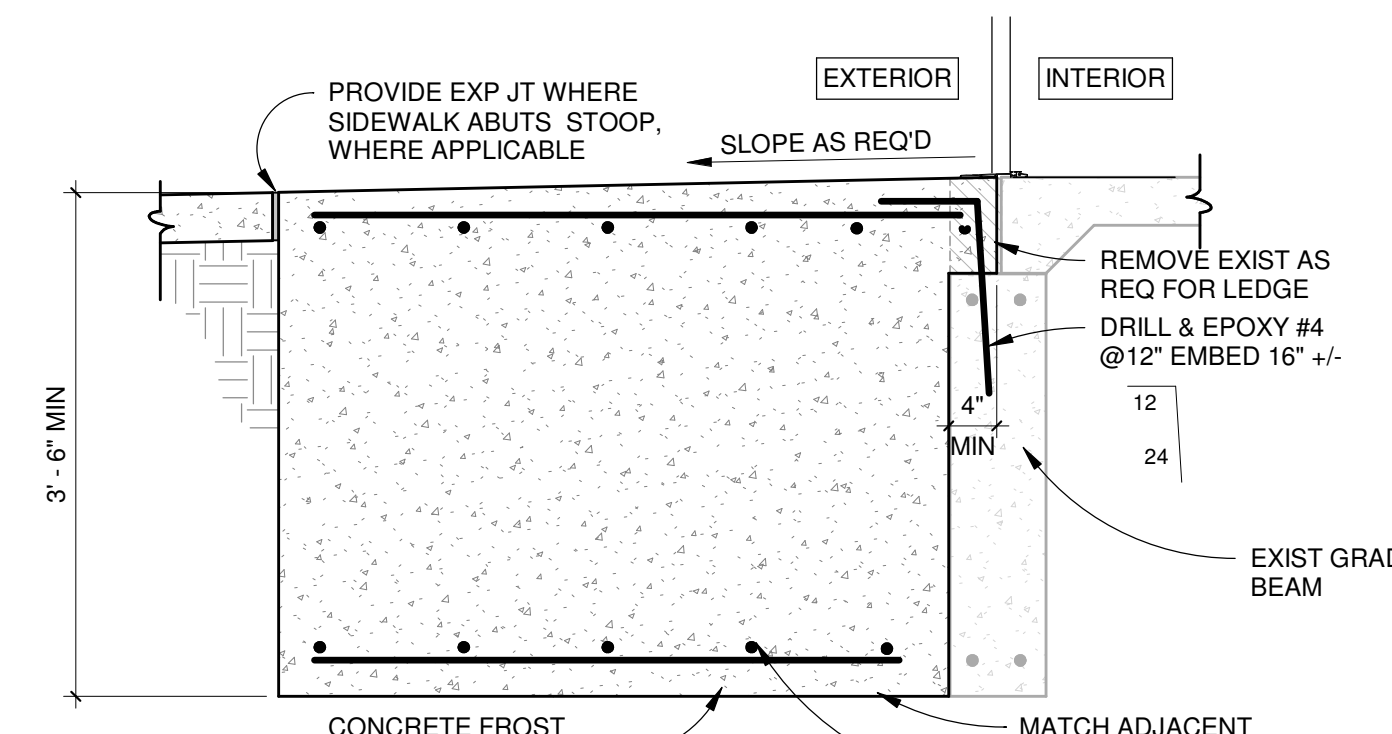
12
S201
PILE CAP PH3
SCALE: 3/4" = 1'-0"



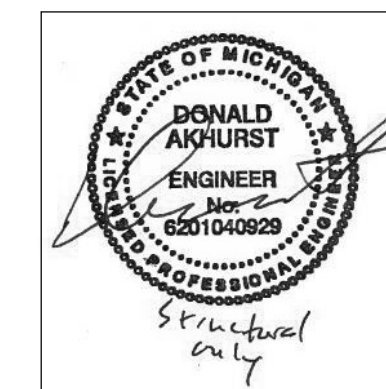
13
S201
TYPICAL RETAINING WALL
SCALE: 3/4" = 1'-0"

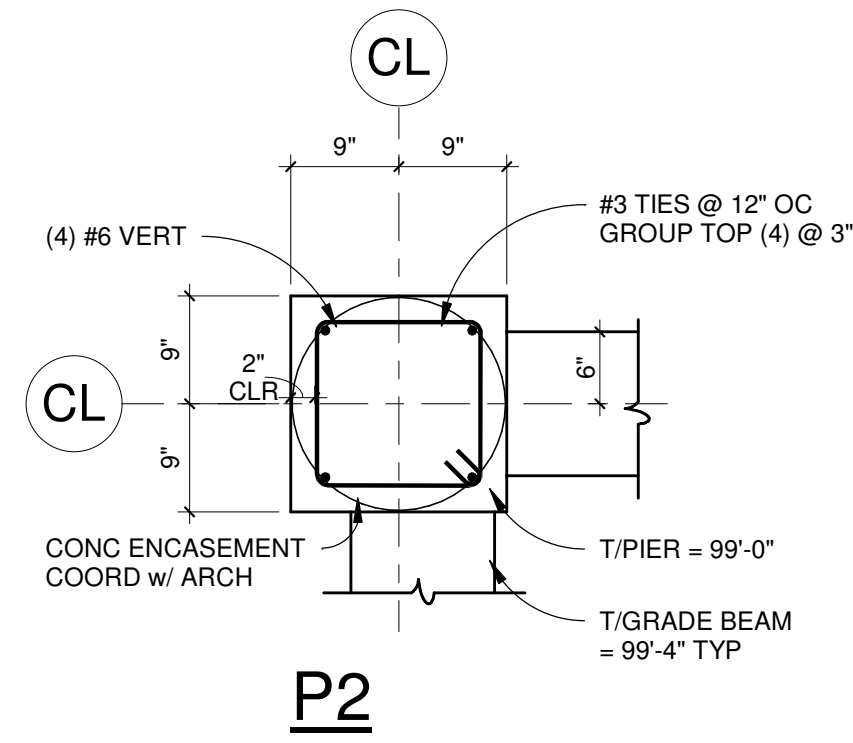
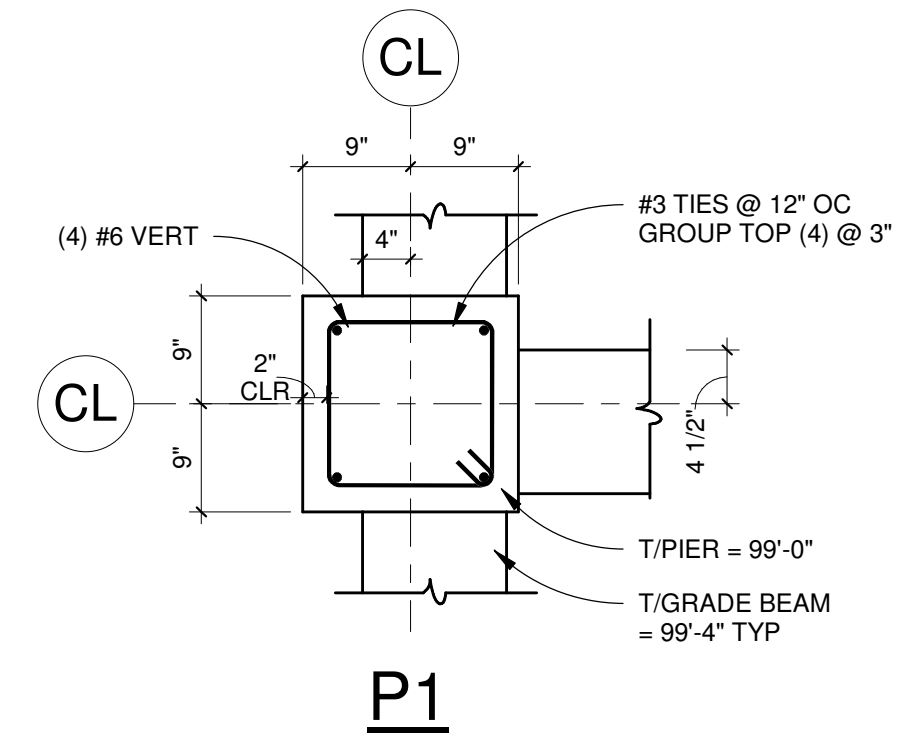
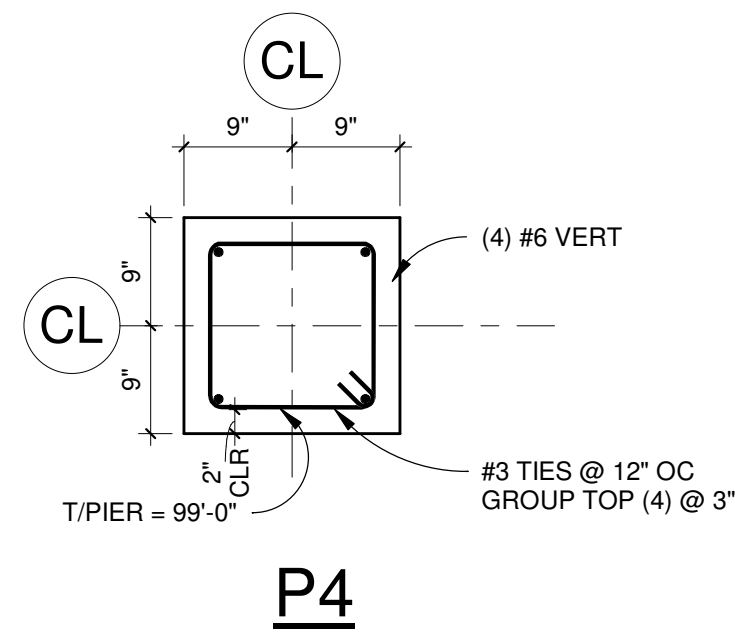
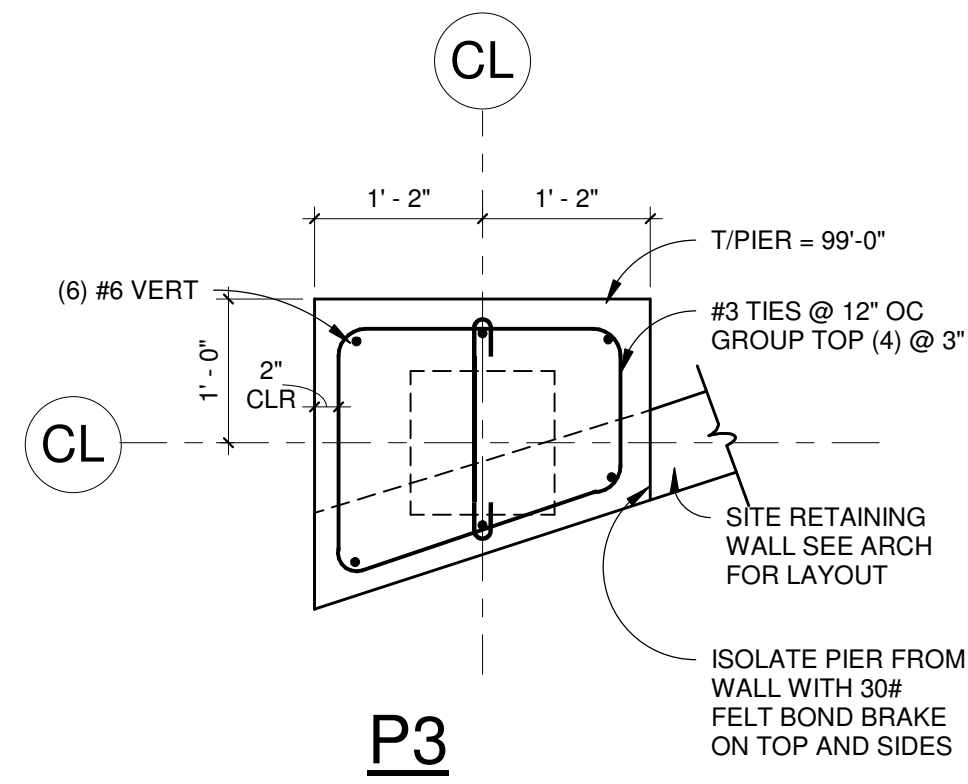


14
S201
PIER WELD PLATE DETAIL
SCALE: 3/4" = 1'-0"



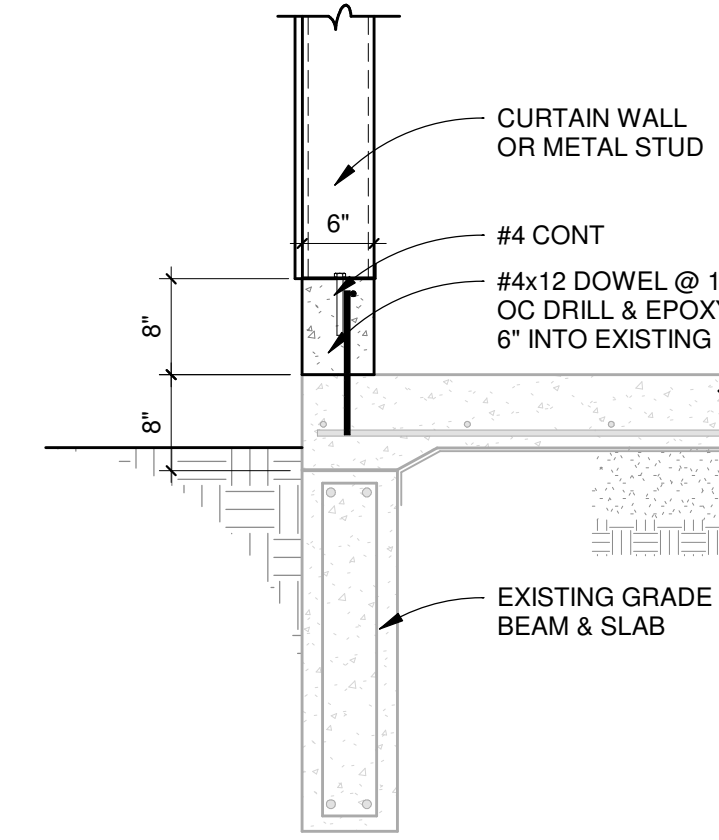
15
S201
FROST PROTECTED DOOR THRESHOLD DETAIL
SCALE: 3/4" = 1'-0"





PIER DETAIL NOTES

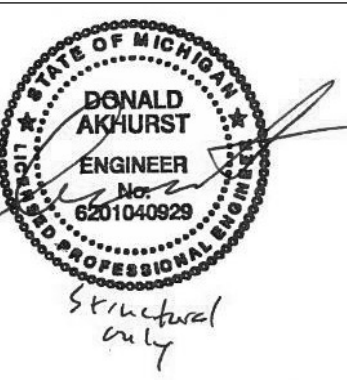
1. See foundation plan for pier orientation and foundation plan and/or notes for pier elevation.
2. Provide dowels from footing equal in size and number to vertical pier reinforcing. Hook dowels in footing and extend into pier by a distance equal to lap splice length or to top of pier (TOP).
3. Where pier is integral with foundation wall, see foundation plan and foundation details for foundation wall condition, top of concrete (TOC) elevation and wall reinforcing at adjacent foundation wall. Continue all horz wall reinf thru piers.
4. Where pier is integral with foundation wall and where required, pour concrete at wall above top of pier elevation to top of wall (TOW) elevation of adjacent wall after column is set & base plate is grouted.
5. Coat all base plates and anchor bolts with bituminous material where exposed to earth or weather, such as within a veneer cavity.
6. Chamfer all edges of exposed piers 3/4" x 45°.



1
PIERS
SCALE: 3/4" = 1'-0"

2
CURB AT EXISTING CONSTRUCTION
SCALE: 3/4" = 1'-0"

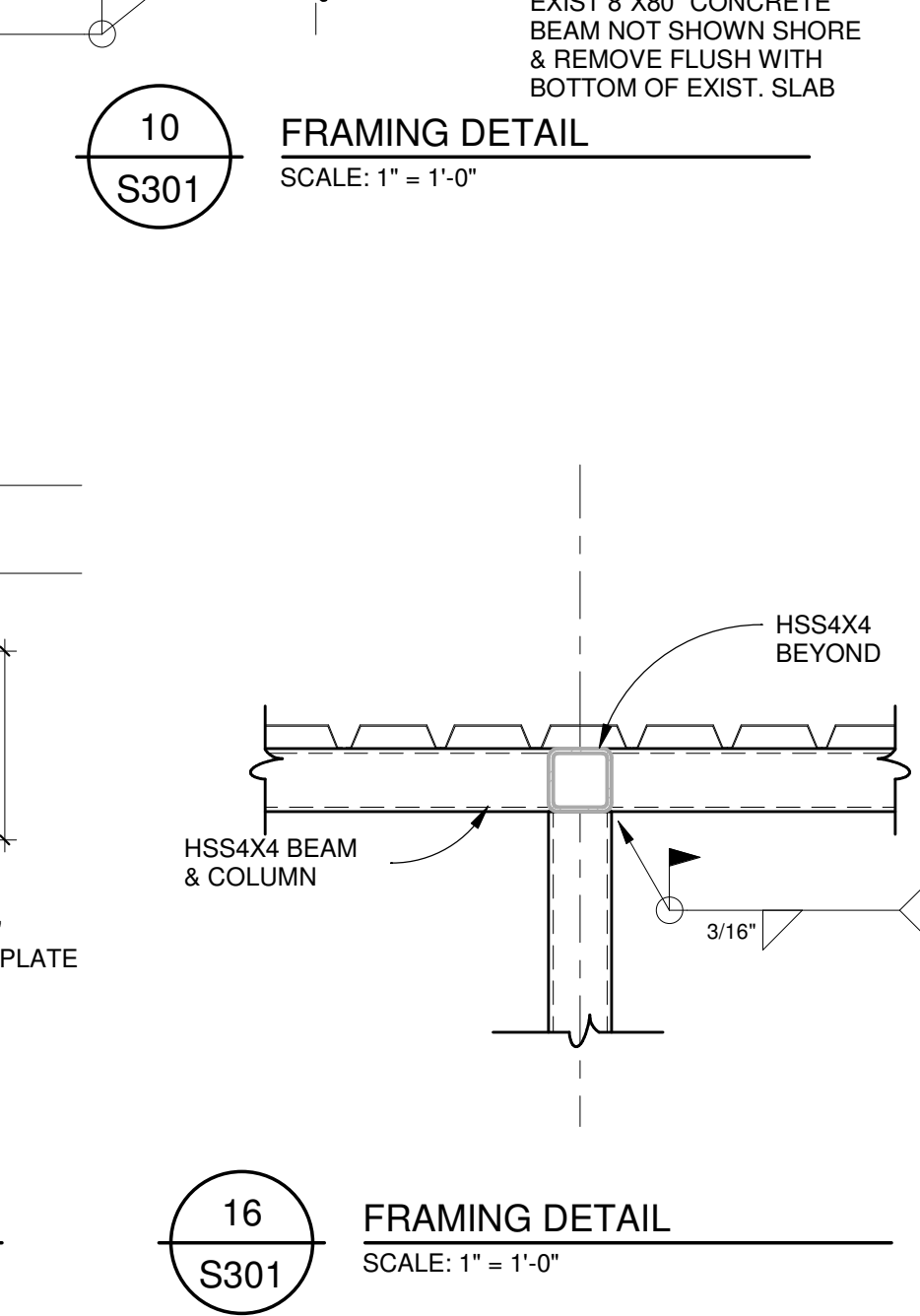
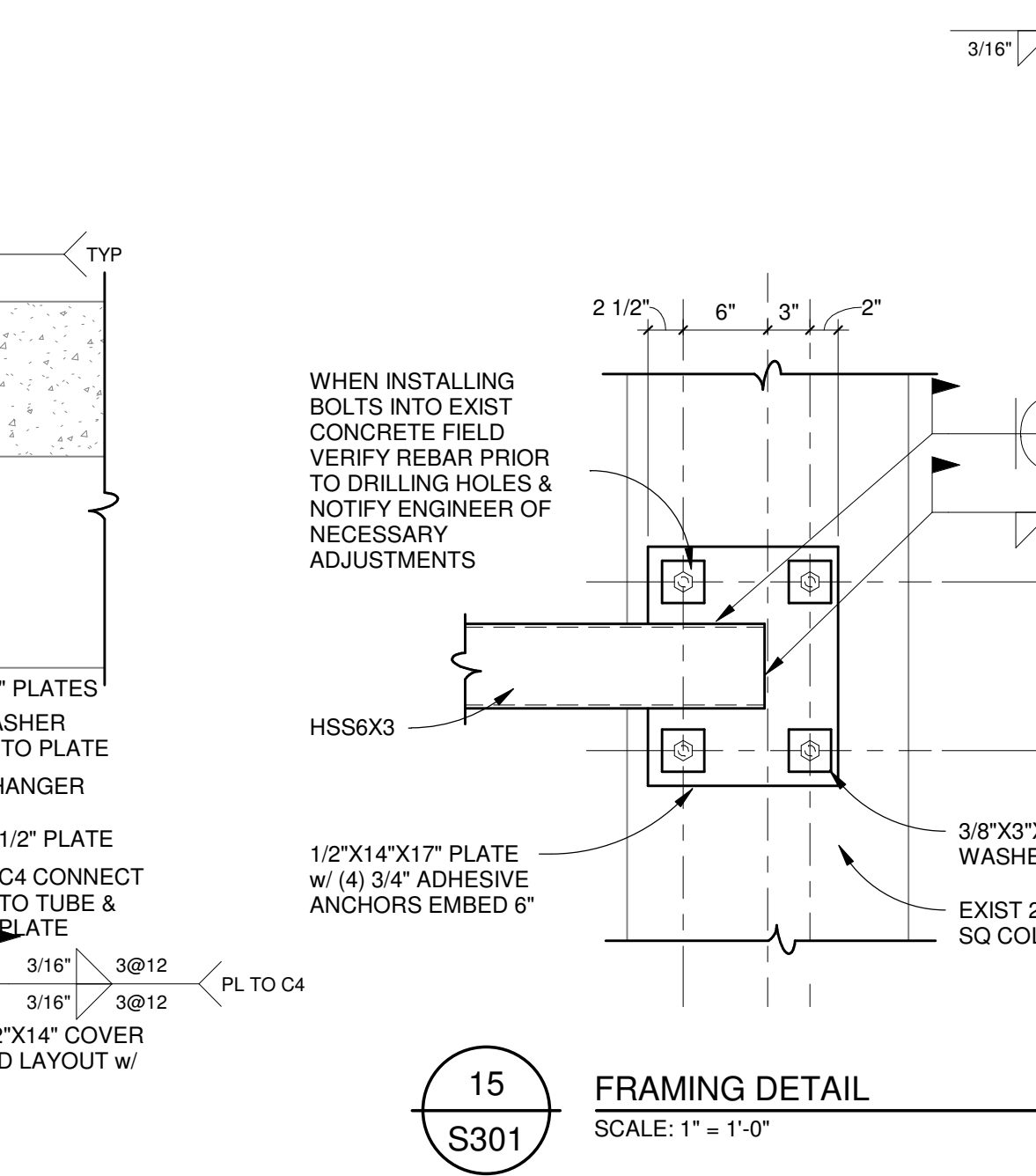
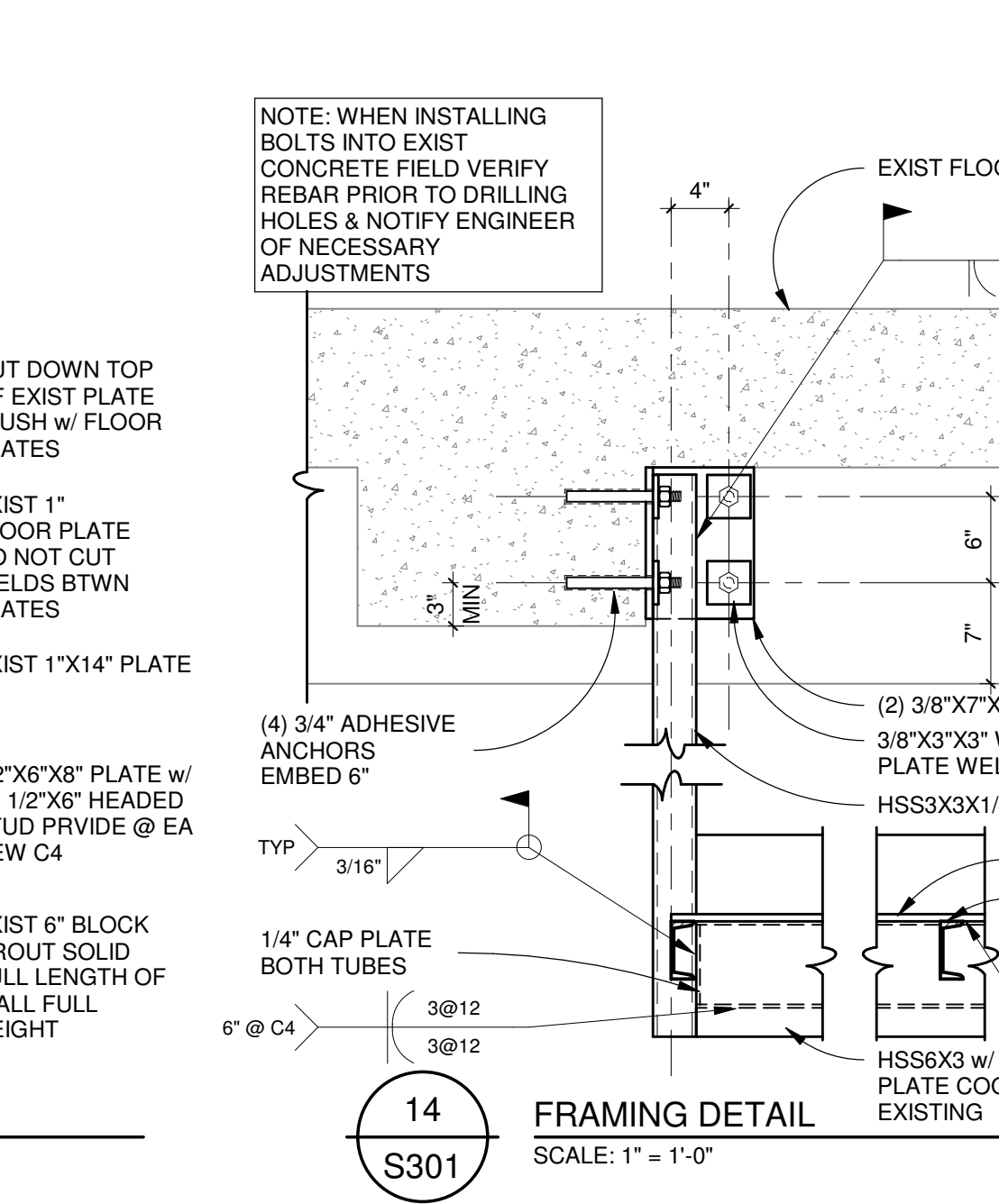
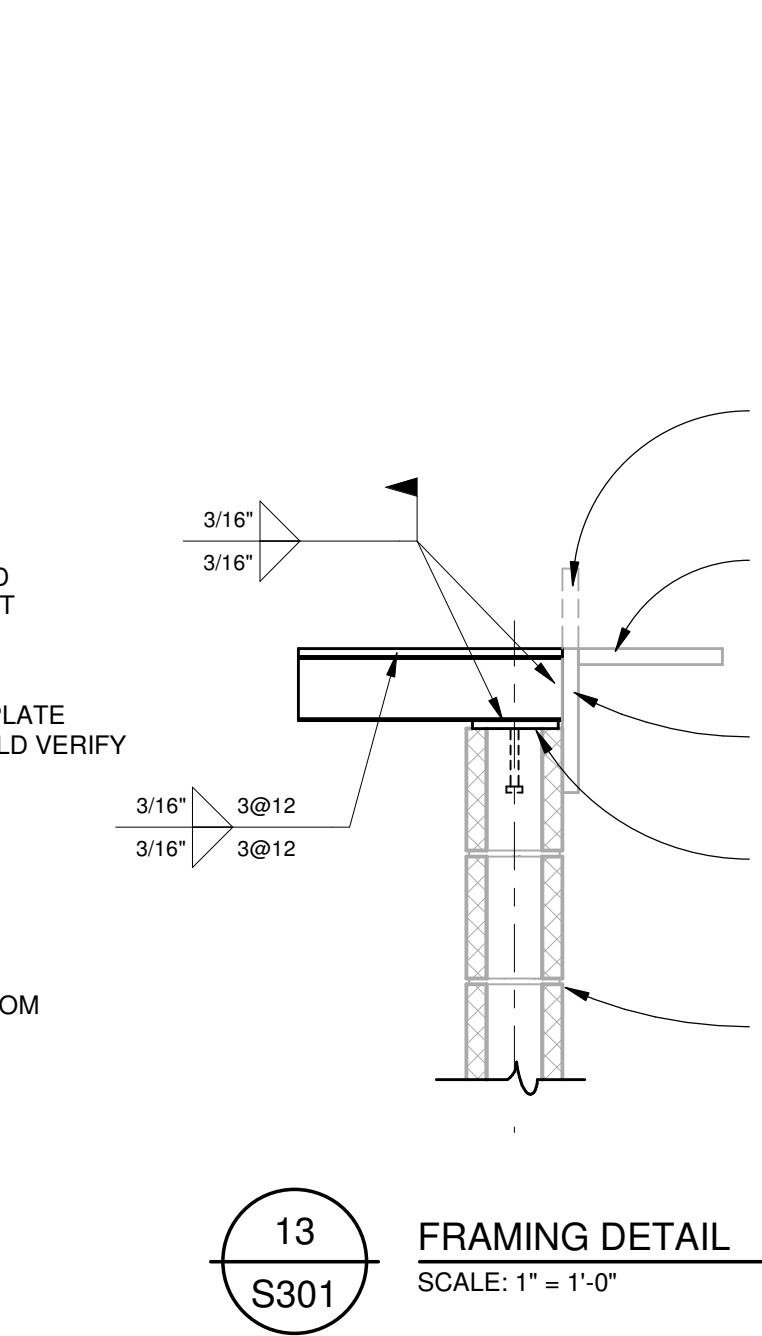
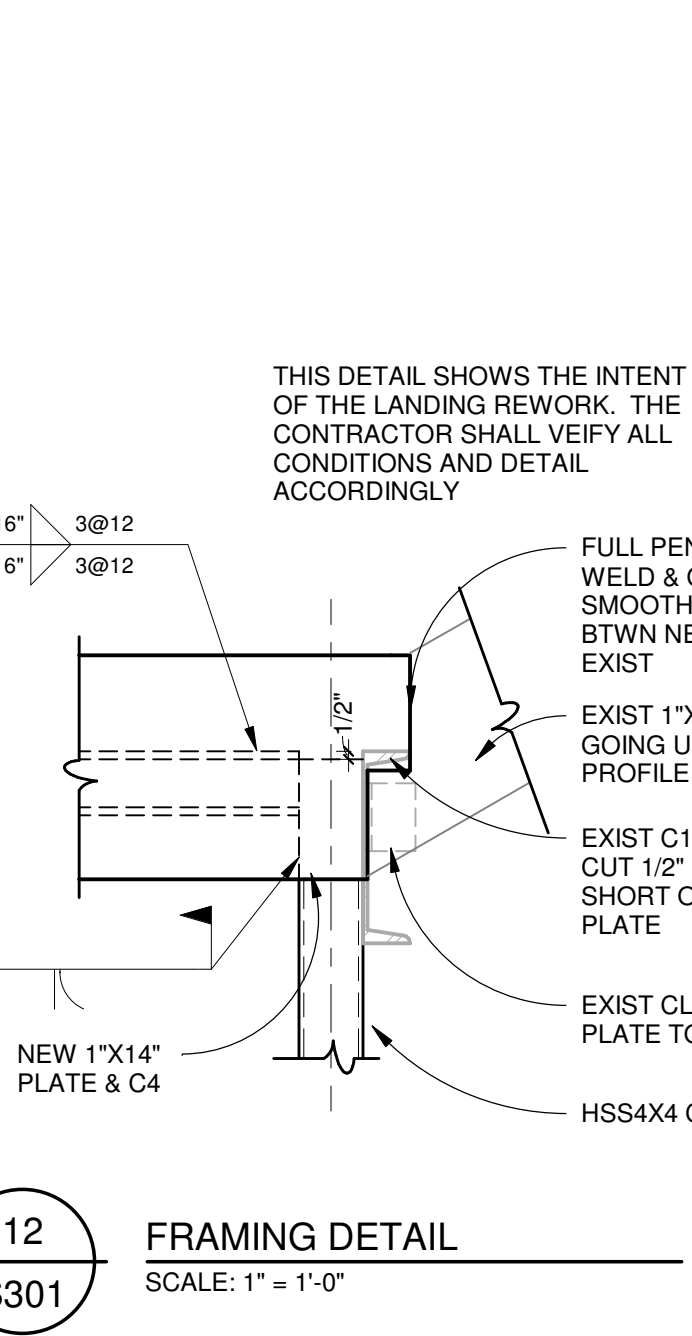
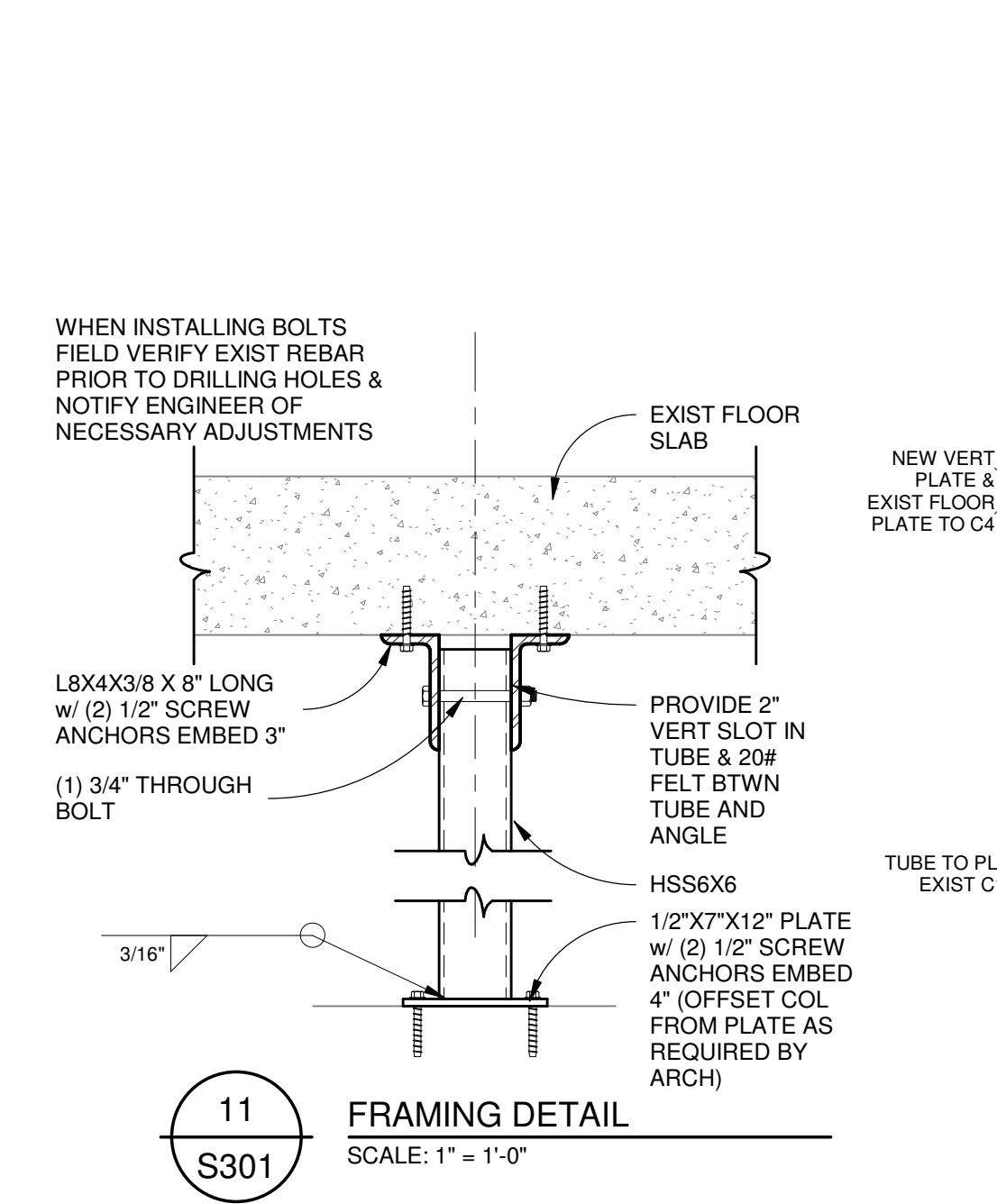
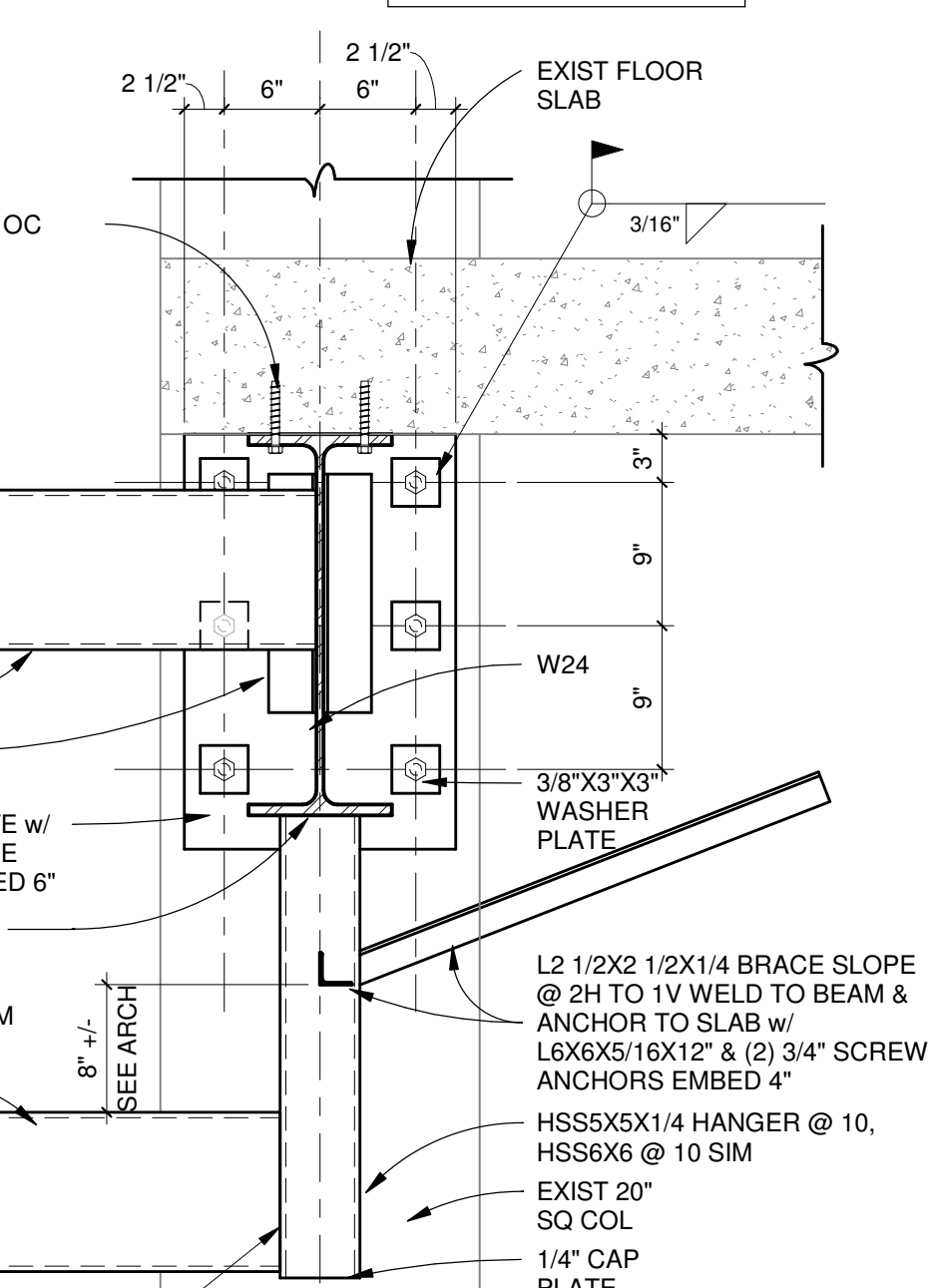
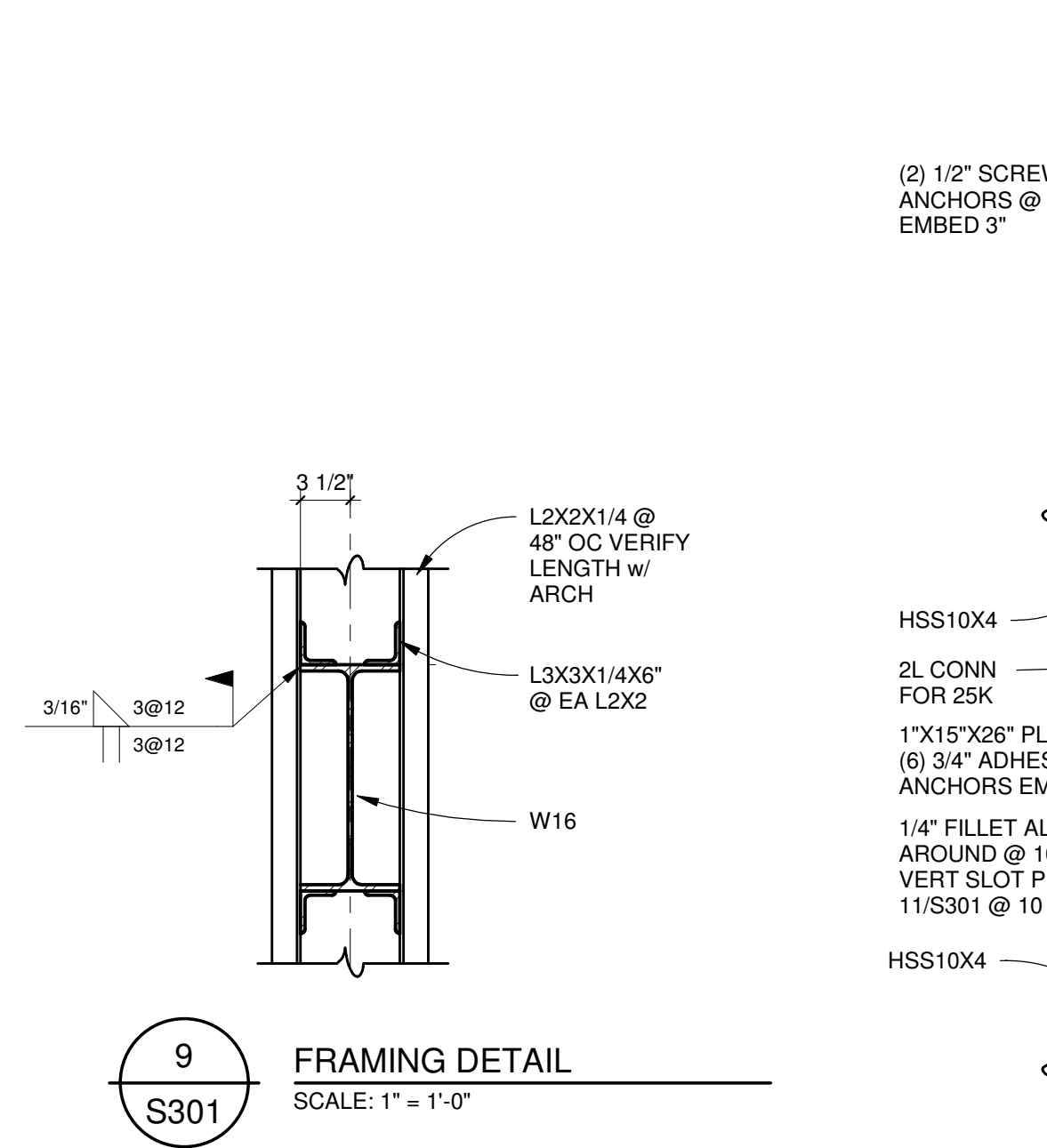
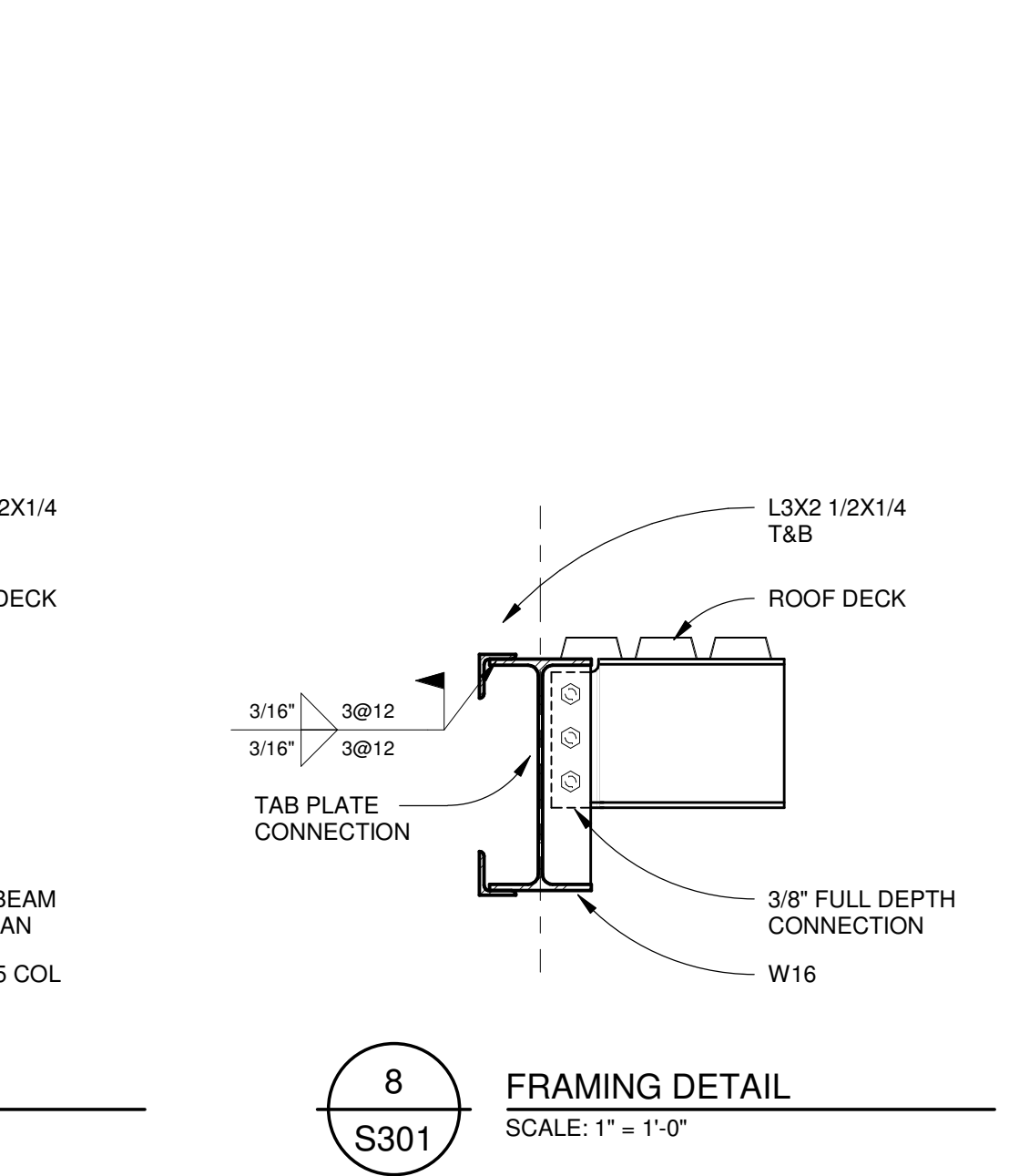
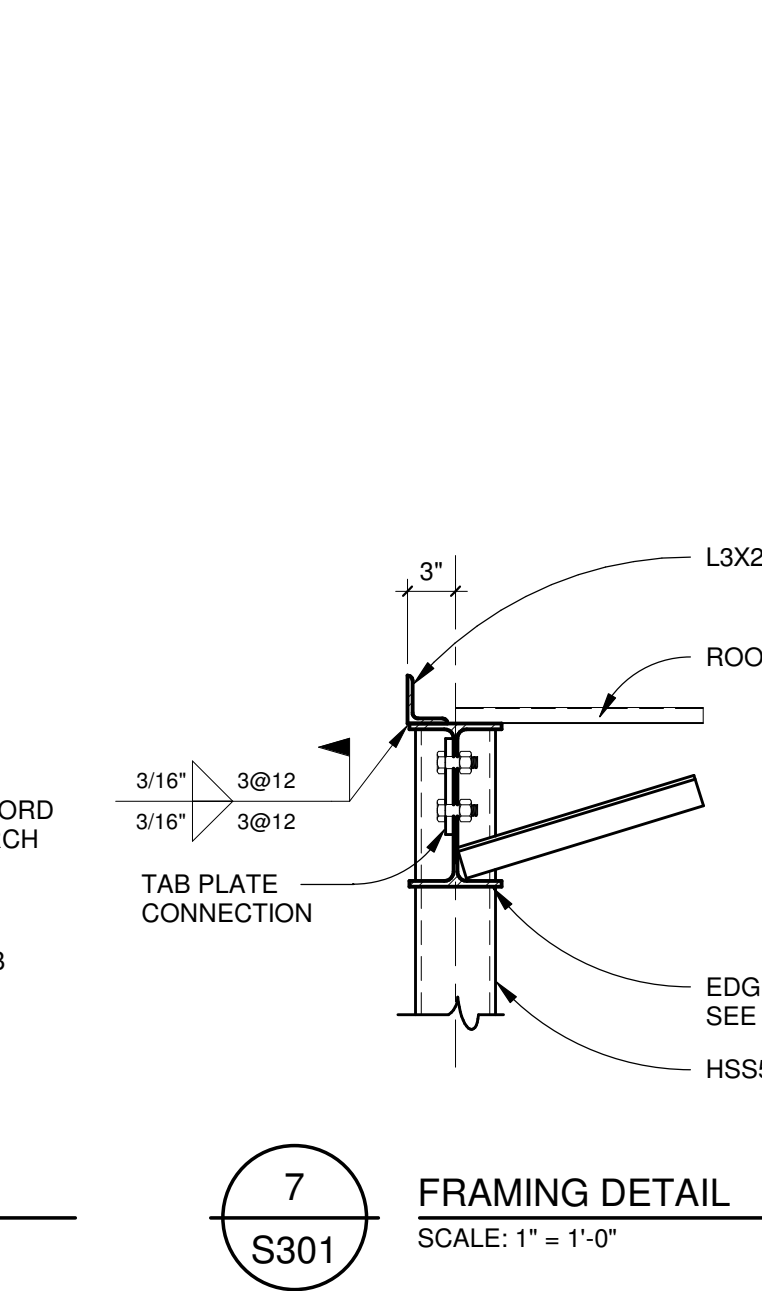
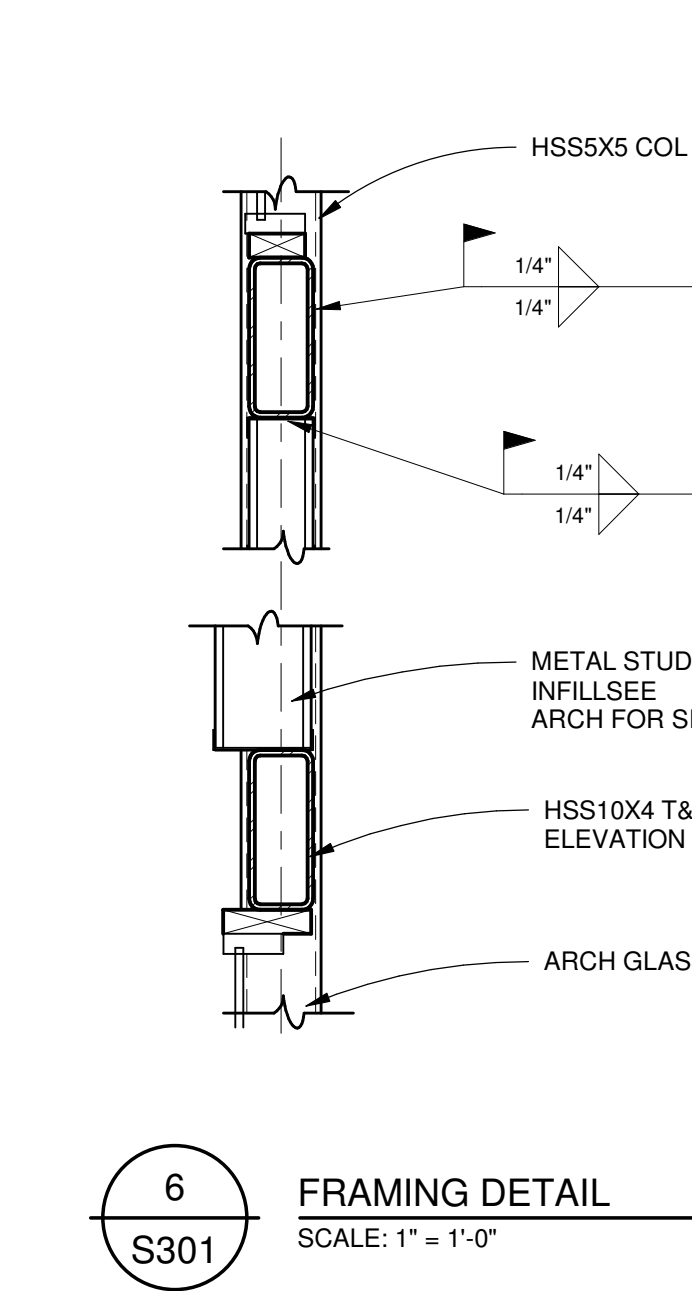
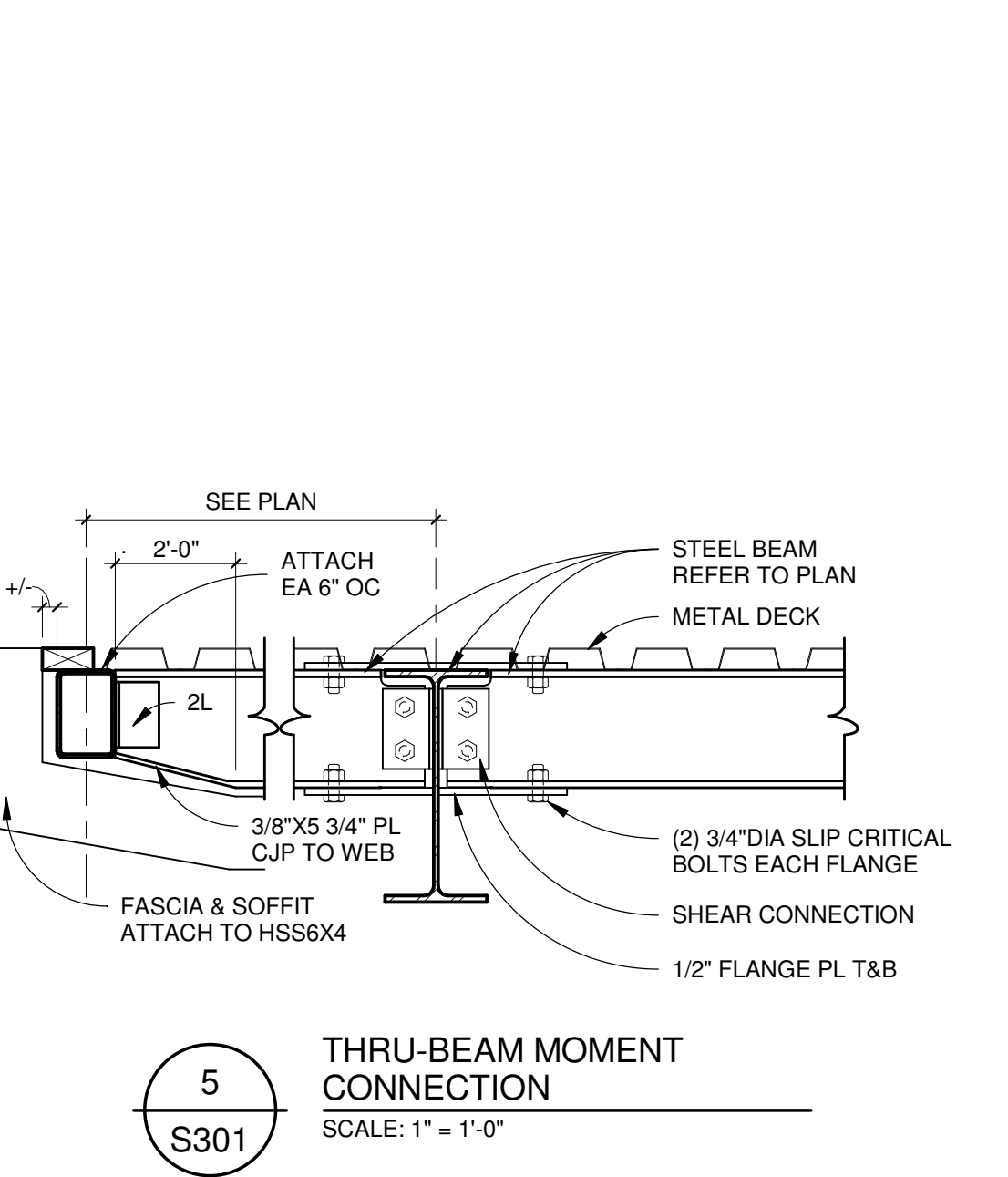
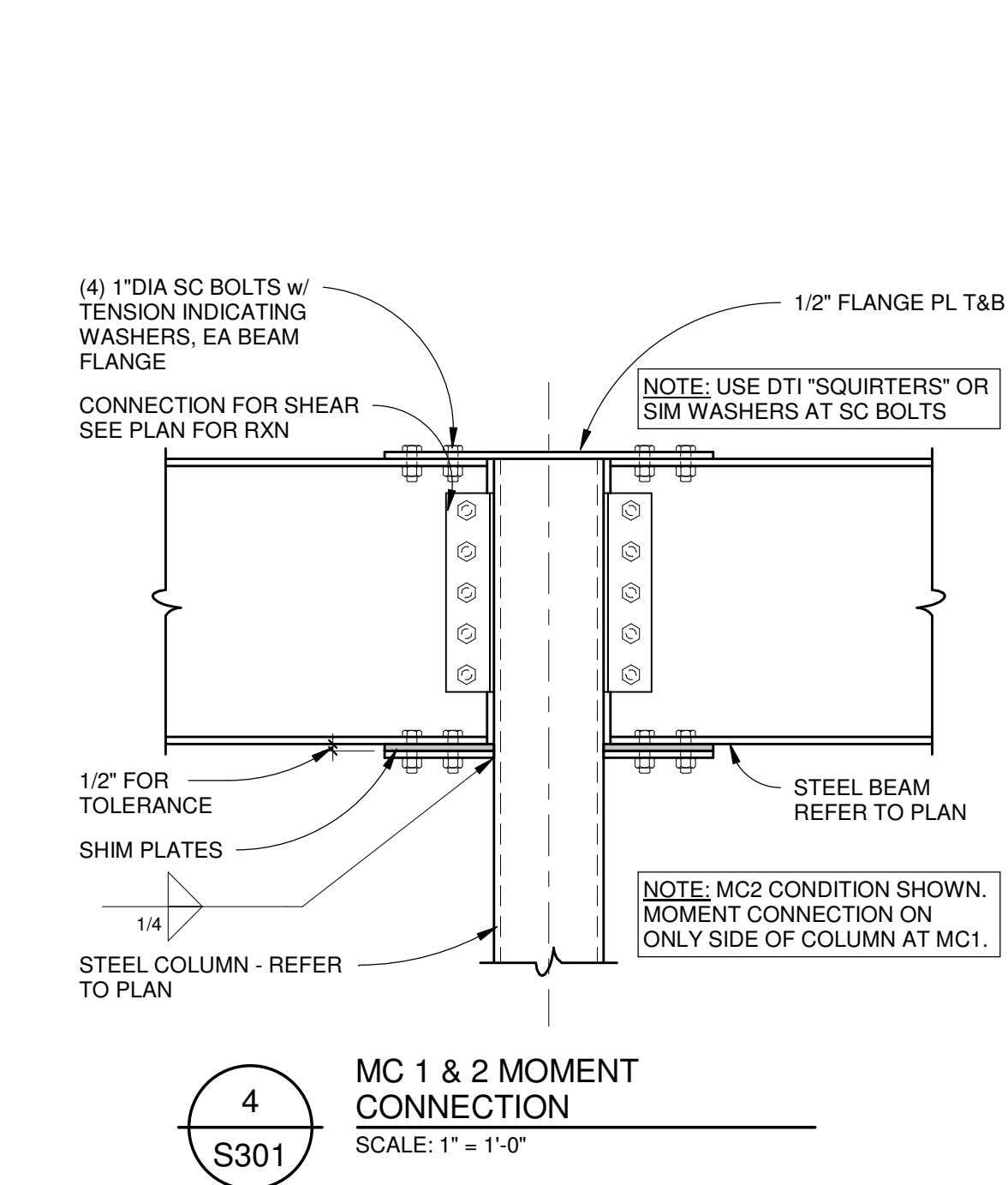
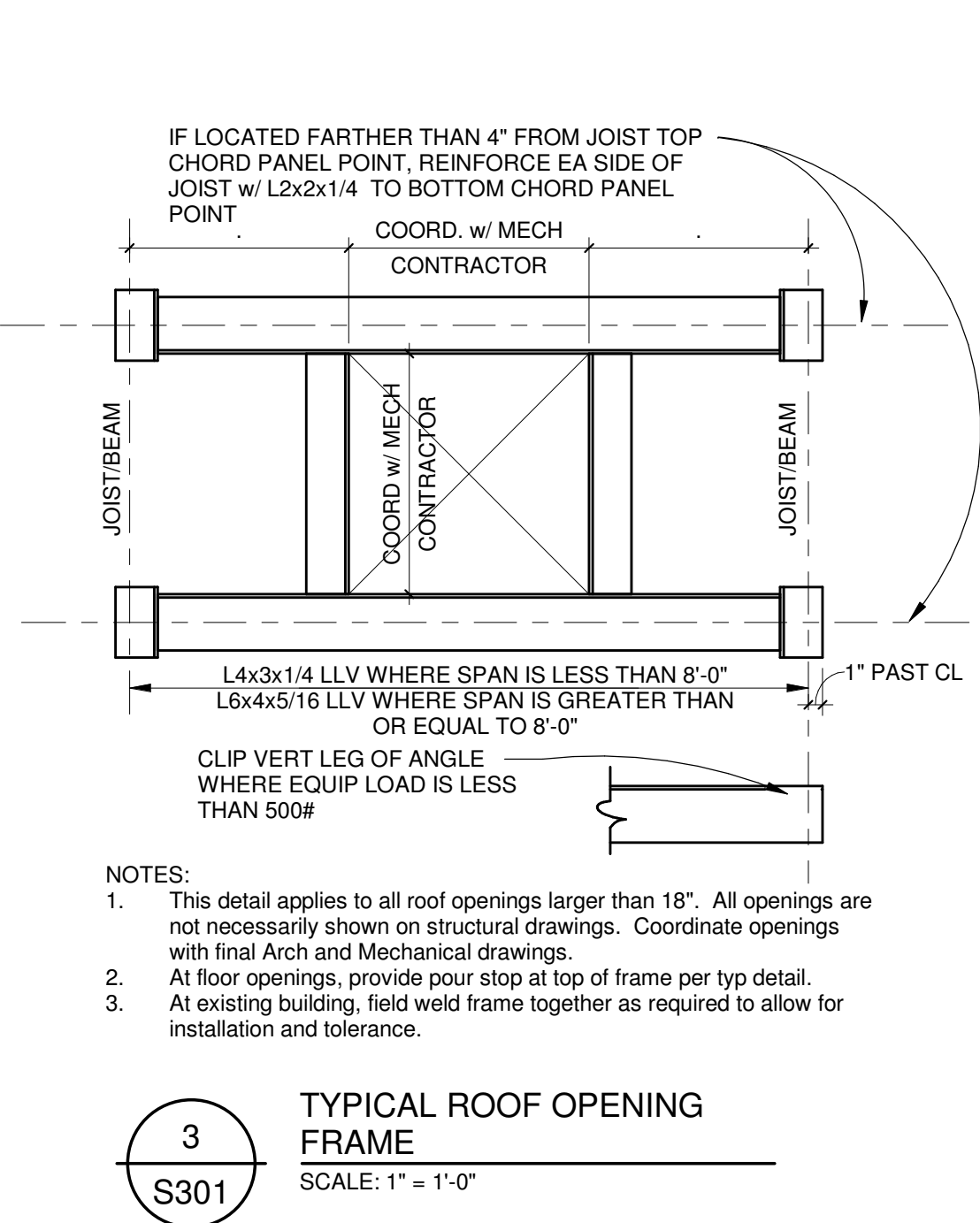
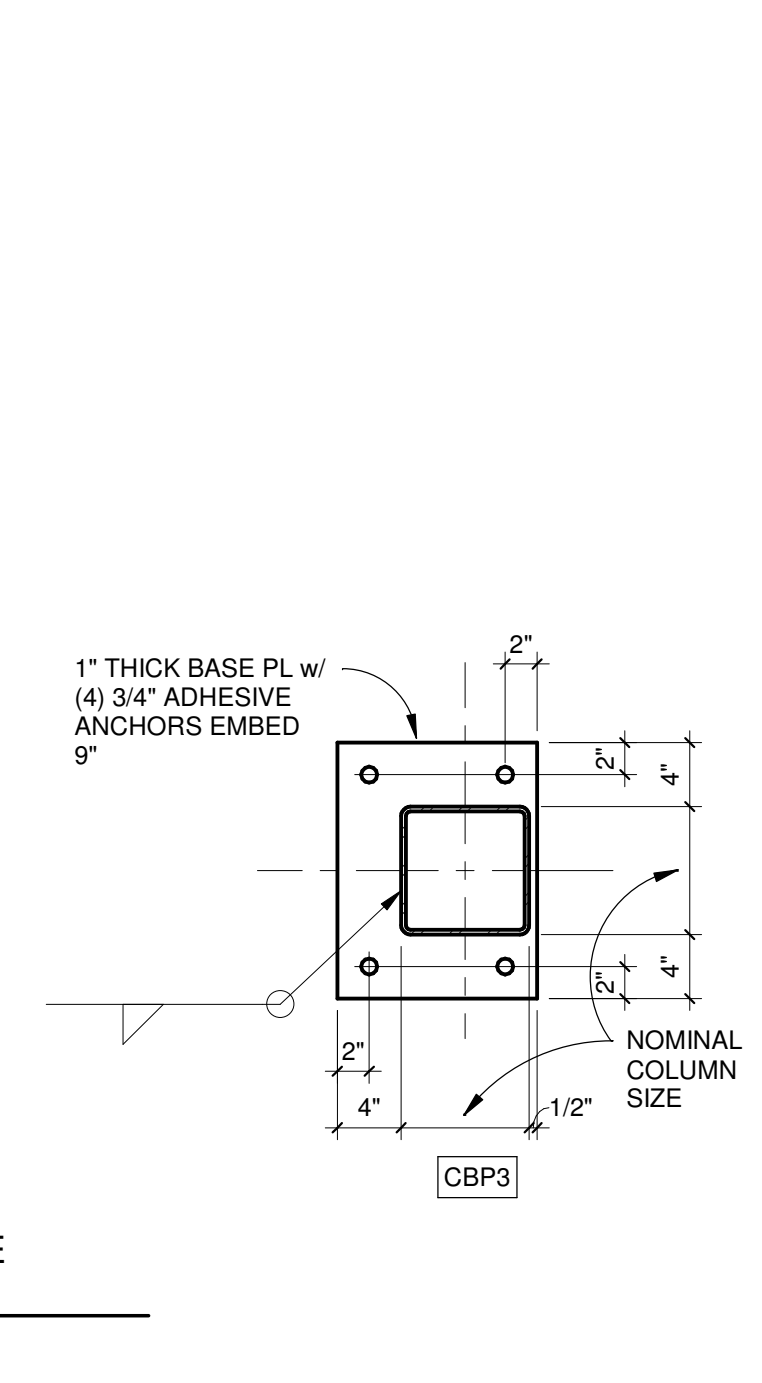
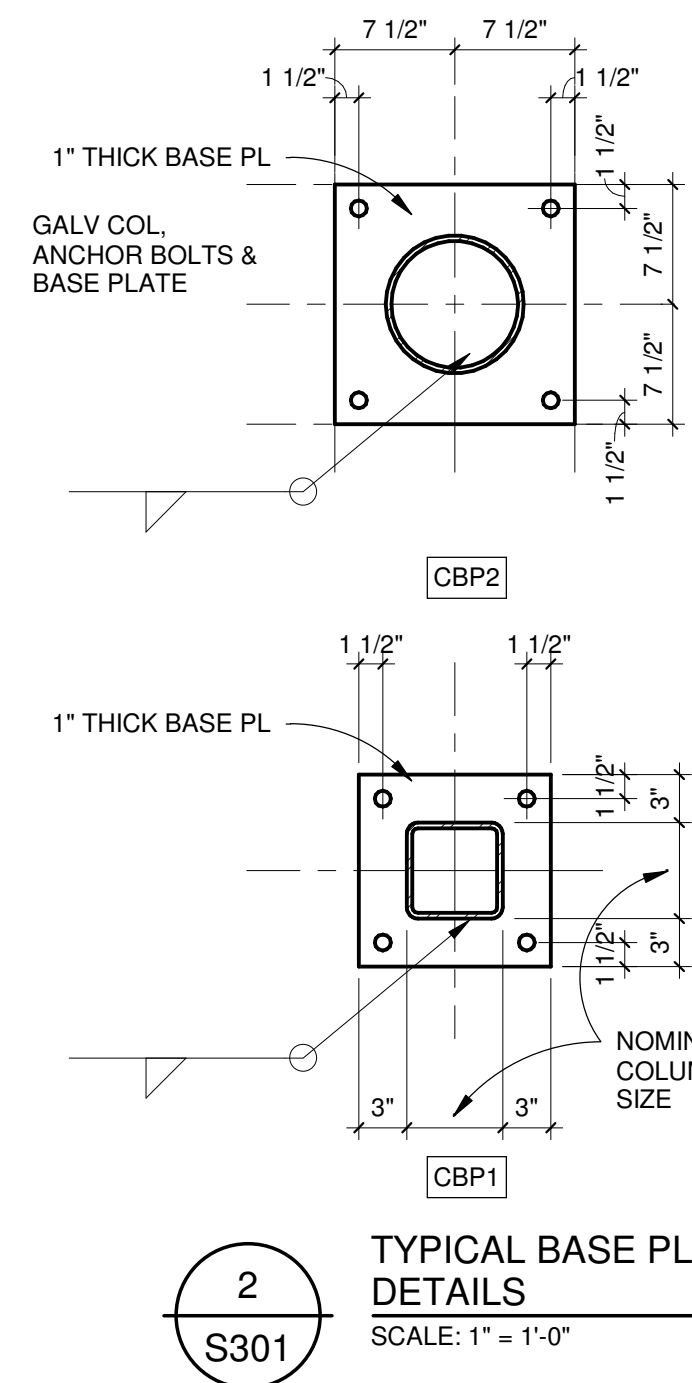
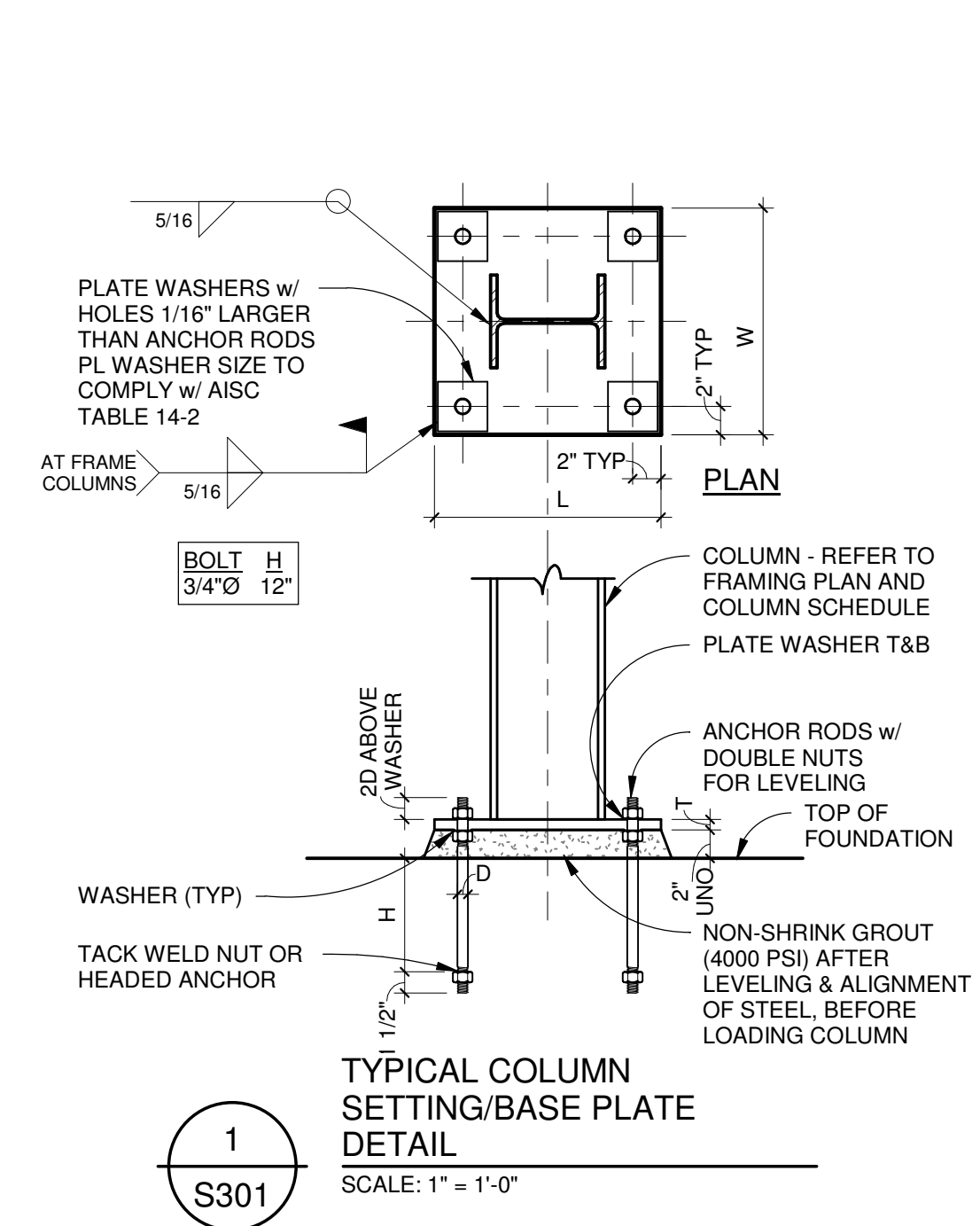
City of Kalamazoo - Crosstown Facility
CPED & KDPS Workplace Renovation
150 E Crosstown Parkway Kalamazoo MI 49001



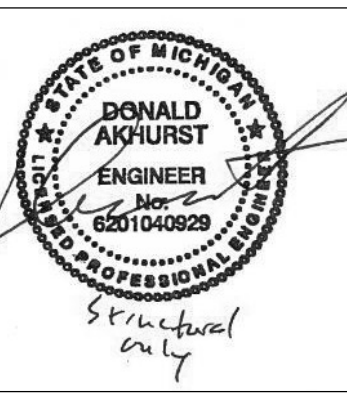
Bid Set 08/21/2025
ISSUE DATES
© 2024, intersect studio, llc
Project Number: 23-046

FOUNDATION
DETAILS

S202



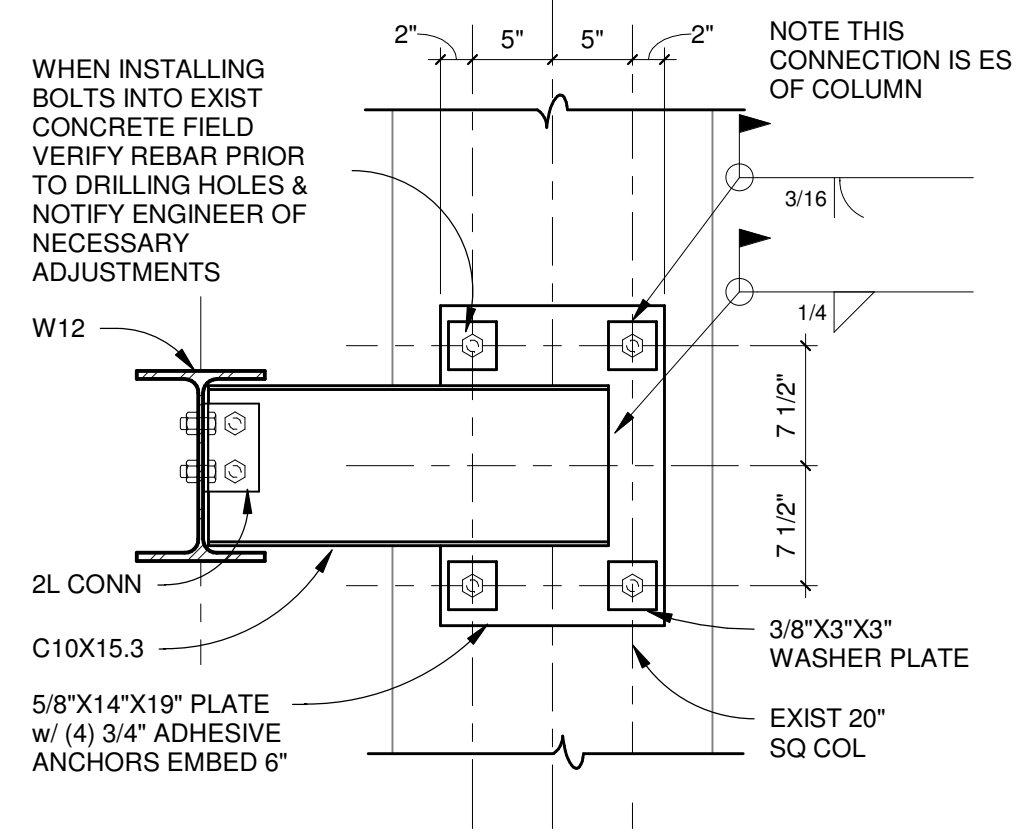
City of Kalamazoo - Crosstown Facility
CPED & KDPS Workplace Renovation
150 E Crosstown Parkway Kalamazoo MI 49001



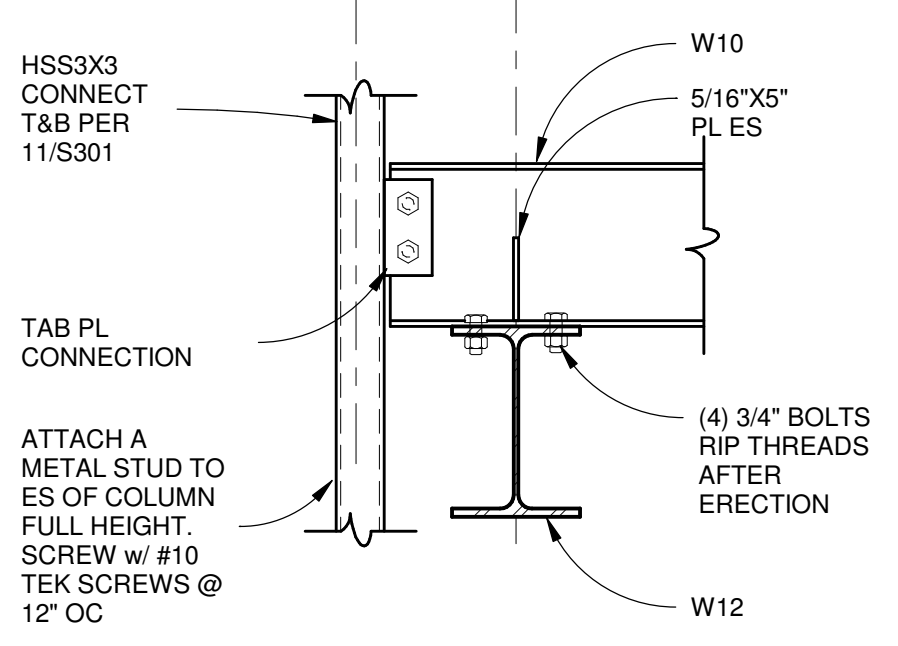
Bid Set 08/21/2025
ISSUE DATES
© 2024, intersect studio, llc
Project Number: 23-046

FRAMING DETAILS

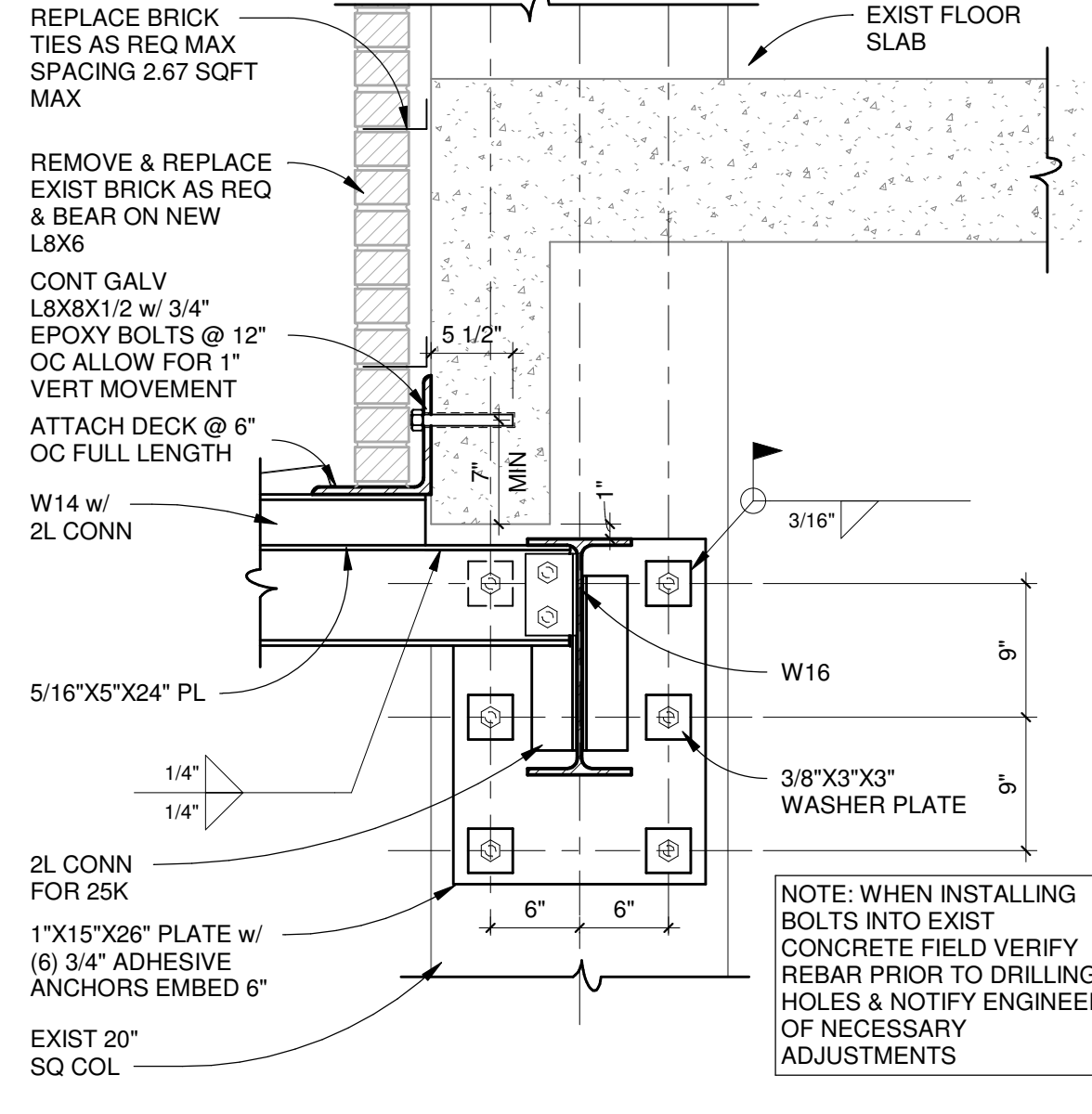
S301



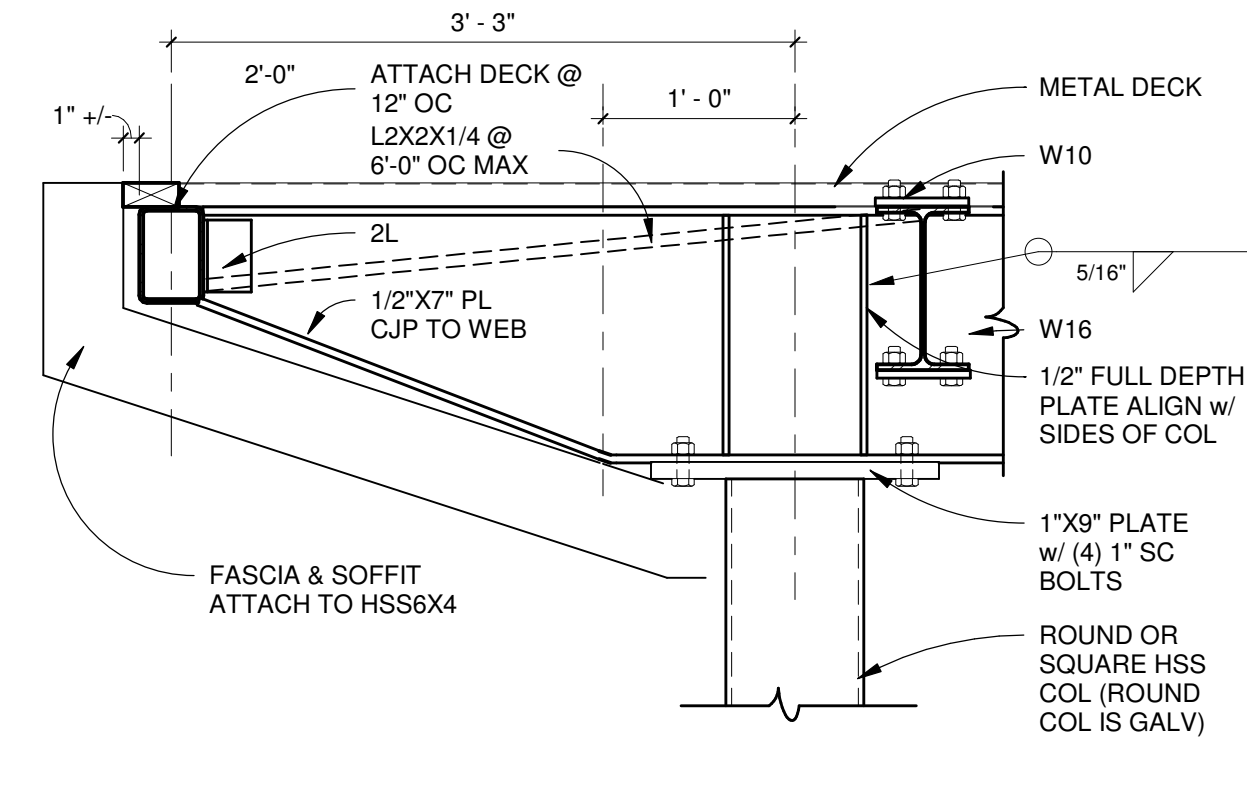
1
S302
FRAMING DETAIL
SCALE: 1" = 1'-0"



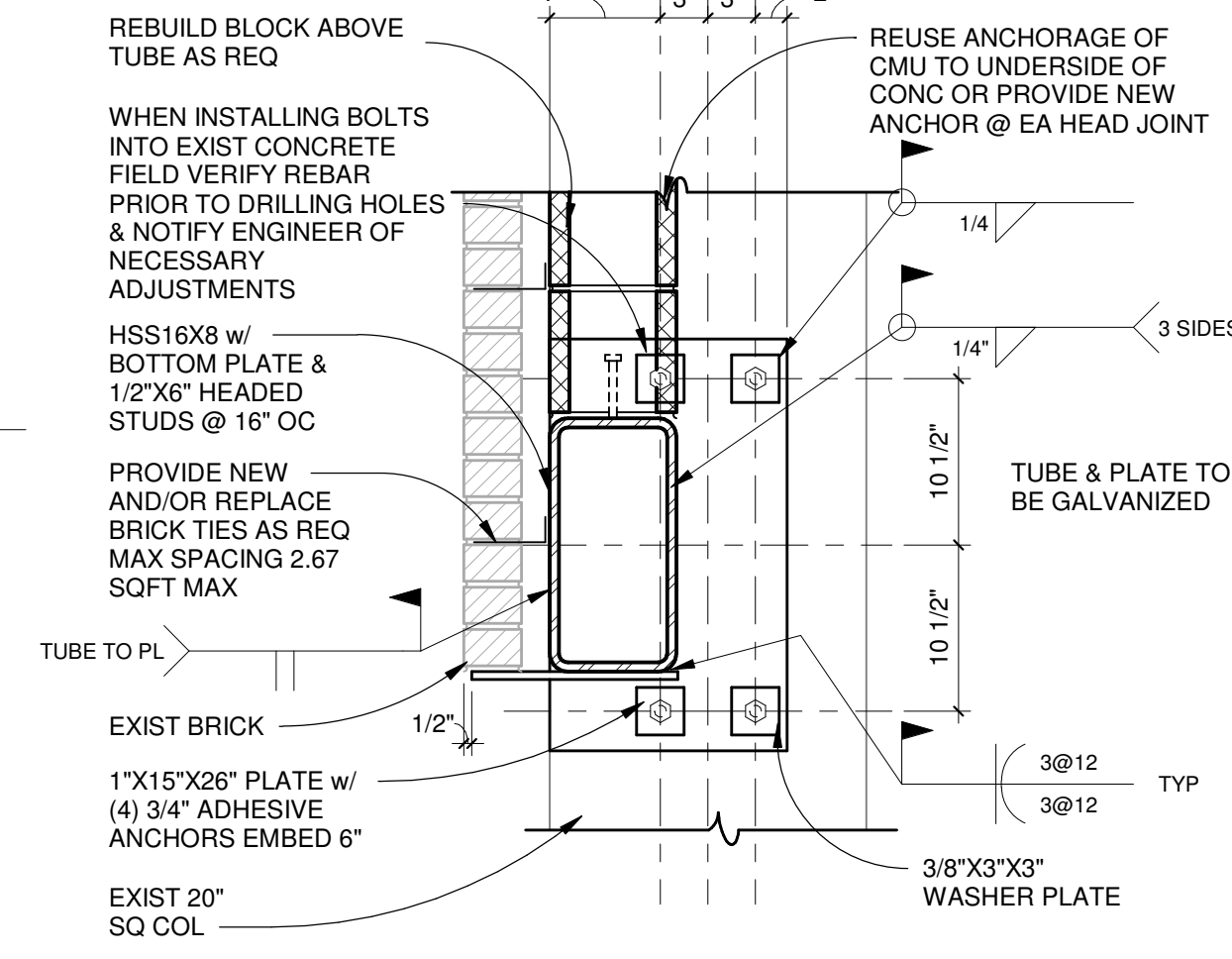
2
S302
FRAMING DETAIL
SCALE: 1" = 1'-0"



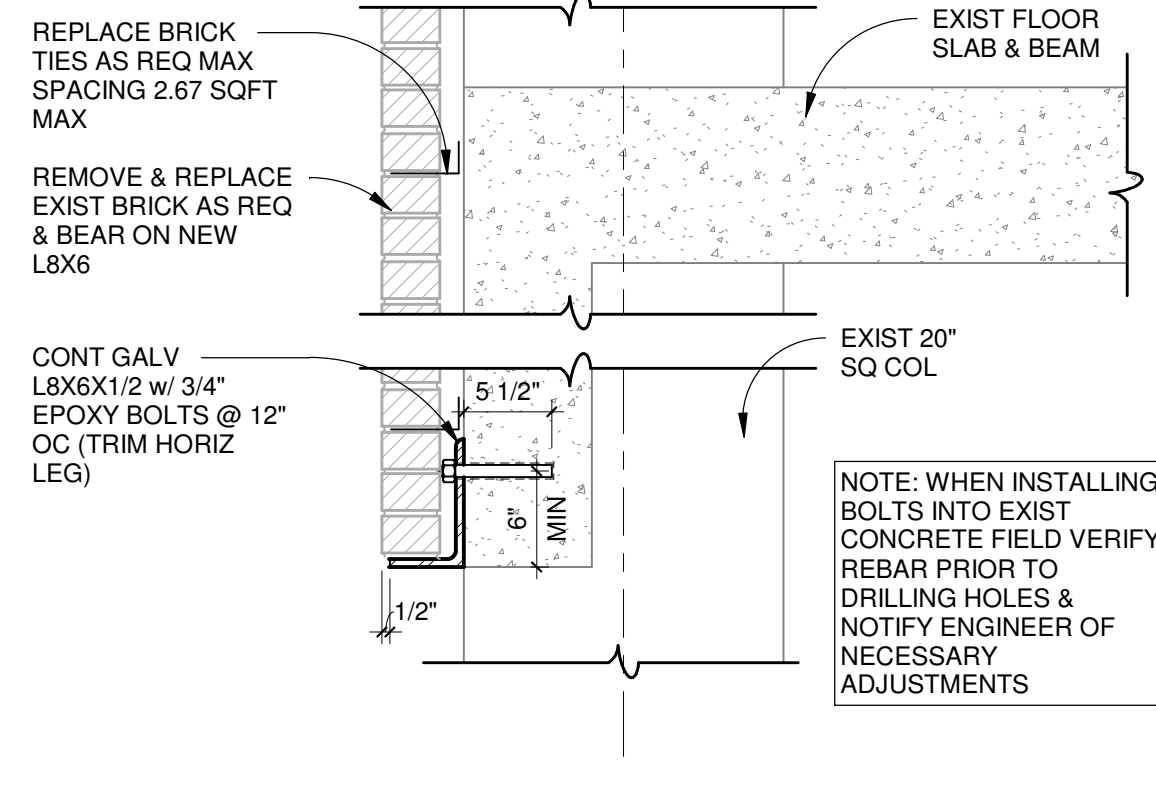
3
S302
FRAMING DETAIL
SCALE: 1" = 1'-0"



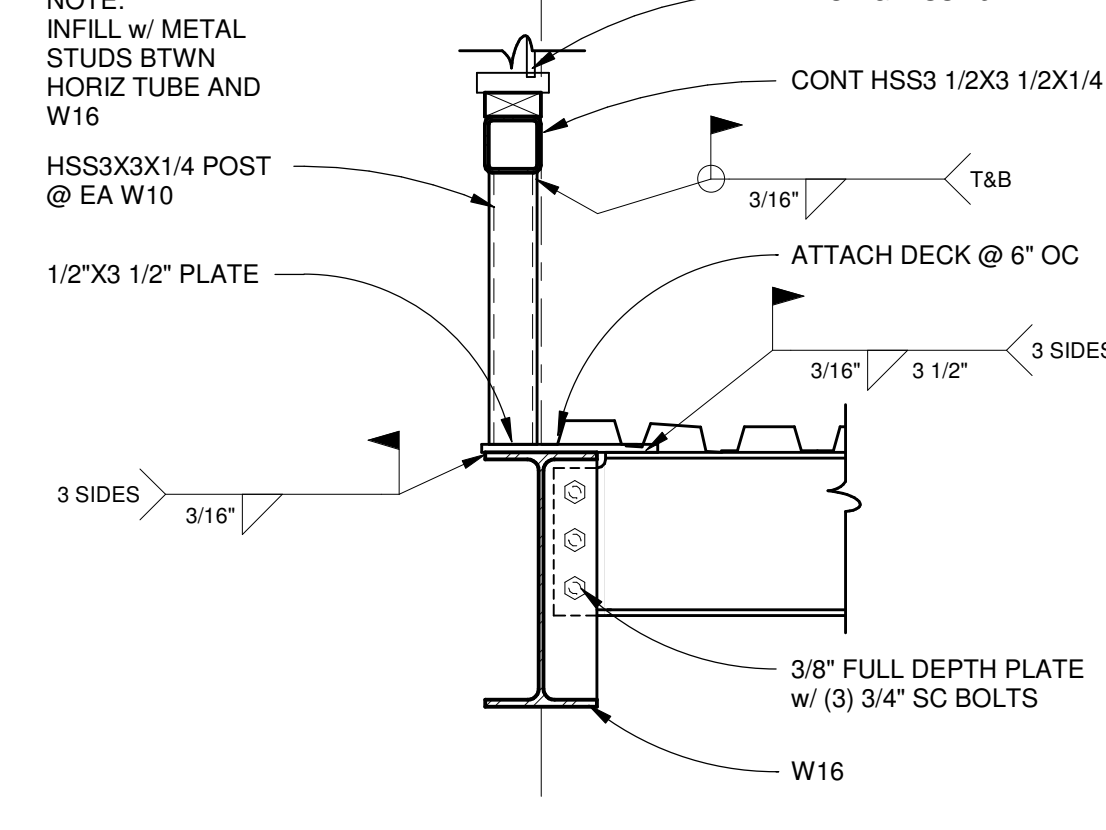
4
S302
FRAMING DETAIL
SCALE: 1" = 1'-0"



5
S302
FRAMING DETAIL
SCALE: 1" = 1'-0"

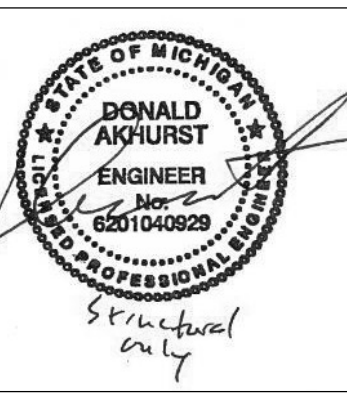


6
S302
FRAMING DETAIL
SCALE: 1" = 1'-0"

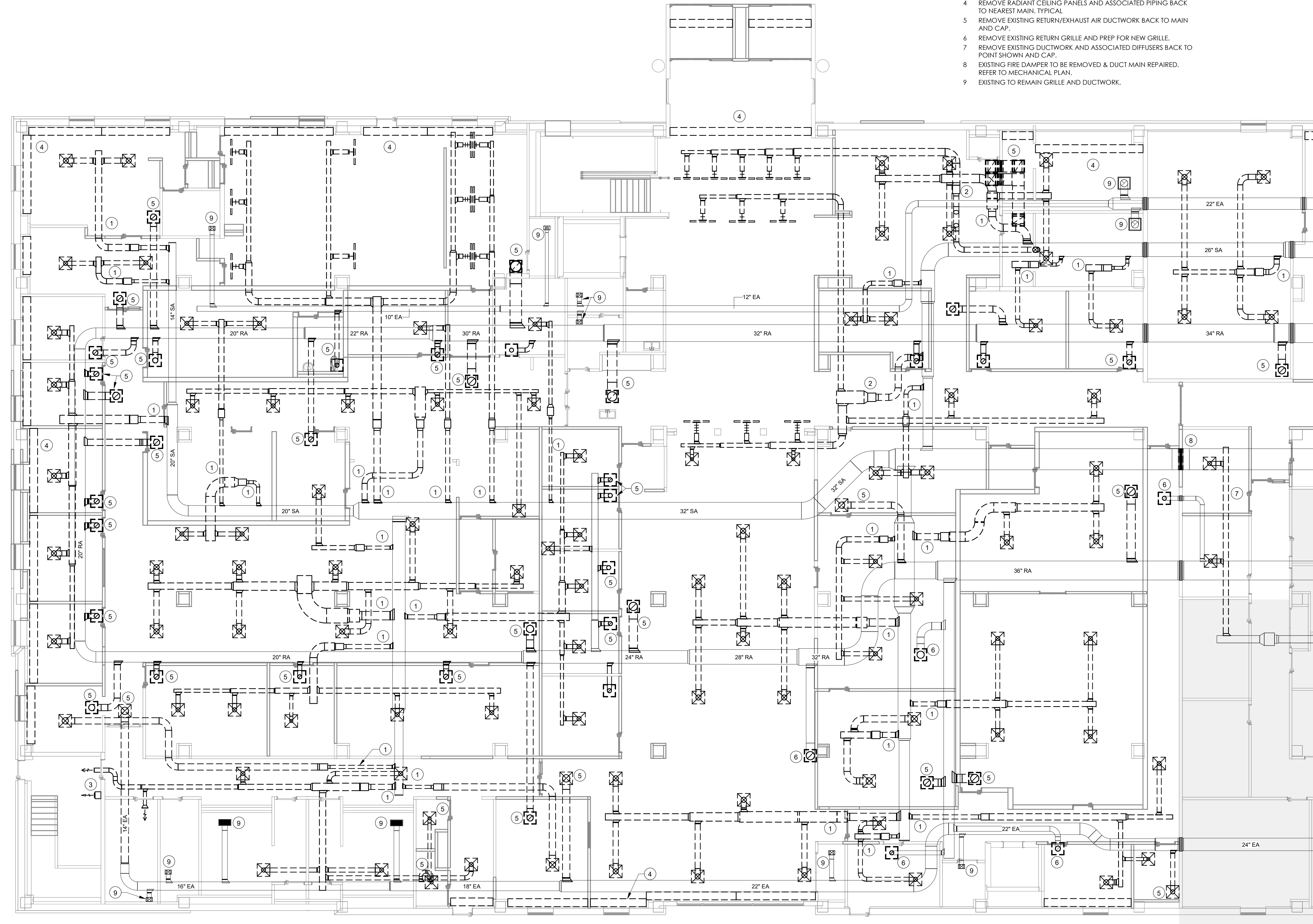


7
S302
FRAMING DETAIL
SCALE: 1" = 1'-0"

City of Kalamazoo - Crosstown Facility
CPED & KDPS Workplace Renovation
150 E Crosstown Parkway Kalamazoo MI 49001



- PLAN NOTES**
- 1 REMOVE EXISTING DUCTWORK & VAV BOX BACK TO MAIN & CAP.
 - 2 REMOVE EXISTING DUCTWORK ASSOCIATED WITH EXISTING TO REMAIN VAV BOX AND PREP VAV BOX FOR RELOCATION. REFER TO MECHANICAL PLAN.
 - 3 REMOVE EXISTING CABINET UNIT HEATER TO BE REPLACED. CAP PIPING FOR RECONNECTION.
 - 4 REMOVE EXISTING RADIANT CEILING PANELS AND ASSOCIATED PIPING BACK TO NEAREST MAIN. TYPICAL.
 - 5 REMOVE EXISTING RETURN/EXHAUST AIR DUCTWORK BACK TO MAIN AND CAP.
 - 6 REMOVE EXISTING RETURN GRILLE AND PREP FOR NEW GRILLE.
 - 7 REMOVE EXISTING DUCTWORK AND ASSOCIATED DIFFUSERS BACK TO POINT SHOWN AND CAP.
 - 8 EXISTING FIRE DAMPER TO BE REMOVED & DUCT MAIN REPAIRED. REFER TO MECHANICAL PLAN.
 - 9 EXISTING TO REMAIN GRILLE AND DUCTWORK.



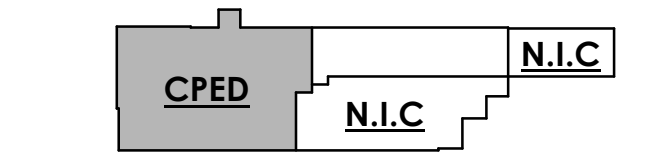
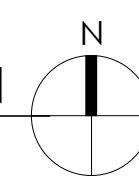
City of Kalamazoo - Crosstown Facility
 CPED & KDPS Workplace Renovation
 150 E Crosstown Parkway Kalamazoo MI 49001

NOT FOR
 REGULATORY
 APPROVAL,
 PERMITTING,
 OR
 CONSTRUCTION

Bid 08/21/2025
 © 2025, intersect studio, llc
 Project Number: 23-046

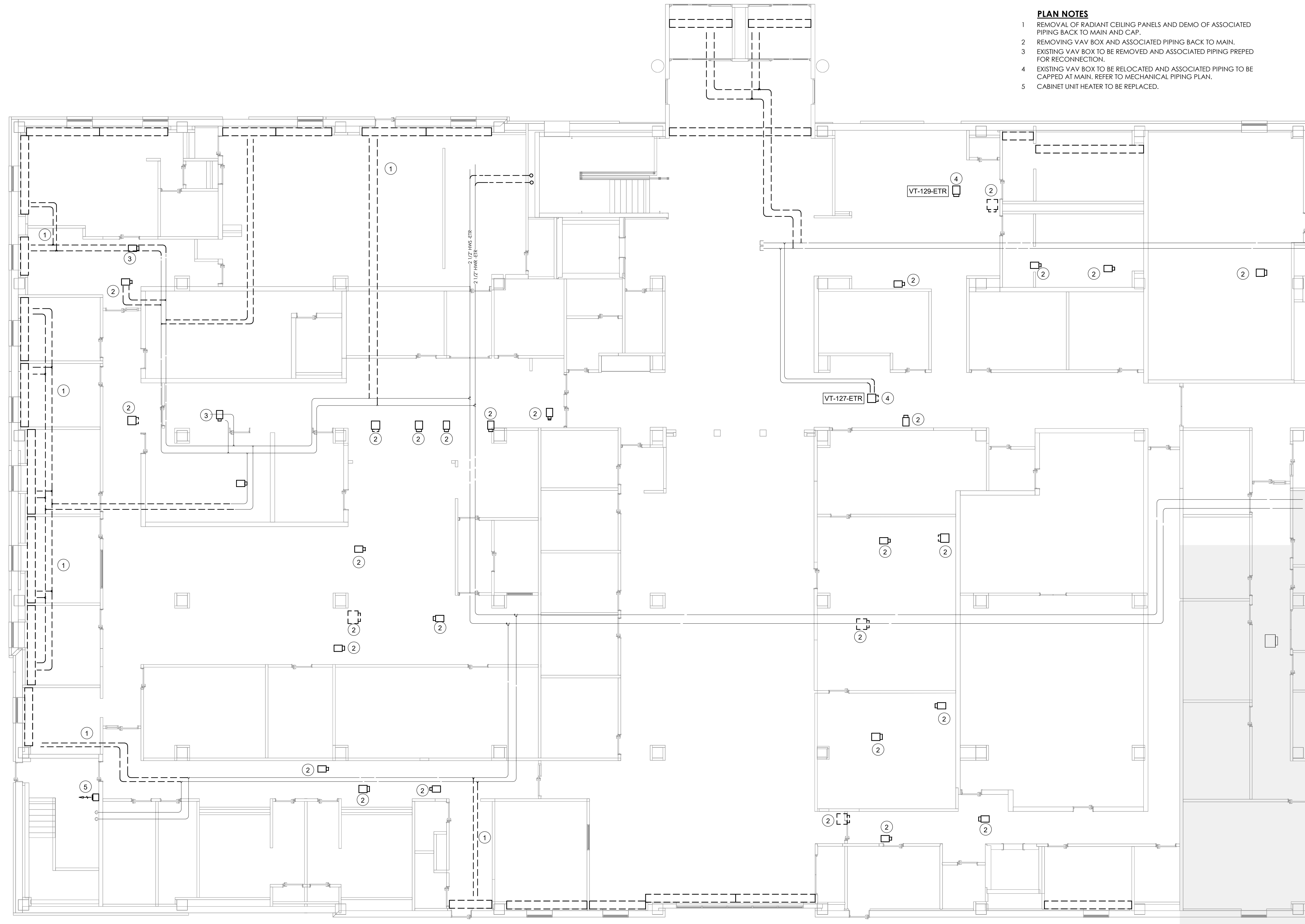
**MAIN LEVEL CPED
 MECHANICAL
 DEMO PLAN**

1 MD100
 1/8" = 1'-0"



KEY PLAN - CPED
 NTS

MD100



- PLAN NOTES**
- 1 REMOVAL OF RADIANT CEILING PANELS AND DEMO OF ASSOCIATED PIPING BACK TO MAIN AND CAP.
 - 2 REMOVING VAV BOX AND ASSOCIATED PIPING BACK TO MAIN.
 - 3 EXISTING VAV BOX TO BE REMOVED AND ASSOCIATED PIPING PREPARED FOR RECONNECTION.
 - 4 EXISTING VAV BOX TO BE RELOCATED AND ASSOCIATED PIPING TO BE CAPPED AT MAIN. REFER TO MECHANICAL PIPING PLAN.
 - 5 CABINET UNIT HEATER TO BE REPLACED.

City of Kalamazoo - Crosstown Facility
 CPED & KDPS Workplace Renovation
 150 E Crosstown Parkway Kalamazoo MI 49001

NOT FOR
 Seal:
 REGULATORY
 APPROVAL,
 PERMITTING,
 OR
 CONSTRUCTION

Bid 08/21/2025
 © 2025, intersect studio, llc
 Project Number: 23-046

**MAIN LEVEL CPED
 HVAC PIPING
 DEMO PLAN**

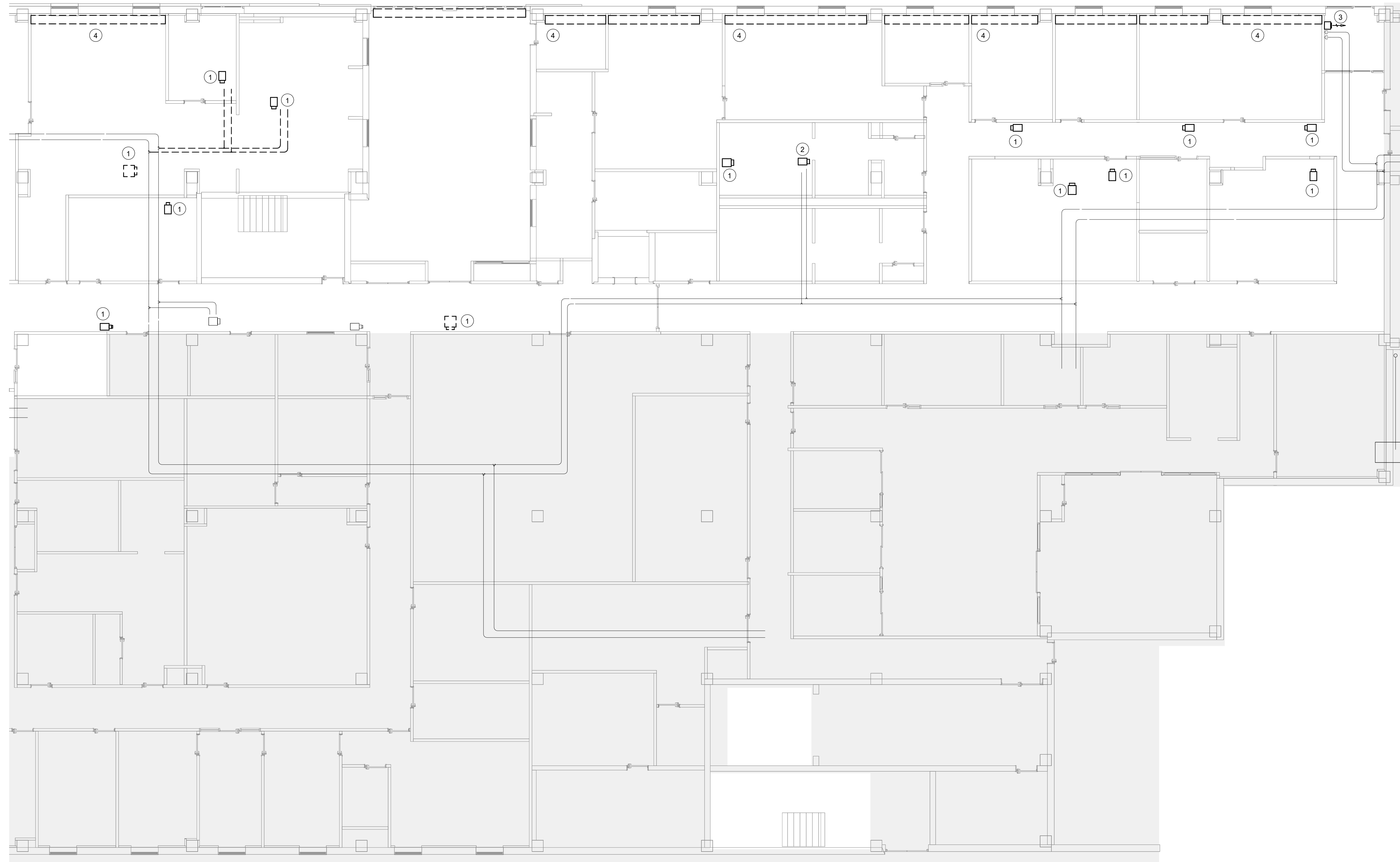
1 MAIN LEVEL CPED HVAC PIPING DEMO PLAN
 1/8" = 1'-0"

KEY PLAN - CPED
 NTS

MD200

PLAN NOTES

- 1 EXISTING VAV BOXES TO BE REMOVED AND ASSOCIATED PIPING REMOVED BACK TO MAIN AND CAPPED.
- 2 EXISTING VAV BOXES TO BE REMOVED AND ASSOCIATED PIPING PREPPED FOR RECONNECTION.
- 3 CABINET UNIT HEATER TO BE REPLACED.
- 4 REMOVAL OF RADIANT CEILING PANELS AND DEMO OF ASSOCIATED PIPING BACK TO MAIN AND CAP.



City of Kalamazoo - Crosstown Facility
 CPED & KDPS Workplace Renovation
 150 E Crosstown Parkway Kalamazoo MI 49001

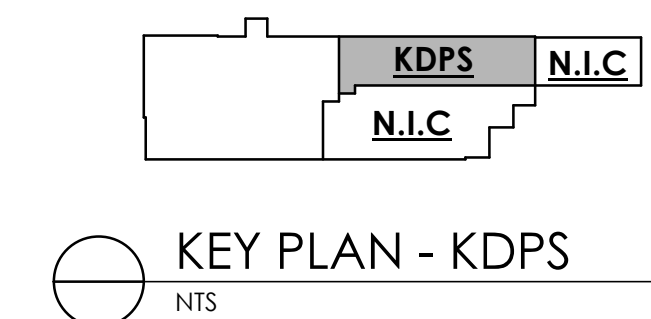
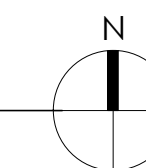
NOT FOR
 REGULATORY
 APPROVAL,
 PERMITTING,
 OR
 CONSTRUCTION

Bid 08/21/2025
 © 2025, intersect studio, llc
 Project Number: 23-046

**MAIN LEVEL KDPS
 HVAC PIPING
 DEMO PLAN**

MD201

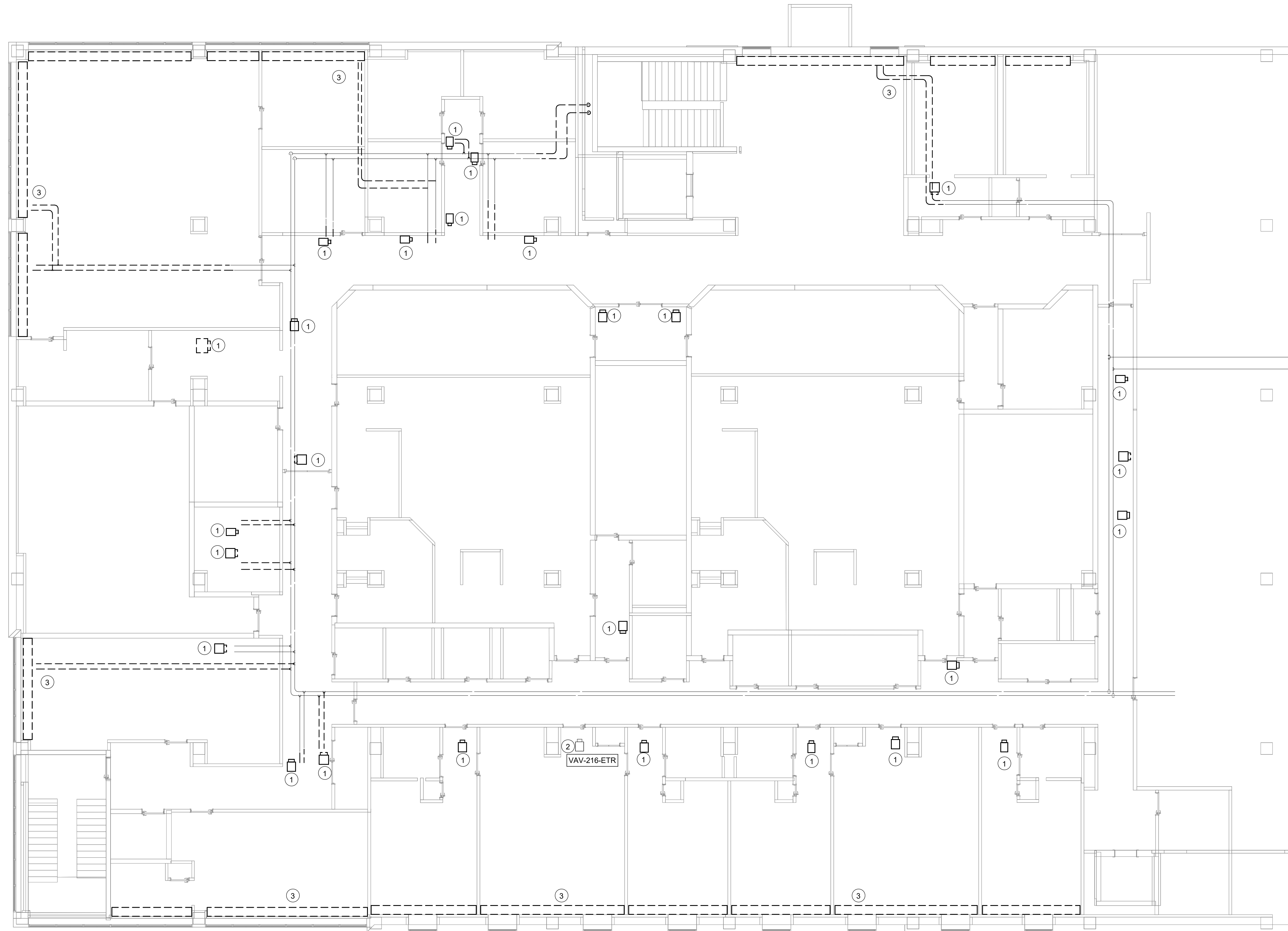
1 MD201 MAIN LEVEL KDPS HVAC PIPING DEMO PLAN
 1/8" = 1'-0"



KEY PLAN - KDPS
 NTS

PLAN NOTES

- 1 EXISTING VAV BOXES TO BE REMOVED AND ASSOCIATED PIPING REMOVED BACK TO MAIN AND CAPPED.
- 2 EXISTING VAV BOX TO REMAIN.
- 3 REMOVAL OF RADIANT CEILING PANELS AND DEMO OF ASSOCIATED PIPING BACK TO MAIN AND CAP.



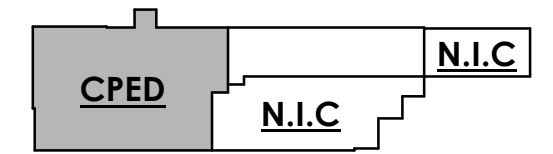
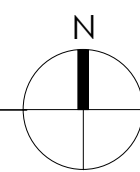
City of Kalamazoo - Crosstown Facility
 CPED & KDPS Workplace Renovation
 150 E Crosstown Parkway Kalamazoo MI 49001

NOT FOR
 REGULATORY
 APPROVAL,
 PERMITTING,
 OR
 CONSTRUCTION

Bid 08/21/2025
 © 2025, intersect studio, llc
 Project Number: 23-046

**UPPER LEVEL CPED
 HVAC PIPING
 DEMO PLAN**

1 UPPER LEVEL CPED HVAC PIPING DEMO PLAN
 1/8" = 1'-0"



KEY PLAN - CPED
 NTS

MD202

City of Kalamazoo - Crosstown Facility
 CPED & KDPS Workplace Renovation
 150 E Crosstown Parkway Kalamazoo MI 49001

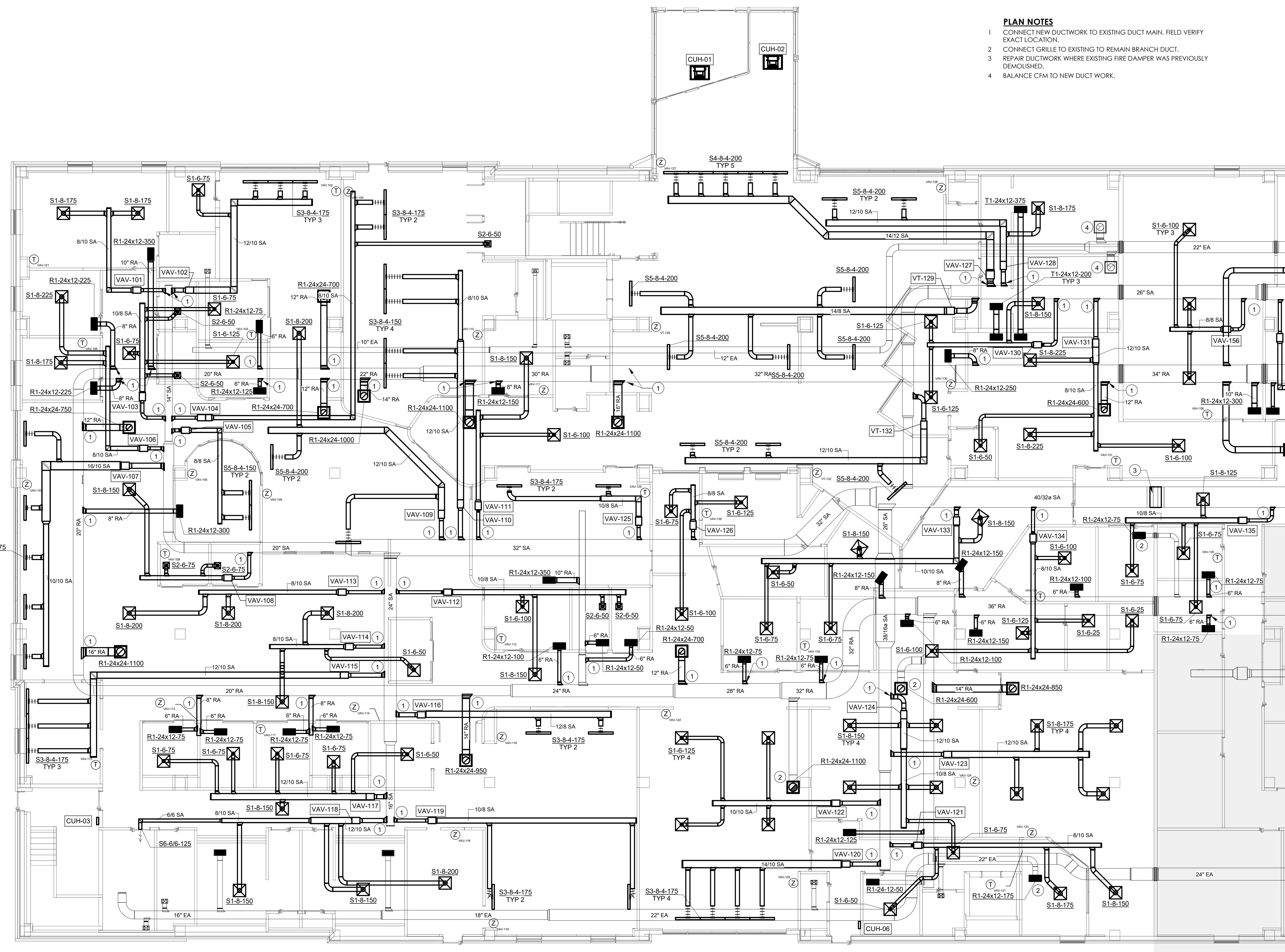
- PLAN NOTES**
1. CONNECT NEW DUCTWORK TO EXISTING DUCT MAIN, FIELD VERIFY EXACT LOCATION.
 2. CONNECT GRILLE TO EXISTING TO REMAIN BRANCH DUCT.
 3. REPAIR DUCTWORK WHERE EXISTING FIRE DAMPER WAS PREVIOUSLY DEMOLISHED.
 4. BALANCE CFM TO NEW DUCT WORK.

NOT FOR
 REGULATORY
 APPROVAL,
 PERMITTING,
 OR
 CONSTRUCTION

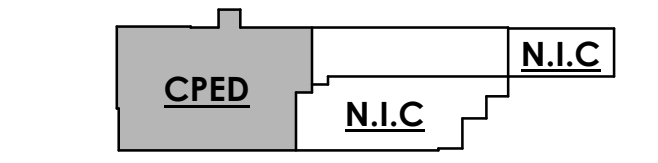
Bid 08/21/2025
 © 2025, intersect studio, llc
 Project Number: 23-046

MAIN LEVEL CPED
 MECHANICAL
 PLAN

M100



MAIN LEVEL CPED MECHANICAL PLAN
 1/8" = 1'-0"

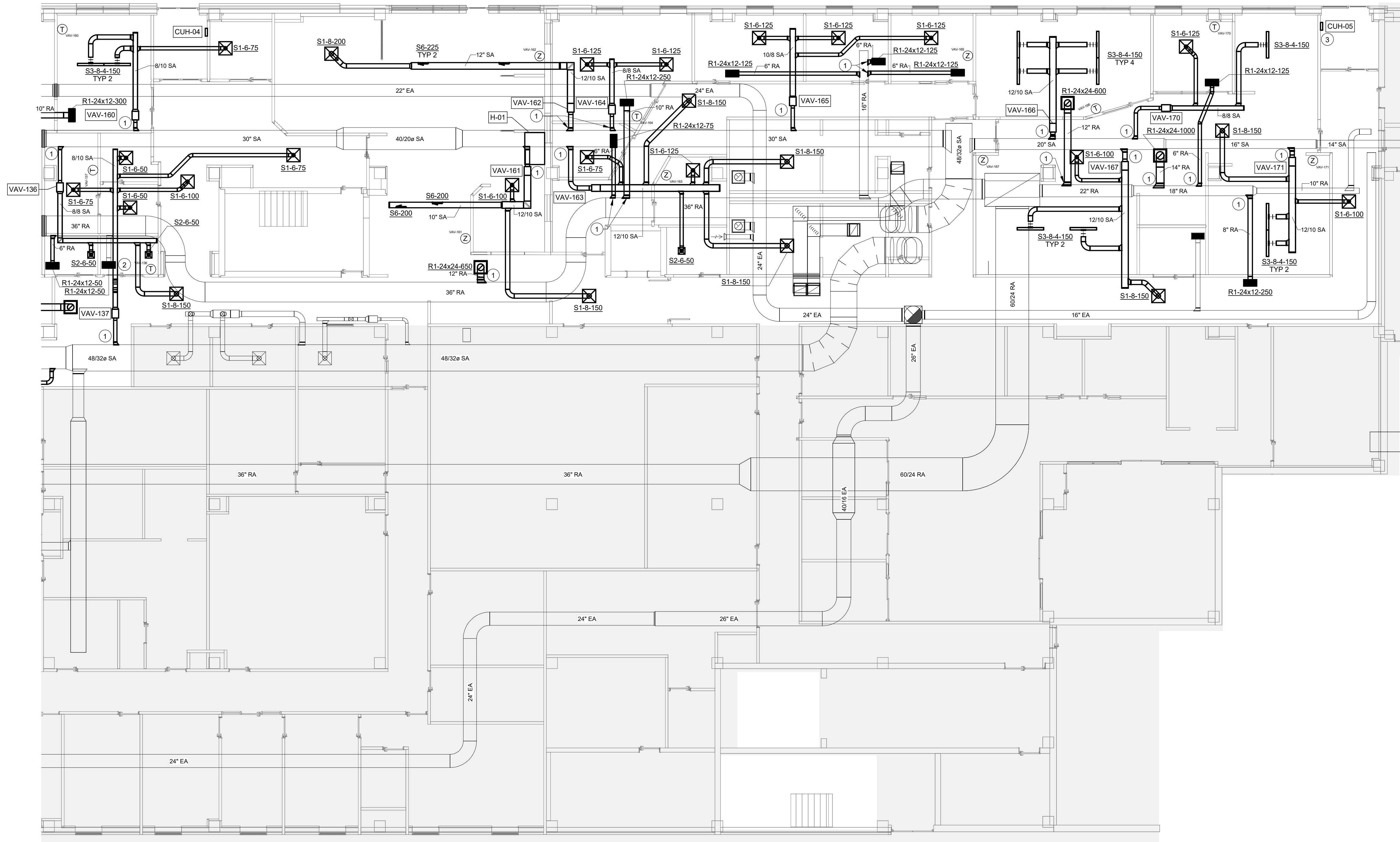


KEY PLAN - CPED
 NTS

8/20/2025 12:26:47 Autodesk Docs://2400.kalamazoo.com/Drawings/CPED/WorkplaceRenovation/M100/CPEDMechanicalPlan

PLAN NOTES

- 1 CONNECT NEW DUCTWORK TO EXISTING MAIN.
- 2 CONNECT GRILLE TO THE EXISTING TO REMAIN BRANCH DUCT.
- 3 CONNECT NEW CABINET HEATER TO EXISTING PIPING.



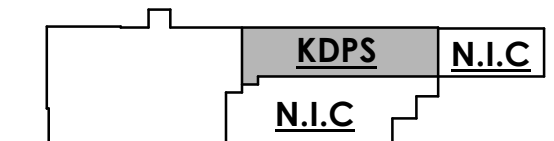
City of Kalamazoo - Crosstown Facility
 CPED & KDPS Workplace Renovation
 150 E Crosstown Parkway Kalamazoo MI 49001

NOT FOR
 REGULARITY
 APPROVAL,
 PERMITTING,
 OR
 CONSTRUCTION

Bid 08/21/2025
 © 2025, intersect studio, llc
 Project Number: 23-046

**MAIN LEVEL KDPS
 MECHANICAL
 PLAN**

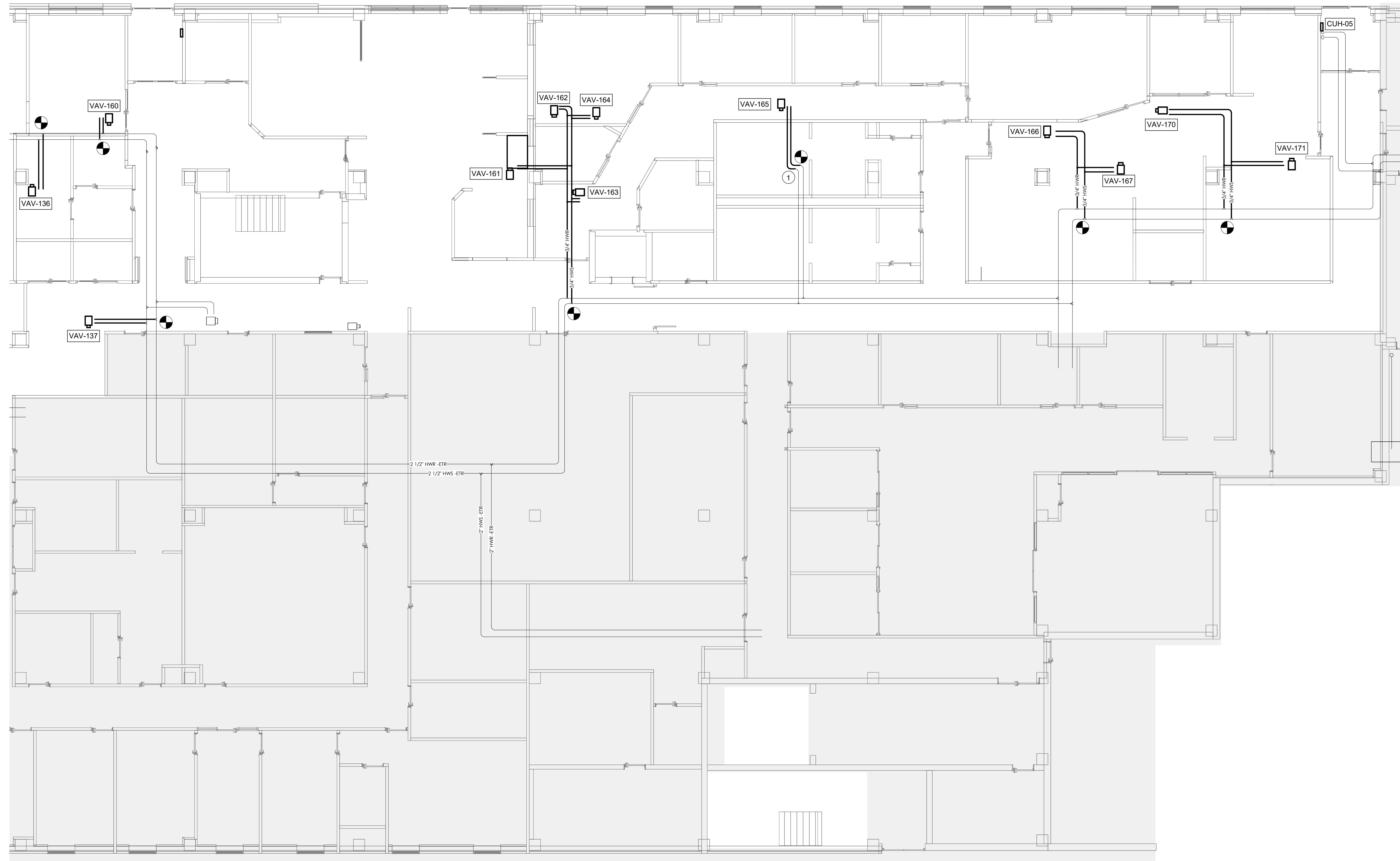
1 MAIN LEVEL KDPS MECHANICAL PLAN
 1/8" = 1'-0"



KEY PLAN - KDPS
 NTS

M101

PLAN NOTES
 1 CONNECT VAV BOX TO EXISTING PIPE.



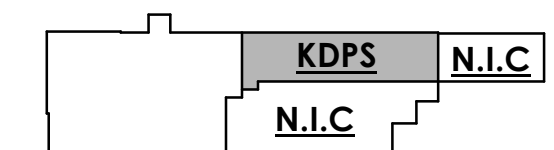
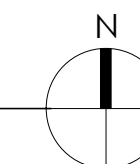
City of Kalamazoo - Crosstown Facility
 CPED & KDPS Workplace Renovation
 150 E Crosstown Parkway Kalamazoo MI 49001

NOT FOR
 REGULATORY
 APPROVAL,
 PERMITTING,
 OR
 CONSTRUCTION

Bid 08/21/2025
 © 2025, intersect studio, llc
 Project Number: 23-046

**MAIN LEVEL KDPS
 HVAC PIPING PLAN**

1 MAIN LEVEL KDPS HVAC PIPING PLAN
 M201 1/8" = 1'-0"

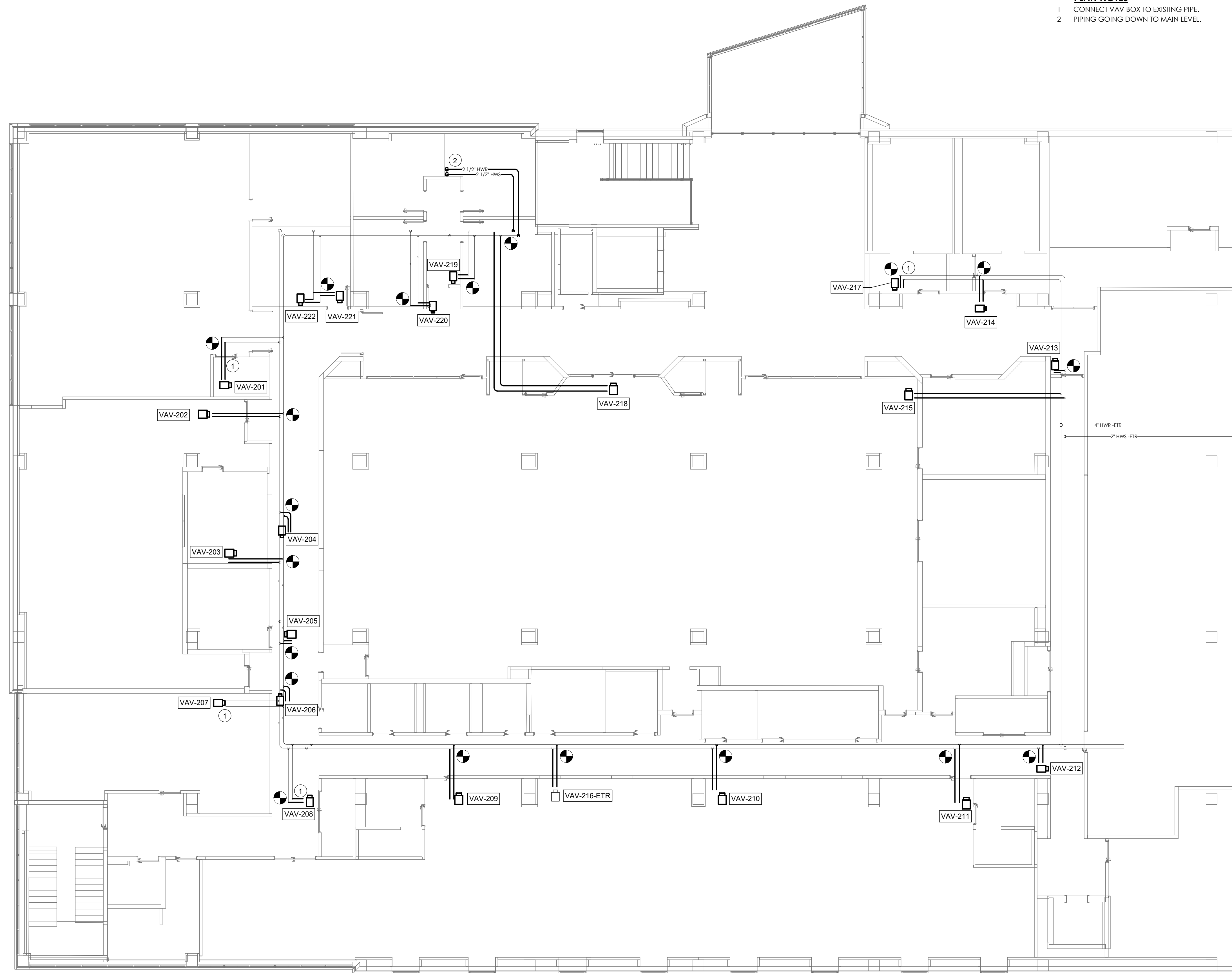


KEY PLAN - KDPS
 NTS

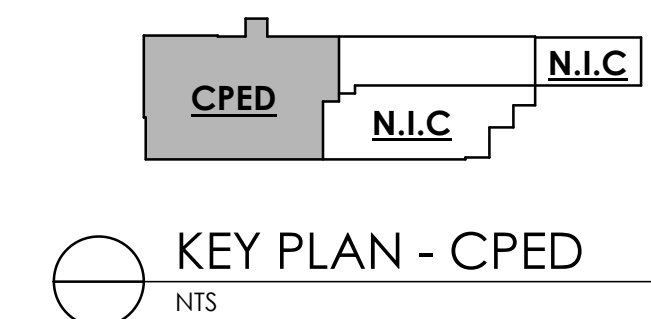
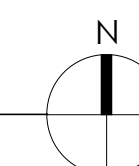
M201

8/20/2025, 12:26:24 Autodesk Docs://2430 Kalamazoo Crosstown Facility Renovation/2430 Kalamazoo MEP.rvt

- PLAN NOTES**
- 1 CONNECT VAV BOX TO EXISTING PIPE.
 - 2 PIPING GOING DOWN TO MAIN LEVEL.



1 UPPER LEVEL CPED HVAC PIPING PLAN
M202 1/8" = 1'-0"



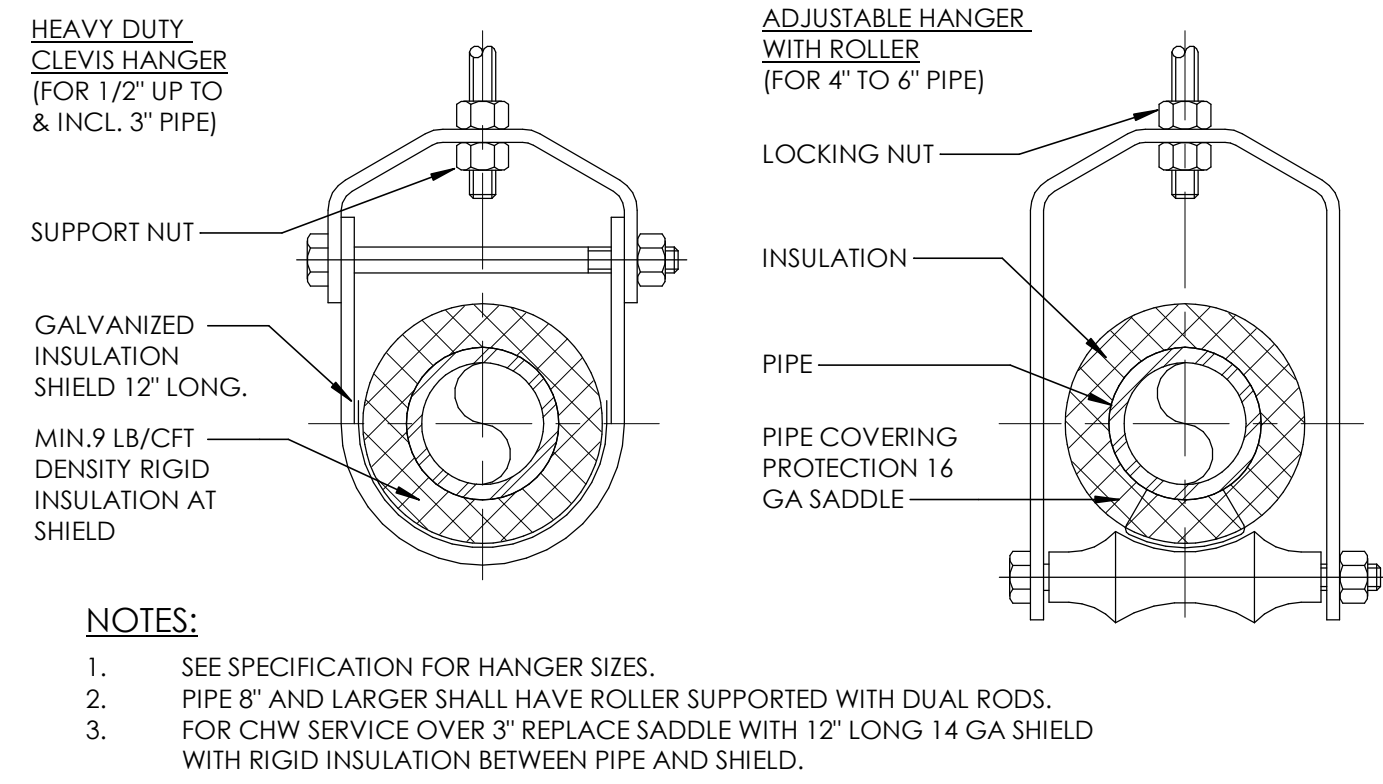
City of Kalamazoo - Crosstown Facility
CPED & KDPS Workplace Renovation
150 E Crosstown Parkway Kalamazoo MI 49001

NOT FOR
REGULATORY
APPROVAL,
PERMITTING,
OR
CONSTRUCTION

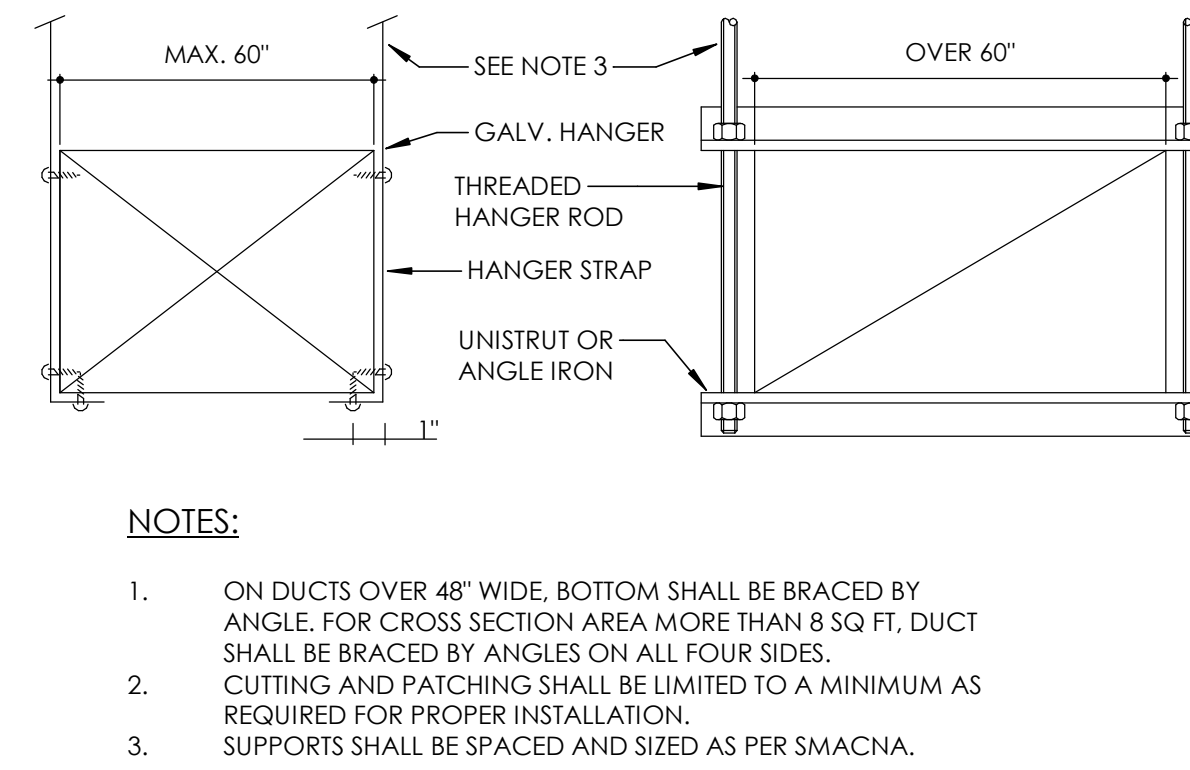
Bid 08/21/2025
© 2025, intersect studio, llc
Project Number: 23-046

UPPER LEVEL CPED
HVAC PIPING
PLAN

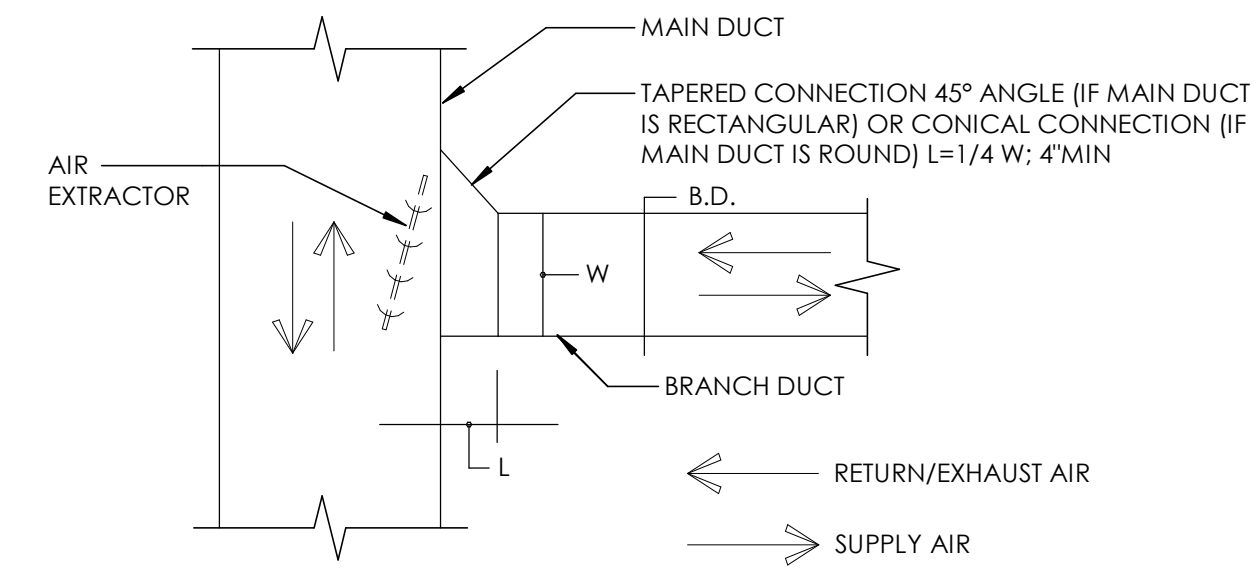
M202



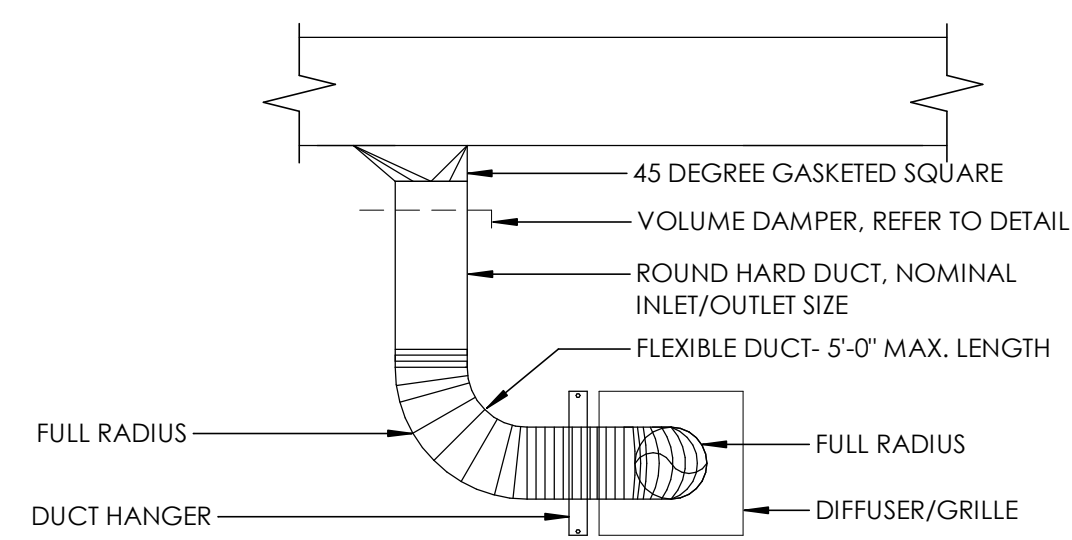
2 PIPE HANGER SUPPORT DETAIL
M501 NOT TO SCALE



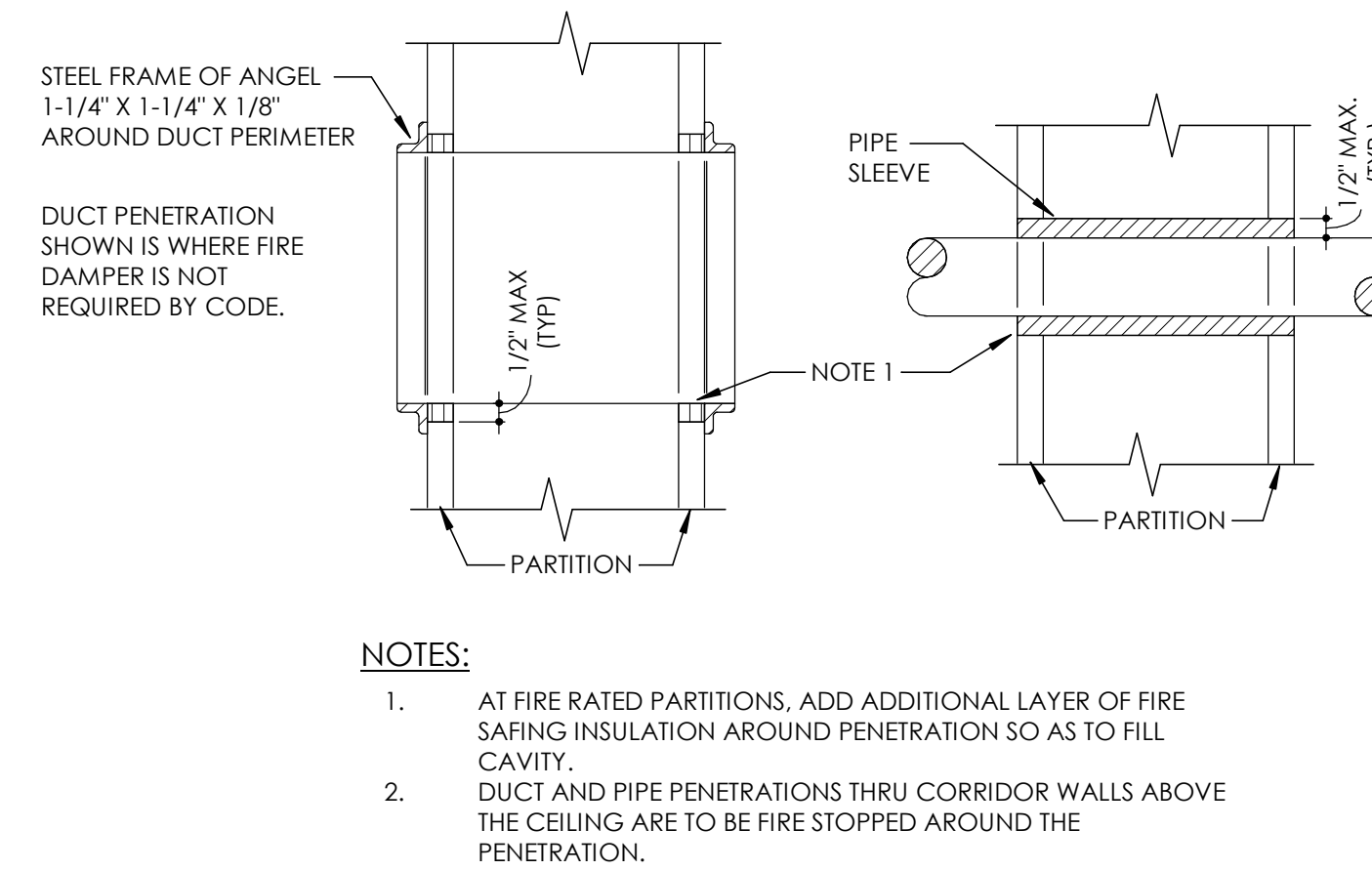
3 DUCT HANGER SUPPORT DETAIL
M501 NOT TO SCALE



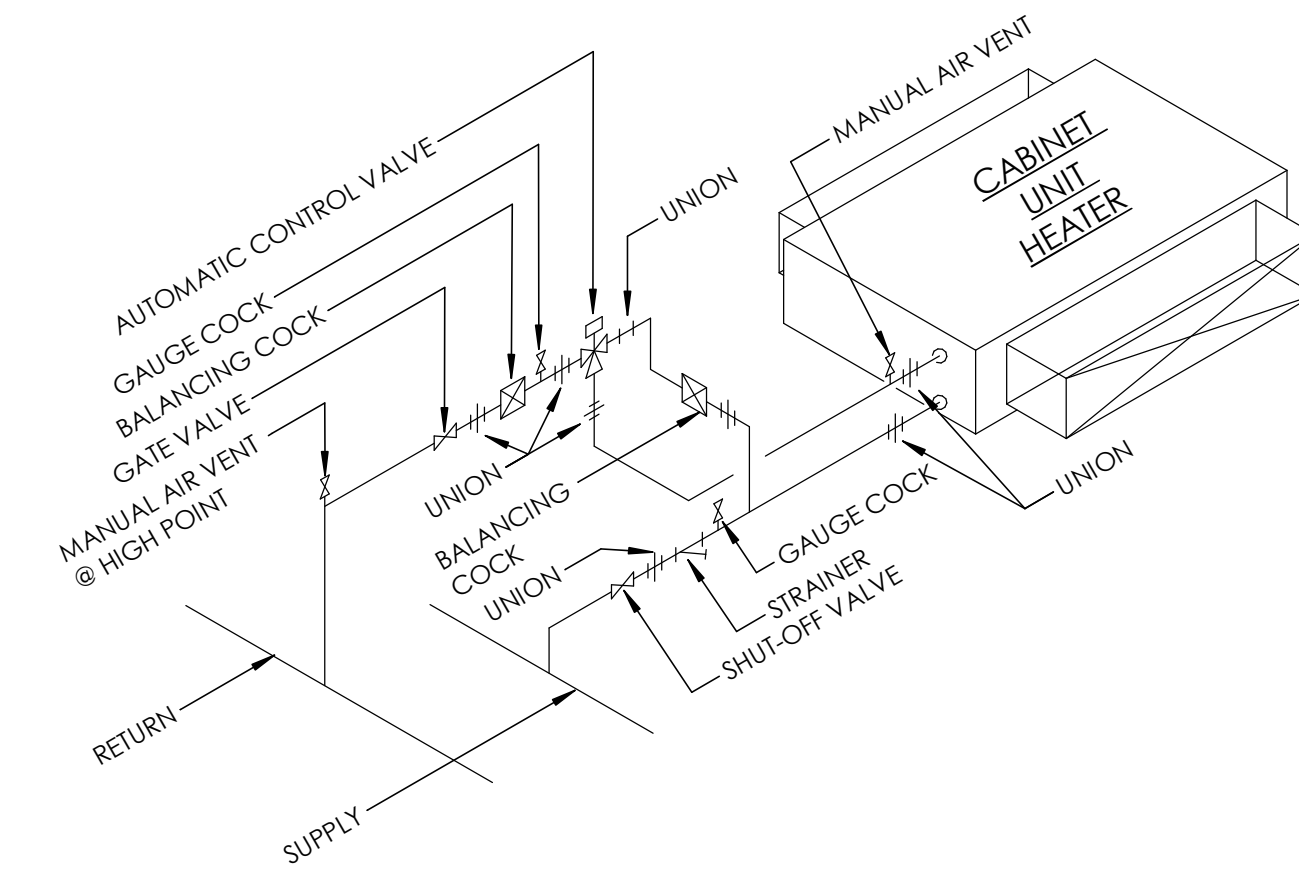
8 BRANCH TAKE-OFFS DETAIL
M501 NOT TO SCALE



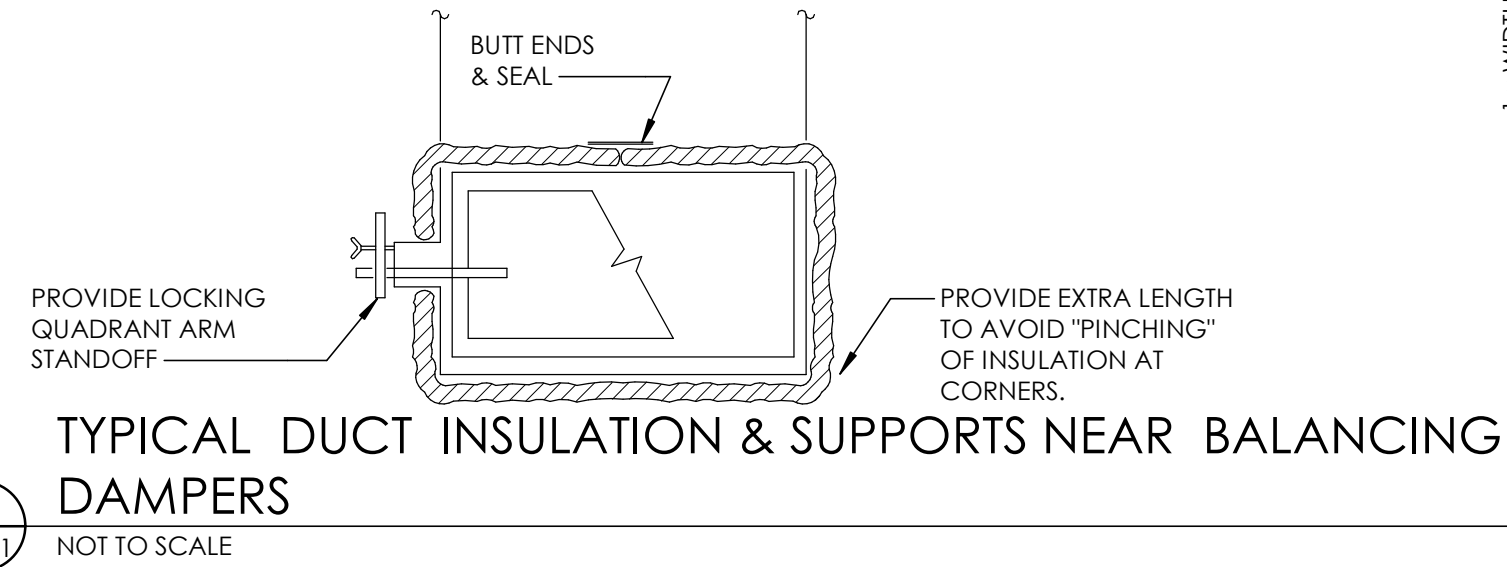
12 DUCT DIFFUSER CONNECTION
M501 NOT TO SCALE



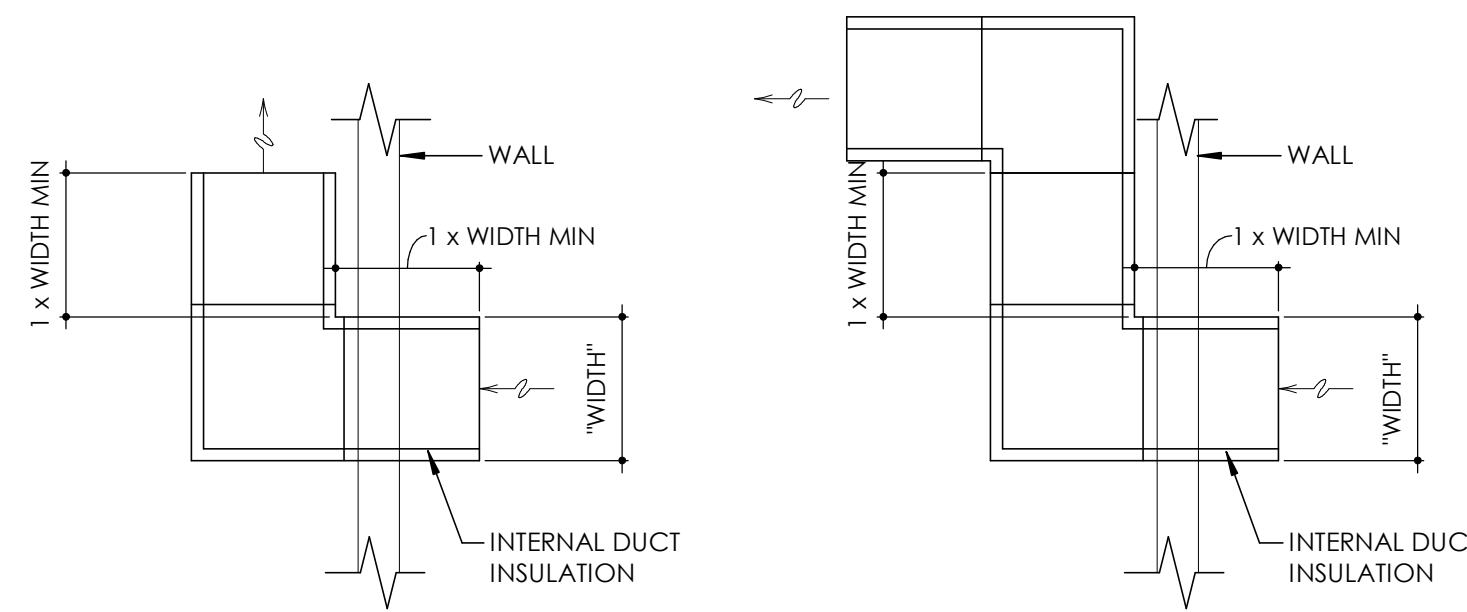
4 DUCT AND PIPE PENETRATIONS
M501 NOT TO SCALE



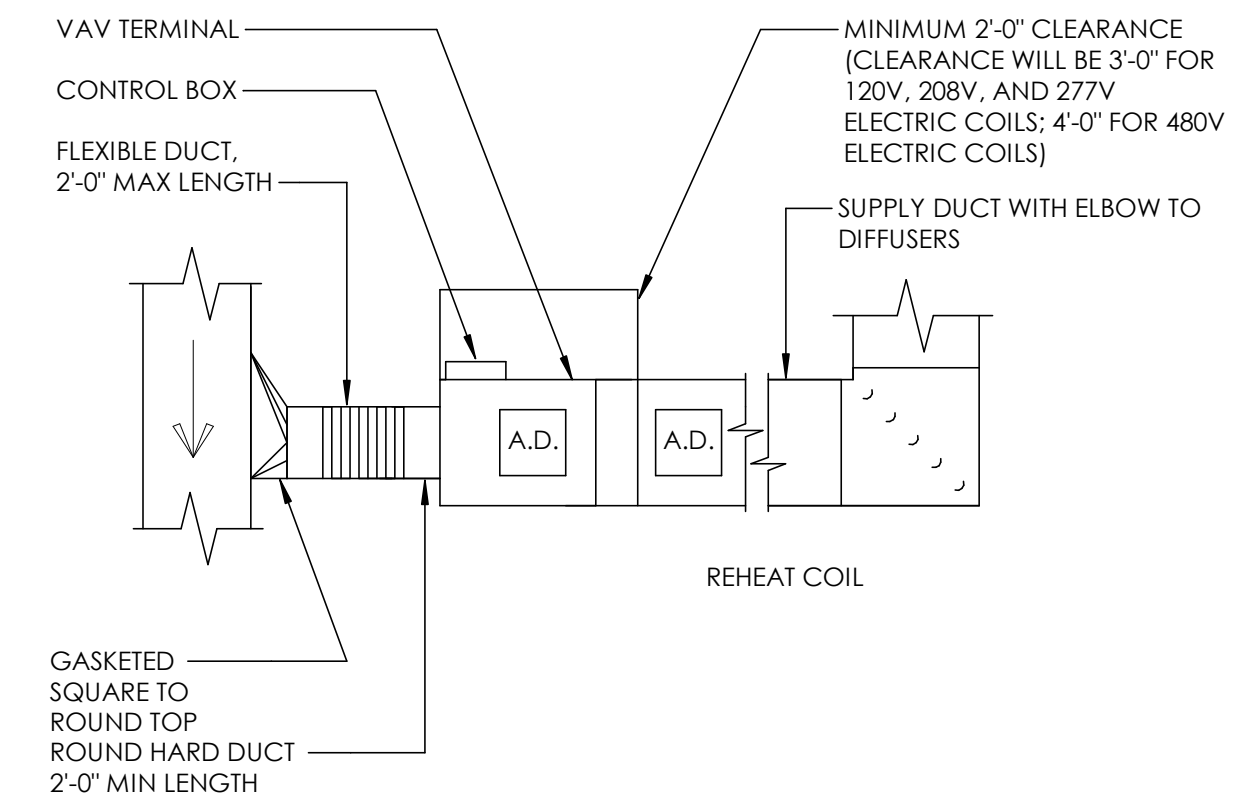
10 CABINET UNIT HEATER PIPING DIAGRAM
M501 NOT TO SCALE



9 TYPICAL DUCT INSULATION & SUPPORTS NEAR BALANCING DAMPERS
M501 NOT TO SCALE



17 DUCT- \"L\" & \"Z\" SHAPED TRANSFER
M501 NOT TO SCALE



19 DUCT VARIABLE AIR VOLUME TERMINAL WITH REHEAT COIL
M501 NOT TO SCALE

City of Kalamazoo - Crosstown Facility
CPED & KDPS Workplace Renovation
150 E Crosstown Parkway Kalamazoo MI 49001

NOT FOR
Seal:
REGULATORY
APPROVAL,
PERMITTING,
OR
CONSTRUCTION

Bid 08/21/2025
© 2025, intersect studio, llc
Project Number: 23-046

MECHANICAL
DETAILS

M501

VARIABLE AIR VOLUME TERMINAL BOX (VAV) SCHEDULE (MAIN LEVEL)																
MARK	MANUFACTURER	MODEL	AIRFLOW		REHEAT COIL DATA											REMARKS
			MAX CFM	MIN CFM	REHEAT CFM	CAPACITY MBH	ROWS	FLOW GPM	EAT F	LAT F	EWI F	LWT F	COIL FPI	APD IN WC	WPD FT	
VAV-101	TUTTLE AND BAILEY	SDV 06	350	200	200	8.5	1	2.0	55	94	180	171	10	0.04	1.8	1-6
VAV-102	TUTTLE AND BAILEY	SDV 08	600	300	300	10.7	1	1.0	55	88	180	158	10	0.04	0.7	1-6
VAV-103	TUTTLE AND BAILEY	SDV 06	375	150	150	6.8	1	1.0	55	97	180	166	10	0.02	0.5	1-6
VAV-104	TUTTLE AND BAILEY	SDV 06	400	200	200	7.8	1	1.0	55	91	180	164	10	0.04	0.5	1-6
VAV-105	TUTTLE AND BAILEY	SDV 06	300	150	150	6.8	1	1.0	55	97	180	166	10	0.02	0.5	1-6
VAV-106	TUTTLE AND BAILEY	SDV 06	400	150	150	6.8	1	1.0	55	97	180	166	10	0.02	0.5	1-6
VAV-107	TUTTLE AND BAILEY	SDV 10	875	500	500	18.1	1	3.0	55	89	180	168	10	0.06	0.9	1-6
VAV-108	TUTTLE AND BAILEY	SDV 06	300	150	150	6.8	1	1.0	55	97	180	166	10	0.02	0.5	1-6
VAV-109	TUTTLE AND BAILEY	SDV 08	600	300	300	10.7	1	1.0	55	88	180	158	10	0.04	0.7	1-6
VAV-110	TUTTLE AND BAILEY	SDV 08	600	300	300	10.7	1	1.0	55	88	180	158	10	0.04	0.7	1-6
VAV-111	TUTTLE AND BAILEY	SDV 06	250	150	150	6.8	1	1.0	55	97	180	166	10	0.02	0.5	1-6
VAV-112	TUTTLE AND BAILEY	SDV 06	350	150	150	6.8	1	1.0	55	97	180	166	10	0.02	0.5	1-6
VAV-113	TUTTLE AND BAILEY	SDV 06	400	200	200	7.8	1	1.0	55	91	180	164	10	0.04	0.5	1-6
VAV-114	TUTTLE AND BAILEY	SDV 06	400	200	200	7.8	1	1.0	55	91	180	164	10	0.04	0.5	1-6
VAV-115	TUTTLE AND BAILEY	SDV 08	525	200	200	8.9	1	1.0	55	96	180	162	10	0.02	0.7	1-6
VAV-116	TUTTLE AND BAILEY	SDV 06	350	250	250	8.3	1	1.0	55	86	180	163	10	0.05	0.5	1-6
VAV-117	TUTTLE AND BAILEY	SDV 08	500	200	200	8.9	1	1.0	55	96	180	162	10	0.02	0.7	1-6
VAV-118	TUTTLE AND BAILEY	SDV 08	625	300	300	10.7	1	1.0	55	88	180	158	10	0.04	0.7	1-6
VAV-119	TUTTLE AND BAILEY	SDV 06	350	200	200	7.8	1	1.0	55	91	180	164	10	0.04	0.5	1-6
VAV-120	TUTTLE AND BAILEY	SDV 08	700	300	300	10.7	1	1.0	55	88	180	158	10	0.04	0.7	1-6
VAV-121	TUTTLE AND BAILEY	SDV 06	375	200	200	8.5	1	2.0	55	94	180	171	10	0.04	1.8	1-6
VAV-122	TUTTLE AND BAILEY	SDV 08	500	200	200	8.9	1	1.0	55	96	180	162	10	0.02	0.7	1-6
VAV-123	TUTTLE AND BAILEY	SDV 08	700	300	300	10.7	1	1.0	55	88	180	158	10	0.04	0.7	1-6
VAV-124	TUTTLE AND BAILEY	SDV 08	675	300	300	10.7	1	1.0	55	88	180	158	10	0.04	0.7	1-6
VAV-125	TUTTLE AND BAILEY	SDV 06	350	250	250	8.3	1	1.0	55	86	180	163	10	0.05	0.5	1-6
VAV-126	TUTTLE AND BAILEY	SDV 06	300	150	150	6.8	1	1.0	55	97	180	166	10	0.02	0.5	1-6
VAV-127	ETR	--	1,000	500	500	18.1	1	3.0	55	89	180	168	10	0.06	0.9	1-6
VAV-128	TUTTLE AND BAILEY	SDV 08	575	300	300	11.8	1	2.0	55	91	180	168	10	0.04	2.5	1-6
VAV-129	ETR	--	1,000	500	500	18.1	1	3.0	55	89	180	168	10	0.06	0.9	1-6
VAV-130	TUTTLE AND BAILEY	SDV 06	400	200	200	7.8	1	1.0	55	91	180	164	10	0.04	0.5	1-6
VAV-131	TUTTLE AND BAILEY	SDV 08	600	300	300	10.7	1	1.0	55	88	180	158	10	0.04	0.7	1-6
VAV-132	TUTTLE AND BAILEY	SDV 08	600	300	300	10.7	1	1.0	55	88	180	158	10	0.04	0.7	1-6
VAV-133	TUTTLE AND BAILEY	SDV 08	500	200	200	8.9	1	1.0	55	96	180	162	10	0.02	0.7	1-6
VAV-134	TUTTLE AND BAILEY	SDV 06	375	150	150	6.8	1	1.0	55	97	180	166	10	0.02	0.5	1-6
VAV-135	TUTTLE AND BAILEY	SDV 06	350	150	150	6.8	1	1.0	55	97	180	166	10	0.02	0.5	1-6
VAV-136	TUTTLE AND BAILEY	SDV 06	250	150	150	6.8	1	1.0	55	97	180	166	10	0.02	0.5	1-6
VAV-137	TUTTLE AND BAILEY	SDV 06	350	150	150	6.8	1	1.0	55	97	180	166	10	0.02	0.5	1-6
VAV-156	TUTTLE AND BAILEY	SDV 06	300	250	250	8.3	1	1.0	55	86	180	163	10	0.05	0.5	1-6
VAV-160	TUTTLE AND BAILEY	SDV 06	375	150	150	6.8	1	1.0	55	97	180	166	10	0.02	0.5	1-6
VAV-161	TUTTLE AND BAILEY	SDV 08	650	300	300	10.7	1	1.0	55	88	180	158	10	0.04	0.7	1-6
VAV-162	TUTTLE AND BAILEY	SDV 08	650	300	300	11.8	1	2.0	55	91	180	168	10	0.04	2.5	1-6
VAV-163	TUTTLE AND BAILEY	SDV 08	700	300	300	10.7	1	1.0	55	88	180	158	10	0.04	0.7	1-6
VAV-164	TUTTLE AND BAILEY	SDV 06	250	150	150	6.8	1	1.0	55	97	180	166	10	0.02	0.5	1-6
VAV-165	TUTTLE AND BAILEY	SDV 06	375	200	200	8.5	1	2.0	55	94	180	171	10	0.04	1.8	1-6
VAV-166	TUTTLE AND BAILEY	SDV 08	600	300	300	10.7	1	1.0	55	88	180	158	10	0.04	0.7	1-6
VAV-167	TUTTLE AND BAILEY	SDV 08	550	300	300	10.7	1	1.0	55	88	180	158	10	0.04	0.7	1-6
VAV-170	TUTTLE AND BAILEY	SDV 06	275	150	150	6.8	1	1.0	55	97	180	166	10	0.02	0.5	1-6
VAV-171	TUTTLE AND BAILEY	SDV 08	550	200	200	8.9	1	1.0	55	96	180	162	10	0.02	0.7	1-6

REMARKS:

1. PROVIDE HANGER KIT MOUNTED FROM STRUCTURE ABOVE.
2. PROVIDE ACCESS PANEL IN HARD CEILINGS.
3. BACNET INTERFACE TIED INTO BAS.
4. TERMINAL BOXES SIZED AT MAXIMUM 23 DIS. NC AND MAXIMUM 23 RAD. NC PROVIDE 1/2" INSULATION LINER.
5. SEE PLANS FOR INTENDED LEFT HAND / RIGHT HAND ORIENTATION. COORDINATE FINAL LH/RH PRIOR TO SUBMITTING EQUIPMENT FOR APPROVAL.
6. REFER TO PLANS FOR ZONE SENSOR / THERMOSTAT LOCATIONS, RELOCATIONS IN PUBLIC AREAS TO BE APPROVED BY ARCHITECT. COORDINATE LOCATIONS WITH OTHER TRADES PRIOR TO ROUGH-IN.

City of Kalamazoo - Crosstown Facility
 CPED & KDPS Workplace Renovation
 150 E Crosstown Parkway Kalamazoo MI 49001

NOT FOR
 REGULATORY
 APPROVAL,
 PERMITTING,
 OR
 CONSTRUCTION

Bid 08/21/2025
 © 2025, intersect studio, llc
 Project Number: 23-046

MECHANICAL SCHEDULES

M601

VARIABLE AIR VOLUME TERMINAL BOX (VAV) SCHEDULE (UPPER LEVEL)																
MARK	MANUFACTURER	MODEL	AIRFLOW		REHEAT COIL DATA											REMARKS
			MAX CFM	MIN CFM	REHEAT CFM	CAPACITY MBH	ROWS	FLOW GPM	EAT F	LAT F	EWT F	LWT F	COIL FPI	APD FT	WPD FT	
VAV-201	TUTTLE AND BAILEY	SDV 08	700	300	300	10.7	1	1.0	55	88	180	158	10	0.04	0.7	1-6
VAV-202	TUTTLE AND BAILEY	SDV 10	1,050	500	500	18.1	1	3.0	55	89	180	168	10	0.06	0.9	1-6
VAV-203	TUTTLE AND BAILEY	SDV 10	1,000	500	500	14.6	1	1.0	55	82	180	150	10	0.06	0.1	1-6
VAV-204	TUTTLE AND BAILEY	SDV 06	350	150	150	6.8	1	1.0	55	97	180	166	10	0.02	0.5	1-6
VAV-205	TUTTLE AND BAILEY	SDV 10	1,050	700	700	16.3	1	1.0	55	77	180	147	10	0.10	0.1	1-6
VAV-206	TUTTLE AND BAILEY	SDV 06	300	150	150	6.8	1	1.0	55	97	180	166	10	0.02	0.5	1-6
VAV-207	TUTTLE AND BAILEY	SDV 10	900	500	500	18.1	1	3.0	55	89	180	168	10	0.06	0.9	1-6
VAV-208	TUTTLE AND BAILEY	SDV 08	550	300	300	10.7	1	1.0	55	88	180	158	10	0.04	0.7	1-6
VAV-209	TUTTLE AND BAILEY	SDV 10	1,125	500	500	18.1	1	3.0	55	89	180	168	10	0.06	0.9	1-6
VAV-210	TUTTLE AND BAILEY	SDV 10	1,125	500	500	18.1	1	3.0	55	89	180	168	10	0.06	0.9	1-6
VAV-211	TUTTLE AND BAILEY	SDV 10	1,125	500	500	18.1	1	3.0	55	89	180	168	10	0.06	0.9	1-6
VAV-212	TUTTLE AND BAILEY	SDV 08	550	200	200	8.9	1	1.0	55	96	180	162	10	0.02	0.7	1-6
VAV-213	TUTTLE AND BAILEY	SDV 08	700	300	300	10.7	1	1.0	55	88	180	158	10	0.04	0.7	1-6
VAV-214	TUTTLE AND BAILEY	SDV 06	400	200	200	8.5	1	2.0	55	94	180	171	10	0.04	1.8	1-6
VAV-215	TUTTLE AND BAILEY	SDV 10	1,050	700	700	16.3	1	1.0	55	77	180	147	10	0.10	0.1	1-6
VAV-216	ETR	--	1,100	700	700	16.3	1	1.0	55	77	180	147	10	0.10	0.1	1-6
VAV-217	TUTTLE AND BAILEY	SDV 08	700	350	350	12.7	1	2.0	55	89	180	167	10	0.06	2.5	1-6
VAV-218	TUTTLE AND BAILEY	SDV 10	1,050	700	700	16.3	1	1.0	55	77	180	147	10	0.10	0.1	1-6
VAV-219	TUTTLE AND BAILEY	SDV 06	250	150	150	6.8	1	1.0	55	97	180	166	10	0.02	0.5	1-6
VAV-220	TUTTLE AND BAILEY	SDV 06	350	150	150	6.8	1	1.0	55	97	180	166	10	0.02	0.5	1-6
VAV-221	TUTTLE AND BAILEY	SDV 06	250	150	150	6.8	1	1.0	55	97	180	166	10	0.02	0.5	1-6
VAV-222	TUTTLE AND BAILEY	SDV 06	250	150	150	6.8	1	1.0	55	97	180	166	10	0.02	0.5	1-6

REMARKS:

1. PROVIDE HANGER KIT MOUNTED FROM STRUCTURE ABOVE.
2. PROVIDE ACCESS PANEL IN HARD CEILINGS.
3. BACNET INTERFACED INTO BAS.
4. TERMINAL BOXES SIZED AT MAXIMUM 23 DIS. NC AND MAXIMUM 23 RAD. NC PROVIDE 1/2" INSULATION LINER.
5. SEE PLANS FOR INTENDED LEFT HAND / RIGHT HAND ORIENTATION. COORDINATE FINAL LH/RH PRIOR TO SUBMITTING EQUIPMENT FOR APPROVAL.
6. REFER TO PLANS FOR ZONE SENSOR / THERMOSTAT LOCATIONS, RELOCATIONS IN PUBLIC AREAS TO BE APPROVED BY ARCHITECT. COORDINATE LOCATIONS WITH OTHER TRADES PRIOR TO ROUGH-IN.

CABINET UNIT HEATER (CUH) SCHEDULE													
MARK	MANUFACTURER	MODEL	TYPE	MOUNTING LOCATION	HEATING DATA				ELECTRICAL DATA			WEIGHT LBS	REMARKS
					CAPACITY MBH	EWT F	LWT F	FLOW GPM	VOLTAGE	MCA	MOCP		
CUH-01	VULCAN	RC-04	CEILING RECESSED	VESTIBULE 170	29.0	180	160	2.5	120/1	1.4	15	135	1-3
CUH-02	VULCAN	RC-04	CEILING RECESSED	WELCOME 171	29.0	180	160	2.5	120/1	1.4	15	135	1-3
CUH-03	VULCAN	W-04	WALL SURFACE MTD	STAIR S-1	29.0	180	160	2.5	120/1	0.8	15	128	1-3
CUH-04	VULCAN	W-02	WALL SURFACE MTD	VESTIBULE 193	16.2	180	160	1.5	120/1	0.8	15	97	1-3
CUH-05	VULCAN	W-02	WALL SURFACE MTD	VESTIBULE 267	16.2	180	160	1.5	120/1	0.8	15	97	1-3
CUH-06	VULCAN	W-02	WALL SURFACE MTD	CORRIDOR 161	16.2	180	160	1.5	120/1	0.8	15	97	1-3

REMARKS:

1. DISCONNECT TO BE PROVIDED BY E.C.
2. UNIT CONTROL TO HAVE INTEGRAL THERMOSTAT.
3. ARRANGEMENT TO BE FRONT IN, FRONT OUT.

RECIRCULATION HOOD (H) SCHEDULE											
MARK	MANUFACTURER	MODEL	TYPE	SERVICE	AIRFLOW CFM	ESP IN WC	ELECTRICAL DATA			WEIGHT LBS	REMARKS
							VOLTAGE	MCA	MOCP		
H-01	GREENCHECK	GRRS-W-30-F	WALL MOUNTED RECIRCULATED	KITCHEN 197	250	0.2	120/1	1	15	90	1-6

REMARKS:

1. INTEGRAL FAN WITH FRONT RETICULATION.
2. SELF-CONTAINED INTEGRATED FIRE SUPPRESSION SYSTEM.
3. SURFACE MOUNTED MANUAL PULL STATION.
4. HOOD MOUNTED TOUCH SCREEN USER INTERFACE.
5. ELECTRICAL RANGE DISCONNECT.
6. MESH GREASE FILTER.

DIFFUSER, REGISTER, & GRILLE SCHEDULE										
MARK	MANUFACTURER	MODEL	DESCRIPTION	MATERIAL	FINISH	FRAME TYPE	SIZE	MAX NC	REMARKS	
S1	TITUS	OMNI	SQUARE PLAQUE DIFFUSER	STEEL	WHITE	SEE PLANS	2'X2' (JON)	25	--	
S2	TITUS	300FL	DOUBLE DEFLECTION LOUVERED GRILLE	STEEL	WHITE	SEE PLANS	SEE PLANS	25	--	
S3	TITUS	TBD10	T-BAR ADJUSTABLE THROW LINEAR DIFFUSER	STEEL	WHITE	LAY-IN	SINGLE 1" SLOT	25	1	
S4	TITUS	FL10	CONTINUOUS SINGLE SLOT DIFFUSER	ALUMINUM	WHITE	CONCEALED	SINGLE 1" SLOT	25	1,2,3,4	
S5	TITUS	FL10	CONTINUOUS SINGLE SLOT DIFFUSER	ALUMINUM	WHITE	CONCEALED	SINGLE 1" SLOT	25	1,2,3,5	
S6	TITUS	S300FL	DUCT MOUNTED GRILLE	STEEL	WHITE	DUCT MTD	SEE PLANS	25	--	
S7	TITUS	CT400	LINEAR BAR GRILLE	ALUMINUM	WHITE	SEE PLANS	SEE PLANS	25	3	
R1	TITUS	350FL	RECTANGULAR LOUVERED GRILLE	STEEL	WHITE	SEE PLANS	SEE PLANS	25	--	
T1	TITUS	350FL	RECTANGULAR LOUVERED GRILLE	ALUMINUM	WHITE	SEE PLANS	SEE PLANS	25	--	
E1	TITUS	350FL	RECTANGULAR LOUVERED GRILLE	ALUMINUM	WHITE	SEE PLANS	SEE PLANS	25	--	

REMARKS:

1. PROVIDE WITH CABLE OPERATED DAMPER WHERE DAMPER NOT EASILY ACCESSIBLE.
2. PROVIDE WITH CONCEALED MUD-IN FRAME WHERE INSTALLED IN HARD CEILING OR WALL.
3. WHERE TWO OR MORE DIFFUSERS / GRILLES ARE SIDE BY SIDE THEY ARE TO BE INSTALLED SO AS TO PROVIDE A CONTINUOUS APPEARANCE FOR THE ENTIRE LENGTH.
4. PROVIDE WITH JET THROW PATTERN CONTROLLER.
5. PROVIDE WITH HIGHTHROW PATTERN CONTROLLER.

City of Kalamazoo - Crosstown Facility
 CPED & KDPS Workplace Renovation
 150 E Crosstown Parkway Kalamazoo MI 49001

NOT FOR
Seal:
REGULATORY
APPROVAL,
PERMITTING,
OR
CONSTRUCTION

Bid 08/21/2025

© 2025, intersect studio, llc
Project Number: 23-046

MECHANICAL
SCHEDULES

M602

ELECTRICAL SITE NOTES:

- ELECTRICAL CONTRACTOR TO COORDINATE ALL UNDERGROUND UTILITIES WITH MECHANICAL CONTRACTOR'S SEWER, WATER AND GAS LINE LOCATIONS.
- ELECTRICAL CONTRACTOR TO PROVIDE ALL TRENCH AND BACK FILL REQUIRED FOR WORK SHOWN ON PLANS. ALL WORK IS TO COMPLY WITH DIVISION 1 REQUIREMENTS FOR UNDERGROUND UTILITIES AND TRENCH AND BACKFILL ETC.
- ALL WIRING IS TO BE #10 AWG MINIMUM THIN/WHM (40 DEG. C IN 1 1/2" SCHEDULE 40 PVC (MINIMUM SIZE). TRENCH AND BACK FILL TO 30" DEEP. CLEAN BACKFILL USING SITE MATERIALS MAY BE USED. PROVIDE PREMIUM BACKFILL WHERE SITE MATERIALS ARE NOT ACCEPTABLE FOR USE.
- ALL CONDUIT ENTRIES TO THE BUILDING SHALL FITCH AWAY FROM BUILDING WALLS. SEAL PENETRATIONS WATER/TIGHT WITH LIQUID-SEAL PPE SEALS OR APPROVED EQUIVALENT. FOR PENETRATIONS TO THE BUILDING BY ALL SERVICE CONDUITS AND CONDUITS GREATER OR EQUAL THAN 2" IN DIAMETER, PROVIDE A DUCT SEALING SYSTEM AT THE BUILDING. ACCEPTABLE DUCT SEALING SYSTEM IS RAYCHEM'S RDSS OR APPROVED EQUIVALENT.
- PROVIDE MARKING TAPE ABOVE ALL ELECTRICAL CIRCUITS. MARKING TAPE FOR SITE LIGHTING CIRCUITS TO BE 6" BELOW GRADE, 3" WIDE, RED WITH ELECTRICAL MARKINGS.
- POLE BASE COVERS ARE TO BE INSTALLED SO THAT THE BASE COVER FITS FLUSH TO THE TOP OF THE CONCRETE BASE. LEVELING SHIMS AND NUTS SHALL NOT CAUSE A GAP BETWEEN THE POLE BASE AND THE BASE COVER.
- ALL POLE BASES SHALL HAVE A HONEYCOMBING AND SONOTUBE MARKINGS FILLED AND MADE SMOOTH WITH CONCRETE AFTER TUBE REMOVAL. COAT WITH TWO (2) COATS THRU-SEAL PER MANUFACTURER'S DIRECTIONS.
- POLE BASE DESIGN MUST BE VERIFIED WITH LOCAL GRADE CONDITIONS FOR DENSITY AND CONSISTENCY.
- CUT AND PATCH EXISTING PAVINGS AS REQUIRED FOR THE INSTALLATION OF NEW WIRING WHERE PAVING EXISTS.

DEMOLITION NOTES:

- 'X' = INDICATES EXISTING DEVICE TO REMAIN.
- 'XR' = INDICATES EXISTING DEVICE TO BE REMOVED, INCLUDING ALL CONDUIT AND WIRING BACK TO PANEL OR POINT OF COMMON USE.
- 'XRL' = INDICATES EXISTING DEVICE TO BE REMOVED AND RELOCATED, REWIRE WITH LIKE KIND OR AS SHOWN ON DRAWINGS, CORRESPONDS WITH 'XNL'.
- 'XNL' = INDICATES NEW LOCATION OF RELOCATED EQUIPMENT, CORRESPONDS WITH 'XRL'.
- 'XR'D' = INDICATES EXISTING DEVICE TO BE REWORKED, REWORK AS SHOWN OR REPLACE EXISTING DEVICE WITH NEW AND REWIRE AS INDICATED.
- 'XR'D' = INDICATES EXISTING DEVICE TO BE DISCONNECTED AND ALL CONDUIT AND WIRING TO BE REMOVED.
- 'C'X' = INDICATES CONNECT EQUIPMENT OR DEVICE TO EXISTING WIRING.

GENERAL DEMOLITION NOTES:

- THIS CONTRACTOR SHALL PERFORM ALL DEMOLITION OF EXISTING ELECTRICAL SYSTEMS AS INDICATED ON ELECTRICAL AND ARCHITECTURAL PLANS OR AS NECESSARY FOR THE PROJECT. REMOVE FROM SITE AND PROPERLY DISPOSE OF ALL MATERIAL AND DEBRIS FROM THIS WORK.
- DEMOLITION DRAWINGS ARE GENERAL IN NATURE SHOWING THE SCOPE OF DEMOLITION WORK. CONTRACTOR SHALL VISIT THE SITE AND BECOME FAMILIAR WITH THE QUANTITY OF LIGHT FIXTURES, OUTLETS, ETC. REMOVE ALL EQUIPMENT AND DEVICES NO LONGER REQUIRED FOR FINISHED CONSTRUCTION. ALL EXISTING LIGHTS, CONDUIT, WIRE AND DEVICES IN PROJECT AREAS SHALL BE REMOVED AND DISPOSED OF. REMOVE CONDUITS BEYOND NEW SURFACES. REMOVE ALL EXISTING WIRE FROM CONDUIT BACK TO POINT OF COMMON USE OR TO PANELS. LABEL EXISTING CIRCUIT BREAKERS "SPARE" IF NOT REUSED FOR NEW WORK.
- DISCONNECT EXISTING EQUIPMENT IN BUILDINGS THAT IS TO BE REMOVED UNDER OTHER SECTIONS. REMOVE DATA AND PHONE CABLES SYSTEM AS DIRECTED BY OWNER. NO CABLES SHALL BE REMOVED OR CUT WITHOUT APPROVAL FROM OWNER. ANY EXISTING CABLES TO REMAIN SHALL BE SUPPORTED FROM STRUCTURE BEFORE CEILING REMOVAL.
- PATCH ALL SURFACES TO MATCH SURROUNDING FOR DEVICES TO BE REMOVED FROM EXISTING WALLS TO BE MAINTAINED. EXISTING ROUGH-IN BOXES IN WALL TO REMAIN MAY BE REUSED IF CODE COMPLYING AND APPROVED FOR LOCATION BY ARCHITECT.
- THE OWNER RESERVES THE RIGHT OF SALVAGE FOR ALL EXISTING ELECTRICAL EQUIPMENT PRIOR TO DEMOLITION. THE CONTRACTOR SHALL REMOVE ALL MATERIALS AND DELIVER TO THE OWNER THOSE REQUIRED IN THEIR EXISTING CONDITION. ALL OTHER MATERIAL SHALL BE REMOVED BY THIS CONTRACTOR.
- ALL CIRCUITS WHICH ARE REQUIRED TO REMAIN ACTIVE SHALL BE MAINTAINED OR REWORKED AS REQUIRED. ANY EXISTING CIRCUITS OR CABLES SYSTEMS SERVING AREAS NOT AFFECTED BY DEMOLITION SHALL BE MAINTAINED. ALL CIRCUITS SHALL BE VERIFIED WITH EXISTING DRAWINGS AND ACTUAL FIELD CONDITIONS PRIOR TO BEGINNING DEMOLITION.
- PHASING: CONTRACTOR IS REQUIRED TO COORDINATE THE REMOVAL AND/OR SHUTDOWN OF ANY EXISTING SYSTEMS AND ANY RELATED MECHANICAL, PLUMBING OR FIRE PROTECTION SYSTEMS REQUIRED FOR THIS PROJECT TO MAINTAIN THE EXISTING BUILDING OPERATIONS THROUGHOUT THE COURSE OF CONSTRUCTION. CONFORM TO THE PROJECT CONSTRUCTION SCHEDULE, PHASING SEQUENCE AND INTENT IDENTIFIED BY THE CONSTRUCTION MANAGER AND ARCHITECT. CONTRACTOR SHALL COORDINATE ALLOWABLE WORKING HOURS IN SPECIFIC AREAS OF THE EXISTING BUILDING WITH THE CONSTRUCTION MANAGER. IF AFTER HOURS WORK IS REQUIRED, PREMIUM TIME SHALL BE INCLUDED IN BID. ANY REQUIRED DEMOLITION, RELOCATION OR SHUTDOWN OF EXISTING SYSTEMS SHALL BE SUBMITTED FOR APPROVAL A MINIMUM OF TWO (2) WEEKS PRIOR TO PERFORMING THE REQUIRED WORK. NO DEMOLITION WORK AFFECTING EXISTING SYSTEMS TO REMAIN SHALL BE PERFORMED WITHOUT APPROVAL FROM THE CONSTRUCTION MANAGER. INCLUDE ANY TEMPORARY FACILITIES REQUIRED TO MAINTAIN EXISTING SYSTEMS IN OPERATION DURING THE COURSE OF DEMOLITION WORK IN BID.

GENERAL NOTES:

- ELECTRICAL CONTRACTOR TO COORDINATE SURFACE 4 PENDANT MOUNTED LIGHTING FIXTURE MOUNTING WITH ALL MECHANICAL, DUCTWORK AND PLUMBING PIPING. WHERE INTERFERENCES OCCUR, ELECTRICAL CONTRACTOR TO STEM MOUNT FIXTURES BELOW ALL DUCTWORK AND PIPING.
- ELECTRICAL CONTRACTOR TO REFER TO ARCHITECT'S REFLECTED CEILING PLAN FOR EXACT LOCATION AND MOUNTING HEIGHTS OF ALL LIGHT FIXTURES.
- NO DUCTWORK OR PIPING TO BE RUN ABOVE ELECTRICAL PANELS OR THROUGH ELECTRICAL OR ELEVATOR EQUIPMENT ROOMS. ELECTRICAL CONTRACTOR SHALL COORDINATE WITH ALL TRADES FOR EQUIPMENT LAYOUTS PRIOR TO ROUGH-IN OF ALL SYSTEMS.
- ALL ROOF PENETRATIONS TO BE SEALED PER ROOFING CONTRACTOR'S REQUIREMENTS.
- DO NOT INSTALL DEVICES SCALED FROM THESE DRAWINGS. EXACT LOCATIONS SHALL BE VERIFIED WITH THE OWNER OR ARCHITECT AND DIMENSIONS TAKEN IN THE FIELD.
- ELECTRICAL CONTRACTOR TO CONFIRM ALL REQUIREMENTS AND LOCATIONS OF ALL EXIT SIGNS, EMERGENCY LIGHTS AND FIRE ALARM DEVICES WITH LOCAL FIRE AUTHORITIES PRIOR TO ROUGH-IN.
- ELECTRICAL CONTRACTOR TO CONFIRM LIGHT FIXTURE CATALOG NUMBERS WITH ALL LIGHT FIXTURES SPECIFIED ON PLANS FOR FIXTURE TRIMS, VOLTAGES, LAMPS ETC.
- ELECTRICAL CONTRACTOR TO CONFIRM LOCATIONS OF ALL ELECTRICAL DEVICES WITH FIXTURES LOCATIONS PRIOR TO ROUGH-IN.
- ELECTRICAL CONTRACTOR TO VERIFY ALL EQUIPMENT ELECTRICAL CHARACTERISTICS PRIOR TO ROUGH-IN.
- ELECTRICAL CONTRACTOR TO VISIT SITE AND VERIFY ALL EXISTING CONDITIONS PRIOR TO BID.
- FIRE STOP ALL PENETRATIONS IN RATED ASSEMBLIES.
- ELECTRICAL CONTRACTOR SHALL REVIEW ALL OTHER TRADES DRAWINGS AND/OR COORDINATE WITH OTHER TRADES AND VERIFY IF THERE ARE ANY ADDITIONAL ELECTRICAL REQUIREMENTS NOT SHOWN ON ELECTRICAL DRAWINGS. COST FOR WORK SHOWN ON OTHER TRADES DRAWINGS SHALL BE INCLUDED IN BASE BID. WIRE ALL MISCELLANEOUS CONTROLS AS REQUIRED TO PROVIDE A COMPLETE SYSTEM.
- ALL DEVICES IN OR ABOVE COUNTERS OR VANITIES SHALL HAVE LOCATIONS AND MOUNTING HEIGHTS CONFIRMED WITH ARCHITECT'S ELEVATIONS AND SECTIONS. ANY ADJUSTMENTS TO MOUNTING HEIGHTS REQUIRED BY LACK OF COORDINATION WILL BE AT CONTRACTOR'S EXPENSE.
- ALL NEW CONDUIT ROUTING SHALL BE RUN CONCEALED IN ALL FINISHED AREAS. EXPOSED CONDUIT RINGS ARE ONLY PERMITTED IN ELEVATOR ROOMS OR ON BRICK WALLS WHERE NOTED ON PLANS. PATCH ALL CONDUITS TO MATCH ADJACENT WALL SURFACES. CONFIRM ROUTING IN FIELD WITH OWNER/ARCHITECT IN ALL AREAS PRIOR TO ROUGH-IN. TYPE MC CABLE WITH LISTED FITTINGS (AS APPROVED BY LOCAL JURISDICTION) SHALL BE PERMITTED IN CONCEALED WORK IN WALLS, FLOORS & CEILING. WHERE FINISHING CABLES IS NOT POSSIBLE AT EXISTING BUILDING CONSTRUCTION, E.G. SHALL SAWCUT WALLS AND CHANNEL OR SAWCUT BRICKS OR BLOCKS AND REMOVE THEM FOR RACKING. INSTALLATION: REPLACE BRICK OR BLOCK FACE AND MORTAR AROUND THEM WITH MATCHING MORTAR OR PATCH GANNELED WALLS WITH PLASTER FOR A FINISHED SURFACE. CONFIRM ALL LOCATIONS WITH OWNER AND ARCHITECT PRIOR TO ANY SAWCUTTING OF EXISTING CONSTRUCTION.
- ALL POWER WIRING IN EXPOSED CONSTRUCTION IS TO BE IN EMT CONDUIT WITH STEEL SET SCREWS OR COMPRESSION FITTINGS. MC CABLE MAY ONLY BE USED WHERE CONCEALED.

COMMISSIONING NOTE:

- GENERAL CONTRACTOR SHALL PROVIDE COMMISSIONING OF THE LIGHTING SYSTEM AS REQUIRED BY AHJ AND PER THE 2021 MICHIGAN COMMERCIAL ENERGY CODE, C408. COMMISSIONING SHALL BE COMPLETED BY A CITY APPROVED COMMISSIONING AGENCY. GENERAL AND ELECTRICAL CONTRACTORS SHALL COORDINATE ALL COMMISSIONING REQUIREMENTS WITH COMMISSIONING AGENT.
- COMMISSIONING AGENT SHALL DEVELOP A COMMISSIONING PLAN.
 - PRELIMINARY COMMISSIONING REPORT SHALL BE PROVIDED TO OWNER AND MADE AVAILABLE TO THE LOCAL CODE OFFICIAL UPON REQUEST.
 - WITHIN 90 DAYS OF RECEIPT OF CERTIFICATE OF OCCUPANCY, COMMISSIONING AGENT SHALL PROVIDE TO THE BUILDING OWNER A FINAL COMMISSIONING REPORT INDICATING THE INSTALLED LIGHTING IS COMPLIANT AND DOCUMENTATION OF LIGHTING, INCLUDING CONTROLS AND SET POINTS. GENERAL CONTRACTOR SHALL PROVIDE COMMISSIONING AGENT WITH THE FOLLOWING:
 - SUBMITTALS, INCLUDING ALL SELECTED OPTIONS FOR ALL LIGHTING AND LIGHTING CONTROLS.
 - MANUFACTURER OPERATION MANUALS FOR ALL LIGHTING.
 - MANUFACTURER MAINTENANCE MANUALS FOR ALL LIGHTING.
 - MANUFACTURER RECOMMENDED SCHEDULE FOR INSPECTION AND RECALIBRATION OF LIGHTING CONTROLS.
 - A NARRATIVE FOR HOW EACH SYSTEM IS INTENDED TO OPERATE INCLUDING SET POINTS.
 - LIGHTING SHALL BE TESTED FOR FUNCTIONAL PERFORMANCE. GENERAL CONTRACTOR SHALL PROVIDE REPRESENTATIVES WITH EXPERTISE TO PARTICIPATE AND ASSIST THE COMMISSIONING AGENT IN THE TESTING OF LIGHTING.

SYMBOLS (NOT ALL SYMBOLS MAY BE USED)

\$	20A-120/277V SINGLE POLE TOGGLE SWITCH, HUBBELL, TYPE C5B120xx
\$3	20A-120/277V THREE WAY TOGGLE SWITCH, HUBBELL, TYPE C5B320xx
\$4	20A-120/277V FOUR WAY TOGGLE SWITCH, HUBBELL, TYPE C5B420xx
\$T	20A-300V MANUAL STARTING SWITCH IV THERMAL OVERLOAD RELAY- IF NOT INTEGRAL TO MOTOR - FLUSH MOUNTED IN WALL AND SURFACE MOUNTED AT EQUIPMENT ROOMS WITH PADLOCK LOCK-OUT COVER, SQUARE D (CLASS 35) OR APPROVED
\$M	MANUAL TOGGLE CONTROLLER/DISCONNECT WITH SURFACE ENCLOSURE AND COVER WITH PADLOCK HASP. PROVIDE AMPS, POLES AND VOLTAGE TO MATCH EQUIPMENT. HUBBELL, TBMX SERIES
\$VS	120/277V INFRARED WALL SWITCH VACUANCY SENSOR - NASTSTOPPER #FN-301. SENSORS SHALL BE SET TO OPERATE AS VACUANCY SENSORS - AUTOMATIC OFF AFTER 30 MINUTES, MANUAL ON ONLY.
\$VD	120/277V INFRARED WALL SWITCH OCCUPANCY SENSOR WITH 0-10V DIMMING CONTROL - NASTSTOPPER #FN-311. SENSORS SHALL BE SET TO OPERATE AS VACUANCY SENSORS - AUTOMATIC OFF AFTER 30 MINUTES, MANUAL ON ONLY.
\$DO	LOW VOLTAGE DIGITAL ON/OFF SWITCH, SEE LIGHTING CONTROL DETAILS. FINISH SELECTED BY ARCHITECT.
\$DD	LOW VOLTAGE DIGITAL DIMMING AND ON/OFF SWITCH, SEE LIGHTING CONTROL DETAILS. FINISH SELECTED BY ARCHITECT.
\$DC	LOW VOLTAGE DIGITAL TOUCHSCREEN CONTROLLER, SEE LIGHTING CONTROL DETAILS. FINISH SELECTED BY ARCHITECT.
\$O	LOW VOLTAGE DIGITAL ON/OFF 2 BUTTON SWITCH FOR OVERRIDE CONTROL OF LIGHTING CONTROL SYSTEM, SEE LIGHTING CONTROL DETAILS. FINISH SELECTED BY ARCHITECT.
RCD	DIGITAL ROOM CONTROLLER WITH DIMMING CAPABILITY - SEE LIGHTING CONTROL DETAILS.
DOS	DIGITAL INFRARED CEILING VACUANCY/OCCUPANCY SENSOR - SEE LIGHTING CONTROL DETAILS.
DPG	DIGITAL INTERIOR PHOTOCELL UNIT FOR DAYLIGHT HARVESTING - SEE LIGHTING CONTROL DETAILS.
Ⓜ	20A-125 V SINGLE RECEPTACLE, HUBBELL, TYPE 59361x
Ⓜ	20A-125 V DUPLEX RECEPTACLE, HUBBELL, TYPE 59362x
Ⓜ	20A-125 V DUPLEX WITH INTEGRAL "GFCI" PROTECTION, SELF-TEST, WEATHER-RESISTANT, AND TAMPER RESISTANT, HUBBELL, TYPE 57536256x
Ⓜ	SAME AS Ⓜ OR Ⓜ EXCEPT MOUNTED ABOVE COUNTER, CONFIRM EXACT HEIGHT
Ⓜ	SAME AS Ⓜ OR Ⓜ EXCEPT 2 MOUNTED IN 2 GANG BOX WITH SINGLE COVER PLATE.
Ⓜ	SAME AS Ⓜ OR Ⓜ EXCEPT THE DEVICE SHALL BE SPLIT W/REED FOR SWITCHING CONTROL OF DEVICE. TOP RECEPTACLE(S) SHALL BE UNCONTROLLED, BOTTOM RECEPTACLE SHALL BE CONTROLLED. RECEPTACLE TO BE PERMANENTLY MARKED AS CONTROLLED PER THE NEG. HUBBELL, TYPE BR2021x
Ⓜ	20A-125 V WEATHER RESISTANT DUPLEX WITH INTEGRAL GFCI PROTECTION AND WEATHERPROOF SINGLE W/WHILE IN USE RACK COVER, HUBBELL 57536256x AND M4420C
Ⓜ	RECEPTACLE MODIFIERS: W/P = WEATHERPROOF (WHILE-IN-USE) IG = ISOLATED GROUND GFI = INTEGRAL "GFI" PROTECTION V = 20A-125 V DUPLEX RECEPTACLE WITH INTEGRAL TRANSFORMER AND (2) SA USB PORTS, HUBBELL, TYPE USB20AS TR = 20A-125 V DUPLEX TAMPER RESISTANT, HUBBELL, TYPE HUB5362TRx TV = FOR TELEVISION, REFERENCE A/V SHOP DRAWINGS OR ARCHITECTURAL ELEVATIONS FOR MOUNTING HEIGHT. 1" = MOUNT 1" INCHES ABOVE FINISHED FLOOR.
Ⓜ	SPECIAL PURPOSE 1-PHASE RECEPTACLE, NEMA CONFIGURATION AS NOTED.
Ⓜ	SPECIAL PURPOSE 3-PHASE RECEPTACLE, NEMA CONFIGURATION AS NOTED.
Ⓜ	SAME AS Ⓜ ONLY RECESSED MOUNTED IN CEILING
Ⓜ	FLUSH CAST IRON FLOOR BOX WITH 1 1/2" CONDUIT ACCESS FOR LOW VOLTAGE AND 1" CONDUIT ACCESS FOR POWER, HUBBELL #51CFB - VERIFY FLOOR BOX SIZE WITH SLAB DEPTH. PROVIDE UNIVERSAL CARPET FLANGE AND COVER ASSEMBLY, FINISH AS SELECTED BY ARCHITECT - #51CF0xx OR PROVIDE UNIVERSAL TILE FLANGE AND COVER ASSEMBLY, FINISH AS SELECTED BY ARCHITECT - #51TF0xx. PROVIDE SYSTEM-ONE SUB-PLATE COMBINATION AS REQUIRED WITH UP TO SIX (6) DATA JACKS PLUS ONE (1) DUPLEX RECEPTACLE OR FOUR (4) DATA JACKS PLUS TWO (2) DUPLEX RECEPTACLES. CONFIRM DEVICE LAYOUT WITH ENGINEER, PRIOR TO ORDERING.
Ⓜ	POWER HUB AND ASSOCIATED DEVICES AS REQUIRED - INCLUDING HUBCAP, RECEPTACLE DEVICE WITH QUAD RECEPTACLE W/RED TO 1-CIRCUIT, HARDWARE DEVICE (FOR FURNITURE BASE FEED), OR DATA DEVICE WITH UP TO EIGHT KEYSTONE MODULES). CONFIRM DEVICE LAYOUT WITH LOCAL LEGRAND/CONNECTAC VENDOR (W/REMODEL OR APPROVED EQUAL), OWNER AND FURNITURE VENDOR, PRIOR TO ORDERING.
Ⓜ	2" SQUARE POWER POLE WITH DIVIDER, HEIGHT AS REQUIRED BY CEILING HEIGHT. FINISH BY ARCHITECT. PROVIDE DEVICES OR FURNITURE/EQUIPMENT FEEDS AS NOTED ON PLANS.
Ⓜ	STANDARD JUNCTION BOX SIZE PER N.E.C. AND SUPPORTED INDEPENDENT OF CONDUIT SYSTEM
Ⓜ	HEAVY-DUTY 3 POLE FUSIBLE DISCONNECT SWITCH W/FUSETRONS SIZED AS NOTED OR AT 125% OF ACTUAL MOTOR NAMEPLATE RATING-SWITCH SIZE AS NOTED
Ⓜ	XXXXXX = DISCONNECT SIZE / FUSE SIZE OR NF = NON-FUSED / NEMA ENCLOSURE
Ⓜ	120/208V - 3 PHASE - 4 WIRE ELECTRICAL BRANCH CIRCUIT PANEL
Ⓜ	277/480V - 3 PHASE - 4 WIRE ELECTRICAL BRANCH CIRCUIT PANEL
Ⓜ	4" 5G x 2-1/8" DEEP BOX WITH PLASTER RING TO MATCH DEVICE FOR TELEPHONE AND/OR DATA OUTLET - 5/8" 3/4" CONDUIT INTO ACCESSIBLE CEILING SPACE. PROVIDE BLANK COVER IF NOT USED BY OWNER. TV = FOR TELEVISION, REFERENCE A/V SHOP DRAWINGS OR ARCHITECTURAL ELEVATIONS FOR MOUNTING HEIGHT
Ⓜ	TWO-WAY COMMUNICATION EMERGENCY PHONE - REFER TO DRAWINGS FOR DETAILS.
Ⓜ	PREFERRED UNIT CONTROL PANEL-CONNECT AND WIRE PER MFRS. WIRING DIAGRAMS. PROVIDE DISCONNECT SWITCH AS REQUIRED BY N.E.C.
Ⓜ	MOTOR CONNECTION AS NOTED-CONNECT WITH FLEXIBLE OR SEALTIGHT CONDUIT
Ⓜ	THERMOSTAT/TEMPERATURE SENSOR CONNECTION, PROVIDED BY OTHERS, WIRE & INSTALLED BY E.C.
Ⓜ	CONDUIT RUN EXPOSED, OVERHEAD, CONCEALED ABOVE CEILING OR IN WALL. CROSSHATCHES DENOTE NUMBER OF # 12 AWG COPPER CONDUCTORS UNLESS NOTED OTHERWISE. IF NO CONDUCTORS ARE SHOWN PROVIDE 2 #12 & GND. MINIMUM OR AS REQUIRED
Ⓜ	CONDUIT RUN IN OR BELOW FLOOR SLABS - MAINTAIN 2" MINIMUM CONCRETE COVER ABOVE CONDUIT - CROSSHATCHES DENOTE NUMBER OF #12 AWG COPPER CONDUCTORS UNLESS NOTED OTHERWISE. IF NO CONDUCTORS ARE SHOWN PROVIDE 2 #12 & GND. MINIMUM OR AS REQUIRED
Ⓜ	ELECTRIC STRIKE ROUGH-IN - WITH 3/4" CONDUIT INTO ACCESSIBLE CEILING SPACE AS REQUIRED. DRILL HOLE IN DOOR FRAME AS REQUIRED. REFER TO ACCESS CONTROL ROUGH-IN DIAGRAM ON DRAWING E501.
Ⓜ	ADA DOOR OPERATOR ACTUATOR ROUGH-IN - REFER TO DRAWINGS FOR DETAILS.
Ⓜ	CELLING MTD, WIRELESS ACCESS POINT ROUGH-IN - WITH 3/4" CONDUIT INTO ACCESSIBLE CEILING SPACE AS REQUIRED.
Ⓜ	CARD READER ROUGH-IN - WITH 3/4" CONDUIT INTO ACCESSIBLE CEILING SPACE AS REQUIRED. DRILL HOLE IN DOOR FRAME AS REQUIRED. REFER TO ACCESS CONTROL ROUGH-IN DIAGRAM ON DRAWING E501.
Ⓜ	CCTV CAMERA ROUGH-IN - WITH 3/4" CONDUIT INTO ACCESSIBLE CEILING SPACE AS REQUIRED.
Ⓜ	CONTRACTOR - AMPACITY AND POLES AS NOTED WITH NEMA 1 ENCLOSURE
Ⓜ	FURNITURE FEED FOR POWER FROM WALL TO PARTITION. MAKE CONNECTION TO TERMINAL BLOCK. PROVIDE FLEXIBLE CONNECTION TO PARTITION.
Ⓜ	SAME AS Ⓜ ONLY FOR DATA CABLE-SIZE AS NOTED

FIRE ALARM SYMBOLS (NOT ALL SYMBOLS MAY BE USED)

F	FIRE ALARM SYSTEM MANUAL PULL STATION, FLUSH MOUNTED
Ⓜ	FIRE ALARM AND EMERGENCY COMMUNICATION SYSTEM SPEAKER WITH ADA STROBE, FLUSH WALL MOUNTED. cd = CANDELA RATING
Ⓜ	FIRE ALARM ADA STROBE LIGHT WITH LENS, FLUSH MOUNTED. cd = CANDELA RATING
Ⓜ	FIRE ALARM AND EMERGENCY COMMUNICATION SYSTEM SPEAKER WITH ADA STROBE, CEILING MOUNTED. cd = CANDELA RATING
Ⓜ	FIRE ALARM ADA STROBE LIGHT WITH LENS, CEILING MOUNTED. cd = CANDELA RATING
Ⓜ	WALL MOUNTED EMERGENCY COMMUNICATION SYSTEM SPEAKER ONLY
Ⓜ	CELLING MOUNTED EMERGENCY COMMUNICATION SYSTEM SPEAKER ONLY
Ⓜ	ADDRESSABLE FIRE ALARM SYSTEM SMOKE DETECTOR. (E = ELEVATOR RECALL)
Ⓜ	ADDRESSABLE FIRE ALARM SYSTEM HEAT DETECTOR
Ⓜ	FIRE ALARM SYSTEM CONTROL PANEL / EMERGENCY COMMUNICATION SYSTEM CONTROL PANEL
Ⓜ	FIRE ALARM SYSTEM ANNUNCIATOR PANEL
Ⓜ	SIGNAL EXPANDER PANEL AND AMPLIFIER
Ⓜ	DUCT SMOKE DETECTOR WITH REMOTE KEY TEST SWITCH [K] - MONITORED BY FACP
Ⓜ	SPRINKLER SYSTEM FLOW SWITCH
Ⓜ	SPRINKLER SYSTEM TAMPER SWITCH
Ⓜ	FIRE ALARM SYSTEM CONTROL MODULE
Ⓜ	FIRE ALARM SYSTEM MONITORING MODULE
Ⓜ	FIRE ALARM SYSTEM DOOR HOLD OPEN DEVICE
Ⓜ	FIRE ALARM SYSTEM KNOX BOX - CONFIRM TYPE WITH LOCAL FIRE MARSHAL

- SYMBOL LEGEND GENERAL NOTES:**
- ALL TOGGLE SWITCHES ARE TO BE FLUSH MOUNTED AND BE PROVIDED WITH A STAINLESS STEEL COVER PLATE TO MATCH DEVICE UNLESS OTHERWISE SPECIFIED. COLOR OF DEVICE TO BE SELECTED BY ARCHITECT. COMPLY WITH CURRENT ADA REQUIREMENTS.
 - ALL RECEPTACLES, TELEPHONE, ETC. ARE TO BE FLUSH MOUNTED AND BE PROVIDED WITH A STAINLESS STEEL COVER PLATE TO MATCH THE DEVICE UNLESS OTHERWISE SPECIFIED. COLOR OF THE DEVICE TO BE SELECTED BY ARCHITECT. ALL BACK-TO-BACK DEVICES TO BE OFFSET HORIZONTALLY 6" MINIMUM. COMPLY WITH CURRENT ADA REQUIREMENTS.
 - THE EXACT LOCATION AND MOUNTING HEIGHT OF ALL SWITCHES, OUTLETS, ETC. ARE TO BE CONFIRMED WITH ARCHITECTURAL ELEVATIONS AND OWNER PRIOR TO ROUGH-IN. IF LOCATIONS AND MOUNTING HEIGHTS ARE NOT SHOWN, REQUEST LOCATIONS PRIOR TO ROUGH-IN. CONFIRM EQUIPMENT OUTLET LOCATIONS WITH EQUIPMENT REQUIREMENTS. COMPLY WITH A.D.A. REQUIREMENTS.
 - SWITCHES AND DEVICES TO BE AS SPECIFIED LEVITON, OR P # 3 AS ACCEPTABLE ALTERNATES FOR SPECIFICATION GRADES.
 - NO ITEMS ARE TO BE SCALED OFF THE ELECTRICAL DRAWINGS. ALL DIMENSIONS SHOWN MUST BE VERIFIED WITH THE OWNER PRIOR TO ROUGH-IN.

McHenry & Associates Incorporated
Mc&A
 Consulting Engineers est. 1960
 25001 Emery Road, Suite #200
 Warrensville Heights, Ohio 44128
 Phone: 216-292-4696
 Fax: 216-292-5874
 Email: mail@mcHenryassociates.com

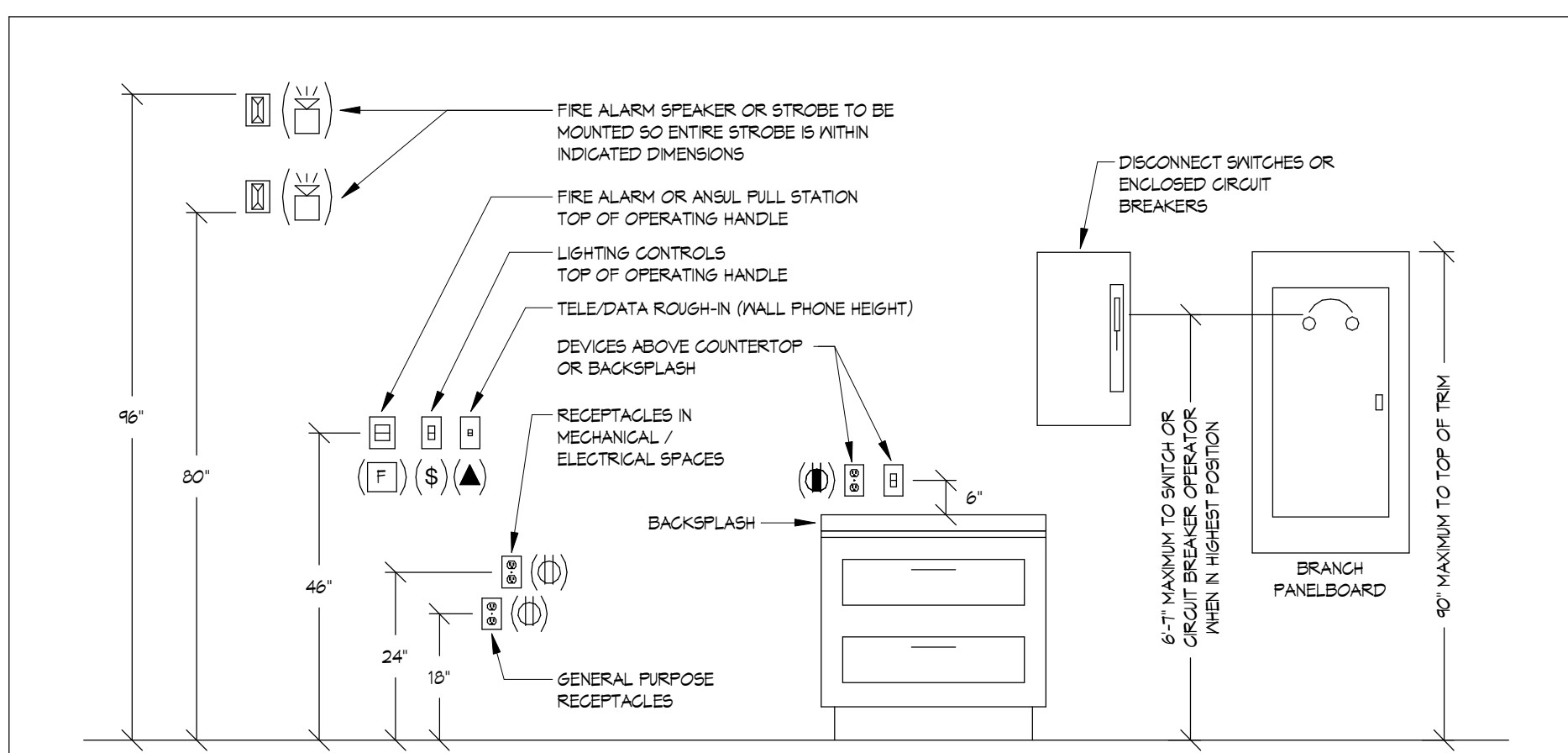
City of Kalamazoo - Crosstown Facility
 CPED & KDPS Workplace Renovation
 150 E Crosstown Parkway Kalamazoo MI 49001

Seal:

BID Set 08/21/2025
 © 2025, intersect studio, llc
 Project Number: 23-046

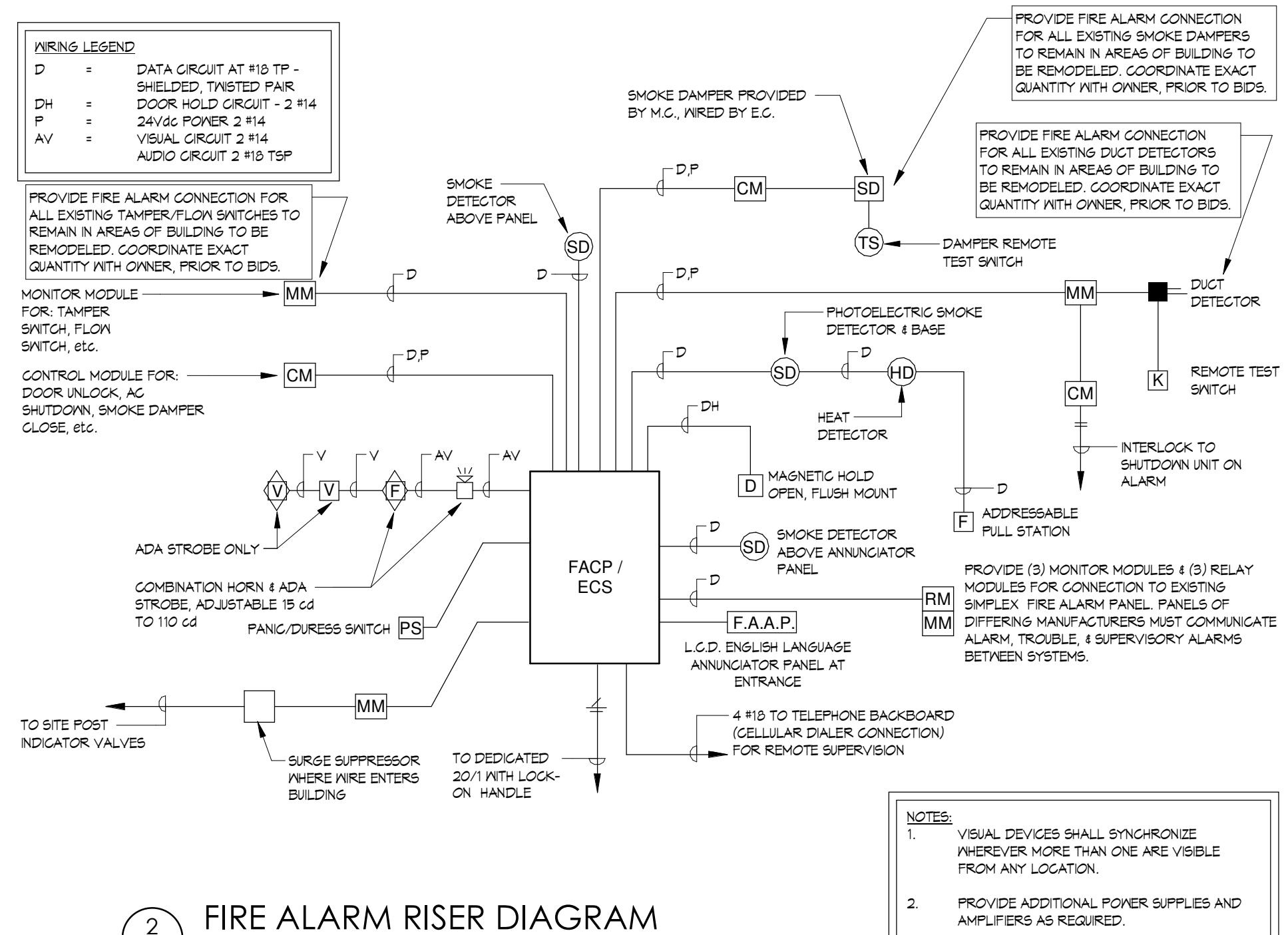
ELECTRICAL LEGENDS & GENERAL NOTES

E001



- NOTES:**
- THE EXACT LOCATION AND MOUNTING HEIGHT OF ALL SWITCHES, OUTLETS, ETC. ARE TO BE CONFIRMED WITH ARCHITECTURAL ELEVATIONS AND OWNER PRIOR TO ROUGH-IN. IF LOCATIONS AND MOUNTING HEIGHTS ARE NOT SHOWN, REQUEST LOCATIONS PRIOR TO ROUGH-IN. CONFIRM EQUIPMENT OUTLET LOCATIONS WITH EQUIPMENT REQUIREMENTS. COMPLY WITH A.D.A. REQUIREMENTS.
 - ALL MOUNTING HEIGHTS MUST COMPLY WITH ADA STANDARDS.

TYPICAL WALL EQUIPMENT AND DEVICE MOUNTING HEIGHT DETAIL
 NO SCALE



- NOTES:**
- ELECTRICAL CONTRACTOR SHALL VERIFY EXACT WIRING WITH MANUFACTURER'S WIRING DIAGRAMS PRIOR TO INSTALLATION.
 - ALL DEVICES TO BE FIELD TESTED WITH WRITTEN CERTIFICATION OF SYSTEM. PERFORM ALL TESTS IN THE PRESENCE OF THE AUTHORITY HAVING JURISDICTION.
 - PROVIDE CONNECTION TO REMOTE SUPERVISION AS DIRECTED FOR SUPERVISION OF SYSTEM IN COMPLIANCE WITH LOCAL AUTHORITY AND OWNER. PROVIDE ALL INTERFACE REQUIRED TO INITIATE REMOTE SUPERVISION. MONITORING SERVICE WILL BE PAID FOR BY THE OWNER.
 - FLOIN SWITCHES SHALL BE PROVIDED BY THE FIRE PROTECTION CONTRACTOR AND WIRED BY THE E.C. PROVIDE MODULE INTERFACE.
 - TAMPER SWITCH WILL BE FURNISHED WITH SHUT-OFF VALVE BY THE FIRE PROTECTION CONTRACTOR AND BE WIRED BY THE E.C. PROVIDE INTERFACE MODULES AT TAMPER SWITCH.
 - DUCT SMOKE DETECTORS ARE TO BE FURNISHED AND INSTALLED BY THE FIRE ALARM CONTRACTOR PER MFR'S INSTALLATION REQUIREMENTS AND NFPA 72E. PROVIDE (REMOTE TEST SWITCHES) MONITORING SYSTEM CONNECTION.
 - INDICATION DEVICE SHALL BE COMBINATION SPEAKER HORN (EDT) / STROBE, FIELD ADJUSTABLE, 15 cd TO 110 cd. ALL STROBES SHALL SYNCHRONIZE. SPEAKERS SHALL HAVE MULTIPLE TAPS. ADJUST SYSTEM AT COMPLETION OF CONSTRUCTION TO REQUIRED SOUND PRESSURE LEVELS AND INTELLIBILITY.
 - FIRE ALARM PANEL SHALL BE SOLID STATE, ADDRESSABLE, ANALOG PANEL WITH CLASS "B" BELL CIRCUIT, ALARM AND TROUBLE INDICATION BY DEVICE, 24 HOUR BATTERY BACKUP AND PANEL STATUS INDICATION LIGHTS INCLUDING VOICE EVACUATION FUNCTIONS PER NFPA 72.
 - SYSTEM SHALL BE SUPPLIED BY ONE MFR. AND BE BY: EST, FCI, GUARDIAN, INCLUDING, GANEXELL, SILENT KNIGHT OR APPROVED EQUAL.
 - THE ENTIRE SYSTEM SHALL COMPLY WITH ALL APPLICABLE CODES AND LISTINGS, INCLUDING THE NFPA 72, UL, FM AND THE STATE AND LOCAL FIRE MARSHALL.
 - FIRE ALARM SYSTEM MANUFACTURER SHALL PROVIDE ALL SUBMITTALS REQUIRED BY LOCAL OFFICIALS FOR PERMIT INCLUDING, BUT NOT LIMITED TO, BATTERY CALCULATIONS, VOLTAGE DROP CALCULATIONS, COT SHEETS, DRAWINGS ETC. PAY ALL PERMIT FEES, ETC. PROVIDE SHOP DRAWINGS WITH REQUIRED DESIGN PROFESSIONAL SEAL.
 - FIRE ALARM CONTROL PANEL SHALL BE EXPANDABLE FOR THE QUANTITY OF ADDRESSABLE INPUT AND OUTPUT POINTS NECESSARY FOR THIS ENTIRE FACILITY ONCE IT IS COMPLETELY OCCUPIED. POINTS QUANTITY ESTIMATE SHALL BE BASED ON THE FACILITY USE, HVAC SYSTEM TYPE, FIRE PROTECTION ZONING AND LOCAL CODE REQUIREMENTS. INCLUDE THIS INFORMATION WITH THE PROJECT SUBMITTAL DATA.
 - SEE ELEVATOR SYSTEM WIRING DIAGRAM FOR ADDITIONAL REQUIREMENTS.

- NOTES:**
- VISUAL DEVICES SHALL SYNCHRONIZE WHEREVER MORE THAN ONE ARE VISIBLE FROM ANY LOCATION.
 - PROVIDE ADDITIONAL POWER SUPPLIES AND AMPLIFIERS AS REQUIRED.

FIRE ALARM RISER DIAGRAM
 NO SCALE

GENERAL DEMOLITION NOTES:

- A. THIS CONTRACTOR SHALL PERFORM ALL DEMOLITION OF EXISTING ELECTRICAL SYSTEMS AS INDICATED ON ELECTRICAL AND ARCHITECTURAL PLANS OR AS NECESSARY FOR THE PROJECT. REMOVE FROM SITE AND PROPERLY DISPOSE OF ALL MATERIAL AND DEBRIS FROM THIS WORK.
- B. DEMOLITION DRAWINGS ARE GENERAL IN NATURE SHOWING THE SCOPE OF DEMOLITION WORK. CONTRACTOR SHALL VISIT THE SITE AND BECOME FAMILIAR WITH THE QUANTITY OF LIGHT FIXTURES, OUTLETS, ETC. REMOVE ALL EQUIPMENT AND DEVICES NO LONGER REQUIRED FOR FINISHED CONSTRUCTION. ALL EXISTING LIGHTS, CONDUIT, WIRE AND DEVICES IN PROJECT AREAS SHALL BE REMOVED AND DISPOSED OF. REMOVE CONDUITS BEYOND NEW SURFACES. REMOVE ALL EXISTING WIRE FROM CONDUIT BACK TO POINT OF COMMON USE OR TO PANELS. LABEL EXISTING CIRCUIT BREAKERS "SPARE" IF NOT REUSED FOR NEW WORK.
- C. DISCONNECT EXISTING EQUIPMENT IN BUILDING THAT IS TO BE REMOVED UNDER OTHER SECTIONS. REMOVE DATA AND PHONE CABLING SYSTEM AS DIRECTED BY OWNER. NO CABLES SHALL BE REMOVED OR CUT WITHOUT APPROVAL FROM OWNER. ANY EXISTING CABLES TO REMAIN SHALL BE SUPPORTED FROM STRUCTURE BEFORE CELLS REMOVAL.
- D. PATCH ALL SURFACES TO MATCH SURROUNDINGS FOR DEVICES TO BE REMOVED FROM EXISTING WALLS TO BE MAINTAINED. EXISTING ROUGH-IN BOXES IN WALL TO REMAIN MAY BE REUSED IF CODE COMPLIANT AND APPROVED FOR LOCATION BY ARCHITECT.
- E. THE OWNER RESERVES THE RIGHT OF SALVAGE FOR ALL EXISTING ELECTRICAL EQUIPMENT PRIOR TO DEMOLITION. THE CONTRACTOR SHALL REVIEW ALL MATERIALS AND DELIVER TO THE OWNER THOSE REQUIRED IN THEIR EXISTING CONDITION. ALL OTHER MATERIAL SHALL BE REMOVED BY THIS CONTRACTOR.
- F. ALL CIRCUITS WHICH ARE REQUIRED TO REMAIN ACTIVE SHALL BE MAINTAINED OR REWORKED AS REQUIRED. ANY EXISTING CIRCUITS OR CABLING SYSTEMS SERVING AREAS NOT AFFECTED BY DEMOLITION SHALL BE MAINTAINED. ALL CIRCUITS SHALL BE VERIFIED WITH EXISTING DRAWINGS AND ACTUAL FIELD CONDITIONS PRIOR TO BEGINNING DEMOLITION.
- G. PHASING: CONTRACTOR IS REQUIRED TO COORDINATE THE REMOVAL AND/OR SHUTDOWN OF ANY EXISTING SYSTEMS AND ANY RELATED MECHANICAL, PLUMBING OR FIRE PROTECTION SYSTEMS REQUIRED FOR THIS PROJECT TO MAINTAIN THE EXISTING BUILDING OPERATIONS THROUGHOUT THE COURSE OF CONSTRUCTION. CONFORM TO THE PROJECT CONSTRUCTION SCHEDULE PHASING SEQUENCE AND INTENT IDENTIFIED BY THE CONSTRUCTION MANAGER AND ARCHITECT. CONTRACTOR SHALL COORDINATE ALLOWABLE WORKING HOURS IN SPECIFIC AREAS OF THE EXISTING BUILDING WITH THE CONSTRUCTION MANAGER. IF AFTER HOURS WORK IS REQUIRED, PREMIUM TIME SHALL BE INCLUDED IN BID. ANY REQUIRED DEMOLITION, RELOCATION OR SHUTDOWN OF EXISTING SYSTEMS SHALL BE SUBMITTED FOR APPROVAL A MINIMUM OF TWO (2) WEEKS PRIOR TO PERFORMING THE REQUIRED WORK. NO DEMOLITION WORK AFFECTING EXISTING SYSTEMS TO REMAIN SHALL BE PERFORMED WITHOUT APPROVAL FROM THE CONSTRUCTION MANAGER. INCLUDE ANY TEMPORARY FACILITIES REQUIRED TO MAINTAIN EXISTING SYSTEMS IN OPERATION DURING THE COURSE OF DEMOLITION WORK IN BID.

CODED NOTES

- ① ALL LIGHTING FIXTURES, DEVICES AND CONTROLS IN THIS AREA SHALL BE MADE SAFE FOR DEMOLITION UNLESS NOTED OTHERWISE - 'XR'. ELECTRICAL DEMOLITION SHALL BE PERFORMED PER THE GENERAL DEMOLITION NOTES. REMOVE ALL WIRING, CONDUIT, BOXES, ETC. ASSOCIATED WITH THE FIXTURES AND DEVICES BACK TO THEIR SOURCE OR NEAREST POINT OF COMMON USE. MAINTAIN ALL POWER, DATA WIRING AND CONDUIT RUNNING THROUGH THIS SPACE THAT FEEDS EXISTING SPACES TO REMAIN OR THAT IS TO BE REUSED OR MODIFIED UNDER THE NEW WORK SCOPE. IDENTIFY THIS CONDUIT AND WIRING TO PREVENT DAMAGE DURING DEMOLITION. THE EXACT EXTENT OF DEMOLITION AREA SHOULD BE CONFIRMED WITH THE ARCHITECTURAL DEMOLITION DRAWINGS.
- ② MAINTAIN ALL LIGHTING FIXTURES, DEVICES AND CONTROLS WITHIN THIS SPACE - 'X'.



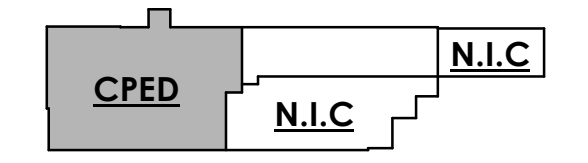
McHenry & Associates Incorporated
Mc&A
 Consulting Engineers est. 1960
 25001 Emery Road, Suite #200
 Warrensville Heights, Ohio 44128
 Phone: 216-292-4696
 Fax: 216-292-5874
 Email: mail@mcHenryassociates.com

City of Kalamazoo - Crosstown Facility
 CPED & KDPS Workplace Renovation
 150 E Crosstown Parkway Kalamazoo MI 49001

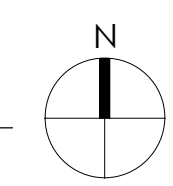
Seal:

BID Set 08/21/2025
 © 2025, intersect studio, llc
 Project Number: 23-046

LIGHTING DEMO PLAN - MAIN LEVEL CPED



① MAIN LEVEL LIGHTING DEMO PLAN - CPED
 1/8" = 1'-0"



○ KEY PLAN - CPED
 NTS

ED100

GENERAL DEMOLITION NOTES:

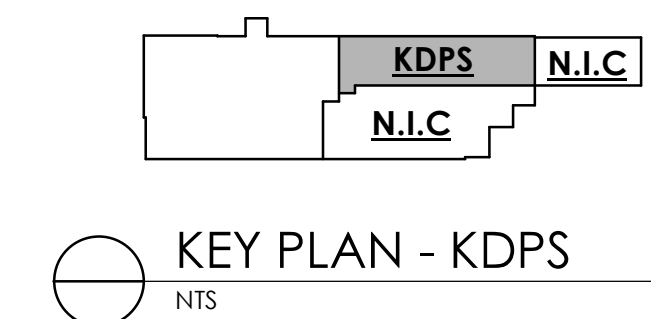
- A. THIS CONTRACTOR SHALL PERFORM ALL DEMOLITION OF EXISTING ELECTRICAL SYSTEMS AS INDICATED ON ELECTRICAL AND ARCHITECTURAL PLANS OR AS NECESSARY FOR THE PROJECT. REMOVE FROM SITE AND PROPERLY DISPOSE OF ALL MATERIAL AND DEBRIS FROM THIS WORK.
- B. DEMOLITION DRAWINGS ARE GENERAL IN NATURE SHOWING THE SCOPE OF DEMOLITION WORK. CONTRACTOR SHALL VISIT THE SITE AND BECOME FAMILIAR WITH THE QUANTITY OF LIGHT FIXTURES, OUTLETS, ETC. REMOVE ALL EQUIPMENT AND DEVICES NO LONGER REQUIRED FOR FINISHED CONSTRUCTION. ALL EXISTING LIGHTS, CONDUIT, WIRE AND DEVICES IN PROJECT AREAS SHALL BE REMOVED AND DISPOSED OF. REMOVE CONDUITS BEYOND NEW SURFACES. REMOVE ALL EXISTING WIRE FROM CONDUIT BACK TO POINT OF COMMON USE OR TO PANELS. LABEL EXISTING CIRCUIT BREAKERS "SPARE" IF NOT REUSED FOR NEW WORK.
- C. DISCONNECT EXISTING EQUIPMENT IN BUILDING THAT IS TO BE REMOVED UNDER OTHER SECTIONS. REMOVE DATA AND PHONE CABLING SYSTEM AS DIRECTED BY OWNER. NO CABLES SHALL BE REMOVED OR CUT WITHOUT APPROVAL FROM OWNER. ANY EXISTING CABLES TO REMAIN SHALL BE SUPPORTED FROM STRUCTURE BEFORE CEILING REMOVAL.
- D. PATCH ALL SURFACES TO MATCH SURROUNDINGS FOR DEVICES TO BE REMOVED FROM EXISTING WALLS TO BE MAINTAINED. EXISTING ROUGH-IN BOXES IN WALL TO REMAIN MAY BE REUSED IF CODE COMPLIANT AND APPROVED FOR LOCATION BY ARCHITECT.
- E. THE OWNER RESERVES THE RIGHT OF SALVAGE FOR ALL EXISTING ELECTRICAL EQUIPMENT PRIOR TO DEMOLITION. THE CONTRACTOR SHALL REVIEW ALL MATERIALS AND DELIVER TO THE OWNER THOSE REQUIRED IN THEIR EXISTING CONDITION. ALL OTHER MATERIAL SHALL BE REMOVED BY THIS CONTRACTOR.
- F. ALL CIRCUITS WHICH ARE REQUIRED TO REMAIN ACTIVE SHALL BE MAINTAINED OR REWORKED AS REQUIRED. ANY EXISTING CIRCUITS OR CABLING SYSTEMS SERVING AREAS NOT AFFECTED BY DEMOLITION SHALL BE MAINTAINED. ALL CIRCUITS SHALL BE VERIFIED WITH EXISTING DRAWINGS AND ACTUAL FIELD CONDITIONS PRIOR TO BEGINNING DEMOLITION.
- G. PHASING: CONTRACTOR IS REQUIRED TO COORDINATE THE REMOVAL AND/OR SHUTDOWN OF ANY EXISTING SYSTEMS AND ANY RELATED MECHANICAL, PLUMBING OR FIRE PROTECTION SYSTEMS REQUIRED FOR THIS PROJECT TO MAINTAIN THE EXISTING BUILDING OPERATIONS THROUGHOUT THE COURSE OF CONSTRUCTION. CONFORM TO THE PROJECT CONSTRUCTION SCHEDULE PHASING SEQUENCE AND INTENT IDENTIFIED BY THE CONSTRUCTION MANAGER AND ARCHITECT. CONTRACTOR SHALL COORDINATE ALLOWABLE WORKING HOURS IN SPECIFIC AREAS OF THE EXISTING BUILDING WITH THE CONSTRUCTION MANAGER. IF AFTER HOURS WORK IS REQUIRED, PREMIUM TIME SHALL BE INCLUDED IN BID. ANY REQUIRED DEMOLITION, RELOCATION OR SHUTDOWN OF EXISTING SYSTEMS SHALL BE SUBMITTED FOR APPROVAL A MINIMUM OF TWO (2) WEEKS PRIOR TO PERFORMING THE REQUIRED WORK. NO DEMOLITION WORK AFFECTING EXISTING SYSTEMS TO REMAIN SHALL BE PERFORMED WITHOUT APPROVAL FROM THE CONSTRUCTION MANAGER. INCLUDE ANY TEMPORARY FACILITIES REQUIRED TO MAINTAIN EXISTING SYSTEMS IN OPERATION DURING THE COURSE OF DEMOLITION WORK IN BID.

CODED NOTES

- ① ALL LIGHTING FIXTURES, DEVICES AND CONTROLS IN THIS AREA SHALL BE MADE SAFE FOR DEMOLITION UNLESS NOTED OTHERWISE - 'XR'. ELECTRICAL DEMOLITION SHALL BE PERFORMED PER THE GENERAL DEMOLITION NOTES. REMOVE ALL WIRING, CONDUIT, BOXES, ETC. ASSOCIATED WITH THE FIXTURES AND DEVICES BACK TO THEIR SOURCE OR NEAREST POINT OF COMMON USE. MAINTAIN ALL POWER, DATA WIRING AND CONDUIT RUNNING THROUGH THIS SPACE THAT FEEDS EXISTING SPACES TO REMAIN OR THAT IS TO BE REUSED OR MODIFIED UNDER THE NEW WORK SCOPE. IDENTIFY THIS CONDUIT AND WIRING TO PREVENT DAMAGE DURING DEMOLITION. THE EXACT EXTENT OF DEMOLITION AREA SHOULD BE CONFIRMED WITH THE ARCHITECTURAL DEMOLITION DRAWINGS.
- ② MAINTAIN ALL LIGHTING FIXTURES, DEVICES AND CONTROLS WITHIN THIS SPACE - 'X'.



① MAIN LEVEL LIGHTING DEMO PLAN - KDPS
ED101 1/8" = 1'-0"



KEY PLAN - KDPS
NTS

McHenry & Associates Incorporated
Mc&A
 Consulting Engineers est. 1960
 25001 Emery Road, Suite #200
 Warrensville Heights, Ohio 44128
 Phone: 216-292-4696
 Fax: 216-292-5874
 Email: mail@mcHenryassociates.com

City of Kalamazoo - Crosstown Facility
 CPED & KDPS Workplace Renovation
 150 E Crosstown Parkway Kalamazoo MI 49001

Seal:

BID Set 08/21/2025
 © 2025, intersect studio, llc
 Project Number: 23-046

LIGHTING DEMO PLAN - MAIN LEVEL KDPS

ED101

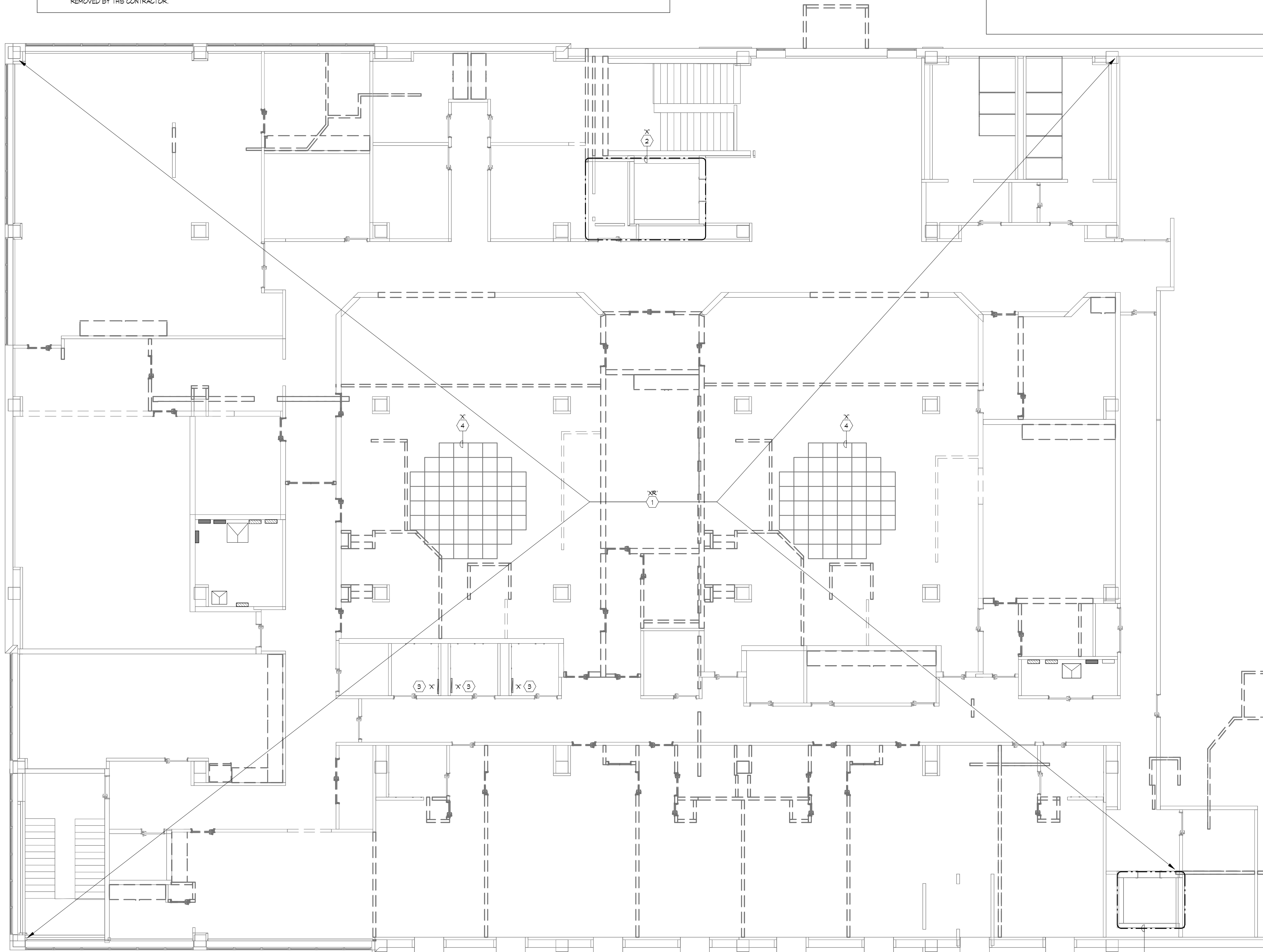
GENERAL DEMOLITION NOTES:

- A. THIS CONTRACTOR SHALL PERFORM ALL DEMOLITION OF EXISTING ELECTRICAL SYSTEMS AS INDICATED ON ELECTRICAL AND ARCHITECTURAL PLANS OR AS NECESSARY FOR THE PROJECT. REMOVE FROM SITE AND PROPERLY DISPOSE OF ALL MATERIAL AND DEBRIS FROM THIS WORK.
- B. DEMOLITION DRAWINGS ARE GENERAL IN NATURE SHOWING THE SCOPE OF DEMOLITION WORK. CONTRACTOR SHALL VISIT THE SITE AND BECOME FAMILIAR WITH THE QUANTITY OF LIGHT FIXTURES, OUTLETS, ETC. REMOVE ALL EQUIPMENT AND DEVICES NO LONGER REQUIRED FOR FINISHED CONSTRUCTION. ALL EXISTING LIGHTS, CONDUIT, WIRE AND DEVICES IN PROJECT AREAS SHALL BE REMOVED AND DISPOSED OF. REMOVE CONDUITS BEYOND NEW SURFACES. REMOVE ALL EXISTING WIRE FROM CONDUIT BACK TO POINT OF COMMON USE OR TO PANELS. LABEL EXISTING CIRCUIT BREAKERS "SPARE" IF NOT REUSED FOR NEW WORK.
- C. DISCONNECT EXISTING EQUIPMENT IN BUILDING THAT IS TO BE REMOVED UNDER OTHER SECTIONS. REMOVE DATA AND PHONE CABLING SYSTEM AS DIRECTED BY OWNER. NO CABLES SHALL BE REMOVED OR CUT WITHOUT APPROVAL FROM OWNER. ANY EXISTING CABLES TO REMAIN SHALL BE SUPPORTED FROM STRUCTURE BEFORE CEILING REMOVAL.
- D. PATCH ALL SURFACES TO MATCH SURROUNDINGS FOR DEVICES TO BE REMOVED FROM EXISTING WALLS TO BE MAINTAINED. EXISTING ROUGH-IN BOXES IN WALL TO REMAIN MAY BE REUSED IF CODE COMPLIANT AND APPROVED FOR LOCATION BY ARCHITECT.
- E. THE OWNER RESERVES THE RIGHT OF SALVAGE FOR ALL EXISTING ELECTRICAL EQUIPMENT PRIOR TO DEMOLITION. THE CONTRACTOR SHALL REVIEW ALL MATERIALS AND DELIVER TO THE OWNER THOSE REQUIRED IN THEIR EXISTING CONDITION. ALL OTHER MATERIAL SHALL BE REMOVED BY THIS CONTRACTOR.
- F. ALL CIRCUITS WHICH ARE REQUIRED TO REMAIN ACTIVE SHALL BE MAINTAINED OR REWORKED AS REQUIRED. ANY EXISTING CIRCUITS OR CABLING SYSTEMS SERVING AREAS NOT AFFECTED BY DEMOLITION SHALL BE MAINTAINED. ALL CIRCUITS SHALL BE VERIFIED WITH EXISTING DRAWINGS AND ACTUAL FIELD CONDITIONS PRIOR TO BEGINNING DEMOLITION.
- G. PHASING: CONTRACTOR IS REQUIRED TO COORDINATE THE REMOVAL AND/OR SHUTDOWN OF ANY EXISTING SYSTEMS AND ANY RELATED MECHANICAL, PLUMBING OR FIRE PROTECTION SYSTEMS REQUIRED FOR THIS PROJECT TO MAINTAIN THE EXISTING BUILDING OPERATIONS THROUGHOUT THE COURSE OF CONSTRUCTION. CONFORM TO THE PROJECT CONSTRUCTION SCHEDULE PHASING SEQUENCE AND INTENT IDENTIFIED BY THE CONSTRUCTION MANAGER AND ARCHITECT. CONTRACTOR SHALL COORDINATE ALLOWABLE WORKING HOURS IN SPECIFIC AREAS OF THE EXISTING BUILDING WITH THE CONSTRUCTION MANAGER. IF AFTER HOURS WORK IS REQUIRED, PREMIUM TIME SHALL BE INCLUDED IN BID. ANY REQUIRED DEMOLITION, RELOCATION OR SHUTDOWN OF EXISTING SYSTEMS SHALL BE SUBMITTED FOR APPROVAL A MINIMUM OF TWO (2) WEEKS PRIOR TO PERFORMING THE REQUIRED WORK. NO DEMOLITION WORK AFFECTING EXISTING SYSTEMS TO REMAIN SHALL BE PERFORMED WITHOUT APPROVAL FROM THE CONSTRUCTION MANAGER. INCLUDE ANY TEMPORARY FACILITIES REQUIRED TO MAINTAIN EXISTING SYSTEMS IN OPERATION DURING THE COURSE OF DEMOLITION WORK IN BID.

CODED NOTES

- 1 ALL LIGHTING FIXTURES, DEVICES AND CONTROLS IN THIS AREA SHALL BE MADE SAFE FOR DEMOLITION UNLESS NOTED OTHERWISE - 'XR'. ELECTRICAL DEMOLITION SHALL BE PERFORMED PER THE GENERAL DEMOLITION NOTES. REMOVE ALL WIRING, CONDUIT, BOXES, ETC. ASSOCIATED WITH THE FIXTURES AND DEVICES BACK TO THEIR SOURCE OR NEAREST POINT OF COMMON USE. MAINTAIN ALL POWER, DATA WIRING AND CONDUIT RUNNING THROUGH THIS SPACE THAT FEEDS EXISTING SPACES TO REMAIN OR THAT IS TO BE REUSED OR MODIFIED UNDER THE NEW WORK SCOPE. IDENTIFY THIS CONDUIT AND WIRING TO PREVENT DAMAGE DURING DEMOLITION. THE EXACT EXTENT OF DEMOLITION AREA SHOULD BE CONFIRMED WITH THE ARCHITECTURAL DEMOLITION DRAWINGS.
- 2 MAINTAIN ALL LIGHTING FIXTURES, DEVICES AND CONTROLS WITHIN THIS SPACE - 'X'.
- 3 MAINTAIN EXISTING FIXTURE. NEW CONTROLS WILL BE PROVIDED AS SHOWN ON DRAWING E102.
- 4 MAINTAIN EXISTING CEILING ACRYLIC LENSES. NEW LIGHTS WILL BE PROVIDED TO BACK LIGHT ACRYLIC PANELS AS SHOWN ON E102.

McHenry & Associates Incorporated
MC&A
 Consulting Engineers est. 1960
 25001 Emory Road, Suite #200
 Warrensville Heights, Ohio 44128
 Phone: 216-292-4696
 Fax: 216-292-5874
 Email: mail@mchenryassociates.com

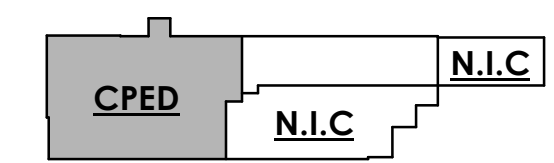


City of Kalamazoo - Crosstown Facility
 CPED & KDPS Workplace Renovation
 150 E Crosstown Parkway Kalamazoo MI 49001

Seal:

BID Set 08/21/2025
 © 2025, intersect studio, llc
 Project Number: 23-046

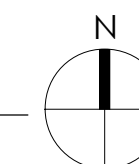
LIGHTING DEMO PLAN - UPPER LEVEL CPED



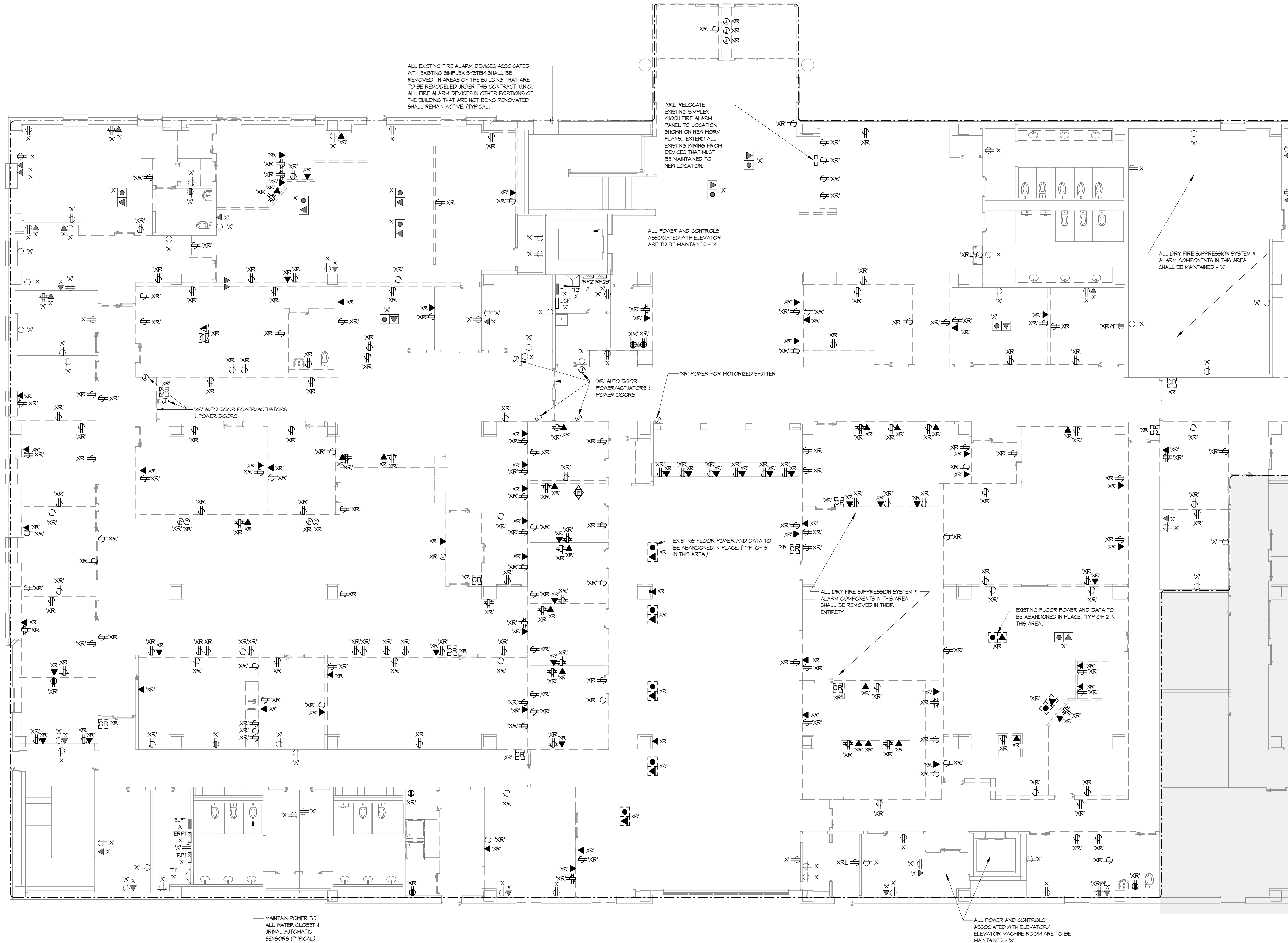
KEY PLAN - CPED
 NTS

ED102

1 UPPER LEVEL LIGHTING DEMO PLAN - CPED
 ED102 1/8" = 1'-0"



City of Kalamazoo - Crosstown Facility
 CPED & KDPS Workplace Renovation
 150 E Crosstown Parkway Kalamazoo MI 49001



ALL EXISTING FIRE ALARM DEVICES ASSOCIATED WITH EXISTING SIMPLEX SYSTEM SHALL BE REMOVED IN AREAS OF THE BUILDING THAT ARE TO BE RENOVATED UNDER THIS CONTRACT, U.N.C. ALL FIRE ALARM DEVICES IN OTHER PORTIONS OF THE BUILDING THAT ARE NOT BEING RENOVATED SHALL REMAIN ACTIVE. (TYPICAL)

XR1 RELOCATE EXISTING SIMPLEX 41000 FIRE ALARM PANEL TO LOCATION SHOWN ON NEW WORK PLANS. EXTEND ALL EXISTING WIRING FROM DEVICES THAT MUST BE MAINTAINED TO NEW LOCATION.

ALL POWER AND CONTROLS ASSOCIATED WITH ELEVATOR ARE TO BE MAINTAINED - X

ALL DRY FIRE SUPPRESSION SYSTEM 4 ALARM COMPONENTS IN THIS AREA SHALL BE MAINTAINED - X

XR AUTO DOOR POWER/ACTUATORS POWER DOORS

XR POWER FOR MOTORIZED SHUTTER

EXISTING FLOOR POWER AND DATA TO BE ABANDONED IN PLACE (TYP. OF 5 IN THIS AREA)

ALL DRY FIRE SUPPRESSION SYSTEM 4 ALARM COMPONENTS IN THIS AREA SHALL BE REMOVED IN THEIR ENTIRETY.

EXISTING FLOOR POWER AND DATA TO BE ABANDONED IN PLACE (TYP. OF 2 IN THIS AREA)

MAINTAIN POWER TO ALL WATER CLOSET 4 SERIAL AUTOMATIC SENSORS (TYPICAL)

ALL POWER AND CONTROLS ASSOCIATED WITH ELEVATOR/ELEVATOR MACHINE ROOM ARE TO BE MAINTAINED - X

1 MAIN LEVEL POWER AND SYSTEMS DEMO PLAN - CPED
 ED200 1/8" = 1'-0"

KEY PLAN - CPED
 NTS

Seal:

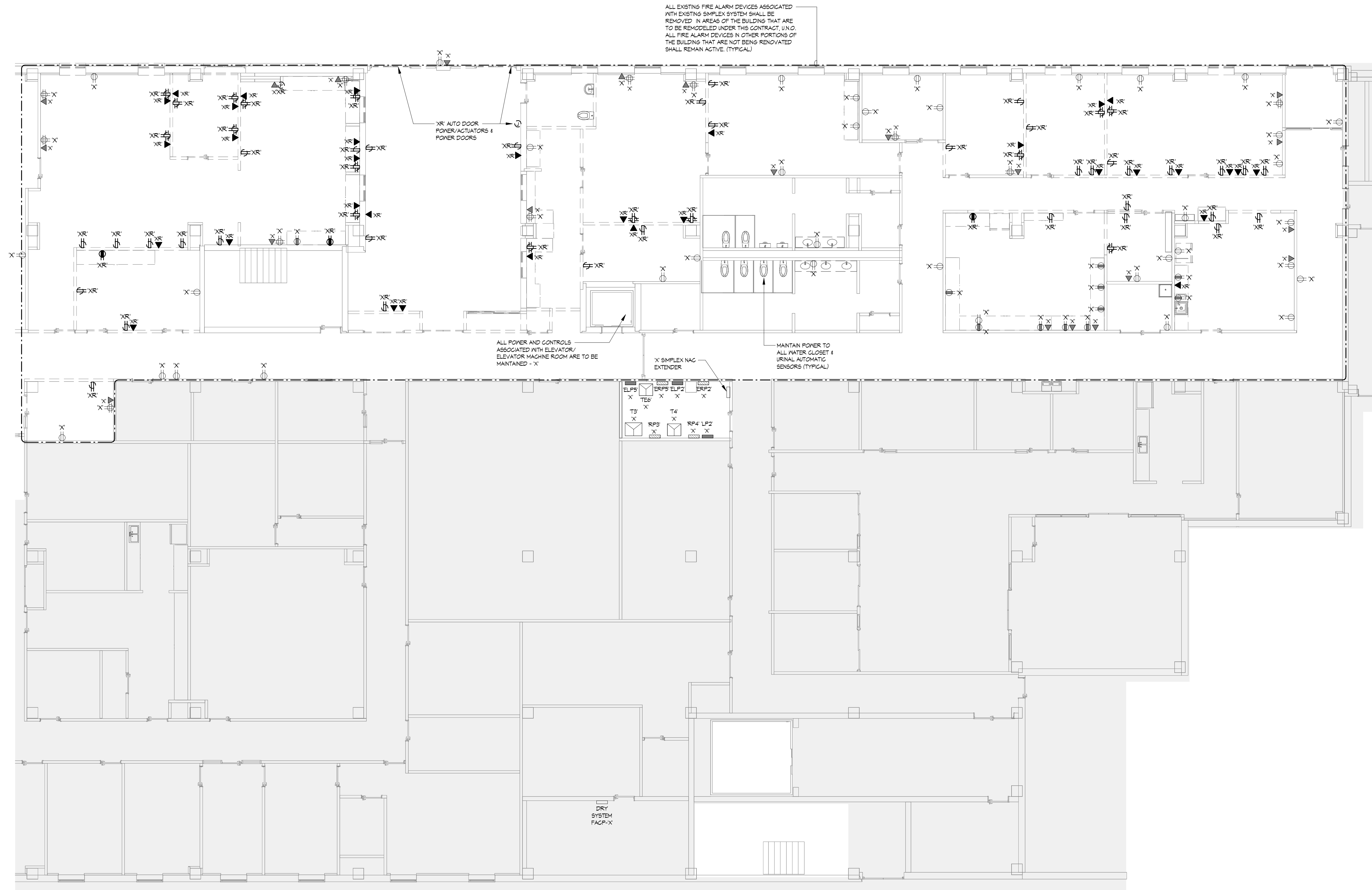
BID Set 08/21/2025
 © 2025, intersect studio, llc
 Project Number: 23-046

**POWER & SYSTEMS
 DEMO PLAN -
 MAIN LEVEL CPED**

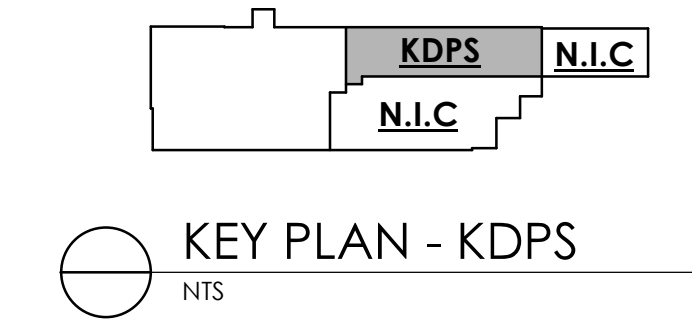
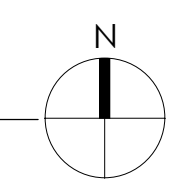
ED200

8/07/2025: P5154 D:\02\Bentley\AECO\MAP_025_McHenry\Plan1.dwg

City of Kalamazoo - Crosstown Facility
 CPED & KDPS Workplace Renovation
 150 E Crosstown Parkway Kalamazoo MI 49001



1 MAIN LEVEL POWER AND SYSTEMS DEMO PLAN - KDPS
 ED201 1/8" = 1'-0"



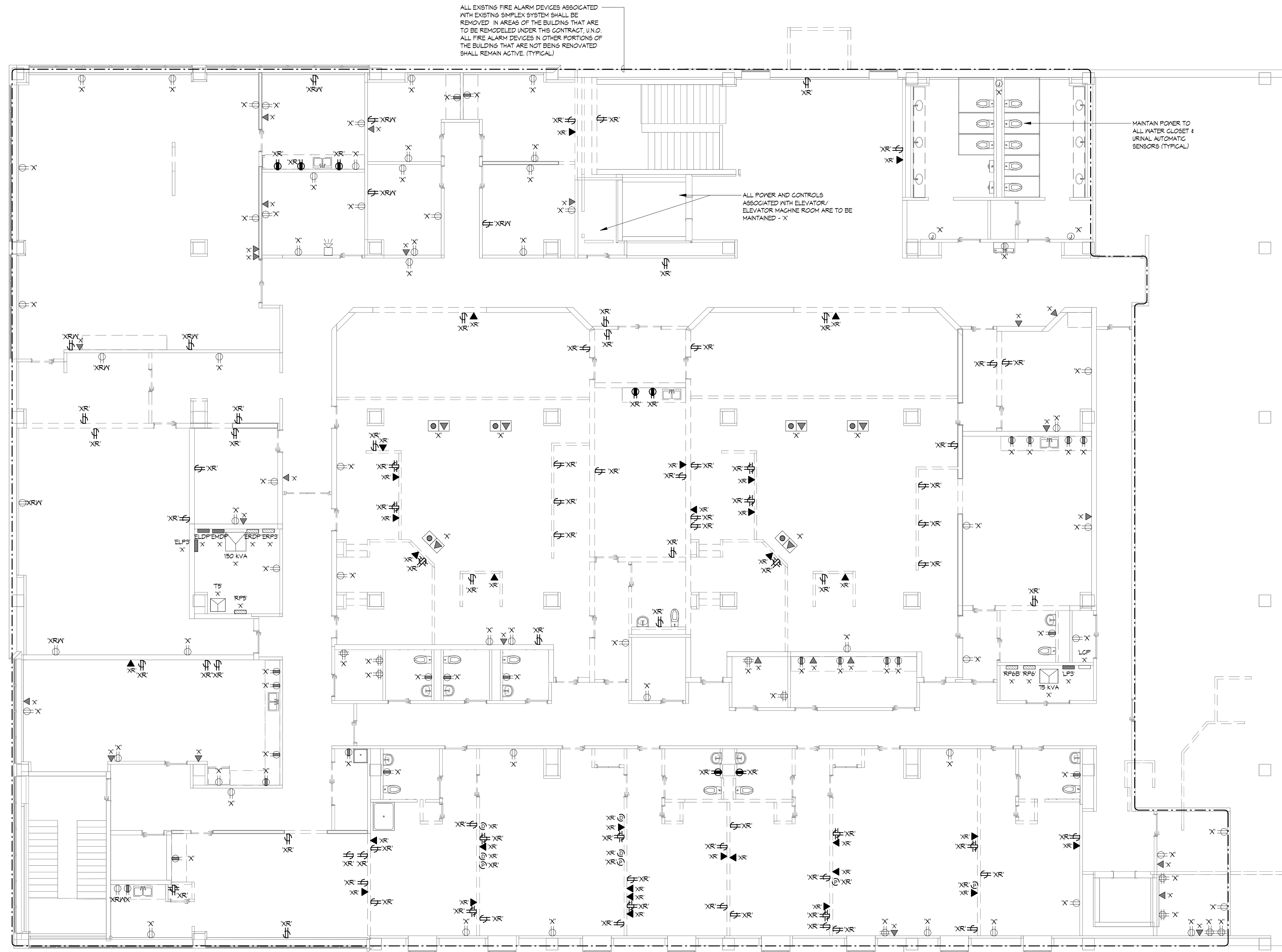
Seal:

BID Set 08/21/2025
 © 2025, intersect studio, llc
 Project Number: 23-046

**POWER & SYSTEMS
 DEMO PLAN -
 MAIN LEVEL KDPS**

ED201

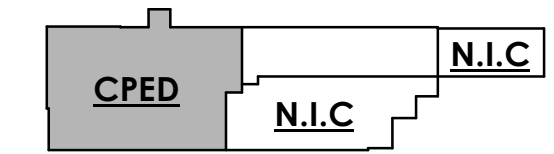
City of Kalamazoo - Crosstown Facility
 CPED & KDPS Workplace Renovation
 150 E Crosstown Parkway Kalamazoo MI 49001



Seal:

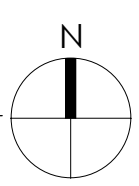
BID Set 08/21/2025
 © 2025, intersect studio, llc
 Project Number: 23-046

**POWER & SYSTEMS
 DEMO PLAN -
 UPPER LEVEL CPED**



KEY PLAN - CPED
 NTS

1 UPPER LEVEL POWER AND SYSTEMS DEMO PLAN - CPED
 1/8" = 1'-0"



ED202

LEGEND

LIGHT FIXTURE TYPE
 PANEL & CIRCUIT #
 SWITCH LEG OR LCP/LCP2 ZONE
 SWITCH LEG

GENERAL NOTES:

A. SWITCH LEG DESIGNATIONS ARE MATCHED BETWEEN CONTROL DEVICES AND LIGHT FIXTURES LOCATED IN THE SAME ROOM, UNLESS NOTED OTHERWISE. CONTACT ENGINEER IF CLARIFICATION IS REQUIRED.
 B. LETTER SHOWN IN INDICATES AN UNSWITCHED HOT LEG MUST BE BROUGHT TO FIXTURE FOR WIRING OF NIGHT LIGHT (NL) OR AN EXIT SIGN. THIS DESIGNATION IS AN UNCONTROLLED HOT. WIRE AHEAD OF LOCAL SWITCHES, LIGHTING CONTROL, ETC.
 NL = NIGHT LIGHT, ALWAYS ON
 EM = FIXTURE WIRED TO THE LIFE SAFETY BRANCH OF THE EMERGENCY SYSTEM
 [Symbol] = STANDARD FIXTURES DESIGNATED EM
 C. ALL HOMERUNS SHALL BE #12 AWG + GND N 3/4" CONDUIT MINIMUM. INCREASE WIRE SIZE PER VOLTAGE DROP TABLE.
 D. ALL LIGHTING CIRCUITS SHALL HAVE INDIVIDUAL NEUTRAL CONDUCTORS CONTINUOUS FROM PANEL.
 E. THE EXACT LOCATION OF ALL LIGHT FIXTURES SHALL BE AS SHOWN ON THE ARCHITECT'S REFLECTED CEILING PLAN.

VOLTAGE DROP SCHEDULE

120 VOLT BRANCH CIRCUITS UP TO 10 AMPS

TOTAL WIRE LENGTH (FEET)	WIRE SIZE (AWG)
1' - 100'	#12
101' - 150'	#10
151' - 240'	#8
241' - 350'	#6

120 VOLT BRANCH CIRCUITS UP TO 14 AMPS

TOTAL WIRE LENGTH (FEET)	WIRE SIZE (AWG)
1' - 75'	#12
76' - 115'	#10
116' - 155'	#8
156' - 240'	#6

277 VOLT BRANCH CIRCUITS UP TO 16 AMPS

TOTAL WIRE LENGTH (FEET)	WIRE SIZE (AWG)
1' - 140'	#12
141' - 225'	#10
226' - 345'	#8
346' - 545'	#6

MINIMUM BRANCH CIRCUIT WIRING IS #12 AWG. CONTRACTOR SHALL INCREASE WIRE SIZE BASED ON SCHEDULE ABOVE.

BRANCH CIRCUITING GENERAL NOTES

A. ON 20 AMP, 1 POLE CIRCUITS, HOMERUNS SHALL BE 2 #12 AWG + GND N 3/4" CONDUIT MINIMUM. INCREASE WIRE SIZE PER VOLTAGE DROP TABLE.
 B. ALL CIRCUITS SHALL HAVE INDIVIDUAL NEUTRAL CONDUCTORS CONTINUOUS FROM PANEL. SHARED NEUTRALS ARE NOT PERMITTED.

GENERAL NOTES

A. LIGHT FIXTURES SHALL BE SUPPORTED INDEPENDENTLY OF SUSPENDED CEILING OR THE SUSPENDED CEILING SHALL BE SUPPORTED WITHIN SIX (6) INCHES OF EACH CORNER OF FIXTURE IN ACCORDANCE WITH ASTM C-636-26 (LATEST VERSION).
 B. ELECTRICAL CONTRACTOR TO COORDINATE SURFACE MOUNTED FIXTURE MOUNTING WITH ALL MECHANICAL DUCTWORK AND PLUMBING PIPING. WHERE INTERFERENCES OCCUR, ELECTRICAL CONTRACTOR TO PROVIDE INSTRUMENT SUPPORT AS REQUIRED TO ACCOMMODATE FIXTURE LOCATIONS BELOW DUCTWORK, MECHANICAL EQUIPMENT OR PIPING. ALL STRUT BRACING SHALL BE LOCATED DIRECTLY BELOW DUCTWORK/EQUIPMENT PIPING AND NOT DOWN AT FIXTURE. DO NOT BLOCK ANY SECTIONS OF MECHANICAL EQUIPMENT THAT REQUIRE SERVICE ACCESS.
 C. ELECTRICAL CONTRACTOR TO CONFIRM ALL REQUIREMENTS AND LOCATIONS OF ALL EXIT SIGNS AND EMERGENCY LIGHTS WITH LOCAL FIRE AUTHORITIES PRIOR TO ROUGH-IN.
 D. ELECTRICAL CONTRACTOR TO CONFIRM LIGHT FIXTURE CATALOG NUMBERS WITH ALL LIGHT FIXTURES SPECIFIED ON PLANS FOR FIXTURE TRIMS, VOLTAGES, LAMPS, ETC.

CODED NOTES

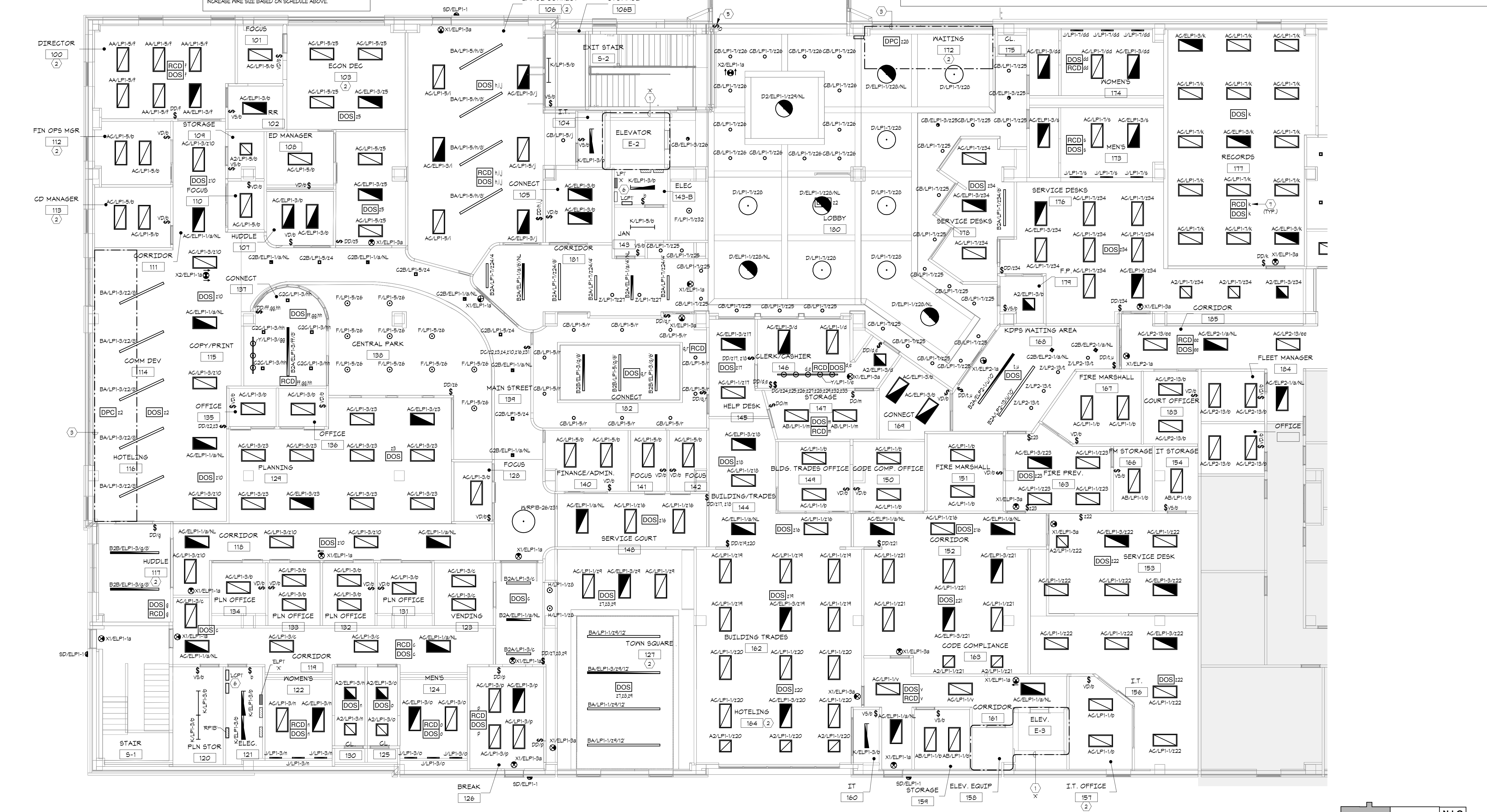
1. MAINTAIN ALL LIGHTING FIXTURES, DEVICES AND CONTROLS WITHIN THIS SPACE - 'X'.
 2. DAYLIGHT ZONE EXEMPT PER 2021 MICHIGAN COMMERCIAL ENERGY CODE 409.2.4(1) - ZONE HAS LESS THAN 150% OF GENERAL LIGHTING WITHIN PRIMARY SEELIT DAYLIGHT ZONE OR LESS THAN 300% OF GENERAL LIGHTING WITHIN ENTIRE SEELIT DAYLIGHT ZONE.
 3. DAYLIGHT HARVESTING ZONE PRIMARY SEELIGHT - ALL LIGHTING FIXTURE(S) THAT FALL FULLY OR PARTIALLY WITHIN THIS AREA TO HAVE THE SAME FUNCTIONALITY AS THE GENERAL LIGHTING EXCEPT A PHOTOSENSOR SHALL BE PROVIDED TO CONTROL THESE FIXTURE INDEPENDENT OF GENERAL LIGHTING CONTROL. REFER TO SINGLE ROOM LIGHTING CONTROLS - MAIN LEVEL OR LIGHTING CONTROL PANEL LCP1 SCHEDULE ON DRAWING E6XX SERIES FOR CONTROL DETAILS AND SEQUENCE OF OPERATION. QUANTITY AND EXACT MOUNTING LOCATION OF ALL PHOTO SENSORS TO BE PROVIDED BY MANUFACTURER.
 4. DAYLIGHT HARVESTING ZONE SECONDARY SEELIGHT - ALL LIGHTING FIXTURE(S) THAT FALL FULLY OR PARTIALLY WITHIN THIS AREA TO HAVE THE SAME FUNCTIONALITY AS THE GENERAL LIGHTING EXCEPT A PHOTOSENSOR SHALL BE PROVIDED TO CONTROL THESE FIXTURE INDEPENDENT OF GENERAL LIGHTING CONTROL. REFER TO SINGLE ROOM LIGHTING CONTROLS - MAIN LEVEL OR LIGHTING CONTROL PANEL LCP1 SCHEDULE ON DRAWING E6XX SERIES FOR CONTROL DETAILS AND SEQUENCE OF OPERATION. QUANTITY AND EXACT MOUNTING LOCATION OF ALL PHOTO SENSORS TO BE PROVIDED BY MANUFACTURER.
 5. DIGITAL AFTER-HOURS OVERRIDE SWITCH FOR LIGHTING CIRCUITS CONTROLLED BY LCP1 WITH INDICATOR LIGHTS AS REQUIRED - SEE DRAWING E601. CONFIRM EXACT LOCATION WITH OWNER, PRIOR TO ROUGH-IN.
 6. PROVIDE 120V EM CIRCUIT (RPH-1) FOR LIGHTING CONTROL PANEL. REFER TO LIGHTING CONTROL SYSTEM DIAGRAM ON DRAWING E601 FOR ADDITIONAL DETAILS. PROVIDE QUANTITY OF CONTROL PANELS AS REQUIRED TO COVER ALL NECESSARY ZONES AS LISTED ON LIGHTING CONTROL PANEL LCP1 SCHEDULE ON DRAWING E6XX SERIES.

McHenry & Associates Incorporated

Mc&A

Consulting Engineers est. 1960

25001 Emery Road, Suite #200
Warrensville Heights, Ohio 44128
Phone: 216-292-4696
Fax: 216-292-5874
Email: mail@mcHenryassociates.com

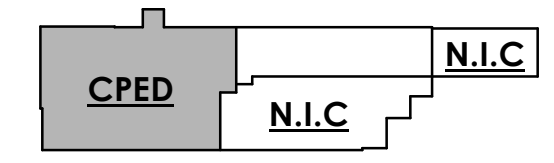


City of Kalamazoo - Crosstown Facility
 CPED & KDPS Workplace Renovation
 150 E Crosstown Parkway Kalamazoo MI 49001

Seal:

BID Set 08/21/2025
 © 2025, intersect studio, llc
 Project Number: 23-046

LIGHTING PLAN -
 MAIN LEVEL CPED



MAIN LEVEL LIGHTING PLAN - CPED
 1/8" = 1'-0"

KEY PLAN - CPED
 NTS

E100

8/07/2025 9:52:24
 D:\02\Rev\14501_MEP_025_MechPlan.rvt

LEGEND

LIGHT FIXTURE TYPE
 PANEL & CIRCUIT #
 SWITCH LEG
 SWITCH LEG OR LCP1/LCP2 ZONE

GENERAL NOTES:

A. SWITCH LEG DESIGNATIONS ARE MATCHED BETWEEN CONTROL DEVICES AND LIGHT FIXTURES LOCATED IN THE SAME ROOM, UNLESS NOTED OTHERWISE. CONTACT ENGINEER IF CLARIFICATION IS REQUIRED.

B. LETTER SHOWN IN INDICATES AN UNSWITCHED HOT LEG MUST BE BROUGHT TO FIXTURE FOR WIRING OF NIGHT LIGHT (NL) OR AN EXIT SIGN. THIS DESIGNATION IS AN UNCONTROLLED HOT WIRE AHEAD OF LOCAL SWITCHES, LIGHTING CONTROL, ETC.

NL = NIGHT LIGHT, ALWAYS ON
 EM = FIXTURE WIRE TO THE LIFE SAFETY BRANCH OF THE EMERGENCY SYSTEM
 [Symbol] = STANDARD FIXTURES DESIGNATED EM

C. ALL HOMERUNS SHALL BE #12 AWG + GND N 3/4" CONDUIT MINIMUM. INCREASE WIRE SIZE PER VOLTAGE DROP TABLE.

D. ALL LIGHTING CIRCUITS SHALL HAVE INDIVIDUAL NEUTRAL CONDUCTORS CONTINUOUS FROM PANEL.

E. THE EXACT LOCATION OF ALL LIGHT FIXTURES SHALL BE AS SHOWN ON THE ARCHITECT'S REFLECTED CEILING PLAN.

VOLTAGE DROP SCHEDULE

120 VOLT BRANCH CIRCUITS UP TO 10 AMPS

TOTAL WIRE LENGTH (FEET)	WIRE SIZE (AWG)
1' - 100'	#12
101' - 150'	#10
151' - 240'	#8
241' - 350'	#6

120 VOLT BRANCH CIRCUITS UP TO 14 AMPS

TOTAL WIRE LENGTH (FEET)	WIRE SIZE (AWG)
1' - 75'	#12
76' - 115'	#10
116' - 155'	#8
156' - 240'	#6

277 VOLT BRANCH CIRCUITS UP TO 16 AMPS

TOTAL WIRE LENGTH (FEET)	WIRE SIZE (AWG)
1' - 140'	#12
141' - 225'	#10
226' - 345'	#8
346' - 546'	#6

MINIMUM BRANCH CIRCUIT WIRING IS #12 AWG. CONTRACTOR SHALL INCREASE WIRE SIZE BASED ON SCHEDULE ABOVE.

BRANCH CIRCUITING GENERAL NOTES

A. ON 20 AMP, 1 POLE CIRCUITS, HOMERUNS SHALL BE 2 #12 AWG + GND N 3/4" CONDUIT MINIMUM. INCREASE WIRE SIZE PER VOLTAGE DROP TABLE.

B. ALL CIRCUITS SHALL HAVE INDIVIDUAL NEUTRAL CONDUCTORS CONTINUOUS FROM PANEL. SHARED NEUTRALS ARE NOT PERMITTED.

GENERAL NOTES

A. LIGHT FIXTURES SHALL BE SUPPORTED INDEPENDENTLY OF SUSPENDED CEILING OR THE SUSPENDED CEILING SHALL BE SUPPORTED WITHIN SIX (6) INCHES OF EACH CORNER OF FIXTURE IN ACCORDANCE WITH ASTM C-636-26 (LATEST VERSION).

B. ELECTRICAL CONTRACTOR TO COORDINATE SURFACE MOUNTED FIXTURE MOUNTING WITH ALL MECHANICAL DUCTWORK AND PLUMBING PIPING. WHERE INTERFERENCES OCCUR, ELECTRICAL CONTRACTOR TO PROVIDE UNSTRUCT SUPPORT AS REQUIRED TO ACCOMMODATE FIXTURE LOCATIONS BELOW DUCTWORK. MECHANICAL EQUIPMENT OR PIPING ALL STRUT BRACING SHALL BE LOCATED DIRECTLY BELOW DUCTWORK/EQUIPMENT PIPING AND NOT DOWN AT FIXTURE. DO NOT BLOCK ANY SECTIONS OF MECHANICAL EQUIPMENT THAT REQUIRE SERVICE ACCESS.

C. ELECTRICAL CONTRACTOR TO CONFIRM ALL REQUIREMENTS AND LOCATIONS OF ALL EXIT SIGNS AND EMERGENCY LIGHTS WITH LOCAL FIRE AUTHORITIES PRIOR TO ROUGH-IN.

D. ELECTRICAL CONTRACTOR TO CONFIRM LIGHT FIXTURE CATALOG NUMBERS WITH ALL LIGHT FIXTURES SPECIFIED ON PLANS FOR FIXTURE TRIMS, VOLTAGES, LAMPS ETC.

CODED NOTES

1. MAINTAIN ALL LIGHTING FIXTURES, DEVICES AND CONTROLS WITHIN THIS SPACE - X.

2. DAYLIGHT ZONE EXEMPT PER 2021 MICHIGAN COMMERCIAL ENERGY CODE 409.2.4(1) - ZONE HAS LESS THAN 150% OF GENERAL LIGHTING WITHIN PRIMARY SIDE-LIGHT ZONE OR LESS THAN 500% OF GENERAL LIGHTING WITHIN ENTIRE SIDE-LIGHT ZONE.

3. DAYLIGHT HARVESTING ZONE PRIMARY SIDE-LIGHT - ALL LIGHTING FIXTURE(S) THAT FALL FULLY OR PARTIALLY WITHIN THIS AREA TO HAVE THE SAME FUNCTIONALITY AS THE GENERAL LIGHTING EXCEPT A PHOTOSENSOR SHALL BE PROVIDED TO CONTROL THESE FIXTURE INDEPENDENT OF GENERAL LIGHTING CONTROL. REFER TO SINGLE ROOM LIGHTING CONTROLS - MAIN LEVEL OR LIGHTING CONTROL PANEL LCP1 SCHEDULE ON DRAWING E&X SERIES FOR CONTROL DETAILS AND SEQUENCE OF OPERATION. QUANTITY AND EXACT MOUNTING LOCATION OF ALL PHOTO SENSORS TO BE PROVIDED BY MANUFACTURER.

4. PROVIDE 120V EM CIRCUIT (ERP1-1) FOR LIGHTING CONTROL PANEL REFER TO LIGHTING CONTROL SYSTEM DIAGRAM ON DRAWING E&X FOR ADDITIONAL DETAILS. PROVIDE QUANTITY OF CONTROLS PANELS AS REQUIRED TO COVER ALL NECESSARY ZONES AS LISTED ON LIGHTING CONTROL PANEL LCP1 SCHEDULE ON DRAWING E&X SERIES.

5. DIGITAL AFTER-HOURS OVERRIDE SWITCH FOR LIGHTING CIRCUITS CONTROLLED BY LCP1, WITH INDICATOR LIGHTS AS REQUIRED - SEE DRAWING E&X1. CONFIRM EXACT LOCATION WITH OWNER, PRIOR TO ROUGH-IN.

6. DAYLIGHT HARVESTING ZONE SECONDARY SIDE-LIGHT - ALL LIGHTING FIXTURE(S) THAT FALL FULLY OR PARTIALLY WITHIN THIS AREA TO HAVE THE SAME FUNCTIONALITY AS THE GENERAL LIGHTING EXCEPT A PHOTOSENSOR SHALL BE PROVIDED TO CONTROL THESE FIXTURE INDEPENDENT OF GENERAL LIGHTING CONTROL. PRIMARY SIDE-LIGHT CONTROL. REFER TO SINGLE ROOM LIGHTING CONTROLS - MAIN LEVEL OR LIGHTING CONTROL PANEL LCP1 SCHEDULE ON DRAWING E&X SERIES FOR CONTROL DETAILS AND SEQUENCE OF OPERATION. QUANTITY AND EXACT MOUNTING LOCATION OF ALL PHOTO SENSORS TO BE PROVIDED BY MANUFACTURER.

7. REFER TO SINGLE ROOM LIGHTING CONTROLS - MAIN LEVEL SCHEDULE ON DRAWING E&X SERIES FOR CONTROL DETAILS AND SEQUENCE OF OPERATION. ROOM CONTROLLER SHALL BE INSTALLED ABOVE CEILING, IN ACCESSIBLE LOCATION, WHERE POSSIBLE. OTHERWISE, ARCHITECT SHALL PROVIDE ACCESS PANEL.

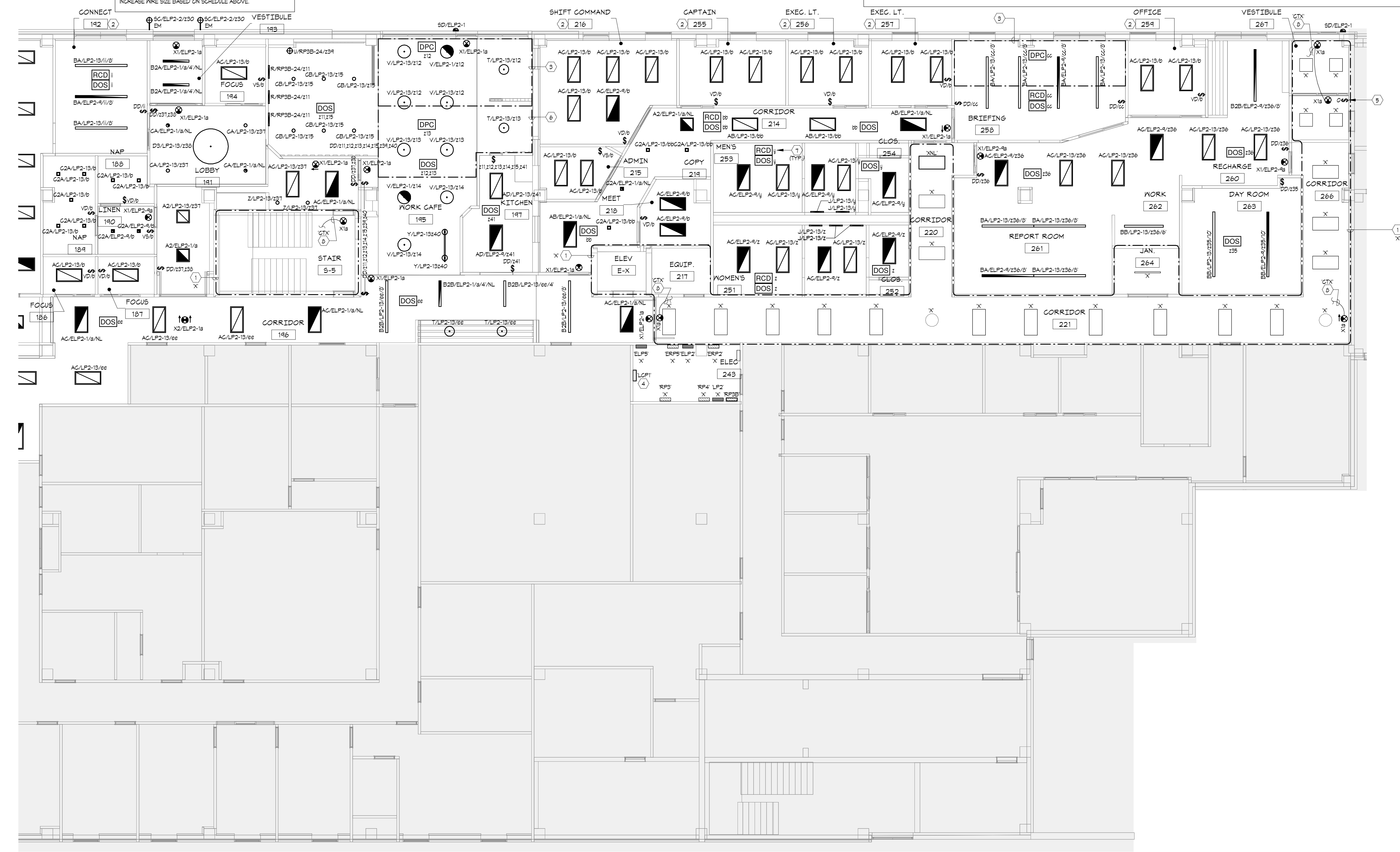
8. CONNECT TO EXISTING EMERGENCY CIRCUIT IN THIS AREA.

McHenry & Associates Incorporated

Mc&A

Consulting Engineers est. 1960

25001 Emery Road, Suite #200
 Warrensville Heights, Ohio 44128
 Phone: 216-292-4696
 Fax: 216-292-5874
 Email: mail@mcHenryassociates.com

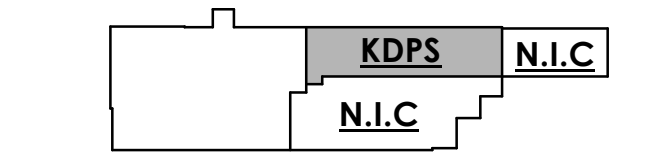


City of Kalamazoo - Crosstown Facility
 CPED & KDPS Workplace Renovation
 150 E Crosstown Parkway Kalamazoo MI 49001

Seal:

BID Set 08/21/2025
 © 2025, intersect studio, llc
 Project Number: 23-046

LIGHTING PLAN - MAIN LEVEL KDPS



1 MAIN LEVEL LIGHTING PLAN - KDPS
 1/8" = 1'-0"

KEY PLAN - KDPS
 NTS

E101

8/07/2025 9:52:32 D:\02\Bentley\4501_WEP_025_McHenry\Plan1.dwg

LEGEND

LIGHT FIXTURE TYPE
 PANEL # CIRCUIT #
 SWITCH LEG OR LCP1/LCP2 ZONE

GENERAL NOTES:

A. SWITCH LEG DESIGNATIONS ARE MATCHED BETWEEN CONTROL DEVICES AND LIGHT FIXTURES LOCATED IN THE SAME ROOM, UNLESS NOTED OTHERWISE. CONTACT ENGINEER IF CLARIFICATION IS REQUIRED.
 B. LETTER SHOWN IN INDICATES AN UNSWITCHED HOT LEG MUST BE BROUGHT TO FIXTURE FOR WIRING OF NIGHT LIGHT (NL) OR AN EXIT SIGN. THIS DESIGNATION IS AN UNCONTROLLED HOT WIRE AHEAD OF LOCAL SWITCHING, LIGHTING CONTROL, ETC.
 NL = NIGHT LIGHT, ALWAYS ON
 EM = FIXTURE WIRED TO THE LIFE SAFETY BRANCH OF THE EMERGENCY SYSTEM
 ■ = STANDARD FIXTURES DESIGNATED EM.
 C. ALL HOMERUN SHALL BE #12 AWG + GND IN 3/4" CONDUIT MINIMUM. INCREASE WIRE SIZE PER VOLTAGE DROP TABLE.
 D. ALL LIGHTING CIRCUITS SHALL HAVE INDIVIDUAL NEUTRAL CONDUCTORS CONTINUOUS FROM PANEL.
 E. THE EXACT LOCATION OF ALL LIGHT FIXTURES SHALL BE AS SHOWN ON THE ARCHITECT'S REFLECTED CEILING PLAN.

VOLTAGE DROP SCHEDULE

120 VOLT BRANCH CIRCUITS UP TO 10 AMPS

TOTAL WIRE LENGTH (FEET)	WIRE SIZE (AWG)
100	#12
101 - 150	#10
151 - 240	#8
241 - 300	#6

120 VOLT BRANCH CIRCUITS UP TO 14 AMPS

TOTAL WIRE LENGTH (FEET)	WIRE SIZE (AWG)
75	#12
76 - 115	#10
116 - 105	#8
106 - 240	#6

277 VOLT BRANCH CIRCUITS UP TO 16 AMPS

TOTAL WIRE LENGTH (FEET)	WIRE SIZE (AWG)
140	#12
141 - 225	#10
226 - 345	#8
346 - 546	#6

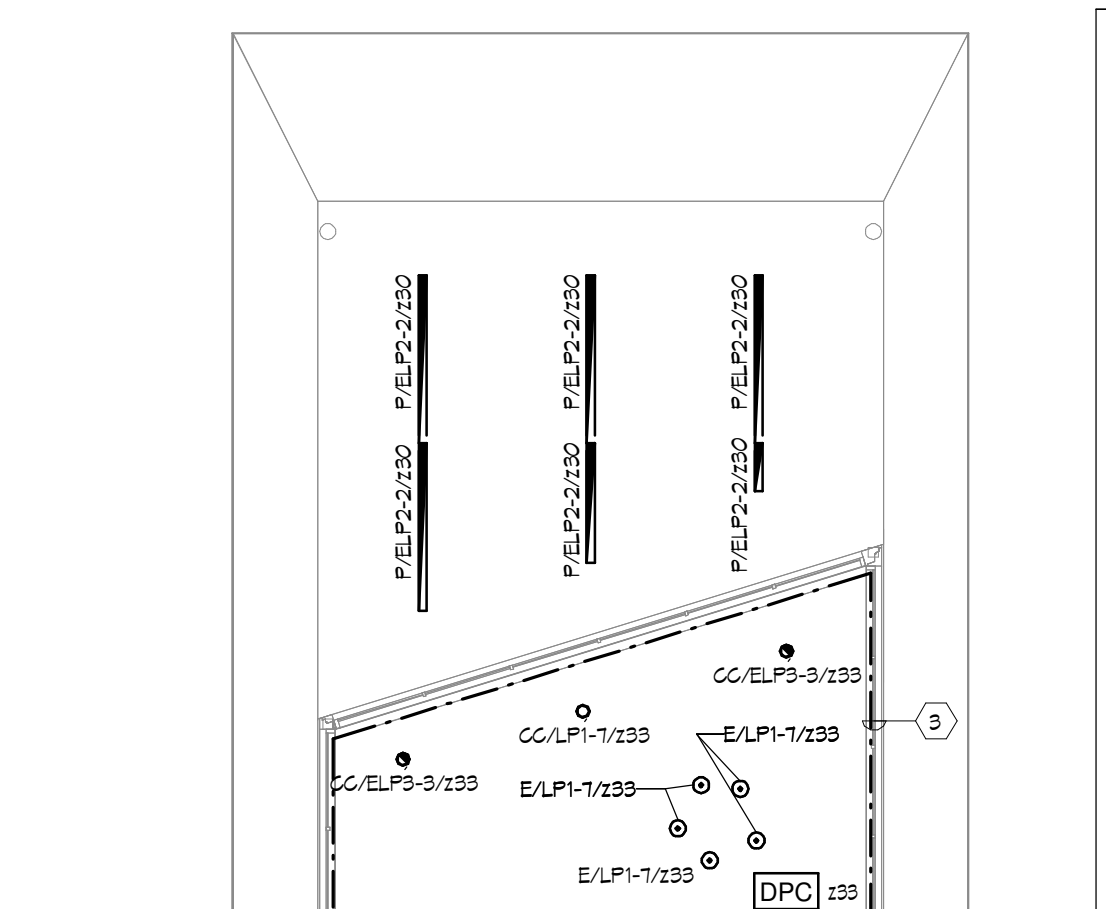
MINIMUM BRANCH CIRCUIT WIRING IS #12 AWG. CONTRACTOR SHALL INCREASE WIRE SIZE BASED ON SCHEDULE ABOVE.

BRANCH CIRCUITING GENERAL NOTES

A. ON 20 AMP, 1 POLE CIRCUITS, HOMERUNS SHALL BE #12 AWG + GND IN 3/4" CONDUIT MINIMUM. INCREASE WIRE SIZE PER VOLTAGE DROP TABLE.
 B. ALL CIRCUITS SHALL HAVE INDIVIDUAL NEUTRAL CONDUCTORS CONTINUOUS FROM PANEL. SHARED NEUTRALS ARE NOT PERMITTED.

GENERAL NOTES

A. LIGHT FIXTURES SHALL BE SUPPORTED INDEPENDENTLY OF SUSPENDED CEILING OR THE SUSPENDED CEILING SHALL BE SUPPORTED WITH SIX (6) INCHES OF EACH CORNER OF FIXTURE IN ACCORDANCE WITH ASTM C-636-26 (LATEST VERSION).
 B. ELECTRICAL CONTRACTOR TO COORDINATE SURFACE MOUNTED FIXTURE MOUNTING WITH ALL MECHANICAL DUCTWORK AND PLUMBING PIPING. WHERE INTERFERENCES OCCUR, ELECTRICAL CONTRACTOR TO PROVIDE INSTRUMENT SUPPORT AS REQUIRED TO ACCOMMODATE FIXTURE LOCATIONS BELOW DUCTWORK, MECHANICAL EQUIPMENT OR PIPING. ALL STRUT BRACINGS SHALL BE LOCATED DIRECTLY BELOW DUCTWORK/EQUIPMENT/PIPING AND NOT DOWN AT FIXTURE. DO NOT BLOCK ANY SECTIONS OF MECHANICAL EQUIPMENT THAT REQUIRE SERVICE ACCESS.
 C. ELECTRICAL CONTRACTOR TO CONFIRM ALL REQUIREMENTS AND LOCATIONS OF ALL EXIT SIGNS AND EMERGENCY LIGHTS WITH LOCAL FIRE AUTHORITIES PRIOR TO ROUGH-IN.
 D. ELECTRICAL CONTRACTOR TO CONFIRM LIGHT FIXTURE CATALOG NUMBERS WITH ALL LIGHT FIXTURES SPECIFIED ON PLANS FOR FIXTURE TRIMS, VOLTAGES, LAMPS ETC.

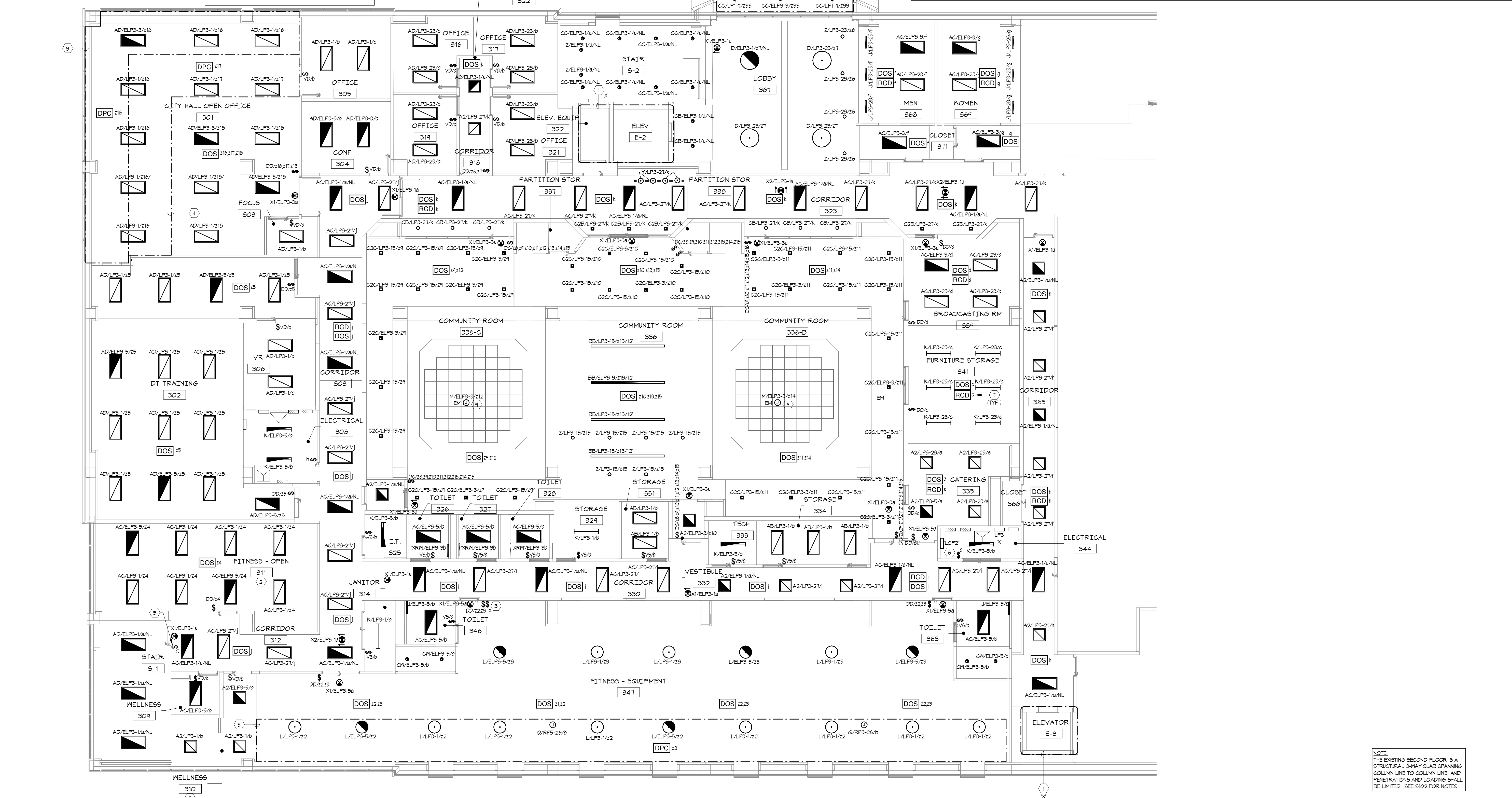


CODED NOTES

1. MAINTAIN ALL LIGHTING FIXTURES, DEVICES AND CONTROLS WITHIN THIS SPACE - 'X'.
 2. DAYLIGHT ZONE ENDS PER 2021 MICHIGAN COMMERCIAL ENERGY CODE (MCEC 408.2.4(1)) - ZONE HAS LESS THAN 50% OF GENERAL LIGHTING WITHIN PRIMARY SIDE-LIGHT ZONE OR LESS THAN 300% OF GENERAL LIGHTING WITHIN ENTIRE SIDE-LIGHT ZONE.
 3. DAYLIGHT HARVESTING ZONE PRIMARY SIDE-LIGHT - ALL LIGHTING FIXTURE(S) THAT FALL FULLY OR PARTIALLY WITHIN THIS AREA TO HAVE THE SAME FUNCTIONALITY AS THE GENERAL LIGHTING EXCEPT A PHOTOSENSOR SHALL BE PROVIDED TO CONTROL THESE FIXTURE INDEPENDENT OF GENERAL LIGHTING CONTROL. REFER TO SINGLE ROOM LIGHTING CONTROLS - UPPER LEVEL OR LIGHTING CONTROL PANEL OR LIGHTING CONTROL PANEL LCP2 SCHEDULE ON DRAWING E60X SERIES FOR CONTROL DETAILS AND SEQUENCE OF OPERATION. QUANTITY AND EXACT MOUNTING LOCATION OF ALL PHOTO SENSORS TO BE PROVIDED BY MANUFACTURER.
 4. DAYLIGHT HARVESTING ZONE SECONDARY SIDE-LIGHT - ALL LIGHTING FIXTURE(S) THAT FALL FULLY OR PARTIALLY WITHIN THIS AREA TO HAVE THE SAME FUNCTIONALITY AS THE GENERAL LIGHTING EXCEPT A PHOTOSENSOR SHALL BE PROVIDED TO CONTROL THESE FIXTURE INDEPENDENT OF GENERAL LIGHTING CONTROL. REFER TO SINGLE ROOM LIGHTING CONTROLS - UPPER LEVEL OR LIGHTING CONTROL PANEL OR LIGHTING CONTROL PANEL LCP2 SCHEDULE ON DRAWING E60X SERIES FOR CONTROL DETAILS AND SEQUENCE OF OPERATION. QUANTITY AND EXACT MOUNTING LOCATION OF ALL PHOTO SENSORS TO BE PROVIDED BY MANUFACTURER.
 5. DIGITAL AFTER-HOURS OVERRIDE SWITCH FOR LIGHTING CIRCUITS CONTROLLED BY LCP2 WITH INDICATOR LIGHTS AS REQUIRED - SEE DRAWING E501. CONFIRM EXACT LOCATION WITH OWNER, PRIOR TO ROUGH-IN.
 6. PROVIDE 100V EM CIRCUIT (RPS-11) FOR LIGHTING CONTROL PANEL. REFER TO LIGHTING CONTROL SYSTEM DIAGRAM ON DRAWING E501 FOR ADDITIONAL DETAILS. PROVIDE QUANTITY OF CONTROL PANELS AS REQUIRED TO COVER ALL NECESSARY ZONES AS LISTED ON LIGHTING CONTROL PANEL LCP2 SCHEDULE ON DRAWING E60X SERIES.

7. REFER TO SINGLE ROOM LIGHTING CONTROLS - UPPER LEVEL SCHEDULE ON DRAWING E60X SERIES FOR CONTROL DETAILS AND SEQUENCE OF OPERATION. ROOM CONTROLLER SHALL BE INSTALLED ABOVE CEILING, IN ACCESSIBLE LOCATION, WHERE POSSIBLE. OTHERWISE, ARCHITECT SHALL PROVIDE ACCESS PANEL.
 8. E.G. SHALL INSTALL CEILING FAN CONTROL AS LOCATED BY OWNER. CONFIRM PRIOR TO ROUGH-IN.
 9. E.G. SHALL PROVIDE QUANTITY OF LUMINOUS LED PANELS AS REQUIRED TO COVER ENTIRE AREA ABOVE CEILING PANELS - APPROXIMATE QUANTITY 1140. CONFIRM WITH MANUFACTURER, PRIOR TO ORDERING.

McHenry & Associates Incorporated
Mc&A
 Consulting Engineers est. 1960
 25001 Emory Road, Suite #200
 Warrensville Heights, Ohio 44128
 Phone: 216-292-4696
 Fax: 216-292-5874
 Email: mail@mcHenryassociates.com

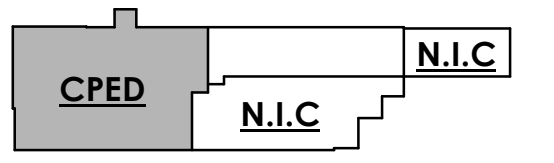


City of Kalamazoo - Crosstown Facility
CPED & KDPS Workplace Renovation
 150 E Crosstown Parkway Kalamazoo MI 49001

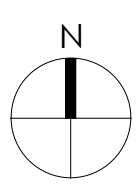
Seal: _____
 BID Set 08/21/2025
 © 2025, intersect studio, llc
 Project Number: 23-046

LIGHTING PLAN - UPPER LEVEL CPED

NOTE:
 THE EXISTING SECOND FLOOR IS A STRUCTURAL 2-WAY SLAB SPANNING COLUMN LINE TO COLUMN LINE, AND PENETRATIONS AND LOADS SHALL BE LIMITED. SEE 5102 FOR NOTES.



1 UPPER LEVEL LIGHTING PLAN - CPED
 1/8" = 1'-0"



KEY PLAN - CPED
 NTS

E102

8/07/2025 9:52:39 D:\02\Bentley\4501_MEP_025_MechPlan.rvt

**BRANCH CIRCUITING
GENERAL NOTES:**

A. ON 20 AMP, 1 POLE CIRCUITS, HOMERUNS SHALL BE 2 #12 AWG + GND IN 3/4" CONDUIT MINIMUM. INCREASE WIRE SIZE PER VOLTAGE DROP TABLE.

B. ALL CIRCUITS SHALL HAVE INDIVIDUAL NEUTRAL CONDUCTORS CONTIGUOUS FROM PANEL. SHARED NEUTRALS ARE NOT PERMITTED.

VOLTAGE DROP SCHEDULE

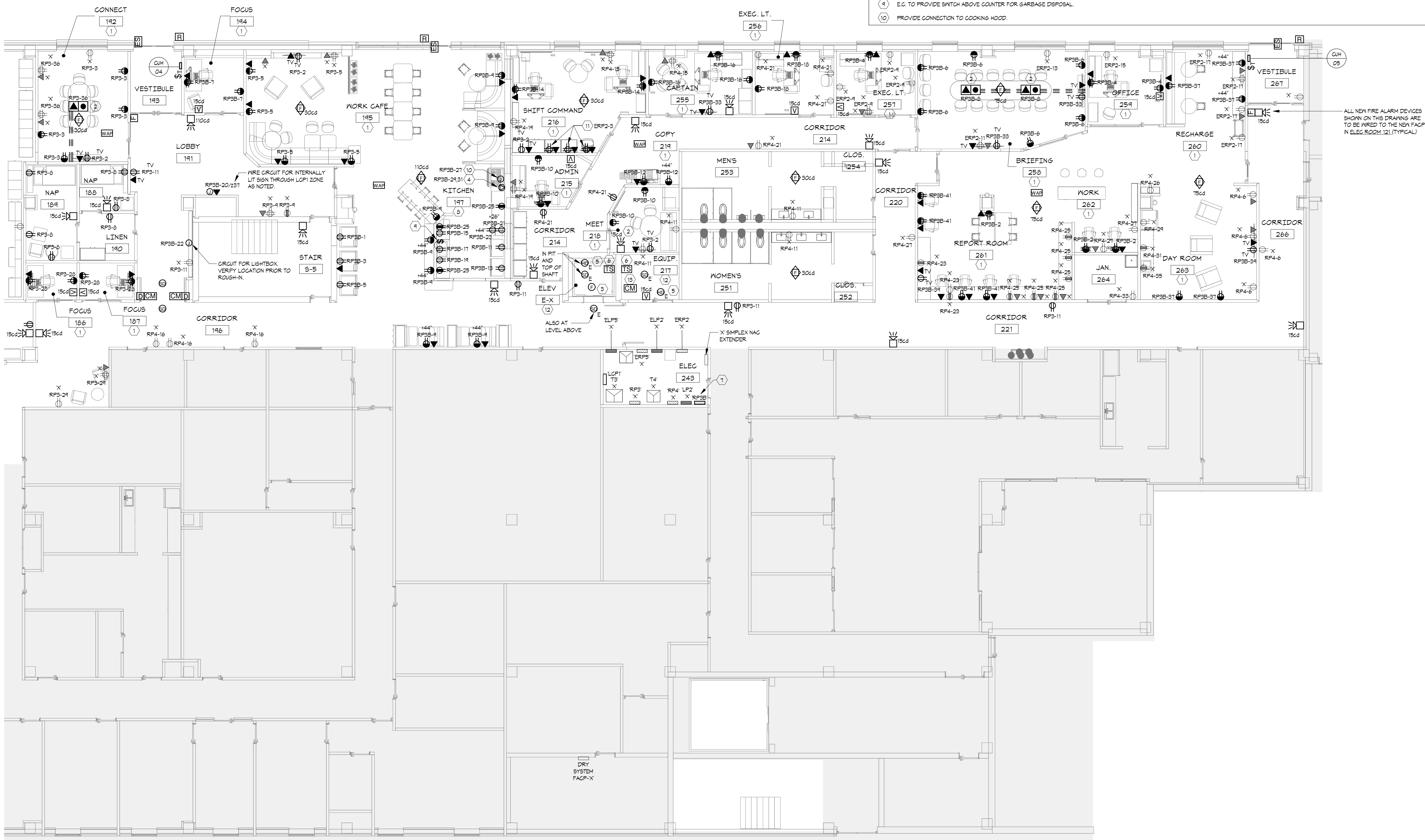
120 VOLT BRANCH CIRCUITS UP TO 10 AMPS		
TOTAL WIRE LENGTH (FEET)		WIRE SIZE (AWG)
1	- 100'	#12
101	- 150'	#10
151	- 240'	#8
241	- 300'	#6

120 VOLT BRANCH CIRCUITS UP TO 14 AMPS		
TOTAL WIRE LENGTH (FEET)		WIRE SIZE (AWG)
1	- 75'	#12
76	- 115'	#10
116	- 185'	#8
186	- 240'	#6

MINIMUM BRANCH CIRCUIT WIRING IS #12 AWG. CONTRACTOR SHALL INCREASE WIRE SIZE BASED ON SCHEDULE ABOVE.

CODED NOTES

- NEW RECEPTACLES IN THIS SPACE ARE SUBJECT TO THE AUTOMATIC RECEPTACLE CONTROL REQUIREMENTS OF THE 2021 MICHIGAN COMMERCIAL ENERGY CODE OUTLINED IN SECTION C409.11. DEVICE SYMBOLS FOR "SWITCHED" RECEPTACLES SHALL BE SPLIT WIRED WITH THE TOP RECEPTACLE BEING FED BY A SWITCHED HOT LEG ROUTED THROUGH A LIGHTING CONTROL PANEL. REFER TO LIGHTING CONTROL SCHEDULES FOR DETAILS.
- PROVIDE UNDER CARPET FLEX RACEWAY SYSTEM AND IN-WALL ENTRANCE END FITTING, AS REQUIRED. COORDINATE EXACT LAYOUT WITH LOCAL LEGRAND/CONNECTRAC VENDOR (WIREMOLD, OR APPROVED EQUAL), OWNER, AND FURNITURE VENDOR, PRIOR TO ORDERING.
- PROVIDE FIRE ALARM SPEAKER ONLY - CEILING MOUNT STYLE, WHITE - IN ELEVATOR. PROVIDE TO ELEVATOR CONTRACTOR FOR INSTALLATION. PROVIDE SPEAKER CIRCUIT TO ELEVATOR EQUIPMENT ROOM AND TRAVELING CABLE AS DIRECTED BY ELEVATOR INSTALLER.
- PROVIDE NEMA 14-50R RECEPTACLE FOR OVEN - 200V, 1PH, 17.5A ASSUMED. COORDINATE ELECTRICAL REQUIREMENTS WITH MANUFACTURER. PROVIDE 3 #6 + #10 GND - 1C.
- LOCATE HEAT DETECTOR WITH FIXED AND RATE OF RISE ELEVATOR WITHIN 24" OF ALL SPRINKLER HEADS IN SHAFT/MACHINE ROOM. SEE ELEVATOR SHUT DOWN WIRING DIAGRAM. CONFIRM ALL LOCATIONS OF SPRINKLER HEADS WITH FIRE PROTECTION SHOP DRAWINGS.
- TAMPER SWITCH IN ELEVATOR SHAFT/MACHINE ROOM AS REQUIRED.
- RELOCATE TIME CLOCK AND CONTACTORS 'C1' AND 'C2' AS REQUIRED TO INSTALL NEW PANEL IN THIS LOCATION.
- ALL RECEPTACLES IN THIS AREA WIRED TO GFCI CIRCUIT BREAKERS.
- E.G. TO PROVIDE SWITCH ABOVE COUNTER FOR GARBAGE DISPOSAL.
- PROVIDE CONNECTION TO COOKING HOOD.
- COORDINATE EXACT QUANTITY AND LOCATION OF ALL CCTV MONITORS, PRIOR TO ROUGH-IN.
- REPLACE ALL FIRE ALARM DEVICES FOR EXISTING ELEVATOR. CONFIRM EXACT QUANTITY OF DEVICES IN THE FIELD, PRIOR TO BIDS.
- PROVIDE MINIMUM OF FOUR CONTROL MODULES FOR RECALL, FIREMAN'S HAT, ETC.



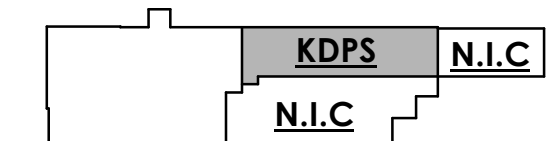
McHenry & Associates Incorporated
Mc&A
 Consulting Engineers est. 1960
 25001 Emory Road, Suite #200
 Warrensville Heights, Ohio 44128
 Phone: 216-292-4696
 Fax: 216-292-5874
 Email: mail@mcHenryassociates.com

City of Kalamazoo - Crosstown Facility
 CPED & KDPS Workplace Renovation
 150 E Crosstown Parkway Kalamazoo MI 49001

Seal:

BID Set 08/21/2025
 © 2025, intersect studio, llc
 Project Number: 23-046

**POWER & SYSTEMS
PLAN - MAIN LEVEL
KDPS**



KEY PLAN - KDPS
 NTS

1 E201 MAIN LEVEL POWER AND SYSTEMS PLAN - KDPS
 1/8" = 1'-0"

E201

8/07/2025 9:52:38 D:\02\Bentley\4501_MEP_025_McHenry\Plan1.dwg

**BRANCH CIRCUITING
GENERAL NOTES:**

- A. ON 20 AMP, 1-POLE CIRCUITS, HOMERUNS SHALL BE 2 #12 AWG + GND IN 3/4" CONDUIT MINIMUM. INCREASE WIRE SIZE PER VOLTAGE DROP TABLE.
- B. ALL CIRCUITS SHALL HAVE INDIVIDUAL NEUTRAL CONDUCTORS CONTIGUOUS FROM PANEL. SHARED NEUTRALS ARE NOT PERMITTED.

VOLTAGE DROP SCHEDULE

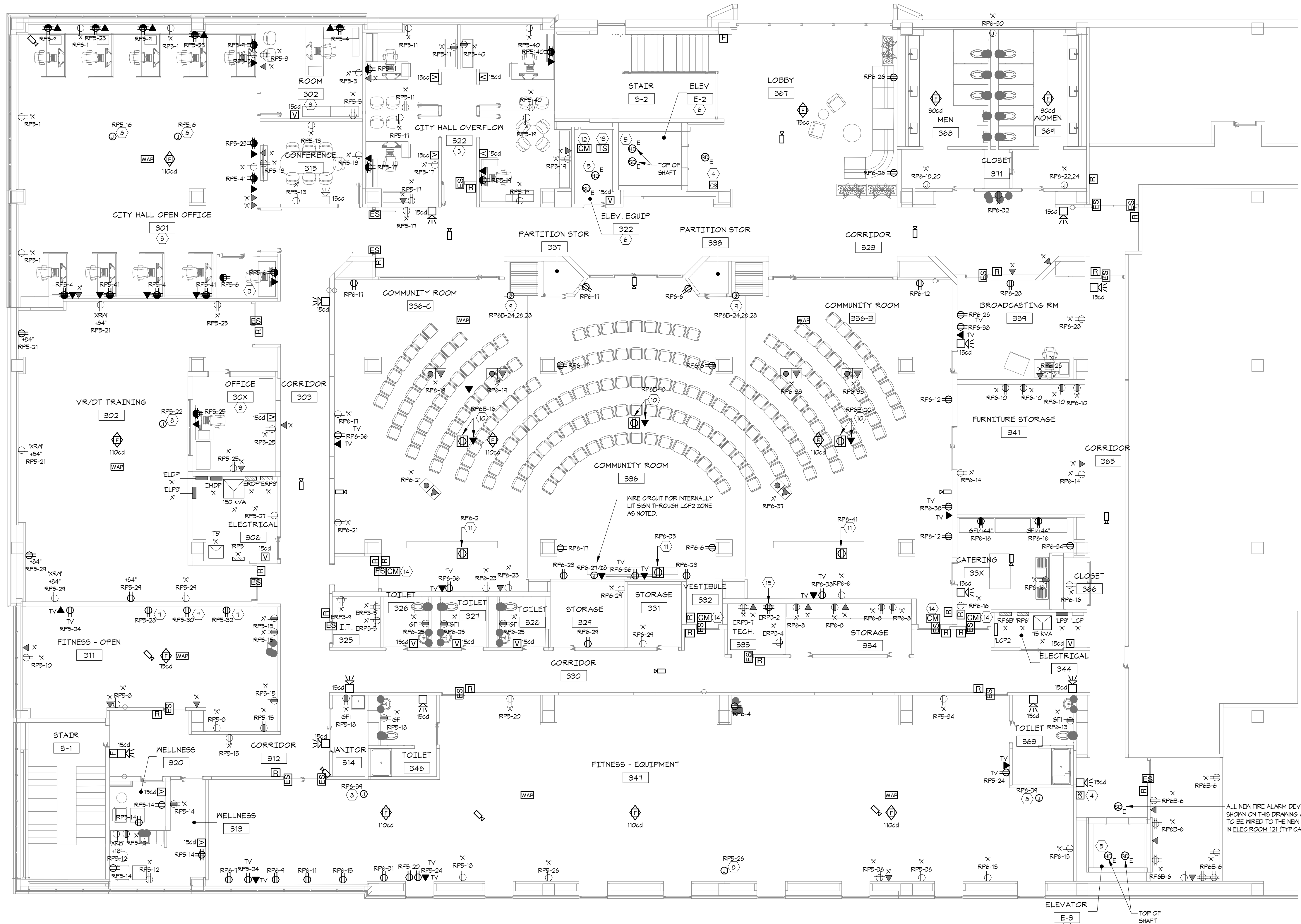
120 VOLT BRANCH CIRCUITS UP TO 10 AMPS		
TOTAL WIRE LENGTH (FEET)	WIRE SIZE (AWG)	
1'	-	#12
101'	-	#10
151'	-	#8
241'	-	#6

120 VOLT BRANCH CIRCUITS UP TO 14 AMPS		
TOTAL WIRE LENGTH (FEET)	WIRE SIZE (AWG)	
1'	-	#12
16'	-	#10
116'	-	#8
186'	-	#6

MINIMUM BRANCH CIRCUIT WIRING IS #12 AWG. CONTRACTOR SHALL INCREASE WIRE SIZE BASED ON SCHEDULE ABOVE.

CODED NOTES

1. PROVIDE 2" SQUARE DIVIDED POWER POLE FOR POWER/DATA DROP TO SYSTEMS FURNITURE. FINISH BY ARCHITECT. CIRCUIT ARRANGEMENT TO BE COORDINATED WITH FINAL SYSTEMS FURNITURE SELECTION. EXTEND POWERPOLE UP TO STRUCTURE THROUGH ANY SUSPENDED CEILING AND SUPPORT AT STRUCTURE.
2. PROVIDE POWER AND DATA FEED FOR SYSTEMS FURNITURE. FEED TO BE FLEXIBLE WHP OF ADEQUATE SLACK TO ALLOW ADJUSTMENTS TO FURNITURE POSITIONING. DATA CONDUIT SHALL BE 2" CIRCUIT ARRANGEMENT TO BE COORDINATED WITH FINAL SYSTEMS FURNITURE SELECTION.
3. NEW RECEPTACLES IN THIS SPACE ARE SUBJECT TO THE AUTOMATIC RECEPTACLE CONTROL REQUIREMENTS OF THE 2021 MICHIGAN COMMERCIAL ENERGY CODE OUTLINED IN SECTION C405.11. DEVICE SYMBOLS FOR "SWITCHED" RECEPTACLES SHALL BE SPLIT WIRED WITH THE TOP RECEPTACLE BEING FED BY AN UNSWITCHED HOT LEG DIRECTLY FROM THE PANEL. TOP RECEPTACLE SHALL BE FED BY A SWITCHED HOT LEG ROUTED THROUGH A LIGHTING CONTROL PANEL - REFER TO LIGHTING CONTROL SCHEDULES FOR DETAILS.
4. PROVIDE TWO-WAY COMMUNICATION EMERGENCY PHONE AT EACH ELEVATOR LANDINGS NOT ON AN ACCESSIBLE EXIT DISCHARGE LEVEL. AND AT DESIGNATED CENTRAL CONTROL LOCATION, AS DIRECTED BY LOCAL A.H.J. BASIS OF DESIGN SHALL BE RATH COMMERCIAL ELEVATOR PHONE SERIES, OR EQUAL. CONFIRM WITH LOCAL A.H.J. PROVIDE ALL COMPONENTS AND WIRING AS REQUIRED, FOR A COMPLETE OPERATING SYSTEM.
5. LOCATE HEAT DETECTOR WITH FIXED AND RATE OF RISE ELEMENT WITHIN 24" OF ALL SPRINKLER HEADS IN SHAFT/MACHINE ROOM. SEE ELEVATOR SHUT DOWN WIRING DIAGRAM. CONFIRM ALL LOCATIONS OF SPRINKLER HEADS WITH FIRE PROTECTION SHOP DRAWINGS.
6. REPLACE ALL FIRE ALARM DEVICES FOR EXISTING ELEVATOR. CONFIRM EXACT QUANTITY OF DEVICES IN THE FIELD, PRIOR TO BIDS.
7. CONFIRM EXACT LOCATION FOR SAUNA RECEPTACLE. PRIOR TO ROUGH-IN.
8. PROVIDE NEW CIRCUIT TO LBOX ABOVE CEILING - LABEL FUTURE.
9. OPERABLE PARTITION - E.G. TO PROVIDE CIRCUIT AS SHOWN, AND E.G. TO INSTALL AND WIRE ALL ASSOCIATED CONTROLS, FOR A COMPLETE WORKING SYSTEM. CONFIRM CONTROL LOCATIONS WITH OWNER, PRIOR TO ROUGH-IN.
10. 120V AND DATA ROUGH-IN FOR PENDANT/CEILING MOUNTED PROJECTOR. CONFIRM EXACT LOCATION WITH OWNER, PRIOR TO ROUGH-IN.
11. 120V FOR MOTORIZED PENDANT/CEILING MOUNTED PROJECTION SCREEN. CONFIRM EXACT LOCATION WITH OWNER, PRIOR TO ROUGH-IN. E.G. TO INSTALL AND WIRE ALL ASSOCIATED CONTROLS, FOR A COMPLETE WORKING SYSTEM. CONFIRM CONTROL LOCATIONS WITH OWNER, PRIOR TO ROUGH-IN.
12. PROVIDE MINIMUM OF FOUR CONTROL MODULES FOR RECALL, FIREMAN'S HAT, ETC.
13. TAMPER SWITCH IN ELEVATOR MACHINE ROOM AS REQUIRED.
14. PROVIDE CONTROL MODULE TO OPEN DOOR FOR EMERGENCY EGRESS DURING FIRE ALARM EVENT.
15. PROVIDE RECEPTACLE/CIRCUIT FOR NEW ACCESS CONTROL POWER SUPPLY. CONFIRM LOCATION WITH OWNER, PRIOR TO ROUGH-IN.



ALL NEW FIRE ALARM DEVICES SHOWN ON THIS DRAWING ARE TO BE WIRED TO THE NEW FACP IN ELEC ROOM 121 (TYPICAL)

NOTE:
THE EXISTING SECOND FLOOR IS A STRUCTURAL 2-WAY SLAB SPANNING COLUMN LINE TO COLUMN LINE, AND PENETRATIONS AND LOADINGS SHALL BE LIMITED. SEE 9102 FOR NOTES.

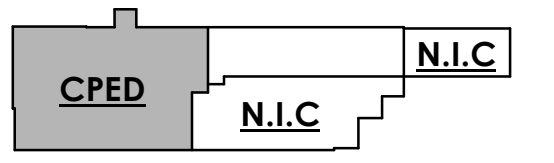
McHenry & Associates Incorporated
Mc&A
 Consulting Engineers est. 1960
 25001 Emory Road, Suite #200
 Warrensville Heights, Ohio 44128
 Phone: 216-292-4696
 Fax: 216-292-5874
 Email: mail@mcHenryassociates.com

City of Kalamazoo - Crosstown Facility
 CPED & KDPS Workplace Renovation
 150 E Crosstown Parkway Kalamazoo MI 49001

Seal:

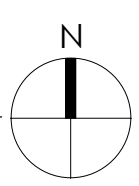
BID Set 08/21/2025
 © 2025, intersect studio, llc
 Project Number: 23-046

**POWER & SYSTEMS
PLAN - UPPER LEVEL
CPED**



KEY PLAN - CPED
 NTS

1 UPPER LEVEL POWER AND SYSTEMS PLAN - CPED
 E202 1/8" = 1'-0"



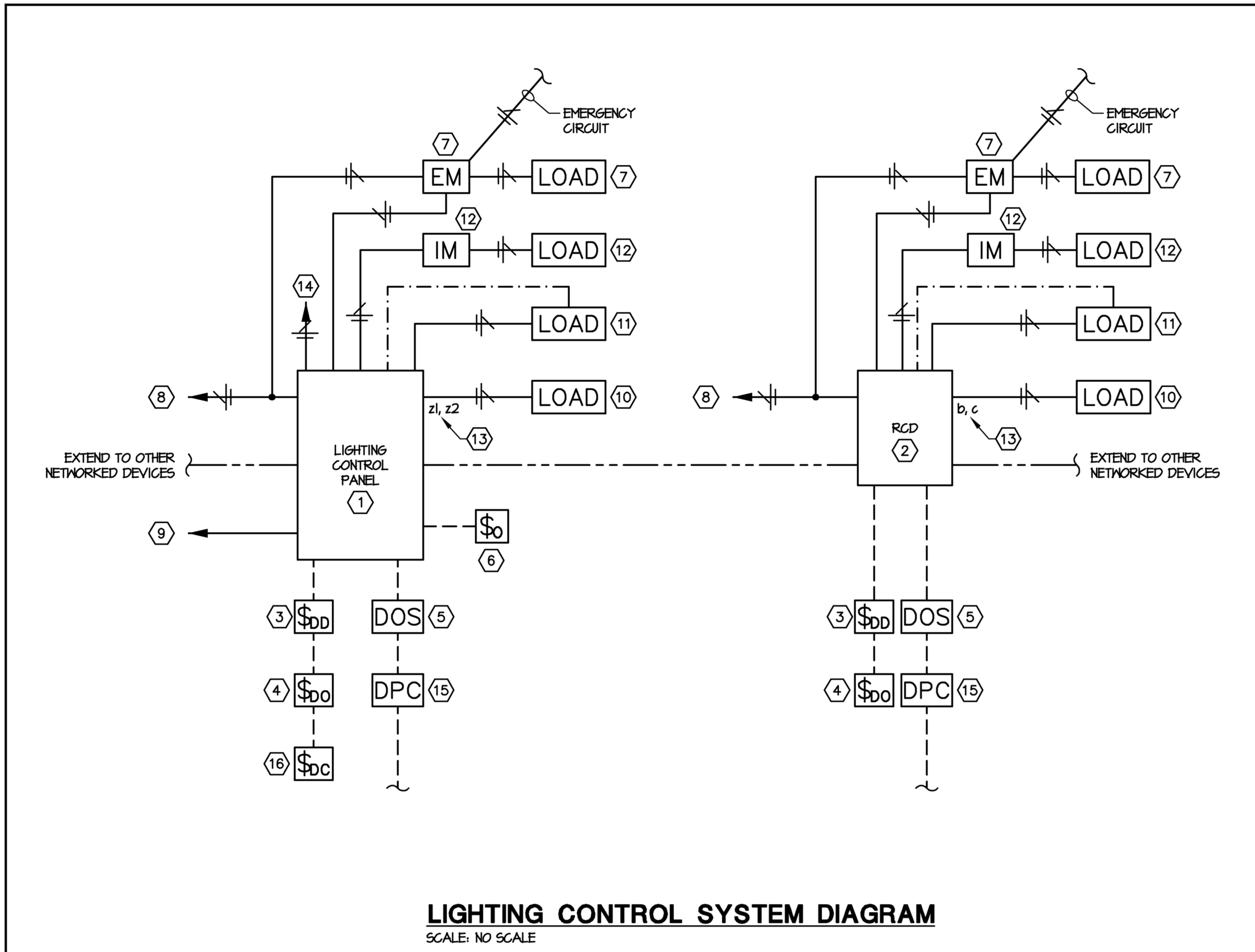
E202

Seal:

BID Set 08/21/2025
 © 2025, intersect studio, llc
 Project Number: 23-046

ELECTRICAL
 DETAILS

E501



WIRING LEGEND

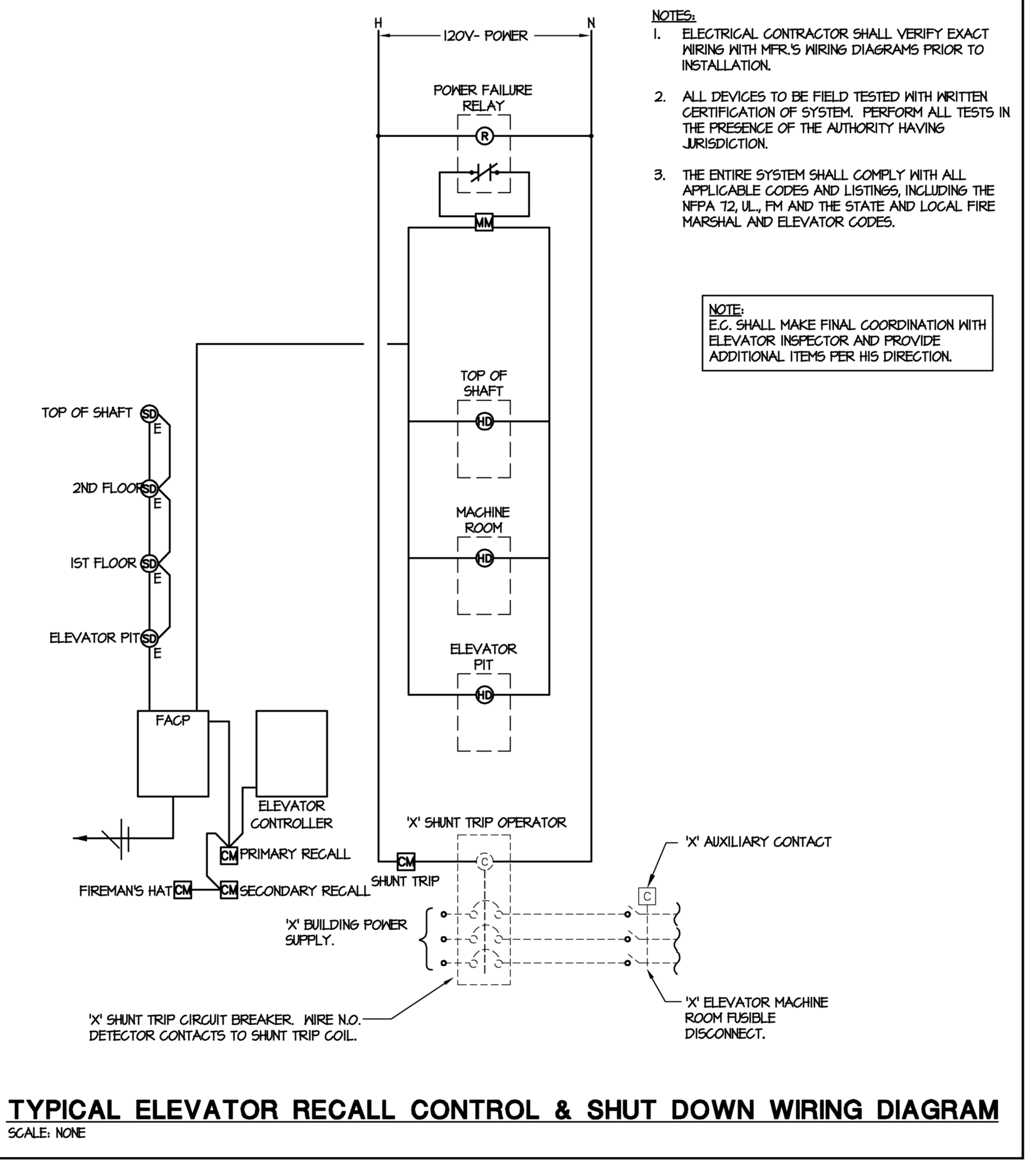
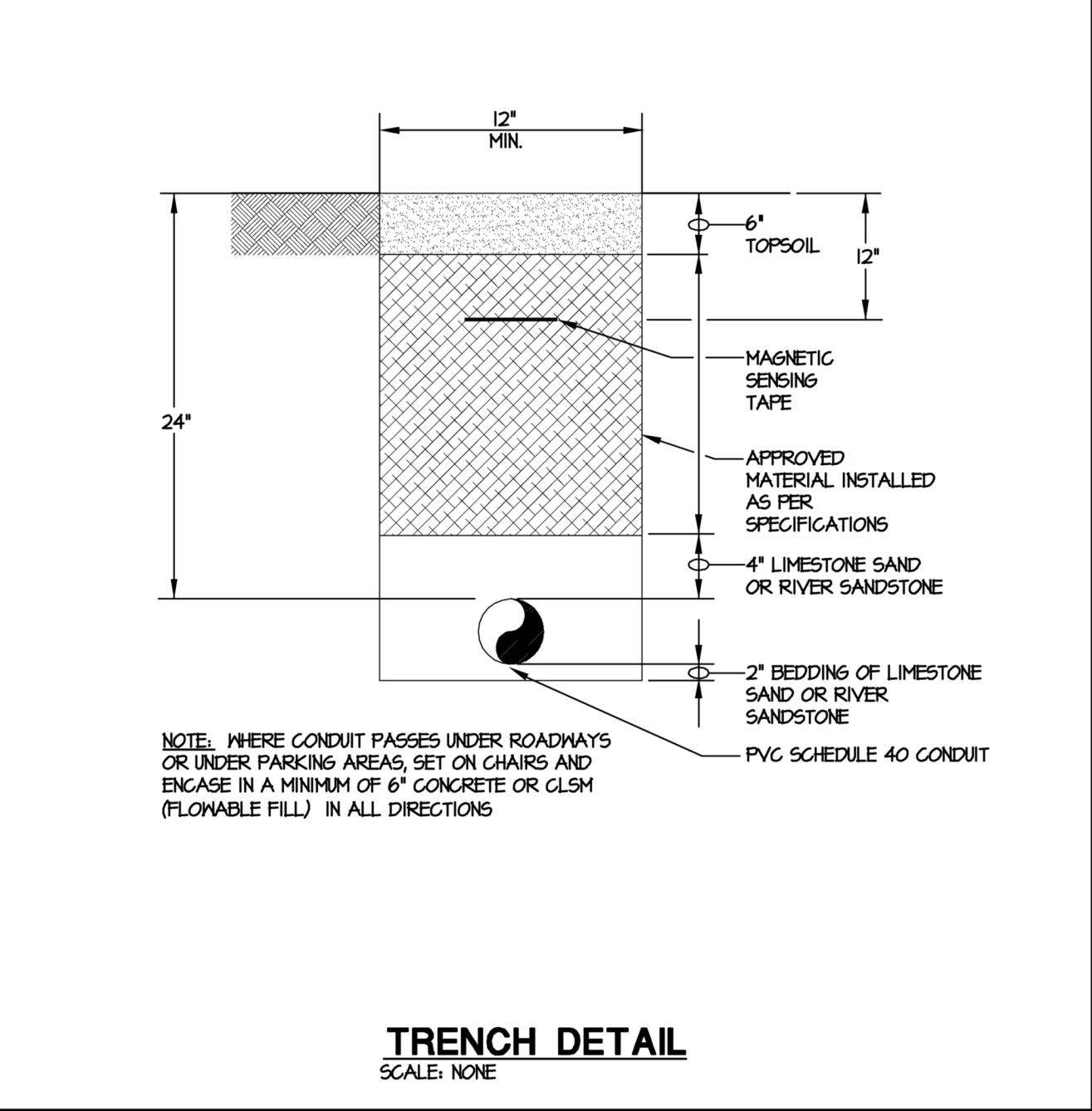
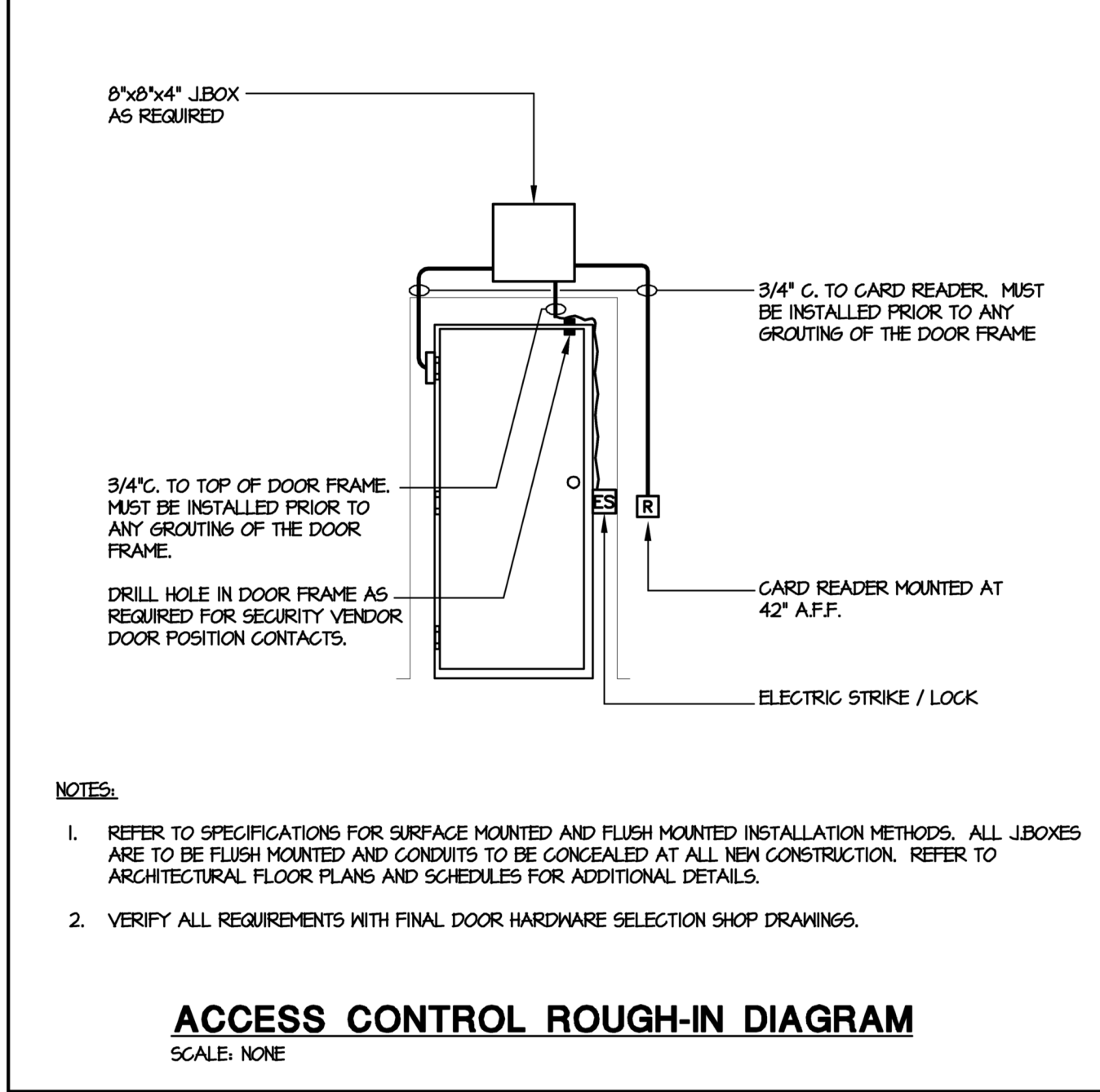
- = 120V OR 277V LINE VOLTAGE WIRING
- - - = SYSTEM NETWORK WIRING PER MANUFACTURER'S REQUIREMENTS. (TYPICALLY CAT 5)
- · - · - = DIGITAL DEVICE WIRING PER MANUFACTURER'S REQUIREMENTS. (TYPICALLY CAT 5)
- · - · - · - = 0-10V CONTROL WIRING PER MANUFACTURER'S REQUIREMENTS.

GENERAL NOTES

- CONTRACTOR IS TO PROVIDE A COMPLETE OPERATIONAL DIGITAL AND NETWORKED LIGHTING CONTROL SYSTEM THAT MEETS THE DESIGN INTENT OUTLINED ON THESE DRAWINGS.
- THIS DIAGRAM IS GENERIC IN NATURE AND DOES NOT REPRESENT QUANTITIES OF DEVICES OR THE ACTUAL SITE SPECIFIC INTERCONNECTION OF DEVICES FOR THIS PROJECT. CONTRACTOR IS TO USE THIS DIAGRAM IN CONJUNCTION WITH THE LIGHTING CONTROL SCHEDULES AND LIGHTING FLOOR PLANS TO CREATE A MANUFACTURER SPECIFIC DESIGN THAT MEETS THE DESIGN INTENT PRESENTED ON THESE DRAWINGS.
- PROVIDE A COMPLETE SET OF SHOP DRAWINGS INCLUDING EQUIPMENT CUT SHEETS, NETWORK TOPOLOGY DIAGRAM AND SYSTEM WIRING DIAGRAMS.
- E.G. SHALL PROVIDE ALL LOW VOLTAGE WIRING/CABLING TYPES AS REQUIRED BY MANUFACTURER, AND PROVIDE ALL REQUIRED TERMINATIONS.
- E.G. SHALL PROVIDE CLASS 2 0-10 VOLT CONTROL WIRING AS REQUIRED.
- REFER TO PLANS FOR DEVICE QUANTITIES.
- INCLUDE COMMISSIONING OF THE SYSTEM. COORDINATE SCHEDULE(S) WITH OWNER REPRESENTATIVE PRESENT.
- DIMMING SET LEVELS SHALL BE MAINTAINED FOLLOWING ON/OFF OPERATIONS, BOTH AUTOMATIC AND MANUAL.
- INCLUDE MINIMUM FOUR (4) HOURS OF TRAINING FOR THE LIGHTING CONTROL SYSTEM TO BE SCHEDULED WITH OWNER.
- PROVIDE 120V CONTROL POWER TO ALL COMPONENTS OF LIGHTING CONTROL SYSTEM REQUIRING POWER.
- INTERIOR PHOTO SENSORS SHALL BE SET TO MAINTAIN THE OWNER REQUESTED FC LEVEL. HORIZONTAL AT 30° AFF. CONFIRM FC LEVEL WITH OWNER, PRIOR TO PROGRAMMING. THE PHOTO SENSORS SHALL MONITOR THE AMBIENT LIGHT IN THE CONTROLLED SPACE AND WORK WITH THE LIGHTING CONTROL PANEL TO MAINTAIN THE DESIGN LIGHT LEVEL.
- ALL LIGHTING CONTROL PANELS AND/OR INDIVIDUAL ROOM CONTROLLERS SHALL BE NETWORKED TO FORM A SINGLE SYSTEM. PROVIDE FRONT END SOFTWARE AND/OR CONNECTION TO OWNER'S BUILDING MANAGEMENT SYSTEM TO ALLOW A SINGLE LOCATION FOR CONTROLLING ALL FUNCTIONS AND PARAMETERS.

CODED NOTES

- LIGHTING CONTROL PANEL SHALL MEET THE FOLLOWING SPECIFICATIONS:
 - BASIS OF DESIGN IS CRESTRON GREEN LIGHT - NO EXCEPTIONS.
 - PANEL SHALL BE PROGRAMMABLE VIA A WEB BROWSER PORTAL. NETWORK CONNECTION SHALL BE PROVIDED.
 - LOADS SHALL BE 120 OR 277 VOLT, 1 PHASE.
 - NEMA 1 ENCLOSURE
 - RELAYS SHALL BE SINGLE POLE LATCHING WITH INTEGRAL OVERRIDE BUTTON. RELAYS RATED FOR 30 AMPS AT 120/277V VOLTS, 18,000 AIC, 16 AMPS FOR ELECTRONIC BALLASTS AND LED DRIVERS.
 - DOUBLE POLE RELAYS SHALL BE 20 AMPS AT 208V, 240V AND 480V (14,000 AIC).
 - LISTED TO UL916 AND UL924
 - 5 YEAR LIMITED WARRANTY
 - INCLUDE RELAY QUANTITIES AS REQUIRED TO MEET THE ZONING INDICATED ON THE CONTROL SCHEDULES. INCLUDE 10% SPARE RELAYS.
 - PROVIDE CAPABILITY FOR DIMMING AS LISTED ON THE CONTROL SCHEDULES. PROVIDE ACCESSORY MODULES AS NECESSARY TO ACCOMMODATE DIMMING PROTOCOLS.
- DIGITAL ROOM CONTROLLER SHALL MEET THE FOLLOWING SPECIFICATIONS:
 - BASIS OF DESIGN IS CRESTRON GREEN LIGHT - NO EXCEPTIONS.
 - INPUT: SINGLE FEED 120/277VAC, 20A MAX, 60 HZ
 - OUTPUT: 20A TUNGSTEN (120V ONLY), 20A MAGNETIC BALLAST, 16A ELECTRONIC BALLAST, 1HP MOTOR AT 120V, 3/4 HP AT 277V
 - NETWORKABLE WITH CLASS 2 CONNECTIONS, MANUFACTURER SPECIFIC PROTOCOL
 - DIMMING OUTPUT FOR 0-10V AS REQUIRED
 - CONFIGURABLE WITH INTERFACE MODULES FOR OTHER DIMMING PROTOCOLS INCLUDING ELV, MLV, AND FORWARD PHASE
 - FLEMN RATED
 - LISTED TO UL916
 - 5 YEAR LIMITED WARRANTY
- DIGITAL SWITCH FOR ON/OFF & DIMMING CONTROL OF ZONE QUANTITIES INDICATED ON SCHEDULES.
- DIGITAL SWITCH FOR ON/OFF CONTROL OF ZONE QUANTITIES INDICATED ON SCHEDULES.
- DIGITAL INFRARED CEILING VACANCY/OCCUPANCY SENSOR. PROVIDE TYPE AND QUANTITY NECESSARY TO COVER THE ASSOCIATED AREA SHOWN ON PLAN.
- DIGITAL ON/OFF 2 BUTTON SWITCH FOR OVERRIDE CONTROL OF LIGHTING CONTROL SYSTEM. SWITCH TO BE PROGRAMMED TO OVERRIDE CURRENT ON/OFF STATUS OF ALL TRANSITIONAL ZONES INCLUDING CORRIDORS, VESTIBULES, ETC. TO ALLOW FOR NAVIGATING THE BUILDING AFTER HOURS.
- FIXTURES THAT ARE SHADED OR MARKED EM ARE TO BE FED BY A LIFE SAFETY BRANCH GENERATOR CIRCUIT. PROVIDE A UL424 LISTED TRANSFER DEVICE THAT WILL SWITCH TO GENERATOR POWER DURING A NORMAL POWER LOSS AND BRING TO FULL BRIGHTNESS. TRANSFER DEVICE SHALL BE HUBBELL RUL424EPC-UNV FOR NON-DIMMED LOADS AND RUL424EPCD-UNV FOR DIMMED LOADS.
- LIGHTING CIRCUIT LINE VOLTAGE HOMERUN. REFERENCE LIGHTING CONTROL SCHEDULES FOR VOLTAGE, PANEL AND CIRCUIT NUMBERS.
- PROVIDE ETHERNET CONNECTION TO LIGHTING CONTROL PANEL FOR OFF SITE PROGRAMMING AND VISIBILITY.
- LIGHTING OR RECEPTACLE LOAD WITH ON/OFF ONLY CONTROL PER LIGHTING CONTROL SCHEDULES.
- LIGHTING LOAD WITH ON/OFF AND DIMMING CONTROL WITH 0-10V PROTOCOL.
- LIGHTING LOAD WITH ON/OFF AND DIMMING CONTROL WITH OTHER PROTOCOL SUCH AS ELV, MLV OR FORWARD PHASE. PROVIDE INTERFACE MODULES AS REQUIRED TO ACCOMMODATE DIMMABLE LOAD.
- ZONE DESIGNATIONS SHOWN ON PLAN FOR ROOM CONTROLLERS, LOADS & DIGITAL DEVICES. TO DETERMINE CONTROL SEQUENCE REQUIREMENTS, REFERENCE THE ROOMSPACES REFERENCED ON THE APPROPRIATE LIGHTING CONTROL SCHEDULE AND THEN USE THE ZONE DESIGNATIONS TO DIFFERENTIATE ZONES WITHIN EACH ROOM/SPACE.
- PROVIDE 120V CONTROL CIRCUIT FOR LIGHTING CONTROL PANEL.
- DIGITAL PHOTOCELL. PROVIDE INTERIOR OR EXTERIOR PHOTOCELL DEVICE BASED ON LOCATION INDICATED ON PLANS.
- DIGITAL TOUCHSCREEN CONTROLLER FOR ON/OFF, DIMMING CONTROL & SCENE SELECTION OF ZONE QUANTITIES INDICATED ON SCHEDULES. CONFIGURABLE FOR UP TO 16 ZONES (ON/OFF OR ON/OFF/DIMMING) / PRESET SCENES.



NOTES:

- ELECTRICAL CONTRACTOR SHALL VERIFY EXACT WIRING WITH MFR.'S WIRING DIAGRAMS PRIOR TO INSTALLATION.
- ALL DEVICES TO BE FIELD TESTED WITH WRITTEN CERTIFICATION OF SYSTEM. PERFORM ALL TESTS IN THE PRESENCE OF THE AUTHORITY HAVING JURISDICTION.
- THE ENTIRE SYSTEM SHALL COMPLY WITH ALL APPLICABLE CODES AND LISTINGS, INCLUDING THE NFPA 72, UL, FM AND THE STATE AND LOCAL FIRE MARSHAL AND ELEVATOR CODES.

NOTE:
 E.G. SHALL MAKE FINAL COORDINATION WITH ELEVATOR INSPECTOR AND PROVIDE ADDITIONAL ITEMS PER HIS DIRECTION.

LIGHTING FIXTURE SCHEDULE

TYPE	DESCRIPTION	MOUNTING	VOLTS	VA	DELIVERED LUMENS	CRI	CCT	MANUFACTURER	CATALOG NUMBER	DRIVER TYPE	EQUIVALENT
A2	LED 2x2 ARCHITECTURAL TROFFER WITH CENTER BASKET AND CURVED MATTE REFLECTOR	RECESSED GRID	120/277	24 VA	3240	90	4000	LITHONIA	STAK-2X2-3000LM-90CRI-40K-COL-MINI-ZT-MVOLT	0-10V DIMMING TO 1%	HE WILLIAMS METALLUX
AA	LED 2x4 ARCHITECTURAL TROFFER WITH CENTER BASKET AND CURVED MATTE REFLECTOR	RECESSED GRID	120/277	24 VA	3269	90	4000	LITHONIA	STAK-2X4-3000LM-90CRI-40K-COL-MINI-ZT-MVOLT	0-10V DIMMING TO 1%	HE WILLIAMS METALLUX
AB	SAME AS FIXTURE TYPE 'AA' EXCEPT 4000 LUMENS	RECESSED GRID	120/277	33 VA	4255	90	4000	LITHONIA	STAK-2X4-4000LM-90CRI-40K-COL-MINI-ZT-MVOLT	0-10V DIMMING TO 1%	HE WILLIAMS METALLUX
AC	SAME AS FIXTURE TYPE 'AA' EXCEPT 5000 LUMENS	RECESSED GRID	120/277	42 VA	5428	90	4000	LITHONIA	STAK-2X4-5000LM-90CRI-40K-COL-MINI-ZT-MVOLT	0-10V DIMMING TO 1%	HE WILLIAMS METALLUX
AD	SAME AS FIXTURE TYPE 'AA' EXCEPT 6000 LUMENS	RECESSED GRID	120/277	50 VA	6225	90	4000	LITHONIA	STAK-2X4-6000LM-90CRI-40K-COL-MINI-ZT-MVOLT	0-10V DIMMING TO 1%	HE WILLIAMS METALLUX
B2A	4" APERTURE RECESSED LED LINEAR FIXTURE WITH FLUSH LENS AND WHITE FINISH, LENGTH PER PLANS. WATTS SHOWN ARE PER 1' LENGTH.	RECESSED	277	5 VA	479 PER FOOT	90	4000	FINELITE	HP-4-R-D-xx-B-940-F-96LG-277-SC-FC-1%-C2T-SW	0-10V DIMMING TO 1%	MARK ARCHITECTURAL PRECISION ARCHITECTURAL LIGHTING
B2B	SAME AS FIXTURE TYPE 'B2A' EXCEPT HIGH OUTPUT	RECESSED	277	7 VA	725 PER FOOT	90	4000	FINELITE	HP-4-R-D-xx-B-940-F-96LG-277-SC-FC-1%-C2T-SW	0-10V DIMMING TO 1%	MARK ARCHITECTURAL PRECISION ARCHITECTURAL LIGHTING
BA	4" APERTURE SUSPENDED LED DIRECT/INDIRECT LINEAR FIXTURE WITH FLUSH LENS AND WHITE FINISH, LENGTH PER PLANS. WATTS SHOWN ARE PER 1' LENGTH.	PENDANT 9'-0" AFF	277	8 VA	428 PER FOOT UP 477 PER FOOT DOWN	90	4000	FINELITE	HP-4-P-ID-xx-S-B-940-F-F-96LG-277-SC-FC-1%-C2T-FE-SW	0-10V DIMMING TO 1%	MARK ARCHITECTURAL PRECISION ARCHITECTURAL LIGHTING
BB	SAME AS FIXTURE TYPE 'BA' EXCEPT HIGH DOWNLIGHT OUTPUT	PENDANT 9'-0" AFF	277	11 VA	428 PER FOOT UP 721 PER FOOT DOWN	90	4000	FINELITE	HP-4-P-ID-xx-S-H-940-F-F-96LG-277-SC-FC-1%-C2T-FE-SW	0-10V DIMMING TO 1%	MARK ARCHITECTURAL PRECISION ARCHITECTURAL LIGHTING
C2A	4" SQUARE FLANGELESS RECESSED LED DOWNLIGHT WITH CLEAR METALIZED TRIM, MATTE DIFFUSE FINISH AND MEDIUM DISTRIBUTION	RECESSED	120/277	7 VA	773	90	4000	GOTHAM	IV04SQ-D-07LM-40K-90CRI-MD-MINI-MVOLT-ZT-NCH-AR-LD-FL	0-10V DIMMING TO 1%	HE WILLIAMS PORTFOLIO
C2B	SAME AS FIXTURE TYPE 'C2A' EXCEPT 1500 LUMENS	RECESSED	120/277	15 VA	1562	90	4000	GOTHAM	IV04SQ-D-15LM-40K-90CRI-MD-MINI-MVOLT-ZT-NCH-AR-LD-FL	0-10V DIMMING TO 1%	HE WILLIAMS PORTFOLIO
C2C	SAME AS FIXTURE TYPE 'C2A' EXCEPT 2500 LUMENS	RECESSED	120/277	27 VA	2571	90	4000	GOTHAM	IV04SQ-D-25LM-40K-90CRI-MD-MINI-MVOLT-ZT-NCH-AR-LD-FL	0-10V DIMMING TO 1%	HE WILLIAMS PORTFOLIO
CA	4" RECESSED LED DOWNLIGHT WITH CLEAR ANODIZED TRIM, MATTE DIFFUSE FINISH AND MEDIUM DISTRIBUTION	RECESSED	120/277	7 VA	735	90	4000	GOTHAM	IV04-D-07LM-40K-90CRI-MD-MINI-MVOLT-ZT-NCH-P-AR-LD-F	0-10V DIMMING TO 1%	HE WILLIAMS PORTFOLIO
CB	SAME AS FIXTURE TYPE 'CA' EXCEPT 1500 LUMENS	RECESSED	120/277	15 VA	1486	90	4000	GOTHAM	IV04-D-15LM-40K-90CRI-MD-MINI-MVOLT-ZT-NCH-P-AR-LD-F	0-10V DIMMING TO 1%	HE WILLIAMS PORTFOLIO
CC	SAME AS FIXTURE TYPE 'CA' EXCEPT 2500 LUMENS	RECESSED	120/277	27 VA	2447	90	4000	GOTHAM	IV04-D-25LM-40K-90CRI-MD-MINI-MVOLT-ZT-NCH-P-AR-LD-F	0-10V DIMMING TO 1%	HE WILLIAMS PORTFOLIO
CW	4" RECESSED LED DOWNLIGHT WITH CLEAR ANODIZED TRIM, MATTE DIFFUSE FINISH, MEDIUM DISTRIBUTION AND WET LOCATION LISTED	RECESSED	120/277	10 VA	991	90	4000	GOTHAM	IV04-D-10LM-40K-90CRI-MD-MINI-MVOLT-ZT-NCH-WL-P-AR-LD-F	0-10V DIMMING TO 1%	HE WILLIAMS PORTFOLIO
D	36" DIAMETER LED SURFACE MOUNTED FIXTURE WITH MATTE WHITE FINISH	SURFACE	120/277	85 VA	7905	90	4000	OCL ARCHITECTURAL LIGHTING	GL2-C1NA-36-MW-MWP-LED2/940X-UNV-DM1	0-10V DIMMING TO 1%	NONE
D2	DECORATIVE LED PENDANT FIXTURE WITH NATURAL WOOD VENER FINISH	PENDANT	120/277	42 VA	3300	90	3000	ACCORD LIGHTING	FRAME ACCORD CEILING MOUNT #5084LED	0-10V DIMMING	NONE
D3	DECORATIVE LED PENDANT FIXTURE WITH BLACK FINISH	PENDANT	120/277	200 VA	-	90	RGBW & 3500	DELRAY	UDCS-K-RGBW-SR-DMX	DMX	NONE
E	DECORATIVE LED CYLINDER WITH FINISH AS SELECTED BY ARCHITECT	PENDANT	277	56 VA	2085	90	4000	TMS LIGHTING	3830TE-56LED-DLED-xc-40K-277-Fxx-DIM L	0-10V DIMMING	NONE
F	SURFACE MOUNTED LED FIXTURE WITH WHITE FINISH	SURFACE	120/277	17 VA	2000	90	3000	BOCK LIGHTING	PIANETA-S-WH-10-EG1/LVGV1-2000-30K	0-10V DIMMING	NONE
H	DECORATIVE LED PENDANT WITH BRONZE FINISH	PENDANT	120/277	8 VA	866	90	3000	ZANEEN LIGHTING	OSCURA MAX #D141225-3000-BRZ W/ 0-10V DIMMING	0-10V DIMMING	NONE
J	VANITY WALL MOUNT LED FIXTURE WITH BRUSHED NICKEL FINISH	WALL	120/277	18 VA	1304	90	3000	LITHONIA	FMVCSL-24N-MVOLT-30K-90CRI-BN	NON-DIMMING	NONE
K	4" LED NARROW STRIP FIXTURE WITH ROUND ACRYLIC LENS	CABLE	120/277	33 VA	4867	80	4000	HE WILLIAMS	75R-4-L50/840-DRV-UNV	NON-DIMMING	LITHONIA METALLUX
L	DECORATIVE LED PENDANT FIXTURE WITH BLACK FINISH	PENDANT	120/277	70 VA	10733	80	4000	LSI INDUSTRIES	OPS-PD-10L-SQ-UNV-40K8-BLK-EXT	0-10V DIMMING	NONE
M	LUMINOUS 190 SQ.IN. (1.32 SQ.FT.) STANDARD-OUTPUT LED PANEL WITH QUANTITY OF 120/277V-24V 0-10V DIMMABLE POWER SUPPLIES AS REQUIRED	RECESSED	120/277	8 VA	575 PER SQ.FT.	90	4100	OMNI LIGHT	QBE-41-SQ-19x10 (PANEL) APO-xx-E-24 (POWER SUPPLY)	0-10V DIMMING	NONE
P	6" APERTURE RECESSED LED LINEAR FIXTURE WITH FLUSH LENS, BRONZE FINISH, AND WET LOCATION LISTED, LENGTH PER PLANS. WATTS SHOWN ARE PER 1' LENGTH.	RECESSED	120/277	9 VA	832 PER FOOT	80	4000	PINNACLE LIGHTING	WET-840H0-xx-xxx-FL(F)-U-FSD-1-BR	0-10V DIMMING TO 1%	MARK ARCHITECTURAL PRECISION ARCHITECTURAL LIGHTING
Q	INDUSTRIAL 68" CEILING FAN WITH WALL MOUNTED CONTROL AND MATTE BLACK FINISH	PENDANT	120	90 VA	-	-	-	RP LIGHTING	Arctic II #1086W-MBK-MBK-WC	-	NONE
R	LED WALL SCONCE WITH VINTAGE BRASS & COGNAC LEATHER FINISH	WALL	120	16 VA	380	90	2700	ALORA LIGHTING	VALUSE #VW307919VBCL	DIMMABLE	NONE
SA	14" LED SITE LIGHT ALUMINUM COLUMN WITH BLACK FINISH - IP66 RATED	POST	120/277	65 VA	3810	-	4000	BULLARD BOLLARDS	BB-C221-BL-BH7-BW2-SH7-AL-K40-BL-TB-D-BW-NON-LSC65-ITF	NON-DIMMING	CYCLONE LIGHTING
SB	LED SITE LIGHTING LANDSCAPE MEDIUM FLOOD LIGHT WITH FINISH AS SELECTED BY ARCHITECT - WET LOCATION LISTED	GROUND	120/277	19 VA	1188	80	4000	VISTA PRO	1043Y-xx-MF-40-F-MV-ND	NON-DIMMING	NONE
SC	DECORATIVE LED EXTERIOR WALL SCONCE WITH SATIN BLACK FINISH - IP66 RATED	WALL	277	10 VA	450 PER FOOT	-	4000	LUMCA	LU-WPS-A-00-B-40-C-00-277-BK	0-10V DIMMING	NONE
SD	EXTERIOR LED WALLPACK WITH CLEAR TEMPERED GLASS LENS, PHOTOCELL & STANDARD FINISH AS SELECTED BY ARCHITECT - IP65 RATED	WALL	277	16 VA	1921	80	4000	HE WILLIAMS	VWMH-L17/840-TL-xxx-CGL-PC-DIM-277	0-10V DIMMING	LITHONIA METALLUX
T	DECORATIVE LED PENDANT FIXTURE WITH CAVA FINISH	PENDANT	120/277	18 VA	1885	90	4000	CERNO GROUP	Volo 18 pendant part # 06-360-C-40-P1	0-10V DIMMING	NONE
U	DECORATIVE INCANDESCENT (40W MAX) WALL SCONCE WITH LED REPLACEMENT LAMP	WALL	120	5 VA	450	92	3500	BIRCHLANE	DRAKE WALL SCONCE #8000582092 LAMP: SATCO S12468, A19 LED FILAMENT DIMMABLE, E26 BASE, SW	DIMMABLE	NONE
V	DECORATIVE LED PENDANT FIXTURE WITH RUBY RED FINISH	PENDANT	120/277	39 VA	4567	90	4000	SPECTRUM LIGHTING	WS3617GV-55L-40HK-DO10X-xxx-FCI-RD	0-10V DIMMING TO 1%	NONE
W	DECORATIVE LED PENDANT FIXTURE WITH FINISH AS SELECTED BY ARCHITECT	PENDANT 8'-6" AFF	120	158 VA	5065	90	3000	KUZCO	VEGA PENDANT #MP10305-xx	ELV DIMMING	NONE
X1	THERMOPLASTIC LED SINGLE FACE EXIT SIGN WITH RED LETTERS AND WHITE HOUSING	UNIVERSAL	120/277	2 VA	-	-	-	LITHONIA	LQM-S-W-3-R-120/277	-	HE WILLIAMS SURE-LITES
X2	THERMOPLASTIC LED DOUBLE FACE EXIT SIGN WITH RED LETTERS AND WHITE HOUSING	UNIVERSAL	120/277	2 VA	-	-	-	LITHONIA	LQM-S-W-3-R-120/277	-	HE WILLIAMS SURE-LITES
Y	LED CYLINDER TRACK HEAD WITH DISTRIBUTION AND FINISH AS SELECTED BY ARCHITECT - PROVIDE LENGTH OF 120/277V 0-10V DIMMABLE TRACK AS SHOWN ON ARCHITECTURAL PLANS	TRACK	120/277	30 VA	2000	90	4000	ELITE- FUSION LIGHTING	FG-T4-3-xx-40K-90-xx-xx (TRACK HEAD) FG-CM/SM-xx (TRACK)	0-10V DIMMING TO 1%	NONE
Z	2" RECESSED LED ADJUSTABLE DOWNLIGHT WITH WHITE TRIM AND FLANGE	RECESSED	120/277	15 VA	1146	90	3500	CREATIVE SYSTEMS LIGHTING	GSD-2-3590-R-WT-WT-30	0-10V DIMMING	NONE

LIGHTING FIXTURE SCHEDULE NOTES

- CONFIRM ALL FIXTURE VOLTAGES WITH CIRCUITING ON PLAN.
- MANUFACTURER TO VERIFY FIXTURE CATALOG NUMBER WITH THE DESCRIPTION OF THE FIXTURE AND CIRCUITING ON THE PLANS.
- ALL EXIT SIGNS TO HAVE RED LETTERS WITH 8" X 3/4" LETTERS AND BE WIRED TO THE LIFE SAFETY BRANCH OF THE EMERGENCY SYSTEM.
- ALL RECESSED DOWN LIGHTS ARE TO HAVE INTEGRAL THERMAL PROTECTION.
- ALL ACRYLIC LENSES ARE TO BE 1/2" THICK MINIMUM.
- REFER TO ARCHITECTURAL ELEVATIONS FOR CONFIRMATION OF MOUNTING HEIGHTS OF ALL LIGHT FIXTURES.
- CONTRACTOR SHALL PROVIDE ALL REQUIRED MOUNTING HARDWARE. ALL MOUNTING HARDWARE TO BE PAINTED TO MATCH CEILING OR WALL AS DIRECTED.
- ALL LUMINAIRE TRIM COLORS SHALL BE SUBMITTED TO ARCHITECT FOR APPROVAL. DO NOT ORDER FIXTURES WITHOUT APPROVED COLORS.
- ALL MOUNTING HEIGHTS OF LIGHT FIXTURES INDICATED ARE TO BE MEASURED FROM THE BOTTOM OF THE LIGHT FIXTURE TO THE FINISHED FLOOR UNLESS NOTED OTHERWISE.
- CONTRACTOR SHALL CONFIRM COMPATIBILITY OF ALL LED REPLACEMENT LAMPS WITH SPECIFIED LIGHTING CONTROLS, PRIOR TO ORDERING.
- CONTRACTOR SHALL CONFIRM ALL STEM LENGTHS AND SPECIAL MOUNTING DETAILS WITH ARCHITECT.

McHenry & Associates Incorporated

Mc&A
Consulting Engineers est. 1960
25001 Emery Road, Suite #200
Warrensville Heights, Ohio 44128
Phone: 216-292-4696
Fax: 216-292-5874
Email: mail@mchenryassociates.com

City of Kalamazoo - Crosstown Facility
CPED & KDPS Workplace Renovation
150 E Crosstown Parkway Kalamazoo MI 49001

Seal:



BID Set 08/21/2025

© 2025, intersect studio, llc
Project Number: 23-046

ELECTRICAL SCHEDULES

E601

LIGHTING CONTROL PANEL 'LCP1'

ROOM NAME	CIRCUIT	ZONE	LOCAL MANUAL ON/OFF CONTROL	LOCAL DIMMING CONTROL	RECEPTACLE CONTROL	DAYLIGHTING (INTERIOR PHOTOCELL)	TIMELOCK	OCC SENSOR PARTIAL OFF (AFTER 30 MINS)	VACANCY DETECTION (MANUAL ON)	EXTERIOR PHOTO SENSOR CONTROL	EMERGENCY LIGHTING CONTROL	LIGHT FIXTURE DIMMING TYPE
ADMIN 215 / MEET 218	RP38-10	21			X		X					NONE
BLDG TRADES OFFICE 149	RP2-35	21			X		X					NONE
BREAK 126	RP1-28	21			X		X					NONE
BRIEFING 258	RP3B-6	21			X		X					NONE
BUILDING TRADES 162	RP1B-1	21			X		X					NONE
BUILDING TRADES 162	RP1B-3	21			X		X					NONE
BUILDING TRADES 162	RP1B-5	21			X		X					NONE
BUILDING TRADES 162	RP1B-7	21			X		X					NONE
BUILDING TRADES 162	RP1B-9	21			X		X					NONE
BUILDING TRADES 162	RP1B-11	21			X		X					NONE
BUILDING TRADES 162	RP1B-13	21			X		X					NONE
CAPTAIN 255	RP3B-16	21			X		X					NONE
CD MANAGER 113	RP1B-4	21			X		X					NONE
CLERK / CASHIER 146	RP2-22	21			X		X					NONE
CLERK / CASHIER 146	RP2-24	21			X		X					NONE
CODE COMPLIANCE 163	RP1B-15	21			X		X					NONE
CODE COMPLIANCE 163	RP1B-17	21			X		X					NONE
CODE COMPLIANCE 163	RP1B-19	21			X		X					NONE
CODE COMPLIANCE 163	RP1B-21	21			X		X					NONE
CODE COMPLIANCE 163	RP1B-23	21			X		X					NONE
CODE COMPLIANCE 163	RP1B-25	21			X		X					NONE
CODE COMPLIANCE OFFICE 150	RP2-37	21			X		X					NONE
COMM DEV 114	RP1B-2	21			X		X					NONE
CONNECT 137	RP1B-10	21			X		X					NONE
CONNECT 169	RP2B-14	21			X		X					NONE
CONNECT 182	RP2-6	21			X		X					NONE
CONNECT 182	RP2-8	21			X		X					NONE
CONNECT 192	RP3-3	21			X		X					NONE
COPY 219	RP3B-12	21			X		X					NONE
COPY-PRINT 115	RP1B-8	21			X		X					NONE
ECON DEC 103	RP2-39	21			X		X					NONE
ECON DEC 103	RP2-41	21			X		X					NONE
EXEC LT 256	RP3B-18	21			X		X					NONE
FINANCE/ADMIN 140	RP1B-20	21			X		X					NONE
FIRE 163 / 167	RP2B-7	21			X		X					NONE
FIRE MARSHALL 151	RP2-10	21			X		X					NONE
FIRE MARSHALL 167 / COURT OFFICER 183	RP2B-9	21			X		X					NONE
FLEET MANAGER 184	RP3-13	21			X		X					NONE
FOCUS 101/ED MANAGER 108	RP2-17	21			X		X					NONE
FOCUS 128	RP1-25	21			X		X					NONE
FOCUS 141/142	RP1B-22	21			X		X					NONE
FOCUS 186 / 187	RP3-28	21			X		X					NONE
FOCUS 194	RP3B-7	21			X		X					NONE
HELP DESK 145	RP2-26	21			X		X					NONE
HELP DESK 145	RP2B-2	21			X		X					NONE
HOTELING 116	RP1-17	21			X		X					NONE
HUDDLE 107/FOCUS 110	RP2-21	21			X		X					NONE
HUDDLE 117	RP1-2	21			X		X					NONE
IT HUDDLE 153	RP1B-41	21			X		X					NONE
IT OFFICE 157	ERP1-14	21			X		X					NONE
LARGE CONNECT 106	RP2-31	21			X		X					NONE
LARGE CONNECT 106	RP2-33	21			X		X					NONE
OFFICE 135/136	RP1B-6	21			X		X					NONE
OFFICE 257 / 259	RP3B-4	21			X		X					NONE
PLAN OFFICE 131	RP1-13	21			X		X					NONE
PLAN OFFICE 132	RP1-15	21			X		X					NONE
PLAN OFFICE 133	RP1-29	21			X		X					NONE
PLAN OFFICE 134	RP1-11	21			X		X					NONE
PLANNING 129	RP1-19	21			X		X					NONE
PLANNING 129	RP1-21	21			X		X					NONE
PLANNING 129	RP1-23	21			X		X					NONE
RECHARGE 260 / DAY ROOM 263	RP3B-37	21			X		X					NONE
REPORT ROOM 261	RP3B-41	21			X		X					NONE
REPORT ROOM 261 / WORK ROOM 262	RP3B-2	21			X		X					NONE
SERVICE COURT 148	RP1B-16	21			X		X					NONE
SERVICE COURT 148	RP1B-18	21			X		X					NONE
SERVICE DESK 153	RP1B-27	21			X		X					NONE
SERVICE DESK 153	RP1B-29	21			X		X					NONE
SERVICE DESK 153	RP1B-31	21			X		X					NONE
SERVICE DESK 153	RP1B-33	21			X		X					NONE
SERVICE DESK 153	RP1B-35	21			X		X					NONE
SERVICE DESK 153	RP1B-37	21			X		X					NONE
SERVICE DESK 153	RP1B-39	21			X		X					NONE
SERVICE DESKS 176/178	RP2B-11	21			X		X					NONE
SERVICE DESKS 176/178	RP2B-13	21			X		X					NONE
SERVICE DESKS 176/178	RP2B-15	21			X		X					NONE
SERVICE DESKS 176/178	RP2B-17	21			X		X					NONE
SERVICE DESKS 176/178	RP2B-21	21			X		X					NONE
SERVICE DESKS 176/178	RP2B-23	21			X		X					NONE
SHIFT COMMAND 216	RP3B-14	21			X		X					NONE
TOWN SQUARE 127	RP1-31	21			X		X					NONE
TOWN SQUARE 127	RP1-35	21			X		X					NONE
WORK CAFE 195	RP3-5	21			X		X					NONE
WORK CAFE 195	RP3B-9	21			X		X					NONE
COMM DEV 114 / HOTELING 116	LP1-3	22	X	X		X	X	X				0-10
PLANNING 129	ELP1-3	23	X	X		X	X	X		X		0-10
PLANNING 129	LP1-3	23	X	X		X	X	X				0-10
MAIN STREET 139	LP1-5	24	X	X		X	X	X				0-10
ECON DEC 103	ELP1-3	25	X	X		X	X	X		X		0-10
ECON DEC 103	LP1-5	25	X	X		X	X	X				0-10
CENTRAL PARK 138	LP1-5	26	X	X		X	X	X				0-10
TOWN SQUARE 127	ELP1-3	27	X	X		X	X	X		X		0-10
TOWN SQUARE 127	LP1-1	27	X	X		X	X	X				0-10
TOWN SQUARE 127	LP1-1	28	X	X		X	X	X				VERIFY
TOWN SQUARE 127	ELP1-3	29	X	X		X	X	X		X		0-10
TOWN SQUARE 127	LP1-1	29	X	X		X	X	X				0-10
COPY-PRINT 115	LP1-3	210	X	X		X	X	X				0-10
CORRIDOR 111	LP1-3	210	X	X		X	X	X				0-10
CORRIDOR 118	LP1-3	210	X	X		X	X	X				0-10
WORK CAFE 195	RP3B-24	211	X	X		X	X	X				VERIFY
WORK CAFE 195	ELP2-1	212	X	X		X	X	X		X		0-10
WORK CAFE 195	LP2-13	212	X	X		X	X	X				0-10
WORK CAFE 195	LP2-13	213	X	X		X	X	X				0-10
WORK CAFE 195	ELP2-1	214	X	X		X	X	X		X		0-10

LIGHTING CONTROL PANEL 'LCP1'

ROOM NAME	CIRCUIT	ZONE	LOCAL MANUAL ON/OFF CONTROL	LOCAL DIMMING CONTROL	RECEPTACLE CONTROL	DAYLIGHTING (INTERIOR PHOTOCELL)	TIMELOCK	OCC SENSOR PARTIAL OFF (AFTER 30 MINS)	VACANCY DETECTION (MANUAL ON)	EXTERIOR PHOTO SENSOR CONTROL	EMERGENCY LIGHTING CONTROL	LIGHT FIXTURE DIMMING TYPE
WORK CAFE 195	LP2-13	214	X	X			X	X	X			0-10
WORK CAFE 195	LP2-13	215	X	X			X	X	X			0-10
CORRIDOR 152	LP1-1	216	X	X			X	X	X			0-10
SERVICE COURT 148	LP1-1	216	X	X			X	X	X			0-10
HELP DESK 145	ELP1-3	217	X	X			X	X	X		X	0-10
HELP DESK 145	LP1-1	217	X	X			X	X	X			0-10
BUILDING/TRADES 144	ELP1-3	218	X	X			X	X	X		X	0-10
BUILDING/TRADES 144	LP1-1	218	X	X			X	X	X			0-10
BUILDING TRADES 162	ELP1-3	219	X	X			X	X	X		X	0-10
BUILDING TRADES 162	LP1-1	219	X	X			X	X	X			0-10
HOTELING 164	ELP1-3	220	X	X			X	X	X		X	0-10
HOTELING 164	LP1-1	220	X	X			X	X	X			0-10
CODE COMPLIANCE 163	ELP1-3	221	X	X			X	X	X		X	0-10
CODE COMPLIANCE 163	LP1-1	221	X	X			X	X	X			0-10
IT 156	ELP1-3	222	X	X			X	X	X		X	0-10
IT 156	LP1-1	222	X	X			X	X	X			0-10
SERVICE DESK 153	ELP1-3	222	X	X			X	X	X		X	0-10
SERVICE DESK 153	LP1-1	222	X	X			X	X	X			0-10
FIRE PREVENTION 163	ELP1-3	223	X	X			X	X	X		X	0-10
FIRE PREVENTION 163	LP1-1	223	X	X			X	X	X			0-10
CORRIDOR 181	LP1-7	224	X	X			X	X	X			0-10
LOBBY 180	ELP1-3	225	X	X			X	X	X		X	0-10
LOBBY 180	LP1-7	225	X	X			X	X	X			0-10
LOBBY 180	ELP1-3	226	X	X			X	X	X		X	0-10
LOBBY 180	LP1-7	226	X	X			X	X	X			0-10
CORRIDOR 181	LP1-7	227	X	X			X	X	X			0-10
LOBBY 180	ELP1-1	228	X	X		<varies>					X	0-10
LOBBY 180	LP1-7	228	X	X		<varies>	X					0-10
LOBBY 180 - SIGN	RP2-12	228					X					NONE
LOBBY 180	ELP1-1	229	X	X							X	0-10
EXTERIOR	ELP2-2	230					X			X	X	<varies>
EXTERIOR	LP2-24	230					X			X	X	NONE
EXTERIOR SIGN	RP2-14	230					X			X		NONE
MAIN STREET 139	RP1B-26	231	X	X			X	X	X			VERIFY
LOBBY 180	LP1-7	232	X	X			X	X	X			0-10
LOBBY 180	ELP3-3	233	X	X		X	X	X	X		X	0-10
LOBBY 180	LP1-7	233	X	X			X	X	X			0-10
SERVICE DESKS 176/178	ELP1-3	234	X	X			X	X	X		X	0-10
SERVICE DESKS 176/178	LP1-7	234	X	X			X	X	X			0-10
DAY ROOM 263	ELP2-9	235	X	X			X	X	X		X	0-10
DAY ROOM 263	LP2-13	235	X	X			X	X	X			0-10
RECHARGE 260	ELP2-9	236	X	X			X	X	X	</		

LIGHTING CONTROL PANEL 'LCP2'

ROOM NAME	CIRCUIT	ZONE	LOCAL MANUAL ON/OFF CONTROL	LOCAL DIMMING CONTROL	RECEPTACLE CONTROL	DAYLIGHTING (INTERIOR PHOTOCCELL)	TIMELOCK	OCC SENSOR PARTIAL OFF (AFTER 30 MINS)	VACANCY DETECTION (MANUAL ON)	EXTERIOR PHOTO SENSOR CONTROL	EMERGENCY LIGHTING CONTROL	LIGHT FIXTURE DIMMING TYPE
CITY HALL OPEN OFFICE 301	RPS-4	z1			X		X					NONE
CITY HALL OPEN OFFICE 301	RPS-6	z1			X		X					NONE
CITY HALL OPEN OFFICE 301	RPS-9	z1			X		X					NONE
CITY HALL OPEN OFFICE 301	RPS-16	z1			X		X					NONE
CITY HALL OPEN OFFICE 301	RPS-23	z1			X		X					NONE
CITY HALL OPEN OFFICE 301	RPS-41	z1			X		X					NONE
CITY HALL OVERFLOW 322	RPS-11	z1			X		X					NONE
CITY HALL OVERFLOW 322	RPS-17	z1			X		X					NONE
CITY HALL OVERFLOW 322	RPS-19	z1			X		X					NONE
CITY HALL OVERFLOW 322	RPS-40	z1			X		X					NONE
OFFICE 30X	RPS-25	z1			X		X					NONE
FITNESS - EQUIPMENT 347	ELP3-5	z2	X	X		X	X	X	X		X	0-10
FITNESS - EQUIPMENT 347	LP3-1	z2	X	X		X	X	X	X			0-10
FITNESS - EQUIPMENT 347	ELP3-5	z3	X	X		X	X	X	X		X	0-10
FITNESS - EQUIPMENT 347	LP3-1	z3	X	X		X	X	X	X			0-10
FITNESS - OPEN 311	ELP3-5	z4	X	X		X	X	X	X		X	0-10
FITNESS - OPEN 311	LP3-1	z4	X	X		X	X	X	X			0-10
DT TRAINING 302	ELP3-5	z5	X	X		X	X	X	X		X	0-10
DT TRAINING 302	LP3-1	z5	X	X		X	X	X	X			0-10
LOBBY 367	LP3-23	z6	X	X			X					0-10
LOBBY 367	ELP3-1	z7	X	X							X	0-10
LOBBY 367	LP3-23	z7	X	X			X					0-10
COMMUNITY ROOM 336 - SIGN	RP6-27	z8	X				X					NONE
COMMUNITY ROOM 336-C	ELP3-3	z9	X	X			X	X	X		X	0-10
COMMUNITY ROOM 336-C	LP3-15	z9	X	X			X	X	X			0-10
COMMUNITY ROOM 336	ELP3-3	z10	X	X			X	X	X		X	0-10
COMMUNITY ROOM 336	LP3-15	z10	X	X			X	X	X			0-10
COMMUNITY ROOM 336-B	ELP3-3	z11	X	X			X	X	X		X	0-10
COMMUNITY ROOM 336-B	LP3-15	z11	X	X			X	X	X			0-10
COMMUNITY ROOM 336-C	ELP3-3	z12	X	X			X	X	X		X	0-10
COMMUNITY ROOM 336	ELP3-3	z13	X	X			X	X	X		X	0-10
COMMUNITY ROOM 336	LP3-15	z13	X	X			X	X	X			0-10
COMMUNITY ROOM 336-B	ELP3-3	z14	X	X			X	X	X		X	0-10
COMMUNITY ROOM 336	LP3-15	z15	X	X			X	X	X			0-10
CITY HALL OPEN OFFICE 301	ELP3-3	z16	X	X		X	X	X	X		X	0-10
CITY HALL OPEN OFFICE 301	LP3-1	z16	X	X		X	X	X	X			0-10
CITY HALL OPEN OFFICE 301	LP3-1	z17	X	X		X	X	X	X			0-10
CITY HALL OPEN OFFICE 301	ELP3-3	z18	X	X			X	X	X		X	0-10
CITY HALL OPEN OFFICE 301	LP3-1	z18	X	X			X	X	X			0-10

SINGLE ROOM LIGHTING CONTROLS - MAIN LEVEL

ROOM NAME	CIRCUIT	ZONE	RECEPTACLE CONTROL	LOCAL MANUAL ON/OFF CONTROL	LOCAL DIMMING CONTROL	DAYLIGHTING (INTERIOR PHOTOCCELL)	OCC SENSOR FULL OFF (AFTER 30 MINS)	OCC SENSOR PARTIAL OFF (AFTER 30 MINS)	BAS INTEGRATION	VACANCY DETECTION (MANUAL ON)	EMERGENCY LIGHTING CONTROL	LIGHT FIXTURE DIMMING TYPE
CORRIDOR 214	LP2-13	bb						X				0-10
CORRIDOR 119	LP1-3	c						X				0-10
VENDING 123	LP1-3	c						X				0-10
BRIEFING 258	ELP2-9	cc		X	X	X	X			X	X	0-10
BRIEFING 258	LP2-13	cc		X	X	X	X			X		0-10
CLERK / CASHIER 146	ELP1-3	d		X	X		X			X	X	0-10
CLERK / CASHIER 146	LP1-1	d		X	X		X			X		0-10
WOMEN'S 174	ELP1-3	dd					X				X	NONE
WOMEN'S 174	LP1-7	dd					X					NONE
CLERK / CASHIER 146	LP1-1	e		X	X		X			X		0-10
CORRIDORS 185/196	LP2-13	ee						X				0-10
DIRECTOR 100	ELP1-3	f		X	X		X			X	X	0-10
DIRECTOR 100	LP1-5	f		X	X		X			X		0-10
CONNECT 137	ELP1-3	ff		X	X		X			X	X	0-10
Huddle 117	ELP1-3	g		X	X		X			X	X	0-10
CONNECT 137	LP1-3	gg		X	X		X			X		0-10
LARGE CONNECT 106	LP1-5	h		X	X		X			X		0-10
CONNECT 137	LP1-3	hh		X	X		X			X		0-10
LARGE CONNECT 106	ELP1-3	i		X	X		X			X	X	0-10
LARGE CONNECT 106	LP1-5	i		X	X		X			X		0-10
CONNECT 192	ELP2-9	ii		X	X		X			X	X	0-10
CONNECT 192	LP2-13	ii		X	X		X			X		0-10
LARGE CONNECT 106	ELP1-3	j		X	X		X			X	X	0-10
LARGE CONNECT 106	LP1-5	j		X	X		X			X		0-10
RECORDS 177	ELP1-3	k		X	X		X			X	X	0-10
RECORDS 177	LP1-7	k		X	X		X			X		0-10
STORAGE 147	LP1-1	m		X			X			X		NONE
WOMEN'S 122	ELP1-3	n					X				X	NONE
WOMEN'S 122	LP1-3	n					X					NONE
MEN'S 124	ELP1-3	o					X				X	NONE
MEN'S 124	LP1-3	o					X					NONE
BREAK 126	ELP1-3	p		X	X		X			X	X	0-10
BREAK 126	LP1-3	p		X	X		X			X		0-10
CONNECT 182	ELP1-3	q		X	X		X			X	X	0-10
CONNECT 182	LP1-5	q		X	X		X			X		0-10
CONNECT 182	LP1-5	r		X	X		X			X		0-10
MEN'S 173	ELP1-3	s					X				X	NONE
MEN'S 173	LP1-7	s					X					NONE
KDPS WAITING AREA 168	LP2-13	t		X	X			X		X		0-10
KDPS WAITING AREA 168	ELP2-1	u		X	X			X		X	X	0-10
KDPS WAITING AREA 168	LP2-13	u		X	X			X		X		0-10
CORRIDOR 161	LP1-1	v						X				0-10
MEN'S 253	ELP2-9	y					X				<varies>	NONE
MEN'S 253	LP2-13	y					X					NONE
WOMEN'S 251	ELP2-9	z					X				X	NONE
WOMEN'S 251	LP2-13	z					X					NONE

SINGLE ROOM LIGHTING CONTROLS - UPPER LEVEL

ROOM NAME	CIRCUIT	ZONE	RECEPTACLE CONTROL	LOCAL MANUAL ON/OFF CONTROL	LOCAL DIMMING CONTROL	DAYLIGHTING (INTERIOR PHOTOCCELL)	OCC SENSOR FULL OFF (AFTER 30 MINS)	OCC SENSOR PARTIAL OFF (AFTER 30 MINS)	BAS INTEGRATION	VACANCY DETECTION (MANUAL ON)	EMERGENCY LIGHTING CONTROL	LIGHT FIXTURE DIMMING TYPE
FURNITURE STORAGE 341	LP3-23	c		X			X			X		NONE
BROADCASTING 339	ELP3-3	d		X	X		X			X	X	0-10
BROADCASTING 339	LP3-23	d		X	X		X			X		0-10
CATERING 33X	ELP3-5	e		X	X		X			X	X	0-10
CATERING 33X	LP3-23	e		X	X		X			X		0-10
MEN 368	ELP3-3	f					X				X	NONE
MEN 368	LP3-23	f					X					NONE
WOMEN 369	ELP3-3	g					X				X	NONE
WOMEN 369	LP3-23	g					X					NONE
CORRIDOR 365	LP3-27	h						X				0-10
CORRIDOR 330	LP3-27	i						X				0-10
CORRIDORS 303/312	LP3-27	j						X				0-10
CORRIDOR 323	LP3-27	k						X				0-10

McHenry & Associates Incorporated
MC&A
 Consulting Engineers est. 1960
 25001 Emery Road, Suite #200
 Warrensville Heights, Ohio 44128
 Phone: 216-292-4696
 Fax: 216-292-5874
 Email: mail@mchenryassociates.com

City of Kalamazoo - Crosstown Facility
 CPED & KDPS Workplace Renovation
 150 E Crosstown Parkway Kalamazoo MI 49001

Seal:

BID Set 08/21/2025
 © 2025, intersect studio, llc
 Project Number: 23-046

ELECTRICAL SCHEDULES

E603

LIGHTING CONTROL NOTES:

- A. REFERENCE THE LIGHTING CONTROL DIAGRAM FOR SYSTEM REQUIREMENTS.
- B. DIMMING PROTOCOL ABBREVIATIONS:
 NONE = SWITCH ONLY
 0-10 = 0-10 VDC
 MLV = MAGNETIC LOW VOLTAGE
 ELV = ELECTRONIC LOW VOLTAGE
 TRAC = LEADING-EDGE
 VERIFY = VERIFY WITH LED REPLACEMENT LAMP MANUFACTURER

GENERAL NOTES (TYPICAL ALL PANEL SCHEDULES)

- A. PROVIDE NEW AND/OR REUSE EXISTING CIRCUIT BREAKERS TO MATCH PANEL SCHEDULES SHOWN FOR EXISTING PANELS TO BE REUSED. MATCH PANEL TYPE, MANUFACTURER, AND U.L. RATINGS.

PANEL SCHEDULE NOTES (TYPICAL ALL PANEL SCHEDULES)

- CA = INDICATES CIRCUIT CONTROLLED BY CONTACTOR
- G = INDICATES 5 MA TRIP GFCI TYPE CIRCUIT BREAKER
- GE = INDICATES 30 MA TRIP GFCI TYPE CIRCUIT BREAKER
- L = INDICATES LOCK-ON CIRCUIT BREAKER
- ST = INDICATES SHUNT TRIP CIRCUIT BREAKER WITH 120 VOLT COIL
- X = INDICATES EXISTING CIRCUIT TO REMAIN
- N = INDICATES NEW CIRCUIT BREAKER TO BE INSTALLED MATCHING EXISTING PANEL LISTING
- XRW = INDICATES EXISTING CIRCUIT BREAKER SHALL BE USED FOR NEW CIRCUIT OR MADE SPARE FOLLOWING DEMOLITION
- XRL = INDICATES ADJUST EXISTING CIRCUIT BREAKER LOCATIONS AS REQUIRED FOR NEW 100A-3P CIRCUIT BREAKER

PANEL RP1

VOLTAGE: 120/208 Wye
 PH & WIRES: 3PH,4W
 BUSSING... 225

MAINS TYPE: 225A M.C.B.
 AIC RATING: EXISTING
 MOUNTING: SURFACE

LOCATION: ELEC 121
 FEEDER AMPACITY: 225
 REMARKS: EXISTING PANEL TO REMAIN
 MODIFY AS INDICATED

NOTES	LOAD DESCRIPTION	P	AMP	CCT	KVA LOADS			CCT	AMP	P	LOAD DESCRIPTION	NOTES		
					PH A	PH B	PH C							
	X EXISTING LOAD OR SPARE	2	20 A	1	0.50	1.08		2	20 A	1	ROOM 117 - RECEPT	X		
	X RECEPT - ROOM 122, 124	1	20 A	5			0.50	1.20	4	20 A	1	ROOM 123 - VENDING MACHINE	N,G	
	X RECEPT - ROOM 120	1	20 A	7	0.54	1.20			8	20 A	1	ROOM 123 - VENDING MACHINE	N,G	
	X RECEPT - ROOM 127	1	20 A	9			0.36	1.20	10	20 A	1	ROOM 123 - VENDING MACHINE	N,G	
	XRW RECEPT - ROOM 134	1	20 A	11				0.72	1.20	12	20 A	1	ROOM 123 - VENDING MACHINE	N,G
	XRW RECEPT - ROOM 131	1	20 A	13	0.72	1.20			14	20 A	1	ROOM 123 - VENDING MACHINE	N,G	
	X RECEPT - ROOM 132	1	20 A	15			0.72	0.50	16	20 A	1	ROOM 126 - REFRIGERATOR	N,G	
	XRW RECEPT - ROOM 116	1	20 A	17				0.72	0.50	18	20 A	1	ROOM 126 - FREEZER	N,G
	XRW RECEPT - ROOM 129 FURNITURE	1	20 A	19	0.90	0.50			20	20 A	1	ROOM 126 - DISHWASHER	N,G	
	XRW RECEPT - ROOM 129 FURNITURE	1	20 A	21			1.08	0.70	22	20 A	1	ROOM 126 - DISPOSAL	N,G	
	XRW RECEPT - ROOM 129	1	20 A	23				0.72	1.20	24	20 A	1	ROOM 126 - MICROWAVE	N,G
	XRW RECEPT - ROOM 128, 129	1	20 A	25	0.72	1.20			26	20 A	1	ROOM 126 - MICROWAVE	N,G	
	XRW (4) TV'S	1	20 A	27			1.00	0.72	28	20 A	1	ROOM 126 - RECEPT	N,G	
	X RECEPT - ROOM 133	1	20 A	29				0.90	0.90	30	20 A	1	ROOM 129 FURNITURE - RECEPT	XRW
	XRW RECEPT - ROOM 127	1	20 A	31	0.90	0.50			32	20 A	2	EXISTING LOAD OR SPARE	X	
	X RECEPT - ROOM 159	1	20 A	33			1.26	0.50	34	20 A	1			
	XRW RECEPT - ROOM 127	1	20 A	35				0.90	0.50	36	20 A	1	CABINET HEATER S-1	X
	XRW SPARE	1	20 A	37	0.00	8.76			38					
	X ELEVATOR CAB LIGHTS	1	20 A	39			0.50	9.30	40	100 A	3	PANEL 'RP1B'	N	
	X ELEVATOR PIT LIGHTS / RECEPT	1	20 A	41				1.00	8.74	42				
					CONNECTED AMPS: 160.48			CONNECTED KVA: 57.81						
					DEMAND LOAD AMPS: 101.55			DEMAND KVA: 36.59						
NOTES:														

PANEL ERP1

VOLTAGE: 120/208 Wye
 PH & WIRES: 3PH,4W
 BUSSING... 100

MAINS TYPE: 100A M.C.B.
 AIC RATING: EXISTING
 MOUNTING: SURFACE

LOCATION: ELEC 121
 FEEDER AMPACITY: 95
 REMARKS: EXISTING EM PANEL TO REMAIN
 MODIFY AS INDICATED

NOTES	LOAD DESCRIPTION	P	AMP	CCT	KVA LOADS			CCT	AMP	P	LOAD DESCRIPTION	NOTES		
					PH A	PH B	PH C							
	X FLOOR RECEPT - ROOM 100	1	20 A	1	0.18	0.50		2	20 A	1	METAL DETECTORS	XRW		
	X RECEPT - IT ROOM 104	1	20 A	3			0.36	0.72	4	20 A	1	IT ROOM 160 - RECEPT	X	
	XRW ROLLING GRILLE	1	20 A	5				0.36	0.72	6	20 A	1	ROOM 154 - RECEPT	X
	N.L. FACP	1	20 A	7	0.50	0.18			8	20 A	1	ROOM 153 - FLOOR RECEPT	X	
	XRW CCTV MONITORS - ROOM 176	1	20 A	9			0.75	0.50	10	20 A	1	SITE MOTORIZED MAN GATE	XRW	
	N.L. LCP1	1	20 A	11				0.10	0.50	12	20 A	1	SITE EM CALL PEDESTAL	XRW
	XRW ADA OPERATED DOORS	1	20 A	13	1.00	0.54			14	20 A	1	ROOM 157 - RECEPT	XRW	
	XRW SITE MOTORIZED ROLLING GATE	1	20 A	15			1.00	0.00	16	20 A	1	SPARE	XRW	
	XRW SITE MOTORIZED ROLLING GATE	1	20 A	17				1.00	0.00	18	20 A	1	SPARE	XRW
	X SENSOR CTRL WC 122	1	20 A	19	0.10	0.00			20	20 A	1	SPARE		
	X SENSOR CTRL WC 124	1	20 A	21			0.10	0.00	22	20 A	1	SPARE	XRW	
	X SENSOR CTRL WC 173	1	20 A	23				0.10	0.00	24	20 A	1	SPARE	XRW
	X SENSOR CTRL WC 174	1	20 A	25	0.10	0.00			26	20 A	1	SPARE	XRW	
	X GRAPHIC ANNUNCIATOR	1	20 A	27			0.10	0.10	28	20 A	1	ELEVATOR DETECTOR	X	
	X FLOOR RECEPT - ROOM 180	1	20 A	29				0.36	0.50	30	20 A	1	SMOKE DAMPERS	X
					CONNECTED AMPS: 28.78			CONNECTED KVA: 10.37						
					DEMAND LOAD AMPS: 28.78			DEMAND KVA: 10.37						
NOTES:														

PANEL RP1B

VOLTAGE: 120/208 Wye
 PH & WIRES: 3PH,4W
 BUSSING... 125

MAINS TYPE: LUGS ONLY
 AIC RATING: MATCH PANEL 'RP1'
 MOUNTING: SURFACE

LOCATION: ELEC 121
 FEEDER AMPACITY: 95
 REMARKS:

NOTES	LOAD DESCRIPTION	P	AMP	CCT	KVA LOADS			CCT	AMP	P	LOAD DESCRIPTION	NOTES		
					PH A	PH B	PH C							
	RECEPT - ROOM 162	1	20 A	1	1.08	0.72		2	20 A	1	ROOM 114 FURNITURE - RECEPT			
	RECEPT - ROOM 162	1	20 A	3			1.08	0.72	4	20 A	1	ROOM 113 FURNITURE - RECEPT		
	RECEPT - ROOM 162	1	20 A	5				1.08	1.08	6	20 A	1	ROOM 135, 136 - RECEPT	
	RECEPT - ROOM 162	1	20 A	7	0.72	0.68			8	20 A	1	ROOM 115 - RECEPT		
	RECEPT - ROOM 162	1	20 A	9			0.72	0.90	10	20 A	1	ROOM 137 - RECEPT		
	RECEPT - ROOM 162	1	20 A	11				0.72	0.72	12	20 A	1	ROOM 138 - RECEPT	
	RECEPT - ROOM 162	1	20 A	13	0.72	0.90			14	20 A	1	GENERAL PURPOSE - RECEPT		
	RECEPT - ROOM 163	1	20 A	15			1.08	0.68	16	20 A	1	ROOM 148 - RECEPT		
	RECEPT - ROOM 163	1	20 A	17				0.72	0.68	18	20 A	1	ROOM 148 - RECEPT	
	RECEPT - ROOM 163	1	20 A	19	0.72	0.90			20	20 A	1	ROOM 140 - RECEPT		
	RECEPT - ROOM 163	1	20 A	21			0.86	0.90	22	20 A	1	ROOM 141, 142 - RECEPT		
	RECEPT - ROOM 163	1	20 A	23				0.72	0.72	24	20 A	1	ROOM 113 FURNITURE - RECEPT	
	RECEPT - ROOM 163	1	20 A	25	0.72	0.16			26	20 A	1	MAIN STREET PENDANT - LIGHT		
	RECEPT - ROOM 153	1	20 A	27			0.72	0.20	28	15 A	1	CUH-03 & CUH-06		
	RECEPT - ROOM 153	1	20 A	29				0.72	0.36	30	20 A	1	ROOM 117 - FLOOR RECEPT	
	RECEPT - ROOM 153	1	20 A	31	0.72	0.00			32	20 A	1	SPARE		
	RECEPT - ROOM 153	1	20 A	33			0.72	0.00	34	20 A	1	SPARE		
	RECEPT - ROOM 153	1	20 A	35				0.72	0.00	36	20 A	1	SPARE	
	RECEPT - ROOM 153	1	20 A	37	0.72	--			38	--	1	SPACE		
	RECEPT - ROOM 153	1	20 A	39			0.72	--	40	--	1	SPACE		
	RECEPT - ROOM 153	1	20 A	41				0.50	--	42	--	1	SPACE	
					CONNECTED AMPS: 74.38			CONNECTED KVA: 26.80						
					DEMAND LOAD AMPS: 51.57			DEMAND KVA: 18.58						
NOTES: PROVIDE SOLID NEUTRAL BUS & GROUND BAR. PROVIDE LUG SIZES AS REQUIRED FOR FEEDER SIZE SHOWN ON PARTIAL ONE-LINE DIAGRAM														

McHenry & Associates Incorporated
MC&A
 Consulting Engineers est. 1960
 25001 Emery Road, Suite #200
 Warrensville Heights, Ohio 44128
 Phone: 216-292-4696
 Fax: 216-292-5874
 Email: mail@mchenryassociates.com

City of Kalamazoo - Crosstown Facility
 CPED & KDPS Workplace Renovation
 150 E Crosstown Parkway Kalamazoo MI 49001

Seal:

BID Set 08/21/2025
 © 2025, intersect studio, llc
 Project Number: 23-046

ELECTRICAL PANEL SCHEDULES

E605

8/07/2025 9:33:44 AM D:\02\ERP\1453\ERP_025_MerchRP1.rvt

GENERAL NOTES (TYPICAL ALL PANEL SCHEDULES)

- A. PROVIDE NEW AND/OR REUSE EXISTING CIRCUIT BREAKERS TO MATCH PANEL SCHEDULES SHOWN FOR EXISTING PANELS TO BE REUSED. MATCH PANEL TYPE, MANUFACTURER, AND U.L. RATINGS.

PANEL SCHEDULE NOTES (TYPICAL ALL PANEL SCHEDULES)

- CA # INDICATES CIRCUIT CONTROLLED BY CONTACTOR
- G # INDICATES 5 MA TRIP GFCI TYPE CIRCUIT BREAKER
- GE # INDICATES 30 MA TRIP GFCI TYPE CIRCUIT BREAKER
- L # INDICATES LOCK-ON CIRCUIT BREAKER
- ST # INDICATES SHUNT TRIP CIRCUIT BREAKER WITH 120 VOLT COIL
- X # INDICATES EXISTING CIRCUIT TO REMAIN
- N # INDICATES NEW CIRCUIT BREAKER TO BE INSTALLED MATCHING EXISTING PANEL LISTING
- XRW # INDICATES EXISTING CIRCUIT BREAKER SHALL BE USED FOR NEW CIRCUIT OR MADE SPARE FOLLOWING DEMOLITION
- XRL # INDICATES ADJUST EXISTING CIRCUIT BREAKER LOCATIONS AS REQUIRED FOR NEW 100A-3P CIRCUIT BREAKER

PANEL ERP2		VOLTAGE: 120/208 Wye		PH & WIRES: 3PH,4W		BUSSING... 225		MAINS TYPE: LUGS ONLY		AIC RATING: EXISTING		MOUNTING: SURFACE		LOCATION: ELEC 243		FEEDER AMPACITY: 95		REMARKS: EXISTING EM PANEL TO REMAIN MODIFY AS INDICATED	
NOTES	LOAD DESCRIPTION	P	AMP	CCT	KVA LOADS			CCT	AMP	P	LOAD DESCRIPTION	NOTES							
					PH A	PH B	PH C												
	XRW SPARE	1	20 A	1	0.00	0.54		2	20 A	1	ROOM 275 - RECEIPT	X							
	XRW CCTV MONITORS - ROOM 216	1	20 A	3		0.75	0.36		4	20 A	1	ROOM 275 - RECEIPT	X						
	XRW SPARE	1	20 A	5					6	20 A	1	ROOM 198 - RECEIPT	X						
	XRW SPARE	1	20 A	7	0.00	0.36			8	20 A	1	ROOM 197 - RECEIPT	X						
	X RECEIPT - ROOM 257	1	20 A	9		0.90	0.50		10	20 A	1	HAVEL BROS CTRL BOX 243	X						
	X RECEIPT - ROOM 258	1	20 A	11			0.18	0.72	12	20 A	1	ROOM 234 - RECEIPT	X						
	X RECEIPT - ROOM 258	1	20 A	13	0.18	0.54			14	20 A	1	ROOM 241 - RECEIPT	X						
	X RECEIPT - ROOM 259	1	20 A	15		0.18	0.36		16	20 A	1	ROOM 241 - RECEIPT	X						
	X RECEIPT - ROOM 260	1	20 A	17			0.90	0.90	18	20 A	1	ROOM 225 - RECEIPT	X						
	X REFRIGERATOR - ROOM 227	1	20 A	19	1.00	0.90			20	20 A	1	ROOM 223 - RECEIPT	X						
	X MICROWAVE - ROOM 227	1	20 A	21		1.00	0.36		22	20 A	1	ROOM 240 - RECEIPT	X						
	X STAIRWELL S-4	1	20 A	23			0.10	0.18	24	20 A	1	ROOM 227 - RECEIPT	X						
	X SENSOR CTRL WC 251	1	20 A	25	0.10	0.50			26	20 A	1	FIRE BELLS	X						
	X SENSOR CTRL WC 253	1	20 A	27		0.10	0.50		28	20 A	1	SMOKE DAMPERS	X						
	X ROOM 276/279 IRIS READER	1	20 A	29			0.10	0.10	30	20 A	1	ELEVATOR 3 SMOKE	X						
	X SERVICE ELEVATOR SUMP PUMP	1	20 A	31	0.50	0.36			32	20 A	1	ROOM 279 - RECEIPT	X						
	X SERVICE ELEVATOR PIT/CAB LIGHT	1	20 A	33		0.50	0.36		34	20 A	1	ROOM 279 - RECEIPT	X						
	X O/H DOOR - ROOM 273	1	20 A	35			0.50	0.36	36	20 A	1	ROOM 271, 279 - RECEIPT	X						
	X STAIRWELL S-4	1	20 A	37	0.10	0.10			38	20 A	1	CAMERA (SE CORNER)	X						
	X SERVICE ELEVATOR LIGHT / RECEIPT	1	20 A	39		0.50	0.50		40	20 A	1	ROOM 235 - FIRE PANEL	X						
	X PRE-ACTION AIR COMPR - ROOM 235	1	20 A	41			0.50	0.50	42	20 A	1	ROOM 243 - FIRE PANEL	X						
		CONNECTED AMPS:		48.44	5.18		6.87		5.40		CONNECTED KVA:		17.45						
		DEMAND LOAD AMPS:		48.44							DEMAND KVA:		17.45						
NOTES:																			

PANEL RP2B		VOLTAGE: 120/208 Wye		PH & WIRES: 3PH,4W		BUSSING... 100		MAINS TYPE: 100A M.C.B		AIC RATING: EXISTING		MOUNTING: SURFACE		LOCATION: ELEC 143-B		FEEDER AMPACITY: 95		REMARKS: EXISTING PANEL TO REMAIN MODIFY AS INDICATED	
NOTES	LOAD DESCRIPTION	P	AMP	CCT	KVA LOADS			CCT	AMP	P	LOAD DESCRIPTION	NOTES							
					PH A	PH B	PH C												
	X RECEIPT - ROOM 176	1	20 A	1	0.36	0.72		2	20 A	1	ROOM 145 - RECEIPT	XRW							
	X RECEIPT - ROOM 176	1	20 A	3		0.36	0.40		4	15 A	1	CUH-01 & CUH-02	N						
	XRW RECEIPT - ROOM 154, 166, 168	1	20 A	5				1.08	0.00	6	20 A	1	SPARE	XRW					
	XRW RECEIPT - ROOM 163, 167	1	20 A	7	1.08	0.00			8	20 A	1	SPARE	XRW						
	XRW RECEIPT - ROOM 167, 183	1	20 A	9		1.08	0.00		10	20 A	1	SPARE	XRW						
	XRW RECEIPT - ROOM 176	1	20 A	11				0.90	0.90	12	20 A	1	ROOM 147 - RECEIPT	XRW					
	XRW RECEIPT - ROOM 176	1	20 A	13	0.90	0.90			14	20 A	1	ROOM 169 - RECEIPT	N						
	XRW RECEIPT - ROOM 176	1	20 A	15		1.08	--		16	--	1	SPACE							
	XRW RECEIPT - ROOM 176	1	20 A	17				1.08	--	18	--	1	SPACE						
	X ELEVATOR PIT LIGHT/RECEIPT	1	20 A	19	0.50	0.00			20	20 A	1	SPARE	XRW						
	XRW RECEIPT - ROOM 176	1	20 A	21		1.08	--		22	--	1	SPACE							
	N RECEIPT - ROOM 176	1	20 A	23				0.50	--	24	--	1	SPACE						
		CONNECTED AMPS:		35.86	4.46		4.00		4.46		CONNECTED KVA:		12.92						
		DEMAND LOAD AMPS:		33.06							DEMAND KVA:		11.91						
NOTES:																			

PANEL LP1		VOLTAGE: 480/277 Wye		PH & WIRES: 3PH,4W		BUSSING... 125		MAINS TYPE: LUGS ONLY		AIC RATING: EXISTING		MOUNTING: SURFACE		LOCATION: ELEC 143-B		FEEDER AMPACITY: 95		REMARKS: EXISTING PANEL TO REMAIN MODIFY AS INDICATED	
NOTES	LOAD DESCRIPTION	P	AMP	CCT	KVA LOADS			CCT	AMP	P	LOAD DESCRIPTION	NOTES							
					PH A	PH B	PH C												
	XRW LIGHTING - CPED SE	1	20 A	1	2.69	0.00		2	20 A	1	SPARE	XRW							
	XRW LIGHTING - CPED SW	1	20 A	3		2.24	0.00		4	20 A	1	SPARE	XRW						
	XRW LIGHTING - CPED NW	1	20 A	5				1.71	0.00	6	20 A	1	SPARE						
	XRW LIGHTING - CPED NE	1	20 A	7	2.60	0.00			8	20 A	1	SPARE							
	XRW SPARE	1	20 A	9		0.00	0.00		10	20 A	1	SPARE							
	XRW SPARE	1	20 A	11			0.00	0.00	12	20 A	1	SPARE							
	XRW SPARE	1	20 A	13	0.00	0.00			14	20 A	1	SPARE							
	XRW SPARE	1	20 A	15		0.00	0.00		16	20 A	1	SPARE							
	XRW SPARE	1	20 A	17				0.00	0.00	18	20 A	2	SPARE						
	XRW SPARE	1	20 A	19	0.00	0.00			20	20 A	1	SPARE							
	XRW SPARE	1	20 A	21		0.00	0.00		22	20 A	1	SPARE							
	XRW SPARE	1	20 A	23			0.00	0.00	24	20 A	2	SPARE							
	SPARE	1	20 A	25	0.00	--			26	--	1	SPACE							
	SPACE	1	--	27		--	--		28	--	1	SPACE							
	SPACE	1	--	29			--	--	30	--	1	SPACE							
		CONNECTED AMPS:		11.11	5.29		2.24		1.71		CONNECTED KVA:		9.24						
		DEMAND LOAD AMPS:		11.11							DEMAND KVA:		9.24						
NOTES:																			

PANEL RP2		VOLTAGE: 120/208 Wye		PH & WIRES: 3PH,4W		BUSSING... 225		MAINS TYPE: 225A M.C.B		AIC RATING: EXISTING		MOUNTING: SURFACE		LOCATION: ELEC 143-B		FEEDER AMPACITY: 225		REMARKS: EXISTING PANEL TO REMAIN MODIFY AS INDICATED	
NOTES	LOAD DESCRIPTION	P	AMP	CCT	KVA LOADS			CCT	AMP	P	LOAD DESCRIPTION	NOTES							
					PH A	PH B	PH C												
	X RECEIPT - ROOM 100	1	20 A	1	0.90	1.08		2	20 A	1	ROOM 182 - FLOOR RECEIPT	XRW							
	X RECEIPT - ROOM 112	1	20 A	3		1.44	0.72		4	20 A	1	ROOM 105, 106 - RECEIPT	X						
	X RECEIPT - ROOM 102, 113	1	20 A	5				1.08	0.90	6	20 A	1	ROOM 182 - RECEIPT	XRW					
	X RECEIPT - ROOM 103, 106	1	20 A	7	0.90	0.90			8	20 A	1	ROOM 182 - RECEIPT	XRW						
	XRW (4) TV'S	1	20 A	9		1.00	0.90		10	20 A	1	ROOM 151 - RECEIPT	XRW						
	XRW (4) TV'S	1	20 A	11				1.00	0.75	12	20 A	1	LIT SIGNAGE	XRW					
	X FLOOR RECEIPT - ROOM 103	1	20 A	13	0.72	0.50			14	20 A	1	MONUMENT SIGN	XRW						
	XRW RECEIPT - GENERAL PURPOSE	1	20 A	15		0.72	0.90		16	20 A	1	ROOM 172, 180 - RECEIPT	XRW						
	XRW RECEIPT - ROOM 101, 108	1	20 A	17				1.08	0.54	18	20 A	1	ROOM 180 - RECEIPT	XRW					
	X RECEIPT - ROOM 113	1	20 A	19	0.36	0.00			20	20 A	1	SPARE	XRW						
	XRW RECEIPT - ROOM 107, 110	1	20 A	21		1.26	0.72		22	20 A	1	ROOM 146 - RECEIPT	XRW						
	X RECEIPT - ROOM 181	1	20 A	23				0.18	0.72	24	20 A	1	ROOM 146 - RECEIPT	XRW					
	XRW (4) TV'S	1	20 A	25	1.00	0.72			26	20 A	1	ROOM 145 - RECEIPT	XRW						
	XRW FLOOR RECEIPT - ROOM 106	1	20 A	27		0.72	0.54		28	20 A	1	EWC & ROOM 173,174 - RECEIPT	X						
	XRW FLOOR RECEIPT - ROOM 106	1	20 A	29				0.72	0.50	30	20 A	2	EXISTING LOAD OR SPARE	X					
	XRW RECEIPT - ROOM 106	1	20 A	31	0.72	0.50			32	20 A	1	EXISTING LOAD OR SPARE	X						
	XRW RECEIPT - ROOM 106	1	20 A	33		0.72	0.50		34	20 A	2	EXISTING LOAD OR SPARE	X						
	XRW RECEIPT - ROOM 149	1	20 A	35				0.72	0.50	36	20 A	1	EXISTING LOAD OR SPARE	X					
	XRW RECEIPT - ROOM 150	1	20 A	37	0.72	4.46			38	20 A	1	EXISTING LOAD OR SPARE	X						
	XRW RECEIPT - ROOM 103	1	20 A	39		1.08	4.00		40	100 A	3	PANEL 'RP2B'	X						
	XRW RECEIPT - ROOM 103	1	20 A	41				0.90	4.46	42	20 A	1	EXISTING LOAD OR SPARE	X					
		CONNECTED AMPS:		118.66	13.48		15.22		14.05		CONNECTED KVA:		42.75						
		DEMAND LOAD AMPS:		78.97							DEMAND KVA:		28.45						
NOTES:																			

McHenry & Associates Incorporated
Mc&A
 Consulting Engineers est. 1960
 25001 Emery Road, Suite #200
 Warrensville Heights, Ohio 44128
 Phone: 216-292-4696
 Fax: 216-292-5874
 Email: mail@mchenryassociates.com

City of Kalamazoo - Crosstown Facility
 CPED & KDPS Workplace Renovation
 150 E Crosstown Parkway Kalamazoo MI 49001

Seal:

BID Set 08/21/2025
 © 2025, intersect studio, llc
 Project Number: 23-046

ELECTRICAL PANEL SCHEDULES

E606

GENERAL NOTES (TYPICAL ALL PANEL SCHEDULES)

- A. PROVIDE NEW AND/OR REUSE EXISTING CIRCUIT BREAKERS TO MATCH PANEL SCHEDULES SHOWN FOR EXISTING PANELS TO BE REUSED. MATCH PANEL TYPE, MANUFACTURER, AND U.L. RATINGS.

PANEL SCHEDULE NOTES (TYPICAL ALL PANEL SCHEDULES)

- CA # INDICATES CIRCUIT CONTROLLED BY CONTACTOR
- G # INDICATES 5 MA TRIP GFCI TYPE CIRCUIT BREAKER
- GE # INDICATES 30 MA TRIP GFCI TYPE CIRCUIT BREAKER
- L # INDICATES LOCK-ON CIRCUIT BREAKER
- ST # INDICATES SHUNT TRIP CIRCUIT BREAKER WITH 120 VOLT COIL
- X # INDICATES EXISTING CIRCUIT TO REMAIN
- N # INDICATES NEW CIRCUIT BREAKER TO BE INSTALLED MATCHING EXISTING PANEL LISTING
- XRW # INDICATES EXISTING CIRCUIT BREAKER SHALL BE USED FOR NEW CIRCUIT OR MADE SPARE FOLLOWING DEMOLITION
- XRL # INDICATES ADJUST EXISTING CIRCUIT BREAKER LOCATIONS AS REQUIRED FOR NEW 100A-3P CIRCUIT BREAKER

PANEL LP2		VOLTAGE: 480/277 Wye		PH & WIRES: 3PH,4W		BUSSING... 125		MAINS TYPE: LUGS ONLY		AIC RATING: EXISTING		MOUNTING: SURFACE		LOCATION: ELEC 243		FEEDER AMPACITY: 125		REMARKS: EXISTING PANEL TO REMAIN MODIFY AS INDICATED	
NOTES	LOAD DESCRIPTION	P	AMP	CCT	KVA LOADS			CCT	AMP	P	LOAD DESCRIPTION	NOTES							
					PH A	PH B	PH C												
X	LIGHTS RM 179, 181, 182	1	--	1	--	--		2	--	1	SITE LIGHTING	X							
X	RM 177,183,184,185,187,191,206,207,...	1	--	3				4	--	1	SITE LIGHTING	X							
	SPARE	1	20 A	5				6	--	1	SITE LIGHTING	X							
X	LTS RM 188, 193, 194, 202-205	1	--	7				8	--	1	SITE LIGHTING	X							
X	LIGHTS RM 201 CONFERENCE ROOM	1	--	9				10	--	1	SITE LIGHTING	X							
X	LTS RM 190, 221, 228, 238, 261, 266,...	1	--	11				12	--	1	SITE LIGHTING	X							
XRW	LIGHTS - KDPS	1	20 A	13	3.54	--		14	--	1	LT RM 229, 230, 233-237	X							
XRW	SPARE	1	20 A	15				16	--	1	LT RM 248, 262, 263, 264	X							
X	LT RM 198, 199, 244, 245	1	--	17				18	--	1	LIGHTS LOADING DOCK	X							
X	LT RM 273, 274, 275, 278	1	--	19				20	--	1	SITE LIGHTING	X							
X	LT R, 276, 277, 284, 285	1	--	21				22	--	1	SITE LIGHTING	X							
X	SITE LIGHTING	1	--	23				24	20 A	1	SITE LIGHTING	N							
	SPARE	1	20 A	25	0.00	--		26	--	1	SPACE								
	SPACE	1	--	27				28	--	1	SPACE								
	SPACE	1	--	29				30	--	1	SPACE								
		CONNECTED AMPS:		4.81	3.54		0.00		0.46		CONNECTED KVA: 4.00								
		DEMAND LOAD AMPS:		4.81							DEMAND KVA: 4.00								
NOTES:																			

PANEL ERP5		VOLTAGE: 120/208 Wye		PH & WIRES: 3PH,4W		BUSSING... 150		MAINS TYPE: 150A M.C.B.		AIC RATING: EXISTING		MOUNTING: SURFACE		LOCATION: ELEC 243		FEEDER AMPACITY: 150		REMARKS: EXISTING EM PANEL TO REMAIN MODIFY AS INDICATED	
NOTES	LOAD DESCRIPTION	P	AMP	CCT	KVA LOADS			CCT	AMP	P	LOAD DESCRIPTION	NOTES							
					PH A	PH B	PH C												
X	RECEPT - ROOM 244	1	20 A	1	0.36	0.36		2	20 A	1	ROOM 224 - RECEPT	X							
X	RECEPT - ROOM 245	1	20 A	3		0.36	0.36		4	20 A	1	ROOM 224 - RECEPT	X						
X	RECEPT - ROOM 245	1	20 A	5					6	20 A	1	ROOM 224 - RECEPT	X						
X	RECEPT - ROOM 209	1	20 A	7	0.36	0.36			8	20 A	1	ROOM 224 - RECEPT	X						
X	RECEPT - ROOM 209	1	20 A	9		0.36	0.36		10	20 A	1	ROOM 224 - RECEPT	X						
X	RECEPT - ROOM 209	1	20 A	11					12	20 A	1	ROOM 224 - RECEPT	X						
X	IT ROOM UPS	2	100 A	13	5.00	0.36			14	20 A	1	ROOM 224 - RECEPT	X						
				15		5.00	0.36		16	20 A	1	ROOM 224 - RECEPT	X						
X	RECEPT - ROOM 246	1	20 A	17					18	20 A	1	ROOM 224 - RECEPT	X						
X	RECEPT - ROOM 246	1	20 A	19	0.36	0.36			20	20 A	1	ROOM 224 - RECEPT	X						
X	RECEPT - ROOM 246	1	20 A	21		0.36	0.36		22	20 A	1	ROOM 224 - RECEPT	X						
X	RECEPT - ROOM 246	1	20 A	23					24	20 A	1	ROOM 224 - RECEPT	X						
X	RECEPT - ROOM 246	1	20 A	25	0.36	1.00			26	20 A	1	ROOM 222 - RECEPT	X						
X	RECEPT - ROOM 247	1	20 A	27		0.36	1.00		28	20 A	1	ROOM 222 - RECEPT	X						
X	RECEPT - ROOM 247	1	20 A	29					30	20 A	1	ROOM 222 - RECEPT	X						
X	RECEPT - ROOM 247	1	20 A	31	0.36	1.00			32	20 A	1	ROOM 222 - RECEPT	X						
X	RECEPT - ROOM 247	1	20 A	33		0.36	1.00		34	20 A	2	EXTERIOR LIGHTS	X						
X	RECEPT - ROOM 209	1	20 A	35					36	20 A	1	ROOM 222 - RECEPT	X						
				37	5.00	1.00			38	20 A	1	ROOM 222 - RECEPT	X						
X	PANEL 'ERP5B'	3	60 A	39		5.00	1.00		40	20 A	1	ROOM 222 - RECEPT	X						
				41					42	20 A	1	ROOM 222 - RECEPT	X						
		CONNECTED AMPS:		122.35	16.24		16.24		11.60		CONNECTED KVA: 44.08								
		DEMAND LOAD AMPS:		122.35							DEMAND KVA: 44.08								
NOTES:																			

PANEL RP4		VOLTAGE: 120/208 Wye		PH & WIRES: 3PH,4W		BUSSING... 150		MAINS TYPE: 150A M.C.B.		AIC RATING: EXISTING		MOUNTING: SURFACE		LOCATION: ELEC 243		FEEDER AMPACITY: 150		REMARKS: EXISTING PANEL TO REMAIN MODIFY AS INDICATED	
NOTES	LOAD DESCRIPTION	P	AMP	CCT	KVA LOADS			CCT	AMP	P	LOAD DESCRIPTION	NOTES							
					PH A	PH B	PH C												
X	EXISTING LOAD OR SPARE	2	20 A	1	0.50	0.00		2	20 A	1	SPARE	XRW							
				3				4	20 A	1	ROOM 248 - RECEPT	X							
				5				6	20 A	1	ROOM 263 - RECEPT	X							
X	EXISTING LOAD OR SPARE	2	20 A	7	0.50	0.90		8	20 A	1	ROOM 273 - RECEPT	X							
X	TCP	1	20 A	9		0.50	0.00		10	20 A	1	SPARE							
X	RECEPT - ROOM 218, 251, 253	1	20 A	11				12	20 A	1	ROOM 278, 282 - RECEPT	X							
XRW	SPARE	1	20 A	13	0.00	0.18		14	20 A	1	ROOM 268 - RECEPT	X							
X	RECEPT - ROOM 216, 255	1	20 A	15		0.72	0.54		16	20 A	1	ROOM 196 - RECEPT	X						
XRW	SPARE	1	20 A	17				18	20 A	1	ROOM 199 - RECEPT	X							
X	RECEPT - ROOM 215, 216	1	20 A	19	0.54	0.72		20	20 A	1	ROOM 229 - RECEPT	X							
X	RECEPT - ROOM 214, 256	1	20 A	21		1.08	0.54		22	20 A	1	ROOM 233 - RECEPT	X						
X	RECEPT - ROOM 261	1	20 A	23			0.54	0.54	24	20 A	1	ROOM 233 - RECEPT	X						
X	RECEPT - ROOM 261	1	20 A	25	1.08	0.18		26	20 A	1	ROOM 260 - RECEPT	X							
X	RECEPT - ROOM 262	1	20 A	27		0.54	0.10		28	20 A	1	TIMECLOCK	X						
X	RECEPT - ROOM 263	1	20 A	29			0.18	0.50	30	20 A	1	UH-103, UH-104, UH-105	X						
X	RECEPT - ROOM 263	1	20 A	31	0.18	0.50		32	20 A	1	CH-104	X							
X	RECEPT - ROOM 264	1	20 A	33		0.18	1.00		34	20 A	2	SPRINKLER PUMP	X						
X	RECEPT - ROOM 263	1	20 A	35			0.18	1.00	36	20 A	1								
X	MONUMENT PARK SIGN	1	20 A	37	0.50	0.50		38	20 A	1	CH-105, UH-106, UH-107	X							
X	CAR LIFT	2	20 A	39		1.00	0.50		40	20 A	1	UH-108, UH-109, CH-106	X						
				41				42	20 A	1	EF-102	X							
		CONNECTED AMPS:		61.12	6.28		8.10		7.64		CONNECTED KVA: 22.02								
		DEMAND LOAD AMPS:		61.12							DEMAND KVA: 22.02								
NOTES:																			

PANEL RP3		VOLTAGE: 120/208 Wye		PH & WIRES: 3PH,4W		BUSSING... 225		MAINS TYPE: 225A M.C.B.		AIC RATING: EXISTING		MOUNTING: SURFACE		LOCATION: ELEC 243		FEEDER AMPACITY: 225		REMARKS: EXISTING PANEL TO REMAIN MODIFY AS INDICATED	
NOTES	LOAD DESCRIPTION	P	AMP	CCT	KVA LOADS			CCT	AMP	P	LOAD DESCRIPTION	NOTES							
					PH A	PH B	PH C												
X	RECEPT - ROOM 177, 178	1	20 A	1	0.90	1.00		2	20 A	1	(4) TVS	XRW							
X	RECEPT - ROOM 192	1	20 A	3		0.90	0.90		4	20 A	1	ROOM 188 - RECEPT	X						
X	RECEPT - ROOM 195	1	20 A	5					6	20 A	1	ROOM 193 - RECEPT	X						
XRL	RECEPT - ROOM 185	1	20 A	7	0.90	1.08			8	20 A	1	ROOM 188, 189, 190 - RECEPT	XRW						
X	RECEPT - ROOM 191	1	20 A	9		0.54	0.90		10	20 A	1	ROOM 202 - RECEPT	X						
X	RECEPT - ROOM 191, 196, 221	1	20 A	11					12	20 A	1	ROOM 201, 202 - RECEPT	X						
XRW	RECEPT - ROOM 184	1	20 A	13	0.72	0.90			14	20 A	1	ROOM 204 - RECEPT	X						
X	RECEPT - ROOM 184	1	20 A	15		0.72	0.36		16	20 A	1	ROOM 203 - RECEPT	X						
				17					18	20 A	1	ROOM 203 - RECEPT	X						
N	PANEL 'RP3B'	3	100 A	19	8.93	1.00			20	20 A	1	ROOM 203 - RECEPT	X						
X	RECEPT - ROOM 187	1	20 A	21					22	20 A	1	ROOM 203 - DISHWASHER	X						
X	RECEPT - ROOM 205	1	20 A	23					24	20 A	1	ROOM 203 - RECEPT	X						
X	RECEPT - ROOM 205	1	20 A	25	0.54	0.90			26	20 A	1	ROOM 219A - RECEPT							
X	RECEPT - ROOM 205	1	20 A	27		0.72	1.08		28	20 A	1	ROOM 186, 187 - RECEPT	XRW						
X	RECEPT - ROOM 196	1	20 A	29					30	20 A	1	ROOM 201 - RECEPT	X						
X	RECEPT - ROOM 207	1	20 A	31	0.90	0.54			32	20 A	1	ROOM 201 - RECEPT	X						
X	RECEPT - ROOM 208	1	20 A	33		0.90	0.54		34	20 A	1	ROOM 201 - RECEPT	X						
X	RECEPT - ROOM 219B	1	20 A	35					36	20 A	1	ROOM 192 - RECEPT	X						
X	CH-103, EXUH-001, EXUH-002	1	20 A	37	0.50	0.00			38	20 A	1	SPARE	XRW						
X	EF-101, CH-102, UH-102	1	20 A	39		0.50	0.50		40	20 A	1	ELEVATOR CAB LIGHTS	X						
X	UH-101, ERV-101	1	20 A	41					42	20 A	1	ELEVATOR PIT LIGHTS / RECEPT	X						
		CONNECTED AMPS:		156.05	18.81		18.25		19.16		CONNECTED KVA: 56.22								
		DEMAND LOAD AMPS:		126.95							DEMAND KVA: 45.74								
NOTES:																			

McHenry & Associates Incorporated
MC&A
 Consulting Engineers est. 1960
 25001 Emery Road, Suite #200
 Warrensville Heights, Ohio 44128
 Phone: 216-292-4696
 Fax: 216-292-5874
 Email: mail@mchenryassociates.com

City of Kalamazoo - Crosstown Facility
 CPED & KDPS Workplace Renovation
 150 E Crosstown Parkway Kalamazoo MI 49001

Seal:

GENERAL NOTES (TYPICAL ALL PANEL SCHEDULES)

- A. PROVIDE NEW AND/OR REUSE EXISTING CIRCUIT BREAKERS TO MATCH PANEL SCHEDULES SHOWN FOR EXISTING PANELS TO BE REUSED. MATCH PANEL TYPE, MANUFACTURER, AND U.L. RATINGS.

PANEL SCHEDULE NOTES (TYPICAL ALL PANEL SCHEDULES)

- CA # INDICATES CIRCUIT CONTROLLED BY CONTACTOR
- G # INDICATES 5 MA TRIP GFCI TYPE CIRCUIT BREAKER
- GE # INDICATES 30 MA TRIP GFCI TYPE CIRCUIT BREAKER
- L # INDICATES LOCK-ON CIRCUIT BREAKER
- ST # INDICATES SHUNT TRIP CIRCUIT BREAKER WITH 120 VOLT COIL
- X # INDICATES EXISTING CIRCUIT TO REMAIN
- N # INDICATES NEW CIRCUIT BREAKER TO BE INSTALLED MATCHING EXISTING PANEL LISTING
- XRW # INDICATES EXISTING CIRCUIT BREAKER SHALL BE USED FOR NEW CIRCUIT OR MADE SPARE FOLLOWING DEMOLITION
- XRL # INDICATES ADJUST EXISTING CIRCUIT BREAKER LOCATIONS AS REQUIRED FOR NEW 100A-3P CIRCUIT BREAKER

PANEL		EMDP		KVA LOADS				KVA LOADS				LOAD DESCRIPTION		NOTES
NOTES	LOAD DESCRIPTION	P	AMP	CCT	A	B	C	CCT	AMP	P				
	X EF-201	3	15 A	1	0.00	0.00		4	15 A	3			EF-202	X
				5			0.00	6						
				7	0.00	0.00		8						
	SPARE	3	15 A	9			0.00	10	15 A	3			TRAFFIC CTRL GATE	X
				11				12						
				13	0.00	0.00		14						
	X FC-104	3	20 A	15			0.00	16	20 A	3			FC-103	X
				17				18						
				19	4.59	0.00		20						
	X PANEL 'ELDP'	3	60 A	21			7.65	22	20 A	3			SPARE	
				23				24						
				25	--	0.00		26						
	SPACE	1	--	27		--	0.00	28	100 A	3			EM BOILER PANEL	X
	SPACE	1	--	29			--	30						
				31	--	13.14		32						
				33			--	34	225 A	3			PANEL 'ERDP' VIA TE1	X
				35			--	36						
				CONNECTED AMPS:		63.25	17.73	19.37	15.50	CONNECTED KVA:		52.59		
				DEMAND LOAD AMPS:		63.25				DEMAND KVA:		52.59		
	NOTES:													

PANEL		RP5		KVA LOADS				KVA LOADS				LOAD DESCRIPTION		NOTES	
NOTES	LOAD DESCRIPTION	P	AMP	CCT	PH A	PH B	PH C	CCT	AMP	P					
	X RECEPT - ROOM 301	1	20 A	1	0.72	0.18		2	20 A	1			ROOM 311 - MICROWAVE	X	
	X RECEPT - ROOM 302	1	20 A	3		0.54	1.08	4	20 A	1			ROOM 301 - RECEPT	XRW	
	X RECEPT - ROOM 302 COUNTER	1	20 A	5			0.18	1.22	6	20 A	1		ROOM 301 - RECEPT	XRW	
	X MICROWAVE - ROOM 302	1	20 A	7	0.18	0.36		8	20 A	1			ROOM 311 - RECEPT	X	
	XRW RECEPT - ROOM 301	1	20 A	9			1.08	0.18	10	20 A	1		ROOM 311 - RECEPT	X	
	X RECEPT - ROOM 316	1	20 A	11				0.90	0.54	12	20 A	1		ROOM 313 - RECEPT	X
	X RECEPT - ROOM 315	1	20 A	13	0.72	1.08		14	20 A	1			ROOM 313, 347 - RECEPT	X	
	X RECEPT - ROOM 311 COUNTER	1	20 A	15			0.90	0.50	16	20 A	1		ROOM 301 - FUTURE RECEPT	XRW	
	X RECEPT - ROOM 319	1	20 A	17				1.08	0.54	18	20 A	1		ROOM 314, 346, 347 - RECEPT	X
	X RECEPT - ROOM 317	1	20 A	19	0.90	0.83		20	20 A	1			ROOM 347 - RECEPT	X	
	X RECEPT - ROOM 302	1	20 A	21			0.54	0.50	22	20 A	1		ROOM 302 - FUTURE RECEPT	XRW	
	XRW RECEPT - ROOM 301	1	20 A	23				1.08	1.00	24	20 A	1		(4) TV'S	XRW
	X RECEPT - ROOM 301, 304, 306	1	20 A	25	0.90	0.86		26	20 A	1			ROOM 347 - RECEPT & FANS	XRW	
	X RECEPT - ROOM 305, 308	1	20 A	27			0.18	1.20	28	20 A	1		ROOM 311 - SAUNA	N,G	
	X RECEPT - ROOM 302	1	20 A	29				0.72	1.20	30	20 A	1		ROOM 311 - SAUNA	N,G
				31	0.00	1.20		32	20 A	1			ROOM 311 - SAUNA	N,G	
	X PENTHOUSE PANEL	3	40 A	33			0.00	0.18	34	20 A	1		ROOM 347 - RECEPT	X	
				35				0.00	0.72	36	20 A	1		ROOM 347 - RECEPT	X
	X ELEVATOR CAB LIGHTS	1	25 A	37	1.00	0.00		38	20 A	1			SPARE	XRW	
	X RECEPT - ELEV EQ	1	20 A	39			0.18	0.90	40	20 A	1		ROOM 317 - RECEPT	X	
	XRW RECEPT - ROOM 301	1	20 A	41				1.08	0.50	42	20 A	1		TCP	X
				CONNECTED AMPS:		76.75	8.93	7.96	10.76	CONNECTED KVA:		27.65			
				DEMAND LOAD AMPS:		58.11				DEMAND KVA:		20.94			
	NOTES:														

PANEL		ERP3		KVA LOADS				KVA LOADS				LOAD DESCRIPTION		NOTES	
NOTES	LOAD DESCRIPTION	P	AMP	CCT	A	B	C	CCT	AMP	P					
	X CU-103	3	20 A	1	0.00	0.00		4	20 A	3			CU-104	X	
				5			0.00	6							
				7	3.10	4.86		8							
	X PANEL 'ERP1'	3	100 A	9			3.63	1.22	10	100 A	3		PANEL 'ERP3'	X	
				11				3.64	4.22	12					
				13	5.18	0.00		14							
	X PANEL 'ERP2'	3	100 A	15			6.87	0.00	16	20 A	3		FIRE SHUTTERS	X	
				17				5.40	0.00	18					
				19	0.00	0.00		20							
	X CU-106	2	20 A	21			0.00	0.00	22	20 A	2		CU-101	X	
				23				0.00	0.00	24					
	X CU-102	2	20 A	25	0.00	0.00		26	20 A	2			CU-105	X	
				27			0.00	0.00	28						
	X FC-101	2	50 A	29				0.00	0.00	30	50 A	2		FC-106	X
				31	0.00	0.00		32							
	X FC-105	2	40 A	33			0.00	0.00	34	40 A	2		FC-102	X	
				35				0.00	0.00	36	20 A	1		EXISTING LOAD	X
	X EXISTING LOAD OR SPARE	1	--	37	--	0.00		38	20 A	1			EXISTING LOAD	X	
	SPACE	1	--	39		--	--	40	--	1			SPACE		
	SPACE	1	--	41			--	--	42	--	1		SPACE		
				43	0.00	--		44	--	1					
	X PANEL 'ERP4'	3	200 A	45			0.00	--	46	--	1				
				47				0.00	--	48	--	1			
				CONNECTED AMPS:		105.81	13.14	11.72	13.26	CONNECTED KVA:		38.12			
				DEMAND LOAD AMPS:		105.81				DEMAND KVA:		38.12			
	NOTES:														

PANEL		ERP3		KVA LOADS				KVA LOADS				LOAD DESCRIPTION		NOTES	
NOTES	LOAD DESCRIPTION	P	AMP	CCT	PH A	PH B	PH C	CCT	AMP	P					
	X RECEPT - A/V CLOSET 320	1	20 A	1	0.50	0.50		2	20 A	1			ACCESS CONTROL POWER SUPPLY	XRW	
	X SMOKE DAMPER 2ND FLOOR	1	20 A	3		0.50	0.36	4	20 A	1			A/V CLOSET 333 - RECEPT	X	
	X RECEPT - A/V CLOSET 325	1	20 A	5				0.72	0.00	6	20 A	1		EXISTING LOAD OR SPARE	X
	X RECEPT - A/V CLOSET 333	1	20 A	7	0.36	0.00		8	20 A	1			SPARE		
	X RECEPT - A/V CLOSET 325	1	20 A	9			0.36	0.00	10	20 A	1		SPARE		
	N.L. LCP2	1	20 A	11				0.50	0.00	12	20 A	1		SPARE	
	X SMOKE DAMPER 2ND FLOOR	1	20 A	13	0.50	0.00		14	20 A	1			SPARE		
	SPARE	1	20 A	15			0.00	0.00	16	20 A	1		SPARE		
				17				3.00	0.00	18	20 A	1		SPARE	
	X BREAK ROOM RANGE	2	40 A	19	3.00	--		20	--	1			SPACE		
	SPACE	1	--	21		--	--	22	--	1			SPACE		
	SPACE	1	--	23			--	--	24	--	1		SPACE		
	SPACE	1	--	25	--	--		26	--	1			SPACE		
	SPACE	1	--	27		--	--	28	--	1			SPACE		
	SPACE	1	--	29			--	--	30	--	1		SPACE		
				CONNECTED AMPS:		28.59	4.86	1.22	4.22	CONNECTED KVA:		10.30			
				DEMAND LOAD AMPS:		28.59				DEMAND KVA:		10.30			
	NOTES:														

McHenry & Associates Incorporated
MC&A
 Consulting Engineers est. 1960
 25001 Emery Road, Suite #200
 Warrensville Heights, Ohio 44128
 Phone: 216-292-4696
 Fax: 216-292-5874
 Email: mail@mchenryassociates.com

City of Kalamazoo - Crosstown Facility
 CPED & KDPS Workplace Renovation
 150 E Crosstown Parkway Kalamazoo MI 49001

Seal:

BID Set 08/21/2025
 © 2025, intersect studio, llc
 Project Number: 23-046

ELECTRICAL PANEL SCHEDULES

E608

GENERAL NOTES (TYPICAL ALL PANEL SCHEDULES)

- A. PROVIDE NEW AND/OR REUSE EXISTING CIRCUIT BREAKERS TO MATCH PANEL SCHEDULES SHOWN FOR EXISTING PANELS TO BE REUSED. MATCH PANEL TYPE, MANUFACTURER, AND U.L. RATINGS.

PANEL SCHEDULE NOTES (TYPICAL ALL PANEL SCHEDULES)

- CA # INDICATES CIRCUIT CONTROLLED BY CONTACTOR
- G # INDICATES 5 MA TRIP GFCI TYPE CIRCUIT BREAKER
- GE # INDICATES 30 MA TRIP GFCI TYPE CIRCUIT BREAKER
- L # INDICATES LOCK-ON CIRCUIT BREAKER
- ST # INDICATES SHUNT TRIP CIRCUIT BREAKER WITH 120 VOLT COIL
- X # INDICATES EXISTING CIRCUIT TO REMAIN
- N # INDICATES NEW CIRCUIT BREAKER TO BE INSTALLED MATCHING EXISTING PANEL LISTING
- XRW # INDICATES EXISTING CIRCUIT BREAKER SHALL BE USED FOR NEW CIRCUIT OR MADE SPARE FOLLOWING DEMOLITION
- XRL # INDICATES ADJUST EXISTING CIRCUIT BREAKER LOCATIONS AS REQUIRED FOR NEW 100A-3P CIRCUIT BREAKER

PANEL LP3		VOLTAGE: 480/277 Wye		PH & WIRES: 3PH,4W		BUSSING... 125		MAINS TYPE: LUGS ONLY		AIC RATING: EXISTING		MOUNTING: SURFACE		LOCATION: ELECTRICAL 344		FEEDER AMPACITY: EXISTING		REMARKS: EXISTING PANEL TO REMAIN MODIFY AS INDICATED	
NOTES	LOAD DESCRIPTION	P	AMP	CCT	KVA LOADS			CCT	AMP	P	LOAD DESCRIPTION	NOTES							
					PH A	PH B	PH C												
XRW	LIGHTING - CPED WEST & SOUTH	1	20 A	1	2.61	0.00		2	20 A	1	SPARE								
XRW	SPARE	1	20 A	3		0.00	0.00		4	20 A	1	SPARE							
XRW	SPARE	1	20 A	5					6	--	1	SPACE							
XRW	SPARE	1	20 A	7	0.00	--			8	--	1	SPACE							
XRW	SPARE	1	20 A	9		0.00	--		10	--	1	SPACE							
XRW	SPARE	1	20 A	11			0.00	--	12	--	1	SPACE							
XRW	SPARE	1	20 A	13	0.00	--			14	--	1	SPACE							
XRW	LIGHTING - COMMUNITY ROOM	1	20 A	15		1.20	--		16	--	1	SPACE							
XRW	SPARE	1	20 A	17			0.00	--	18	--	1	SPACE							
XRW	SPARE	1	20 A	19	0.00	--			20	--	1	SPACE							
XRW	SPARE	1	20 A	21		0.00	--		22	--	1	SPACE							
XRW	LIGHTING - CPED EAST & NORTH	1	20 A	23			1.30	--	24	--	1	SPACE							
XRW	SPARE	1	20 A	25	0.00	--			26	--	1	SPACE							
XRW	LIGHTING - CPED CORRIDORS	1	20 A	27		1.36	--		28	--	1	SPACE							
	SPACE	1	--	29			--	--	30	--	1	SPACE							
				CONNECTED AMPS:	7.78	2.61	2.56	1.30	CONNECTED KVA: 6.47										
				DEMAND LOAD AMPS:	7.78				DEMAND KVA: 6.47										
NOTES:																			

PANEL RP3B		VOLTAGE: 120/208 Wye		PH & WIRES: 3PH,4W		BUSSING... 125		MAINS TYPE: LUGS ONLY		AIC RATING: MATCH PANEL 'RP3'		MOUNTING: SURFACE		LOCATION: ELEC 243		FEEDER AMPACITY: 95		REMARKS:	
NOTES	LOAD DESCRIPTION	P	AMP	CCT	KVA LOADS			CCT	AMP	P	LOAD DESCRIPTION	NOTES							
					PH A	PH B	PH C												
G	VENDING MACHINE - ROOM 195	1	20 A	1	1.20	1.08		2	20 A	1	ROOM 261, 262 - RECEIPT								
	VENDING MACHINE - ROOM 195	1	20 A	3		1.20	0.90		4	20 A	1	ROOM 257, 259 - RECEIPT							
	VENDING MACHINE - ROOM 195	1	20 A	5					6	20 A	1	ROOM 258 - RECEIPT							
	RECEIPT - ROOM 194	1	20 A	7	0.54	0.72			8	20 A	1	ROOM 258 - RECEIPT							
	RECEIPT - ROOM 195	1	20 A	9		1.26	0.90		10	20 A	1	ROOM 215, 218 - RECEIPT							
G	REFRIGERATOR - ROOM 196	1	20 A	11			0.50	0.68		12	20 A	1	ROOM 219 - RECEIPT						
G	FREEZER - ROOM 196	1	20 A	13	0.50	0.72			14	20 A	1	ROOM 216 - RECEIPT							
G	DISHWASHER - ROOM 196	1	20 A	15		0.50	0.72		16	20 A	1	ROOM 255 - RECEIPT							
G	DISPOSAL - ROOM 196	1	20 A	17			0.70	0.54		18	20 A	1	ROOM 256 - RECEIPT						
G	U.C. ICE MAKER - ROOM 196	1	20 A	19	0.50	0.50			20	20 A	1	LIT SIGNAGE							
G	MICROWAVE - ROOM 196	1	20 A	21		1.20	0.50		22	20 A	1	LIGHTBOX							
G	MICROWAVE - ROOM 196	1	20 A	23			1.20	0.05		24	20 A	1	WORK CAFE SCONCE - LIGHT						
G	RECEIPT - ROOM 196	1	20 A	25	0.54	0.00			26	20 A	1	SPARE							
G	HOOD - ROOM 196	1	20 A	27		0.50	0.00		28	20 A	1	SPARE							
G	RANGE - ROOM 196	2	50 A	29			1.82	0.00	30	20 A	1	SPARE							
				31	1.82	0.00			32	20 A	1	SPARE							
	(3) TV'S	1	20 A	33		0.75	0.00		34	20 A	1	SPARE							
	CUH-04 & CUH-05	1	15 A	35			0.20	0.00	36	20 A	1	SPARE							
	RECEIPT - ROOM 260, 263	1	20 A	37	0.90	--			38	--	1	SPACE							
	(2) TV'S	1	20 A	39		0.50	--		40	--	1	SPACE							
	RECEIPT - ROOM 261	1	20 A	41			0.72	--	42	--	1	SPACE							
				CONNECTED AMPS:	73.94	9.02	8.93	8.69	CONNECTED KVA: 26.64										
				DEMAND LOAD AMPS:	59.72				DEMAND KVA: 21.52										
NOTES: PROVIDE SOLID NEUTRAL BUS & GROUND BAR. PROVIDE LUG SIZES AS REQUIRED FOR FEEDER SIZE SHOWN ON PARTIAL ONE-LINE DIAGRAM																			

PANEL RP6		VOLTAGE: 120/208 Wye		PH & WIRES: 3PH,4W		BUSSING... 225		MAINS TYPE: 225A M.C.B.		AIC RATING: EXISTING		MOUNTING: SURFACE		LOCATION: ELECTRICAL 344		FEEDER AMPACITY: 225		REMARKS: EXISTING PANEL TO REMAIN MODIFY AS INDICATED	
NOTES	LOAD DESCRIPTION	P	AMP	CCT	KVA LOADS			CCT	AMP	P	LOAD DESCRIPTION	NOTES							
					PH A	PH B	PH C												
X	PANEL 'RP6B'	3	100 A	3	6.21	0.18		4	20 A	1	ROOM 336-C - PROJECTION SCREEN	XRW							
				5			6.07	0.72	6	20 A	1	ROOM 336, 336-B - RECEIPT	X						
XRW	ELLIPTICAL - ROOM 347	1	20 A	7	0.65	0.72			8	20 A	1	ROOM 334 - RECEIPT	X						
XRW	TREADMILL - ROOM 347	1	20 A	9		1.50	0.72		10	20 A	1	ROOM 341 - RECEIPT	X						
XRW	TREADMILL - ROOM 347	1	20 A	11			1.50	0.54	12	20 A	1	ROOM 336-B - RECEIPT	XRW						
X	RECEIPT - ROOM 347	1	20 A	13	0.54	0.36			14	20 A	1	ROOM 341 - RECEIPT	X						
XRW	TREADMILL - ROOM 347	1	20 A	15		1.50	0.90		16	20 A	1	ROOM 343 - RECEIPT	X						
X	RECEIPT - ROOM 336, 336-C	1	20 A	17			0.90	0.50	18	20 A	2	EXISTING LOAD OR SPARE	X						
X	FLOOR RECEIPT - ROOM 336-C	1	20 A	19	0.36	0.50			20	20 A	2	EXISTING LOAD OR SPARE	X						
X	FLOOR RECEIPT - ROOM 336-C	1	20 A	21		0.36	0.50		22	20 A	2	EXISTING LOAD OR SPARE	X						
X	RECEIPT - ROOM 336, 336-C	1	20 A	23			0.90	0.50	24	20 A	2	EXISTING LOAD OR SPARE	X						
X	RECEIPT - ROOM 326, 327, 328	1	20 A	25	0.54	0.36			26	20 A	1	ROOM 367 - RECEIPT	XRW						
XRW	LIT SIGNAGE	1	20 A	27		0.50	0.72		28	20 A	1	ROOM 339 - RECEIPT	X						
X	RECEIPT - ROOM 329, 331	1	20 A	29			0.54	0.50	30	20 A	1	TOILET SENSORS	X						
XRW	STAIR CLIMBER - ROOM 347	1	20 A	31	0.65	0.20			32	20 A	1	EWG	X						
X	RECEIPT - ROOM 336-B	1	20 A	33		0.36	0.50		34	20 A	1	ROOM 33X - FUTURE REFRIGERATOR	N,G						
XRW	PROJECTION SCREEN - ROOM 336	1	20 A	35			0.18	0.75	36	20 A	1	(3) TV'S	XRW						
X	FLOOR RECEIPT - ROOM 336-B	1	20 A	37	0.18	0.75			38	20 A	1	(3) TV'S	XRW						
XRW	FUTURE RECEIPT - ROOM 347	1	20 A	39		1.00	0.50		40	20 A	1	TCP	X						
XRW	PROJECTION SCREEN - ROOM 336-B	1	20 A	41			0.18	--	42	--	1	SPACE							
				CONNECTED AMPS:	112.19	12.20	14.43	13.78	CONNECTED KVA: 40.42										
				DEMAND LOAD AMPS:	96.37				DEMAND KVA: 34.72										
NOTES:																			

PANEL RP6B		VOLTAGE: 120/208 Wye		PH & WIRES: 3PH,4W		BUSSING... 100		MAINS TYPE: 100A M.C.B.		AIC RATING: EXISTING		MOUNTING: SURFACE		LOCATION: ELECTRICAL 344		FEEDER AMPACITY: 95		REMARKS: EXISTING PANEL TO REMAIN MODIFY AS INDICATED	
NOTES	LOAD DESCRIPTION	P	AMP	CCT	KVA LOADS			CCT	AMP	P	LOAD DESCRIPTION	NOTES							
					PH A	PH B	PH C												
X	EXISTING LOAD OR SPARE	2	30 A	1	1.00	0.72		2	20 A	1	ROOM 388 - RECEIPT	X							
X	RECEIPT - ROOM 374	1	20 A	5		1.00	0.72		4	20 A	1	ROOM 389 - RECEIPT	X						
X	RECEIPT - ROOM 374, 375	1	20 A	7	0.72	0.36		0.72	1.44	6	20 A	1	ROOM 364 - RECEIPT	X					
X	RECEIPT - ROOM 377	1	20 A	9		0.36	0.36		8	20 A	1	ROOM 382 - RECEIPT	X						
X	RECEIPT - ROOM 377	1	20 A	11				0.36	0.36	10	20 A	1	ROOM 392 - RECEIPT	X					
X	RECEIPT - ROOM 377	1	20 A	13	0.36	0.36			12	20 A	1	ROOM 392 - SCREEN	X						
X	RECEIPT - ROOM 377	1	20 A	15		0.36	0.50		14	20 A	1	ROOM 392 - RECEIPT	X						
X	RECEIPT - ROOM 377	1	20 A	17			0.36	0.50	16	20 A	1	ROOM 336-C - PROJECTOR	XRW						
X	RECEIPT - ROOM 377 & EWG	1	20 A	19	0.50	0.50			18	20 A	1	ROOM 336 - PROJECTOR	XRW						
X	EXISTING LOAD OR SPARE	1	20 A	21		0.00	0.00		20	20 A	1	ROOM 336-B - PROJECTOR	XRW						
X	EXISTING LOAD OR SPARE	1	20 A	23			0.00	1.15	22	20 A	1	SPARE							
X	RECEIPT - ABOVE SINK ROOM 379	1	20 A	25	0.54	1.15			24	20 A	3	(2) OPERABLE PARTITIONS	N						
X	RECEIPT - ROOM 383	1	20 A	27		0.72	1.15		26	20 A	1	TOILET SENSORS	X						
X	RECEIPT - ROOM 387, 388, HALL	1	20 A	29			1.08	0.10	28	20 A	1	TOILET SENSORS	X						
				CONNECTED AMPS:	48.46	6.21	5.17	6.07	CONNECTED KVA: 17.46										
				DEMAND LOAD AMPS:	48.46				DEMAND KVA: 17.46										
NOTES:																			

McHenry & Associates Incorporated
MC&A
 Consulting Engineers est. 1960
 25001 Emery Road, Suite #200
 Warrensville Heights, Ohio 44128
 Phone: 216-292-4696
 Fax: 216-292-5874
 Email: mail@mchenryassociates.com

City of Kalamazoo - Crosstown Facility
 CPED & KDPS Workplace Renovation
 150 E Crosstown Parkway Kalamazoo MI 49001

Seal:

BID Set 08/21/2025
 © 2025, intersect studio, llc
 Project Number: 23-046

ELECTRICAL PANEL SCHEDULES

E609

GENERAL NOTES (TYPICAL ALL PANEL SCHEDULES)

- A. PROVIDE NEW AND/OR REUSE EXISTING CIRCUIT BREAKERS TO MATCH PANEL SCHEDULES SHOWN FOR EXISTING PANELS TO BE REUSED. MATCH PANEL TYPE, MANUFACTURER, AND U.L. RATINGS.

PANEL SCHEDULE NOTES (TYPICAL ALL PANEL SCHEDULES)

- CA # INDICATES CIRCUIT CONTROLLED BY CONTACTOR
- G # INDICATES 5 MA TRIP GFCI TYPE CIRCUIT BREAKER
- GE # INDICATES 30 MA TRIP GFCI TYPE CIRCUIT BREAKER
- L # INDICATES LOCK-ON CIRCUIT BREAKER
- ST # INDICATES SHUNT TRIP CIRCUIT BREAKER WITH 120 VOLT COIL
- X # INDICATES EXISTING CIRCUIT TO REMAIN
- N # INDICATES NEW CIRCUIT BREAKER TO BE INSTALLED MATCHING EXISTING PANEL LISTING
- XRW # INDICATES EXISTING CIRCUIT BREAKER SHALL BE USED FOR NEW CIRCUIT OR MADE SPARE FOLLOWING DEMOLITION
- XRL # INDICATES ADJUST EXISTING CIRCUIT BREAKER LOCATIONS AS REQUIRED FOR NEW 100A-3P CIRCUIT BREAKER

PANEL ELP1		VOLTAGE: 480/277 Wye		PH & WIRES: 3PH,4W		BUSSING... 125		MAINS TYPE: LUGS ONLY		AIC RATING: EXISTING		MOUNTING: SURFACE		LOCATION: ELECTRICAL 308		FEEDER AMPACITY: 60		REMARKS: EXISTING EM PANEL TO REMAIN MODIFY AS INDICATED	
NOTES	LOAD DESCRIPTION	P	AMP	CCT	KVA LOADS			CCT	AMP	P	LOAD DESCRIPTION	NOTES							
					PH A	PH B	PH C												
X	PANEL 'ELP3'	3	40 A	3	1.28	1.33		2	40 A	3	PANEL 'ELP1' X								
				5				6											
				7	1.98	--		8											
X	PANEL 'ELP2'	3	40 A	9		1.89	--	10	--	3	PANEL 'ELP4' X								
				11			1.00	12											
	SPACE	1	--	13	--	--		14	--	1	SPACE								
	SPACE	1	--	15				16	--	1	SPACE								
	SPACE	1	--	17				18	--	1	SPACE								
				CONNECTED AMPS:	17.40	4.59	7.65	2.24	CONNECTED KVA:	14.47									
				DEMAND LOAD AMPS:	17.40				DEMAND KVA:	14.47									
NOTES:																			

PANEL ELP2		VOLTAGE: 480/277 Wye		PH & WIRES: 3PH,4W		BUSSING... 125		MAINS TYPE: LUGS ONLY		AIC RATING: EXISTING		MOUNTING: SURFACE		LOCATION: ELEC 243		FEEDER AMPACITY: 40		REMARKS: EXISTING EM PANEL TO REMAIN MODIFY AS INDICATED	
NOTES	LOAD DESCRIPTION	P	AMP	CCT	KVA LOADS			CCT	AMP	P	LOAD DESCRIPTION	NOTES							
					PH A	PH B	PH C												
XRW	EM/NL LIGHTING - KDPS	1	20 A	1	0.66	0.32		2	20 A	1	EXTERIOR LIGHTS N								
X	LIGHTING - ROOM 192,200,211	1	20 A	3			1.00	--	4	--	1	SPACE							
X	LIGHTING - ROOM 187, 196	1	20 A	5				1.00	--	1	SPACE								
X	LIGHTING - HALLWAYS	1	20 A	7	1.00	--		8	--	1	SPACE								
N	EM LIGHTING - KDPS	1	20 A	9		0.89	--	10	--	1	SPACE								
	SPARE	1	20 A	11				0.00	--	12	SPACE								
	SPACE	1	--	13	--	--		14	--	1	SPACE								
	SPACE	1	--	15				16	--	1	SPACE								
	SPACE	1	--	17				18	--	1	SPACE								
				CONNECTED AMPS:	5.87	1.98	1.89	1.00	CONNECTED KVA:	4.88									
				DEMAND LOAD AMPS:	5.87				DEMAND KVA:	4.88									
NOTES:																			

PANEL ELP1		VOLTAGE: 480/277 Wye		PH & WIRES: 3PH,4W		BUSSING... 60		MAINS TYPE: 60A M.C.B.		AIC RATING: EXISTING		MOUNTING: SURFACE		LOCATION: ELEC 121		FEEDER AMPACITY: 55		REMARKS: EXISTING EM PANEL TO REMAIN MODIFY AS INDICATED	
NOTES	LOAD DESCRIPTION	P	AMP	CCT	KVA LOADS			CCT	AMP	P	LOAD DESCRIPTION	NOTES							
					PH A	PH B	PH C												
XRW	EM/NL LIGHTING - CPED	1	20 A	1	1.33	0.00		2	20 A	1	SPARE								
XRW	EM LIGHTING - CPED	1	20 A	3		2.38	0.00	4	20 A	1	SPARE								
	SPARE	1	20 A	5			0.00	0.00	6	20 A	1	SPARE							
XRW	SPARE	1	20 A	7	0.00	--		8	--	1	SPACE								
XRW	SPARE	1	20 A	9		0.00	--	10	--	1	SPACE								
XRW	SPARE	1	20 A	11			0.00	--	12	--	1	SPACE							
	SPACE	1	--	13	--	--		14	--	1	SPACE								
	SPACE	1	--	15				16	--	1	SPACE								
	SPACE	1	--	17				18	--	1	SPACE								
				CONNECTED AMPS:	4.46	1.33	2.38	0.00	CONNECTED KVA:	3.71									
				DEMAND LOAD AMPS:	4.46				DEMAND KVA:	3.71									
NOTES:																			

PANEL ELP3		VOLTAGE: 480/277 Wye		PH & WIRES: 3PH,4W		BUSSING... 125		MAINS TYPE: LUGS ONLY		AIC RATING: EXISTING		MOUNTING: SURFACE		LOCATION: ELECTRICAL 308		FEEDER AMPACITY: 40		REMARKS: EXISTING EM PANEL TO REMAIN MODIFY AS INDICATED	
NOTES	LOAD DESCRIPTION	P	AMP	CCT	KVA LOADS			CCT	AMP	P	LOAD DESCRIPTION	NOTES							
					PH A	PH B	PH C												
XRW	EM/NL LIGHTING - CPED	1	20 A	1	1.28	0.00		2	20 A	1	SPARE								
XRW	EM LIGHTING - CPED NORTH	1	20 A	3		3.37	0.00	4	20 A	1	SPARE								
XRW	EM LIGHTING - CPED SOUTH	1	20 A	5			1.24	0.00	6	20 A	1	SPARE							
	SPARE	1	20 A	7	0.00	--		8	--	1	SPACE								
	SPACE	1	--	9	--	--		10	--	1	SPACE								
	SPACE	1	--	11			--	--	12	--	1	SPACE							
	SPACE	1	--	13	--	--		14	--	1	SPACE								
	SPACE	1	--	15			--	--	16	--	1	SPACE							
	SPACE	1	--	17			--	--	18	--	1	SPACE							
				CONNECTED AMPS:	7.08	1.28	3.37	1.24	CONNECTED KVA:	5.89									
				DEMAND LOAD AMPS:	7.08				DEMAND KVA:	5.89									
NOTES:																			

PANEL ELP5		VOLTAGE: 480/277 Wye		PH & WIRES: 3PH,4W		BUSSING... 125		MAINS TYPE: 50A M.C.B.		AIC RATING: EXISTING		MOUNTING: SURFACE		LOCATION: ELEC 243		FEEDER AMPACITY: 50		REMARKS: EXISTING EM PANEL TO REMAIN MODIFY AS INDICATED	
NOTES	LOAD DESCRIPTION	P	AMP	CCT	KVA LOADS			CCT	AMP	P	LOAD DESCRIPTION	NOTES							
					PH A	PH B	PH C												
X	LIGHTING - ROOM 209, 246, 247	1	20 A	1	1.00	--		2	--	1	SPACE								
X	LIGHTING - ROOM 224	1	20 A	3		1.00	--	4	--	1	SPACE								
X	LIGHTING - ROOM...	1	20 A	5			1.00	--	6	--	1	SPACE							
				7	16.24	--		8	--	1	SPACE								
X	PANEL 'ERP5' (VIA 45KVA XFMR)	3	50 A	9		16.24	--	10	--	1	SPACE								
				11			11.60	--	12	--	1	SPACE							
	SPACE	1	--	13	--	--		14	--	1	SPACE								
	SPACE	1	--	15				16	--	1	SPACE								
	SPACE	1	--	17				18	--	1	SPACE								
	SPACE	1	--	19	--	--		20	--	1	SPACE								
	SPACE	1	--	21			--	--	22	--	1	SPACE							
	SPACE	1	--	23			--	--	24	--	1	SPACE							
	SPACE	1	--	25	--	--		26	--	1	SPACE								
	SPACE	1	--	27			--	--	28	--	1	SPACE							
	SPACE	1	--	29			--	--	30	--	1	SPACE							
				CONNECTED AMPS:	56.63	17.24	17.24	12.60	CONNECTED KVA:	47.08									
				DEMAND LOAD AMPS:	56.63				DEMAND KVA:	47.08									
NOTES:																			

McHenry & Associates Incorporated
Mc&A
 Consulting Engineers est. 1960
 25001 Emery Road, Suite #200
 Warrensville Heights, Ohio 44128
 Phone: 216-292-4696
 Fax: 216-292-5874
 Email: mail@mchenryassociates.com

City of Kalamazoo - Crosstown Facility
 CPED & KDPS Workplace Renovation
 150 E Crosstown Parkway Kalamazoo MI 49001

Seal:

BID Set 08/21/2025
 © 2025, intersect studio, llc
 Project Number: 23-046

ELECTRICAL PANEL SCHEDULES

E610

LEGEND

GENERAL NOTES:

A. ALL HOMERUNS SHALL BE #12 AWG + GND IN 3/4" CONDUIT MINIMUM. INCREASE WIRE SIZE PER VOLTAGE DROP TABLE.

B. ALL LIGHTING CIRCUITS SHALL HAVE INDIVIDUAL NEUTRAL CONDUCTORS CONTINUOUS FROM PANEL.

C. THE EXACT LOCATION OF ALL LIGHT FIXTURES SHALL BE AS SHOWN ON THE ARCHITECT'S SITE PLAN.

VOLTAGE DROP SCHEDULE

120 VOLT BRANCH CIRCUITS UP TO 10 AMPS

TOTAL WIRE LENGTH (FEET)	WIRE SIZE (AWG)
1' - 100'	#12
101' - 150'	#10
151' - 240'	#8
241' - 350'	#6

120 VOLT BRANCH CIRCUITS UP TO 14 AMPS

TOTAL WIRE LENGTH (FEET)	WIRE SIZE (AWG)
1' - 75'	#12
76' - 115'	#10
116' - 155'	#8
156' - 240'	#6

277 VOLT BRANCH CIRCUITS UP TO 16 AMPS

TOTAL WIRE LENGTH (FEET)	WIRE SIZE (AWG)
1' - 140'	#12
141' - 225'	#10
226' - 345'	#8
346' - 546'	#6

MINIMUM BRANCH CIRCUIT WIRING IS #12 AWG. CONTRACTOR SHALL INCREASE WIRE SIZE BASED ON SCHEDULE ABOVE.

BRANCH CIRCUITING GENERAL NOTES

A. ON 20 AMP, 1 POLE CIRCUITS, HOMERUNS SHALL BE 2 #12 AWG + GND IN 3/4" CONDUIT MINIMUM. INCREASE WIRE SIZE PER VOLTAGE DROP TABLE.

B. ALL CIRCUITS SHALL HAVE INDIVIDUAL NEUTRAL CONDUCTORS CONTINUOUS FROM PANEL. SHARED NEUTRALS ARE NOT PERMITTED.

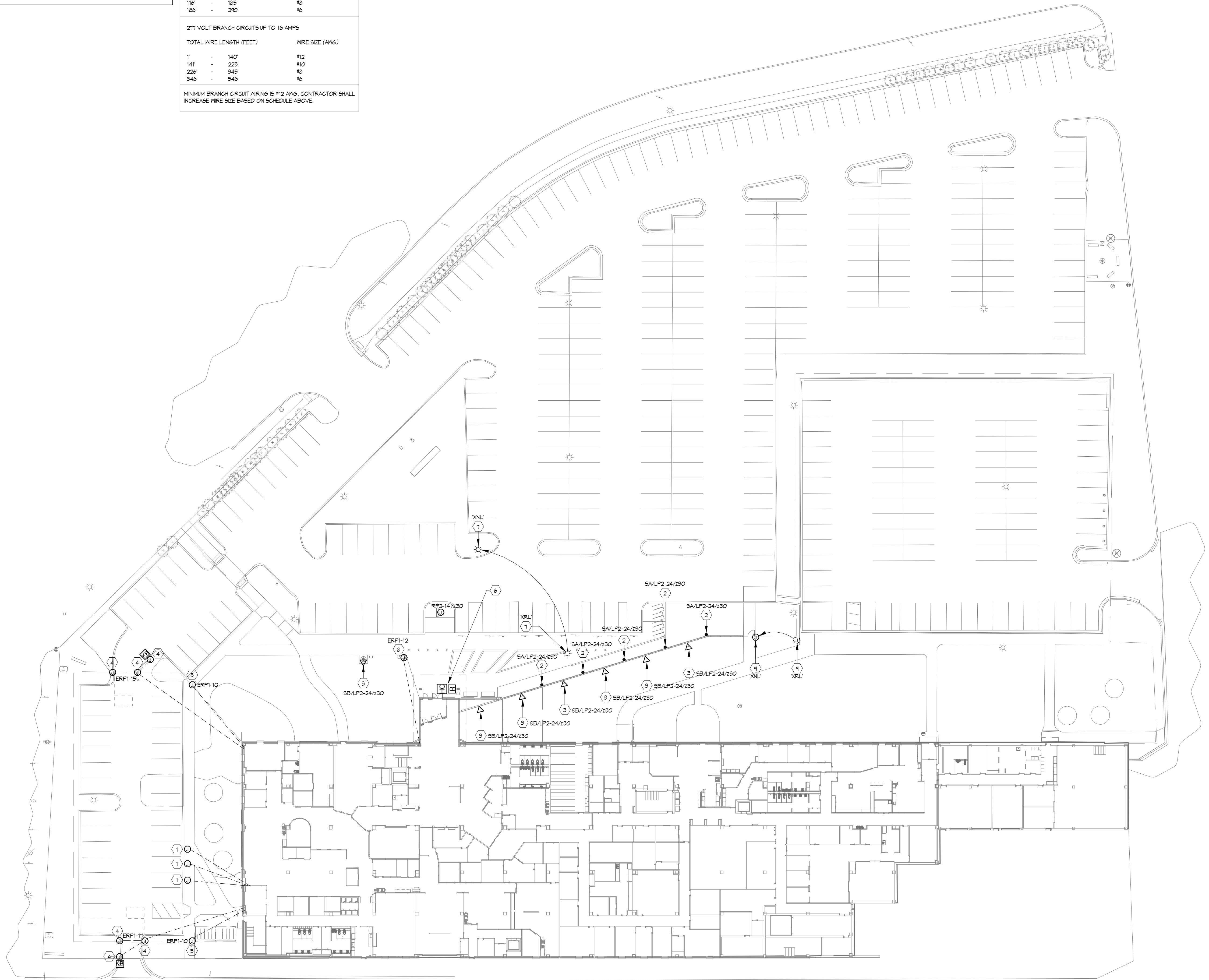
- CODED NOTES**
- PROVIDE 1-1/2" WITH PULLSTRING BELOW GRADE AND TERMINATE IN FLUSH WITH GRADE JUNCTION BOX. CONDUIT SHALL RISE UP IN NEW PARTITION WALL AND EXTEND TO JOIST SPACE. LABEL BOX AND CONDUIT AS FUTURE E.V.
 - SEE ARCHITECTURAL DRAWINGS FOR POLE BASE DETAIL. ELECTRICAL CONTRACTOR TO LOCATE EXISTING AND NEW UNDERGROUND UTILITIES PRIOR TO SETTING NEW POLE BASE.
 - FIXTURE TYPE 'SB' SHALL BE WALL MOUNTED ON VERTICAL SURFACE - CONCEAL ALL CONDUIT IN WALL.
 - FOR POWER AND DATA FEEDS TO NEW MOTORIZED ROLLING SECURITY GATE WITH CARD SCANNER, ROUTE CONDUITS BELOW GRADE AND THEN STUB UP IN NEW FULL HEIGHT PARTITION WALL. POWER CONDUIT TO HOMERUN TO INDICATED PANEL FROM THERE DATA CONDUIT TO BE STUBBED ABOVE CEILING, PROVIDED WITH GROMMET, PULLSTRING AND LABEL FOR USE BY LOW VOLTAGE INSTALLER. POWER CONDUIT TO BE 1-1/2" AND DATA CONDUIT TO BE 1". PROVIDE ALL WIRING AND FINAL CONNECTIONS FOR A COMPLETE, OPERABLE SYSTEM. PROVIDE GROUND LOOPS AS REQUIRED. REFER TO MANUFACTURER'S DETAILS.
 - FOR POWER AND DATA FEEDS TO NEW SECURE MAN GATE WITH KEY CARD ACCESS, ROUTE CONDUITS BELOW GRADE AND THEN STUB UP IN NEW FULL HEIGHT PARTITION WALL. POWER CONDUIT TO HOMERUN TO INDICATED PANEL FROM THERE DATA CONDUIT TO BE STUBBED ABOVE CEILING, PROVIDED WITH GROMMET, PULLSTRING AND LABEL FOR USE BY LOW VOLTAGE INSTALLER. POWER CONDUIT TO BE 1-1/2" AND DATA CONDUIT TO BE 1". PROVIDE ALL WIRING AND FINAL CONNECTIONS FOR A COMPLETE, OPERABLE SYSTEM.
 - EXTERIOR ACTUATOR AND CARD READER LOCATED ON POST. REFER TO DRAWING E200 FOR DETAILS.
 - EXISTING LIGHTPOST SHALL BE RELOCATED TO APPROXIMATE NEW LOCATION AS SHOWN BY E.C. EXTEND EXISTING POWER AND CONTROLS TO NEW LOCATION. REFER TO ARCHITECTURAL DRAWINGS FOR ADDITIONAL INFORMATION.
 - FOR POWER AND DATA FEEDS TO NEW EMERGENCY CALL PEDESTAL WITH BLUE LIGHT, ROUTE CONDUITS BELOW GRADE AND THEN STUB UP IN NEW FULL HEIGHT PARTITION WALL. POWER CONDUIT TO HOMERUN TO INDICATED PANEL FROM THERE DATA CONDUIT TO BE STUBBED ABOVE CEILING, PROVIDED WITH GROMMET, PULLSTRING AND LABEL FOR USE BY LOW VOLTAGE INSTALLER. POWER CONDUIT TO BE 1-1/2" AND DATA CONDUIT TO BE 1". PROVIDE ALL WIRING AND FINAL CONNECTIONS FOR A COMPLETE, OPERABLE SYSTEM.
 - EXISTING MAN GATE SHALL BE RELOCATED TO APPROXIMATE NEW LOCATION AS SHOWN BY G.C. E.G. SHALL EXTEND EXISTING POWER AND CONTROLS TO NEW LOCATION. REFER TO ARCHITECTURAL DRAWINGS FOR ADDITIONAL INFORMATION.

McHenry & Associates Incorporated

Mc&A

Consulting Engineers est. 1960

25001 Emory Road, Suite #200
 Warrensville Heights, Ohio 44128
 Phone: 216-292-4696
 Fax: 216-292-5874
 Email: mail@mcHenryassociates.com



NOTE:
 ANY EXTERIOR LIGHT FIXTURES NOT CALLED OUT AS NEW OR RELOCATED ARE EXISTING TO REMAIN.

1 ELECTRICAL SITE PLAN
 ES101 1" = 30'-0"

City of Kalamazoo - Crosstown Facility
 CPED & KDPS Workplace Renovation
 150 E Crosstown Parkway Kalamazoo MI 49001

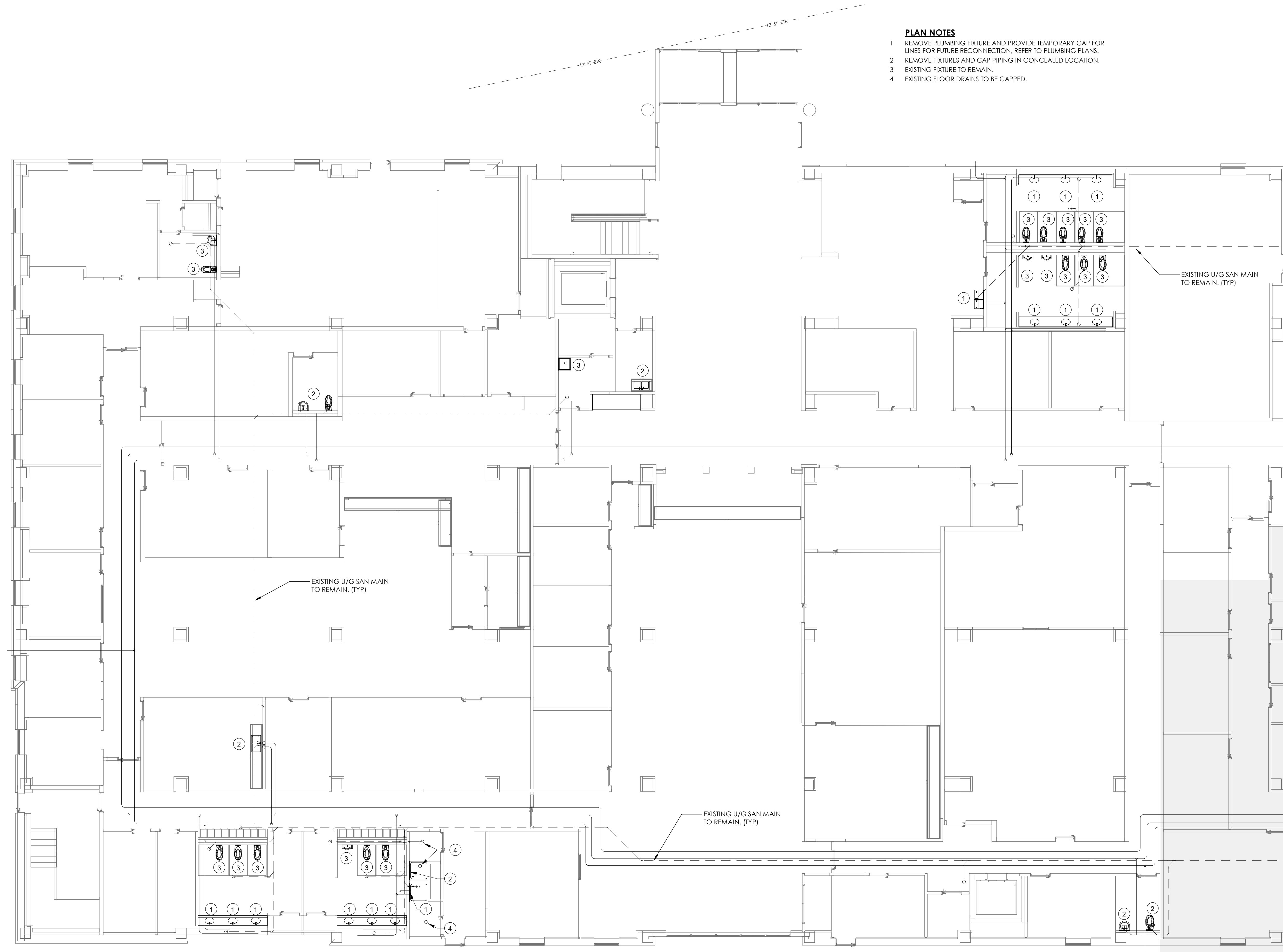
Seal:

BID Set 08/21/2025
 © 2025, intersect studio, llc
 Project Number: 23-046

ELECTRICAL SITE PLAN

ES101

8/07/2025 9:52:15 D:\02\Bentley\4531_WEP_205_McHenry\ES101.dwg



- PLAN NOTES**
- 1 REMOVE PLUMBING FIXTURE AND PROVIDE TEMPORARY CAP FOR LINES FOR FUTURE RECONNECTION, REFER TO PLUMBING PLANS.
 - 2 REMOVE FIXTURES AND CAP PIPING IN CONCEALED LOCATION.
 - 3 EXISTING FIXTURE TO REMAIN.
 - 4 EXISTING FLOOR DRAINS TO BE CAPPED.

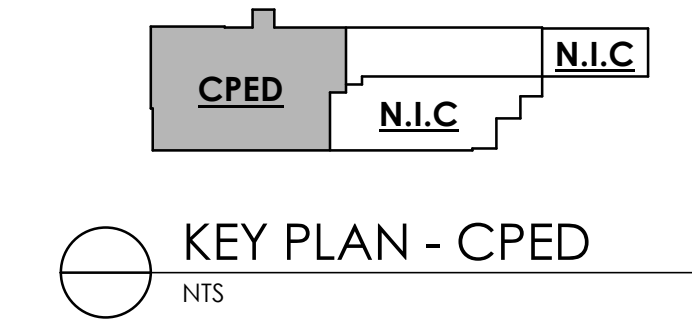
City of Kalamazoo - Crosstown Facility
 CPED & KDPS Workplace Renovation
 150 E Crosstown Parkway Kalamazoo MI 49001

NOT FOR
 Seal:
 REGULATORY
 APPROVAL,
 PERMITTING,
 OR
 CONSTRUCTION

Bid 08/21/2025
 © 2025, intersect studio, llc
 Project Number: 23-046

**MAIN LEVEL CPED
 PLUMBING DEMO
 PLAN**

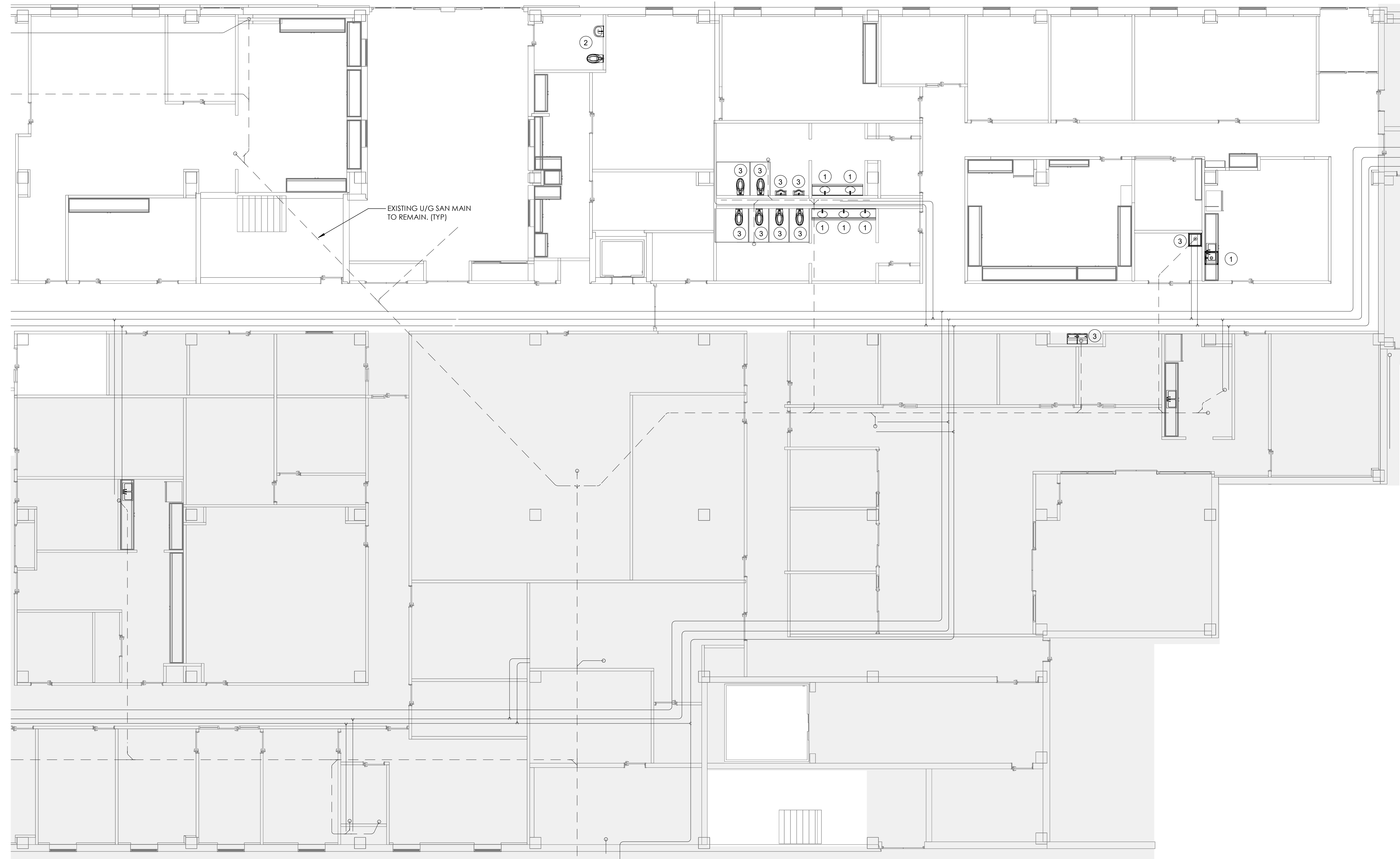
1 MAIN LEVEL CPED PLUMBING DEMO PLAN
 PD100 1/8" = 1'-0"



PD100

PLAN NOTES

- 1 REMOVE PLUMBING FIXTURE AND PROVIDE TEMPORARY CAP FOR LINES FOR FUTURE RECONNECTION. REFER TO PLUMBING PLANS.
- 2 REMOVE FIXTURES AND CAP PIPING IN CONCEALED LOCATION.
- 3 EXISTING FIXTURE TO REMAIN.



City of Kalamazoo - Crosstown Facility
CPED & KDPS Workplace Renovation
150 E Crosstown Parkway Kalamazoo MI 49001

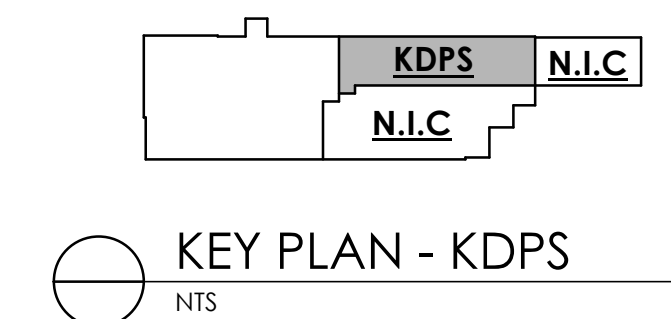
NOT FOR
REGULATORY
APPROVAL,
PERMITTING,
OR
CONSTRUCTION

Bid 08/21/2025
© 2025, intersect studio, llc
Project Number: 23-046

MAIN LEVEL KDPS
PLUMBING DEMO
PLAN

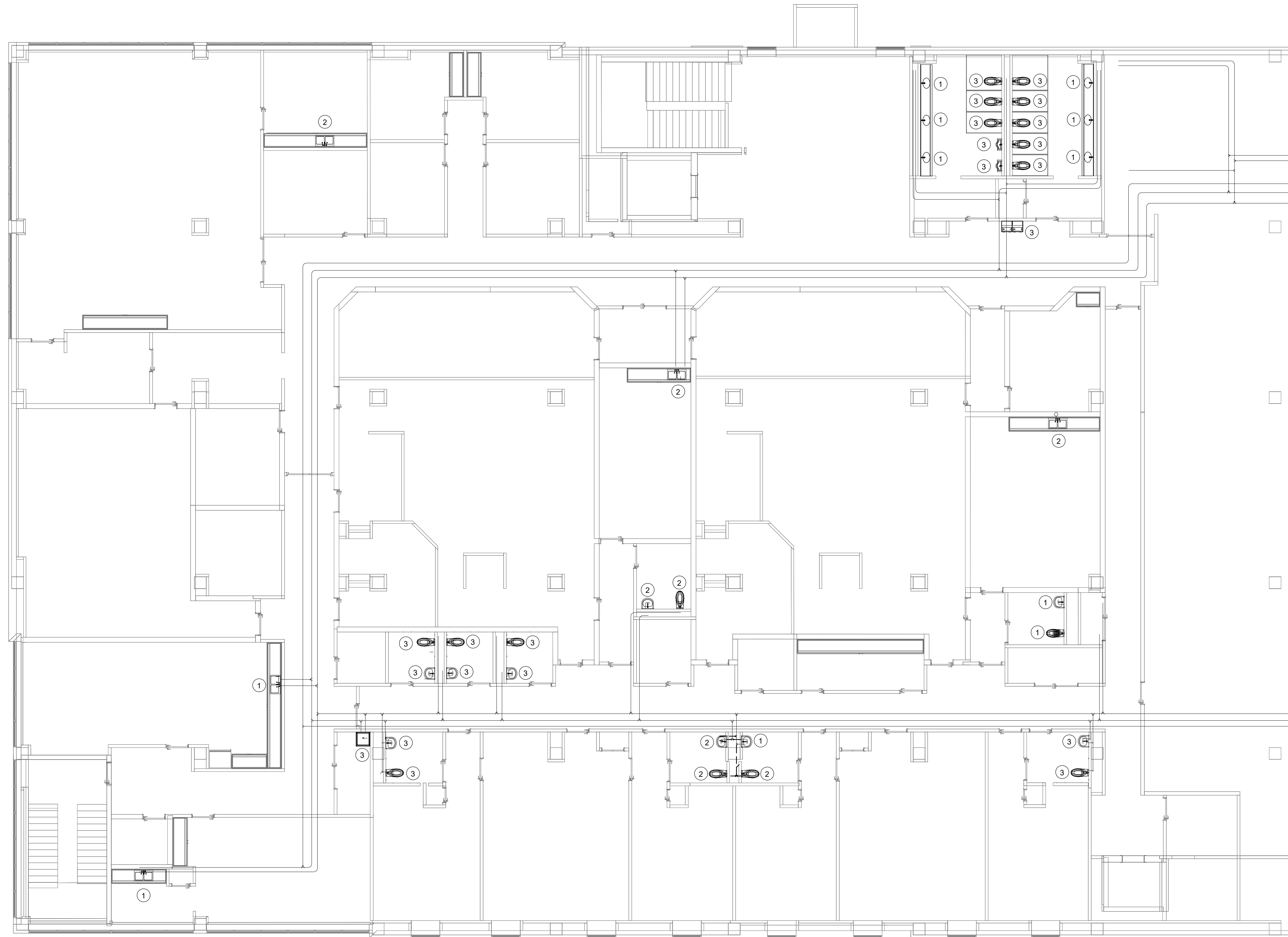
PD101

1 MAIN LEVEL KDPS PLUMBING DEMO PLAN
1/8" = 1'-0"



PLAN NOTES

- 1 REMOVE PLUMBING FIXTURE AND PROVIDE TEMPORARY CAP FOR LINES FOR FUTURE RECONNECTION, REFER TO PLUMBING PLANS.
- 2 REMOVE FIXTURES AND CAP PIPING IN CONCEALED LOCATION.
- 3 EXISTING FIXTURE TO REMAIN.



City of Kalamazoo - Crosstown Facility
CPED & KDPS Workplace Renovation
150 E Crosstown Parkway Kalamazoo MI 49001

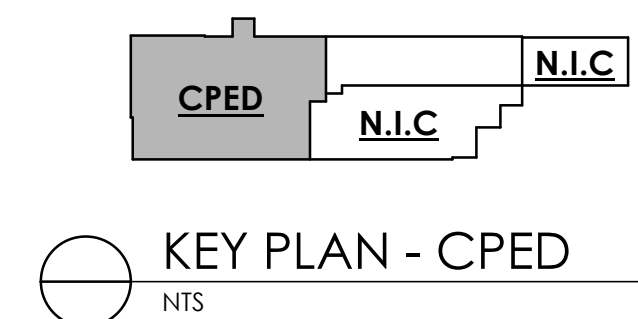
NOT FOR
REGULATORY
APPROVAL,
PERMITTING,
OR
CONSTRUCTION

Bid 08/21/2025
© 2025, intersect studio, llc
Project Number: 23-046

UPPER LEVEL CPED
PLUMBING DEMO
PLAN

PD102

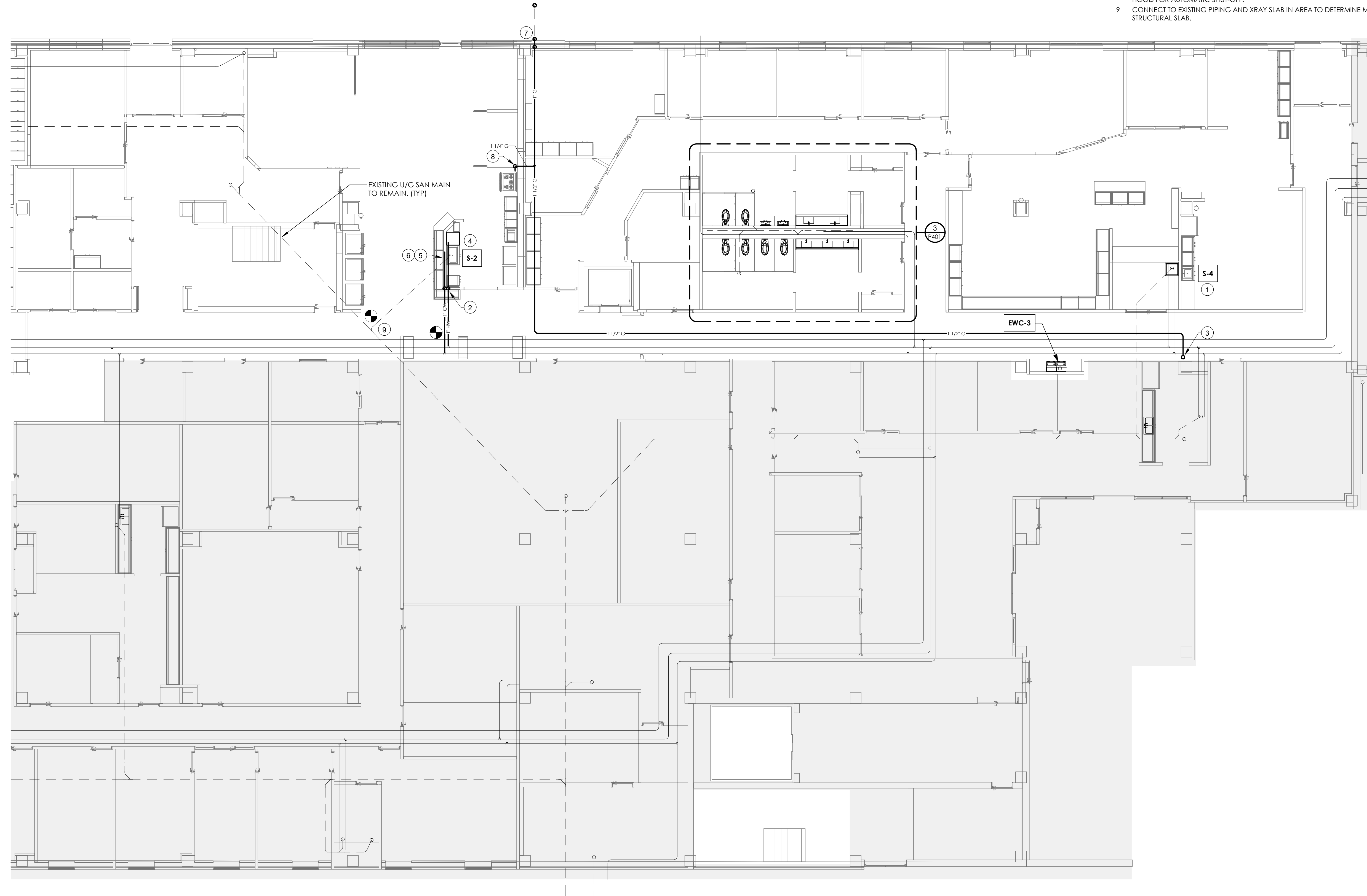
1 UPPER LEVEL CPED PLUMBING DEMO PLAN
1/8" = 1'-0"



GENERAL NOTE:
 THE EXISTING FIRST FLOOR IS A STRUCTURAL 2-WAY SLAB SPANNING COLUMN LINE TO COLUMN LINE. AND PENETRATIONS AND LOADING SHALL BE LIMITED. SEE S100 AND S101 FOR NOTES.

PLAN NOTES

- 1 CONNECT FIXTURE TO EXISTING TO REMAIN PIPING WITHIN WALL. FIELD VERIFY EXACT CONNECTIONS.
- 2 CONNECT TO EXISTING PIPING AND COME DOWN IN ISLAND WALL.
- 3 1-1/2" NG UP TO FLOOR ABOVE. REFER TO P103 FOR CONTINUATION.
- 4 CONNECT CW/HW CONNECTIONS FOR SINK. ROUTE 1/2" HW UNDER COUNTER TO DISHWASHER, 1/2" CW TO UNDER COUNTER POINT OF USE WATER FILTER TO SERVE FILTERED WATER FAUCET.
- 5 PROVIDE 1/2" CW CONNECTIONS FOR COUNTER TOP COFFEE MAKER & FOR UNDER COUNTER ICE MACHINE. BOTH CONNECTIONS TO INCLUDE WATTS MODEL 9DM3 (OR APPROVED EQUAL) DUAL CHECK VALVE BACKFLOW WITH ATMOSPHERIC VENT CONFORMING TO ASSE 1022.
- 6 PROVIDE UNDERCOUNTER HUB DRAIN FOR DISCHARGE FROM ICE MAKER DRAIN. ICE MAKER DRAIN TO DISCHARGE VIA A 1" AIR GAP.
- 7 ALTERNATE P1: PROVIDE 1" NG FOR OUTDOOR NATURAL GAS GRILL. ROUTE 1" NG LINE DN TO ABOVE FLOOR & ROUTE THRU EXTERIOR WALL AT 12" ABOVE FINISHED GRADE. ONCE OUTSIDE ROUTE LINE UNDERGROUND TO LOCATION OF GRILL AND STUB UP WITH SHUT-OFF VALVE AND CAP FOR FUTURE EQUIPMENT CONNECTION.
- 8 1-1/4" NG DN IN WALL TO SERVE KITCHEN RANGE. CONNECT TO GAS SOLENOID VALVE PROVIDED WITH RANGE HOOD FOR AUTOMATIC SHUT-OFF.
- 9 CONNECT TO EXISTING PIPING AND XRAY SLAB IN AREA TO DETERMINE METHOD OF CONNECTION UNDER STRUCTURAL SLAB.



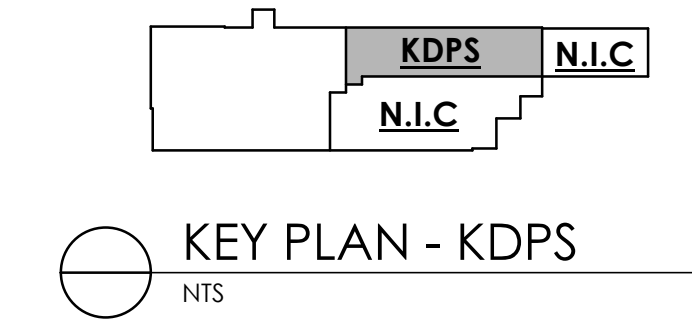
City of Kalamazoo - Crosstown Facility
 CPED & KDPS Workplace Renovation
 150 E Crosstown Parkway Kalamazoo MI 49001

NOT FOR
 REGULATORY
 APPROVAL,
 PERMITTING,
 OR
 CONSTRUCTION

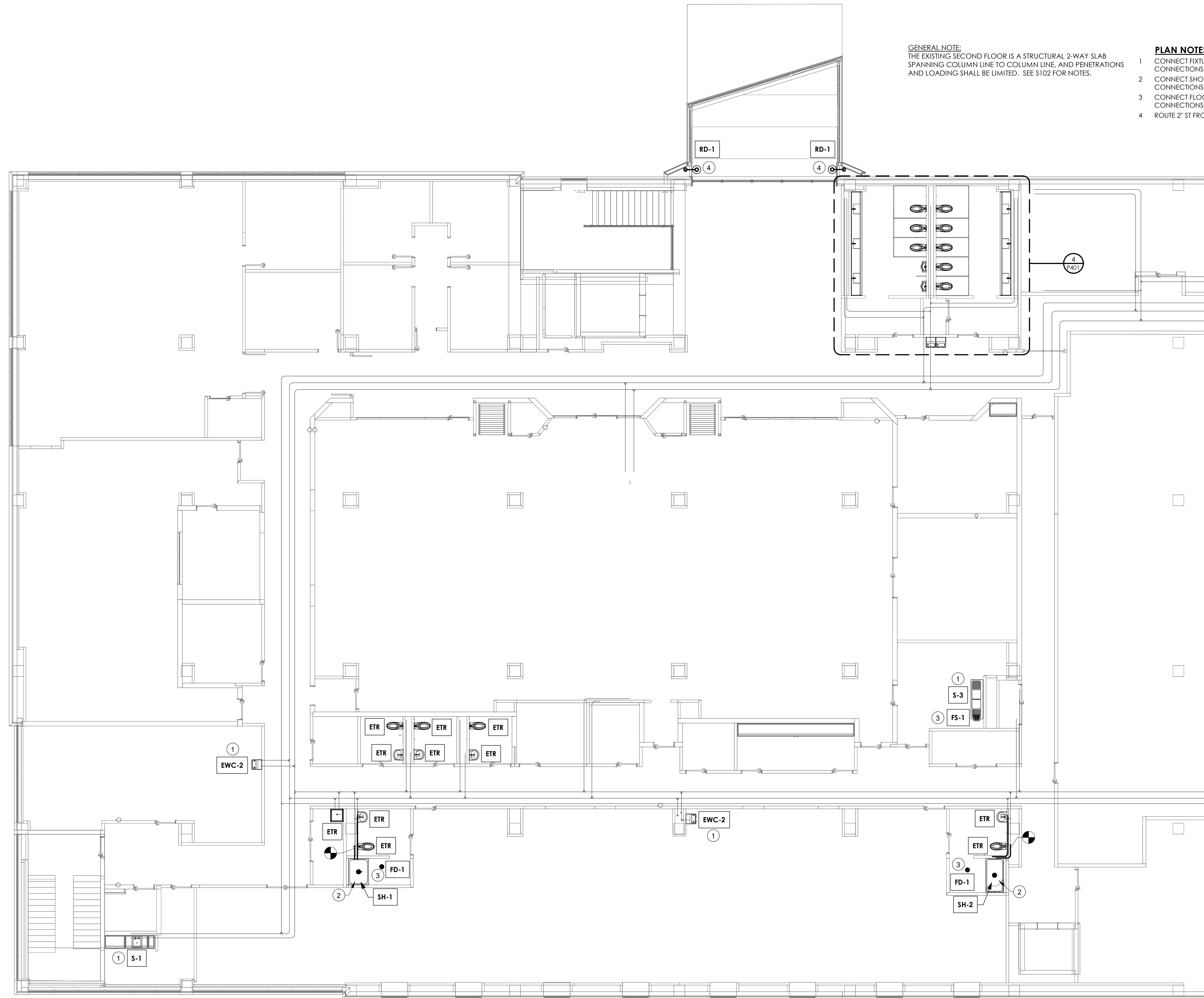
Bid 08/21/2025
 © 2025, intersect studio, llc
 Project Number: 23-046

**MAIN LEVEL KDPS
 PLUMBING PLAN**

1 MAIN LEVEL KDPS PLUMBING PLAN
 P101 1/8" = 1'-0"



P101



GENERAL NOTE:
 THE EXISTING SECOND FLOOR IS A STRUCTURAL 2-WAY SLAB SPANNING COLUMN LINE TO COLUMN LINE, AND PENETRATIONS AND LOADING SHALL BE LIMITED. SEE S102 FOR NOTES.

PLAN NOTES

- 1 CONNECT FIXTURE TO EXISTING TO REMAIN PIPING WITHIN WALL. FIELD VERIFY EXACT CONNECTIONS.
- 2 CONNECT SHOWER DRAIN TO EXISTING TO REMAIN SANITARY LINE. FIELD VERIFY EXACT CONNECTIONS.
- 3 CONNECT FLOOR DRAIN TO EXISTING TO REMAIN SANITARY LINE. FIELD VERIFY EXACT CONNECTIONS.
- 4 ROUTE 2" ST FROM ROOF DRAIN (RD-1) DN IN CHASE. REFER TO SHEET P100 FOR CONTINUATION.

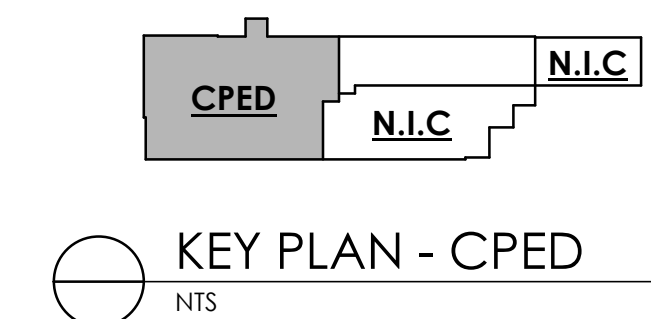
City of Kalamazoo - Crosstown Facility
 CPED & KDPS Workplace Renovation
 150 E Crosstown Parkway Kalamazoo MI 49001

NOT FOR
 REGULATORY
 APPROVAL,
 PERMITTING,
 OR
 CONSTRUCTION

Bid 08/21/2025
 © 2025, intersect studio, llc
 Project Number: 23-046

**UPPER LEVEL CPED
 PLUMBING PLAN**

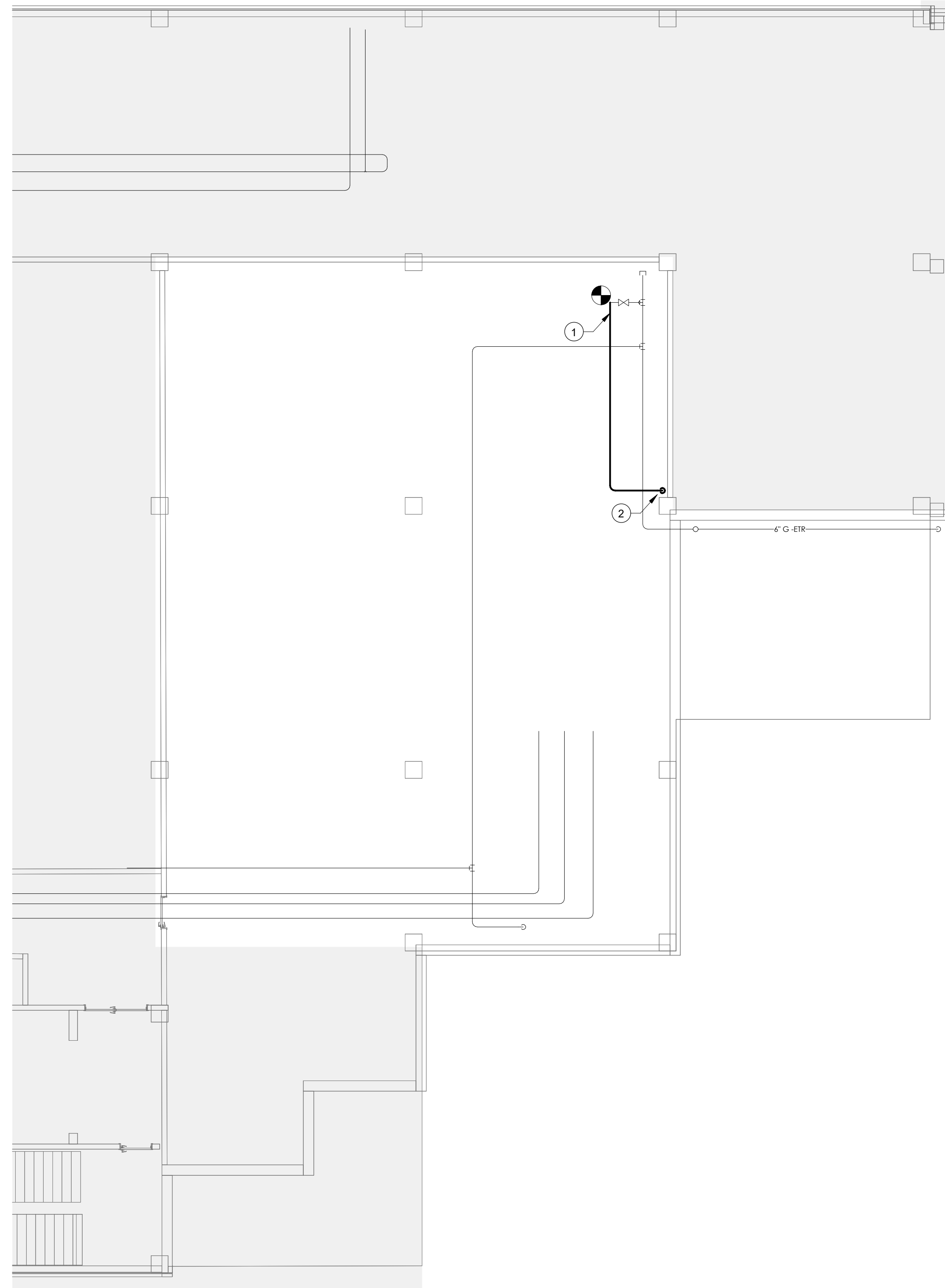
1 UPPER LEVEL CPED PLUMBING PLAN
 P102 1/8" = 1'-0"



P102

PLAN NOTES

- 1 CONNECT 1-1/2" NG TO EXISTING 1-1/2" VALVE AND CAPPED CONNECTION IN MECHANICAL ROOM AND ROUTE AS INDICATED. FIELD VERIFY EXACT CONNECTION.
- 2 1-1/2" NG DN THRU FLOOR. REFER TO SHEET P102 FOR CONTINUATION.

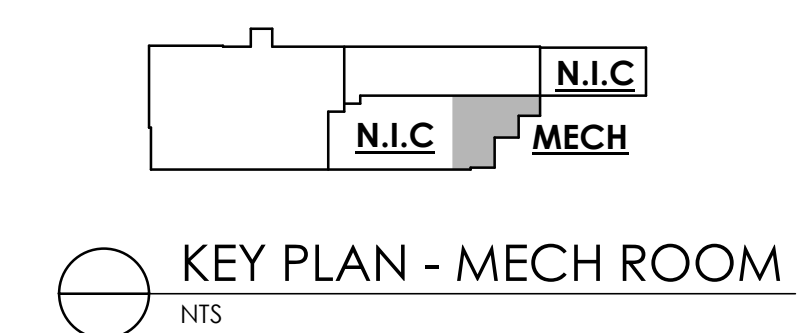


City of Kalamazoo - Crosstown Facility
 CPED & KDPS Workplace Renovation
 150 E Crosstown Parkway Kalamazoo MI 49001

NOT FOR
 REGULATORY
 APPROVAL,
 PERMITTING,
 OR
 CONSTRUCTION

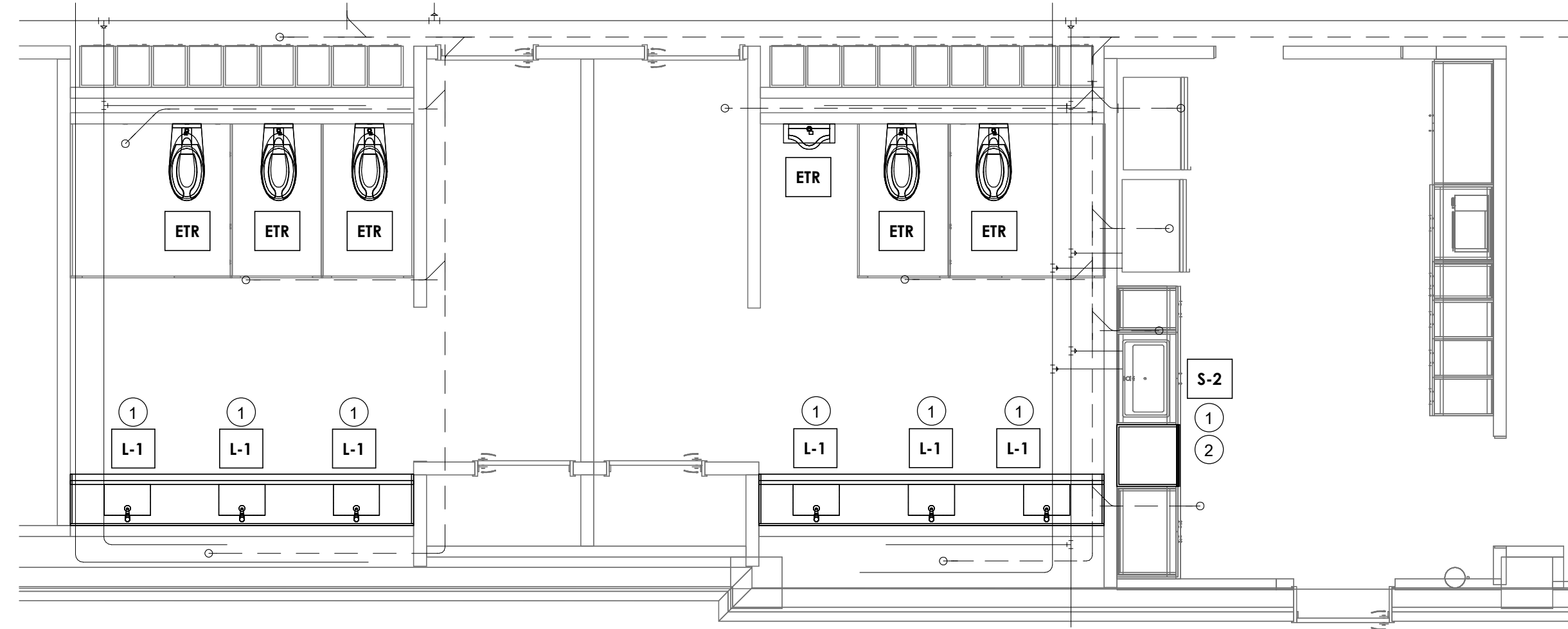
Bid 08/21/2025
 © 2025, intersect studio, llc
 Project Number: 23-046

1
 P103 UPPER LEVEL MECH ROOM PLUMBING PLAN
 1/8" = 1'-0"

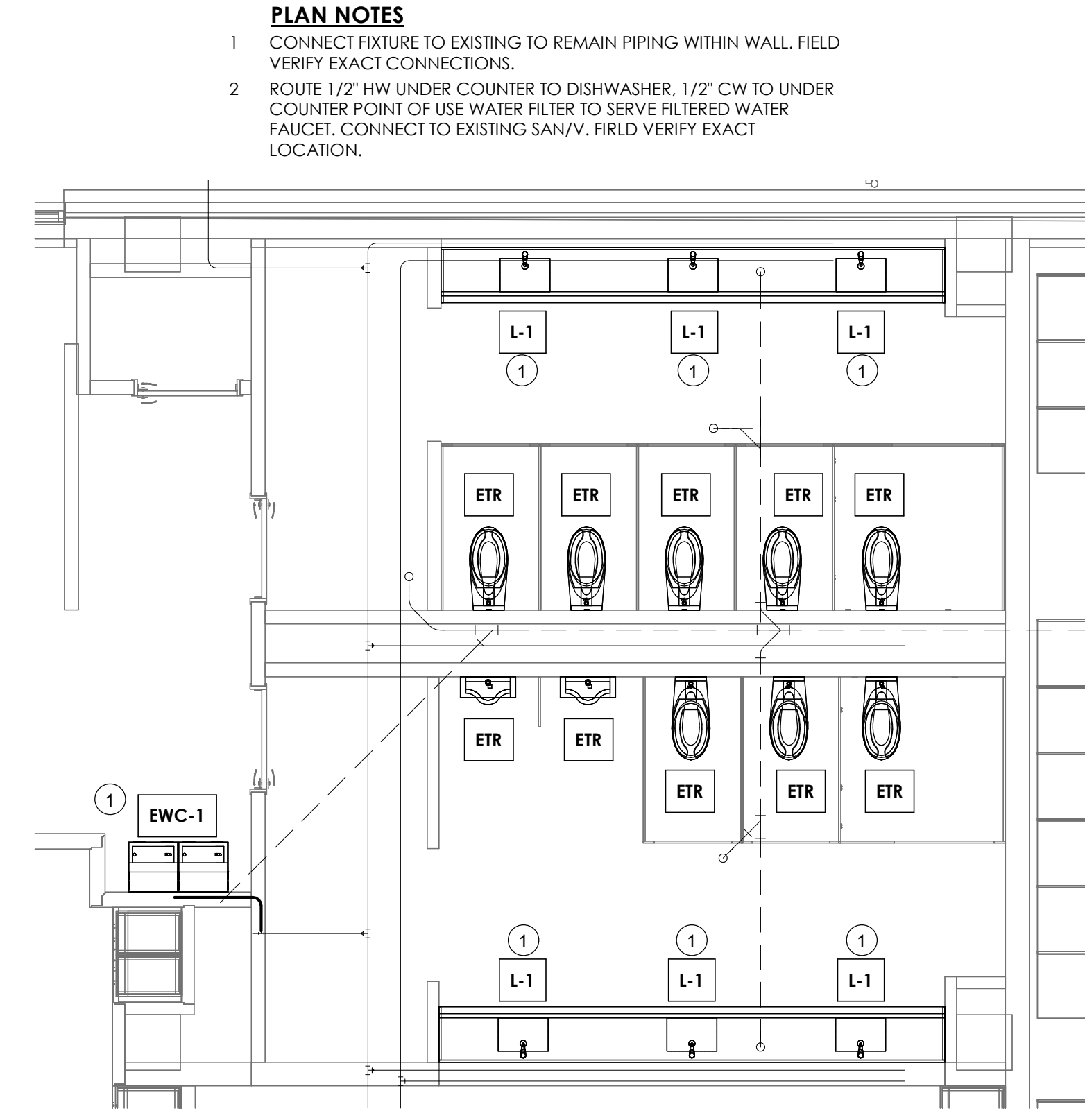


UPPER LEVEL MECH ROOM PLUMBING PLAN

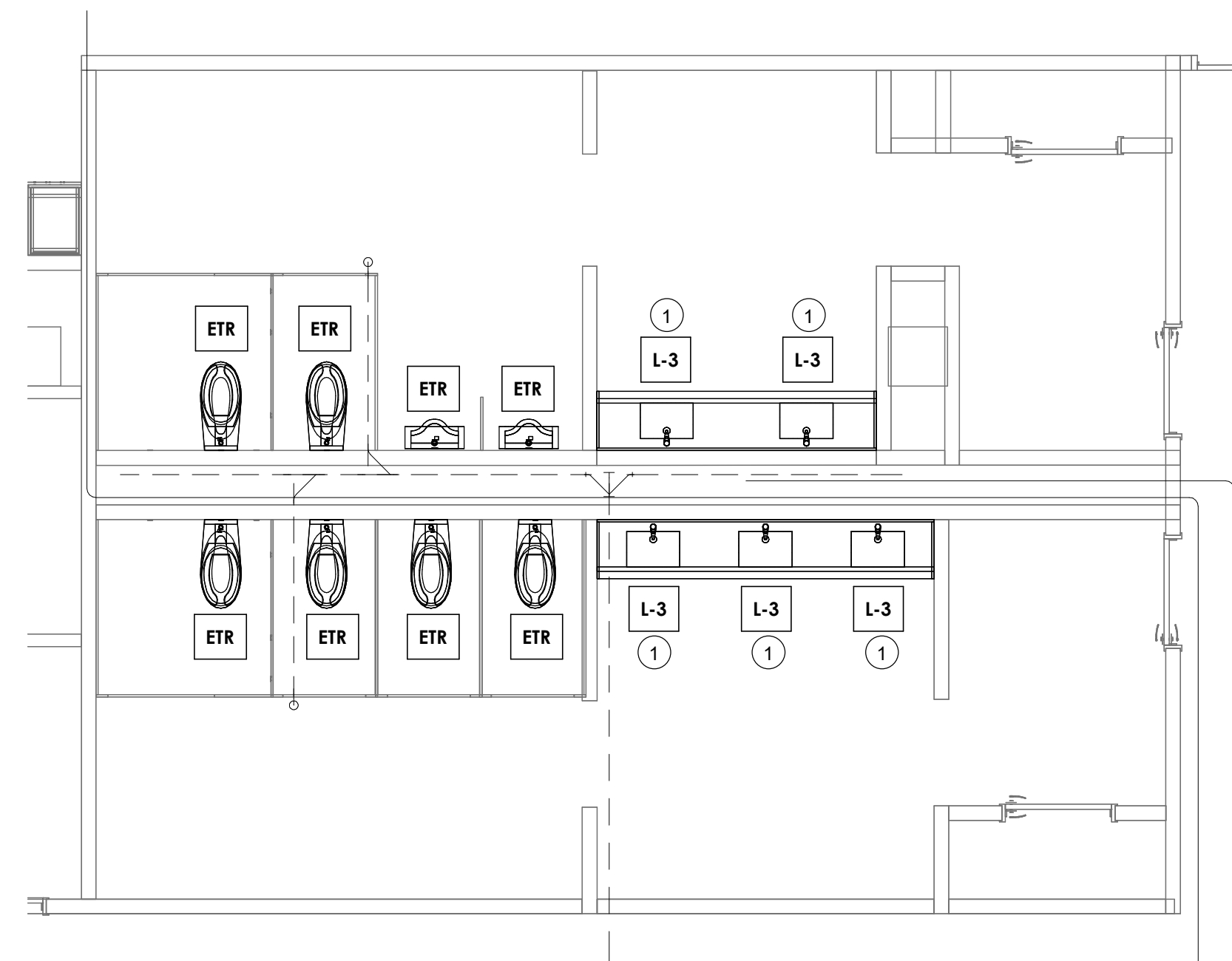
P103



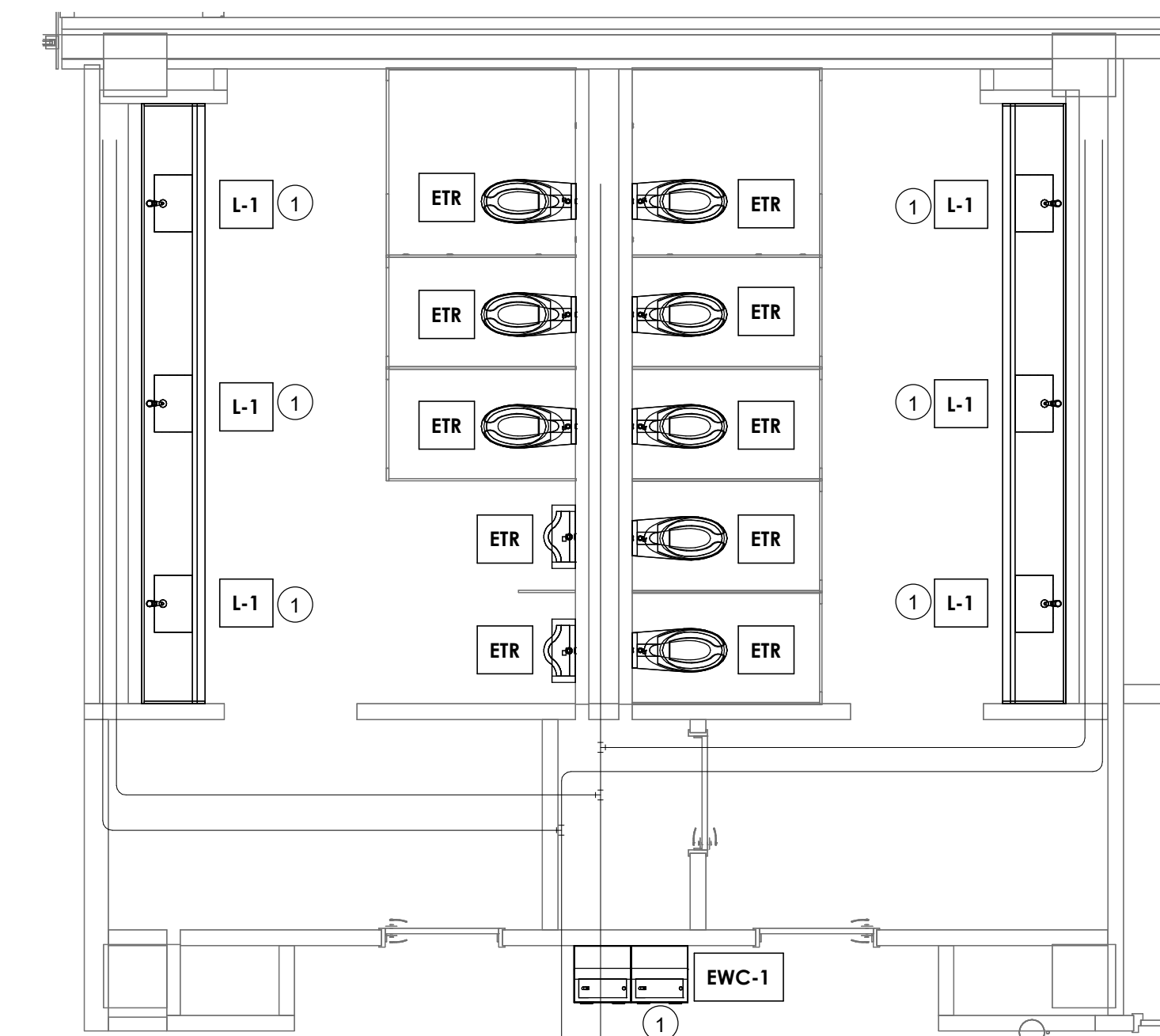
1 MAIN LEVEL CPED SOUTH RESTROOM
P401 1/4" = 1'-0"



2 MAIN LEVEL CPED NORTH RESTROOM
P401 1/4" = 1'-0"



3 MAIN LEVEL KDPS RESTROOM
P401 1/4" = 1'-0"



4 UPPER LEVEL CPED NORTH RESTROOM
P401 1/4" = 1'-0"

PLAN NOTES

- 1 CONNECT FIXTURE TO EXISTING TO REMAIN PIPING WITHIN WALL. FIELD VERIFY EXACT CONNECTIONS.
- 2 ROUTE 1/2" HW UNDER COUNTER TO DISHWASHER. 1/2" CW TO UNDER COUNTER POINT OF USE WATER FILTER TO SERVE FILTERED WATER FAUCET. CONNECT TO EXISTING SAN/V. FIELD VERIFY EXACT LOCATION.

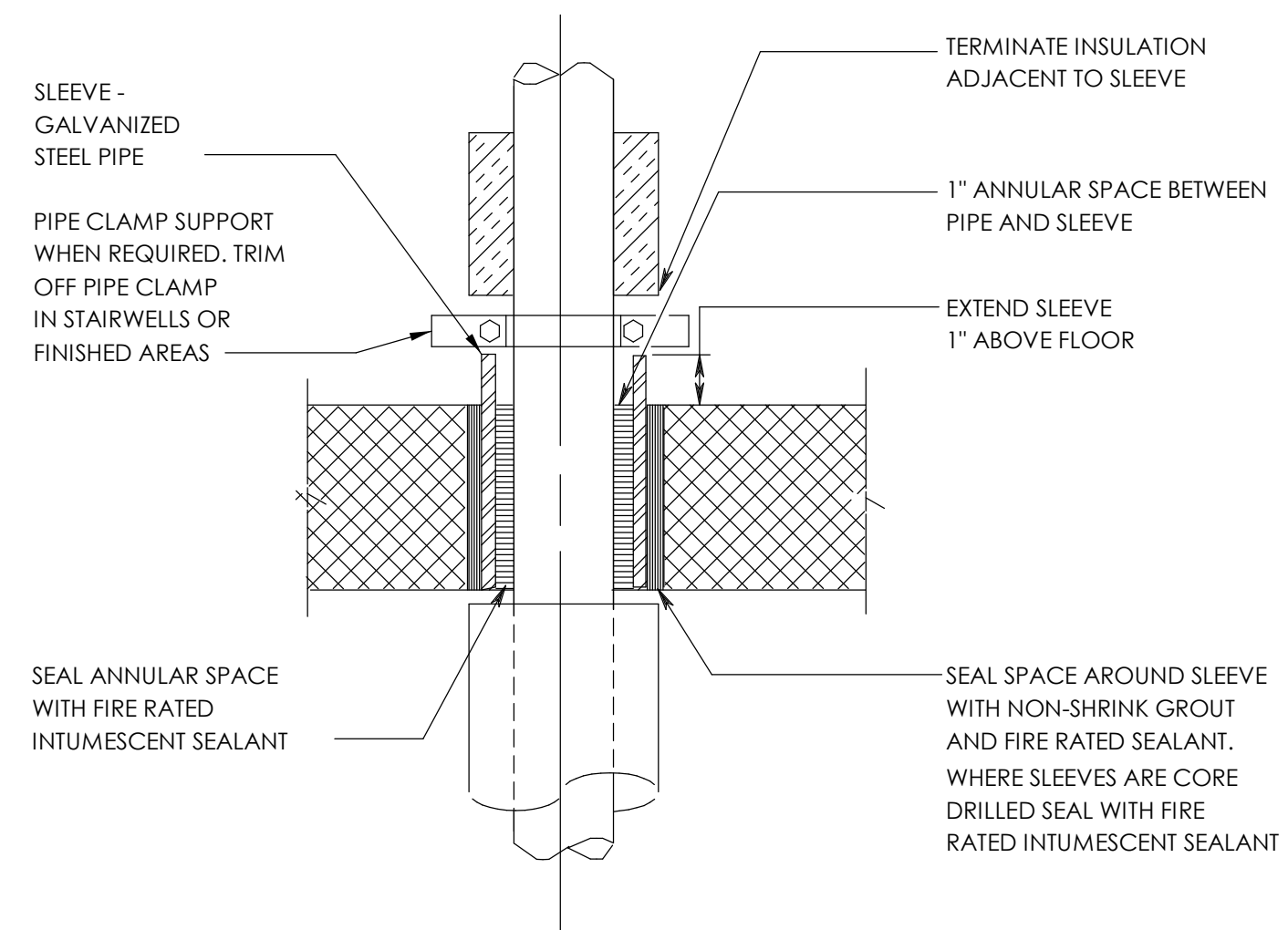
City of Kalamazoo - Crosstown Facility
CPED & KDPS Workplace Renovation
150 E Crosstown Parkway Kalamazoo MI 49001

NOT FOR
REGULATORY
APPROVAL,
PERMITTING,
OR
CONSTRUCTION

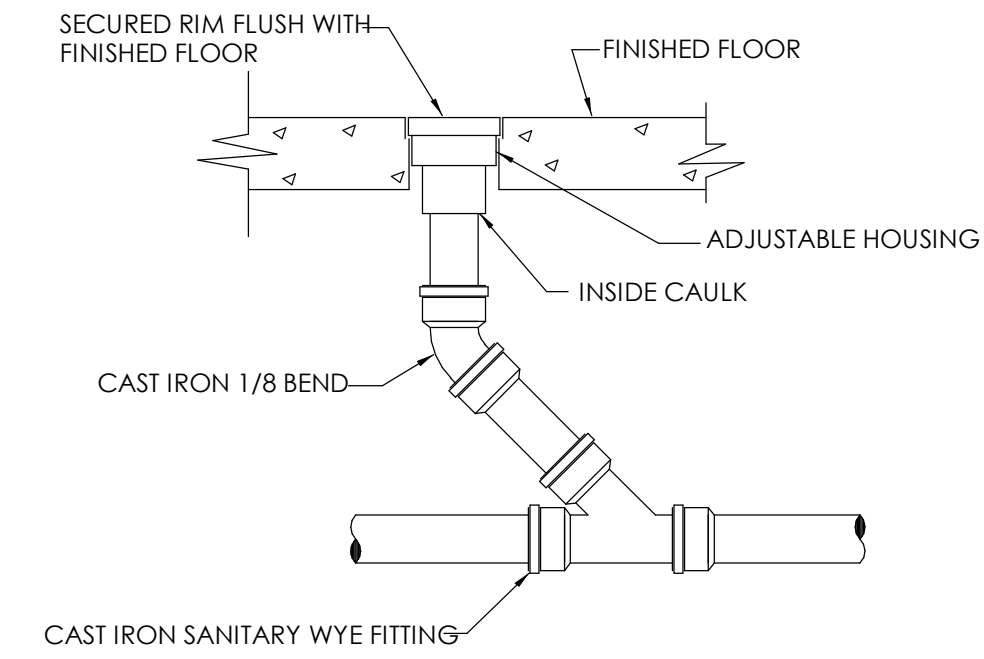
Bid 08/21/2025
© 2025, intersect studio, llc
Project Number: 23-046

ENLARGED
PLUMBING PLAN

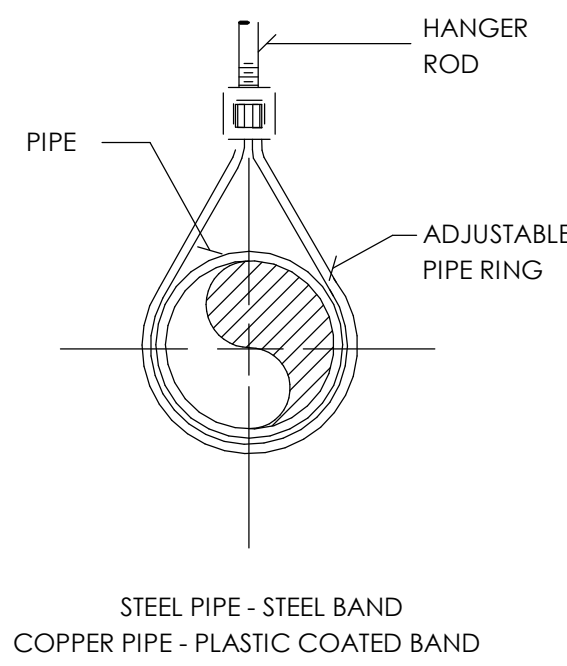
P401



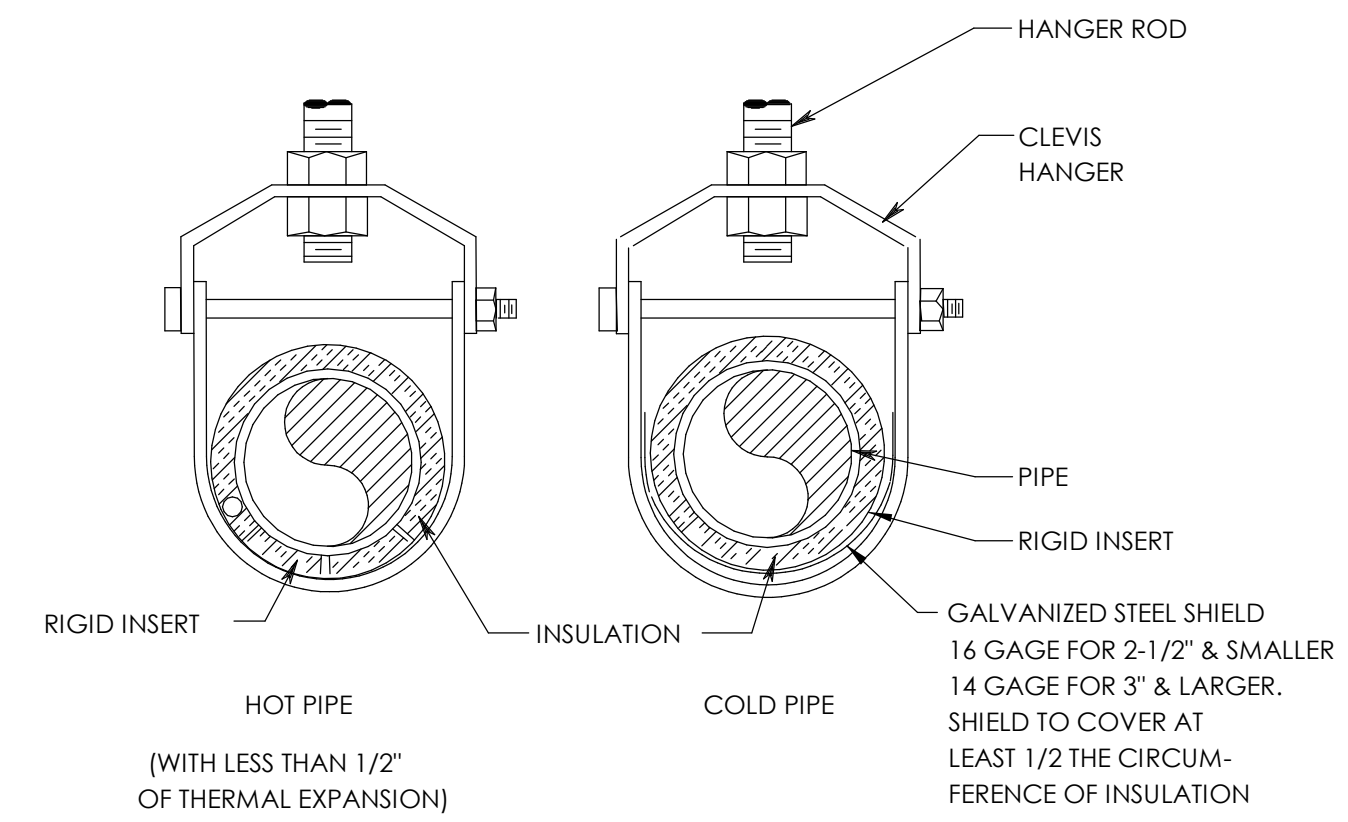
3
P501 PIPE FLOOR SLEEVE DETAIL
NOT TO SCALE



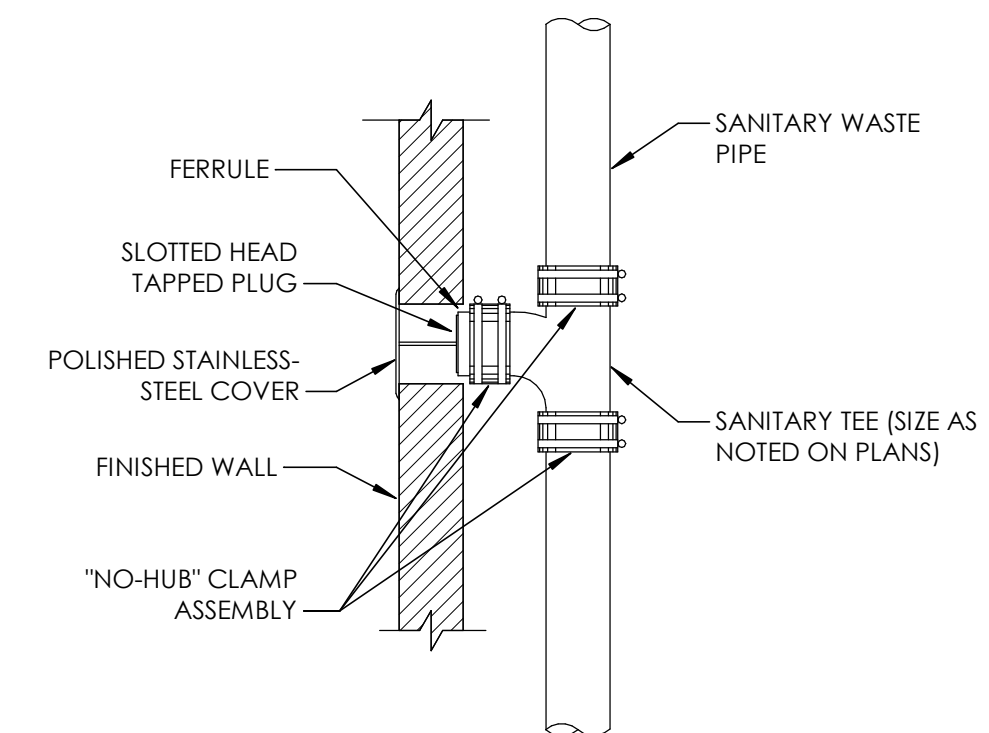
1
P501 FLOOR CLEANOUT DETAIL
NOT TO SCALE



4
P501 UNINSULATED PIPE HANGER DETAIL
NOT TO SCALE



2
P501 INSULATED PIPE HANGER DETAIL
NOT TO SCALE



5
P501 WALL CLEANOUT DETAIL
1/8\"/>

City of Kalamazoo - Crosstown Facility
CPED & KDPS Workplace Renovation
150 E Crosstown Parkway Kalamazoo MI 49001

NOT FOR
Seal:
REGULATORY
APPROVAL,
PERMITTING,
OR
CONSTRUCTION

Bid 08/21/2025
© 2025, intersect studio, llc
Project Number: 23-046

PLUMBING DETAILS

P501

PLUMBING SPECIALTIES SCHEDULE							
MARK	FIXTURE	STORM	SAN	VENT	CW	HW	DESCRIPTION
FD-1	FLOOR DRAIN	--	SEE PLANS	--	--	--	FIXTURE: ZURN MODEL Z4158 FLOOR & SHOWER DRAIN. CAST IRON BODY. BOTTOM OUTLET TYPE B POLISHED NICKEL BRONZE LIGHT DUTY STRAINER. ACCESSORIES: PROVIDE WITH ZURN Z1072 BARRIER TRAP SEAL.
RD-1	ROOF DRAIN	SEE PLANS	--	--	--	--	FIXTURE: ZURN MODEL Z164 COMBINATION ROOF & OVERFLOW DRAIN WITH LOW SILHOUETTE DOMES. CAST IRON BODIES W/ NO HUB OUTLET. 4-1/4" DOME. MEMBRANE FLASHING CLAMP / GRAVEL GUARDS.
	POINT OF USE THERMOSTATIC MIXING VALVE	--	--	--	1/2"	1/2"	WATER TEMPERATURE REGULATING VALVE. LEAD FREE BRONZE BODY, THREADED CONNECTIONS. LOW TEMPERATURE, DUAL ACTION. INTERCHANGEABLE THERMOSTAT. INTEGRAL FILTER WASHERS AND CHECK VALVES. ASSE 1070 LISTED, ADJUSTABLE FROM 80F TO 120F WITH LOCKING FEATURE. SET OUTLET TEMPERATURE AT 110F. MAXIMUM PRESSURE 150PSI. WATTS SERIES LFUSG-B OR EQUAL.
	CALIBRATED BALANCING VALVES						2 INCHES AND SMALLER. WORKING PRESSURE: 125PSIG. MAXIMUM OPERATING TEMPERATURE 250F. BRONZE BODY. BRASS BALL CONSTRUCTION WITH CALIBRATED ORFICE. THREADED END CONNECTIONS
	WATER HAMMER ARRESTORS						PERMANENTLY SEALED BELLOW OR EXPANDING CHAMBER TYPE DEVICE FOR CONTROL OF WATER HAMMER P.D.I. APPROVED. SMITH HYDROTROL OR SIMILAR BY JOSAM, MIFAB, WADE, OR ZURN.
	TEMPERATURE AND PRESSURE RELIEF VALVE						ANSI Z21.22 CERTIFIED, BRONZE BODY, TEFLON SEAT, STAINLESS STEEL STEM AND SPRINGS, AUTOMATIC DIRECT PRESSURE ACTUATED. TEMPERATURE RELIEF MAXIMUM 210 DEGREES F. CAPACITY ASME CERTIFIED AND LABELED, WATTS SERIES 40, 140, 240
	BEVERAGE DISPENSER PREVENTOR						ASSE 1020 CERTIFIED, DUAL CHECK VALVE WITH ATMOSPHERIC PORT. WATTS SERIES SD-3 OR APPROVED EQUAL.

DEMOLITION GENERAL NOTES	
1.	REFER TO ARCHITECTURAL DEMOLITION PLAN FOR EXACT LOCATIONS OF PLUMBING FIXTURES TO BE REMOVED.
2.	IN THE INSTALLATION OR REMOVAL OF ANY PART OF A DRAINAGE SYSTEM, DEAD ENDS SHALL BE PROHIBITED. CLEANOUT EXTENSIONS AND APPROVED FUTURE FIXTURE DRAINAGE PIPING SHALL NOT BE CONSIDERED AS DEAD ENDS PER OHIO PLUMBING CODE SECTION 704.5.
3.	PRIOR TO SUBMITTING BID, CONTRACTOR SHALL VISIT JOB SITE TO MEET WITH PROJECT MANAGER AND BECOME FAMILIAR WITH EXISTING CONDITIONS WHICH WILL AFFECT THE EXECUTION OF WORK. NO ADDITIONAL COMPENSATION WILL BE ALLOWED FOR FAILURE TO OBTAIN THIS INFORMATION.
4.	ALL ITEMS OF DEMOLITION SHALL BE THE RESPONSIBILITY OF THE CONTRACTOR TO REMOVE FROM THE JOB SITE AFTER GIVING THE OWNER FIRST RIGHT TO SALVAGE ANY AND ALL MATERIALS.
5.	ITEMS TO BE REMOVED SHALL INCLUDE FIXTURES & ALL INCIDENTAL PIPING, FITTINGS AND ACCESSORIES AS INDICATED ON PLANS.
6.	WHERE EXISTING EQUIPMENT AND/OR FIXTURES ARE REMOVED THE ASSOCIATED SANITARY WASTE/VENT AND/OR WATER SUPPLY BRANCH SHALL BE REMOVED BACK TO THE MAIN WHERE POSSIBLE AND CAPPED OR PLUGGED AS REQUIRED.
7.	DISCONNECT ALL SUPPLY AND WASTE PIPING FROM FIXTURES AND EQUIPMENT TO BE REMOVED BY OTHER TRADES.
8.	ALL SECTIONS OF SUPPLY AND/OR WASTE PIPING THAT IS DISCONNECTED BUT NOT TOTALLY REMOVED SHALL BE CAPPED OR PLUGGED WELL BELOW/BEHIND FINISHED SURFACES.
9.	WHERE EXISTING WALLS ARE DEMOLISHED, ANY PLUMBING PIPING CONTAINED THEREIN THAT IS NOT DESIGNATED TO BE REMOVED SHALL BE OFF-SET, RELOCATED OR RETAINED IN PLACE AS MAY BE REQUIRED FOR PROPER OPERATION OF OVERALL SYSTEM. THIS REQUIREMENT APPLIES TO ANY SITUATION THAT MAY BE ENCOUNTERED DURING CONSTRUCTION OF DEMOLITION, EVEN THOUGH IT MAY NOT BE SHOWN ON THE DRAWINGS.
10.	WHERE EXISTING PLUMBING FIXTURES ARE TO BE REMOVED ALL EXISTING WALLS/ROOFS SHALL BE PATCHED THAT ARE AFFECTED. P.C. SHALL FINISH WALLS/ROOF PER ARCHITECT'S DIRECTION. P.C. SHALL COORDINATE EXACT WALL FINISH WITH ARCHITECT. NO ADDITIONAL COMPENSATION WILL BE ALLOWED FOR FAILURE TO OBTAIN THIS INFORMATION.

REMARKS:	
1.	ALL FIXTURES AS NOTED TO MEET ALL REQUIRED ADA/CODE COMPLIANCE STANDARDS IN ACCESSIBLE STALLS.
2.	FOR EXACT LOCATIONS OF PLUMBING FIXTURES REFER TO ARCHITECTURAL DRAWINGS.
3.	MAXIMUM FLOW RATES FOR PUBLIC LAVATORY FAUCETS SHALL BE 0.5 GPM.
4.	ALL PLUMBING FIXTURES & FAUCETS SHALL BE CONTINGENT UPON BUILDING OWNER APPROVAL PRIOR TO INSTALLATION.
5.	ADA COMPLIANT LAVATORIES WILL BE MOUNTED AT A MAXIMUM OF 34" AFF.
6.	ALL LAVATORIES HAVING EXPOSED PIPING SHALL HAVE PIPE INSULATION TO PREVENT AGAINST CONTACT. THERE WILL BE NO SHARP OR ABRASIVE SURFACES UNDER LAVATORIES.

PLUMBING FIXTURE SCHEDULE						
MARK	FIXTURE	SAN	VENT	CW	HW	DESCRIPTION
L-1	LAVATORY (UNDERMOUNT)	1-1/2"	1-1/2"	1/2"	1/2"	FIXTURE: AMERICAN STANDARD STUDIO RECTANGULAR UNDERMOUNT LAVATORY MODEL 0614.000. VITREOUS CHINA. COLOR TO BE WHITE. FAUCET: ZURN DECK MTD SENSOR OPERATED FAUCET MODEL Z6913-XL. POLISHED CHROME FINISH, WITH THERMOSTATIC MIXING VALVE. HYDRO-POWERED BATTERY OPTION, 0.5 GPM. SUPPLIES: CHROME PLATED RIGID OR FLEXIBLE SUPPLIES, REDUCERS, & ESCHUTEONS, WHERE EXPOSED INSULATE FOR ADA COMPLIANCE. DRAIN: STANDARD 1-1/4" GRID DRAIN, CHROME FINISH. TRAP: CHROME PLATED CAST BRASS ADJUSTABLE 1-1/4" "P" TRAP WITHOUT CLEANOUT, WASTE TO WALL ESCUTCHEON, WHERE EXPOSED INSULATE FOR ADA COMPLIANCE.
L-2	LAVATORY (WALL MOUNT)	1-1/2"	1-1/2"	1/2"	1/2"	FIXTURE: AMERICAN STANDARD DECORUM WALL MOUNT LAVATORY MODEL 9024.901EC. VITREOUS CHINA. SINGLE CENTER HOLE. NO OVERFLOW. COLOR TO BE WHITE. FAUCET: ZURN DECK MTD SENSOR OPERATED FAUCET MODEL Z6913-XL. POLISHED CHROME FINISH, WITH THERMOSTATIC MIXING VALVE. HYDRO-POWERED BATTERY OPTION, 0.5 GPM. SUPPLIES: CHROME PLATED RIGID OR FLEXIBLE SUPPLIES, REDUCERS, & ESCHUTEONS, WHERE EXPOSED INSULATE FOR ADA COMPLIANCE. DRAIN: STANDARD 1-1/4" GRID DRAIN, CHROME FINISH. TRAP: CHROME PLATED CAST BRASS ADJUSTABLE 1-1/4" "P" TRAP WITHOUT CLEANOUT, WASTE TO WALL ESCUTCHEON, WHERE EXPOSED INSULATE FOR ADA COMPLIANCE.
L-3	LAVATORY (UNDERMOUNT)	1-1/2"	1-1/2"	1/2"	1/2"	FIXTURE: AMERICAN STANDARD STUDIO RECTANGULAR UNDERMOUNT LAVATORY MODEL 0614.000. VITREOUS CHINA. COLOR TO BE WHITE. FAUCET: ZURN SINGLE-CONTROL DECK MOUNT MANUAL OPERATED FAUCET MODEL Z831R1-XL. CHROME-PLATED CAST BRASS BODY WITH STAINLESS STEEL FLEX CONNECTION HOSES. SUPPLIES: CHROME PLATED RIGID OR FLEXIBLE SUPPLIES, REDUCERS, & ESCHUTEONS, WHERE EXPOSED INSULATE FOR ADA COMPLIANCE. DRAIN: STANDARD 1-1/4" GRID DRAIN, CHROME FINISH. TRAP: CHROME PLATED CAST BRASS ADJUSTABLE 1-1/4" "P" TRAP WITHOUT CLEANOUT, WASTE TO WALL ESCUTCHEON, WHERE EXPOSED INSULATE FOR ADA COMPLIANCE.
S-1	SINK (SINGLE BOWL UNDERMOUNT)	1-1/2"	1-1/2"	1/2"	1/2"	FIXTURE: ELKAY LUSTERTONE CLASSIC STAINLESS STEEL SINK MODEL ELUH281610. SINGLE BOWL 30-1/2" X 18-1/2" X 10" UNDERMOUNT ADA SINK. TWO HOLES 4" ON CENTER. FAUCET: DELTA SINGLE HANDLE DECK MOUNT WITH TWO FUNCTION PULL-DOWN SPRAYER MODEL 9159-LS-DST, 1.8 GPM, ADA COMPLIANT. SUPPLIES: CHROME PLATED RIGID OR FLEXIBLE SUPPLIES, REDUCERS, & ESCHUTEONS, WHERE EXPOSED INSULATE FOR ADA COMPLIANCE. DRAIN: STANDARD 1-1/4" GRID STRAINER DRAIN, CHROME FINISH. TRAP: CHROME PLATED CAST BRASS ADJUSTABLE 1-1/4" "P" TRAP WITHOUT CLEANOUT, WASTE TO WALL ESCUTCHEON, WHERE EXPOSED INSULATE FOR ADA COMPLIANCE.
S-2	SINK (DOUBLE BOWL UNDERMOUNT)	1-1/2"	1-1/2"	1/2"	1/2"	FIXTURE: ELKAY LUSTERTONE CLASSIC DOUBLE BOWL UNDERMOUNT ADA SINK MODEL ELUHAD312045RPD, STAINLESS STEEL. FAUCET: DELTA SINGLE HANDLE DECK MOUNT WITH TWO FUNCTION PULL-DOWN SPRAYER MODEL 9159-LS-DST, 1.8 GPM, ADA COMPLIANT. PROVIDE WITH ADDITIONAL FILTERED WATER DISPENSER FAUCET, SINGLE HANDLE DECK MOUNTED, 1.5 GPM, DELTA MODEL 1930-DST. SUPPLIES: CHROME PLATED RIGID OR FLEXIBLE SUPPLIES, REDUCERS, & ESCHUTEONS, WHERE EXPOSED INSULATE FOR ADA COMPLIANCE. DRAIN: STANDARD 1-1/4" GRID STRAINER DRAIN, CHROME FINISH. TRAP: CHROME PLATED CAST BRASS ADJUSTABLE 1-1/4" "P" TRAP WITHOUT CLEANOUT, WASTE TO WALL ESCUTCHEON, WHERE EXPOSED INSULATE FOR ADA COMPLIANCE. ACCESSORIES: INSINKERATOR EVOLUTION COMPACT GARBAGE DISPOSAL, 3/4 HP, SINGLE PHASE, HARDWIRED, WITH DISHWASHER CONNECTION.
S-3	SINK (TWO COMP SINK W/ LR DRAINBOARDS)	1-1/2"	1-1/2"	1/2"	1/2"	FIXTURE: ELKAY DEPENDABIL STAINLESS STEEL TWO COMP SINK W/ LR DRAIN BOARDS MODEL 14-2C16X20-2-18X. FAUCET: 8" CENTERSET WALL MOUNT FAUCET FLEXIBLE HOSE W/ SPRAY HEAD + ARC TUBE SPOUT MODEL LK943AF12LC. CHROME-PLATED BRASS W/ QUARTER TURN CERAMIC DISC VALVE. SUPPLIES: CHROME PLATED RIGID OR FLEXIBLE SUPPLIES, REDUCERS, & ESCHUTEONS, WHERE EXPOSED INSULATE FOR ADA COMPLIANCE. DRAIN: ELKAY LK35 3-1/2" BASKET STRAINER - CHROME TRAP: CHROME PLATED CAST BRASS ADJUSTABLE 3-1/2" "P" TRAP WITHOUT CLEANOUT, WASTE TO WALL ESCUTCHEON, WHERE EXPOSED INSULATE FOR ADA COMPLIANCE.
S-4	SINK (SINGLE BOWL UNDERMOUNT)	1-1/2"	1-1/2"	1/2"	1/2"	FIXTURE: ELKAY LUSTERTONE CLASSIC STAINLESS STEEL SINK MODEL ELUH281610. SINGLE BOWL 30-1/2" X 18-1/2" X 10" UNDERMOUNT ADA SINK. TWO HOLES 4" ON CENTER. FAUCET: DELTA SINGLE HANDLE DECK MOUNT WITH TWO FUNCTION PULL-DOWN SPRAYER MODEL 9159-LS-DST, 1.8 GPM, ADA COMPLIANT. SUPPLIES: CHROME PLATED RIGID OR FLEXIBLE SUPPLIES, REDUCERS, & ESCHUTEONS, WHERE EXPOSED INSULATE FOR ADA COMPLIANCE. DRAIN: STANDARD 1-1/4" GRID STRAINER DRAIN, CHROME FINISH. TRAP: CHROME PLATED CAST BRASS ADJUSTABLE 1-1/4" "P" TRAP WITHOUT CLEANOUT, WASTE TO WALL ESCUTCHEON, WHERE EXPOSED INSULATE FOR ADA COMPLIANCE.
SH-1	FOUR-PIECE SHOWER	3"	1-1/2"	1/2"	1/2"	FIXTURE: AKER FOUR PIECE SHOWER W/ LARGE TOP CORNER SHELVES, WIDE SOAP DISH AND STANDARD ACRYLIC HANDLE. ACCESSORIES: MOEN M-DURA SINGLE FUNCTION SHOWERHEAD MODEL 9263, CHROME FINISH. MOEN M-DURA SINGLE HANDLE POSI-TEMP TRIM MODEL T9370, CHROME FINISH, WITH BRASS POSI-TEMP ROUGH-IN MIXING VALVE WITH INTEGRAL STOPS (MODEL TO MATCH PIPE CONNECTIONS).
SH-2	ONE PIECE ROLL IN SHOWER (ADA)	3"	1-1/2"	1/2"	1/2"	FIXTURE: AKER 1 PIECE ROLL IN SHOWER W/ L-SHAPED FOLD-UP PHENOLIC WHITE SEAT, CHROME PRESSURE BALANCE MIXING VALVE W/ HAND-HELD SHOWER, ADA/ANSI COMPLIANT. ACCESSORIES: MOEN THREE-FUNCTION COMMERCIAL SHOWER SYSTEM, 8342, 8342EP15
EW-1	DOUBLE ELECTRIC WATER COOLER W/ BOTTLE FILLER	2"	1-1/2"	1/2"	--	FIXTURE: ELKAY BI-LEVEL ADA ELECTRIC WATER COOLER WITH BOTTLE FILLER MODEL EZSTL8WSLK, LIGHT GRAY GRANITE FINISH, WALL MOUNT, REFER TO ARCHITECTURAL PLANS FOR MOUNTING HEIGHT.
EW-2	SINGLE ELECTRIC WATER COOLER W/ BOTTLE FILLER	2"	1-1/2"	1/2"	--	FIXTURE: ELKAY SINGLE ADA ELECTRIC WATER COOLER WITH BOTTLE FILLER MODEL LZS8WSLK, LIGHT GRAY GRANITE FINISH, WALL MOUNT, REFER TO ARCHITECTURAL PLANS FOR MOUNTING HEIGHT.
EW-3	RETROFIT BOTTLE FILLING STATION KIT	2"	1-1/2"	1/2"	--	FIXTURE: ELKAY RETROFIT BOTTLE FILLING STATION MODEL EZWSRK, NON-FILTERED, NON-REFRIGERATED HANDS FREE LAMINAR FLOW, REAL DRAIN, REFER TO ARCHITECTURAL PLAN FOR MOUNTING LOCATION.

City of Kalamazoo - Crosstown Facility
CPED & KDPS Workplace Renovation
150 E Crosstown Parkway Kalamazoo MI 49001

NOT FOR
Seal:
REGULATORY
APPROVAL,
PERMITTING,
OR
CONSTRUCTION

Bid 08/21/2025
 © 2025, intersect studio, llc
 Project Number: 23-046

PLUMBING SCHEDULES

P601

CITY OF KALAMAZOO - CROSSTOWN FACILITY

**150 E CROSSTOWN PARKWAY
SECTION 22, T.02S, R.11W
CITY OF KALAMAZOO
KALAMAZOO COUNTY, MI**

**SITE DEVELOPMENT PLANS
SEPTEMBER 08, 2025**

ISSUED FOR: BIDS/SITE PLAN SUBMITTAL

SHEET INDEX

No.	SHEET TITLE
T1.0	TITLE SHEET
C1.0	EXISTING CONDITIONS
C1.1	DEMOLITION PLAN
C2.0	SITE LAYOUT PLAN
C3.0	DETAILS
C3.1	FENCING DETAILS
.	.
.	.
.	.
.	.
.	.
.	.

OWNERS:

CITY OF KALAMAZOO
PUBLIC SAFETY BUILDING AUTHORITY
241 W SOUTH ST
KALAMAZOO, MI 49007
(269) 337-8243

ARCHITECT:

INTERSECT STUDIO
155 W MICHIGAN AVE, SUITE 1508
KALAMAZOO, MI 49007
TEL. (269) 775-1114

REVISIONS

No.	ISSUED FOR:	DATE:	BY:
0	CHECKLIST MEETING SUBMITTAL	07/31/2025	tc
1	BIDS/SITE PLAN SUBMITTAL	09/08/2025	tc
2	.	.	.
3	.	.	.
4	.	.	.
5	.	.	.

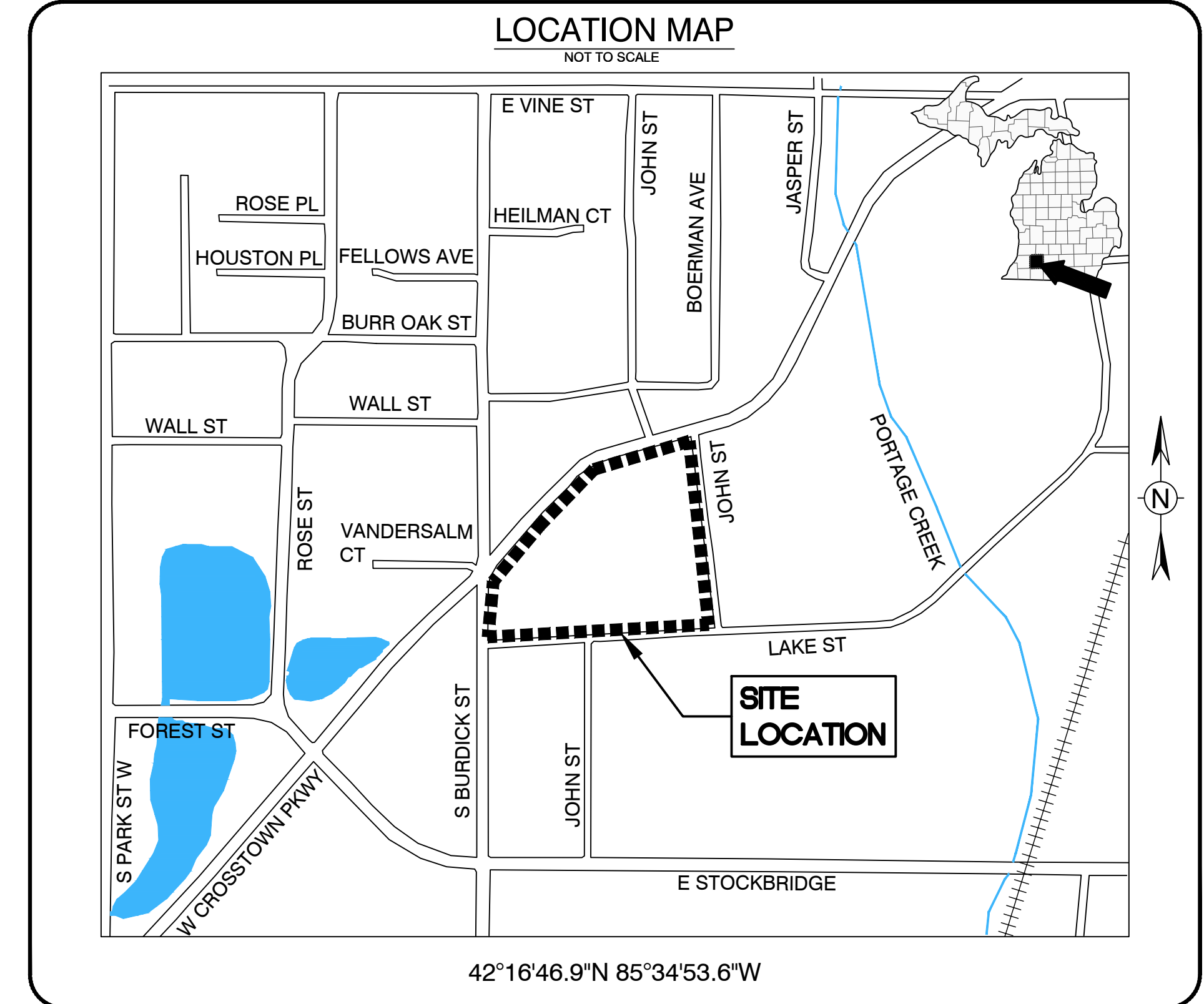
CIVIL ENGINEER:

AR ENGINEERING, LLC.
5725 VENTURE PARK DRIVE, SUITE A
KALAMAZOO, MI 49008
TEL. (269) 250-5991 FAX. (866) 569-0604



ANDREW WOLOSZYK, P.E.

DATE



LEGAL DESCRIPTION

PARCEL #: 06-22-332-001

7000 SECT 22 T2S R11W COM AT INTERSECTION OF E LI OF SOUTH BURDICK STREET AND N LI OF LAKE STREET, TH N 86DEG 43MIN E ALG SD N LI 667.08FT TO WLY LI OF EASEMENT FOR STREET (LIBER 719, PAGE 403), TH N 1DEG 32MIN 48SEC W ALG SD LI 39.67FT, TH CONT ALG SD LI N 5DEG 9MIN W 249.68FT, TH CONT ALG SD LI N 8DEG 46MIN W 221.06FT, TH CONT ALG SD LI N 12DEG 21MIN 41SEC W 38.75FT TO A PT ON A LI 42FT SLY OF AND PAR WITH TH CTR LI OF CROSSTOWN PARKWAY SD PT BEING 25FT WLY OF THE EASTERN TERMINUS OF SD LI, TH S 75DEG 9MIN W 238.14FT, TH ON A CURVE TO LEFT 169.04FT (R = 289.564FT, CHORD = S 58DEG 22MIN W 167.23FT), TH S 41DEG 35MIN W 343.19FT, TO E LI OF SOUTH BURDICK STREET, TH S ALG SD E LI TO P.O.B. EXC THE W 10FT AND THE S 10FT CONVEYED TO THE CITY OF KALAMAZOO IN LIBER 690 PAGE 329. PARCEL CONTAINS APP. 6.01 ACRES.

SITE DATA

- PROPERTY INFORMATION:
PARCEL ID #: 06-22-332-001
SITE AREA: 261,909 SF (6.01 AC)
- ZONING:
PROPERTY CURRENTLY ZONED:
LW2 - LIVE-WORK 2 DISTRICT
ABUTTING PROPERTY CURRENTLY ZONED:
NORTH: LW1 - LIVE-WORK 1 DISTRICT
SOUTH: RM15 - RESIDENTIAL, MULTI DWELLING DISTRICT
EAST: LW2 - LIVE-WORK 2 DISTRICT
WEST: LW1 - LIVE-WORK 1 DISTRICT
- LAND USE:
PROPERTY CURRENT LAND USE:
CITY OF KALAMAZOO PUBLIC SAFETY BUILDING
PROPOSED LAND USE NOT CHANGING
ABUTTING PROPERTY LAND USE:
NORTH: VACANT
SOUTH: RESIDENTIAL (NEIGHBORHOOD)
EAST: OPEN SPACE
WEST: COMMERCIAL (RESTAURANTS)
- 2025 MASTER PLAN DEVELOPMENT DESIGNATION OF ADJACENT PARCELS:
PROPERTY LAND ZONE:
NEIGHBORHOOD EDGE
ABUTTING LAND ZONES:
NORTH: URBAN EDGE
SOUTH: NEIGHBORHOOD EDGE
EAST: OPEN SPACE
WEST: NEIGHBORHOOD EDGE
- BUILDING LOCATION FROM PROPERTY LINES:
LOT TYPE: CIVIC
ENTRY TYPE:
BUILDING SETBACK REQUIREMENTS:
FRONT: 0-25'
SIDE: 0'
REAR: 5' (0' OFF ALLEY, 10' ADJACENT TO R DISTRICT)
- SITE IMPERVIOUS COVERAGE:
PRE - DEVELOPED: 204,580 SF (78.1%)
POST - DEVELOPED: 204,221 SF (77.9%)
- PARKING REQUIREMENTS:
REQUIRED:
POLICE/FIRE STATION/UTILITIES & PUBLIC SERVICES
1 PER EMPLOYEE ON LARGEST SHIFT +
0.75 PER FLEET VEHICLE
OFFICE
1 PER 300 SF OF AREA DEDICATED TO OFFICE
REQUIRED CALCULATION:
127 EMPLOYEES + 0.75 (30 VEHICLES) +
9,500 SF OFFICES/3000SF
127 SPACES + 23 SPACES =
182 PARKING SPACES REQUIRED
REQUIRED ADA SPACES **9 REQUIRED SPACES**
SITE PARKING CALCULATIONS
PRE-DEVELOPED: 418 SPACES (16 ADA SPACES)
POST-DEVELOPED: 412 SPACES (14 ADA SPACES)
- BIKE PARKING REQUIREMENTS:
SITE EMPLOYEES: 127 EMPLOYEES
(52 POLICE + 75 CPED)
REQUIRED: 1 BIKE PARKING SPACE PER 7 EMPLOYEES
127 EMPLOYEES/7 EMPLOYEES = 18 SPACES
PROVIDED: 18 SPACES
- SUBJECT PARCEL IS NOT LOCATED WITHIN OR NEAR HISTORIC DISTRICT.
- SUBJECT PARCEL IS NOT WITHIN BROWNFIELD REDEVELOPMENT AUTHORITY
- ACCORDING TO EGLE - RIDE MAPPER, NO SOIL/GROUNDWATER CONTAMINATIONS REPORTED FOR THE SUBJECT PARCEL.
- SUBJECT PARCEL IS NOT WITHIN NATURAL FEATURES PROTECTION
- SUBJECT PARCEL IS WITHIN WELLHEAD PROTECTION AREA
- ACCORDING TO US FISH AND WILDLIFE, SUBJECT SITE CURRENTLY CONTAINS NO WETLANDS.
- ACCORDING TO FEMA FLOOD MAP, 26077C0187E EFF. 7/31/2024, SUBJECT SITE IS WITHIN ZONE AE, ZONE AE INDICATES AN AREA WITH A HIGH RISK OF FLOODING, SPECIFICALLY DURING THE 100-YEAR FLOOD. 100-YEAR BASE FLOOD ELEVATION = 763.30.
- DEWATERING THE SITE NOT ANTICIPATED FOR THIS PROJECT

SURVEYOR'S NOTES

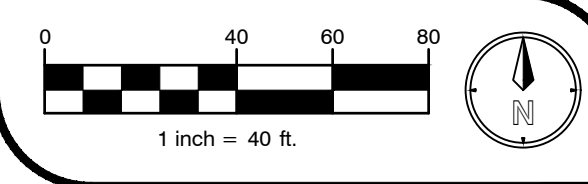
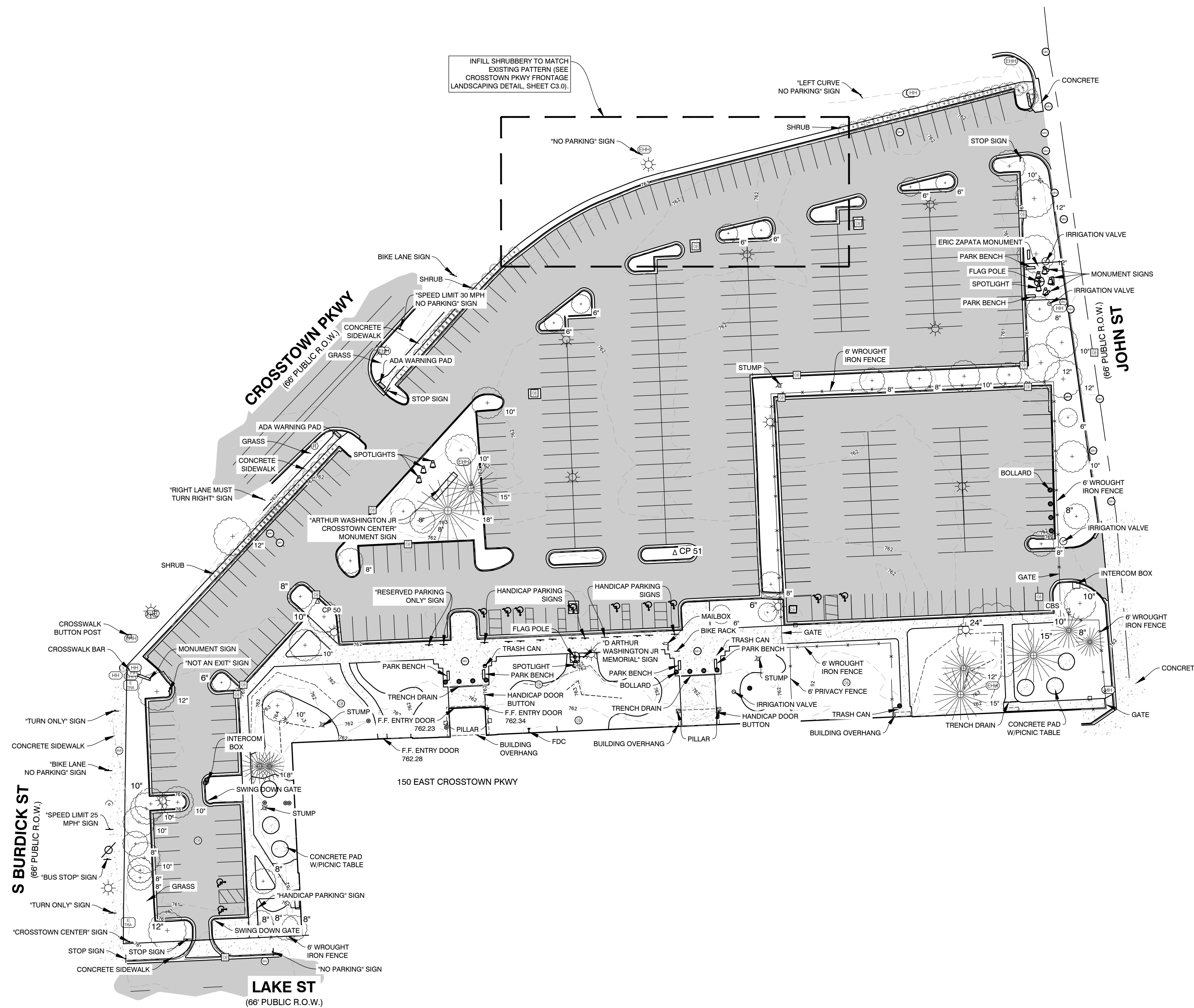
- SUBJECT PROPERTY HAS PEDESTRIAN AND VEHICULAR ACCESS TO E. CROSSTOWN PKWY AND S. BURDICK ST.
- NO CEMETERIES, GRAVE SITES, OR BURIAL GROUNDS WERE DISCLOSED IN THE RECORD DOCUMENTS OR OBSERVED ON THE SURVEYED PROPERTY AT THE TIME OF SURVEY.
- UTILITIES SHOWN HEREON HAVE BEEN LOCATED PER AVAILABLE EVIDENCE ON SITE, OR HAVE BEEN SHOWN PER AVAILABLE MAPS PROVIDED BY UTILITY OWNER AND ARE AN APPROXIMATE LOCATION. ADDITIONAL UTILITIES MAY EXIST BUT ARE UNKNOWN TO THE SURVEYOR.
- SURVEYOR IS NOT AWARE OF ANY CURRENT OR FUTURE RIGHT OF WAY CHANGES.
- NO EVIDENCE OF RECENT STREET, SIDEWALK, EARTHWORK, OR CONSTRUCTION WAS OBSERVED AT THE TIME OF SURVEY.
- NO WETLAND FLAGS WERE OBSERVED AT THE TIME OF SURVEY.
- NO ZONING REPORT WAS PROVIDED AT TIME OF SURVEY.
- (1) 2 STORY CONCRETE BUILDING ON SITE AT TIME OF SURVEY.
- 372 SPACES WERE OBSERVED AT TIME OF SURVEY.
- THE SITE IS LOCATED ON THE SOUTH SIDE OF E CROSSTOWN PKWY.
- THIS SURVEY WAS PERFORMED ON THE GROUND AND ACCURATELY DEPICTS ANY AND ALL OBSERVABLE BUILDINGS, STRUCTURES AND SITE IMPROVEMENTS AND WAS MADE IN ACCORDANCE WITH LAWS AND/OR MINIMUM STANDARDS OF THE STATE OF MICHIGAN. NO VISIBLE ENCROACHMENTS TO THE SUBJECT PROPERTY OR ADJACENT LAND WERE OBSERVED AT TIME OF SURVEY UNLESS OTHERWISE SHOWN HEREON.
- THE VERTICAL RELIEF SHOWN HEREON WAS PERFORMED BY A GROUND SURVEY.
- BEARING BASIS: MICHIGAN STATE PLANE SOUTH ZONE (NAD 83).
- ELEVATION BASIS: NAVD 88.
- NO BOUNDARY SURVEY WAS PERFORMED AT THE TIME OF SURVEY.

LEGEND

	BENCHMARK		YARD DRAIN
	GUY WIRE		FLAG POLE
	LIGHT POLE		SPOTLIGHT
	UTILITY POLE		CONTROL POINT
	CONTROL POINT		MAILBOX
	FLAG POLE		POST
	ELECTRIC HAND HOLE		FIRE DEPARTMENT CONNECTION
	ELECTRIC METER		TRASH CAN
	STORM CATCH BASIN		DECIDUOUS TREE
	SANITARY MANHOLE		CONIFEROUS TREE
	SANITARY CLEANOUT		STUMP
	WATER VALVE		SHRUB
	IRRIGATION VALVE		
	COMMUNICATIONS RISER		
	STORM CATCH BASIN		
	BOLLARD		
	COMMUNICATIONS HANDHOLE		
	ELECTRIC TRANSFORMER		
	ROAD SIGN		

	EXISTING ELECTRIC LINE
	EXISTING FIBER LINE
	EXISTING FENCE

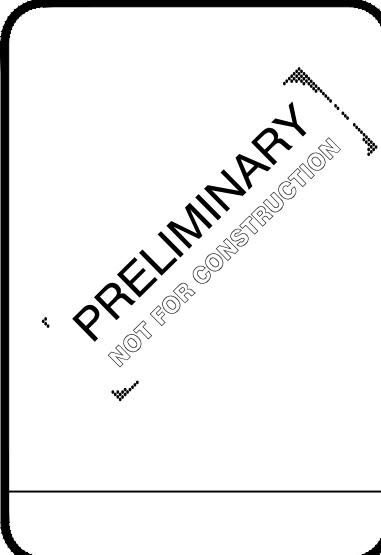
	ASPHALT PAVEMENT
	CONCRETE PAVEMENT AND SIDEWALK
	GRAVEL PAVEMENT
	BRICK PAVERS



PLANS PREPARED BY:



DRAWN: aw
CHECKED: --



No.	ISSUED FOR:	DATE	BY:
0	CHECKLIST MEETING SUBMITTAL	07/31/2025	tc
1	BIDS/SITE PLAN SUBMITTAL	09/08/2025	tc
2			
3			
4			

REPRODUCTION, COPYING OR OTHER USE OF THIS DRAWING WITHOUT WRITTEN CONSENT IS PROHIBITED (AR ENGINEERING - 2025)

EXISTING CONDITIONS
CITY OF KALAMAZOO - CROSSTOWN FACILITY
INTERSECT
150 E CROSSTOWN PARKWAY, KALAMAZOO, MI 49001
SECTION 22, T02S, R11W

PROJECT:
CLIENT:
SITE ADDRESS:
SITE SECTION:

JOB NUMBER
24182004
DATE
09/08/2025

SHEET NUMBER
C1.0



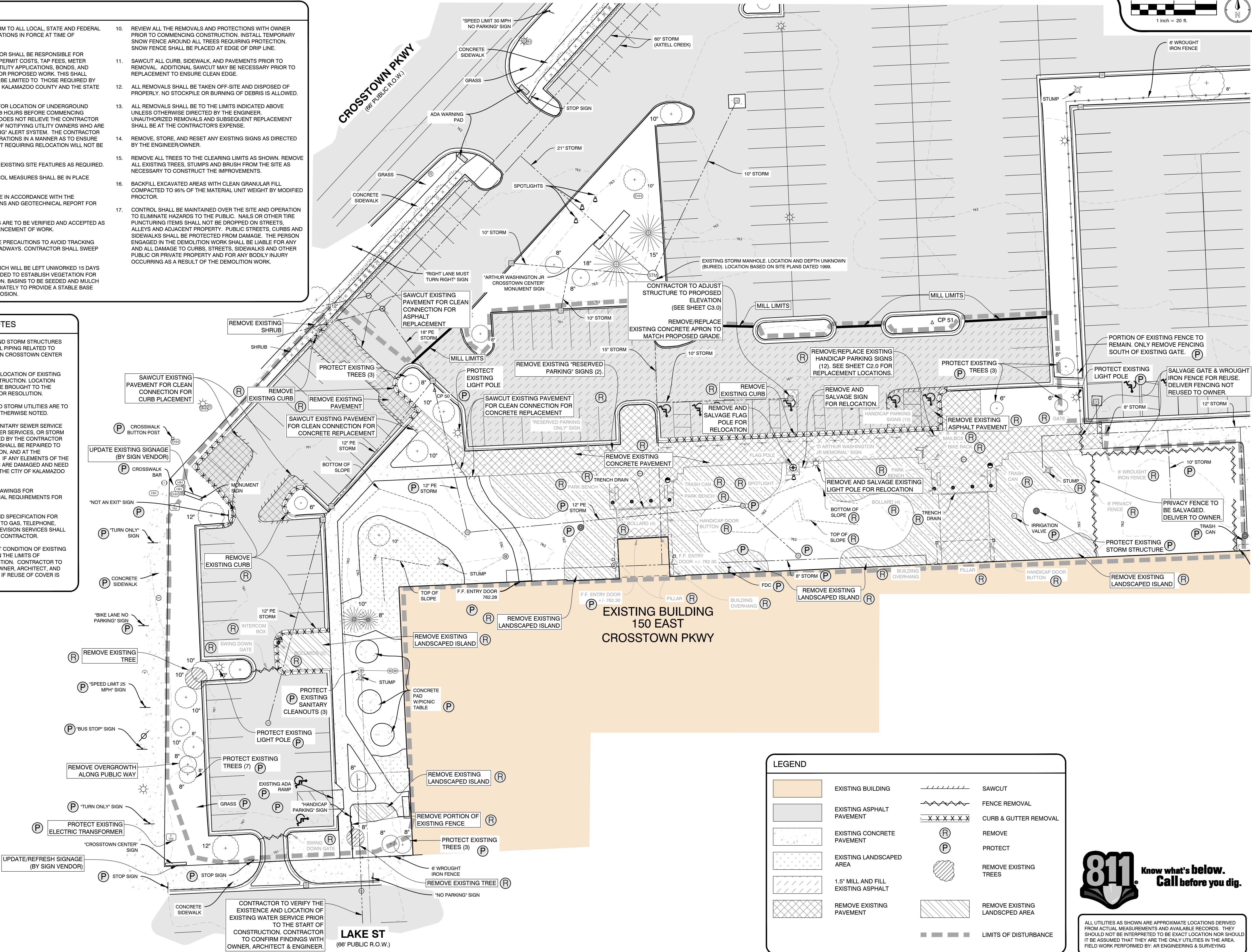
ALL UTILITIES AS SHOWN ARE APPROXIMATE LOCATIONS DERIVED FROM ACTUAL MEASUREMENTS AND AVAILABLE RECORDS. THEY SHOULD NOT BE INTERPRETED TO BE EXACT LOCATION NOR SHOULD IT BE ASSUMED THAT THEY ARE THE ONLY UTILITIES IN THE AREA. FIELD WORK PERFORMED BY: AR ENGINEERING & SURVEYING

DEMOLITION NOTES

- ALL WORK SHALL CONFORM TO ALL LOCAL, STATE AND FEDERAL LAWS, RULES AND REGULATIONS IN FORCE AT TIME OF CONSTRUCTION.
- THE GENERAL CONTRACTOR SHALL BE RESPONSIBLE FOR OBTAINING ALL PERMITS, PERMIT COSTS, TAP FEES, METER DEPOSITS, PERMANENT UTILITY APPLICATIONS, BONDS, AND OTHER FEES REQUIRED FOR PROPOSED WORK. THIS SHALL INCLUDE, BUT SHALL NOT BE LIMITED TO THOSE REQUIRED BY THE CITY OF KALAMAZOO, KALAMAZOO COUNTY AND THE STATE OF MICHIGAN.
- CONTACT MISS DIG "811" FOR LOCATION OF UNDERGROUND UTILITIES A MINIMUM OF 48 HOURS BEFORE COMMENCING EXCAVATION WORK. THIS DOES NOT RELIEVE THE CONTRACTOR OF THE RESPONSIBILITY OF NOTIFYING UTILITY OWNERS WHO ARE NOT PART OF THE "MISS DIG" ALERT SYSTEM. THE CONTRACTOR SHALL CONDUCT HIS OPERATIONS IN A MANNER AS TO ENSURE THAT THOSE UTILITIES NOT REQUIRING RELOCATION WILL NOT BE DISTURBED.
- DEMOLISH & REMOVE ALL EXISTING SITE FEATURES AS REQUIRED.
- ALL SOIL EROSION CONTROL MEASURES SHALL BE IN PLACE PRIOR TO DEMOLITION.
- ALL EXCAVATION SHALL BE IN ACCORDANCE WITH THE TECHNICAL SPECIFICATIONS AND GEOTECHNICAL REPORT FOR THIS SITE.
- ALL EXISTING ELEVATIONS ARE TO BE VERIFIED AND ACCEPTED AS SHOWN PRIOR TO COMMENCEMENT OF WORK.
- CONTRACTOR SHALL TAKE PRECAUTIONS TO AVOID TRACKING SOIL ONTO ADJACENT ROADWAYS. CONTRACTOR SHALL SWEEP IMMEDIATELY IF OCCURS.
- ANY DISTURBED AREA WHICH WILL BE LEFT UNWORKED 15 DAYS OR LONGER MUST BE SEEDED TO ESTABLISH VEGETATION FOR TEMPORARY STABILIZATION. BASINS TO BE SEEDED AND MULCH BLANKETS APPLIED IMMEDIATELY TO PROVIDE A STABLE BASE AND AVOID EXCESSIVE EROSION.
- REVIEW ALL THE REMOVALS AND PROTECTIONS WITH OWNER PRIOR TO COMMENCING CONSTRUCTION. INSTALL TEMPORARY SNOW FENCE AROUND ALL TREES REQUIRING PROTECTION. SNOW FENCE SHALL BE PLACED AT EDGE OF DRIP LINE.
- SAWCUT ALL CURBS, SIDEWALK, AND PAVEMENTS PRIOR TO REMOVAL. ADDITIONAL SAWCUT MAY BE NECESSARY PRIOR TO REPLACEMENT TO ENSURE CLEAN EDGE.
- ALL REMOVALS SHALL BE TAKEN OFF-SITE AND DISPOSED OF PROPERLY. NO STOCKPILE OR BURNING OF DEBRIS IS ALLOWED.
- ALL REMOVALS SHALL BE TO THE LIMITS INDICATED ABOVE UNLESS OTHERWISE DIRECTED BY THE ENGINEER. UNAUTHORIZED REMOVALS AND SUBSEQUENT REPLACEMENT SHALL BE AT THE CONTRACTOR'S EXPENSE.
- REMOVE, STORE, AND RESET ANY EXISTING SIGNS AS DIRECTED BY THE ENGINEER/OWNER.
- REMOVE ALL TREES TO THE CLEARING LIMITS AS SHOWN. REMOVE ALL EXISTING TREES, STUMPS AND BRUSH FROM THE SITE AS NECESSARY TO CONSTRUCT THE IMPROVEMENTS.
- BACKFILL EXCAVATED AREAS WITH CLEAN GRANULAR FILL COMPACTED TO 95% OF THE MATERIAL UNIT WEIGHT BY MODIFIED PROCTOR.
- CONTROL SHALL BE MAINTAINED OVER THE SITE AND OPERATION TO ELIMINATE HAZARDS TO THE PUBLIC. NAILS OR OTHER TIRE PUNCTURING ITEMS SHALL NOT BE DROPPED ON STREETS, ALLEYS AND ADJACENT PROPERTY. PUBLIC STREETS, CURBS AND SIDEWALKS SHALL BE PROTECTED FROM DAMAGE. THE PERSON ENGAGED IN THE DEMOLITION WORK SHALL BE LIABLE FOR ANY AND ALL DAMAGE TO CURBS, STREETS, SIDEWALKS AND OTHER PUBLIC OR PRIVATE PROPERTY AND FOR ANY BODILY INJURY OCCURRING AS A RESULT OF THE DEMOLITION WORK.

EXISTING UTILITY NOTES

- ALL WATER, SANITARY, AND STORM STRUCTURES SHOWN AS SURVEYED. ALL PIPING RELATED TO THESE UTILITIES BASED ON CROSSTOWN CENTER PLANS DATED 11/30/2000.
- CONTRACTOR TO VERIFY LOCATION OF EXISTING UTILITIES PRIOR TO CONSTRUCTION. LOCATION DISCREPANCIES ARE TO BE BROUGHT TO THE ENGINEER'S ATTENTION FOR RESOLUTION.
- ALL WATER, SANITARY AND STORM UTILITIES ARE TO BE PROTECTED UNLESS OTHERWISE NOTED.
- ANY SANITARY SEWER, SANITARY SEWER SERVICE LEADS, WATER MAIN, WATER SERVICES, OR STORM SEWER WHICH IS DAMAGED BY THE CONTRACTOR DURING HIS OPERATIONS SHALL BE REPAIRED TO THE OWNERS SATISFACTION, AND AT THE CONTRACTOR'S EXPENSE. IF ANY ELEMENTS OF THE SANITARY SEWER SYSTEM ARE DAMAGED AND NEED REPAIRED, IT MUST MEET THE CITY OF KALAMAZOO SPECIFICATIONS.
- REFER TO ELECTRICAL DRAWINGS FOR UNDERGROUND ELECTRICAL REQUIREMENTS FOR SITE.
- DESIGN, INSTALLATION AND SPECIFICATION FOR IMPROVEMENTS RELATED TO GAS, TELEPHONE, ELECTRIC AND CABLE TELEVISION SERVICES SHALL BE COORDINATED BY THE CONTRACTOR.
- CONTRACTOR TO INSPECT CONDITION OF EXISTING MANHOLE COVERS WITHIN THE LIMITS OF DISTURBANCE/CONSTRUCTION. CONTRACTOR TO REPORT CONDITION TO OWNER, ARCHITECT, AND ENGINEER TO DETERMINE IF REUSE OF COVER IS ACCEPTABLE.



LEGEND

	EXISTING BUILDING		SAWCUT
	EXISTING ASPHALT PAVEMENT		FENCE REMOVAL
	EXISTING CONCRETE PAVEMENT		CURB & GUTTER REMOVAL
	EXISTING LANDSCAPED AREA		REMOVE
	1.5" MILL AND FILL EXISTING ASPHALT		PROTECT
	REMOVE EXISTING PAVEMENT		REMOVE EXISTING TREES
			REMOVE EXISTING LANDSCAPED AREA
			LIMITS OF DISTURBANCE

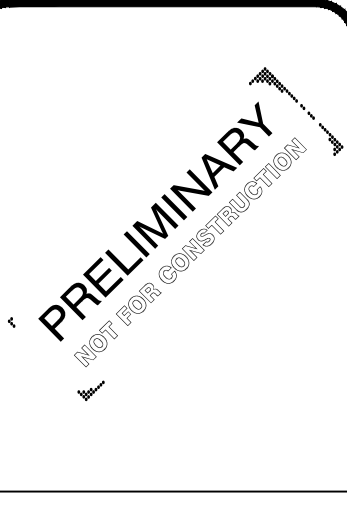


ALL UTILITIES AS SHOWN ARE APPROXIMATE LOCATIONS DERIVED FROM ACTUAL MEASUREMENTS AND AVAILABLE RECORDS. THEY SHOULD NOT BE INTERPRETED TO BE EXACT LOCATION NOR SHOULD IT BE ASSUMED THAT THEY ARE THE ONLY UTILITIES IN THE AREA. FIELD WORK PERFORMED BY: AR ENGINEERING & SURVEYING

PLANS PREPARED BY:



DRAWN: aw
CHECKED: --



No.	ISSUED FOR:	DATE	BY:
0	CHECKLIST MEETING SUBMITTAL	07/31/2025	tc
1	BIDS/SITE PLAN SUBMITTAL	09/08/2025	tc
2			
3			
4			

DEMOLITION PLAN
CITY OF KALAMAZOO - CROSSTOWN FACILITY
INTERSECT
150 E CROSSTOWN PARKWAY, KALAMAZOO, MI 49001
SECTION 22, T02S, R11W

JOB NUMBER
24182004
DATE
09/08/2025

SHEET NUMBER
C1.1

GRADING - SESC NOTES

- MATCH EXISTING GRADES AROUND PERIMETER WITH SLOPES AS SHOWN.
- ALL SPOT ELEVATIONS ARE TOP OF PAVEMENT GRADES AT EDGE OF METAL (EOM) UNLESS OTHERWISE NOTED.
- ALL SOIL EROSION CONTROL MEASURES SHALL BE IN PLACE PRIOR TO MASS GRADING.
- ALL EXISTING ELEVATIONS ARE TO BE VERIFIED AND ACCEPTED AS SHOWN PRIOR TO COMMENCEMENT OF WORK.
- CONTRACTOR SHALL TAKE PRECAUTIONS TO AVOID TRACKING SOIL ONTO ADJACENT ROADWAYS. CONTRACTOR SHALL SWEEP IMMEDIATELY IF OCCURS.
- ANY DISTURBED AREA WHICH WILL BE LEFT UNWORKED 15 DAYS OR LONGER MUST BE SEED TO ESTABLISH VEGETATION FOR TEMPORARY STABILIZATION. BASINS TO BE SEED AND MULCH BLANKETS APPLIED IMMEDIATELY TO PROVIDE A STABLE BASE AND AVOID EXCESSIVE EROSION.
- PROPOSED GRADES SHALL REMAIN CONSISTENT TO THE GRADES OF THE EXISTING SITE, UNLESS OTHERWISE NOTED.

GRASS SPECIES LEGEND

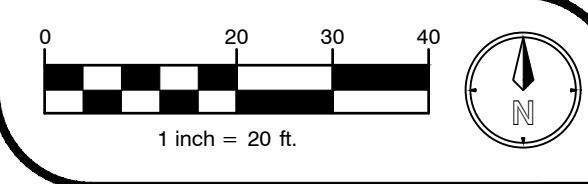
- PENNSYLVANIA SEDGE
- PENNSYLVANIA SEDGE OR OTHER ORNAMENTAL GRASS UP TO 18" TALL
- JAPANESE FOREST GRASS
- OSTRICH FERN
- REPLANT SALVAGED ORNAMENTAL GRASSES FROM AREAS OF CONSTRUCTION

Shrub Planting Schedule

Symbol	Latin Name	Common Name	Size	Container Type
Gb	Buxus 'Green Gem'	Green Gem Boxwood	24" Ht.	B&B or Cont.
Fr	Calamagrostis x acutiflora	Feather Reed Grass	24" Ht.	B&B or Cont.
An	Andropogon gerardii Vitman	Big Bluestem	24" Ht.	B&B or Cont.
Av	Viburnum dentatum	Arrowwood Viburnum	24" Ht.	B&B or Cont.
Bh	Hosta sieboldiana 'Elegans'	Big Blue Hosta	24" Ht.	B&B or Cont.
Bb	Andropogon gerardii	Big Bluestem	5' Ht.	B&B Or Cont.
Sp	Spiraea x bumalda 'Goldflame'	Goldflame Spirea	24" Ht.	3-5 gallon Cont.

Tree Planting Schedule

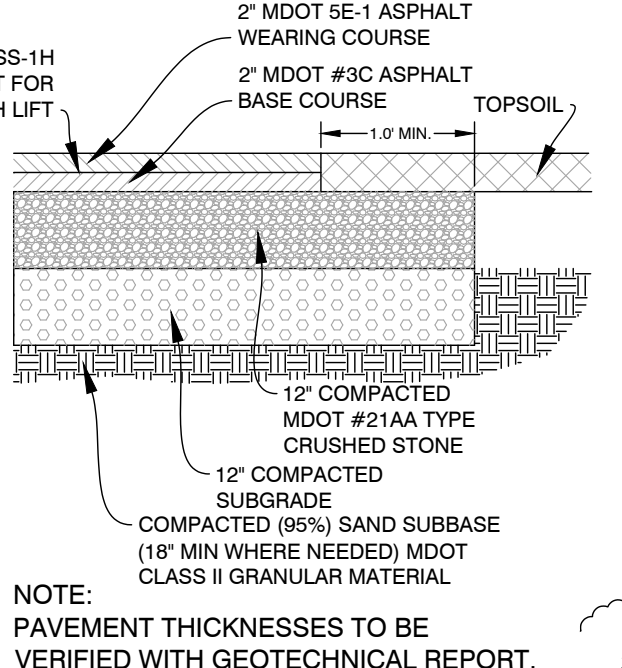
Symbol	Latin Name	Common Name	Size	Container Type
Jv	Juniperus virginiana	Eastern Red Cedar	6-8'	B&B
Sg	Liquidambar styraciflua	Sweetgum	2.5" Cal.	B&B
Cb	Carpinus betulus 'Frans Fontaine'	Frans Fontaine Hornbeam	2.5" Cal.	B&B
Eg	Thuja occidentalis 'Smaragd'	Emerald Green Arborvitae	2.5" Cal.	B&B
Ds	Amelanchier arborea (Michx. f.) Fern	Downy Serviceberry	2.5" Cal.	B&B
Qu	Quercus palustris Muenchh	Pin Oak	2.5" Cal.	B&B



SOIL EROSION & SEDIMENT CONTROL NOTES

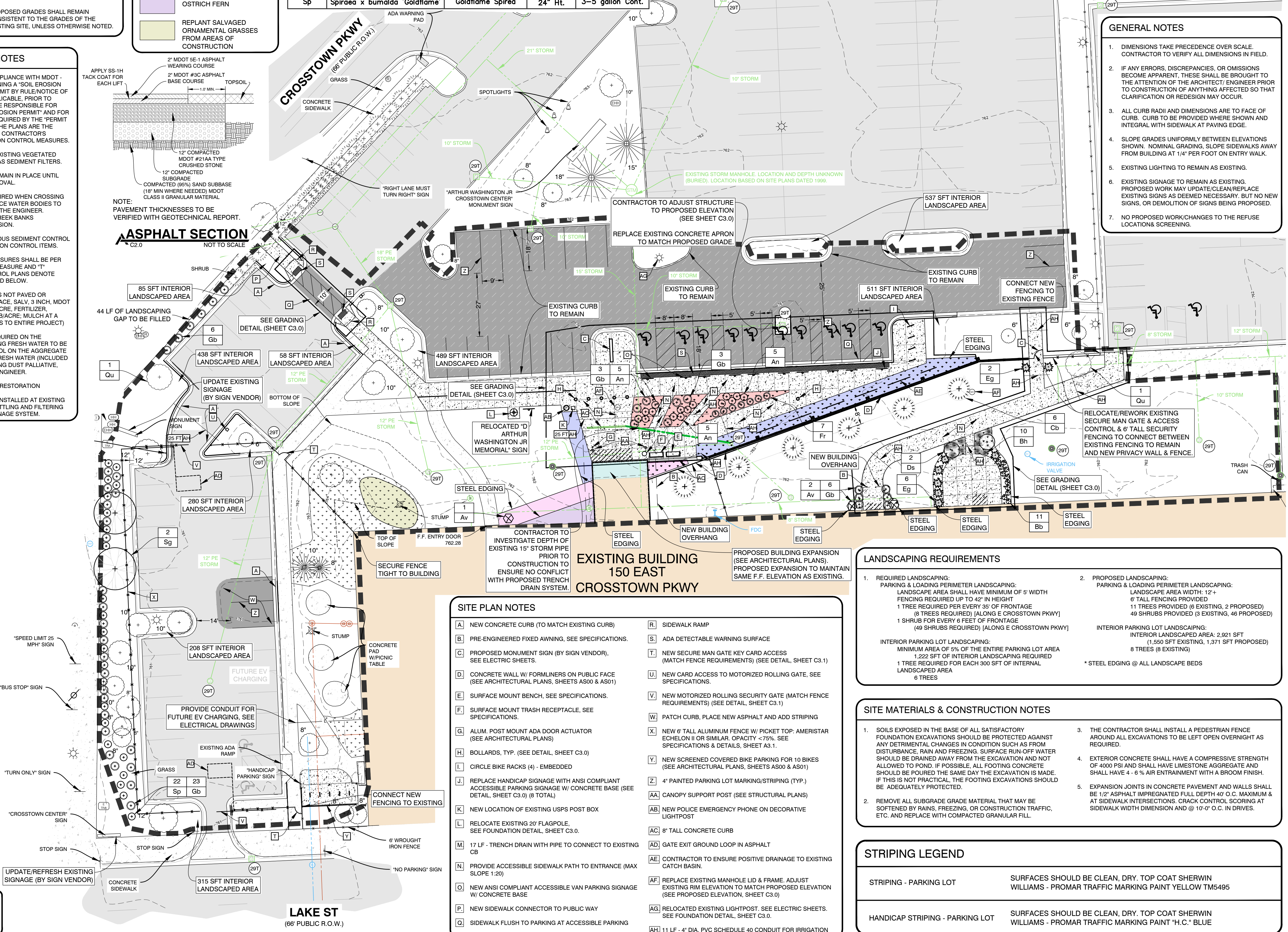
- ALL CONSTRUCTION METHODS SHALL BE DONE IN COMPLIANCE WITH MDT - EGLE. THE OWNER SHALL BE RESPONSIBLE FOR OBTAINING A 'SOIL EROSION PERMIT' FROM THE GOVERNING AUTHORITY AND A 'PERMIT BY RULE/NOTICE OF COVERAGE' FROM THE GOVERNING AUTHORITY, IF APPLICABLE, PRIOR TO START OF CONSTRUCTION. THE CONTRACTOR SHALL BE RESPONSIBLE FOR COMPLYING WITH ALL REQUIREMENTS OF THE 'SOIL EROSION PERMIT' AND FOR ALL CERTIFIED STORM WATER INSPECTION SERVICE REQUIRED BY THE 'PERMIT BY RULE.' EROSION CONTROL MEASURES SHOWN ON THE PLANS ARE THE MINIMUM REQUIREMENTS AND SHALL NOT RELIEVE THE CONTRACTORS RESPONSIBILITY FOR PROVIDING ALL REQUIRED EROSION CONTROL MEASURES.
 - AVOID UNNECESSARY DISTURBING OR REMOVING OF EXISTING VEGETATED TOPSOIL OR EARTH COVER, THESE COVER AREAS ACT AS SEDIMENT FILTERS.
 - ALL TEMPORARY SOIL EROSION PROTECTION SHALL REMAIN IN PLACE UNTIL REMOVAL IS REQUIRED FOR FINAL CLEAN UP AND APPROVAL.
 - GEOTEXTILE SILT FENCE SHALL BE INSTALLED AS REQUIRED WHEN CROSSING CREEKS OR WHEN ADJACENT TO WETLANDS OR SURFACE WATER BODIES TO PREVENT SILTATION AND ELSEWHERE AS DIRECTED BY THE ENGINEER. SEEDING AND/OR SOILING SHALL BE INSTALLED ON GREEK BANKS IMMEDIATELY AFTER CONSTRUCTION TO PREVENT EROSION.
 - MAINTENANCE, CLEANING, AND REMOVAL OF THE VARIOUS SEDIMENT CONTROL MEASURES SHALL BE INCLUDED IN THE VARIOUS EROSION CONTROL ITEMS.
- ALL SOIL EROSION AND SEDIMENTATION CONTROL MEASURES SHALL BE PER MDT STANDARD DETAILS. "P" DENOTES PERMANENT MEASURE AND "T" DENOTES TEMPORARY MEASURE. SOIL EROSION CONTROL PLANS DENOTE MINIMUM EROSION MEASURES REQUIRED AS DESCRIBED BELOW.
- DENOTES PERMANENT SEEDING. ALL DISTURBED AREAS NOT PAVED OR GRAVELED SHALL BE RESTORED. PLACE TOPSOIL SURFACE, SALV. 3 INCH. MDT SEEDING MIXTURE TUF APPLIED AT A RATE OF 220 LB/ACRE, FERTILIZER, CHEMICAL NUTRIENT. CL A APPLIED AT A RATE OF 228 LB/ACRE; MULCH AT A RATE OF 2 TON/ACRE AND MULCH ANCHORING. (APPLIES TO ENTIRE PROJECT)
- DENOTES DUST CONTROL. DUST CONTROL MAY BE REQUIRED ON THE SUBGRADE CONSTRUCTION AND WILL INCLUDE APPLYING FRESH WATER TO BE INCLUDED IN THE ITEM OF EMBANKMENT. DUST CONTROL ON THE AGGREGATE BASE COURSE WILL BE ACCOMPLISHED BY APPLYING FRESH WATER (INCLUDED IN THE ITEM OF AGGREGATE BASE, 6 INCH) AND APPLYING DUST PALLIATIVE, APPLIED, CaCl₂ (TON) AS DIRECTED BY THE PROJECT ENGINEER.
- DENOTES AGGREGATE COVER/PERMANENT PAVEMENT RESTORATION
- DENOTES INLET PROTECTION FABRIC DROP. SHALL BE INSTALLED AT EXISTING AND PROPOSED STORM SEWER INLETS TO PROVIDE SETTLING AND FILTERING OF SILT LADEN WATER PRIOR TO ENTRY INTO THE DRAINAGE SYSTEM.

ASPHALT SECTION
NOT TO SCALE



LEGEND

- EXISTING BUILDING
- EXISTING ASPHALT PAVEMENT
- EXISTING CONCRETE PAVEMENT
- EXISTING LANDSCAPED AREA
- PROPOSED BUILDING ADDITION TO ENTRANCE
- PROPOSED ASPHALT FULL DEPTH REPLACEMENT (SEE DETAIL, THIS SHEET)
- PROPOSED ASPHALT 1.5" MILL AND OVERLAY REPLACEMENT. USE MDT 05-1 ASPHALT WEARING COURSE
- PROPOSED CONCRETE PAVEMENT
- PROPOSED NEW LANDSCAPED AREA
- FROST SLAB, SEE STRUCTURAL SHEETS
- PROPOSED CURB (TO MATCH EXISTING CURB)
- LIMITS OF DISTURBANCE
- NUMBER AND TYPE OF PLANTS TO BE PROVIDED AND INSTALLED



GENERAL NOTES

- DIMENSIONS TAKE PRECEDENCE OVER SCALE. CONTRACTOR TO VERIFY ALL DIMENSIONS IN FIELD.
- IF ANY ERRORS, DISCREPANCIES, OR OMISSIONS BECOME APPARENT, THESE SHALL BE BROUGHT TO THE ATTENTION OF THE ARCHITECT/ENGINEER PRIOR TO CONSTRUCTION OF ANYTHING AFFECTED SO THAT CLARIFICATION OR REDESIGN MAY OCCUR.
- ALL CURB RADI AND DIMENSIONS ARE TO FACE OF CURB. CURB TO BE PROVIDED WHERE SHOWN AND INTEGRAL WITH SIDEWALK AT PAVING EDGE.
- SLOPE GRADES UNIFORMLY BETWEEN ELEVATIONS SHOWN. NOMINAL GRADING, SLOPE SIDEWAYS AWAY FROM BUILDING AT 1/4" PER FOOT ON ENTRY WALK.
- EXISTING LIGHTING TO REMAIN AS EXISTING.
- EXISTING SIGNAGE TO REMAIN AS EXISTING. PROPOSED WORK MAY UPDATE/CLEAN/REPLACE EXISTING SIGNS AS DEEMED NECESSARY, BUT NO NEW SIGNS, OR DEMOLITION OF SIGNS BEING PROPOSED.
- NO PROPOSED WORK/CHANGES TO THE REFUSE LOCATION & SCREENING.



ALL UTILITIES AS SHOWN ARE APPROXIMATE LOCATIONS DERIVED FROM ACTUAL MEASUREMENTS AND AVAILABLE RECORDS. THEY SHOULD NOT BE INTERPRETED TO BE EXACT LOCATION NOR SHOULD IT BE ASSUMED THAT THEY ARE THE ONLY UTILITIES IN THE AREA. FIELD WORK PERFORMED BY: AR ENGINEERING & SURVEYING

SITE PLAN NOTES

- A NEW CONCRETE CURB (TO MATCH EXISTING CURB)
- B PRE-ENGINEERED FIXED AWNING, SEE SPECIFICATIONS.
- C PROPOSED MONUMENT SIGN (BY SIGN VENDOR), SEE ELECTRICAL SHEETS.
- D CONCRETE WALL W/ FORMLINERS ON PUBLIC FACE (SEE ARCHITECTURAL PLANS, SHEETS AS00 & AS01)
- E SURFACE MOUNT BENCH, SEE SPECIFICATIONS.
- F SURFACE MOUNT TRASH RECEPTACLE, SEE SPECIFICATIONS.
- G ALUM. POST MOUNT ADA DOOR ACTUATOR (SEE ARCHITECTURAL PLANS)
- H BOLLARDS, TYP. (SEE DETAIL, SHEET C3.0)
- L CIRCLE BIKE RACKS (4) - EMBEDDED
- J REPLACE HANDICAP SIGNAGE WITH ANSI COMPLIANT ACCESSIBLE PARKING SIGNAGE W/ CONCRETE BASE (SEE DETAIL, SHEET C3.0) (8 TOTAL)
- K NEW LOCATION OF EXISTING USPS POST BOX
- L RELOCATE EXISTING 20' FLAGPOLE, SEE FOUNDATION DETAIL, SHEET C3.0.
- M 17 LF - TRENCH DRAIN WITH PIPE TO CONNECT TO EXISTING CB
- N PROVIDE ACCESSIBLE SIDEWALK PATH TO ENTRANCE (MAX SLOPE 1:20)
- O NEW ANSI COMPLIANT ACCESSIBLE VAN PARKING SIGNAGE W/ CONCRETE BASE
- P NEW SIDEWALK CONNECTOR TO PUBLIC WAY
- Q SIDEWALK FLUSH TO PARKING AT ACCESSIBLE PARKING
- R SIDEWALK RAMP
- S ADA DETECTABLE WARNING SURFACE
- T NEW SECURE MAN GATE KEY CARD ACCESS (MATCH FENCE REQUIREMENTS) (SEE DETAIL, SHEET C3.1)
- U NEW CARD ACCESS TO MOTORIZED ROLLING GATE, SEE SPECIFICATIONS.
- V NEW MOTORIZED ROLLING SECURITY GATE (MATCH FENCE REQUIREMENTS) (SEE DETAIL, SHEET C3.1)
- W PATCH CURB, PLACE NEW ASPHALT AND ADD STRIPING
- X NEW 6' TALL ALUMINUM FENCE W/ PICKET TOP; AMERISTAR ECHOLON II OR SIMILAR. OPACITY <75%. SEE SPECIFICATIONS & DETAILS, SHEET AS.3.1.
- Y NEW SCREENED COVERED BIKE PARKING FOR 10 BIKES (SEE ARCHITECTURAL PLANS, SHEETS AS00 & AS01)
- Z 4' PAINTED PARKING LOT MARKING/STRIPING (TYP.)
- AA CANOPY SUPPORT POST (SEE STRUCTURAL PLANS)
- AB NEW POLICE EMERGENCY PHONE ON DECORATIVE LIGHTPOST
- AC 8" TALL CONCRETE CURB
- AD GATE EXIT GROUND LOOP IN ASPHALT
- AE CONTRACTOR TO ENSURE POSITIVE DRAINAGE TO EXISTING CATCH BASIN.
- AF REPLACE EXISTING MANHOLE LID & FRAME. ADJUST EXISTING RIM ELEVATION TO MATCH PROPOSED ELEVATION (SEE PROPOSED ELEVATION, SHEET C3.0)
- AG RELOCATED EXISTING LIGHTPOST. SEE ELECTRICAL SHEETS. SEE FOUNDATION DETAIL, SHEET C3.0.
- AH 11 LF - 4" DIA. PVC SCHEDULE 40 CONDUIT FOR IRRIGATION

LANDSCAPING REQUIREMENTS

- REQUIRED LANDSCAPING: PARKING & LOADING PERIMETER LANDSCAPING: LANDSCAPE AREA SHALL HAVE MINIMUM OF 5' WIDTH FENCING REQUIRED UP TO 42" IN HEIGHT
1 TREE REQUIRED PER EVERY 35' OF FRONTAGE (8 TREES REQUIRED) (ALONG E CROSSTOWN PKWY)
1 SHRUB FOR EVERY 6 FEET OF FRONTAGE (49 SHRUBS REQUIRED) (ALONG E CROSSTOWN PKWY)
 - PROPOSED LANDSCAPING: PARKING & LOADING PERIMETER LANDSCAPING: LANDSCAPE AREA WIDTH: 12' + 6' TALL FENCING PROVIDED
11 TREES PROVIDED (8 EXISTING, 2 PROPOSED)
49 SHRUBS PROVIDED (3 EXISTING, 46 PROPOSED)
- INTERIOR PARKING LOT LANDSCAPING:
MINIMUM AREA OF 3% OF THE ENTIRE PARKING LOT AREA
1,222 SFT OF INTERIOR LANDSCAPING REQUIRED
1 TREE REQUIRED FOR EACH 300 SFT OF INTERNAL LANDSCAPED AREA
6 TREES
- INTERIOR LANDSCAPED AREA: 2,921 SFT (1,550 SFT EXISTING, 1,371 SFT PROPOSED)
8 TREES (8 EXISTING)
* STEEL EDGING @ ALL LANDSCAPE BEDS

SITE MATERIALS & CONSTRUCTION NOTES

- SOILS EXPOSED IN THE BASE OF ALL SATISFACTORY FOUNDATION EXCAVATIONS SHOULD BE PROTECTED AGAINST ANY DETRIMENTAL CHANGES IN CONDITION SUCH AS FROM DISTURBANCE, RAIN AND FREEZING. SURFACE RUN-OFF WATER SHOULD BE DRAINED AWAY FROM THE EXCAVATION AND NOT ALLOWED TO POND. IF POSSIBLE, ALL FOOTING CONCRETE SHOULD BE POURED THE SAME DAY THE EXCAVATION IS MADE. IF THIS IS NOT PRACTICAL, THE FOOTING EXCAVATIONS SHOULD BE ADEQUATELY PROTECTED.
- REMOVE ALL SUBGRADE GRADE MATERIAL THAT MAY BE SOFTENED BY RAINS, FREEZING, OR CONSTRUCTION TRAFFIC, ETC. AND REPLACE WITH COMPACTED GRANULAR FILL.
- THE CONTRACTOR SHALL INSTALL A PEDESTRIAN FENCE AROUND ALL EXCAVATIONS TO BE LEFT OPEN OVERNIGHT AS REQUIRED.
- EXTERIOR CONCRETE SHALL HAVE A COMPRESSIVE STRENGTH OF 4000 PSI AND SHALL HAVE LIMESTONE AGGREGATE AND SHALL HAVE 4 - 6 % AIR ENTRAINMENT WITH A BROOM FINISH.
- EXPANSION JOINTS IN CONCRETE PAVEMENT AND WALLS SHALL BE 1/2" ASPHALT IMPREGNATED FULL DEPTH 40" O.C. MAXIMUM & AT SIDEWALK INTERSECTIONS, CRACK CONTROL SCORING AT SIDEWALK WIDTH DIMENSION AND @ 10'-0" O.C. IN DRIVES.

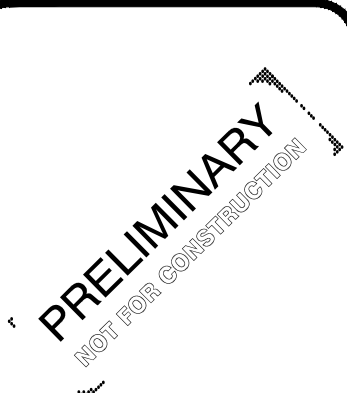
STRIPING LEGEND

- STRIPING - PARKING LOT SURFACES SHOULD BE CLEAN, DRY. TOP COAT SHERWIN WILLIAMS - PROMAR TRAFFIC MARKING PAINT YELLOW TM5495
- HANDICAP STRIPING - PARKING LOT SURFACES SHOULD BE CLEAN, DRY. TOP COAT SHERWIN WILLIAMS - PROMAR TRAFFIC MARKING PAINT "H.C." BLUE

PLANS PREPARED BY:



DRAWN: aw
CHECKED: --

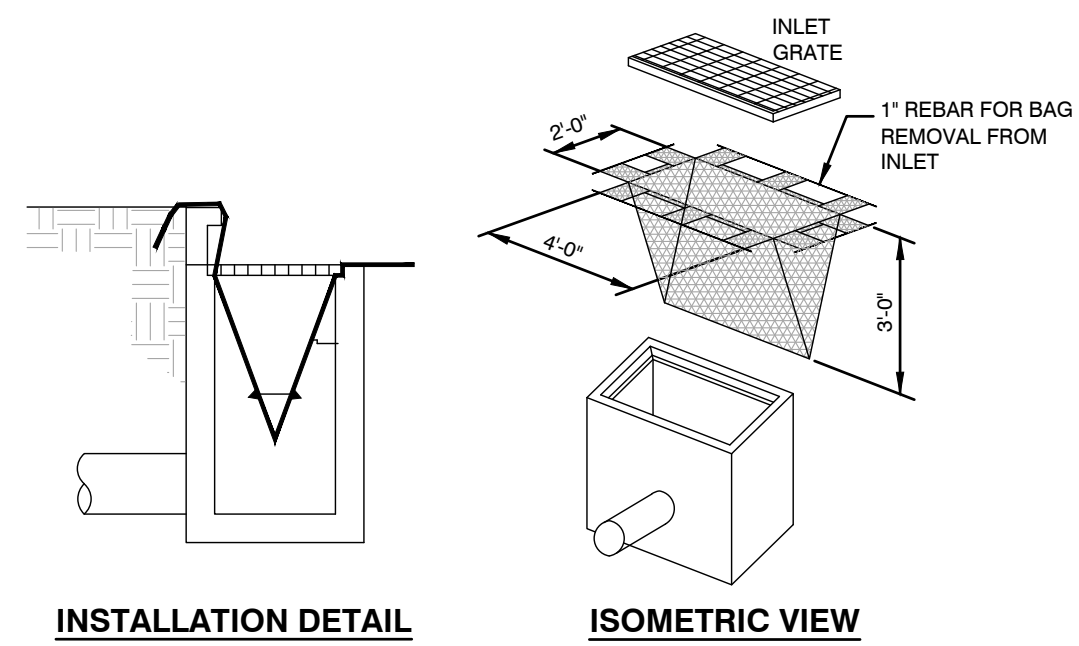


No.	ISSUED FOR:	DATE	BY:
0	CHECKLIST MEETING SUBMITTAL	07/31/2025	lc
1	BIDS/SITE PLAN SUBMITTAL	09/08/2025	lc
2			
3			
4			

SITE LAYOUT PLAN
CITY OF KALAMAZOO - CROSSTOWN FACILITY INTERSECT
150 E CROSSTOWN PARKWAY, KALAMAZOO, MI 49001
SECTION 22, T02S, R11W

JOB NUMBER
24182004
DATE
09/08/2025

SHEET NUMBER
C2.0



WHEN:
WHEN SEDIMENT LADEN STORMWATER REQUIRES TREATMENT BEFORE ENTERING A STORM WATER DRAINAGE SYSTEM.

WHY:
TO PREVENT SEDIMENT FROM ENTERING STORM WATER SYSTEMS.

WHERE:
USE IN OR AT STORM WATER INLETS, ESPECIALLY AT CONSTRUCTION SITES OR IN STREETS.

HOW:

1. A FILTER FABRIC BAG IS HUNG INSIDE THE INLET, BENEATH THE GRATE.
2. REPLACE GRATE, WHICH WILL HOLD BAG IN PLACE.
3. ANCHOR FILTER BAG WITH 1\"/>

MAINTENANCE:
DROP INLET FILTERS SHOULD BE INSPECTED ROUTINELY AND AFTER EACH MAJOR RAIN EVENT.

DAMAGED FILTER BAGS SHOULD BE REPLACED.

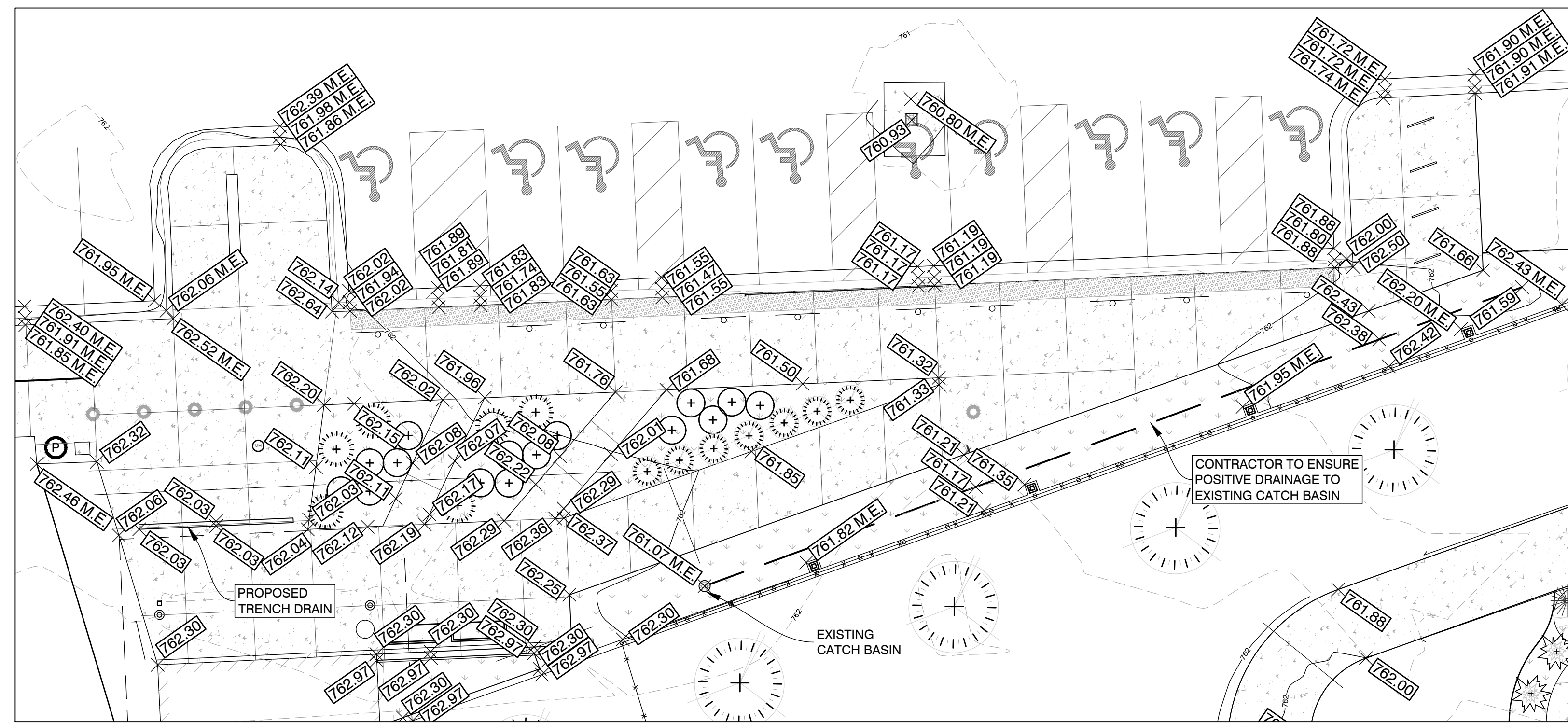
CLEAN AND/OR REPLACE FILTER BAG WHEN 1/2 FULL.

REPLACE CLOGGED FABRIC IMMEDIATELY.

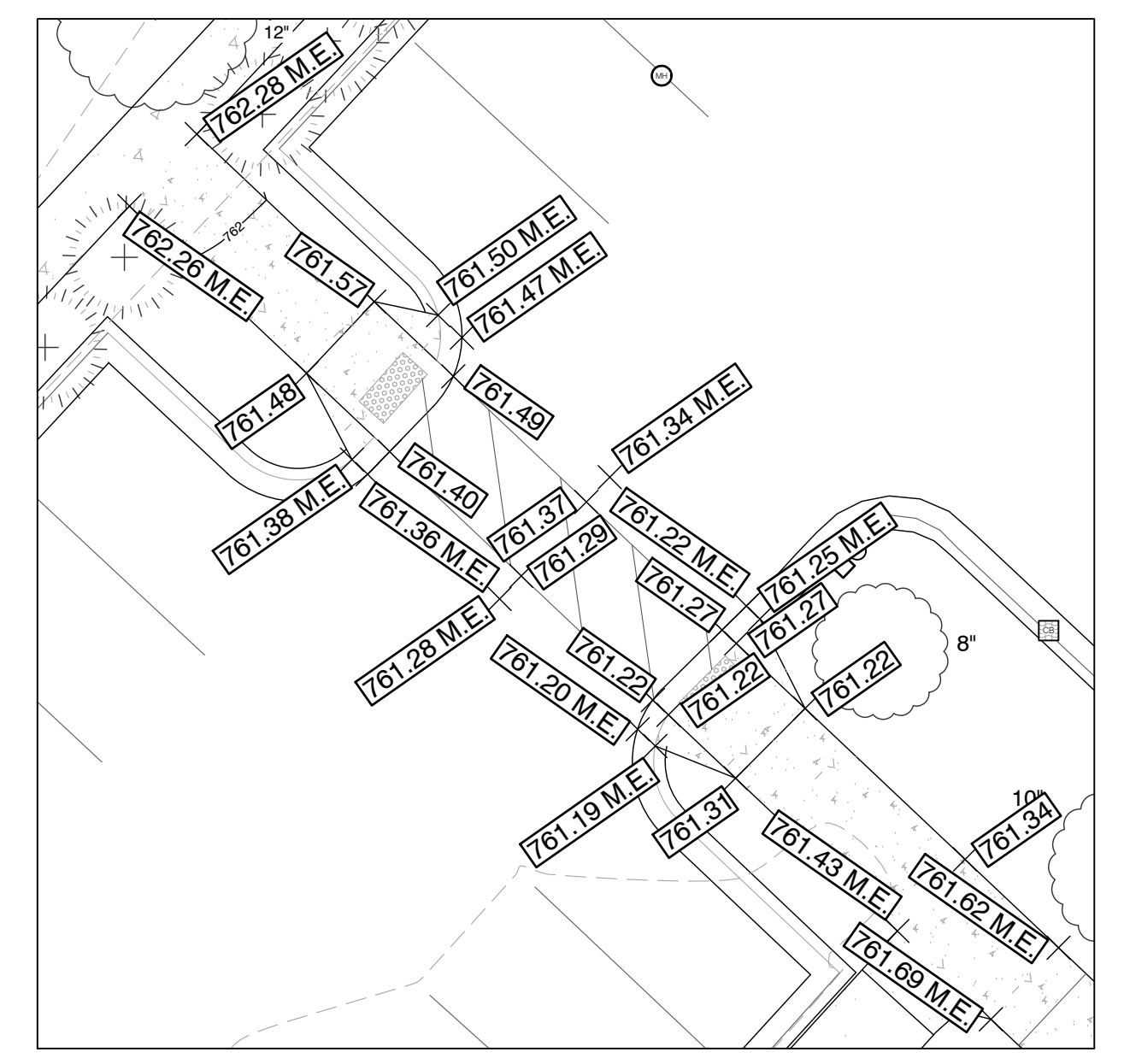
IF NEEDED, INITIATE REPAIRS IMMEDIATELY UPON INSPECTION.

REMOVE ENTIRE PROTECTIVE MECHANISM WHEN UPGRADE AREAS ARE STABILIZED AND STREETS HAVE BEEN SWEEPED.

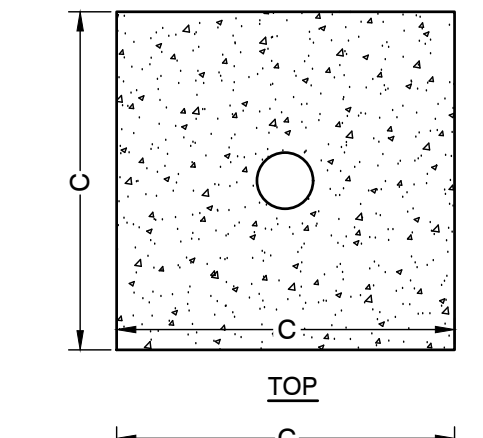
INLET PROTECTION - SILT SACK
C3.0 NOT TO SCALE



ADA CROSSWALK GRADING DETAIL
C3.0 1 INCH = 10 FEET

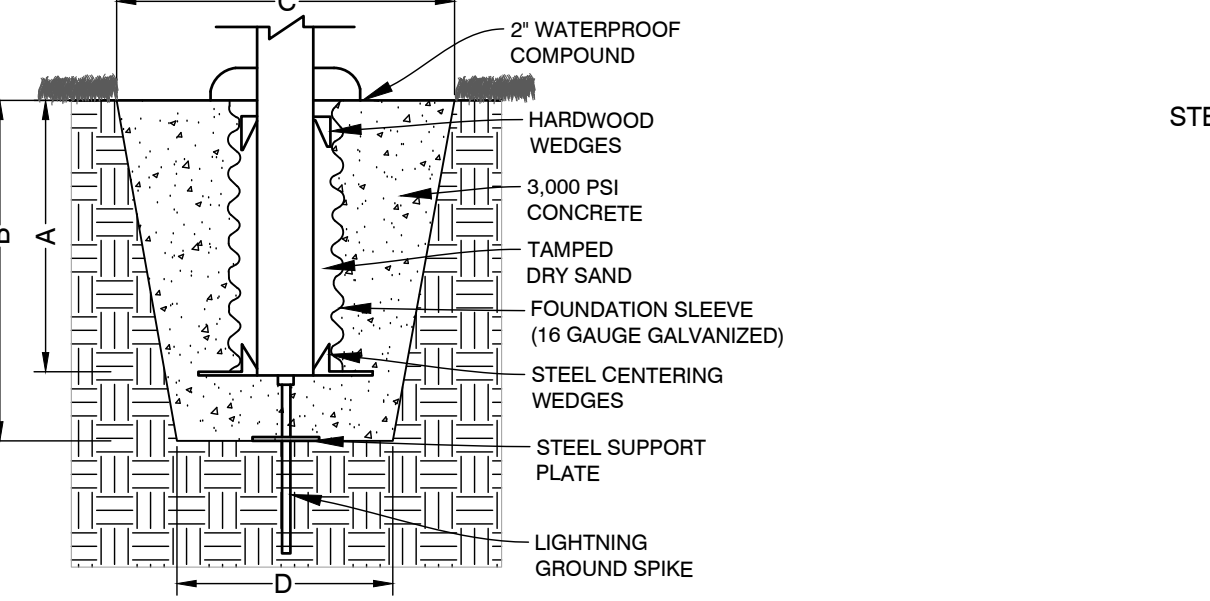


ADA CROSSWALK GRADING DETAIL
C3.0 1 INCH = 10 FEET

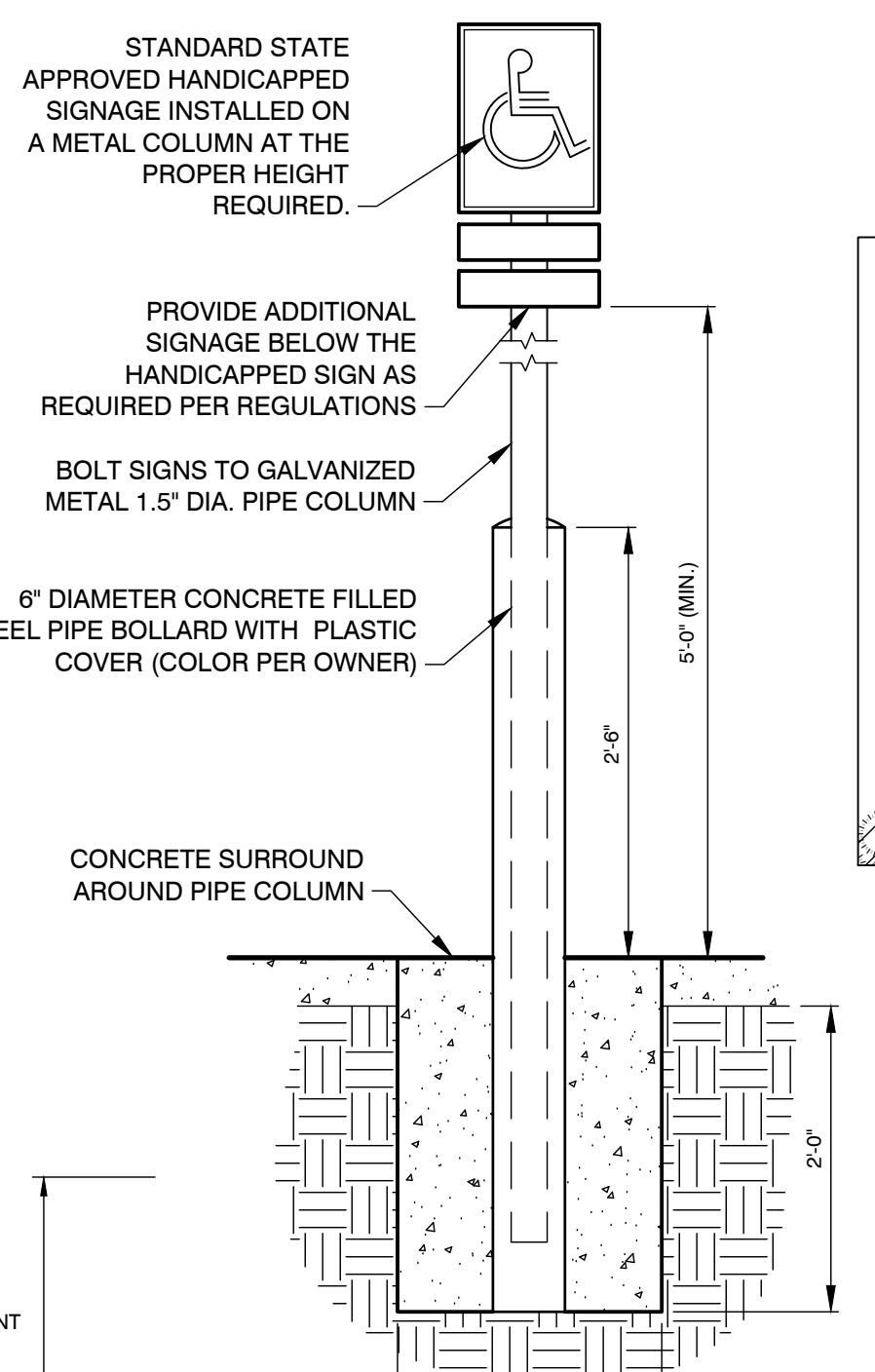


NOTE:
CONTRACTOR TO REUSE EXISTING FLAG POLE. CONTRACTOR TO BASE DIMENSIONS ON MOUNTING HEIGHT OF FLAG POLE.

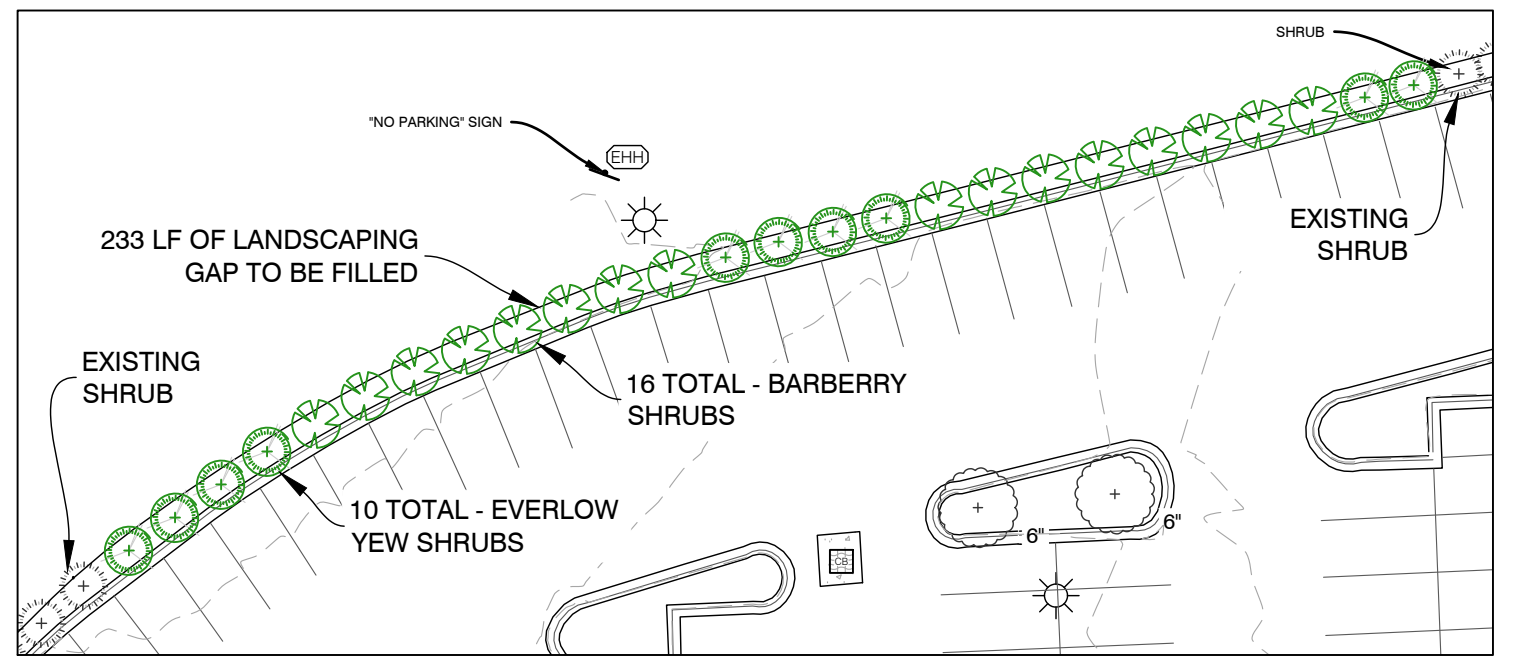
FLAGPOLE MOUNTING HEIGHT	A	B	C	D
20' - 0"	2' - 0"	2' - 6"	30"	24"
25' - 0"	2' - 6"	3' - 0"	36"	24"
30' - 0"	3' - 0"	3' - 6"	36"	24"
35' - 0"	3' - 6"	4' - 0"	36"	30"



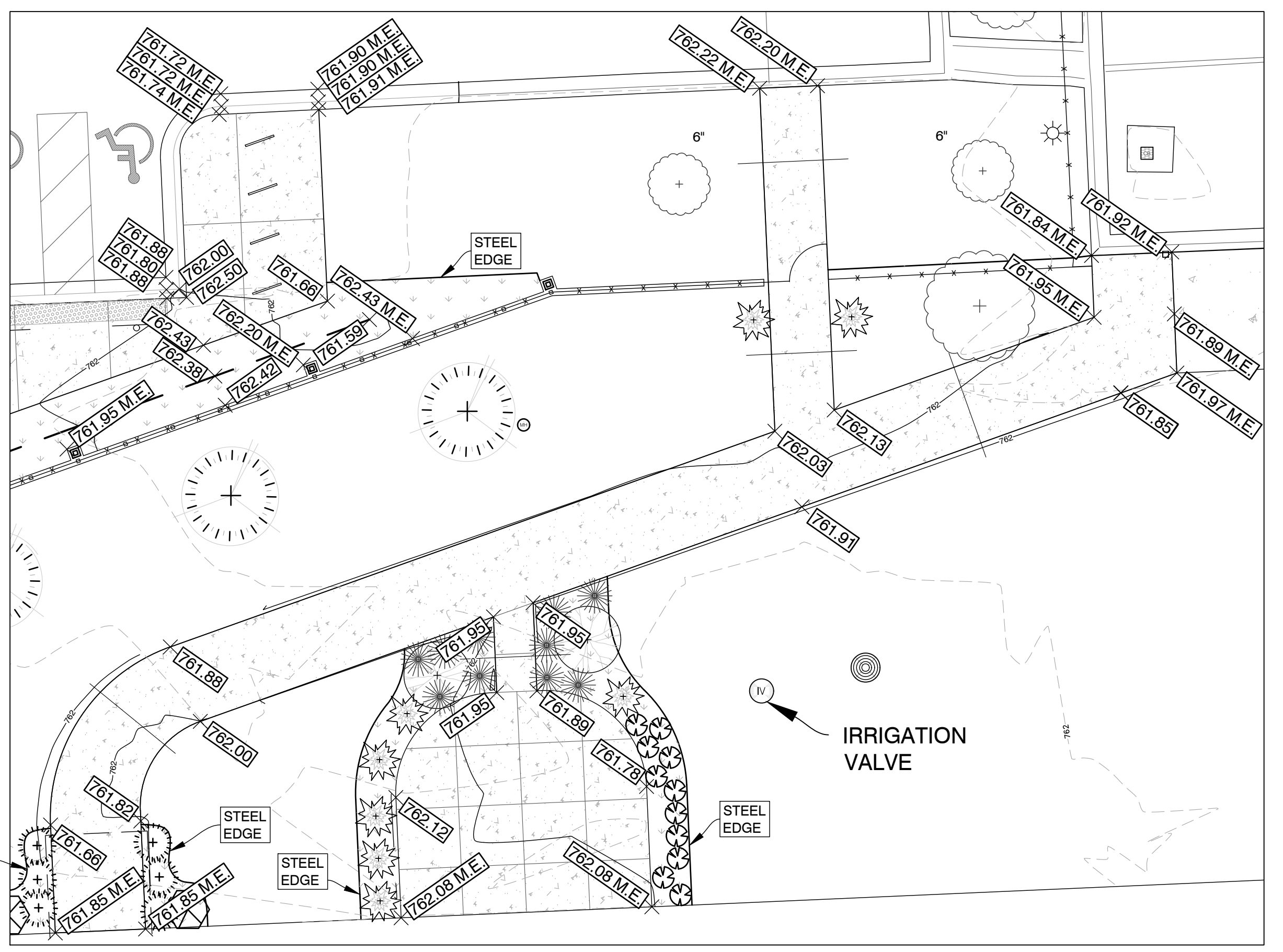
FLAG POLE DETAIL
C3.0 NOT TO SCALE



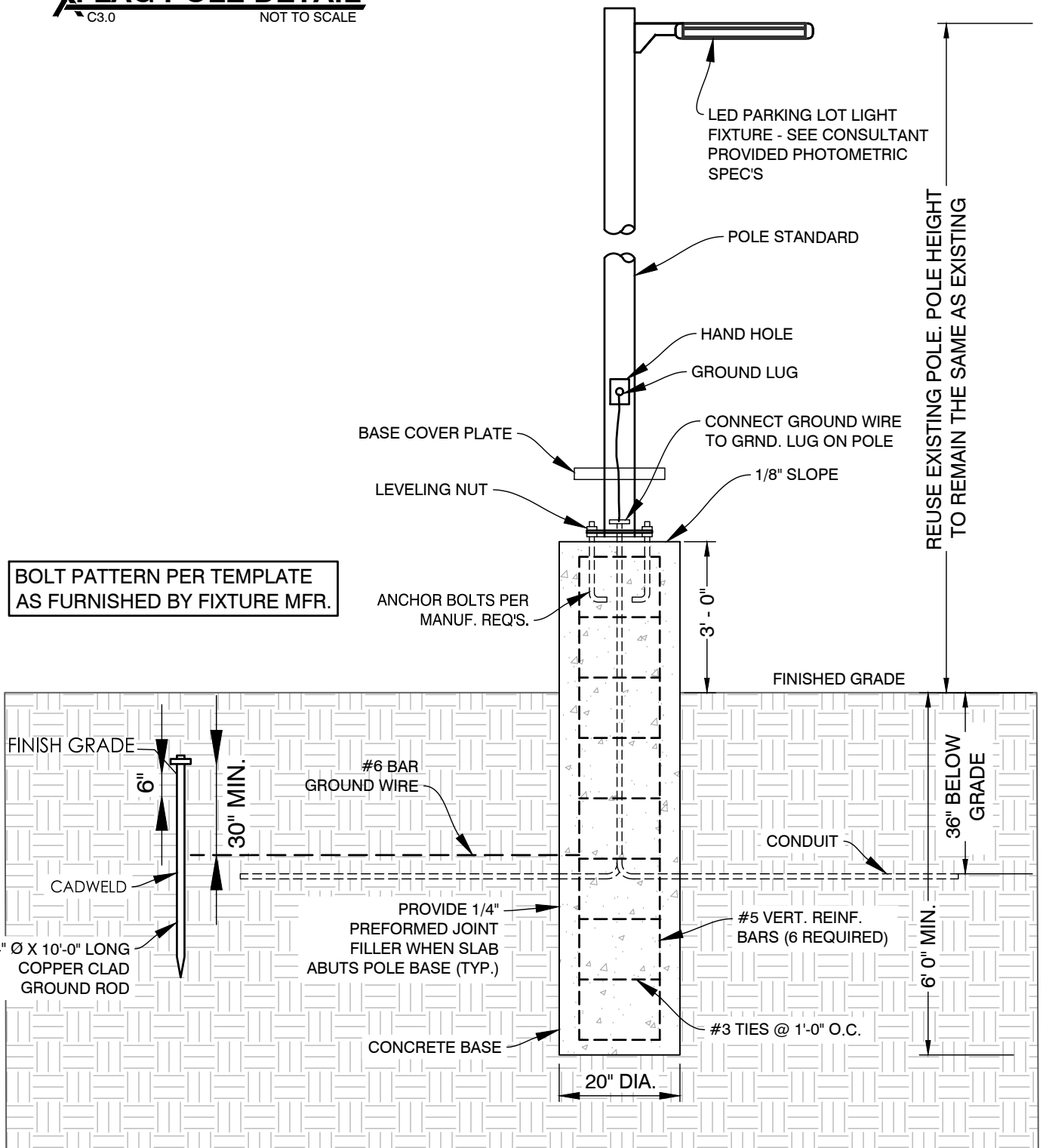
HANDICAP PARKING SIGN DETAIL
C3.0 NOT TO SCALE



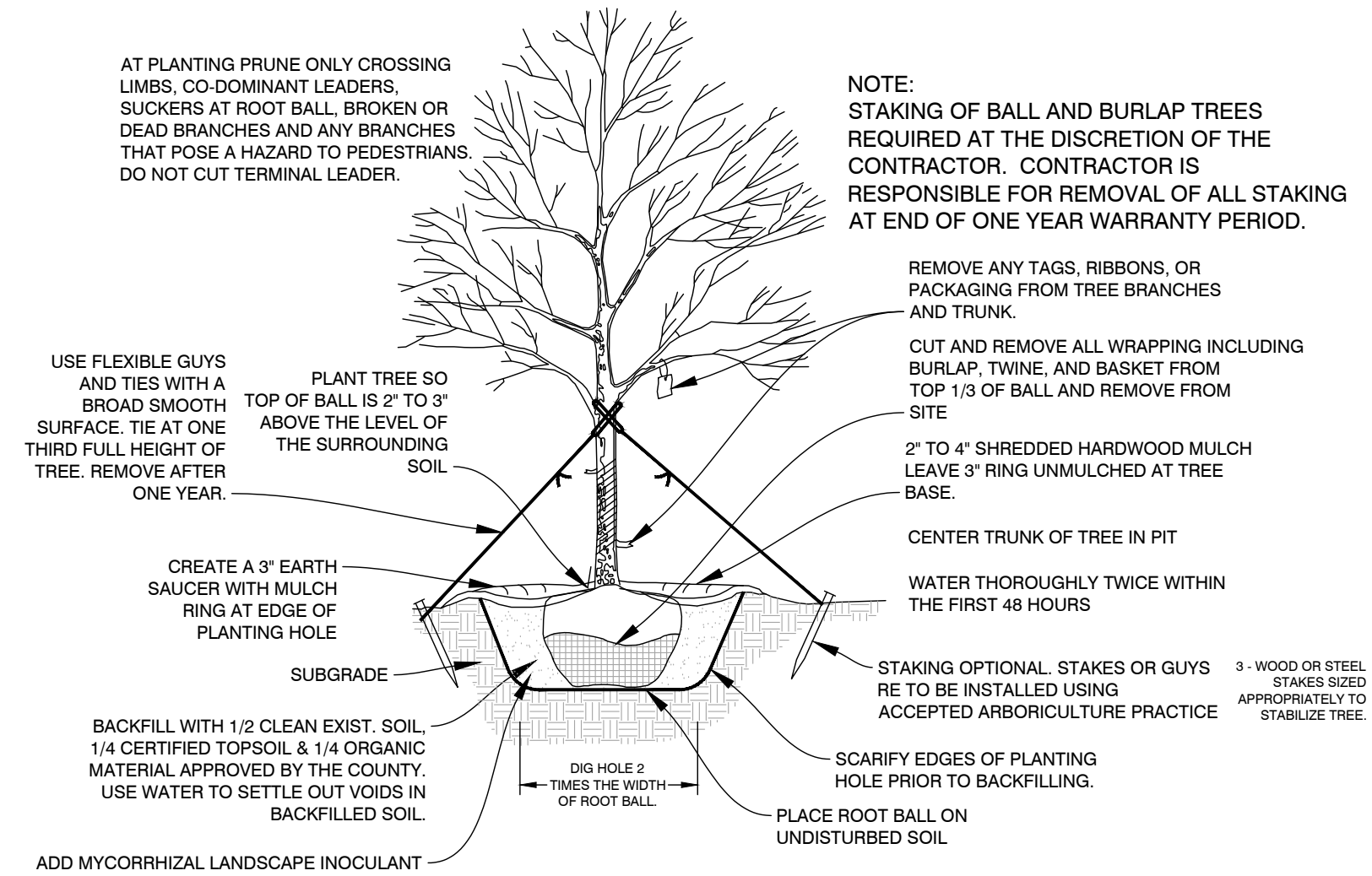
CROSSTOWN PKWY FRONTAGE LANDSCAPING DETAIL
C3.0 1 INCH = 30 FEET



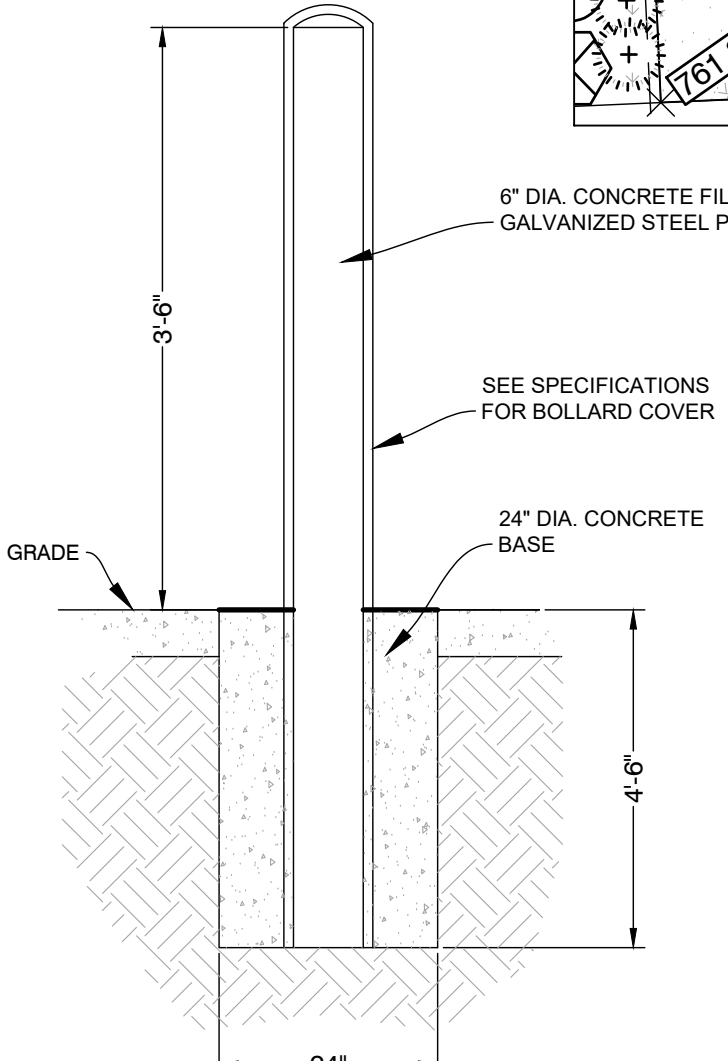
PATIO GRADING DETAIL
C3.0 1 INCH = 10 FEET



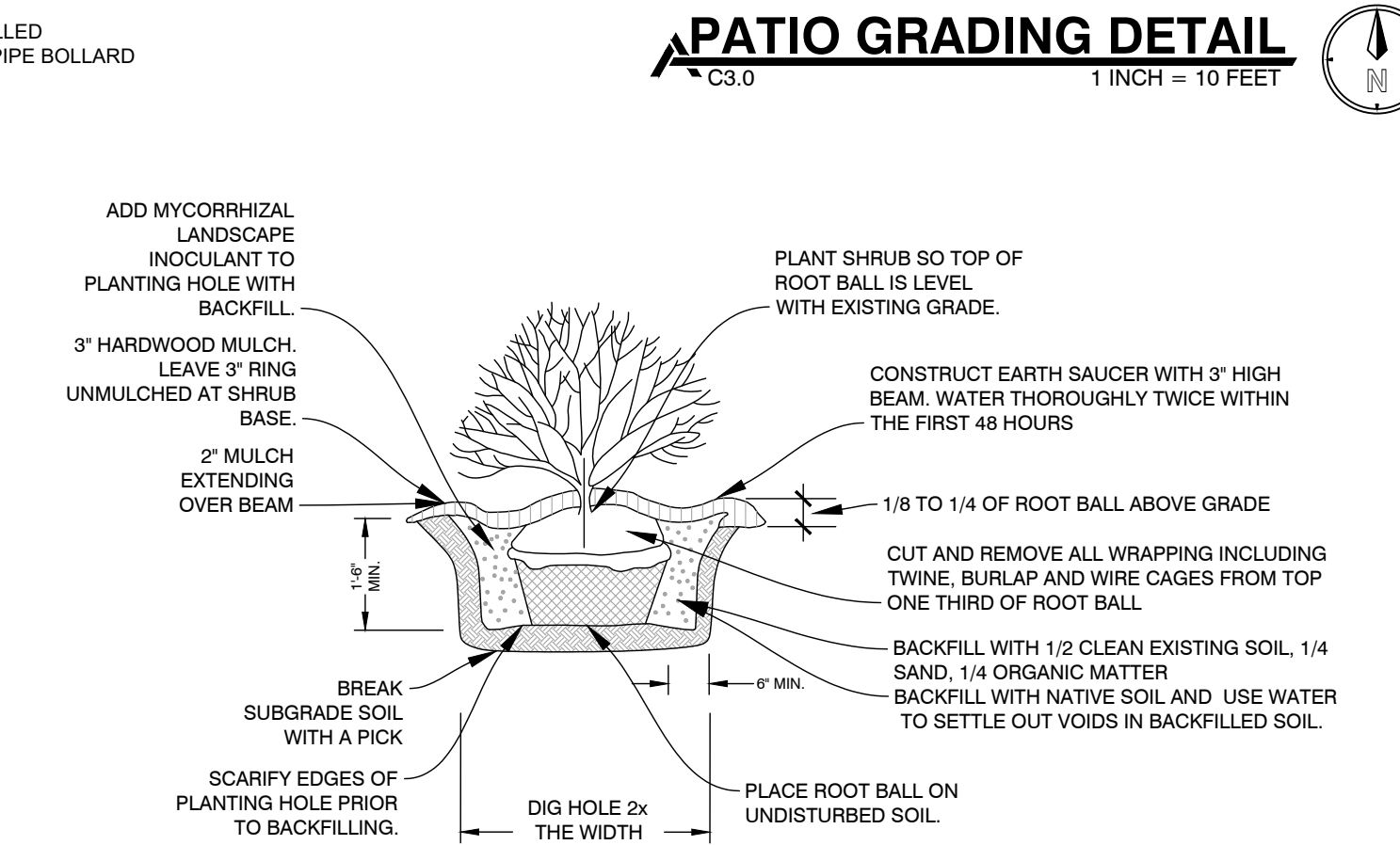
LIGHT POST DETAIL
C3.0 - 09/0110 NOT TO SCALE



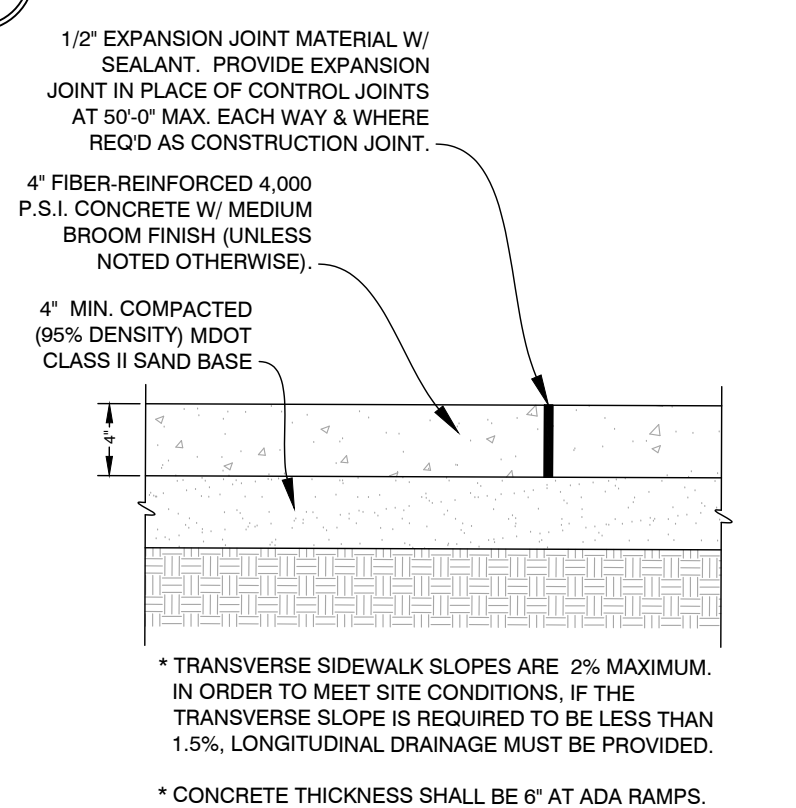
TYPICAL DECIDUOUS TREE PLANTING DETAIL
C3.0 NOT TO SCALE



6\"/>



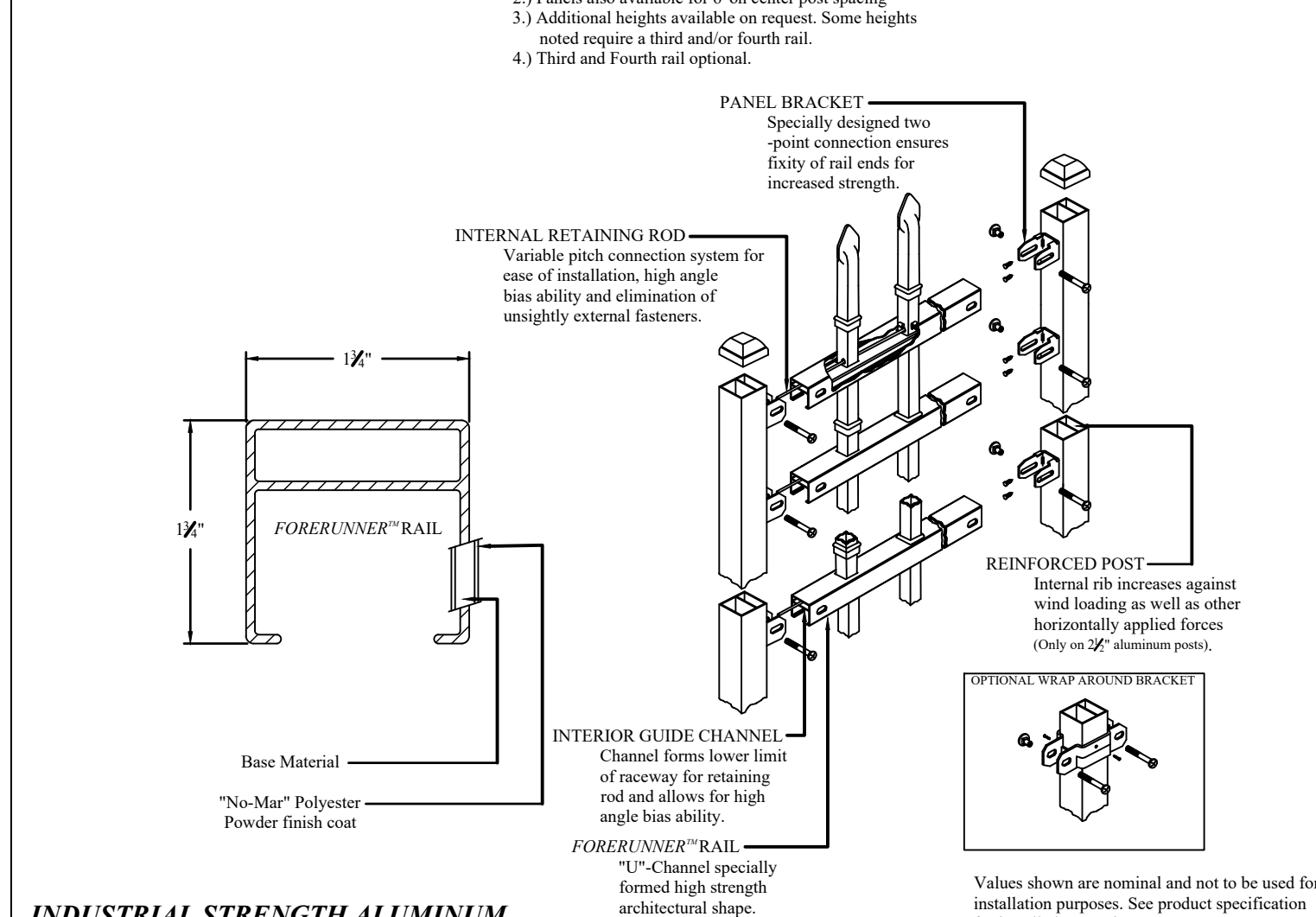
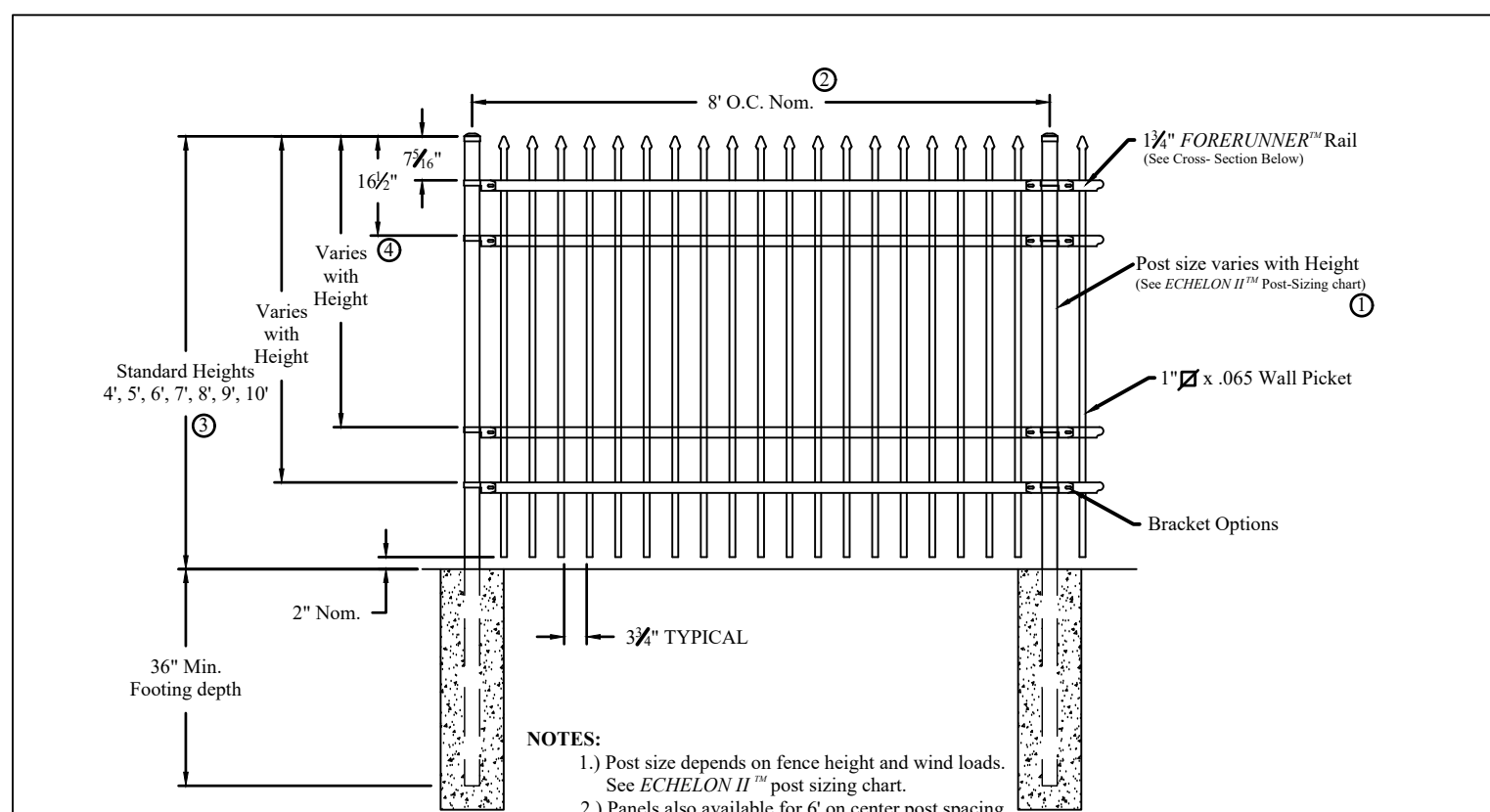
TYPICAL SHRUB PLANTING DETAIL
C3.0 NOT TO SCALE



CONCRETE WALK DETAIL
C3.0 NOT TO SCALE

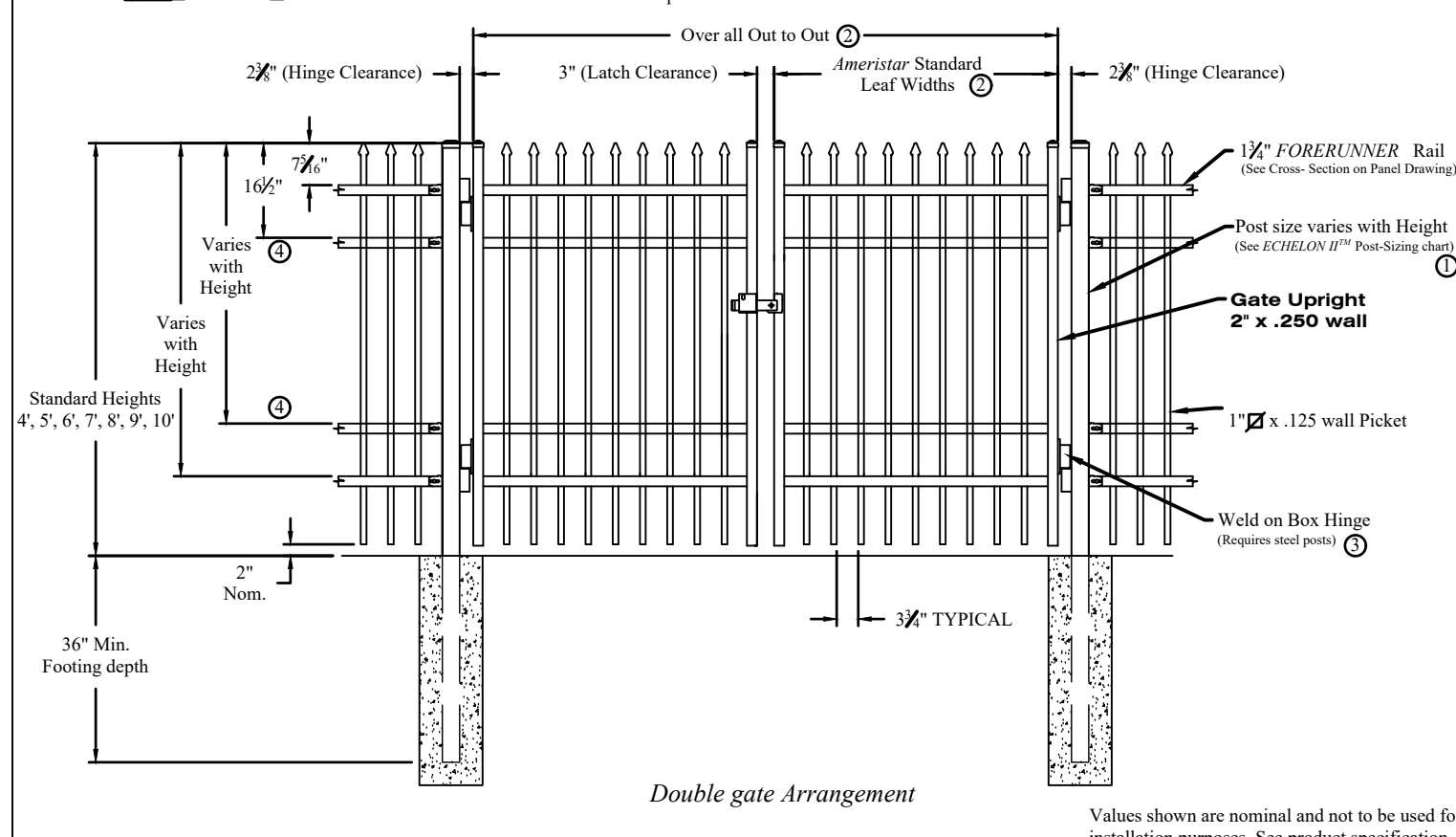
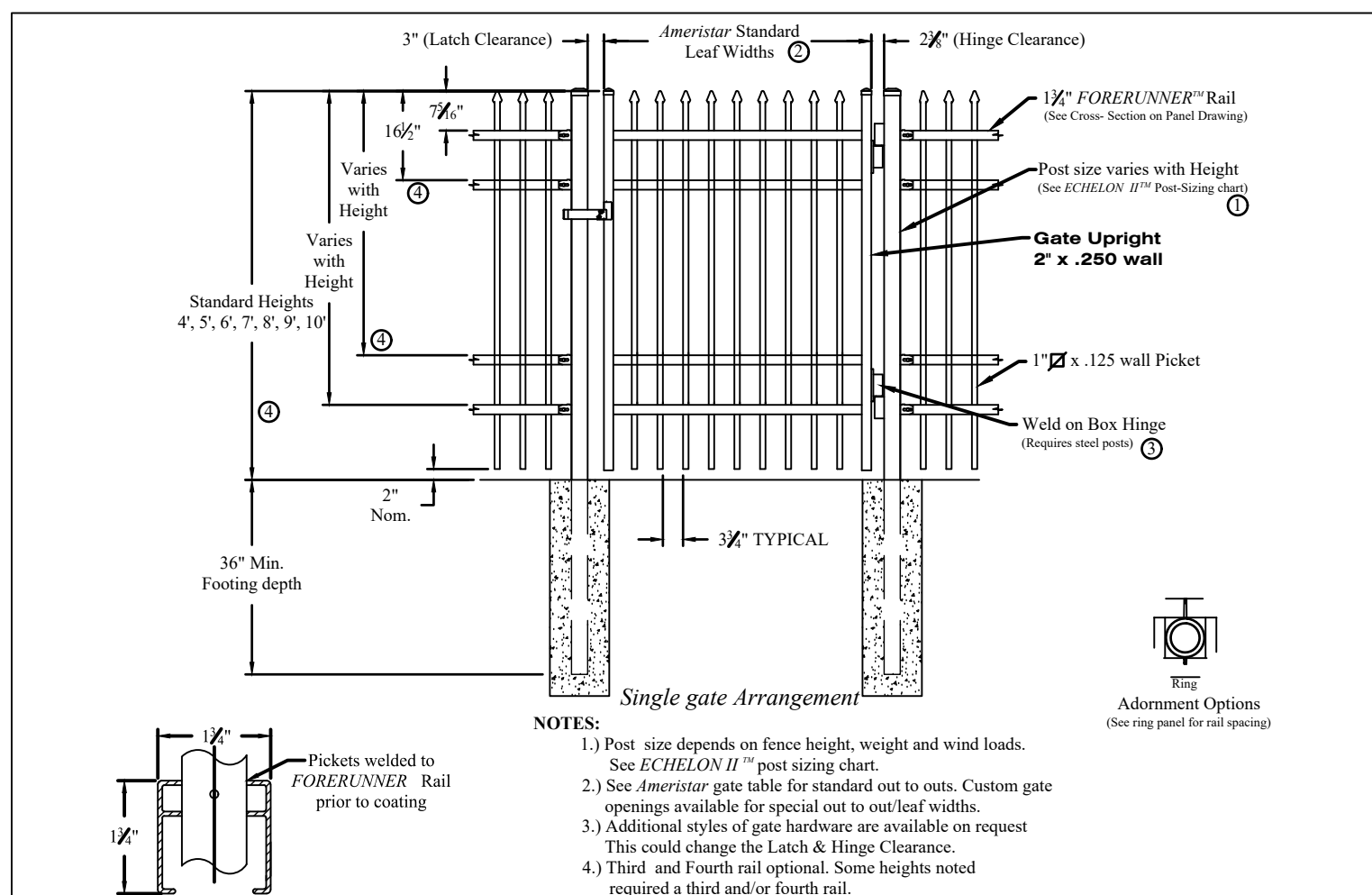
No.	ISSUED FOR:	DATE	BY:
0	CHECKLIST MEETING SUBMITTAL	07/31/2025	tc
1	BIDS/SITE PLAN SUBMITTAL	09/08/2025	tc
2			
3			
4			

REPRODUCTION, COPYING OR OTHER USE OF THIS DRAWING WITHOUT WRITTEN CONSENT IS PROHIBITED © AR ENGINEERING, 2025



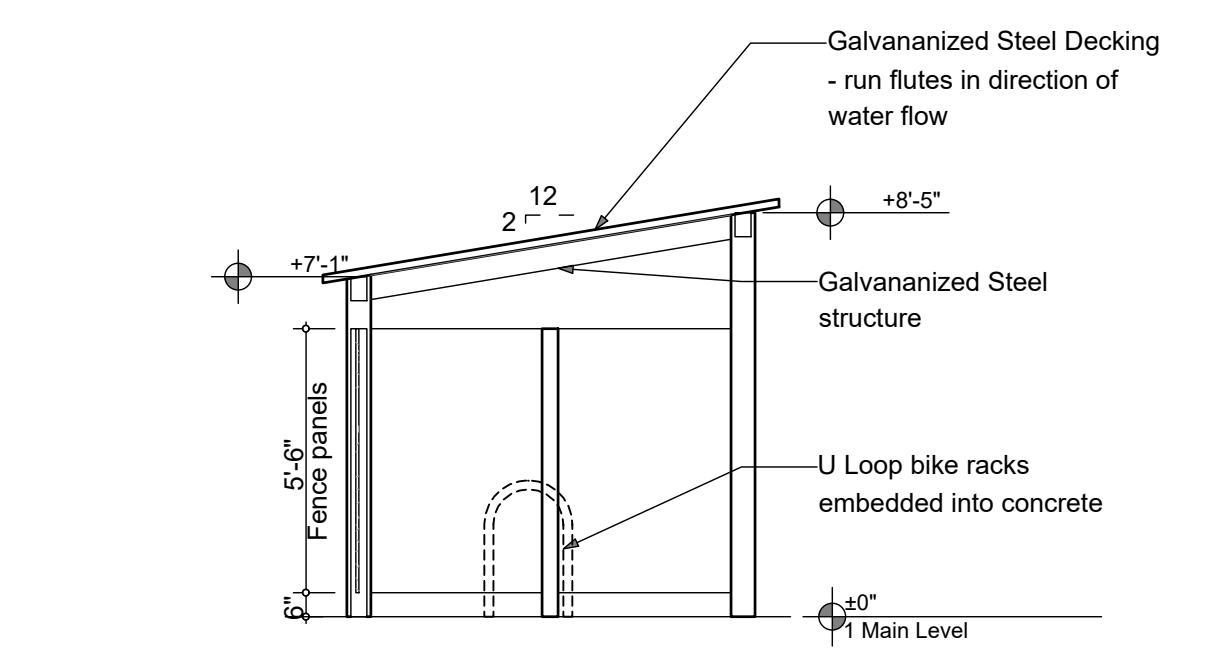
INDUSTRIAL STRENGTH ALUMINUM
ÉCHELON II CLASSIC 2 3/4-RAIL
 DR: NIB SH_1of1 SCALE: DO NOT SCALE
 CK: BS Date 2-07-12 REV: f

AMERISTAR®
 1555 N. Mingo
 Tulsa, OK 74116
 1-888-333-3422
 www.ameristarfence.com

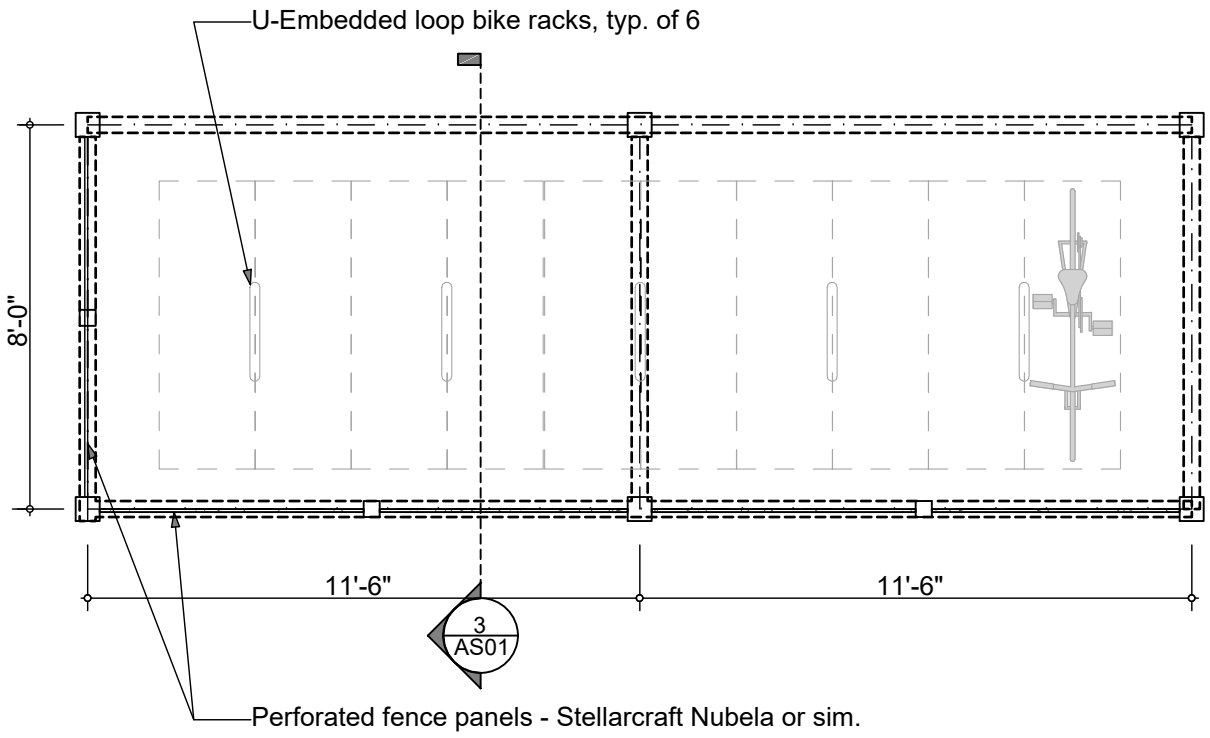


INDUSTRIAL STRENGTH ALUMINUM
ÉCHELON II CLASSIC 2 3/4-RAIL SGL & DBL GATE
 DR: NIB SH_1of1 SCALE: DO NOT SCALE
 CK: BS Date 2-7-12 REV: d

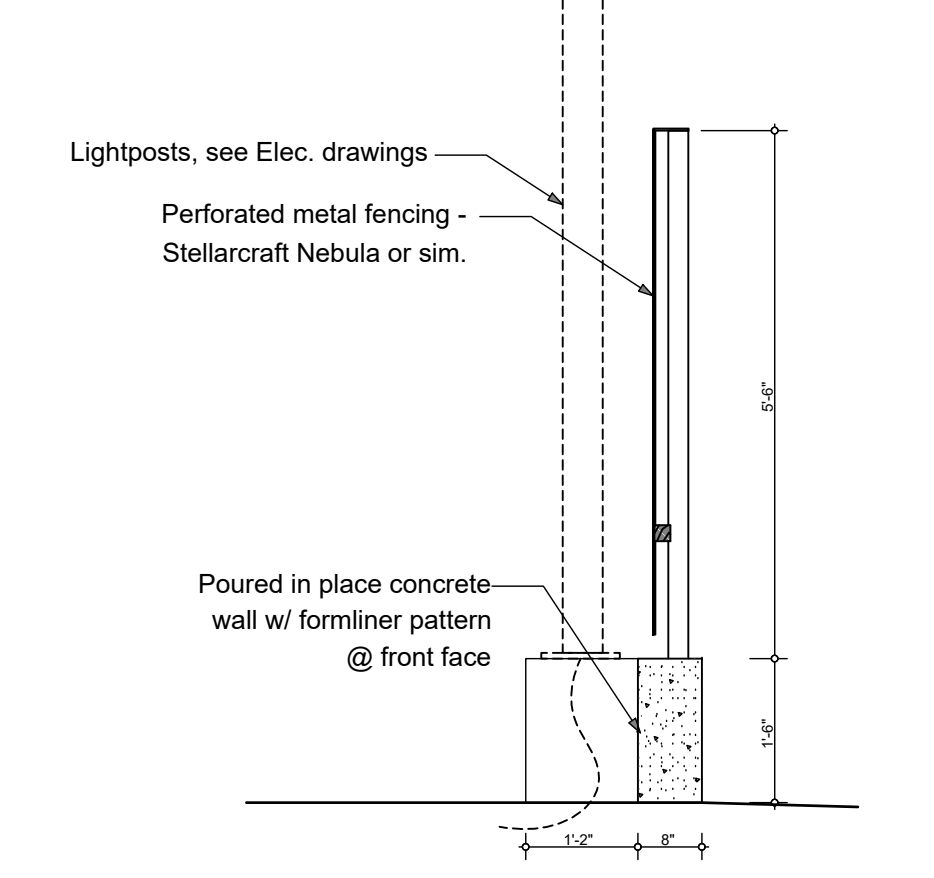
AMERISTAR®
 1555 N. Mingo
 Tulsa, OK 74116
 1-888-333-3422
 www.ameristarfence.com



BIKE SHELTER SECTION
 CS.1 NOT TO SCALE

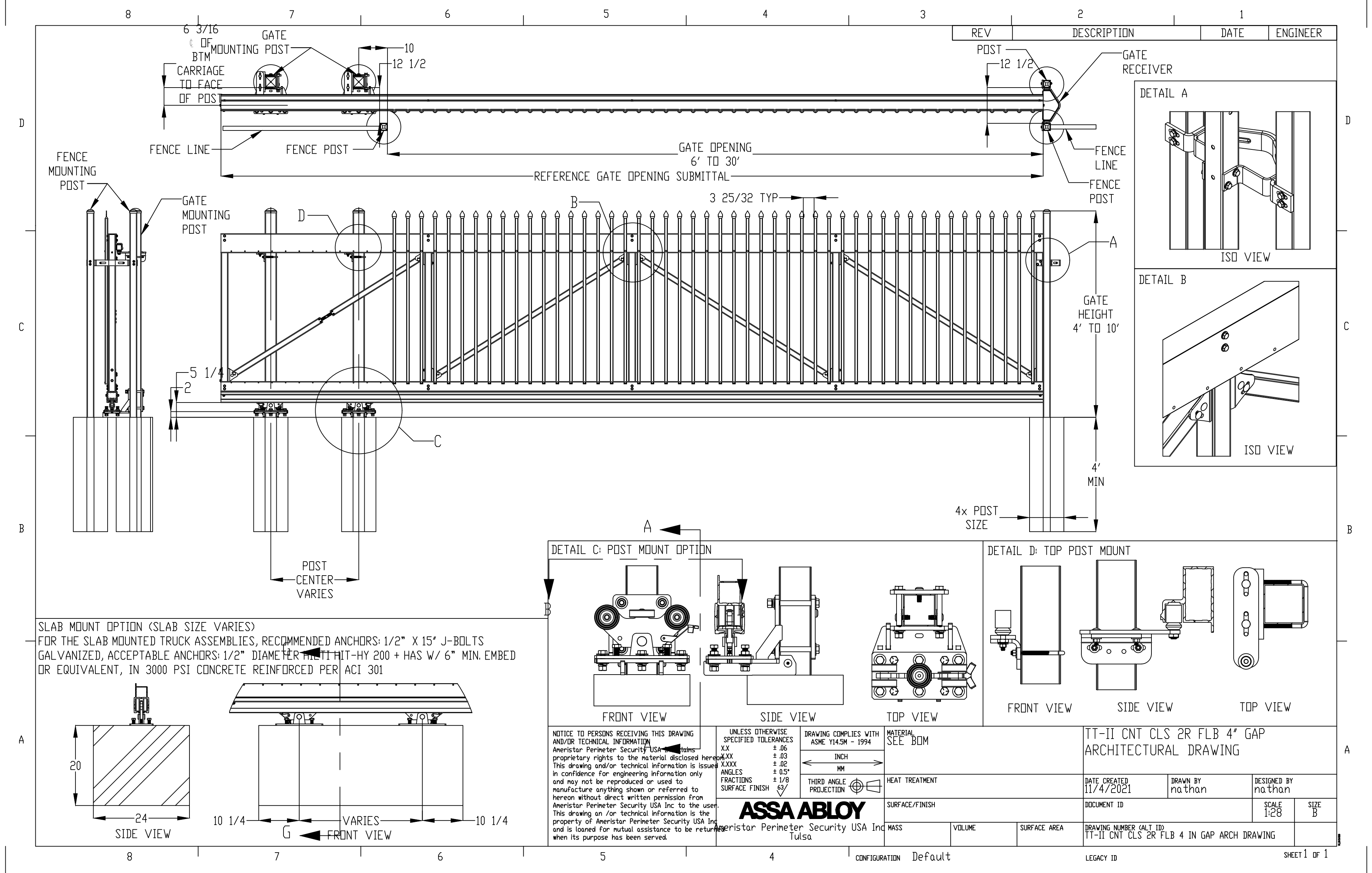


BIKE SHELTER ENLARGED PLAN
 CS.1 NOT TO SCALE



SITE WALL SECTION DETAIL
 CS.1 NOT TO SCALE

- GENERAL NOTES**
- DIMENSIONS TAKE PRECEDENCE OVER SCALE. CONTRACTOR TO VERIFY ALL DIMENSIONS IN FIELD.
 - IF ANY ERRORS, DISCREPANCIES, OR OMISSIONS BECOME APPARENT, THESE SHALL BE BROUGHT TO THE ATTENTION OF THE ARCHITECT/ENGINEER PRIOR TO CONSTRUCTION OF ANYTHING AFFECTED SO THAT CLARIFICATION OR REDESIGN MAY OCCUR.
 - ALL CURB RADI AND DIMENSIONS ARE TO FACE OF CURB. CURB TO BE PROVIDED WHERE SHOWN AND INTEGRAL WITH SIDEWALK AT PAVING EDGE.
 - SLOPE GRADES UNIFORMLY BETWEEN ELEVATIONS SHOWN. NOMINAL GRADING. SLOPE SIDEWALKS AWAY FROM BUILDING AT 1/4" PER FOOT ON ENTRY WALK.
 - ALL WORK SHALL CONFORM TO ALL LOCAL, STATE AND FEDERAL LAWS, RULES AND REGULATIONS IN FORCE AT TIME OF CONSTRUCTION.
 - REFER TO NOTES IN ARCHITECTURAL PLANS FOR ALL WORK RELATED TO ELECTRICAL, PLUMBING, AND MECHANICAL WORK, AS WELL AS ANY UTILITY WORK.
 - ALL WORK SHALL CONFORM TO THE MICHIGAN HANDICAPPED ACCESSIBILITY CODE AND THE AMERICANS WITH DISABILITIES ACT.
 - THE GENERAL CONTRACTOR SHALL BE RESPONSIBLE FOR OBTAINING ALL PERMITS, PERMIT COSTS, TAP FEES, METER DEPOSITS, PERMANENT UTILITY APPLICATIONS, BONDS, AND OTHER FEES REQUIRED FOR PROPOSED WORK. THIS SHALL INCLUDE, BUT SHALL NOT BE LIMITED TO THOSE REQUIRED BY THE CITY OF KALAMAZOO, KALAMAZOO COUNTY AND THE STATE OF MICHIGAN.
 - CONTACT MISS DIG '811' FOR LOCATION OF UNDERGROUND UTILITIES A MINIMUM OF 48 HOURS BEFORE COMMENCING EXCAVATION WORK. THIS DOES NOT RELIEVE THE CONTRACTOR OF THE RESPONSIBILITY OF NOTIFYING UTILITY OWNERS WHO ARE NOT PART OF THE 'MISS DIG' ALERT SYSTEM. THE CONTRACTOR SHALL CONDUCT HIS OPERATIONS IN A MANNER AS TO ENSURE THAT THOSE UTILITIES NOT REQUIRING RELOCATION WILL NOT BE DISTURBED.
 - ANY SANITARY SEWER, SANITARY SEWER SERVICE LEADS, WATER MAIN, WATER SERVICES, OR STORM SEWER WHICH IS DAMAGED BY THE CONTRACTOR DURING HIS OPERATIONS SHALL BE REPAIRED TO THE OWNERS SATISFACTION, AND AT THE CONTRACTORS EXPENSE. IF ANY UTILITIES ARE DAMAGED AND NEED REPAIRED IT, MUST MEET THE CITY OF KALAMAZOO/OWNERS SPECIFICATIONS.
 - THE ELECTRICAL CONTRACTOR IS RESPONSIBLE FOR THE ELECTRICAL TRANSFORMER PAD PER THE UTILITY COMPANY SPECIFICATIONS.
 - THE TELEPHONE UTILITY COMPANY SHALL PROVIDE UNDERGROUND TELEPHONE TO THE BUILDING AT THE OWNERS EXPENSE.
 - DESIGN, INSTALLATION AND SPECIFICATION FOR IMPROVEMENTS RELATED TO GAS, TELEPHONE, ELECTRIC AND CABLE TELEVISION SERVICES SHALL BE COORDINATED BY THE CONTRACTOR.
 - CONTRACTOR SHALL COORDINATE TELEPHONE, ELECTRIC, AND CABLE TELEVISION CONDUITS WITH THE APPROPRIATE UTILITY PRIOR TO PAVEMENT INSTALLATION.
 - CONTRACTOR IS TO UNCOVER AND CONFIRM ALL TAP LOCATIONS. LOCATION DISCREPANCIES ARE TO BE BROUGHT TO THE ENGINEERS ATTENTION FOR RESOLUTION.
 - DEMOLISH & REMOVE ALL EXISTING SITE FEATURES AS REQUIRED.
 - CONTRACTOR SHALL REVIEW THE GEOTECHNICAL REPORT PREPARED FOR THIS SITE.
 - ALL WATER, SANITARY, AND STORM STRUCTURES SHOWN AS SURVEYED. ALL PIPING RELATED TO THESE UTILITIES BASED ON CROSSTOWN CENTER PLANS DATED 11/30/2000. CONTRACTOR SHALL VERIFY & ALERT ENGINEER OF ANY DISCREPANCIES.
 - CONTRACTOR TO VERIFY LOCATION OF EXISTING UTILITIES PRIOR TO CONSTRUCTION. LOCATION DISCREPANCIES ARE TO BE BROUGHT TO THE ENGINEERS ATTENTION FOR RESOLUTION.
 - ALL WATER, SANITARY AND STORM UTILITIES ARE TO BE PROTECTED UNLESS OTHERWISE NOTED.
 - ANY SANITARY SEWER, SANITARY SEWER SERVICE LEADS, WATER MAIN, WATER SERVICES, OR STORM SEWER WHICH IS DAMAGED BY THE CONTRACTOR DURING HIS OPERATIONS SHALL BE REPAIRED TO THE OWNERS SATISFACTION, AND AT THE CONTRACTORS EXPENSE. IF ANY ELEMENTS OF THE SANITARY SEWER SYSTEM ARE DAMAGED AND NEED REPAIRED, IT MUST MEET THE CITY OF KALAMAZOO SPECIFICATIONS.
 - REFER TO ELECTRICAL DRAWINGS FOR UNDERGROUND ELECTRICAL REQUIREMENTS FOR SITE.
 - DESIGN, INSTALLATION AND SPECIFICATION FOR IMPROVEMENTS RELATED TO GAS, TELEPHONE, ELECTRIC AND CABLE TELEVISION SERVICES SHALL BE COORDINATED BY THE CONTRACTOR.



PLANS PREPARED BY:

 AR ENGINEERING
 CIVIL ENGINEERING & SURVEYING
 MICHIGAN | INDIANA | ILLINOIS | OHIO
 289.251.5911 PHONE | 888.563.0044 FAX
 www.arengeering.com

DRAWN: aw
 CHECKED: --

PRELIMINARY
 NOT FOR CONSTRUCTION

No.	ISSUED FOR:	DATE	BY
0	CHECKLIST MEETING SUBMITTAL	07/31/2025	tc
1	BIDS/SITE PLAN SUBMITTAL	09/08/2025	tc
2			
3			
4			

REPRODUCTION, COPYING OR OTHER USE OF THIS DRAWING WITHOUT WRITTEN CONSENT IS PROHIBITED BY AR ENGINEERING, 2025.

FENCING DETAILS
 CITY OF KALAMAZOO - CROSSTOWN FACILITY
 INTERSECT
 150 E CROSSTOWN PARKWAY, KALAMAZOO, MI 49001
 SECTION 22, T02S, R11W

PROJECT:
 CLIENT:
 SITE ADDRESS:
 SITE SECTION:

JOB NUMBER
24182004

DATE
09/08/2025

SHEET NUMBER
C3.1



ATTACHMENT 4

SCOPE

**Electrical & Data
Crosstown Parkway Remodel**

Bid Reference #: 91082-033.0

September 2025



BUILD SOMETHING BETTER.

City of Kalamazoo-Crosstown Facility

**Bid Package #1
Kalamazoo, MI
AVB-23-062**

FORM 00 24 00.1.4.26.100
(a.k.a. ATTACHMENT B - SCOPE OF WORK ALL TRADES)

Work Scope 26.100 Electrical

Specification Sections Included:

- AVB 00 0000 Bidders Instructions and Requirements**
- AVB 00 7200 General Workscope Requirements**
- AVB 01 0000 Subcontractor General Requirements**
- AVB 00 AVB Health & Safety Policy**

Reference Specification Sections:

0.0 Special Bidding Requirements:	
1	Bids must be submitted to City for sealed opening per bidders instructions.
1.0 Work Scope Notes:	
1	Submittal of a proposal and acceptance of a contract assumes this subcontractor has included all scope of work relative to this bid category and has accepted all terms and conditions identified in the bid documentation.
3	Subcontractor shall provide adequate manpower and equipment at all times, as required to meet the project schedule. Subcontractor shall provide labor as required to preserve workplace harmony and prevent any jobsite disruption.
4	Include warranty per the Owner's listed requirements from the substantial completion date for the entire project, not from the substantial completion of this portion of work. Where special warranties are specified, those longer warranty periods shall commence from substantial completion date for the entire project.

5	Bidder will get formal acceptance on any warranty shorter than any specification requirement or shorter than subcontractor warranty of two years through RFI process, recorded and distributed, or will bid as specified with voluntary alternate for savings of reduced warranty term.
6	Furnish all necessary taxes, bonds and insurance as per the Owner's listed requirements. A Certificate of Insurance from the Subcontractor's Insurance Carrier must be in AVB Construction's possession prior to start of work. AVB Construction and the Project Owner and any other parties listed in the contract shall be named as additional insured. A sample with specific verbiage and owner entities for additional insured will be provided.
7	Subcontractor shall furnish all means, methods, labor, material, equipment, layout, field measurements, permits, licenses, etc. which may be required to complete their scope of work.
8	Subcontractor will identify any sub-tiered subs on proposal, in SOV and in workplan. 3rd tier subs will be managed on site by a direct employee of the awarded subcontractor. The onsite management will be developed and approved at the discretion of the AVB superintendent, and may be adjusted by the AVB superintendent when deemed necessary to manage labor, safety, schedule, quality and site cleanliness.
9	Any materials with longer than 4 week lead times should be called out with their respective lead time in the bid.
10	All materials shall meet the requirements of the specifications, and shall be installed per manufacturer recommendations and specifications.
11	Subcontractor is responsible for review and knowledge of all drawings as related to this project. Any discrepancies in the drawings that will affect this subcontractor's scope of work shall be brought to CM's attention immediately.
12	Subcontractor will review all specifications within their work scope and submit product data, shop drawings, samples and other required submittals in packages by spec section for approval electronically; PDF documents are preferred. Unless otherwise noted, contractor will receive notification of submittals required through PROCORE and submit through PROCORE to those specs. Contractor should notify AVB if there are discrepancies in the submittal log received.
13	Subcontractor shall have full time supervision on the jobsite at all times that is knowledgeable and competent in the detailed requirements of the work of this subsystem. This person shall not be removed from this project until the work is complete and shall not be removed or replaced without the approval of the AVB Project Manager. Subcontractors are responsible for assigning a designated English speaking foreman. It is the responsibility of the subcontractor to translate the site specific safety orientation, updates, and any other communications from AVB. Lack of understanding of the English language is NOT a valid reason for violating ANY safety rules or required AVB procedures.
14	Subcontractor to participate in pre-installation meetings.
15	Subcontractor will participate in on-site Progress Meetings starting 2 weeks prior to their trades work and continuing 2 weeks beyond completion of their trades work. Additional meetings may be required to coordinate trades and will be attended by trades at the AVB team discretion. AVB superintendent may grant requests to attend virtually or miss a meeting, if received at least 2 days prior to meeting.

16	Subcontractor must coordinate its work with the work of other subcontractors at the site to eliminate conflicts. No additional costs as a result of a lack of coordination will be allowed.
17	Subcontractor is to include all unloading and protection of materials delivered to site including all necessary machinery for material handling. This includes all staging and movement to final placing. This subcontractor to coordinate the location of stored materials with CM and provide relocation if necessary.
18	Subcontractor shall inspect the area of work to insure that surfaces are ready for installation. Subcontractor to bring to the attention of the AVB Construction Superintendent or Project Manager any problems with the surfaces. Proceeding with the work constitutes acceptance of a surface.
19	Clean up and removal of debris from construction area to appropriate project dumpster shall be performed by this subcontractor as it applies to their scope of work on a DAILY basis. Additional clean up may be required to maintain clear egress and a safe worksite, at the discretion of the AVB Construction Superintendent. Failure to clean up shall be cause for this work to be performed by others at the expense of this subcontractor.
20	Clean existing streets and parking areas of all dirt and debris as generated by your work force on a daily and as-needed basis, or as directed by the CM.
21	If, after prior written request, this subcontractor has not cleaned loose debris, materials, and general garbage to satisfaction of AVB Superintendent, AVB will perform the necessary cleaning at a rate of 10% higher than the subcontractors highest labor rate of the offending subcontractor. For example, if the foreman is listed at \$80/hr., AVBs hourly rate for cleanup will be \$88/hr.
22	Provide multiple mobilizations, at no additional cost, as required to maintain construction progress and as directed by AVB.
2.0 Safety:	
1	All work is to comply with all federal, state, and local codes and ordinances, including OSHA, MIOSHA and the AVB Safety Program. AVB Safety Program is included in bidding documents. AVB Supervisory Personnel may issue deviation tickets and impose monetary fines and/or withhold from the subcontractors next progress payment for non-compliance with safety and health requirements.
2	Notify Miss Dig and/or all appropriate utility companies before start of work and locate all existing utilities.
3	All scaffolding and temporary handrails are to comply with OSHA guidelines. Provide and install all necessary bracing, signage, and protection as directed by OSHA and/or AVB guidelines. Daily inspections/tagging are required for the entire duration of the erected scaffold.
4	Subcontractor to provide and comply with written silica dust control plan for all activities creating potential hazard.
5	Subcontractor will implement a project specific safety program and shall participate in site safety program including, but not limited to: site safety orientations, daily foreman review with superintendent and site specific trainings and meetings.

6	It is the responsibility of each trade to provide, maintain and train workers within that trade on Safety Data Sheets related to any materials used by this trade on site.
7	Jobsite safety per OSHA and AVB Safety plans is required. AVB can issue safety deviation tickets and fine the company of any employee not adhering to required safety measures.
8	Subcontractor shall have at least one first aid certified crew member on site at all times. Subcontractor will provide first aid certification cards at the onsite safety orientation as requested.
9	Subcontractor will submit subcontractor safety manual, field workers first aid certificates, other respective trainings, equipment certifications, and safety data sheets as PROCORE Submittals (01 3500-01 Safety Manual, 01 3500-02 Certifications, 01 3500-03 SDS)
3.0 Schedule:	
1	Please note that although the schedule defines the planned order of construction, Bidders should not assume any assurance is given or implied as to the calendar dates associated with completion of the work of a particular contract.
2	All Contractors and Subcontractor recognize and shall accept modifications to the schedule which are reasonable, in the opinion of the Construction Manager, for the general interest of the project as a result of allowable time extensions in any contract, and such modifications are inherent to the construction process and shall not qualify as a basis for extra compensation from the Construction Manager or Owner.
3	The Contractor, in submitting a proposal for the work of a particular work category, agrees to commit the necessary resources to complete the work activities of that work category, within a time span not greater than the duration given on the Bid Document Construction Schedule.
4	Bidder to provide detailed work plan, including amount of dedicated, on-site manpower for any tasks identified in Bid Schedule. Provide similar information with expected duration breakdown of any Subtasks not specifically identified in Bid Schedule but is required to complete scope of work. Additional information may be requested upon review by AVB Project Manager. This detailed work plan to be provided with Bid Form for review prior to bid opening.
5	Progress punch lists will be scheduled and performed. Contractors will attend and participate in any progress punch lists scheduled at least 4 weeks prior.
6	Any overrun of the duration for this Contractor given in the Bid Document Construction Schedule that will require overtime, unplanned measures, or other consequences of delay that must be instituted by subsequent Contractors to avoid extension of the scheduled end date and associated liquidated damages will be the financial burden of this Contractor.
7	AVB Construction reserves the right to retain additional labor forces to complete this scope of work if it is deemed the construction schedule is not being met. This additional manpower will be the financial responsibility of this Contractor.
4.0 Accounting:	
1	Costs associated with document printing and CAD files (or equivalent) are the Subcontractors responsibility.
2	Take note of Time, Material and Performance provisions as noted in the General Requirements.
3	Include in proposal: labor rates and mark-ups for add's/extras/change orders.
4	Provide Schedule of Values to Project Manager with proposal. Schedule of values should show labor and material costs for each item.

5.0 Closeout:	
1	All subcontractors will provide warranty per the Owner's listed requirements from substantial completion for their scope of work.
2	Payments may be held at the 50% mark or beyond of billing completion until specification-required Operation and Maintenance information and other close-out information is provided up to as-built and final warranty documentation until all required closeout Operations and Maintenance Manuals and specification listed closeout requirements are met for approved materials, including submission of sample warranties for those items.
3	Operations and maintenance manuals, extra/maintenance materials and special warranties as required by the specifications are to be submitted in a timely manner. If at closeout time, special warranties do not meet the terms of the specification, the subcontractor will supply, on their own letterhead, a warranty that their company will cover the specification terms. Release of retention is contingent upon work completion, receipt of closeout documents, sworn statements and waivers.
4	Project will have progress and final punch performed by project team members, bidders are to plan to address these within 3 days to keep the project moving.
5	Formal cost requests for any field added work during punch time is to be submitted within 7 days of completion of the added work.
6	All subcontractors must provide a color electronic copy of their as-builts as part of closeout. Subcontractors who do not provide electronic copy can be backcharged for the documentation fees incurred.
6.0 Trade Specific:	
1	Furnish and install all labor, material, and equipment as required to complete the electrical system, including but not limited to lighting fixtures, devices, switchgear, panels, conduits, wiring, and a complete lighting control system (dimming panels, occupancy sensors, vacancy detector, daylight sensors, relay panels, and associated devices) as required by drawings and energy code.
2	Furnish and install a complete data and communications cabling system including all horizontal and backbone cabling, patch panels, termination hardware, racks, enclosures, jacks, faceplates, labeling, testing, certification, and all raceways/routing required for a fully operational system. Subcontractor shall prepare all necessary shop drawings/coordination plans, perform testing and certification of all cabling. Provide as a separate line item for bid comparison purposes.
3	Remove all existing cabling in demo areas back to closets, reset numbering to align with new system, and provide neat reinstallation consistent with Owner standards.
4	Furnish and install Cat6 plenum-rated cabling (blue) with 15' service loops at each end. Terminate with Panduit Mini-Com patch jacks and patch panels, consistent with existing Crosstown standards. Use angled jack wall plates to minimize bends at workstations. All drops shall terminate back to designated IT closets (#104, #160, #325) or new switch rooms (East side, confirm with Owner). Room #333 houses access/security panels — coordinate accordingly.

5	Furnish and install Panduit Mini-Com patch panels in closets with consistent numbering and labeling. Follow format [Closet]-[Faceplate #]-[Drop Letter], e.g., D-123-A/B/C. Patch panels must also list room numbers where faceplates are located. Provide labeling and documentation at completion. Endpoint and switch patch cords provided by Owner.
6	Provide triplex network interfaces in Rooms 153, 156, and 339 to support multiple VLANs. Install HDMI cabling from conference room TVs to table locations for presentations. Provide power/network ports behind TVs in coordination with Owner for size and placement.
7	Install a new fiber drop between Room 160 and IT Office Room 157; coordinate routing and termination with Owner. Provide and terminate cabling for all Wireless Access Points (WAPs) and cameras — drops to terminate in jacks, not plugs, with patch cables used for device connection.
8	Furnish and install a complete fire alarm system as indicated in the project documents, including relocation of the existing Simplex Panel and providing relays, smoke detectors, alarms, tamper switches, bells, annunciating devices, etc., as required for a complete operating system. Fire alarm system in areas not being renovated shall remain active.
9	Relocate existing 30' light pole(s) as shown on site drawings, including removal, reinstallation, new foundations/bases as required, reconnection to power, and coordination with site utilities.
10	Include supply and installation of New Police Emergency Phone on decorative lightpost
11	Furnish and install temporary power and temporary lighting for use of all trades throughout the building. Temporary Power & Lighting are to be provided so as to maintain a safe working environment for all trades, and as required by AVB safety policies & OSHA requirements.
12	Furnish and install all emergency and egress lighting, exit signs, and associated emergency circuits as required by code and project documents. Include connection to generator/transfer switch systems if indicated.
13	Furnish and install all site and exterior electrical work including exterior lighting, power to signage, bollards, EV charging stations, landscape lighting, gates and other site-mounted devices as indicated in the drawings.
14	Furnish and install all site and exterior lighting as indicated on the electrical drawings, including light poles with concrete bases, LED bollards, wall sconces, landscape/flood lights, canopy/entrance downlights, associated wiring, raceways, controls, and coordination with site and relevant trades.
15	Perform all electrical demolition per the Electrical Demo Plans and in coordination with Architectural Demolition Drawings.
16	Remove existing lighting fixtures, devices, conduits, boxes, and wiring back to source or nearest point of common use; dispose of all debris properly.
17	Maintain and protect active power/data wiring and conduit feeding spaces to remain or to be reused; clearly identify such runs to prevent damage.
18	Remove equipment and cabling systems no longer required, label unused breakers as "SPARE," and deliver salvaged equipment identified by Owner
19	All materials and workmanship shall conform to all applicable Code requirements, and the requirements of the local, state and federal authorities having jurisdiction.

20	This subcontractor shall pay for all permit and inspection fees for the work in this subsystem. Schedule and attend all required city, county and state inspections. Coordinate all inspection with the Project Superintendent to maintain a continuous sequence of work.
21	Contractor shall coordinate their work with work by all other trades. Contractor shall attend coordination meeting for equipment installed by other trades requiring electrical service. All interference/conflicts will be resolved as part of the base contract bid amount.
22	Contractor to include connecting to existing power, lighting, fire alarm circuits as indicated in the project documents, this includes time for information gathering of existing system as base bid.
23	Firestop all fire rated wall and floor penetrations which may occur as a result of work installed by this trade. Firestopping must be installed per UL listing for each respective product.
24	Provide access panels required for access to work installed by this trade. Access panels are to be installed by others.
25	Furnish and install all necessary coring, cutting and patching of walls, ceilings, and floors, where required for installations of materials by this trade.
26	Furnish and install starters, VFD's, and disconnects for mechanical equipment.
27	Furnish and install cabinet unit heaters with all accessories for a full functional system, as indicated on the electrical plans.
28	All low-voltage rough-ins, conduits, sleeves, raceways, boxes etc. are furnished and installed by this subcontractor. Devices for AV, security and access control shall be furnished and installed by others, but this subcontractor shall coordinate rough-ins to support those systems.
29	Provide all wiring, disconnects, switches, etc. for all mechanical and plumbing equipment .
30	Complete final electrical connections to all owner provided equipment and specialty systems as per project documents.
31	Provide and install conduit and boxes for HVAC thermostat devices. thermostat to be supplied by others. Coordinate location with HVAC subcontractor and drawings.
32	Furnish and install all control wiring and interlocks between electrical equipment and mechanical systems, in coordination with Mechanical subcontractor, for a complete and operational system.
33	Contractor shall provide all testing, commissioning, and certifications required for a complete system, including testing, lighting control system commissioning, fire alarm testing with AHJ, and data cable certification. Infrared scan of electrical panels, as-built drawings, O&M manuals, warranties, and Owner training shall be provided at closeout. Final payment may be held until such documents are received by AVB.
34	Furnish and install all pedestals, bollards, or mounting posts required for access control devices at doors, and other designated locations. Coordinate placement, conduit stub-ups, and rough-ins with Low Voltage/Access Control subcontractors (access control devices by others).
35	Furnish and install Knox Gate Key Switches at both CPED parking doors, including all wiring and connections to the gate access control system. Coordinate installation and integration with the Access Control subcontractor to ensure a fully operational system.
36	Include supply and installation of Horn and strobe above the existng FDCs, including all the conduits, wiring and devices.
37	Include measure as indicated in foundation notes on Sheet S100 for under structural slab piping and penetrations.

38	Include an allowance of \$10,000 for unforeseen existing conditions. This allowance shall be used only at the approval of the Construction Manager. Any portion of this allowance not authorized for use shall be credited back in full to the Owner at project closeout.
39	Subcontractor shall account for the project being completed in two phases: CPED first, followed by KDPS. Include multiple mobilizations, demobilizations, and remobilizations as required by the phasing plan and as directed by AVB.

Network Cabling Requirements

- **Cable Type:**
 - Cat6 plenum, blue
- **Termination Hardware:**
 - Panduit Minicom patch jacks on both ends
 - Continue using Panduit Mini-Com patch panels, consistent with existing Crosstown installations
 - Endpoint and switch patch cables to be provided by the owner
 - 15-foot service loop at each end
- **Patch Panel Labeling:**
 - Use consistent drop numbering format: [Networking Closet]-[Drop Faceplate #]-[Individual Drop Letter]
 - Example: D-123-A, D-123-B, D-123-C (three cables at faceplate 123 going to closet D)
 - Patch panels in network closets should note the room number where each faceplate is located
- **Demolition Phase:**
 - Remove existing network drops back to the closets in cleared areas
 - Reset drop numbering as part of cleanup and reinstallation
- **Wall Plates:**
 - Use *angled* jack wall plates to minimize cable bends near furniture

- **Conference Rooms:**
 - HDMI drop from TV to conference table for presentations
 - Power and network ports should be located behind the mounted TV panel, coordinate with owner for TV size & placement.
- **IT Office & 2nd Floor Broadcasting Room:**
 - Each network drop in Rooms 153, 156 & 339 must have triplex network interface (to support multiple VLANs).
- **Fiber Connectivity:**
 - A fiber drop is required from Room 160 to the IT office Room 157. Coordinate with Owner for location of drop.
- **Wireless Access Points (WAPs) & Cameras:**
 - Network cables to be available in their immediate vicinity
 - AP and camera network drops should terminate in jacks, not plugs, Devices then use patch cables for the final length.
- **Network Drop Head-Ends:**
 - All drops terminate back to existing IT Closets #104, #160, #325. Room #333 houses access control and security control panels.
 - Additional switch rooms will be located on the East side of the facility. Coordinate with owner to confirm location.

Work Scope 26.100 Electrical