



Department of Management Services
Purchasing Division
241 West South Street
Kalamazoo, MI 49007-4796
Phone: 269.337.8020
www.kalamazoo.org
cokpurchasing@kalamazoo.org

MANDATORY PRE-BID MEETING – Tuesday, June 10th, 2025 @ 9:00 a.m.
Location: Stockbridge Facility, Main Conference Room, 415 E Stockbridge, Kalamazoo, MI 49001

INVITATION FOR BID (IFB)

The City of Kalamazoo, Michigan is soliciting sealed bids for:

PROJECT NAME: Born Court Well 1-7

BID REFERENCE #: 91244-044.0

IFB ISSUE DATE: May 30, 2025

BID DUE/OPENING DATE: June 18, 2025 @ 3:00 p.m. Local Time
Electronic Bids Will Not Be Accepted.

MAILING ADDRESS & INSTRUCTIONS

Mail to:

Purchasing Division
241 W. South Street
Kalamazoo, MI 49007

Questions about this IFB should be directed to:
Department Contact: Anna Crandall, P.E.,
Asst City Engineer-Water Resources
at crandalla@kalamazoo.org

Include on the Envelope the Project Name and Bid Reference Number. All Envelopes Must Be Sealed.

You are invited to submit a bid for this project. Specifications, terms, conditions and instructions for submitting bids are contained herein. This Invitation for Bid with all pages, documents and attachments contained herein, or subsequently added to and made a part hereof, submitted as a fully and properly executed bid shall constitute the contract between the City and the successful bidder when approved and accepted on behalf of the City by an authorized official or agent of the City. Please review the bid document as soon as possible and note the **DEADLINE FOR QUESTIONS** in the Instructions to Bidders.

All bidders shall complete and return the Bid and Award page(s) and submit all information requested herein in order for a bid to be responsive. The bid document shall be returned in its entirety, in a properly identified and sealed envelope to the Purchasing Division at the above address. **BIDS MUST BE RECEIVED BEFORE THE DUE DATE - LATE BIDS WILL NOT BE CONSIDERED.** The City reserves the right to postpone the bid opening for its own convenience.

TABLE OF CONTENTS

<u>SECTION</u>	<u>PAGE #</u>	<u>APPENDICES</u>
		Appendix A
I	1 - 2	Appendix B
II	3 - 10	Prevailing Wages
III	11 - 12	Specifications
IV	13 - 14	Plans
V	15 - 21	
VI	22 - 27	

CITY OF KALAMAZOO – INVITATION FOR BIDS

Born Court Well 1-7

Bid Reference #: 91244-044.0

STATEMENT OF NO BID

NOTE: If you DO NOT intend to bid on this commodity or service, please complete and return this form immediately. Your response will assist us in evaluating all responses for this important project and to improve our bid solicitation process.

The Purchasing Division of the City of Kalamazoo wishes to keep its bidders list file up-to-date. If, for any reason you cannot supply the commodity/service noted in this bid solicitation, this form must be completed and returned to remain on the particular bid list for future projects of this type.

If you do not respond to this inquiry within the time set for the bid opening date and time noted, we will assume that you can no longer supply this commodity/service, and your name will be removed from this bid list.

_____ Specifications too "tight", i.e. geared toward one brand or manufacturer only (explain below).

_____ Specifications are unclear (explain below).

_____ We are unable to meet specifications.

_____ Insufficient time to respond to the Invitation for Bid.

_____ Our schedule would not permit us to perform.

_____ We are unable to meet bond requirements.

_____ We are unable to meet insurance requirements.

_____ We do not offer this product or service.

_____ Remove us from your bidders list for this commodity or service.

_____ Other (specify below).

REMARKS: _____

SIGNED: _____ NAME: _____
(Type or Print)

TITLE: _____ DATE: _____

FIRM NAME: _____
(if any)

ADDRESS: _____
(Street address) (City) (State) (Zip)

PHONE: _____ FAX: _____

EMAIL: _____

**SECTION I
INSTRUCTIONS TO BIDDERS**

1. **EXAMINATION OF BID DOCUMENT**-Before submitting a bid, bidders shall carefully examine the specifications and shall fully inform themselves as to all existing conditions and limitations. The bidder shall indicate in the bid the sum to cover the cost of all items included on the bid form.
2. **PREPARATION OF BID**-The bid shall be legibly prepared in ink or typed. If a unit price or extension already entered by the bidder on the Bid and Award form is to be altered, it shall be crossed out and the new unit price or extension entered above or below and initialed by the bidder with ink. The bid shall be legally signed and the complete address of the bidder given thereon.

All bids shall be tightly sealed in an envelope plainly marked SEALED BID and identified by project name, bid opening date and time. Bids opened by mistake, due to improper identification, will be so documented and resealed. The Purchasing Division will maintain and guarantee confidentiality of the contents until the specified opening date and time. Bids submitted by Fax machine will not be accepted.
3. **EXPLANATION TO BIDDERS**-Any binding explanation desired by a bidder regarding the meaning or interpretation of the Invitation for Bid (IFB) and attachments must be requested in writing, **at least business 5 days before the bid opening** (June 11 by 10:00am) so a reply may reach all prospective bidders before the submission of bids. Any information given to a prospective bidder concerning the IFB will be furnished to all prospective bidders as an amendment or addendum to the IFB if such information would be prejudicial to uninformed bidders. Receipt of amendments or addenda by a bidder must be acknowledged in the bid by attachment, or by letter or fax received before the time set for opening of bids. Oral explanation or instructions given prior to the opening will not be binding.
4. **CASH DISCOUNTS**-Discount offered for payment of less than thirty (30) days will not be considered in evaluating bids for award. Offered discounts of less than thirty (30) days will be taken if payment is made within the discount period, even though not considered in evaluation of the bid.
5. **WITHDRAWAL OF BIDS**-Bids may be withdrawn in person by a bidder or authorized representative, provided their identity is made known and a receipt is signed for the bid, but only if the withdrawal is made prior to the exact time set for receipt of bid. No bid may be withdrawn for at least ninety (90) days after bid opening.
6. **ALTERNATE BIDS**-bidders are cautioned that any alternate bid, unless specifically requested or any changes, insertions or omissions to the terms and conditions, specifications or any other requirement of this IFB may be considered non-responsive, and at the option of the City, result in rejection of the alternate bid.
7. **LATE BIDS**-Any bid received at the office designated herein after the exact time specified for receipt will not be considered. (Note: The City reserves the right to consider bids that have been determined by the City to be received late due to mishandling by the City after receipt of the bid and no award has been made.)
8. **UNIT PRICES**-If there is a discrepancy between unit prices and their extension, unit prices shall prevail.
9. **BID SUBMITTAL**- Bidders can submit sealed bids in one of the following ways:
 - 9.1. **Mail your bid**, to be received before the bid due date and time indicated in the bid document, to the City of Kalamazoo at the following address:

City of Kalamazoo
Purchasing Division
241 West South Street
Kalamazoo, MI 49007

- 9.2. **Deliver your bid to City Hall In-Person** before the bid due date and time indicated in the bid document.
- 9.3. **Deliver your bid to the Treasurer’s Office Payment Drop Box** located in the northwest corner of City Hall (see photos below) before the bid due date and time indicated in the bid document.



1. Open drop box located at City Hall.

2. Insert SEALED BID here.



- 10. **BID TABULATIONS-** The Purchasing Division makes an effort to post bid tabulations to the City of Kalamazoo website within 24 hours after the bid opening date and time at: <https://www.kalamazoocity.org/bidopportunities>. However, in certain cases the posting of the bid tabulation may extend beyond the 24-hour window.

SECTION II
BID AND AWARD

The undersigned having become thoroughly familiar with all of the bid/contract documents incorporated herein, the project site and the location conditions affecting the work, hereby proposes to perform everything required to be performed in strict conformity with the requirements of these documents, and to provide and furnish all the equipment, labor and materials necessary to complete in a professional manner the furnishing and installing of all of the following, meeting or exceeding the specifications as set forth herein for the prices as stated below.

BORN COURT WELL 1-7

Lump Sum Bid with prevailing wages will be the basis for the bid award. As supplemental information, Contractor shall provide Schedule of Values information as outlined below with the bid. All work necessary for a complete project must be included in the total lump sum bid even if not specifically noted in the Schedule of Values.

SCHEDULE OF VALUES

Item No.	Description	Quantity	Unit	Unit Price	Total Amount
1	Mobilization (5% max)	1	LS		
2	Temporary Traffic Control	1	LS		
3	Soil Erosion and Sedimentation Control	1	LS		
4	Linestop on Ex. 14" Watermain to Isolate (Includes Pavement Restoration)	1	Allowance	\$25,000.00	\$25,000.00
5	Abandon Ex. 14" Watermain with two Caps and Precast Restraint	1	LS		
6	Demolition/Removals (Fence, concrete pedestals, ex. equipment, electrical, other)	1	LS		
7	Furnish and Install Polyvinyl Fence and Gate	1	LS		
8	Extend Ex. Casings and Install Vent	1	LS		
9	Furnish and Install Pump and Motor Including Disinfection	1	LS		
10	Above Ground Piping, Fittings, Valves, Meter, Pressure and Temperature Transmitters, Pipe Supports	1	LS		
11	Below Ground Piping, Fittings, Valve and Connection to Existing Watermain Including Disinfection	1	LS		
12	Conduit and wire from Ex. Central Water Treatment Plant to Born Court Well 1-7	1	LS		
14	Electrical and Controls at the Born Court Well 1-7 Site	1	LS		
15	Restoration	1	LS		
TOTAL BID AMOUNT					

Bidder shall provide all of the information as requested herein with their bid. **Failure to do so and/or failure to provide post-bid requested information may be cause for rejecting the bid as non-responsive.**

Work shall start within **10** working days after receipt of notification by Contractor of Notice to Proceed, and final completion date on or before **March 27, 2026**.

Bidder/Contractor has examined and carefully studied the bidding documents and attachments, and acknowledges receipt of the following addenda:

Addendum No: _____

Dated: _____

By my signature below, I certify that the firm bidding on this contract, when making hiring decisions, does not use a past criminal conviction as a bar to or preclude a person with a criminal conviction from being considered for employment with the bidding firm unless otherwise precluded by federal or state law. I further certify that I have read and agree to be bound by the provisions of the City’s Non-Discrimination Clause found in Appendix A as updated by City Ordinance 1856.

Signed: _____ Name: _____

Title: _____

CITY OF KALAMAZOO EX-OFFENDER POLICY CHECKLIST

As part of the City’s commitment to reducing unacceptable poverty, encouraging rehabilitation, reducing recidivism and strengthening families in Kalamazoo, the City has updated its Purchasing Policy to ensure that firms with whom the City does business share in this commitment by utilizing hiring practices that do not unfairly deny people with arrest and conviction records gainful employment. *(Important: This requirement also extends to any subcontractors the bidder intends to use to fulfill the contract for goods or services being sought from the City.)*

Part I: Proof that the bidder does not inquire about an individual’s past arrest or criminal history on the bidders employment application form

- Attach a copy of the current application for employment being used by the bidder

Part II: Certification that the bidder does not use an individual’s past arrest or criminal history to unlawfully discriminate against them by checking *one or more* of the following:

- That pursuant to federal or state law bidder is precluded from hiring persons with certain criminal records from holding particular positions or engaging in certain occupations by providing a cite to the applicable statute or regulation; if checking this box, provide a citation to the applicable statute or rule upon which the bidder is relying:_____
- That bidder conducts criminal history background checks only as necessary, and only after making a conditional offer of employment; that any withdrawal of an offer of employment to an individual because of a past criminal history is job-related and consistent with business necessity after the individual has been provided an individualized assessment opportunity to review and challenge or supplement the history of past criminal conduct being relied upon by the bidder;
- That the use by bidder of criminal history background checks complies with the U.S. Equal Employment Opportunity Commission’s Enforcement Guidance on the Consideration of Arrest and Conviction Records in Employment Decisions and that the bidder has not had a determination rendered against it in past 7 years that it discriminated against a person through the use of an individual’s arrest or criminal history

I CERTIFY THAT THE ABOVE STATEMENTS ARE TRUE.

Date

Signature

Printed Name

Position

CITY OF KALAMAZOO
LOCAL PREFERENCE POLICY AND CERTIFICATION

The lowest responsive Kalamazoo County bidder whose bid is not low but falls within 2% of the lowest responsive bid is afforded the opportunity to become the successful bidder if it agrees to reduce its bid to match the lowest responsive bid. The City of Kalamazoo is the sole determiner whether a bidder is responsive, qualifies as a Kalamazoo County bidder, and if its bid is responsive to the City’s specifications, terms and conditions.

If the lowest Kalamazoo County bidder chooses not to match the lowest bid, the next lowest responsive Kalamazoo County bidder whose bid falls within 2% of the lowest bid, is given the opportunity to match the lowest responsive bid.

To qualify as a Kalamazoo County bidder, the bidder must meet both the following criteria:

1. Have a physical presence in Kalamazoo County by maintaining a permanent office, factory or other facility in Kalamazoo County with employees working in Kalamazoo County.
2. Have paid real or personal property taxes related to said business to the City of Kalamazoo, County of Kalamazoo or other municipal corporation within Kalamazoo County in the previous tax year, except that a non-profit entity need not meet this requirement.

This local preference policy applies only to purchases for materials, supplies, capital outlay, and services for maintenance, repair or operation of City facilities that are over \$25,000. If more than 50% of the contract is sub-contracted to firms located outside of Kalamazoo County that bid does not qualify for the local preference policy outlined above. The local preference policy will not apply if prohibited by law. The Purchasing Agent has the authority to finally determine if the bidder qualifies as a Kalamazoo County bidder as set forth herein. The Purchasing Agent may take into account the permanency of the business in Kalamazoo, and whether the business appears to be claiming to be a Kalamazoo County business solely or primarily to qualify as a Kalamazoo County business under this Resolution, and any other material factors.

CERTIFICATION

If you qualify as a Kalamazoo County bidder and wish to be considered for the local preference provisions as provided above please certify that fact by providing the information requested below and attesting to its accuracy.

Firm Name: _____

Street Address of Business: _____

City, State, and Zip Code: _____

Number of employees working in Kalamazoo County: _____

Name the city or township to which business real and/or personal property taxes are paid or provide non-profit status: _____

The above information is accurate:

Signature: _____ Date: _____

Title: _____

REFERENCE QUESTIONNAIRE

Please answer the following questions completely.

1. Firm name: _____
2. Established: Year _____ Number of Employees: _____
3. Type of organization:
 - a. Individual: _____
 - b. Partnership: _____
 - c. Corporation: _____
 - d. Other: _____
4. Former firm name(s) if any, and year(s) in business:

5. Include at least 5 references of contracts for similar work performed over the last five (5) years. The City of Kalamazoo Water System is a Type 1 Public Water Supply. For the protection of public health, the City requires that any contractor performing work on the water system is qualified with experience working on other Type 1 Public Water Supply Systems with projects of similar scope to this bid.
Include: owner, contact person and phone number and description of work performed.
 - 5.1 Company Name: _____
Address: _____
Phone: _____
Contact: _____
Type of work or contract: _____
 - 5.2 Company Name: _____
Address: _____
Phone: _____
Contact: _____
Type of work or contract: _____
 - 5.3 Company Name: _____
Address: _____
Phone: _____
Contact: _____
Type of work or contract: _____

5.4 Company Name: _____
Address: _____
Phone: _____
Contact: _____
Type of work or contract: _____

5.5 Company Name: _____
Address: _____
Phone: _____
Contact: _____
Type of work or contract: _____

I hereby certify that all of the information provided is true and answered to the best of my ability.

Signed: _____ Name: _____
(type or print)

Title: _____ Date: _____

I hereby state that all of the information I have provided is true, accurate and complete. I hereby state that I have the authority to submit this bid which will become a binding contract if accepted by the City of Kalamazoo. I hereby state that I have not communicated with nor otherwise colluded with any other bidder, nor have I made any agreement with nor offered/accepted anything of value to/from an official or employee of the City of Kalamazoo that would tend to destroy or hinder free competition.

The firm's identification information provided will be used by the City for purchase orders, payment, and other contractual purposes. If the contractual relationship is with, or the payment made to, another firm please provide a complete explanation on your letterhead and attach to your bid. Please provide for accounts payable purposes:

Tax Identification Number (Federal ID): _____

Remittance Address: _____

Financial Contact Name: _____ Financial Contact Phone Number: _____

Financial Contact Email Address: _____

I hereby state that I have read, understand and agree to be bound by all terms and conditions of this bid document.

SIGNED: _____ NAME: _____
(Type or Print)

TITLE: _____ DATE: _____

FIRM NAME: _____
(if any)

ADDRESS: _____
(Street address) (City) (State) (Zip)

PHONE: _____ FAX: _____

EMAIL ADDRESS: _____

FOR CITY USE ONLY - DO NOT WRITE BELOW

**SECTION III
CITY OF KALAMAZOO
INDEMNITY AND INSURANCE**

Contractor, or any of their subcontractors, shall not commence work under this contract until they have obtained the insurance required under this paragraph, and shall keep such insurance in force during the entire life of this contract. All coverage shall be with insurance companies licensed and admitted to do business in the State of Michigan and acceptable to the City of Kalamazoo within ten (10) days of the Notice of Award. The requirements below should not be interpreted to limit the liability of the Contractor. All deductibles and SIR's are the responsibility of the Contractor.

The Contractor shall procure and maintain the following insurance coverage:

Workers' Compensation Insurance including Employers' Liability Coverage, in accordance with all applicable statutes of the State of Michigan.

Commercial General Liability Insurance on an "Occurrence Basis" with limits of liability not less than \$1,000,000 per occurrence and aggregate. Coverage shall include the following extensions: (A) Contractual Liability; (B) Products and Completed Operations; (C) Independent Contractors Coverage; (D) Broad Form General Liability Extensions or equivalent, if not already included and (E) XCU coverage if the nature of the contract requires XC or U work.

Automobile Liability including Michigan No-Fault Coverages, with limits of liability not less than \$1,000,000 per occurrence, combined single limit for Bodily Injury, and Property Damage. Coverage shall include all owned vehicles, all non-owned vehicles, and all hired vehicles.

Additional Insured: Commercial General Liability and Automobile Liability, as described above, shall include an endorsement stating that the following shall be *Additional Insureds*: The City of Kalamazoo, all elected and appointed officials, all employees and volunteers, all boards, commissions, and/or authorities and board members, including employees and volunteers thereof. It is understood and agreed that by naming the City of Kalamazoo as additional insured, coverage afforded is considered to be primary and any other insurance the City of Kalamazoo may have in effect shall be considered secondary and/or excess.

To the fullest extent permitted by law the Contractor agrees to defend, pay on behalf of, indemnify, and hold harmless the City of Kalamazoo, its elected and appointed officials, employees, agents and volunteers, and others working on behalf of the City of Kalamazoo against any and all claims, demands, suits, or loss, including all costs connected therewith, and for any damages which may be asserted, claimed, or recovered against or from the City of Kalamazoo, by reason of personal injury, including bodily injury or death and/or property damage, including loss of use thereof, which arises out of, or is in any way connected or associated with this contract.

Cancellation Notice: All policies, as described above, shall include an endorsement stating that it is understood and agreed that thirty (30) days, or ten (10) days for non-payment of premium, Advance Written Notice of Cancellation, Non-Renewal, Reduction, and/or Material Change shall be sent to: City of Kalamazoo, Purchasing Division, 241 W. South Street, Kalamazoo, MI 49007.

Proof of Insurance Coverage: The Contractor shall provide the City of Kalamazoo at the time that the contracts are returned by him/her for execution, or within 10 days of Notice of Award, whichever is earlier, a Certificate of Insurance as well as the required endorsements. In lieu of required endorsements, if applicable, a copy of the policy sections where coverage is provided for additional insured and cancellation notice would be acceptable. Copies or certified copies of all policies mentioned above shall be furnished, if so requested.

INDEMNITY AND INSURANCE

Continued

If any of the above coverages expire during the term of this contract, the Contractor shall deliver renewal certificates and/or policies to City of Kalamazoo at least ten (10) days prior to the expiration date.

Scope of Coverage: The above requirements and conditions shall not be interpreted to limit the liability of the Contractor under this Contract, but shall be interpreted to provide the greatest benefit to the City and its officers and employees. The above listed coverages shall protect the Contractor, its employees, agents, representatives and subcontractors against claims arising out of the work performed. It shall be the Contractor's responsibility to provide similar insurance for each subcontractor or to provide evidence that each subcontractor carries such insurance in like amount prior to the time such subcontractor proceeds to perform under the contract.

**SECTION IV
SPECIAL REQUIREMENTS**

1. BID BOND/GUARANTEE

The bid must be accompanied by a bid bond which shall not be less than five (5%) percent of the total amount of the bid. No bid will be considered unless it is accompanied by the required guarantee. The bid guarantee shall ensure the execution of the bid and award, and the furnishing of a performance bond and a labor and material bond (A and B below) by the successful bidder. (Contractors Note: A cashier's or certified check in lieu of a bid bond is **NOT** acceptable.)

A. PERFORMANCE BOND

A performance bond shall be furnished in the full amount of the contract ensuring the City of faithful performance of all the provisions of the contract, and the satisfactory performance of any equipment required hereunder. The bond shall also ensure the City against defective workmanship and/or materials.

B. LABOR AND MATERIAL (PAYMENT) BOND

A labor and material (payment) bond shall be furnished for the period covered by the contract, in the full amount of the contract for the protection of labor and material suppliers and sub-contractors.

Bonds shall be secured by a guaranty or a surety company listed in the latest issue of the U.S. Treasury, circular 570, and licensed to do business in the State of Michigan, and written in favor of the City of Kalamazoo. The amount of such bonds shall be within the maximum amount specified for such company in said circular 570. The bonds shall be accompanied by a power of attorney showing authority of the bonding agent to sign such bonds on behalf of the guaranty or surety company. The cost of the bonds shall be borne by the Contractor.

Failure of the Contractor to supply the required bonds within ten (10) days after Notice of Award, or within such extended period as the Purchasing Agent may agree to, shall constitute a default and the City of Kalamazoo may either award this contract to the next lowest bidder or re-advertise for bids and may charge against the Contractor for the difference between the amount of the bid and the amount for which a contract for the work is subsequently executed, irrespective of whether the amount thus due exceeds the amount of the bid bond. If a more favorable bid is received by re-advertising, the defaulting bidder shall have no claim against the City of Kalamazoo for a refund.

2. WAIVERS OF LIEN

Upon completion of all work and request for final payment, the Contractor shall furnish a 100% waiver of lien from each supplier and sub-contractor covering all items of the work. Failure to supply waivers of lien for the entire job upon completion and final payment request will be considered grounds for withholding final payment.

3. SUBCONTRACTORS

- A. Contractors shall state on the Bid and Award page any and all subcontractors to be associated with their bid, including the type work to be performed. Any and all subcontractors shall be bound by all of the terms, conditions and requirements of the contract; however, the prime contractor shall be responsible for the performance of the total work requirements.
- B. The Contractor shall cooperate with the City of Kalamazoo in meeting its commitments and goals with regard to maximum utilization of minority and women business enterprise, and shall use its best efforts to ensure that minority and women business enterprises have maximum practicable opportunity to compete for subcontract work under this agreement.

4. PREVAILING WAGES

The successful bidder will be required to comply with Section 2-125 of the Code of Ordinances of the City of Kalamazoo regarding prevailing wages and Appendix B attached, incorporated herein by reference. Special note: This provision applies only to projects in excess of \$100,000 for City (\$2,000 federal) funded projects.

The City's requirements as it relates to prevailing wages includes a meeting with the City's Purchasing Division **prior** to work and payroll and work monitoring during the duration of the contract. Please contact Purchasing at (269) 337-8020 if you have any questions regarding Davis-Bacon provisions.

SECTION V
GENERAL PROVISIONS

1. INTENT

It is the intent of these plans and specifications to provide for a contractor who shall provide all labor, materials, tools and equipment necessary to perform in a professional manner for the **BORN COURT WELL 1-7 Project** as described in the specifications and bid document.

2. SCOPE OF WORK

This contract includes, but is not limited to: All work as shown on the plans and described in the specifications for the installation of a pump and associated discharge piping and meter at Born Court Well 1-7 in the City of Kalamazoo.

3. QUANTITIES

The quantities shown or indicated on the plans are only estimated. Payment will be made for the full and complete work based upon the lump sum bid.

4. UNIT PRICING

The unit price, including its pro-rata share of overhead, multiplied by the quantity shown shall represent the total bid and shall be held firm for the life of this contract. Any bid not conforming to this requirement may be rejected as non-responsive.

5. INSPECTION OF WORK

The City may maintain inspectors on the job who shall at all times have access to work.

6. INSPECTION OF SITE

Each bidder shall visit the site of the proposed work and fully acquaint himself/herself with the existing conditions relating to construction and labor and shall fully inform himself/herself as to the facilities involved and the difficulties and restrictions attending the performance of this contract. The bidder shall thoroughly examine and become familiar with the drawings, specifications, and all other bid/contract documents. The Contractor, by the execution of this contract, shall in no way be relieved of any obligation under it due to his/her failure to receive or examine any form or legal instrument, or to visit the site and acquaint himself/herself with the conditions there existing. No allowance shall be made subsequently in this connection in behalf of the Contractor for any negligence of his/her part. For inspection call the Public Services Department, Water Resources Division.

7. INSPECTION AND TESTING

The Contractor shall give the City's Project Manager (Project Manager) timely notice of readiness of the work for all required inspections, tests or approvals, and shall cooperate with inspections and testing personnel to facilitate required inspections or tests. Verification that testing required by the contract has been completed on one phase of the project prior to proceeding to the next phase is the responsibility of the Contractor. In the event that the project has proceeded without required testing, the Contractor shall insure that the required testing is obtained retroactively and shall provide access for testing as necessary at his/her sole expense.

8. MATERIALS INSPECTION AND RESPONSIBILITY

- 8.1 The Project Manager shall have the right to inspect any materials to be used in carrying out the terms of the contract.
- 8.2 The City does not assume any responsibility for the contracted quality and standard of all materials, equipment, components or completed work furnished under this contract.
- 8.3 Any materials, equipment, components or completed work which does not comply with contract specifications, MDOT, or State codes may be rejected by the City, and shall be replaced by the Contractor at no cost to the City.
- 8.4 Any materials, equipment or components rejected shall be removed within a reasonable period of time from the premises of the City at the entire expense of the Contractor after notice has been given by the City to the Contractor that such materials, equipment or components have been rejected.

9. LAYING OUT WORK

Before submitting a bid the Contractor shall verify all measurements and shall be responsible for the correctness of same. No extra charge or compensation will be allowed on account of differences between actual dimensions and the measurements indicated on the drawings. Any difference that may be found shall be submitted to the City Engineer for consideration before proceeding. The City Engineer will provide staking for the project.

10. SUPERVISION

The Contractor shall employ an experienced superintendent or foreperson on the job at all times.

11. TEMPORARY UTILITIES

- 11.1 Temporary or construction water will NOT be available on the sites. The Contractor must provide for drinking water.
- 11.2 Temporary toilets: To be supplied by the Contractor as may be necessary.

12. SITE SECURITY

The Contractor shall be responsible for job site security of all materials and tools provided by him/her and no claim for loss or damage will be considered by the City.

13. TARDINESS

Construction delays resulting from tardiness on the part of the Contractor will be reviewed by the City in the event of any request for contract extension by the Contractor.

14. **PROGRESS SCHEDULE**

- 14.1 After receipt of Notice to Proceed, work shall start within 10 days unless otherwise agreed to by the Project Manager.
- 14.2 **Work shall begin on or about July 7, 2025 and shall have a final completion date on or before March 27, 2026.**
- 14.3 Work of a similar nature may be added to this contract if agreed to by the City and the Contractor. In the event that work is added, the progress schedule for the work will remain unchanged. Any contract time added for additional work will be applied to that additional work only, and cannot be added to items in the original contract. Any work done on the items in the original contract past the number of working days stated herein will be subject to liquidated damages regardless of any work that may be added at a later date.
- 14.4 The Contractor will be required to meet with the Public Services representatives to work out detailed progress schedule. The schedule for this meeting will be within two weeks after contract award has been made.
- 14.5 The named sub-contractor(s) for all items shall also be present at the scheduled meeting and they will be required to sign the Progress Schedule to indicate their approval of the scheduled dates of work set forth in the Progress Schedule.
- 14.6 The Progress Schedule shall include, as a minimum, the starting and completion dates for major items, and where specified in the bid document the date the project is to be opened to traffic as well as the final project completion date specified in the bid documents. The Progress Schedule shall be coordinated with all aspects of the work occurring at the site.
- 14.7 Failure on the part of the Contractor to carry out the provisions of the Progress Schedule as established may be considered sufficient cause to prevent bidding future projects until a satisfactory rate of progress is again established.
- 14.8 The starting date and the contract time to the completion date for this project may be adjusted by Public Services without imposing liquidated damages upon the receipt of satisfactory documented evidence that unforeseen delayed delivery of critical materials will prevent the orderly prosecution of the work.
- 14.9 Also see Section 1.06 “Progress Schedule” of Specifications

15. **CONSTRUCTION SCHEDULE AND COORDINATION**

- 15.1 The Contractor shall supply the City with an agreeable construction schedule before commencing work on this contract. This schedule shall detail beginning and completion dates for each major component of the project.
- 15.2 The Contractor shall coordinate and cooperate with all other contractors who may be working on the site in order to allow for the orderly progress of work being done.
- 15.3 The Contractor is required to keep the Project Manager fully informed of any proposed work which will tend to interfere with the existing operations at the site.
- 15.4 The Contractor shall schedule all work to accommodate the City's schedule. In the event Contractor's schedule falls on weekends, nights or overtime work is required, no additional compensation will be allowed. All work shall be part of this contract without regard to when it is done.
- 15.5 The Contractor shall not schedule work on City-observed holidays.

16. **CONTRACTOR COORDINATION**

- 16.1 The Contractor shall make every effort to coordinate every aspect of his work with that of other contractors on the site to assure an efficiently managed and proper installation.
- 16.2 Consideration shall be given to timing of construction, maintaining adequate construction access, and construction staging. Any costs associated with this coordination shall be included in the contract.

17. **COORDINATING CLAUSE**

The Contractor's attention is called to 104.08 of the MDOT 2020 Standard Specifications for Construction entitled "Cooperation by Contractor."

18. **ADDITIONS**

- 18.1 Any modification to the contract shall be subject to prior approval by the Purchasing Agent. City Commission approval may also be required.
- 18.2 Prices for additional work required are not requested in the itemized listing contained herein for the base project. Should additional work be authorized, compensation shall be made on the basis of price or prices to be mutually agreed upon. Such additional work shall not begin until approved.

19. **MAINTAINING TRAFFIC**

- 19.1 This work shall be in accordance with the requirements of Section 812 of the MDOT Standard Specifications for Construction and as specified herein. The Contractor is advised that the current Michigan Manual of Uniform Traffic Control Devices is hereby established as governing all work in connection with traffic control devices, barricade lighting, etc. required on this project.
- 19.2 The Contractor shall furnish, erect, maintain and, upon completion of the work, remove all traffic control devices and barricade lights within the project and around the perimeter of the project for the safety and protection of through and local traffic. This includes, but is not limited to: Advance, regulatory and warning signs; barricades and channeling devices at intersecting streets on which traffic is to be maintained; barricades at the ends of the project and at right-of-way lines for intersecting streets which are to be closed with the first usable street on each side of the project. Traffic regulators, where required by the Engineer, are included.
- 19.3 Where the existing pavement or partial widths of new pavement are to be utilized for the maintenance of through and local traffic, drum type barricades will be required at 50' intervals or as directed by the Engineer for channeling and directing traffic through the construction area.
- 19.4 Through traffic shall be maintained utilizing sidewalk closures with detours and traffic shifts per MDOT traffic and safety details.
- 19.5 Protection of all pedestrian traffic shall be maintained at all times.
- 19.6 Payment for the traffic control devices shall be based on the contract lump sum price.
- 19.7 Under Article 812.04.D "Operated Pay Items" the term 'Relocating' shall include the relocating of the item from any street covered by the contract to any other street covered by the contract.

Special Restrictions: Access to frontage properties shall be maintained as much as practical. Emergency access shall be maintained at all times. The Contractor shall maintain two-way traffic with flag control as needed when the road is restricted to only one traffic lane.

20. LIQUIDATED DAMAGES

20.1 Liquidated damages, if applicable, shall be \$500.00 a day regardless of contract size.

20.2 The provisions of Article 108.11B of the MDOT 2003 Standard Specifications for Construction for reducing liquidated damages of 50 percent of the amount indicated in Table 108-1 of article 108.11C for projects where traffic is maintained during construction will not apply.

21. REMOVAL OF RUBBISH

The Contractor shall daily remove all rubbish and accumulated materials due to his/her construction.

22. SITE ACCESS

The City will provide fair and reasonable access to the job site within the working schedules of both parties.

23. GUARANTEE

The Contractor shall guarantee all of his/her work for a period of two (2) years following the date of final acceptance of the completed work and shall repair, replace or make good any materials or work which fail to function or perform or be found defective, without cost to the City.

24. SAFETY

The Contractor shall comply with all applicable OSHA and MIOSHA regulations.

25. PAY ESTIMATES

The Contractor shall be responsible for the generation of invoices for payment. Payment will be generated by the City based upon an approved invoice. Recommended frequency of payment is monthly, however, frequency of payment will not exceed bi-weekly.

26. PRODUCT/SYSTEM SUBSTITUTIONS

Submit a written request, to be received not later than 10 days prior to scheduled bid opening, for Substitution of any Product not named. If no substitutions are submitted, it will be reasonably concluded by the Owner and Landscape Architect that the specified product will be incorporated into the Work and the Bidder will be committed to supplying the specified product.

26.1 Describe in detail any variance to the Product specified. All proposed substitution for specified items shall be substantially the same size (height, length, width, diameter, etc.), type, color, construction quality and shall meet the design intent to be considered for substitution for the Product specified.

26.2 Document each request with complete data substantiating compliance of proposed Substitution with Product specified including written certification that Product conforms to or exceeds all requirements of the Product specified.

26.3 Document all coordination information, including a list of changes or modifications needed to the Contract Documents or other parts of the Work and to construction performed by the Owner and Separate Contractors that will become necessary to accommodate the proposed substitution.

26.4 Provide name, address and telephone number of manufacturer's authorized representative.

26.5 Submit three copies of all documents for each request for Substitution for consideration.

26.6 Approval of the Substitution request, if given, will be in the form of an addendum issued prior to scheduled opening date and hour at local time.

27. SAMPLES AND DEMONSTRATIONS

Evidence in the form of samples may be requested. Such samples are to be furnished after the date of bid opening only upon request of The City unless otherwise stated in the bid proposal. If samples should be requested, such samples must be received by The City no later than seven (7) days after formal request is made. When required, The City may request full demonstrations of any unit(s) bid prior to the award of any contract. Samples, when requested, must be furnished free of expense to The City and if not used in testing or destroyed, will upon request within thirty (30) days of bid award be returned at the bidder's request.

28. ACCEPTANCE OF MATERIAL

The material delivered under this proposal shall remain the property of the seller until a physical inspection and actual usage of the material and/or services is made and thereafter accepted to the satisfaction of The City and must comply with the terms herein, and be full in accord with specifications and of the highest quality. In the event the material and/or service supplied to The City is found to be defective or does not conform to specifications, The City reserves the right to cancel the order upon written notice to the seller and return the product to seller at the seller's expense.

29. VARIATIONS TO SPECIFICATIONS

For purposes of evaluation, the bidder **MUST** indicate any variances from our specifications, terms and/or conditions, no matter how slight. If variations are not stated in the proposal, it will be assumed that the product or service fully complies with our specifications, terms and conditions.

30. SAFETY STANDARDS

The bidder warrants that the products supplied to The City conform in all respects to the standards set forth in the Occupational Safety and Health Act of 1970 and its amendments and the failure to comply with this condition will be considered a breach of contract.

31. MANUFACTURER'S CERTIFICATION

The City reserves the right to request from bidders separate manufacturer certification of all statements made in the bid.

32. PROTECTION OF WORK

The Contractor shall maintain adequate protection of all his/her work from damage and shall protect all public and private abutting property from injury or loss arising in connection with this contract.

33. PROTECTION OF PROPERTY

33.1 The Contractor shall confine his/her equipment and operations to those areas of the work site necessary for the completion of the work, or as authorized by the Project Manager. The Contractor shall protect and preserve from damage any facilities, utilities or features including trees, shrubs and turf which are not required to be disturbed by the requirements of the work.

33.2 The Contractor shall be responsible to determine the location of and to protect from damage any utilities or other improvements.

34. MANDATORY PRE-BID MEETING

A mandatory pre-bid meeting will be held on June 10, 2025, at 9:00 a.m. in the Stockbridge Facility, Main Conference Room, 415 E Stockbridge, Kalamazoo, MI. Before submitting bids for his/her work, the Contractor shall be responsible for examining the work sites and satisfying himself/herself as to the existing conditions under which he/she will be obligated to operate, or that in any way affects the work under this contract. No allowance shall be made subsequently, on behalf of the Contractor, for any negligence on his/her part. **Questions may be emailed to Anna Crandall, at crandalla@kalamazoo-city.org by 10:00 a.m. on June 11, 2025.**

35. QUESTIONS

Bidders shall address questions regarding the specifications to Anna Crandall, P.E., Assistant City Engineer – Water Resources at crandalla@kalamazoo-city.org. (This does not relieve the requirements of Page 1, Item 3.) Questions regarding terms, conditions and other related bid requirements may be addressed to Scott Shaffer, Buyer at shaffers@kalamazoo-city.org or (269) 337-8444.

**SECTION VI
TERMS AND CONDITIONS**

1. AWARD OF CONTRACT

A. This contract will be awarded to that responsible bidder whose bid, conforming to this solicitation, will be most advantageous to the City, price and other factors considered. The City reserves the right to accept or reject any or all bids and waive informalities and minor irregularities in bids received. Other factors include, as an example but not limited to, delivery time, conformance to specifications, incidental costs such as demurrage and deposits, etc.

Notification of award will be in writing by the Purchasing Agent. Upon notification, the Contractor shall submit to the Purchasing Division all required insurance certificates (if required) and such other documentation as may be requested or required hereunder. Upon their receipt and subsequent approval by the City, the Purchasing Agent will forward to the Contractor a written **NOTICE TO PROCEED**. Work shall **NOT** be started until such **NOTICE TO PROCEED** is received by the Contractor.

B. Unilateral changes in bid prices by the bidder shall not be allowed. However, the City, at its sole option, reserves the right to negotiate with bidders in the event of, but not limited to:

- 1) No bids received;
- 2) A single bid being received; or
- 3) Prices quoted are over budget and/or unreasonable.

2. COMPLETE CONTRACT

This bid document together with its addenda, amendments, attachments and modifications, when executed, becomes the complete contract between the parties hereto, and no verbal or oral promises or representations made in conjunction with the negotiation of this contract shall be binding on either party.

3. SUBCONTRACTORS - NON ASSIGNMENT

Bidders shall state in writing any and all sub-contractors to be associated with this bid, including the type of work to be performed. The Contractor shall cooperate with the City of Kalamazoo in meeting its commitments and goals with regard to maximum utilization of minority and women-owned business enterprises.

The Contractor hereby agrees and understands that the contract resulting from this solicitation shall not be transferred, assigned or sublet without prior written consent of the City of Kalamazoo.

4. TAXES

The City of Kalamazoo is exempt from all federal excise tax and state sales and use taxes. However, depending upon the situation, the vendor or contractor may not be exempt from said taxes and the City of Kalamazoo is making no representation as to any such exemption.

5. **INVOICING**

All original invoice(s) will be sent to the Financial Services Division, 241 W. South Street, Kalamazoo, MI 49007 or via email at apinvoice@kalamazoo-city.org. The Finance Division processes payments after receipt of an original invoice from the Contractor and approval by the department. The City of Kalamazoo’s policy is to pay invoice(s) within 30 days from the receipt of the original invoice, if the services or supplies are satisfactory and the proper paperwork and procedures have been followed. **In order to guarantee payment to the vendor on a timely basis, the vendor needs to receive a purchase order number before supplying the City of Kalamazoo with goods or services.** All original, and copies of original invoice(s), will clearly state which purchase order they are being billed against.

The City of Kalamazoo is a government municipality and therefore is tax exempt from all sales tax.

The vendor is responsible for supplying the Finance Division with a copy of their W9 if they are providing a service to the City of Kalamazoo.

6. **PAYMENTS**

Upon issuance of certificates of Payment by the Architect/Engineer for labor and material incorporated in the work and the materials suitably stored at the site payment shall be made up to ninety (90%) percent of the value thereof.

When the cumulative total of payment is equal to fifty (50%) percent of the contract sum, subsequent payments will be made in the full amount for labor and material certified by the Architect/Engineer.

The amount retained shall be held until final acceptance of the work, receipt of all payrolls, releases, and waiver of liens.

7. **CHANGES AND/OR CONTRACT MODIFICATIONS**

The City reserves the right to increase or decrease quantities, service or requirements, or make any changes necessary at any time during the term of this contract, or any negotiated extension thereof. Price adjustments due to any of the foregoing changes shall be negotiated and mutually agreed upon by the Contractor and the City.

Changes of any nature after contract award which reflect an increase or decrease in requirements or costs shall not be permitted without prior approval by the Purchasing Agent. City Commission approval may also be required. **SUCH CHANGES, IF PERFORMED IN ADVANCE OF PURCHASING AGENT APPROVAL, MAY BE SUBJECT TO DENIAL AND NON-PAYMENT.**

8. LAWS, ORDINANCES AND REGULATIONS

The Contractor shall keep himself/herself fully informed of all local, state and federal laws, ordinances and regulations in any manner affecting those engaged or employed in the work and the equipment used. Contractor and/or employees shall, at all times, serve and comply with such laws, ordinances and regulations.

Any permits, licenses, certificates or fees required for the performance of the work shall be obtained and paid for by the Contractor.

This contract shall be governed by the laws of the State of Michigan.

9. RIGHT TO AUDIT

The City or its designee shall be entitled to audit all of the Contractor's records, and shall be allowed to interview any of the Contractor's employees, throughout the term of this contract and for a period of three years after final payment or longer if required by law to the extent necessary to adequately permit evaluation and verification of:

- A. Contractor compliance with contract requirements,
- B. Compliance with provisions for pricing change orders, invoices or claims submitted by the Contractor or any of his payees.

10. HOLD HARMLESS

If the acts or omissions of the Contractor/Vendor or its employees, agents or officers, cause injury to person or property, the Contractor/Vendor shall defend, indemnify and save harmless the City of Kalamazoo, their agents, officials, and employees against all claims, judgments, losses, damages, demands, and payments of any kind to persons or property to the extent occasioned from any claim or demand arising therefrom.

11. DEFAULT

The City may at any time, by written notice to the Contractor, terminate this contract and the Contractor's right to proceed with the work, for just cause, which shall include, but is not limited to the following:

- A. Failure to provide insurance and bonds (when called for), in the exact amounts and within the time specified or any extension thereof.
- B. Failure to make delivery of the supplies, or to perform the services within the time specified herein, or any extension thereof.
- C. The unauthorized substitution of articles for those bid and specified.
- D. Failure to make progress if such failure endangers performance of the contract in accordance with its terms.
- E. Failure to perform in compliance with any provision of the contract.

DEFAULT (cont.)

- F. **Standard of Performance** - Contractor guarantees the performance of the commodities, goods or services rendered herein in accordance with the accepted standards of the industry or industries concerned herein, except that if this specification calls for higher standards, then such higher standards shall be provided.

Upon notice by the City of Contractor's failure to comply with such standards or to otherwise be in default of this contract in any manner following the Notice to Proceed, Contractor shall immediately remedy said defective performance in a manner acceptable to the City. Should Contractor fail to immediately correct said defective performance, said failure shall be considered a breach of this contract and grounds for termination of the same by the City.

In the event of any breach of this contract by Contractor, Contractor shall pay any cost to the City caused by said breach including but not limited to the replacement cost of such goods or services with another Contractor.

The City reserves the right to withhold any or all payments until any defects in performance have been satisfactorily corrected.

In the event the Contractor is in breach of this contract in any manner, and such breach has not been satisfactorily corrected, the City may bar the Contractor from being awarded any future City contracts.

- G. All remedies available to the City herein are cumulative and the election of one remedy by the City shall not be a waiver of any other remedy available to the City.

12. TERMINATION OF CONTRACT

The City may, at any time and without cause, suspend the work of this contract for a period of not more than ninety days after providing notice in writing to the Contractor. The Contractor shall be allowed an adjustment in the contract price or an extension of the contract times, or both, directly attributable to the suspension if Contractor makes an approved claim.

The City may, without prejudice to any other right or remedy of the City, and with or without cause, terminate the contract by giving seven days written notice to the Contractor. In such case the Contractor shall be paid, without duplication, for the following items:

- A. Completed and acceptable work executed in accordance with the contract documents prior to the effective date of termination, including fair and reasonable sums for overhead and profit on such work;
- B. Expenses sustained prior to the effective date of termination in performing services and furnishing labor, materials or equipment as required by the contract documents in connection with uncompleted work, plus fair and reasonable sums for overhead and profit on such expenses;
- C. All documented claims, costs, losses and damages incurred in settlement of terminated contracts with Subcontractors, Suppliers and others; and
- D. Reasonable expenses directly attributable to termination.

The Contractor shall not be paid on account of loss of anticipated profits or revenue or other economic loss arising out of or resulting from such termination.

13. INDEPENDENT CONTRACTOR

At all times, the Contractor, any of his/her employees, or his/her sub-contractors and their subsequent employees shall be considered independent contractors and not as City employees. The Contractor shall exercise all supervisory control and general control over all workers' duties, payment of wages to Contractor's employees and the right to hire, fire and discipline their employees and workers. As an independent contractor, payment under this contract shall not be subject to any withholding for tax, social security or other purposes, nor shall the Contractor or his/her employees be entitled to sick leave, pension benefit, vacation, medical benefits, life insurance or workers' unemployment compensation or the like.

14. PROJECT SUPERVISOR

The Contractor shall employ an individual to act as Project Supervisor. The Project Supervisor shall be available to the Contractor's workers and the Project Manager at all times by use of a beeper or other reliable means. The Project Supervisor shall prepare daily work plans for the employees, monitor employee performance, attendance and punctuality; and work closely with the City's Project Manager in assuring contract compliance.

15. MEETINGS

The Contractor and/or Project Supervisor shall be available to meet with the Department Head or Project Manager at a mutually agreeable time to discuss problems, issues or concerns relative to the contract. Either party may call a meeting at any time. When such a request for a meeting is made, the meeting date shall, in no case exceed five (5) working days after the request; and, if in the sole opinion of the Department Head, the severity of the circumstance warrants, no more than one (1) working day.

16. INSPECTION OF WORK SITE

Before submitting bids or quotes for work, the Contractor shall be responsible for examining the work site and satisfying himself/herself as to the existing conditions under which he/she will be obligated to operate, or that in any way affects the work under this contract. No allowance shall be made subsequently, on behalf of the Contractor, for any negligence on his/her part.

17. CONTRACT PERIOD, EXTENSIONS, CANCELLATION

- A. The contract shall be in effect for the term stated in the specifications.
- B. The City may opt to extend this contract upon mutual agreement of both parties. The number of extensions shall be limited to that stated in the specifications.
- C. The City may, from time to time, find it necessary to continue this contract on a month-to-month basis only, not to exceed a six (6) month period. Such month-to-month extended periods shall be by mutual agreement of both parties, with all provisions of the original contract or any extension thereof remaining in full force and effect.
- D. All contracts, extensions and cost increases are subject to availability of funds and the approval of the City Commission (if required).

CONTRACT PERIOD, EXTENSIONS, CANCELLATION (*cont.*)

- E. The City reserves the right to cancel the contract due to non-appropriation of funds by the City with thirty (30) days written notice.
- F. Either party may terminate the contract (or any extension thereof) without cause at the end of any twelve (12) month term by giving written notice of such intent at least 60 days prior to the end of said twelve (12) month term.
- G. All notices are in effect commencing with the date of mailing. Written notices may be delivered in person or sent by First Class mail; faxed or emailed to the last known address.
- H. If cancellation is for default of contract due to non-performance, the contract may be canceled at any time (see Item 11, DEFAULT)

APPENDIX A
NON-DISCRIMINATION CLAUSE FOR ALL CITY OF KALAMAZOO CONTRACTS

The Contractor agrees to comply with the Federal Civil Rights Act of 1964 as amended; the Federal Civil Rights Act of 1991 as amended; the Americans With Disabilities Act of 1990 as amended; the Elliott-Larson Civil Rights Act, Act. No. 453, Public Act of 1976 as amended; the Michigan Handicappers Civil Rights Act, Act No. 220, Public Act of 1976 as amended, City Ordinance 1856 and all other applicable Federal and State laws. The Contractor agrees as follows:

1. The Contractor will not discriminate against any employee or applicant for employment because of race, color, religion, national origin, sex, age, height, weight, marital status, physical or mental disability, family status, sexual orientation or gender identity that is unrelated to the individual's ability to perform the duties of the particular job or position. Such action shall include, but not be limited to the following: employment, upgrading, demotion or transfer, recruitment advertising, layoff or termination; rates of pay or other forms of compensations; and selection for training, including apprenticeship.
2. The Contractor will, in all solicitations or advertisements for employees placed by or on behalf of the Contractor, state that all qualified applicants will receive consideration for employment without regard to race, color, religion, national origin, sex, age, height, weight, marital status, physical or mental disability family status, sexual orientation or gender identity that is unrelated to the individual's ability to perform the duties of the particular job or position.
3. If requested by the City, the Contractor shall furnish information regarding practices, policies and programs and employment statistics for the Contractor and subcontractors. The Contractor and subcontractors shall permit access to all books, records and accounts regarding employment practices by agents and representatives of the City duly charged with investigative duties to assure compliance with this clause.
4. Breach of the covenants herein may be regarded as a material breach of the contract or purchasing agreement as provided in the Elliott-Larsen Civil Rights Act and City Ordinance 1856.
5. The Contractor will include or incorporate by reference the provisions of the foregoing paragraphs 1 through 4 in every subcontract or purchase order unless exempted by the rules, regulations or orders of the Michigan Civil Rights Commission* and will provide in every subcontract or purchase order that said provision will be binding upon each subcontractor or seller.
6. The Contractor will not preclude a person with a criminal conviction from being considered for employment unless otherwise precluded by federal or state law. (for contracts over \$25,000)

The Elliott-Larson Civil Rights Act, Sec. 202 of Act. No. 453 of 1976 reads in part as follows:

Sec. 202. (1) An employer shall not:

- (a) Fail or refuse to hire, or recruit, or discharge or otherwise discriminate against an individual with respect to employment, compensation, or a term condition or privilege of employment because of religion, race, color, national origin, age, sex, height, weight or marital status.
- (b) Limit, segregate or classify an employee or applicant for employment in a way which deprives or tends to deprive the employee or applicant of an employment opportunity or otherwise adversely affects the status of an employee or applicant because of religion, race, color, national origin, age, sex, height, weight or marital status.
- (c) Segregate, classify or otherwise discriminate against a person on the basis of sex with respect to a term, condition or privilege of employment, including a benefit plan or system.

* Except for contracts entered into with parties employing less than three employees.

APPENDIX B - PREVAILING WAGES

Prevailing wages are applicable to this contract, therefore, rates will apply as follows:

- (XX) Project is funded by City of Kalamazoo monies and is estimated to be in excess of \$100,000.00. The applicable prevailing wage rates are attached.

Specifications for projects in which the City of Kalamazoo is party for construction, alterations and/or repair including painting and decorating of public buildings or public works in or for the City of Kalamazoo and which requires or involves the employment of mechanics and/or laborers shall contain the following provisions stating the minimum wages to be paid the various classes of laborers and mechanics for the project. Prevailing wage rates determined by the U.S. Department of Labor under Davis Bacon and related acts will be used for City of Kalamazoo construction projects.

By the incorporation of prevailing wage rates within this specification, the City of Kalamazoo stipulates that:

- ✓ Contractor or his/her subcontractor shall pay all mechanics and laborers employed directly upon the site of the work, unconditionally and not less than once a week and without subsequent deduction or rebate on any account the full amount, accrued at the time of payment, computed at wage rates as incorporated herein regardless of any contractual relationship which may be alleged to exist between the contractor or subcontractor and such laborers and mechanics;
- ✓ The scale of wages to be paid shall be posted by the contractor in a prominent and easily accessible place at the site of the work;
- ✓ The Prime Contractor and all subcontractors shall submit weekly certified payrolls documenting the hours worked and wages paid by work classification. **NOTE: Contactor shall not include Social Security numbers of employees on certified payrolls.**
- ✓ There may be withheld from the contractor's accrued payments the amount considered necessary by the City's Contracting Official to pay to laborers and mechanics employed by the contractor or any subcontractor on the work for the difference between the rates of wages required by the contract and the rates of wages received by such laborers and mechanics except those amounts properly deducted or refunded pursuant to the terms of the Davis-Bacon Act (USC, Title 40, Sec. 276a) and interpretations thereof.

Special Note: The City's requirements as it relates to prevailing wages **includes a meeting with the City's Purchasing Agent prior to starting work and the submission of weekly certified payrolls by prime contractors and all subcontractors.** The City will monitor certified payrolls, work progress, and conduct interviews with the mechanics and labors employed directly upon the site during the duration of the contract Please contact the Purchasing Department at (269) 337-8020 if you have any questions regarding prevailing wage provision.

The overtime pay to which a laborer or mechanic is entitled under this contract shall be that overtime pay to which he/she is entitled by any agreement made with the contractor or subcontractor or by any applicable provision of law; but in no event shall such amount be less than the prevailing wage in the Kalamazoo community for such overtime.

Revised 4-08



PREVAILING WAGES

BORN COURT WELL 1-7

Bid Reference #: 91244-044.0

May 2025

"General Decision Number: MI20250061 03/14/2025

Superseded General Decision Number: MI20240061

State: Michigan

Construction Type: Heavy

County: Kalamazoo County in Michigan.

Heavy, Includes Water, Sewer Lines and Excavation (Excludes Hazardous Waste Removal; Coal, Oil, Gas, Duct and other similar Pipeline Construction)

Note: Contracts subject to the Davis-Bacon Act are generally required to pay at least the applicable minimum wage rate required under Executive Order 14026 or Executive Order 13658. Please note that these Executive Orders apply to covered contracts entered into by the federal government that are subject to the Davis-Bacon Act itself, but do not apply to contracts subject only to the Davis-Bacon Related Acts, including those set forth at 29 CFR 5.1(a)(1).

<p>If the contract is entered into on or after January 30, 2022, or the contract is renewed or extended (e.g., an option is exercised) on or after January 30, 2022:</p>	<ul style="list-style-type: none"> . Executive Order 14026 generally applies to the contract. . The contractor must pay all covered workers at least \$17.75 per hour (or the applicable wage rate listed on this wage determination, if it is higher) for all hours spent performing on the contract in 2025.
<p>If the contract was awarded on or between January 1, 2015 and January 29, 2022, and the contract is not renewed or extended on or after January 30, 2022:</p>	<ul style="list-style-type: none"> . Executive Order 13658 generally applies to the contract. . The contractor must pay all covered workers at least \$13.30 per hour (or the applicable wage rate listed on this wage determination, if it is higher) for all hours spent performing on that contract in 2025.

The applicable Executive Order minimum wage rate will be adjusted annually. If this contract is covered by one of the Executive Orders and a classification considered necessary for performance of work on the contract does not appear on this wage determination, the contractor must still submit a conformance request.

Additional information on contractor requirements and worker protections under the Executive Orders is available at <http://www.dol.gov/whd/govcontracts>.

Modification Number Publication Date
 0 01/03/2025

1

03/14/2025

CARP0525-006 06/01/2023

	Rates	Fringes
CARPENTER, Includes Form Work....	\$ 28.29	21.42

ELEC0131-006 06/01/2023

	Rates	Fringes
ELECTRICIAN.....	\$ 38.29	19.47

ENGI0325-009 09/01/2024

POWER EQUIPMENT OPERATORS: Underground Construction (Including Sewer)

	Rates	Fringes
POWER EQUIPMENT OPERATOR		
GROUP 1.....	\$ 43.48	25.25
GROUP 2.....	\$ 37.75	25.25
GROUP 3.....	\$ 38.02	25.25
GROUP 4.....	\$ 37.45	25.25

POWER EQUIPMENT OPERATOR CLASSIFICATIONS

GROUP 1: Backhoe/ Excavator, Boring Machine, Bulldozer, Crane, Grader/ Blade, Loader, Roller, Scraper, Trencher (over 8 ft. digging capacity)

GROUP 2: Trencher (8-ft digging capacity and smaller)

GROUP 3: Boom Truck (non-swinging, non- powered type boom)

GROUP 4: Broom/ Sweeper, Fork Truck, Tractor, Bobcat/ Skid Steer /Skid Loader

ENGI0326-025 06/01/2024

EXCLUDES UNDERGROUND CONSTRUCTION

	Rates	Fringes
OPERATOR: Power Equipment		
GROUP 1.....	\$ 47.28	25.25
GROUP 2.....	\$ 43.93	25.25
GROUP 3.....	\$ 41.28	25.25
GROUP 4.....	\$ 39.57	25.25
GROUP 5.....	\$ 39.57	25.25
GROUP 6.....	\$ 33.71	25.25
GROUP 7.....	\$ 31.23	25.25

PAID HOLIDAYS: New Year's Day, Memorial Day, Fourth of July, Labor Day, Thanksgiving Day and Christmas Day.

POWER EQUIPMENT OPERATOR CLASSIFICATIONS

GROUP 1: Crane operator with main boom and jib 400', 300', or 220' or longer.

GROUP 2: Crane operator with main boom and jib 140' or longer, tower crane, gantry crane, whirley derrick

GROUP 3: Backhoe/Excavator; Boring Machine; Bulldozer; Crane; Grader/Blade; Loader; Roller; Scraper; Tractor; Trencher

GROUP 4: Bobcat/Skid Loader; Broom/Sweeper; Fork Truck (over 20' lift)

GROUP 5: Boom truck (non-swinging)

GROUP 6: Fork Truck (20' lift and under for masonry work)

GROUP 7: Oiler

FOOTNOTES:

Crane operator with main boom and jib 300' or longer: \$1.50 per hour above the group 1 rate.

Crane operator with main boom and jib 400' or longer: \$3.00 per hour above the group 1 rate.

IRON0025-011 06/01/2024

	Rates	Fringes
IRONWORKER (REINFORCING).....	\$ 35.00	33.14
IRONWORKER (STRUCTURAL).....	\$ 35.55	33.14

LAB00334-011 09/01/2022

SCOPE OF WORK:

OPEN CUT CONSTRUCTION: Excavation of earth and sewer, utilities, and improvements, including underground piping/conduit (including inspection, cleaning, restoration, and relining)

	Rates	Fringes
LABORER		
(1) Common or General.....	\$ 22.42	12.95
(2) Mason Tender- Cement/Concrete.....	\$ 22.55	12.95
(4) Grade Checker.....	\$ 22.73	12.95
(5) Pipelayer.....	\$ 22.85	12.95

* LAB00355-010 06/01/2024

EXCLUDES OPEN CUT CONSTRUCTION

	Rates	Fringes
LABORER		
Common or General; Grade Checker; Mason Tender - Cement/Concrete.....	\$ 23.34	11.60
Pipelayer.....	\$ 20.34	12.85

PAIN0312-014 06/12/2014

	Rates	Fringes
--	-------	---------

PAINTER

Brush & Roller.....	\$ 21.75	11.94
Spray.....	\$ 22.75	11.94

PLAS0016-020 04/01/2014

Rates Fringes

CEMENT MASON/CONCRETE FINISHER...	\$ 22.31	12.83
-----------------------------------	----------	-------

PLUM0333-026 06/01/2022

Fort Custer

Rates Fringes

PLUMBER.....	\$ 42.29	23.94
--------------	----------	-------

PLUM0357-012 07/01/2020

Excluding Fort Custer

Rates Fringes

PLUMBER.....	\$ 35.20	22.35
--------------	----------	-------

TEAM0007-011 06/01/2024

Rates Fringes

TRUCK DRIVER

Lowboy/Semi-Trailer Truck...	\$ 32.55	.75 + a+b
Tractor Haul Truck.....	\$ 32.30	.75 + a+b

FOOTNOTE:

- a. \$470.70 per week.
- b. \$68.70 daily.

* SUMI2010-059 11/09/2010

Rates Fringes

LABORER: Landscape.....	\$ 12.25 **	0.00
-------------------------	-------------	------

TRUCK DRIVER: Dump Truck.....	\$ 18.00	6.43
-------------------------------	----------	------

TRUCK DRIVER: Off the Road Truck.....	\$ 20.82	3.69
--	----------	------

WELDERS - Receive rate prescribed for craft performing operation to which welding is incidental.
=====

** Workers in this classification may be entitled to a higher minimum wage under Executive Order 14026 (\$17.75) or 13658 (\$13.30). Please see the Note at the top of the wage determination for more information. Please also note that the minimum wage requirements of Executive Order 14026 are not currently being enforced as to any contract or subcontract to which the states of Texas, Louisiana, or Mississippi, including their agencies, are a party.

Note: Executive Order (EO) 13706, Establishing Paid Sick Leave for Federal Contractors applies to all contracts subject to the Davis-Bacon Act for which the contract is awarded (and any solicitation was issued) on or after January 1, 2017. If this contract is covered by the EO, the contractor must provide employees with 1 hour of paid sick leave for every 30 hours they work, up to 56 hours of paid sick leave each year. Employees must be permitted to use paid sick leave for their own illness, injury or other health-related needs, including preventive care; to assist a family member (or person who is like family to the employee) who is ill, injured, or has other health-related needs, including preventive care; or for reasons resulting from, or to assist a family member (or person who is like family to the employee) who is a victim of, domestic violence, sexual assault, or stalking. Additional information on contractor requirements and worker protections under the EO is available at <https://www.dol.gov/agencies/whd/government-contracts>.

Unlisted classifications needed for work not included within the scope of the classifications listed may be added after award only as provided in the labor standards contract clauses (29CFR 5.5 (a) (1) (iii)).

The body of each wage determination lists the classifications and wage rates that have been found to be prevailing for the type(s) of construction and geographic area covered by the wage determination. The classifications are listed in alphabetical order under rate identifiers indicating whether the particular rate is a union rate (current union negotiated rate), a survey rate, a weighted union average rate, a state adopted rate, or a supplemental classification rate.

Union Rate Identifiers

A four-letter identifier beginning with characters other than ""SU"", ""UAVG"", ?SA?, or ?SC? denotes that a union rate was prevailing for that classification in the survey. Example: PLUM0198-005 07/01/2024. PLUM is an identifier of the union whose collectively bargained rate prevailed in the survey for this classification, which in this example would be Plumbers. 0198 indicates the local union number or district council number where applicable, i.e., Plumbers Local 0198. The next number, 005 in the example, is an internal number used in processing the wage determination. The date, 07/01/2024 in the example, is the effective date of the most current negotiated rate.

Union prevailing wage rates are updated to reflect all changes over time that are reported to WHD in the rates in the collective bargaining agreement (CBA) governing the classification.

Union Average Rate Identifiers

The UAVG identifier indicates that no single rate prevailed for those classifications, but that 100% of the data reported for the classifications reflected union rates. EXAMPLE: UAVG-OH-0010 01/01/2024. UAVG indicates that the rate is a weighted union average rate. OH indicates the State of Ohio. The next number, 0010 in the example, is an internal number used in producing the wage determination. The date, 01/01/2024

in the example, indicates the date the wage determination was updated to reflect the most current union average rate.

A UAVG rate will be updated once a year, usually in January, to reflect a weighted average of the current rates in the collective bargaining agreements on which the rate is based.

Survey Rate Identifiers

The ""SU"" identifier indicates that either a single non-union rate prevailed (as defined in 29 CFR 1.2) for this classification in the survey or that the rate was derived by computing a weighted average rate based on all the rates reported in the survey for that classification. As a weighted average rate includes all rates reported in the survey, it may include both union and non-union rates. Example: SUFL2022-007 6/27/2024. SU indicates the rate is a single non-union prevailing rate or a weighted average of survey data for that classification. FL indicates the State of Florida. 2022 is the year of the survey on which these classifications and rates are based. The next number, 007 in the example, is an internal number used in producing the wage determination. The date, 6/27/2024 in the example, indicates the survey completion date for the classifications and rates under that identifier.

?SU? wage rates typically remain in effect until a new survey is conducted. However, the Wage and Hour Division (WHD) has the discretion to update such rates under 29 CFR 1.6(c)(1).

State Adopted Rate Identifiers

The ""SA"" identifier indicates that the classifications and prevailing wage rates set by a state (or local) government were adopted under 29 C.F.R 1.3(g)-(h). Example: SAME2023-007 01/03/2024. SA reflects that the rates are state adopted. ME refers to the State of Maine. 2023 is the year during which the state completed the survey on which the listed classifications and rates are based. The next number, 007 in the example, is an internal number used in producing the wage determination. The date, 01/03/2024 in the example, reflects the date on which the classifications and rates under the ?SA? identifier took effect under state law in the state from which the rates were adopted.

WAGE DETERMINATION APPEALS PROCESS

1) Has there been an initial decision in the matter? This can be:

- a) a survey underlying a wage determination
- b) an existing published wage determination
- c) an initial WHD letter setting forth a position on a wage determination matter
- d) an initial conformance (additional classification and rate) determination

On survey related matters, initial contact, including requests for summaries of surveys, should be directed to the WHD Branch of Wage Surveys. Requests can be submitted via email to davisbaconinfo@dol.gov or by mail to:

Branch of Wage Surveys
Wage and Hour Division

U.S. Department of Labor
200 Constitution Avenue, N.W.
Washington, DC 20210

Regarding any other wage determination matter such as conformance decisions, requests for initial decisions should be directed to the WHD Branch of Construction Wage Determinations. Requests can be submitted via email to BCWD-Office@dol.gov or by mail to:

Branch of Construction Wage Determinations
Wage and Hour Division
U.S. Department of Labor
200 Constitution Avenue, N.W.
Washington, DC 20210

2) If an initial decision has been issued, then any interested party (those affected by the action) that disagrees with the decision can request review and reconsideration from the Wage and Hour Administrator (See 29 CFR Part 1.8 and 29 CFR Part 7). Requests for review and reconsideration can be submitted via email to dba.reconsideration@dol.gov or by mail to:

Wage and Hour Administrator
U.S. Department of Labor
200 Constitution Avenue, N.W.
Washington, DC 20210

The request should be accompanied by a full statement of the interested party's position and any information (wage payment data, project description, area practice material, etc.) that the requestor considers relevant to the issue.

3) If the decision of the Administrator is not favorable, an interested party may appeal directly to the Administrative Review Board (formerly the Wage Appeals Board). Write to:

Administrative Review Board
U.S. Department of Labor
200 Constitution Avenue, N.W.
Washington, DC 20210.

=====

END OF GENERAL DECISION"



SPECIFICATIONS

BORN COURT WELL 1-7

Bid Reference #: 91244-044.0

May 2025

Born Court Well 1-7

City of Kalamazoo
Kalamazoo County, Michigan

May 2025

2220555

APPROVED BY:
THE CITY OF KALAMAZOO

— *John Crandall* — DATE: 05/16/2025

DEPARTMENT OF PUBLIC SERVICES
ASSISTANT CITY ENGINEER

Peter W. Brink
5/15/25

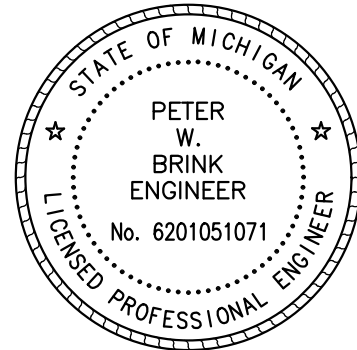

[Intentionally left blank]

TABLE OF CONTENTS

Division 0 – City of Kalamazoo Invitation for Bid Documents

Division 1 – General Requirements

Division 2 – Existing Conditions

Division 9 – Finishes

Division 26 – Electrical

Division 27 – Communications

Division 31 – Earthwork

Division 32 – Exterior Improvements

Division 33 – Utilities

Division 40 – Process Integration

EXHIBITS

Exhibit 1 - City of Kalamazoo Work Practice – Water Facility Enter

APPENDICES

Appendix C Specifications for Excavating, Trenching, and Backfilling for Utilities
 Specifications for Surface Restoration
 City of Kalamazoo - Standard Specifications for Water Main and Service
 Installation - 2021

PLANS

GENERAL REQUIREMENTS

DIVISION 1

TABLE OF CONTENTS

SECTION	TITLE
01 10 00	Summary of Work
01 21 00	Allowances
01 23 00	Alternates
01 31 19	Project Meetings
01 33 00	Submittals
01 51 00	Temporary Utilities
01 57 13	Temporary Erosion and Sediment Control
01 60 00	Materials and Equipment
01 75 00	Starting and Adjusting

PART 1 - GENERAL

1.01 GENERAL

- A. Related Sections: Some Sections of the Specifications (Divisions 1 through 48) may include a paragraph titled "Related Sections." This paragraph is an aid to the Project Manual user and is not intended to include all Sections that may be related. It is the Contractor's obligation to coordinate all Sections whether indicated under "Related Sections" or not.

1.02 SUMMARY OF WORK

- A. The work covered by the Contract Documents consists of improvement to the **Born Court Station No. 2 located at 112 Born Court, Kalamazoo, Michigan**. Included in this work is furnishing all supervision, labor, materials, equipment, activities and related costs necessary for completing the improvements. Work includes but is not limited to:

Salvage and reuse of the existing Born Court Well including providing and installing a new well pump. Also included is all associated equipment, valves, piping, mechanical, electrical, controls, and site work.

- B. The Contractor shall visit the site of the work and shall completely inform himself relative to construction hazards and procedure, labor, and all other conditions and factors, local and otherwise, which would affect execution and completion of the work and its cost. Such considerations shall include the arrangement and condition of the existing structures and facilities, the availability and cost of labor and facilities for transportation, handling and storage of materials and equipment. All such factors shall be properly investigated and considered in the preparation of the Contractor's proposal. There will be no subsequent financial adjustment for lack of such prior information.

- C. The Contractor shall guarantee all equipment and work for one year from the date of substantial completion.

- D. Phasing:

1. The existing **wellhouse is not in service**.
2. Proposed well pump discharge piping will be connected to an existing watermain that is not yet in service.
3. An existing 14-inch watermain connected to the existing wellhouse will be cut, capped and abandoned.
 - a. Prior to cutting the existing 14-inch watermain, isolate it at Burdick Street and tap it with a corporation stop near the location of the proposed caps to verify successful valve operation/watermain shutdown.
 - b. If existing valves provide successful isolation, cut and cap the 14-inch watermain where shown in the Drawings.
 - c. If the existing valves do not provide successful isolation, complete a temporary linestop 40 feet east of the location of the proposed caps and cut and cap the 14-inch watermain where shown in the Drawings. Install precast thrust restraint blocks between the two caps.
4. After completing pump installation and above and below ground piping, Contractor shall be responsible for completing disinfection and bacteria testing of all piping installed

under this contract as well as the 16-inch watermain installed by others from a connection near Stockbridge across from the City of Kalamazoo Central Treatment Plant. The 16-inch installed by others has previously been disinfected and has successful test results, but will be included in this project's disinfection and testing as it has been sitting unused for several months.

Water can be flushed to the new above ground piping by temporarily removing the above ground 8-inch blind flange and installing Contractor provided fittings for flushing. The blind flange with sample tap shall be installed for sampling.

Contractor shall be responsible for dechlorinating flushing water as necessary and properly discharging water without causing any erosion.

1.03 STANDARD SPECIFICATIONS

The specifications as provided in Appendix C are hereby made a part of this contract and are specifically referenced in other Sections of these specifications.

Where a standard construction method or contract procedure is not specifically covered by the Contract Documents or shown on the plan, the most recent edition of the Michigan Department of Transportation (MDOT) Standard Specifications for Construction shall apply. Specific references made in these documents will be abbreviated as follows: MDOT 000.00.

1.04 CONTRACTOR USE OF SITE AND PREMISES

- A. The Contractor may use available space on the City of Kalamazoo property at the 112 Born Court wellhouse as well as the property on the east corner of Crosstown Parkway and Stockbridge (151 W Crosstown Parkway). Limit use of site and premises to allow Owner access to and operation of all existing water pumping and treatment facilities.

The Contractor shall not encumber the site with material and equipment that would interfere with operation.

Contractor shall abide by City ordinance requirements related to noise control.

- B. Access to Site

1. During construction, all roadways, streets and alleys may not be obstructed unless special permission is received from Owner.

- C. Construction Operations: Limited to areas noted on Drawings. Limits of construction shall be confined to property owned by the Owner. Contractor shall coordinate access, site utilization, and work area limits with the Owner.

- D. Time Restrictions for Performing Work: Work shall be performed during normal business hours. No night or weekend or Holiday work allowed unless permission is received from the Owner.

- E. Utility Outages and Shutdowns: Any utility outages required shall be approved in advance by the Owner. Temporary utilities shall be provided by the Contractor to ensure the full functionality of the facility during temporary outages.

- F. The Owner desires to limit tree removals on site during construction of the improvements. Only trees specifically marked "Remove" on the Drawings shall be removed unless specifically authorized by the Owner.

- G. Use of Site for Storage and Field Office: Space for storage and field office for the Contractor is the Contractor's responsibility. Any structures or facilities needed for storage or field office shall be

constructed by the Contractor at Contractor's own expense and no separate payment will be made therefor. The Contractor shall not unreasonably encumber the site with materials and equipment and shall obtain and pay for use of additional storage or work areas needed for operations. The Contractor shall not load structure with weight that will endanger the structure. The Contractor shall move any stored products which interfere with operations of the Owner or other Contractors.

All security requirements for such facilities shall be provided and maintained by the Contractor. The Contractor shall remove any temporary facilities and all surplus materials when there is no further need of them. Each Subcontractor shall be held responsible to the General Contractor for all damages to existing site facilities disturbed through the performance of his work, or in the delivery of materials or equipment for his use, and shall pay all costs in connection with repairing of same. The General Contractor shall be held responsible that all damage be repaired.

- H. During performance of the work, the Contractor shall, at all times, keep the site or sites of the work and adjacent premises as free from material, debris and rubbish as is practical and shall remove it from any portion of the sites, if in the opinion of the Engineer, such material, debris or rubbish constitutes a nuisance or is objectionable.

At the conclusion of the work, all erection plant tools, temporary structures and materials belonging to the Contractor shall be promptly removed from the construction site and he shall remove and promptly dispose of all water, dirt, rubbish or any other foreign substances.

The Contractor shall thoroughly clean all equipment and materials installed by him and shall deliver such materials and equipment undamaged in a bright, clean, polished and new-appearing condition.

Areas of work shall be clean and dust free prior to beginning operation of new equipment.

1.05 WORK SEQUENCE AND COORDINATION

- A. Contractor shall provide all temporary pumping, power, etc necessary as a result of work by the Contractor.
- B. The Contractor shall be responsible for sequencing construction operations in an efficient manner and to minimize the length of service interruptions. Contractors shall coordinate and cooperate with each other such that the necessary work items and dates can be met.
- C. The Contractor shall coordinate construction with the local residents and businesses in the area.
- D. The Contractor may submit a written proposal for changing elements of the sequence of events. Any changes to the sequence of events shall be reviewed and approved by the Owner and Engineer in writing prior to initiation of such by the Contractor.

1.06 PROGRESS SCHEDULE

To enable the work to be laid out and prosecuted in an orderly and expeditious manner, the Contractor shall submit to the Engineer a proposed progress schedule within 20 days after the signing of the Contract. This schedule shall indicate the construction starting date and completion date for each of the various operations to be performed under this Contract. This schedule shall be in the form of a bar chart or of a network diagram showing, in a visual and logical manner, the various work functions or activities necessary to complete the work under this Contract, and the critical relationships between these activities. Required interruption of service to complete activities under this contract shall be addressed in a manner that includes scope of work, preparation tasks prior to service interruption that will minimize down time, estimate of duration of service interruption, and activities that will be requested of the Owner. The Engineer and the Owner will review the proposed progress schedule to determine conformity to the Contract Documents. If such conformity is demonstrated, the Engineer will accept the proposed schedule.

During the course of the Contract, the Contractor shall submit to the Engineer every 30 days or less a revised progress schedule indicating any anticipated change from the original progress schedule. The revised schedule shall include provisions for performing work authorized under approved Change Orders. If the Engineer determines that the modifications in the revised progress schedule are reasonable and that they conform to the Contract Documents, the Engineer will accept the revised schedule.

If the Contractor fails to adhere to the approved progress schedule as revised, he shall promptly adopt such other or additional means and methods of construction as will make up for the time lost, and will assure completion in accordance with such schedule.

Once construction has commenced it shall continue through to completion without interruption.

1.07 PERMITS

- A. General: The Contractor shall obtain all permits necessary for construction of this project not obtained by the Owner. The Contractor shall pay for any charges or bonds required by agencies for permits, inspections or similar charges to construct this project as shown on the Drawings.
- B. Soil Erosion and Sedimentation Control - The Contractor shall submit application and payment and obtain a Soil Erosion and Sedimentation Control permit. Contractor shall meet all requirements of the permit and abide by all applicable rules and regulations as established by the State of Michigan and the local regulating agency in conjunction with Soil Erosion and Sedimentation Control Act (Act 347 P.A. of 1972) as amended. Copies of the state guidelines "Better Environment through Soil Erosion and Sedimentation Control" may be obtained from the local regulating agency.
- C. The Owner will obtain an Act 399 Water Supply System Permit from the Michigan Department of Environment, Great Lakes, and Energy. Contractor shall abide by all relevant requirements of this permit, which will be provided when received.

1.08 STAKING, CONTROLS, MONUMENTS

The Owner will provide control stakes for alignment and grade of the proposed project for buildings and pipelines. The Contractor shall preserve these controls and shall furnish additional intermediate controls to assure accurate line and grade. The Contractor may request staking on up to two (2) separate occasions. Contractor shall be responsible for cost of additional visits or restaking.

The Contractor shall pay for replacement of destroyed controls and benchmarks or monuments.

The Contractor shall exercise proper care in the preservation of all stakes set for their use or the use of the Engineer and if such stakes are damaged, lost or removed by the Contractor's operation, the cost of resetting may be charged to the Contractor. The Contractor shall pay for replacement of destroyed controls and benchmarks or monuments.

Any irregularity in grade and/or line stakes discovered by the Contractor shall be reported to the Engineer for correction before proceeding with the work.

The Contractor shall provide additional methods, materials, or equipment as may be necessary to facilitate laying out, inspecting and constructing the work. The Contractor shall assume full responsibility for all detailed dimensions and elevations measured from the lines, grades and elevations established by the Engineer.

The construction stakes shall be left in place until each phase of the work has been completed and inspected. In the event of discrepancies in the location or grade of the work, the Contractor shall be responsible for making the necessary corrections unless grade stakes are left in place that shows evidence of an error in staking.

1.09 DATUM PLANE

All elevations indicated or specified refer to the NAVD 1988 datum and are expressed in feet and decimal parts thereof, or in feet and inches.

Retrofit activity shall integrate new facilities with existing. Existing facility dimension data was established by field measurement. The Contractor shall field verify actual site conditions.

1.10 BIDDERS RESPONSIBILITY ON UNDERGROUND CONDITIONS

The soil boring logs, as shown on the Drawings, are being furnished to bidders for their convenience and general information only.

Neither the Engineer nor the Owner guarantees the information shown in the boring logs, nor that other materials might not be encountered, nor that the proportions of the various materials shown will not vary from the information shown thereon. The Bidder will be responsible for making his own sub-surface soil investigations and shall make his own determinations therefrom.

The Bidder hereby waives all claims for damages which he may suffer by reason of the inadequacies or discrepancies of the information shown on these soil boring logs and understands that no compensation will be paid to him due to any inadequacy or discrepancy in this data.

1.11 PROTECTION OF EXISTING UTILITIES

- A. The Contractor must comply with Act 174 of 2013, as amended, MCL 460.721 et seq., and all other Laws concerning Underground Utilities. Before performing site Work, all Underground Utilities, lines and cables both public and private must be located and marked. The Contractor shall notify MISS DIG to locate and mark utilities. The Contractor shall be responsible for locating and marking all utilities not otherwise located through the MISS DIG system including private utilities.
- B. Various underground and overhead structures and utilities are shown on the Drawings. The location and dimensions of such structures and utilities, where given, are believed to be reasonably correct, but do not purport to be absolutely so. These structures and utilities are plotted on the Drawings for the information of the Bidders, but information so given is not to be construed as a representation or assurance that such structures will be found or encountered as plotted, or that such information is complete or accurate. Bidders, therefore, shall satisfy themselves by such means as they may deem proper as to the location of all structures and utilities that may be encountered in the construction of the work. Specific utility locations and elevations, where shown on the Drawings, shall be field verified by the Contractor prior to the start of construction.
- C. The Contractor shall notify the utility companies of his schedule and obtain any necessary permits from them.
- D. The Contractor shall pay for any charges by the utility companies for permits, inspections, or similar charges required to construct the project as shown on the Drawings.
- E. In addition, the Contractor shall immediately notify the Owner of any contact with or damage to Underground Utilities. Contractor shall be solely responsible for the safety, protection of, and repairing any damage done to any Work, surface and subsurface structures and utilities at no additional cost.

1.12 PROTECTION OF NATURAL RESOURCES

- A. The Contractor shall take all necessary steps to prevent damage to fish and game habitat and to preserve the natural resources of the State. Construction shall be carried out so as to minimize discharge of damaging material into any stream, lake, or reservoir.

- B. The Contractor shall exercise caution in the discharge of waters from pumps, deep wells, or well point systems, in order that such discharges do not cause erosion, siltation, soil depositions, etc., in sewers, streams or other water courses or drainage structures.
- C. The Contractor shall not permit any sand or debris of any kind to enter the existing ditches, streams, storm sewers or culverts.
- D. The rules and regulations of all work shall comply with Part 31 (Water Resources Protection), Part 301 (Inland Lakes and Streams Act), Part 91 (Soil Erosion), and Part 303 (Wetland Protection) of P.A. No. 451 (Natural Resources and Environmental Protections Act of 1994).

1.13 PROTECTION OF ADJACENT STRUCTURES AND LANDSCAPING

The Contractor shall be entirely responsible for all damage to water pipes, electric conduits or cables, drains, sewers, gas mains, poles, telephone and telegraph lines, railroad bridges and tracks, streets, pavements, sidewalks, curbs, fences, street and highway bridges and culverts, building foundations, retaining walls or other structures of any kind met with during the progress of the work, and shall be liable for damages to public or private property resulting therefrom.

The cost of protection, replacement in their original positions and conditions or payment for damages thereto of pipe lines and structures affected by the work and the removal, relocation and rebuilding of pipe lines and structures called for on the Drawings or specified shall be deemed included in the contract lump sum. No additional payment will be made therefor.

The Contractor shall, at all times in performance of the work, employ approved methods and exercise reasonable care and skill so as to avoid unnecessary delay, injury, damage or destruction of public utility installations and structures; and shall, at all times in the performance of the work, avoid unnecessary interference with, or interruption of, public utility services, and shall cooperate fully with the Owner and utility owners thereof to that end.

All pipe lines carrying liquid shall be adequately protected from freezing. All fire hydrants, valves and appurtenances on the various water systems shall be maintained in service, and temporary connections shall be provided where necessary.

All trees and shrubs, except those shown to be removed, shall be adequately protected by the Contractor with boxes or otherwise. No excavated materials shall be placed so as to injure such trees or shrubs. Trees or shrubs destroyed by negligence of the Contractor or his employees shall be replaced by him with new stock of similar size and age, at the proper season and at the sole expense of the Contractor. Trees larger than 3 inch caliper shall be replaced with 2-1/2 inch to 3 inch caliper hardwood trees of species approved by the Engineer.

Beneath trees or other surface structures, where possible, pipelines may be built in short tunnels, backfilled with excavated materials, except as otherwise specified, or the trees or structures carefully supported and protected from damage.

Any fence, or part thereof, that is damaged or removed during the course of the work shall be replaced or repaired by the Contractor and shall be left in as good a condition as before the start of work. The manner in which the fence is repaired or replaced and the materials used in such work shall be subject to the approval of the Engineer. The cost of all labor, materials, equipment, and work for the replacement or repair of any fence shall be deemed included in the appropriate Contract Item or Items, or if no specific Item is provided therefor, as part of the overhead cost of the work, and no additional payment will be made therefore.

1.14 ALLOWANCES

Provide an allowance of \$25,000 for completing a line stop on the existing 14-inch watermain if the watermain cannot be isolated using existing valves. In the case the linestop is needed, the allowance shall

also be utilized to properly compact backfill and restore the pavement to match existing. Pavement shall be neatly sawcut in a square or rectangular shape prior to restoration.

See Section 01 21 00 Allowances for further detail.

1.15 WARRANTY

The Contractor shall warranty and guarantee all equipment and work for a minimum of one year from the dates of substantial completion. Greater warranty duration may be required by the project specifications for specific equipment and/or work.

1.16 SAFETY

The Contractor is solely responsible for safety in accordance with the General Conditions.

PART 2 - PRODUCTS

*** Not Used ***

PART 3 - EXECUTION

*** Not Used ***

END OF SECTION

PART 1 - GENERAL

1.01 SUMMARY

- A. Administrative and procedural requirements governing handling and processing of Allowances.

1.02 ALLOWANCES

- A. It is intended that the work covered by these Cash Allowances will be done within this Contract under the supervision of the General Contractor and/or Subcontractors. All outside expenses, overhead and profit connected with the work contemplated in these Allowances shall be included in the Contract Base Bid Price. If actual work covered by an allowance differs in cost from the allowance, a Change Order shall be processed to adjust for the difference. No mark-up for the General Contractor or Subcontractors shall be included in such Change Order.

1.03 SELECTION AND PURCHASE

- A. At the earliest feasible date after Contract award, advise the Engineer of the date when the final selection and purchase of each product or system described by an Allowance must be completed in order to avoid delay in performance of the work.
- B. When requested by the Engineer, obtain proposals for each Allowance for use in making final selections; include recommendations that are relevant to performance of the work.
- C. Purchase products and systems as selected by the Engineer from designated supplier.

1.04 SUBMITTALS

- A. Submit under the provisions of Section 01 33 00 – “Submittals.”
- B. Proposals for installation and purchase of products or systems included in Allowances.
- C. Invoices or delivery slips to indicate actual costs and quantities of materials delivered to the site for use in fulfillment of each allowance.

1.05 UNUSED MATERIALS

- A. Return unused materials to the manufacturer or supplier for credit to the Owner, after installation has been completed and accepted.
- B. Where it is not economically feasible to return unused material for credit and when requested by the Engineer, prepare unused material for the Owner's storage, and deliver to the Owner's storage space as directed. Otherwise, disposal of excess material is the Contractor's responsibility.

PART 2 - PRODUCTS

Not Applicable.

PART 3 - EXECUTION

3.01 INSPECTION

- A. Inspect products covered by an Allowance promptly upon delivery for damage or defects.

3.02 PREPARATION

- A. Coordinate materials and their installation for each Allowance with related materials and installations to ensure that each Allowance item is completely integrated and interfaced with related construction activities.

3.03 LIST OF ALLOWANCES

- A. Temporary Linestop and Associated Restoration— See Section 01 10 00.

END OF SECTION

PART 1 - GENERAL

- 1.01 GENERAL: Project meetings for coordination of Contractor activity with the operation of the water system will be held as detailed in this section with additional meetings as requested by the Owner or Engineer, as dependent on the staging requirements for specific portions of the project. Meetings will be held at a location chosen by the Owner.
- 1.02 PRE-CONSTRUCTION MEETING
- A. Schedule: Meeting shall be prior to the start of work at a time and place designated by the Engineer. Contractor shall be required to attend with major Subcontractors.
- 1.03 PROGRESS MEETINGS
- A. Schedule: Meetings will be scheduled once every two weeks at a time and place designated by the Engineer. Contractor shall attend all progress meeting and shall have Subcontractors attend as relevant to the current status of the project.

PART 2 - PRODUCTS

*** Not Applicable ***

PART 3 - EXECUTION

*** Not Applicable ***

END OF SECTION

PART 1 - GENERAL

1.01 SECTION INCLUDES

- A. Data to be furnished by the Contractor.

1.02 CONSTRUCTION PROGRESS SCHEDULE

- A. See requirements for Contractor submission of a construction progress schedule in Section 01 10 00 – “Summary of Work.”

1.03 SHOP DRAWINGS, PRODUCT DATA, AND SAMPLES

- A. General: Where required by the Specifications, the Contractor shall submit descriptive information which will enable the Engineer to advise the Owner whether the Contractor's proposed materials, equipment, or methods of work are in general conformance to the design concept and in compliance with the Drawings and Specifications. The information to be submitted shall consist of drawings, specifications, descriptive data, certificates, samples, test results and such other information, all as specifically required in the Specifications. Shop drawings shall be in accordance with the General Conditions and Supplementary Conditions and the requirements outlined herein.

- B. Submittal Content and Format: Submittals shall be numbered consecutively and distinctly present the following:

1. All working and erection dimensions.
2. Arrangements and sectional views.
3. Necessary details, including complete information for making connections between work under this Contract and work under other Contracts.
4. Electrical wiring connections between all equipment furnished under the Contract, including all internal wiring between internal components of equipment and controls.
5. Kinds of materials and finishes.
6. Parts lists and description thereof.
7. Drawings for mechanical and electrical equipment shall present, where applicable, such data as dimensions, weight, and performance characteristics. These data shall show conformance with the performance characteristics and other criteria incorporated in the Contract Documents.

- C. Contractor Responsibility

1. Contractor shall be responsible for the accuracy and completeness of the information contained in each submittal and shall assure that the material, equipment or method of work shall be as described in the submittal. The Contractor shall verify that the material and equipment described in each submittal conform to the requirements of the Specifications and Drawings. If the information shows deviations from the Specifications or Drawings, the Contractor shall insure that there is no conflict with other submittals and notify the Engineer in each case where submittal may affect the work of another Contractor or the Owner. The Contractor shall insure coordination of submittals among the related crafts and Subcontractors.
2. The Contractor shall be responsible to check and verify all field measurements, all dimensions on shop and setting drawings and all schedules required for the work of all the various trades.
3. The Contractor may authorize in writing a material or equipment supplier to deal directly with the Engineer or with the Owner with regard to a submittal. These dealings shall be limited to contract interpretations.

4. The Contractor shall stamp each submittal with stamp, initialed and signed, certifying to review of the submittal by the Contractor, verification of field measurements and compliance with Contract Documents.
- D. Transmittal Procedure
1. Submittals shall be submitted promptly in accordance with dates in proposals, approved schedules and in such sequence that there is no delay in the Work or the work of any other Contractor. Submittals may be submitted by mail or electronically per the requirements listed below.
 2. Submittals regarding material and equipment shall be accompanied by clear identification of the equipment and any variations from these Specifications.
 3. A unique number, sequentially arranged, shall be noted on the transmittal form accompanying each item's submittal. Original submittal numbers shall have the following format "XXX-Y; where "XXX is the originally assigned submittal number, and "Y" is a sequential letter assigned for resubmittals, i.e., A, B, or C being the 1st, 2nd and 3rd resubmittals, respectively. Submittal 025-B, for example, is the second resubmittal of submittal 25.
- E. Electronic Transmittal Procedure – Submittals shall be submitted electronically via the Prein&Newhof Plan Room in accordance with the above “Transmittal Procedure” requirements as well as the following requirements and procedures.
1. Contractor shall be given a Login ID and Password to the Prein&Newhof Plan room. The website for the Prein&Newhof Plan Room is <http://www.preinnewhof.com/plan-room/>.
 2. Upon logging into the website, the Contractor will have access to a project folder labeled with the name of the Owner and Project. This folder will only be accessible to the Contractor, the Owner, and the Engineer.
 3. Login and password will not be provided to Subcontractors. If the Contractor provides their login information to their Subcontractors, the Contractor assumes responsibility for the Subcontractor’s actions.
 4. The Contractor may request automatic notifications by email of an “Upload” of both submitted and reviewed documents.
 5. Within the “Project Folder” there will be a “To Be Reviewed” folder and a “Reviewed” Folder. Contractor shall upload submittals in PDF format to the “To Be Reviewed” subfolder. The time and date of the upload will be logged and automatic email notifications will be sent.
 6. All submittals shall be prepared in accordance with this Section 01 33 00 of the specifications. Electronic submittals shall have the following naming format:

Submittal Number – Specification Section – Description.pdf

For example –001-033000-Concrete Mix Design.pdf

A letter shall be added after the submittal number for resubmittals. For example, 001B-033000-Concrete Mix Design.pdf would be the second resubmission.
 7. Within 15 days, reviewed submittals will be posted in the “Reviewed” folder. Automatic email notifications of the upload will be sent.
 8. The Engineer will update the “Shop Drawing Status Log” and post it in the Project Folder as submittals are received, where it will be accessible by the Owner, Contractor, and Engineer.
 9. Contractor shall submit any submittal requiring an Engineer’s seal as a hard copy. In addition, all submittals with an original size greater than 11 inches by 17 inches shall be submitted as a hard copy. All hard copy submittals shall also be submitted electronically.
- F. Deviation from Contract: If the Contractor proposes to provide material or equipment which does not conform to the Specifications and Drawings, he shall indicate so under "deviations" on the

transmittal form accompanying the submittal copies. Contractor shall prepare reason for a change, including cost differential, and request a change order to cover the deviations.

- G. Submittal Completeness: Submittals which do not have all the information required to be submitted, including deviations, are not acceptable and will be returned without review. Submittals which do not clearly identify specified product and relevant data, and submittals containing non-project specific data, will be rejected.
- H. Review Procedure
1. When the contract documents require a submittal, the Contractor shall submit five (5) copies of all submittal data (or one (1) electronic copy if submitting electronically), of which two (2) copies will be retained by the Engineer. For samples this number may vary. For samples, submit the number stated in each Specifications Section.
 2. If the review indicates that the material, equipment or work method is in general conformance with the design concept and complies with the Drawings and Specifications, submittal copies will be marked "NO EXCEPTIONS TAKEN". In this event the Contractor may begin to implement the work method or incorporate the material or equipment covered by the submittal.
 3. If the review indicates limited corrections are required, submitted copies will be marked "FURNISH AS CORRECTED". The Contractor may begin implementing the work method by the submittal in accordance with the noted corrections. Where submittal information will be incorporated in Operation and Maintenance data, a corrected copy shall be provided.
 4. If the review reveals that the submittal is insufficient or contains incorrect data, submitted copies will be marked "REVISE AND RESUBMIT". Except at its own risk, the Contractor shall not undertake work covered by this submittal until it has been revised, resubmitted and returned marked either "NO EXCEPTIONS TAKEN" or "FURNISH AS CORRECTED".
 5. If the review indicates that the material, equipment or work method is not in general conformance with the Drawings and Specifications, copies of the submittal will be marked "REJECTED". Submittals with deviations which have not been identified clearly may be rejected. Except at its own risk the Contractor shall not undertake the work covered by such submittals until it has been revised, resubmitted and returned marked either "NO EXCEPTIONS TAKEN" or "FURNISH AS CORRECTED".
 6. If the review indicates that the material or equipment is not from an acceptable manufacturer, as indicated in the Specifications, copies of the submittal will be marked "REJECTED". Except at its own risk, the Contractor shall not undertake the work covered by such submittals until it has been revised, resubmitted and returned marked either "NO EXCEPTIONS TAKEN" or "FURNISH AS CORRECTED".
 7. If the review indicates "ACKNOWLEDGED RECEIPT", the submittal under review has been appropriately noted and filed. No further action is required for a submittal so noted.
 8. If the review indicates "ON HOLD", the submittal is being held in the office of the Engineer pending the submittal of additional information, etc. so that the review can be completed. No further action on the submittal shall be taken until the information needed has been received and the submittal is returned marked either "NO EXCEPTIONS TAKEN" or "FURNISH AS CORRECTED".
- I. Effect of Review of Contractor's Submittal
1. Contractor shall furnish required Shop Drawing and Sample submittals with sufficient accuracy to obtain required approval of an item with no more than two resubmittals. Engineer will record Engineer's time for reviewing a third or subsequent resubmittal of a Shop Drawing or Sample, and Contractor shall be responsible for Engineer's charges to Owner for such time. Owner may impose a set-off against payments due Contractor to secure reimbursement for such charges. Recovery of the administrative and review costs will be discussed prior to completing review of all resubmittals as the project progresses.

2. Review of Drawings, methods of work, or information regarding materials or equipment the Contractor proposes to provide, shall not relieve the Contractor of its responsibility for errors therein and shall not be regarded as an assumption of risks or liabilities by the Engineer or the Owner, or by an officer or employee thereof, and the Contractor shall have no claim under the contract on account of the failure, or partial failure, of the method of work, material, or equipment so reviewed.
3. Review of Drawings also shall not relieve the Contractor of responsibility for the proper fitting and construction of the work nor for the furnishing of materials or work required by the Contract and not indicated on the Drawings.
4. A mark of "NO EXCEPTIONS TAKEN" or "FURNISH AS CORRECTED" shall mean that the Owner has no objection to the Contractor, upon its own responsibility, using the plan or method of work proposed, or providing the materials or equipment proposed.

1.04 LIST OF SHOP DRAWING SUBMITTALS

A. Requirements

1. Within two (2) weeks after Notice of Award, the Contractor shall submit for review by the Engineer an anticipated list of shop drawing submittals and submittal dates. If more than one shop drawing submittal is anticipated for a specification section, the Contractor shall identify what will be included in each submittal.

1.05 OPERATION AND MAINTENANCE DATA

A. Requirements

1. Compile product data for all equipment and associated controls systems furnished and installed under this Contract. Provide all necessary information for Owner's operation and maintenance of products furnished.
2. Prepare data in the form of an instructional manual for use by Owner's personnel. Prepare three (3) copies or complete sets compiled, bound in hard stock, and indexed.
3. A USB drive shall be provided of the entire manual in electronic, PDF, format. The electronic PDF shall include suitable bookmarks by section for ease of navigation.
4. The manuals shall include detailed operation and maintenance instructions for all equipment, the name and phone number of the manufacturer, and a complete parts list.
5. Submittal of operation and maintenance manuals shall be prior to final payment request.
6. Each hard copy of the manual shall be prepared and arranged as follows:
 - a. One hard copy of all approved shop drawings and diagrams for all equipment furnished. If the Contractor originally submitted the shop drawings electronically, a hard copy of each shall be printed and provided by the Contractor in each O&M manual. All sheets larger than 8-1/2 by 11 inches shall be folded to 8-1/2 by 11 inches.
 - b. One copy of each manufacturer's operation, lubrication, maintenance instructions and spare parts list for all equipment and controls furnished. All equipment operating, lubrication and maintenance instructions and procedures and parts lists shall be furnished on 8-1/2 by 11 inch commercially printed typed forms. Such forms shall include equipment name, serial number and other identifying references.
 - c. One valve schedule, giving the valve number, location, fluid and fluid destination for each valve installed, prepared on 8-1/2 by 11 inch printed or typed forms as specified. All valves in the same piping system shall be grouped together in the schedule. A sample of the valve numbering system to be used will be furnished by the Engineer.
 - d. List of electrical relay settings and control and alarm contact settings.
 - e. Electrical interconnection wiring diagram for equipment furnished including all control and lighting systems.

- f. Each copy of the manual shall be assembled in one or more binders, each with title page, typed table of contents, and heavy section dividers with copper reinforced holes and numbered plastic index tabs. Each manual shall be divided into sections paralleling the Special Specifications equipment specifications. Binders shall be 3-ring, hard-back type. All data shall be punched for binding and composition and printing shall be arranged so that punching does not obliterate any data. The cover and binding edge of each manual shall have the project title and manual title printed thereon, all as approved by Engineer.
 - g. Where more than one binder is required they shall be labeled Vol. 1, Vol. 2, and so on. The table of contents for the entire set, identified by volume number, shall appear in each binder.
- 7. When the work reaches 80 percent completion, the Contractor shall submit to the Engineer one (1) electronic copy of the Operation and Maintenance Manual with all specified material that is available at that time. The submittal shall accompany the Contractor's partial payment request for the specified completion. Manual shall be complete prior to request for final payment.
 - 8. The costs of the Operation and Maintenance Manual shall be included in the Contract Price and no separate payment will be made therefor.

1.06 RECORD DOCUMENTS

A. Requirements

- 1. The Contractor shall maintain on the construction site a minimum of one (1) complete set of contract documents amended by "RED LINE" or highlight inclusion to reflect the most immediate status methods, materials, and locations and routings of construction. Supplementary sketches shall be included, if necessary, to clearly indicate all work as constructed.
- 2. At conclusion of work, the Contractor shall submit to the (Engineer) one (1) complete amended record set of these site documents.
- 3. Submittal shall be prior to final payment.
- 4. Failure of the Contractor to maintain an up-to-date set of Record Drawings on the project site shall be reason to withhold payments.

PART 2 - PRODUCTS

*** Not Used ***

PART 3 - EXECUTION

*** Not Used ***

END OF SECTION

PART 1 - GENERAL

1.01 GENERAL

- A. This section covers provision of temporary utilities by the Contractor or Owner during the Work.

1.02 TEMPORARY SERVICES

- A. Construction Water: The Contractor must make his own arrangements for obtaining water.
- B. Power and Pumping Equipment: The Contractor is responsible for power needs during pump installation and any temporary pumping equipment needed for testing.
- C. The Electrical Subcontractor shall be responsible for, and include in his bid price, the cost of: wiring for lighting and power outlets in areas where lighting and power source is not ample as determined by the General Contractor or Engineer; temporary connections for motors, pumps, burners, etc. at the direction of the Engineer where heating, ventilation, or other equipment testing is required during construction; and removal of all temporary service items at the end of the project.
- D. Temporary Sanitary Facilities: The General Contractor shall provide temporary facilities for use of all workers on the project. Maintain in clean, sanitary condition and remove same, and all contents upon completion of the work.

PART 2 - PRODUCTS

*** Not Used ***

PART 3 - EXECUTION

*** Not Used ***

END OF SECTION

PART 1 - GENERAL

1.01 DESCRIPTION

- A. This Section includes the work required to provide and maintain temporary soil erosion and sedimentation control.

1.02 JOB CONDITIONS

- A. Scheduling: Clean-up shall occur within one week after erosion control measures are no longer required.

1.03 SUBMITTALS

- A. Submit under provisions of Section 01 33 00 – “Submittals.”
- B. Operational Data: Contractor shall submit a plan for the control of soil erosion and sedimentation to the local agency regulating soil erosion and sedimentation. Plan shall comply with the Soil Erosion and Sedimentation Control permit obtained by the Contractor.

PART 2 - PRODUCTS

2.01 MATERIALS

- A. Materials used for temporary erosion and sedimentation control shall be approved by the regulating agency.

PART 3 - EXECUTION

3.01 PERFORMANCE

- A. General: Abide with all applicable rules and regulations as established by the State of Michigan and the local regulating agency in conjunction with Part 91 Soil Erosion and Sedimentation Control of the Natural Resources and Environmental Protection Act, 1994 PA 451, as amended. Copies of the state guidelines "Better Environment through Soil Erosion and Sedimentation Control" may be obtained from the local regulating agency.
- B. Sediment Removal: Take such steps as are necessary to assure the retention and removal of any sediment which enters a drainage system along the construction route before said system discharges into a stream, pond, or lake.
- C. Soil Erosion and Sedimentation Control Measures: Contractor shall obtain a Soil Erosion and Sedimentation Control Permit from the City of Kalamazoo. Furnish, install and maintain soil erosion and sedimentation control measures in accordance with the Soil Erosion and Sedimentation Control Permit and any additional measures as needed to prevent any sediment from entering surface water.
 - 1. Maintain controls during non-working hours and during working hours if weather so requires.
 - 2. Remove silt or solids retention at control structures following construction.
 - 3. Contractor shall be responsible for the degree of control required, subject to the Permit requirements.

END OF SECTION

PART 1 - GENERAL

1.01 MATERIALS AND EQUIPMENT:

- A. Materials and equipment incorporated into the Work:
 - 1. Shall conform to applicable specifications and standards.
 - 2. Shall comply with size, make, type and quality specified or as specifically approved by the Engineer.
 - 3. Manufactured and Fabricated Products.
 - a. Design, fabricate and assemble in accord with the best engineering and shop practices.
 - b. Manufacture like parts of duplicate units to standard sizes and gages to be interchangeable.
 - c. Two or more items of the same kind shall be identical, by the same manufacturer.
 - d. Products shall be suitable for service conditions.
 - e. Equipment capacities, sizes and dimensions shown or specified shall be adhered to unless variations are specifically approved in writing.
 - 4. Do not use material or equipment for any purpose other than that for which it is designed or specified.

1.02 MANUFACTURER'S INSTRUCTIONS:

- A. When Contract Documents, require that installation of work shall comply with manufacturer's printed instructions, obtain and distribute copies of such instructions to parties involved in the installation, including two sets to the Engineer.
 - 1. Should job conditions or specified requirements conflict with manufacturer's instructions, consult with Engineer for further instructions.
- B. Handle, install, connect, clean, and condition and adjust products in strict accord with such instructions and in conformity with specified requirements.
- C. Perform work in accord with manufacturer's instructions. Do not omit any preparatory step or installation procedures unless specifically modified or exempted by Contract Documents.

1.03 TRANSPORTATION AND HANDLING:

- A. Arrange deliveries of products in accord with construction schedules; coordinate to avoid conflict with work and conditions at the site.
 - 1. Deliver products in undamaged condition, in manufacturer's original containers or packaging with identifying labels intact and legible.
 - 2. Immediately upon delivery, inspect shipments to assure compliance with requirements of Contract Documents and approved submittals and that products are properly protected and undamaged.
- B. Provide equipment and personnel to handle products by methods to prevent soiling or damage to products or packaging.

1.04 STORAGE AND PROTECTION:

- A. Store products in accord with manufacturer's instructions, with seals and labels intact and legible.
 - 1. Store products subject to damage by the elements in weather tight enclosures.
 - 2. Maintain temperature and humidity within the ranges required by manufacturer's instructions.
- B. Arrange storage in a manner to provide easy access for inspection. Make periodic inspections to assure that products are maintained under specified conditions and free from damage or deterioration.

1.05 SUBSTITUTIONS/ALTERNATE EQUIPMENT:

- A. Where materials and equipment items are identified in the Drawings or specifications by manufacturer's name or catalog number, bids shall be based on the products of one of the manufacturers so named or added thereto by addendum during the bidding period. All cost associated with utilizing equipment provided by other Manufacturers shall be included in the add or deduct including all building, electrical, mechanical or any other changes necessary to install the equipment. In addition, Contractor shall be responsible for reimbursing Owner for all engineering and design related to contract modifications necessary to utilize alternate equipment.
- B. Documentation for alternate equipment must be provided as detailed in this section. Review of documentation will be completed by the Engineer and Owner after the bid.
- C. Required documentation for substitutions/alternate equipment must be received by the Engineer not later than 10 days prior to bid for approval or rejection via an Addendum. This information will be required from each bidder who submitted one of the three lowest base bids.
- D. A request for a substitution/proposed alternate equipment constitutes a representation that the Contractor has investigated and determined the proposed product is equal to, or superior in all respects to that specified.
- E. The Contractor shall coordinate the installation of an accepted substitution into the Work and make the Work complete in all respects.
- F. The Engineer shall be the judge of the acceptability of the proposed substitutions.
- G. Requests for substitutions shall be submitted on the accompanying form. In addition to the form, supporting documentation shall be submitted providing technical details of the equipment for this application including complete equipment drawings and scope of supply, review of the specifications including any proposed deviations from it, manufacturer's company history, financial ability of the manufacturer, similar installations of the proposed equipment with reference information including dates of service and contact phone numbers, and any other information deemed necessary by the Engineer for a thorough review. Contractor shall include a complete and detailed list describing all deviations where proposed equipment differs from this specification.

PART 2 - PRODUCTS

*** Not Applicable ***

PART 3 - EXECUTION

*** Not Applicable ***

**APPLICATION FOR APPROVAL OF SUBSTITUTE
MATERIAL/EQUIPMENT**

<u>Material/Equipment</u>	<u>Manufacturer</u>	<u>Model No. Certificate No. or Other Description</u>
_____	_____	_____
	_____	_____
	_____	_____

Proposed Substitute Material/Equipment:

<u>Material/Equipment</u>	<u>Manufacturer</u>	<u>Model No. Certificate No.</u>
_____	_____	_____

Approval of Substitution _____
Contractor _____ Date _____

Not Approved _____
Engineer _____ Date _____

END OF SECTION

PART 1 - GENERAL

1.01 GENERAL

- A. Prior to Substantial Completion, Contractor shall conduct startup and adjustment of all portions of the work to provide a fully functional Type 1 drinking water well pump. All equipment provided shall be subject to the requirements of this section and further requirements in each section where specific equipment is specified.

PART 2 - PRODUCTS

*** Not Used ***

PART 3 - EXECUTION

3.01 MANUFACTURER'S SERVICE ENGINEER

Contractor shall furnish the services of a competent Manufacturer's Service Engineer, if necessary during construction. A Manufacturer's Service Engineer shall be on the site at the time of initial operation of the manufacturer's equipment and must approve the installation before it is placed into service.

3.02 PERFORMANCE TEST AND TRIAL OPERATION

Performance tests of the new facilities will be required and will be made in the presence of the Owner, Contractor, and Engineer. All areas where work has been performed shall be thoroughly cleaned before beginning any performance tests. Operating personnel and power will be provided by the Owner. If any part of the equipment does not meet specifications, the Contractor shall correct the situation to the approval of the Engineer. The Contractor shall provide personnel and bear all costs of correcting any malfunctions in the work under this Contract.

A two week trial operation period shall be conducted for each system component. Training of water treatment plant and water distribution system personnel shall be conducted as requested by the Owner during the performance test and trial operation period. The performance test will be considered complete when the Contractor has corrected any malfunctions in the work and the Owner indicates the test has been completed to his satisfaction. Equipment testing and performance testing shall be conducted as construction proceeds.

END OF SECTION

Project Name: Born Court Well 1-7
Project Number: 2220555

EXISTING CONDITIONS
DIVISION 2
TABLE OF CONTENTS

SECTION	TITLE
02 41 00	Demolition

PART 1 - GENERAL

1.01 SUMMARY

- A. The work covered by this section consists of furnishing all supervision, labor, materials, and equipment necessary to demolish all specified structures, surface improvements, and underground utilities shown in the Drawings, and to remove debris from the site in accordance with all federal, state and local regulations.
- B. This Section requires demolition and abandonment of site piping, and demolition, removal and off-site disposal of building and treatment unit materials, as shown in the Drawings.

1.02 SUBMITTALS

- A. Submit under provisions of Section 01 33 00 – “Submittals.”
- B. Contractor shall propose a schedule of operations including coordination for shutoff, capping, and continuation of utility services as required.
 - 1. Provide detailed sequence of demolition and removal work to ensure uninterrupted progress of Owner’s operations.

1.03 JOB CONDITIONS

- A. The bidder shall be responsible for inspecting the site of the proposed work and to determine for himself all conditions under which he will be obligated to work. It is also expected that the bidder will obtain firsthand information concerning the available facilities for receiving, transporting, disposing, handling and storing demolished equipment and materials, and concerning other local conditions that may affect the work.
- B. Existing Plans: Available plans from previous construction activities issued in 1966 are available for reference in the Prein&Newhof Plan Room (<http://www.preinnewhof.com/plan-room/>). These plans are for general information purposes only and are not guaranteed to represent current or as constructed conditions.
- C. Occupancy: Structures to be demolished will be vacated and use discontinued prior to start of work.
- D. Condition of Structures: Owner assumes no responsibility for actual condition of structures to be demolished.
 - 1. Conditions existing at time of inspection for bidding purpose will be maintained by Owner insofar as practicable. However, variations within structure may occur due to Owner's removal and salvage operations prior to start of demolition work.
 - 2. The Contractor is responsible to perform site investigation as required to determine the actual amount of work required to achieve the requirements of this specifications.
- E. Salvaged Materials: Items of salvable value to Contractor not designated to be turned over to the Owner may be removed from structure as work progresses. Transport salvaged items from site as they are removed.
 - 1. Storage or sale of removed items will not be permitted on site.

- F. Explosives: Use of explosives will not be permitted.
- G. Traffic: Conduct demolition operations and removal of debris to ensure minimum interference with roads, streets, walks, and other adjacent occupied and used facilities.
 - 1. Do not close or obstruct streets, walks, or other occupied or used facilities without permission from authorities having jurisdiction. Provide alternate routes around closed or obstructed traffic ways if required by governing regulations.
- H. Protections: Ensure safe passage of persons around area of demolition. Conduct operations to prevent damage to adjacent buildings, structures, and other facilities and injury to persons.
 - 1. Provide interior and exterior shoring, bracing, or support to prevent movement, settlement, or collapse of structures to be demolished and adjacent facilities to remain.
- I. Damages: Promptly repair damages caused to adjacent facilities by demolition operations.
- J. Utility Services: Maintain existing utilities indicated to stay in service and protect against damage during demolition operations.
 - 1. Do not interrupt existing utilities serving occupied or used facilities, except when authorized in writing by authorities having jurisdiction. Provide temporary services during interruptions to existing utilities, as acceptable to governing authorities.
- K. Utility Services: Do not start demolition work until utility disconnections have been completed and verified in writing.
- L. Comply with requirements of NFPA 241, "Safeguarding Construction, Alteration, and Demolition Operations."
- M. Demolition includes all work necessary for proper removal and disposal of fluorescent tubes and ballasts and mercury switches, and removal and proper disposal of reinforced concrete, masonry steel, piping, equipment, electrical facilities, and any other materials or equipment shown or specified to be removed. As part of this contract, it shall be the Contractor's responsibility to characterize, remove and properly dispose of these items in accordance with all applicable laws and regulations.
- N. Mechanical and Electrical trades shall remove equipment, piping, conduit, and other items pertaining to their respective trades. This shall include temporary removal and reinstallation where necessary.

PART 2 - PRODUCTS

*** Not Used ***

PART 3 - EXECUTION

3.01 DEMOLITION

- A. Pollution Controls: Use water sprinkling, temporary enclosures, and other suitable methods to limit dust and dirt rising and scattering in air. Comply with governing regulations pertaining to environmental protection.
 - 1. Do not use water when it may create hazardous or objectionable conditions such as ice, flooding, and pollution.

2. All work where applicable shall conform to the State of Michigan Soil Erosion and Sedimentation Part 91, Act 451 of the Public Acts of 1994, as amended and related ordinances.
- B. Clean adjacent structures and improvements of dust, dirt, and debris caused by demolition operations. Return adjacent areas to condition existing prior to start of work.
- C. Building Demolition: See the Drawings for a description of the structures to be demolished. Unless otherwise noted, all structures or portions of structures specified to be demolished shall be removed in their entirety, including all contents and associated outdoor equipment not intended to be salvaged by the Owner. Removal shall take place according to the phasing described in the Contract Documents.
- Use such methods as required to complete work within limitations of governing regulations.
1. Small structures may be removed intact when acceptable to Engineer and approved by authorities having jurisdiction.
 2. Proceed with demolition in systematic manner, from top of structure to ground.
 3. Demolish concrete and masonry in small sections.
 4. Remove structural framing members and lower to ground by hoists, derricks, or other suitable methods.
 5. Break up and remove concrete slabs-on-grade, unless otherwise shown to remain.
 6. Locate demolition equipment throughout structure and remove materials so as to not impose excessive loads to supporting walls, floors, or framing.
- D. Below-Grade Construction: Demolish and remove entire foundation walls and footings and other below-grade construction unless specifically indicated otherwise.
- E. Filling Voids: Completely fill below-grade areas and voids resulting from demolition of structures.
1. No demolition debris may be placed in below-grade areas or voids resulting from demolition of structures.
 2. Use granular MDOT Class II fill.
 3. Prior to placement of fill materials, ensure that areas to be filled are free of standing water, frost, frozen material, trash, and debris.
 4. Place fill materials in horizontal layers not exceeding 12 inches in loose depth. Compact each layer at optimum moisture content of fill material to density equal to original adjacent ground, but not less than 95 percent density when tested in accordance with ASTM D1556.
 5. After fill placement and compaction, grade surface according to the proposed contours on the Drawings and place topsoil and grass seed.
- F. Buried Pipes: Buried pipes permanently removed from service shall be completely removed unless specifically noted otherwise.

- G. Care shall be taken to assure that demolition activity does not damage other facilities. Contractor shall make good, without additional cost to the Owner, work damaged by demolition activity.

3.02 SALVAGED MATERIALS

General: Remove carefully to avoid damages. Materials for reuse on this project (if any) are to be incorporated into new work if indicated.

Contractor shall verify that all items the Owner wishes to keep have been removed before beginning demolition.

Except for items indicated to be retained as Owner's property, other removed and salvaged materials not indicated for reuse shall become Contractor's property and removed from site with further disposition at Contractor's option.

3.03 DISPOSAL OF DEMOLISHED MATERIALS

- A. General: Remove weekly from site accumulated debris, rubbish, and other materials resulting from demolition operations.

- 1. No burning of any materials will be permitted on site.

- B. Removal: Transport materials removed from demolished structures and legally dispose of offsite.

END OF SECTION

Project Name: Born Court Well 1-7

Project Number: 2220555

FINISHES
DIVISION 9
TABLE OF CONTENTS

SECTION	TITLE
09 96 00	High Performance Coatings

PART 1 - GENERAL

1.01 SUMMARY

- A. This section includes surface preparation, painting, and finishing of exposed interior and exterior items and surfaces.
1. Surface preparation, priming, and finish coats specified in this section are in addition to shop priming and surface treatment specified under other sections.
 2. Coatings in this specification include shop and field applications. Contractor is responsible for complying with State of Michigan environmental coating compliance standards and volatile organic (VOC) regulations for shop and field applications of coatings. The State of Michigan has adopted Ozone Transport Commission Phase II Model Rule for Architectural and Industrial Maintenance (AIM) coatings.
- B. Paint all exposed surfaces except surfaces or items that are specifically indicated not to be painted or to remain natural. Where an item or surface is not specifically mentioned, paint the same as similar adjacent materials or surfaces. If color or finish is not designated, the Engineer will select from standard colors or finishes available.
- C. Painting is not required on pre-finished items, finished metal surfaces, concealed surfaces, operating parts, and labels unless otherwise noted.
1. Pre-finished items not to be painted include the following factory-finished components, but not limited to:
 - a. Acoustic materials.
 - b. Architectural woodwork and casework.
 - c. Finished mechanical and electrical equipment.
 - d. Light fixtures.
 - e. Distribution cabinets.
 2. Concealed surfaces not to be painted include wall or ceiling surfaces in the following generally inaccessible areas:
 - a. Foundation spaces.
 - b. Furred areas.
 - c. Utility tunnels.
 - d. Pipe spaces.
 - e. Duct shafts.
 3. Finished metal surfaces not to be painted include unless otherwise noted:
 - a. Anodized aluminum.
 - b. Stainless steel.
 - c. Chromium plate.
 - d. Copper.
 - e. Bronze.
 - f. Brass.
 4. Operating parts not to be painted include moving parts of operating equipment such as the following:
 - a. Valve and damper operators.
 - b. Linkages.
 - c. Sensing devices.
 - d. Motor and fan shafts.
 - e. Hardware
 5. Labels: Do not paint over Underwriter's Laboratories, Factory Mutual or other code-required labels or equipment name, identification, performance rating, or nomenclature plates.

1.02 REFERENCES

- A. Reference Organizations and Documents
1. American National Standards Institute (ANSI):
 - a. ANSI A13.1 Scheme for the Identification of Piping Systems
 - b. ANSI Z535.1 Safety Color Code
 - c. ANSI/ASC 29.4 Abrasive Blasting Operations – Ventilation and Safe Practice
 2. American Society for Testing Materials (ASTM)
 - a. ASTM D 16 Standard Terminology for Paint, Related Coatings, Materials, and Applications.
 - b. ASTM D 4285 Standard Test Method for Indicating Water or Oil in Compressed Air.
 - c. ASTM D 6386 Standard Practice for Preparation of Galvanized Iron & Steel
 - d. ASTM D 6944 Standard Test Method for Measuring Humidity with a Psychrometer.
 - e. ASTM F 1869 Standard Test Method for Measuring Moisture Vapor Emission Rate of Concrete Subfloor Using Anhydrous Calcium Chloride.
 3. American Water Works Association (AWWA)
 - a. AWWA D102-17 Coating Steel Water Storage Tanks
 - b. AWWA C210 Liquid-Epoxy Coating Systems for the Interior and Exterior of Steel Water Pipelines
 - c. AWWA C218 Coating the Exterior of Aboveground Steel Water Pipelines and Fittings
 4. International Concrete Repair Institute (ICRI)
 - a. 310.2R-2013 Selecting & Specifying Surface Preparation for Sealers, Coatings, Polymer Overlays, & Concrete Repair
 - b. 320.1R-1996 Guide for Selecting Application Methods for the Repair of Concrete Surfaces
 - c. 710.2-2014 Guide for Horizontal Waterproofing of Traffic Surfaces
 5. NACE International (NACE)
 - a. NACE 6D-173 A Manual for Painter Safety
 - b. NACE 6G-164 Surface Preparation Abrasives for Industrial Maintenance Painting
 - c. NACE TPC2 Coating and Lining for Immersion Service: Chapter 1 Safety, Surface Preparation, Chapter 3 Curing, and Chapter 2 Inspection
 - d. NACE 6F-163 Surface Preparation of Steel of Concrete Tank Interiors
 - e. NACE RP0892 Standard Recommended Practice, Lining over Concrete in Immersion Service.
 - f. NACE RP0288 Standard Recommended Practice, Inspection of Linings on Steel and Concrete.
 - g. NACE SP0188 Standard Practice for Discontinuity (Holiday) Testing of Protective Linings
 6. National Association of Pipe Fabricators (NAPF)
 - a. NAPF 500-03 Surface Preparation Standard for Ductile Iron Pipe and Fittings in Exposed Locations Receiving Special External Coatings and/or Special Internal Linings
 7. National Fire Protection Association (NFPA)
 - a. NFPA 101 Life Safety Code
 8. NSF International (NSF)
 - a. NSF/ANSI/CAN Standard 61 Drinking Water System Components
 - b. NSF/ANSI/CAN Standard 600

- 9. Ozone Transport Commission (OTC)
 - a. OTC Phase II Phase II Model Rule for Architectural and Industrial Maintenance (AIM) Coatings
- 10. The Society for Protective Coatings (SSPC)
 - a. SSPC-SP 1 Solvent Cleaning
 - b. SSPC-SP 2 Hand Tool Cleaning
 - c. SSPC-SP 3 Power Tool Cleaning
 - d. SSPC-SP 5 White Metal Blast Cleaning
 - e. SSPC-SP 6 Commercial Blast Cleaning
 - f. SSPC-SP 7 Brush-off Blast Cleaning
 - g. SSPC-SP 10 Near White Metal Blast Cleaning
 - h. SSPC-SP 11 Power Tool Cleaning to Bare Metal
 - i. SSPC-SP 13 Surface Preparation of Concrete
 - j. SSPC-SP 16 Brush-off Blast Cleaning of Non-Ferrous Metals
 - k. SSPC-SP WJ-4 Water Jet Cleaning of Metals
 - l. SSPC-PA 1 Painting Application Specification
 - m. SSPC-PA 2 Measurement of Dry Coating with Magnetic Gauges
 - n. SSPC-PA 3 A Guide for Safety in Paint Application
 - o. SSPC-Guide 12 Guide for Illumination of Industrial Painting Projects

1.03 DEFINITIONS

- A. "Paint" as used herein means all coating systems materials, primers, emulsions, enamels, stains, sealers and fillers, and other applied materials whether used as prime, intermediate, or finish coats.

1.04 SUBMITTALS

- A. Product Data: for each paint system specified, including block fillers and primers.
 - 1. Provide the manufacturer's technical information including label analysis and instructions for handling, storage, and application of each material proposed for use.
 - 2. List each material and cross-reference the specific coating, finish system, and application. Identify each material by the manufacturer's catalog number and general classification.
 - 3. Product data sheets shall indicate the mixing and thinning directions, and recommended spray nozzles and pressures.
- B. Samples for verification purposes: Provide samples of each color and material to be applied, with texture to simulate actual conditions, on representative samples of the actual substrate. Define each separate coat, including block fillers and primers. Use representative colors when preparing samples for review. Resubmit until required sheen, color, and texture are achieved.
- C. Provide safety data sheets (SDS).

1.05 QUALITY ASSURANCE

- A. Engage an experienced applicator that has experience in industrial or heavy commercial painting system applications and experience in painting wastewater or water treatment plants. The submission of five (5) successful paint projects of similar nature will be required if the Engineer is not familiar with the Subcontractor's work.
- B. Single-Source Responsibility: Provide primers and undercoat paint produced by the same manufacturer as the finish coats.
- C. Material Quality: Provide the manufacturer's paint material of the various coatings as specified. Paint material containers not displaying manufacturer's product identification will not be acceptable.

- D. Compatibility: Materials specified herein are compatible and complete systems. Any incompatible primers or barrier coats shall be removed and re-primed as directed by the Engineer. Notify the Engineer in writing of any anticipated problems using specified coating systems with substrates primed by others.
- E. Paint sample areas to establish standards on quality of workmanship as directed by the Engineer and to establish a basis for acceptability of the coating work. Project mock-ups and samples approved by the Engineer shall stay in place the remainder of the project to provide a standard of quality to which production work will be compared.

1.06 DELIVERY, STORAGE, AND HANDLING

- A. Deliver materials to the job site in the manufacturer's original, unopened packages and containers bearing manufacturer's name and label and the following information:
 - 1. Product name or title of material.
 - 2. Product description (generic classification or binder type).
 - 3. Manufacturer's lot number.
 - 4. Manufacturer's stock number and date of manufacture.
 - 5. Contents by volume, for pigment and vehicle constituents.
 - 6. Thinning instructions.
 - 7. Application instructions.
 - 8. Color name and number.
 - 9. Expiration date (after which the product should not be used).
- B. Containers that have been broken, opened, water marked and contain caked, lumpy or otherwise damaged materials are unacceptable and shall be removed from the work site immediately.
- C. Store materials not in use in tightly covered containers in a well-ventilated area at a minimum ambient temperature of 45 deg F (7 deg C). Maintain containers used in storage in a clean condition, free of foreign materials and residue. The Contractor shall exercise every precaution in the storage of paints, solvents, cleaning fluids, rags and similar materials to eliminate the risk of spontaneous combustion or other hazardous conditions. Portable fire extinguishing equipment shall be provided in a convenient location for emergency access. All painting materials stored on the job site shall be stored in a location consistent to the manufacturer's storage requirements. The Contractor shall take all safety precautions in accordance with Section 7 of AWWA d-102 and NFPA Bulletin No. 101.

1.07 PROJECT/SITE CONDITIONS

- A. Apply paints only when the temperature of surfaces to be painted and surrounding air temperatures are between 50 deg F (10 deg C) and 90 deg F (32 deg C). These temperatures need to be maintained throughout the minimum cure time as recommended by the manufacturer.
- B. The coatings shall be supplied for normal use without thinning. If it is necessary to thin the coating for proper application in cool weather or obtain better coverage for a protected coating of urethane application, the thinning shall be done in accordance with manufacturer's recommendations.
- C. Do not apply paint to wet or damp surfaces, or during snow, rain, fog, or mist. No paint shall be applied when it is expected that the relative humidity will exceed 85 percent or that the air temperature will drop below manufacturer's requirements within 18 hours after the application of the paint. Dew or moisture condensation should be anticipated and if such conditions are prevalent, painting shall be delayed until the Engineer is satisfied that the surface is dry.

- D. Air quality permits, requirements, and other construction related permits shall be the responsibility of the Contractor. Copies of the permits shall be attached to the Field Superintendents copy of the specifications and shall be on the job site at all times.
- E. Adjacent Work – Protect work of other trades covered in these specifications and in other sections and in other sections against damage by painting and finishing work. Correct any damage by repairing, cleaning, replacing, or repainting any of the damaged areas as acceptable to the Engineer.
- F. Provide “Wet Paint” signs as required to protect freshly painted surfaces from the damage.

PART 2 - PRODUCTS

2.01 MANUFACTURERS

- A. Manufacturer: All materials specified herein shall be base bid as manufactured by the Tnemec Company, Inc., Kansas City, MO. These products are specified to establish standards of quality and are approved for use on this project. The listing or description of these products shall not be construed so as to eliminate from competition other products of equal performance, which are similar in design, function, and performance. The products were selected by application, performance requirements, and ASTM Testing. Proposed alternates shall meet or exceed criteria (application, performance, and ASTM testing) for each product. Materials by other manufacturers shall be approved per Section 01 60 00 – “Materials and Equipment.”

2.02 PAINT MATERIALS

- A. Material Compatibility: Provide block fillers, finish coat materials, and related materials that are compatible with one another and the substrates indicated under conditions of service and application, as demonstrated by the manufacturer based on testing and field experience.
- B. Colors: Provide color selections made by the Owner from the manufacturer's full range of standard colors.

PART 3 - EXECUTION

3.01 EXAMINATION

- A. The Contractor shall examine Work-in-Place that work included in this section is dependent. Any defects that may influence the satisfactory performance of any work of this section shall be corrected in accordance with the requirements governed by the section under which the defects are noted. The Contractor shall be solely responsible for assuring that Work-in-Place is acceptable to satisfy the requirements of this section. Commencement of work under this section shall be construed as Work-in-Place being acceptable to the Contractor.
- B. Coordination of Work: Review other sections in which primers are provided to ensure compatibility of the total system for various substrates on request. Furnish information on characteristics of finish materials to ensure use of compatible primers.
 - 1. Notify the Engineer about anticipated problems using the materials specified over substrates primed by others.

3.02 PREPARATION:

- A. General Procedures: Remove hardware and hardware accessories, plates, machined surfaces, lighting fixtures, and similar items in place that are not to be painted, or provide surface-applied

protection prior to surface preparation and painting. Remove these items if necessary for complete painting of the items and adjacent surfaces. Following completion of painting operations in each space or area, have items reinstalled by workers skilled in the trades involved.

1. Clean surfaces before applying paint or surface treatments. Remove oil and grease prior to cleaning. Schedule cleaning and painting so that dust and other contaminants from the cleaning process will not fall on wet, newly painted surfaces.
- B. Surface Preparation: Clean and prepare surfaces to be painted in accordance with the manufacturer's instructions and SSPC for each particular substrate condition and as specified.
1. Provide barrier coats over incompatible primers or remove and re-prime. Notify the Engineer in writing of problems anticipated with using the specified finish-coat material with substrates primed by others.
 2. Cementitious Materials: Prepare concrete, concrete masonry block, cement plaster, and mineral-fiber-reinforced cement panel surfaces to be painted. Remove efflorescence, chalk, dust, dirt, grease, oils, laitance, and release agents. Roughen as required to remove glaze. If hardeners or sealers have been used to improve curing, use mechanical methods of surface preparation.
 - a. Use abrasive blast-cleaning methods if recommended by the paint manufacturer.
 - b. Determine alkalinity and moisture content of surfaces by performing appropriate tests. If surfaces are sufficiently alkaline to cause blistering and burning of finish paint, correct this condition before application. Do not paint surfaces where moisture content exceeds that permitted in manufacturer's printed directions.
 - c. Thin first coat of coal tar to allow penetration into concrete, per manufacturer's recommendations.
 3. Concrete – Below Grade Non-Immersion: All concrete shall be allowed to cure twenty-eight (28) days before applying any coatings. Prepare referencing SSPC-SP 13 Surface Preparation of Concrete. All surfaces must be clean, dry and free of contaminants.
 4. Concrete – Above Grade Exterior Exposed and Interior Non-immersed: Allow concrete to cure twenty-eight (28) days before applying any coatings. Prepare referencing SSPC-SP 13 Surface Preparation of Concrete. All surfaces must be clean, dry and free of contaminants.
 5. Concrete Masonry Units: Allow mortar to cure for twenty-eight (28) days. Level protrusions and mortar splatter. Prepare referencing SSPC-SP 13 Surface Preparation of Concrete. All surfaces shall be clean, free of efflorescence, chalk, dust, grease, oils and dry.
 6. Concrete Floor: Concrete floors shall be allowed to cure twenty-eight (28) days. Mechanically abrade by means of abrasive shot blast or diamond grinding equipment referencing SSPC-SP 13 Surface Preparation of Concrete to uniformly produce the required surface ICRI CSP surface profile. Acceptable equipment to produce the required surface profile shall be as prescribed per ICRI Technical Guideline No. 310.2R, Table 7.2, with the noted exception that acid etching and surface retarders shall not be permitted. Floors shall be free of laitance, clean and dry before applying coatings.
 7. Previously Coated Concrete – Exterior: Power washing at 2500 psi with detergent or brush off blast referencing SSPC-SP 13 Surface Preparation of Concrete required. Concrete shall be clean and dry before applying coatings.
 8. Previously Coated Concrete & Concrete Masonry – Interior: Power washing at 2500 psi with detergent required except where electrical components could be damaged. Hand tools shall be used around electrical panels and equipment. Protect all panels and equipment. Concrete shall be clean and dry before applying coatings.
 9. Plaster and Wallboard: All surfaces shall be clean, dry and free of contaminants. Sand joint compound and feather edges.
 10. Ferrous Metals: Clean non-galvanized ferrous-metal surfaces that have not been shop coated; remove oil, grease, dirt, loose mill scale, and other foreign substances.

- a. All the surfaces to be coated shall be blast cleaned in accordance with the surface preparation standard listed in the schedule.
 - b. The abrasive used for blast cleaning shall be an approved low dusting abrasive and shall have a gradation such that the abrasive will produce a uniform profile of 1 to 2.5 mils, as measured with extra coarse Testex Replica Tape.
 - c. All abrasive and coating residue shall be removed from steel surfaces with a commercial grade vacuum cleaner equipped with a brush-type cleaning tool, or by double blowing. If the double blowing method is used, the exposed top surfaces of all structural steel, including flanges, longitudinal stiffeners splice plates, hangers, etc., shall be vacuumed after the double blowing operations are completed. The airline used for blowing the steel clean shall have an in-line water trap and the air shall be free of oil and water as it leaves the air line. The steel shall then be kept dust free and primed within eight (8) hours after blast cleaning.
 - d. Touch up bare areas and shop-applied prime coats that have been damaged. Wire-brush, clean with solvents recommended by the paint manufacturer, and touch up with the same primer as the shop coat.
11. Non-Ferrous: Clean non-ferrous surfaces with non-petroleum-based solvents so that the surface is free of oil and surface contaminants as defined in SSPC-SP1, followed by abrasive blasting referencing SSPC-SP 16
 12. Ductile Iron: NAFP 500-03-04 Abrasive Blast Cleaning of Ductile Iron Pipe
 13. PVC Pipe: Sand using 36 grit paper all PVC piping that is to receive coatings to roughen up the surface and create a profile. All sanded surfaces shall be clean and dry before applying coatings.
 14. Copper Pipe: Abrade surface to generate a profile for mechanical adhesion.
 15. Wood: Clean surfaces of dirt, oil, and other foreign substances with scrapers, mineral spirits, and sandpaper, as required. Sand surfaces exposed to view smooth and dust off.
 - a. Scrape and clean small, dry, seasoned knots and apply a thin coat of white shellac or other recommended knot sealer before application of primer. After priming, fill holes and imperfections in finish surfaces with putty or plastic wood filler. Sand smooth when dried.
 - b. Prime, stain, or seal wood to be painted immediately upon delivery. Prime edges, ends, faces, undersides, and backsides of wood, including cabinets, counters, cases, and paneling.
 - c. When transparent finish is required, back-prime with spar varnish.
 - d. Back-prime paneling on interior partitions where masonry, plaster, or other wet wall construction occurs on backside.
 - e. Seal tops, bottoms, and cutouts of unprimed wood doors with a heavy coat of varnish or sealer immediately upon delivery.
- C. Materials Preparation: Carefully mix and prepare paint materials in accordance with manufacturer's directions.
1. Maintain containers used in mixing and application of paint in a clean condition, free of foreign materials and residue.
 2. Stir material before application to produce a mixture of uniform density; stir as required during application. Do not stir surface film into material. Remove film and, if necessary, strain material before using.
 3. Use only thinners approved by the paint manufacturer, and only within recommended limits.
 4. Epoxy, Coal Tar Epoxy and Urethane Coatings:
 - a. The coating shall be mixed with a high shear mixer (such as Jiffy Mixer) in accordance with the manufacturer's directions, to a smooth, lump-free consistency. Paddle mixers or paint shakers are not permitted. Mixing shall be done, as far as possible, in the original containers and shall be continued until all of the metallic powder or pigment is in suspension. Care shall be taken to ensure

that all of the coating solids that may have settled to the bottom of the container are thoroughly dispersed. The coating shall then be strained through a screen having openings no larger than those specified for a No. 50 sieve in ASTM E11. After straining, the mixed primer shall be kept under continuous agitation up to and during the time of application.

3.03 APPLICATION

- A. Apply paint in accordance with manufacturer's directions and good painting practices under SSPC. Use applicators and techniques best suited for substrate and type of material being applied.
- B. Do not paint over dirt, rust, scale, grease, moisture, scuffed surfaces, fraying surfaces or conditions detrimental to formation of a durable paint film.
1. Paint colors, surface treatments, and finishes are indicated in "schedules."
 2. Provide finish coats that are compatible with primers used.
 3. The number of coats and film thickness required is the same regardless of the application method. Do not apply succeeding coats until the previous coat has cured as recommended by the manufacturer. Sand between applications where sanding is required to produce an even smooth surface in accordance with the manufacturer's directions.
 4. Apply additional coats when undercoats, stains, or other conditions show through final coat of paint until paint film is of uniform finish, color, and appearance. Give special attention to ensure that surfaces, including edges, corners, crevices, welds, and exposed fasteners, receive a dry film thickness equivalent to that of flat surfaces.
 5. The term "exposed surfaces" includes areas visible when permanent or built-in fixtures, convector covers, covers for finned tube radiation, grilles, and similar components are in place. Extend coatings in these areas as required to maintain the system integrity and provide desired protection.
 6. Paint surfaces behind movable equipment and furniture same as similar exposed surfaces. Paint surfaces behind permanently fixed equipment or furniture with prime coat only before final installation of equipment.
 7. Paint interior surfaces of ducts, where visible through registers or grilles, with a flat, non-specular black paint.
 8. Paint back-sides of access panels and removable or hinged covers to match exposed surfaces.
 9. Finish interior of wall and base cabinets and similar field-finished casework to match exterior.
 10. Finish doors on tops, bottoms, and side edges same as exterior faces.
 11. Sand lightly between each succeeding enamel or varnish coat.
 12. Omit primer on metal surfaces that have been shop-primed and touch up painted.
- C. Proper curing conditions for ferrous metals will be required between the applications of all coats. The minimum curing time between coats and the maximum time between coats shall be in accordance with the manufacturer's recommendation except that no more than sixty, (60), calendar days will be permitted between coats. If the maximum time between coats is exceeded, all newly coated surfaces shall be completely blast cleaned again to a near-white finish (SSPC-SP10) and recoated and shall be at the Contractor's expense. Whatever metal is cleaned during a working day shall be coated with the prime coat the same day. After the steel is primed, it shall be vacuumed again before subsequent coating. If for any reason this vacuuming does not remove all the accumulated dust and/or dirt, or if more than three (3) weeks has elapsed since the steel was primed, or if in the opinion of the Engineer the surface is unfit for top-coating, the surface shall be scrubbed with a mild detergent solution (any commercial laundry detergent) and thoroughly rinsed with water and allowed to dry for twenty-four (24) hours before the surface is coated.
- D. Minimum Coating Thickness: Apply materials at not less than the manufacturer's recommended spreading rate. Provide a total dry film thickness of the entire system as recommended by the

manufacturer and as stated in paint schedules. If the application of coating at the required thickness in one (1) pass produces runs, bubbles, or sags, the coating shall be applied in multiple passes, the passes separated by several minutes. Where excessive coating thickness produces "mud-cracking", such coating shall be scraped back to soundly bonded coating and the area recoated to the required thickness. All dry spray shall be removed, by sanding if necessary. In areas of deficient primer thickness, the areas shall be thoroughly cleaned with power washing equipment, as necessary to remove all dirt; the areas shall then be wire brushed, vacuumed, and recoated. Each undercoat shall be tinted a lighter shade to facilitate identification of each coat where multiple coats are applied. The Engineer will require certification from the approved coating manufacturer that sufficient materials of each coating specified were purchased to complete the scope of work indicated in these specifications and on the drawings.

- E. Mechanical and Electrical Work: Painting mechanical and electrical work is limited to items exposed in mechanical equipment rooms and in occupied spaces.
- F. Block Fillers: Apply block fillers to concrete masonry block at a rate to ensure complete coverage with pores filled.
- G. Stipple Enamel Finish: Roll and redistribute paint to an even and fine texture. Leave no evidence of rolling such as laps, irregularity in texture, skid marks, or other surface imperfections.
- H. Pigmented (Opaque) Finishes: Completely cover to provide an opaque, smooth surface of uniform finish, color, appearance, and coverage. Cloudiness, spotting, holidays, laps, brush marks, runs, sags, ropiness, or other surface imperfections will not be acceptable.
- I. Transparent (Clear-White) Finishes: Use multiple coats to produce a glass-smooth surface film of even luster. Provide a finish free of laps, cloudiness, color irregularity, runs, brush marks, orange peel, nail holes, or other surface imperfections.
- J. Completed Work: Match approved samples for color, texture, and coverage. Remove, refinish, or repaint work not in compliance with specified requirements.
- K. All metal coated with impure unsatisfactory or unauthorized coating material or coated in an unworkmanlike or objectionable manner shall be thoroughly cleaned and recoated or otherwise corrected as directed by the Engineer.

3.04 FIELD QUALITY AND CONTROL

- A. The Contractor shall provide access to the job site and areas of work at all times during normal working hours for the Owner. This requirement includes both shop and work in the field.
- B. The Engineer or an outside inspection service representing the Owner may make inspections of the work in progress and completed work. Contractor shall coordinate with Engineer or outside inspection agency to allow for inspections after surface preparation and after each coating is applied.

Should the Engineer be summoned to inspect a completed phase of the work and find the work incomplete and therefore, not ready for inspection, the Contractor shall bear the cost of the

inspection. It is not the intent to charge the Contractor for an inspection if discrepancies are found in the completed phase of the construction as long as the discrepancies do not necessitate additional inspection trips. Field inspections may be performed by the Engineer according to the following outline:

1. Surface Preparation:
 - a. Surface appearance per SSPC checked with visual standards.
 - b. Anchor profile checked with replica tape.
 2. Coating Conditions:
 - a. Temperature of steel using a surface thermometer.
 - b. Determination of relative humidity and dew point and air temperature using a sling psychrometer.
 3. Verification of Coating Thickness:
 - a. Dry film thickness will be determined by use of a magnetic film thickness gauge.
 - b. Pin holes will be checked using a holiday detector.
 4. The Contractor shall supply the following test equipment and standards. This equipment shall be on the job site and available to the on-site inspector at all times:
 - a. Wet Film Thickness Gauges
 - b. SSPC Vis-1 pictorial standards
 - c. Magnetic Dry Film Thickness Gauge 0 to 45 mils
 - d. Dry Film Thickness Calibration Standards
 - e. Tooke Gauge
 - f. Holiday detection device
 - g. Surface Temperature Gauges
 - h. Sling Psychrometer or equal
- C. Failure to comply with these specifications in any manner shall be sufficient cause for rejection of work.

3.05 CLEAN-UP AND PROTECTION

- A. Cleanup: At the end of each work day, remove empty cans, rags, rubbish, and other discarded paint materials from the site.
- B. Upon completion of painting, clean glass and paint-spattered surfaces. Remove spattered paint by washing and scraping, using care not to scratch or damage adjacent finished surfaces.
- C. Protect work of other trades, whether to be painted or not, against damage by painting. Correct the damage by cleaning, repairing or replacing, and repainting, as acceptable to the Engineer.
- D. Provide "wet paint" signs to protect newly painted finishes. Remove temporary protective wrappings provided by others for protection of their work after completion of painting operations.
 1. At completion of construction activities of other trades, touch up and restore damaged or defaced painted surfaces.

3.06 PAINT SCHEDULE

- A. General: Paint all surfaces as noted in this Paint Schedule and the Finish Schedules included in the Drawings. Also paint items and surfaces where noted on the Drawings and in the Sections of the Specifications. NOTIFY ENGINEER when ready to select colors and, again, when ready to commence the work, and prior to applying the final coat. Where only two coats are noted, the result must give total coverage or an added coat shall be applied.
 1. All non-wearing surfaces, supports, frames, etc., except galvanized parts, shall be painted in accord with the painting schedule.

2. Paint hollow metal doors and frames and overhead doors.
3. Paint the following items if exposed to view and not factory finished:
 - a. Wood.
 - b. Masonry walls.
 - c. Metal, except stainless steel, copper, brass, and aluminum unless noted.
 - d. Mechanical ductwork, piping (including copper and brass), and associated supports, cabinets, covers, grilles, register, diffusers and appurtenances.
 - e. Electrical conduit, boxes, panels, and appurtenances.
4. When exposed to the exterior elements and not factory finished, paint the following items:
 - a. Wood
 - b. Metal, except stainless steel, copper, brass or aluminum unless noted.
 - c. Concrete
 - d. Block masonry
 - e. Mechanical stacks, vents, pipes, drain cocks, equipment and appurtenances.
 - f. Electrical panels, equipment and appurtenances.
5. Factory finishes shall be touched up with a matching material if scratched, stained or otherwise damaged. When noted, factory finished items shall be field painted. Prime coat, galvanizing or similar treatment do not constitute a factory finish exempted from field painting. The overhead door shall be painted at the job site.
6. Do not paint over code required labels such as UL or FM, or any equipment identification, performance rating, name or nomenclature plates.
7. Do not paint moving parts of operating mechanical and electrical equipment such as valve and damper operators, linkages, sensing devices, or motor and fan shafts.
8. The following painting schedule is based on the products of the Tnemec Company, Inc. Schedule contains minimum number of coats required to achieve specified dry film thickness.
9. See Section 40 05 13 – “Process Piping” for coating of inside of pipes. Interior and exterior noted in schedule below refers to building environment.

C. DUCTILE IRON PIPE

Exterior Ductile Iron Pipe and Fittings Including all Hardware

Surface Prep:	NAPF 500-03-04/NAPF 500-03-05	
Shop Prime:	Tnemec Series 37H, N69, or V69	2.0 to 3.5 mils DFT
or Field Prime:	Tnemec Series V69	2.0 to 3.5 mils DFT
Intermediate:	Tnemec Series V69	4.0 to 6.0 mils DFT
Finish:	Tnemec Series 1094	2.0 to 3.0 mils DFT

D. EQUIPMENT

Exterior Factory Primed Equipment and Motors –

Shop Prime:	Tnemec Series 37H, N69, or V69	2.0 to 3.0 mils DFT
Surface Prep:	Surface shall be dry and clean	
Prime:	Tnemec Series V69	4.0 to 6.0 mils DFT
Finish:	Tnemec Series 1094	2.0 to 3.0 mils DFT

3.07 WATER TREATMENT/SUPPLY FINISH COLOR SCHEME

- A. Color Selection: Paint colors will be selected by Engineer. Before painting the Contractor shall submit Paint Specifications and color chips for review by Engineer.
 1. Furnish colors exactly matching the selected colors.
 2. Obtain approval from Engineer of proposed color matches.

3. Paint wood, metal, and mechanical and electrical appurtenances the same color as adjacent building surface unless noted.
4. Refer to architectural drawings for special painting considerations for accent color walls.
5. The “Ten State Standards” recommended piping color scheme shall be utilized for piping and is as follows:

Piping	Color Description	Tnemec Color
Raw Water	Olive Green	Gale Force 97GN
Filtered Water	Light Blue	Fountainbleau 25BL
Potable/Finished	Dark Blue	Safety Blue 11SF
Drain Lines, Vent Lines	Gray	Slate Gray 31GR
Other Lines	Gray	Slate Gray 31 GR

6. Verify pipe color scheme with Engineer prior to application to confirm whether a different shade from the above listed piping color scheme is required.
7. Flexible electrical conduit shall remain unpainted.

3.09 LABELS

- A. Piping shall be identified by labels and flow arrows every ten feet with at least two labels in each room.
- B. The contents and direction of flow shall be stenciled on the piping with paint in a contrasting color. Coordinate label text with Owner and Engineer.
- C. Minimum text size for 16" and larger pipe shall be 4".
- D. Minimum text size for pipe smaller than 16" shall be 2".
- E. Labels for PVC and copper pipe shall not be painted, see Section 40 05 13 – “Process Piping.”
- F. Pipe contents and flow direction labels shall NOT be included in the allowance for signage.

3.10 SURFACE PREPARATION - SSPC DESCRIPTIONS

- A. Reference is made to Steel Structures Painting Council (SSPC) surface preparation specifications for recommended surface cleaning.

3.11 SURFACE PREPARATION - NAPF DESCRIPTIONS

- A. Reference is made to National Association of Pipe Fitters (NAPF) surface preparation specifications for recommended surface cleaning of ductile iron pipe and fittings.

NAPF 500-03-04 Abrasive Blast Cleaning for Ductile Iron Pipe:

Removal of all visible dirt, dust, loose annealing oxide, loose rust, loose mold coating and other foreign matter. All oils, small deposits of asphalt paint and grease shall have been removed prior to blasting by solvent cleaning per NAPF 500-03-01. After the entire surface to be coated is struck by the blast media, tightly adherent annealing oxide, mold coating and rust staining may remain on the surface provided they cannot be removed by lifting with a dull putty knife. No asphaltic coating shall be allowed to remain.

NAPF 500-03-05 Abrasive Blast Cleaning for Ductile Iron Fittings:

Removal of all visible dirt, dust, loose annealing oxide, loose rust, loose mold coating and other foreign matter. All oils, small deposits of asphalt paint and grease shall have been removed prior to blasting by solvent cleaning per NAPF 500-03-01. After the entire surface to be coated is struck by the blast media, tightly adherent annealing oxide, mold

Project Name: Born Court Well 1-7
Project Number: 2220555

SECTION 09 96 00
HIGH PERFORMANCE COATINGS

coating and rust staining may remain on the surface provided they cannot be removed by lifting with a dull putty knife. For fittings previously coated with asphaltic paint, no staining may remain on the surface after abrasive blast cleaning.END OF SECTION

ELECTRICAL SPECIFICATIONS
DIVISION 26
TABLE OF CONTENTS

SECTION	TITLE
26 05 00	Electrical General Provisions
26 05 19	Electrical Conductors
26 05 26	Grounding
26 05 33	Conduit
26 05 34	Electrical Boxes
26 05 44	Manholes & Handholes
26 05 53	Electrical Identification
26 24 18	Mini Power Centers
26 28 13	Fuses
26 28 16	Motor & Circuit Disconnects
26 28 17	Circuit Breakers
26 29 13	Motor Controllers
26 43 13	Surge Protection Devices

PART 1 - GENERAL

1.01 RELATED DOCUMENTS

- A. Drawings and general provisions of the contract, including General and Supplementary Conditions and Division 01 Specification sections, apply to this section. If differing requirements are identified elsewhere (in these specifications or on drawings or separate instructions), the more stringent requirement shall be met.

1.02 SECTION INCLUDES

- A. General provisions for electrical work for improvements to the City of Kalamazoo Born Court Well located in Kalamazoo County, Michigan.
- B. Coordinate construction activities, relocation, and installation for electrical related systems with other trades.

1.03 SUMMARY OF WORK

- A. General:
 - 1. Prior to performing the work, the Contractor shall familiarize himself with the site, and be aware of limitations to consider when accessing the work location with construction equipment. Coordinate all work on site with the Engineer, particularly related to sequence, placement, storage, lifting, etc., of all construction equipment and materials.
 - 2. Obtain permits required by the city and other local jurisdictions for work performed.
 - 3. Coordinate demolition, layout and installation of all work with other Contractors onsite and through the Engineer.
 - 4. Furnish and install all support devices including miscellaneous steel, hangers, brackets, clamps, anchors, etc., as required to adequately install, support, and maintain all conduit, cable tray, cables, lighting, distribution equipment, instruments, devices, and fixtures installed.
 - 5. Layout, coordinate, furnish and install all sleeves, flashing, and patching as required for all wall, roof, floor, grating, etc., penetrations for all work. Utilize a roofing contractor for cutting and patching at all roof penetrations for piping and supports.
 - 6. Field touch-up paint to existing condition, all equipment damaged or installed by work in accordance with Owner's painting standards and the technical specifications.
 - 7. Coordinate deliveries, receipt, handling, offloading, storage and security for all Contractor furnished materials. The Owner or Engineer will not be responsible for lost or stolen materials furnished by Contractor and will not assume responsibility for materials until satisfactory installation. Coordinate onsite storage of all Contractor furnished materials and equipment with the Engineer.
 - 8. Receive, inspect, offload, store, stage, and protect all equipment, devices, and materials furnished by the Owner.
 - 9. Furnish and install all equipment grounding.
 - 10. "Commission" or energize all equipment and systems installed by this contract including coordination with Engineer and other contractors.
 - 11. Provide start-up assistance for systems furnished.
 - 12. Maintain on site a detailed as-built record set of all work installed as applicable. Final set to be submitted to Engineer upon completion of work.
- B. General Demolition Requirements:
 - 1. Refer to the drawings for specific demolition of electrical feeders and other major items as noted on the single line diagrams and plan drawings. Remove associated conduit, supports and wiring along with the equipment.
 - 2. All equipment required by EGLE permit for operation of the treatment process shall be maintained in operation.
 - 3. Patch with grout all walls and surfaces that are penetrated by electrical equipment that is removed. Paint all patch material to match existing surface coating.

4. Paint walls behind removed electrical components where wall has been exposed to match existing surface coating. Paint walls before installing new components mounted in the same place where existing equipment was removed.
 5. All abandoned conduits exposed in buildings not scheduled to remain shall be removed and properly disposed of per Division 1 requirements.
- C. General Proposed Requirements:
1. Refer to the drawings for specific proposed electrical improvements and other major items as noted on the specifications and drawings. Provide all associated conduit, supports, and wiring along with the proposed equipment.
 2. Programming of SCADA equipment will be performed by City of Kalamazoo.

1.04 STANDARDS

- A. Applicable Standards and Codes:
1. Institute of Electrical and Electronic Engineers (IEEE).
 2. Underwriters Laboratories, Inc. (UL).
 3. National Electrical Manufacturers Association (NEMA).
 4. National Electrical Code (NEC).
 5. American Society for Testing and Materials (ASTM).
 6. American National Standards Institute (ANSI).
 7. National Board of Fire Underwriters (NBFU).
 8. National Fire Protection Association (NFPA).
 9. National Electrical Contractors "Standard of Installation" (NECA)
 10. Joint Industrial Council (JIC).
 11. Code of Federal Regulations (CFR). Title 29 Labor, Subpart S-Electrical.
- B. Where quantities, sizes, or other requirements shown on the drawings or specified herein exceed the requirements of the above standards and codes, the drawings and specifications shall govern.

1.05 SUBMITTALS

- A. Submit under provision of the project specifications.
- B. Submit materials and equipment for review to Engineer as required in each section. Each sheet of descriptive literature submitted shall be clearly marked to identify the material or equipment and shall show the specification paragraph for which the equipment applies.
1. Submit schematics and connection diagrams for all electrical equipment. A manufacturer's standard connection diagram or schematic showing more than one scheme of connection will not be accepted unless it is clearly marked to show the intended connections.
 2. Submittals showing more than the particular item under consideration shall have the pertinent description paragraph for which the equipment applies circled or highlighted with a marker intended for that purpose.
- C. Prepare and maintain record drawings current with work completed. Show all changes to underground and other hidden work. Submit to Engineer on completion of project.
- D. After award of the contract and prior to starting any work the Contractor shall submit to the Engineer:
1. List of subcontractors scheduled and planned for utilization on the project.
 2. Detailed work plans outlining methods and procedures to accomplish the intent and purpose of the contract.
 3. Work schedule detailing dates of principle events and completion date. All downtime needed in the schedule shall be approved by the Owner.

- E. Operating and Maintenance Instructions:
 - 1. Upon completion of all work and tests, instruct the Owner in the operation and maintenance of all components.
 - 2. Furnish sets of written Operation and Maintenance Manuals per Division 1 - Submittals.

1.06 CLEARANCES

- A. Equipment:
 - 1. Maintain clearances from electric panels, and other electrical installations as required by NEC and CFR.
 - 2. Maintain working clearances around electrical equipment as required for proper maintenance and operation.

1.07 IDENTIFICATIONS

- A. Provide identification signs on all electrical equipment, control panels, switches, breakers, and panels.
- B. Provide a type written circuit identification schedule in each distribution or branch circuit panelboard under glass or plastic. Each circuit to be identified by load.

1.08 CODES AND STANDARDS

- A. These specifications are minimum requirements and shall govern except where made more stringent by other sections of this specification or local, state, or federal laws or regulations. In the event of conflict between these specifications and applicable codes and regulations, the codes and regulations shall govern.

1.09 PERMITS AND INSPECTIONS

- A. Obtain all necessary permits and pay all fees in connection with all permits, inspections, and approval by the proper authorities in local jurisdiction of such work. Final inspection by the Owner will not occur until necessary certificates of satisfactory inspection are received.

1.10 DRAWINGS

- A. Drawings and specifications are provided for assistance to the Contractor and are diagrammatic only to indicate the general arrangement and location of circuits, outlets, etc. Exact locations will be determined by field conditions. Deviations from the arrangement indicated to meet actual conditions shall be made with no expense to the Owner. Throughout the progress of construction, the Contractor shall keep a set of detailed field record drawings, including the exact location of concealed work and underground utilities. This requirement does not authorize any deviations from the contract drawings without prior approval from the Owner. The field record information shall be marked in a legible manner on prints of the drawings. At the completion of work, the Contractor shall deliver the field record information to the Owner.

PART 2 - PRODUCTS

2.01 MATERIALS

- A. All electrical equipment and material shall be furnished new and shall be accepted, or certified, or listed or labeled or otherwise determined to be safe by a Nationally Recognized Testing Laboratory (NRTL).
 - 1. Equipment shall be accepted, certified listed labeled by UL and Factory Mutual Insurance Company (FM).
 - 2. Equipment or material accepted certified, listed or labeled by an accepted NRTL shall be used in preference to equipment or material that does not have that acceptance.

SECTION 26 05 00
ELECTRICAL GENERAL PROVISIONS

3. If equipment or material has been inspected or tested by a federal agency or by the State of Michigan or by the municipality having jurisdictional responsibility for enforcing occupational safety provisions of the NEC and found in compliance with the provisions of the NEC as applied in paragraph 1910.309 of Department of Labor General Industry Safety Standards Commission Bulletin.
 4. Custom manufactured or installed equipment shall use components accepted, certified, listed or labeled by a NRTL and manufactured shall submit data indicating such acceptance, certification listing or labeling to the Engineer.
- B. Substitutions for materials and equipment listed herein must be of equal standards, quality, and desired operation, or superior. There will be no approval or consideration for approval of equipment or material submittals for substitution prior to award of the contract.
- C. All packaged equipment shall be completely factory-wired prior to delivery to the jobsite. Connection to and bonding of this equipment is required under this section of the specifications.
1. Check all pre-wired controls before energizing to verify that all internal wiring is properly coordinated to the voltage to be applied.

2.02 SHOP/FACTORY/FINISHING

- A. Provide baked enamel finishes on exposed surfaces.
- B. Provide galvanized finishes for damp or wet locations.
- C. Touch up or refinish damaged paint.

PART 3 - EXECUTION

3.01 INSTALLATION

- A. Provide and install all equipment as specified, required or implied in this specification except as noted. This requirement shall include all labor, materials, and incidentals in a manner consistent with good practice necessary to a complete operable installation.
- B. The Contractor shall implement cooperation with other trades by his reference to the structural and mechanical drawings and specifications for work by other trades and to be carried on simultaneously or sequentially with the electrical work. This requirement is to facilitate construction to proceed with no harm to the Owner due to the absence of cooperation. All other drawings and specifications shall become part of the electrical specifications as they relate to electrical work.
- C. Verify equipment dimensions to insure dimensional compatibility.
- D. All excavation, backfilling, and concrete work shall conform to the applicable sections of these specifications.
- E. The Contractor is responsible for connecting wiring and circuitry to all equipment furnished by others and the Contractor that requires electrical power or control.

3.02 HANGERS AND SUPPORTS

- A. Corrosive Environments: Utilize non-metallic PVC fitting compatible with Schedule 80 PVC conduit and fittings. Provide stainless steel fasteners.
- B. Wet Environments: Utilize hot dipped galvanized PVC coated or stainless-steel supports and fasteners as appropriate for environment.

- C. Anchors and Fasteners:
 - 1. Concrete Structural Elements: Provide precast inserts, expansion anchors, powder actuated anchors and preset inserts.
 - 2. Steel Structural Elements: Provide beam clamps and steel ramset fasteners.
 - 3. Concrete Surfaces: Provide self-drilling anchors and expansion anchors.
 - 4. Hollow Masonry, Plaster, and Gypsum Board Partitions: Provide toggle bolts and hollow wall fasteners.
 - 5. Solid Masonry Walls: Provide expansion anchors and preset inserts.
 - 6. Sheet Metal: Provide sheet metal screws.
 - 7. Wood Elements: Provide wood screws.

- D. Inserts:
 - 1. Install inserts for placement in concrete forms.
 - 2. Install inserts for suspending hangers from reinforced concrete slabs and sides of reinforced concrete beams.
 - 3. Provide hooked rod to concrete reinforcement section for inserts carrying pipe over 4 inches.
 - 4. Where concrete slabs form finished ceiling, locate inserts flush with slab surface.
 - 5. Where inserts are omitted, drill through concrete slab from below and provide through-bolt with recessed square steel plate and nut flush with top of slab.

- E. Install conduit and raceway support and spacing in accordance with NEC.

- F. Do not fasten supports to pipes, ducts, mechanical equipment, or conduit.

- G. Install multiple conduit runs on common hangers.

- H. Supports:
 - 1. Fabricate supports from structural steel or formed steel channel. Install hexagon head bolts to present neat appearance with adequate strength and rigidity. Install spring lock washers under nuts.
 - 2. Install surface mounted cabinets and panelboards with minimum of four anchors.
 - 3. In wet and damp locations install steel channel supports to space cabinets and panelboards 1 inch off wall.
 - 4. Support vertical conduit at every floor and coupling, minimum.

3.03 EQUIPMENT BASES AND SUPPORTS

- A. Provide housekeeping pads of concrete, nominal 4 inches thick and extending 6 inches beyond supported equipment, for all free-standing equipment.

- B. Using templates furnished with equipment, install anchor bolts, and accessories for mounting and anchoring equipment.

- C. Construct supports of formed steel channel. Brace and fasten with flanges bolted to structure.

3.04 SLEEVES

- A. Exterior watertight entries: Seal with adjustable interlocking rubber links.

- B. Conduit penetrations not required to be watertight: Sleeve and fill with silicon foam.

- C. Set sleeves in position in forms. Provide reinforcing around sleeves.

- D. Size sleeves large enough to allow for movement due to expansion and contraction.

- E. Extend sleeves through floors 2 inch above finished floor level. Caulk sleeves.
- F. Where conduit or raceway penetrates floor, ceiling, or wall, close off space between conduit or raceway and adjacent work with stuffing or fire stopping insulation and caulk airtight. Provide close fitting metal collar or escutcheon covers at both sides of penetration.

3.05 TEST AND OPERATION

- A. Equipment:
 - 1. Thoroughly clean, lubricate, and protect from damage and dirt during operation.
 - 2. Test and operate in accordance with manufacturer's recommendations.
- B. The Contractor is responsible for connecting wiring and circuitry to all equipment furnished by others and the Contractor that requires electrical power or control.
- C. The Contractor shall demonstrate to the satisfaction of the Owner at final inspection that the wiring is complete and free from open circuits, short circuits between circuits or ground, and that systems operate satisfactorily. The entire electrical installation shall be demonstrated to operate in accordance with the specifications.

END OF SECTION

PART 1 - GENERAL

1.01 RELATED DOCUMENTS

- A. Drawings and general provisions of the contract, including General and Supplementary Conditions and Division 01 Specification sections, apply to this section. If differing requirements are identified elsewhere (in these specifications or on drawings or separate instructions), the more stringent requirement shall be met.

1.02 DESCRIPTION

- A. Work of this section includes wire and cable for all types of applications 600V and below.

1.03 SUBMITTAL

- A. Submit under provision of the project specifications.
- B. Provide voltage and insulation test data from the cable manufacturer.

1.04 DELIVERY, STORAGE, AND HANDLING

- A. Cable shall be on original reels or in boxes and shall be new and unused.
- B. Store cables in dry protected area and protect cable ends in accordance with manufacturer's recommendations.

PART 2 - PRODUCTS

2.01 LOW VOLTAGE, LIGHTING AND POWER CONDUCTORS

- A. Conductors provided on 120/208 and 277/480 volt power and lighting systems to be stranded per ASTM B-8 soft drawn copper.
- B. Insulation system shall be type THHN or THWN-2 rated 600V as defined and listed in Article 310 of NEC.
- C. Minimum size conductor utilized shall be #14 AWG for control circuits and #12 AWG for power and lighting circuits.
- D. Color code conductor insulation as follows:
 - 1. Line Voltage - Black
 - 2. Grounding Conductor - Green
 - 3. Neutral - White
 - 4. Control - Red
 - 5. DC Circuits - Blue
 - 6. Voltage from External Source - Yellow
 - 7. Color shall be integral with the insulation compound applied by cable manufacturer.

2.02 INSTRUMENTATION CABLES

- A. Instrumentation conductors shall be stranded copper conductors minimum size #18 AWG.
- B. Instrumentation conductors shall be paired and each pair twisted, and 100% shielded.
- C. Instrumentation cables shall have minimum 300 volt insulation on each conductor and have a jacket overall.
- D. Acceptable Manufacturers: Houston Wire and Cable, Belden, or Engineer approved.

2.03 TERMINAL BLOCKS:

- A. Provide 35mm DIN rail (channel) mount terminal blocks, as required, rated at 300V, 30A maximum, for interconnections with field equipment.
- B. Terminal blocks shall be sectional type, have white marking strip for numbered identification, connections, recessed screw heads compression clamp, test point and comb type jumper(s).
- C. Segregate terminal blocks used for DC signals, AC control and power wires.
- D. Power distribution blocks (PDB) shall be used as required for 480 V power distribution wiring within the panel, wireway or enclosure. Power distribution blocks shall be sized according to wiring requirements in the panel.
- E. Design based on Allen-Bradley, equal by Entelec, Panduit, Phoenix Contact, or Square D.

PART 3 - EXECUTION

3.01 LOW VOLTAGE LIGHTING AND POWER CABLES

- A. Install only after completion of work, which might cause damage to wires or conduit.
- B. Clean out or replace conduit in which dirt, water, concrete, or other foreign matter has been allowed to accumulate before installing wiring.
- C. Use THHN or tray rated cable and wire for routing in cable tray.
- D. Identify each end of each conductor by wire marking tape or sleeve. Mark on outer cover giving voltage, type, size, and circuit number.
- E. Splices:
 - 1. No wire splices allowed in entire length of conduit or raceway.
 - 2. Make splices in electrical enclosures.
 - 3. Splice Insulation: Equal to original factory insulation.
 - 4. Splicing Copper to Aluminum: Use aluminum-copper connections approved as suitable for the purpose.
- F. Termination of Conductors:
 - 1. Insulated type compression lugs.
 - 2. At distribution equipment containing aluminum bus bars, use aluminum copper lugs rated and approved for the application.
- G. Provide separate conduit for each type of circuit (power, controls, and communications).
- H. Conductors terminating at outlets shall be left not less than 8 inches long within outlet box.

3.02 INSTRUMENTATION CABLE

- A. Install only after completion of work which might cause damage to wires or conduit.
- B. Clean out or replace conduit in which dirt, water, concrete, or other foreign matter has been allowed to accumulate before installing wiring.
- C. Splices: No wire splices allowed in entire length of conduit or raceway.
- D. Provide separate conduit for instrumentation circuits.

- E. Mark on outer cover the control loop number at each end and each conductor the wire number by wire marking tape or sleeve.
- F. RF cable shall be installed in metal conduit.

3.03 FIREPROOFING OF CABLES

- A. Fireproofing of wires and cables shall be accomplished by half lapped taping using electrical arc and fireproofing tape made of heat resistant organic coated on one side with a flame retardant elastomer. The fireproofing tape shall be held in place by spiral wrapping at 18-inch intervals using pressure sensitive glass cloth tape 2 inches in width.

3.04 GROUPING OF CABLES

- A. Lace or plastic band groups of feeder conductors at distribution centers, pull boxes and wire ways.

3.05 WIRE PULLING

- A. Use wire pulling lubricant for pulling (No. 4 AWG) and larger wire. Do not pull cables through conduit with more than allowable bends specified in NEC 345-11. Only approved pulling compound suitable for the type wire insulation is allowed.

END OF SECTION

PART 1 – GENERAL

1.01 RELATED DOCUMENTS

- A. Drawings and general provisions of the contract, including General and Supplementary Conditions and Division 01 Specification sections, apply to this section. If differing requirements are identified elsewhere (in these specifications or on drawings or separate instructions), the more stringent requirement shall be met.

1.02 DESCRIPTION

- A. The work of this section includes equipment for an effective grounding system.

1.03 SUBMITTALS

- A. Submit under provisions of the project specifications.
- B. Certified ground resistance tests on each ground rod and the complete service system consisting of multiple rods and grounding conductor.
- C. Ground resistance tests on total systems.

1.04 STANDARDS

- A. IEEE Standard 142.
- B. NEC Article 250.

PART 2 - PRODUCTS

2.01 GROUNDING ELECTRODE

- A. Grounding electrode to be ground rods.
- B. Ground rods shall be bonded copper type steel core with thick copper covering inseparably bonded together 3/4" diameter x 10 ft length. Ground rod couplings are to be used if rod length of greater than 10 feet is required.

2.02 GROUNDING CONNECTIONS

- A. To be thermoweld when concealed or where required by Owner.
- B. To be mechanical where exposed to view.
- C. Where the grounding conductor penetrates a concrete surface use a 5/8 inch solid copperweld rod or a thermoweld antisiphon water stop.

2.03 GROUNDING ELECTRODE CONDUCTOR

- A. Grounding electrode conductor is to be as shown and sized in accordance with Table 250-66 of NEC.

2.04 EQUIPMENT GROUNDING CONDUCTORS

- A. Equipment grounding conductors shall be copper sized in accordance with Table 250-122 of NEC.

PART 3 - EXECUTION

3.01 INSTALLATION

- A. Ground resistance tests of each ground rod shall be made and results signed as correct by the Contractor.
- B. Provide grounding with ground rods of length required to achieve specified ground resistance of 25 ohms or less (per ground rod). Use three rods driven in triangle formation and connected in parallel. Provide ground rods at location shown (multiple rods may be required to achieve specified resistance).
- C. Bond the non-current carrying parts of all electrical equipment installed under this contract including metallic raceways, raceway supports, motors, equipment enclosures, and metallic cable sheaths by means of bare copper cable or copper strap to the station grounding system or as shown.
- D. All power, lighting over 120 volts and receptacle circuit conduits shall include a ground conductor sized per the NEC. Attach grounding conductors to equipment by means of approved copper alloy solderless grounding lugs or clamps which shall be secured to the equipment and the grounding point by means of hexhead cap screws or machine bolts after the contact surfaces have been cleaned to bright metal.
- E. Ground conductors run in conduit with circuit conductors are to be securely connected inside the junction boxes or enclosures. Splices in ground conductors shall be made by the "Cadweld" process by Erico Products, Inc., Continental Industries "Thermoweld", or equal.
- F. Support ground straps at intervals not exceeding two (2) feet by means of round head bronze machine screws and approved type anchors.
- G. Electrical grounding system in well houses are to be grounded to the metallic well casing.
- H. All circuits in non-metallic raceways shall include a ground conductor sized per the NEC or as shown. Attach grounding conductors to equipment by means of hexhead cap screws or machine bolts after the contact surfaces have been cleaned to bright metal. Ground conductors terminating at the motor control centers, switch gear to be terminated at the ground bus.

END OF SECTION

PART 1 - GENERAL

1.01 RELATED DOCUMENTS

- A. Drawings and general provisions of the contract, including General and Supplementary Conditions and Division 01 Specification sections, apply to this section. If differing requirements are identified elsewhere (in these specifications or on drawings or separate instructions), the more stringent requirement shall be met.

1.02 DESCRIPTION

- A. Work of this section includes electrical conduit systems.

1.03 SUBMITTALS

- A. Submit under provision of the project specifications.

1.04 RELATED WORK

- A. Section 26 05 34 - Electrical Boxes.

PART 2 - PRODUCTS

2.01 CONDUIT

- A. Rigid Metal Conduit (RMC):
 - 1. Unless otherwise detailed or specified elsewhere in the specifications or drawings, conduit for all locations shall be RMC.
 - 2. RMC shall be threaded, hot dipped galvanized inside and out conforming to UL Standard 6 and ANSI C80.1.
 - 3. Acceptable manufacturers: Allied Tube & Conduit, Republic, and Wheatland Tube.
- B. Intermediate Metal Conduit (IMC):
 - 1. IMC shall be galvanized, threaded, conforming to UL 1242 and ANSI C80.6.
 - 2. Intermediate metal conduit may be used in lieu of rigid steel conduit.
 - 3. Acceptable manufacturers: Allied Tube & Conduit, Republic, and Wheatland Tube.
- C. Electrical Metallic Tubing (EMT):
 - 1. Electrical metallic tubing (EMT) shall be galvanized, conforming to UL 797 and ANSI C80.3.
 - 2. Acceptable manufacturers: Robroy Industries; Perma-Cote, Plasti-Bond, Kor Kap and Thomas & Betts.
- D. Rigid Nonmetallic Conduit:
 - 1. Rigid nonmetallic conduit shall be PVC Schedule 40 or Schedule 80 heavy wall, rated for 90°C conductors and for use in direct sunlight conforming to UL 651 and Federal Specification W-C-1094A.
 - 2. Use only couplings and fittings designed specifically for the type of conduit noted. Follow the manufacturer's recommendations regarding the handling, bending, coupling and installation.
- E. Liquidtight Flexible Metal Conduit:
 - 1. Liquidtight Flexible Metal Conduit shall have flexible interlocking steel, spiral strip, galvanized with oilproof and waterproof flexible PVC jacket conforming to UL standards.
 - 2. For hazardous areas, provide explosion proof flexible conduit with insulated wire duct, threaded end fittings, bronze braid covering with flexible brass inner core, (overall neoprene protecting coating), in accordance with UL 886.

2.02 COUPLINGS AND CONNECTORS

- A. Provide rigid threaded galvanized compatible with galvanized rigid steel conduit.
- B. For intermediate metal conduits, provide IMC couplings galvanized, threaded, and of the same manufacturer.
- C. For electrical metal tubing, couplings and connectors to be steel set screw type, and of the same manufacturer. Couplings and connectors in the wet or unheated areas shall be steel compression type, and of the same manufacturer.
- D. Flexible conduit connectors shall be compression gland, liquid tight type.
- E. Connectors to metallic boxes or conversion to metallic conduit: Provide adapters as recommended by conduit manufacturer to provide a watertight threaded connection.
- F. intermediate metal conduits, provide IMC couplings galvanized, threaded, and of the same manufacturer.
- G. For rigid non-metallic PVC conduit, couplings to be PVC, liquid tight, suitable for the conduit with which the couplings are used and of the same manufacturer.
- H. Flexible conduit connectors shall be compression gland, liquid tight type.

2.03 FITTINGS

- A. UL listed.
- B. For metallic conduit, liquid tight, malleable iron alloy body and cover, zinc coated and stainless-steel screws.
- C. For nonmetallic conduit, liquid tight, utilizing the same non-metallic material as used in the conduit for body and the cover. Cover screws shall be stainless steel.

2.04 CLAMPS & HANGERS

- A. Hot dipped galvanized malleable iron straps with back spacers and hot dipped galvanized strap hangers with zinc plated threaded rods and hardware.
- B. PVC or other nonmetallic straps as recommended by the conduit manufacturer for the non-metallic conduit. Any metallic screws, bolts, nuts or other attachment hardware to be stainless steel.
- C. Trapeze type hangers shall be:
 - 1. For galvanized conduit, use galvanized steel channel support system with (zinc plated) threaded rod and hardware as manufactured by Super-Strut or Unistrut.
 - 2. For nonmetallic conduit, use fiberglass strut support system or PVC coated strut support system with plastic coated or stainless steel hardware.

PART 3 - EXECUTION

3.01 INSTALLATION

- A. Install the conduit in accordance with the manufacturer's recommendations. All buried conduits outside of buildings shall have locations marked on drawings. Minimum conduit size shall be 3/4". In no event shall the conduit size be less than required by National Electrical Code for the wire size and number indicated. Galvanized conduit shall not be painted except where shown.

- B. Utilization Areas:
1. Use RMC in all areas not described below.
 2. Use IMC in all above grade, dry areas unless described elsewhere.
 3. Use PVC Schedule 80 conduit for underground construction.
 4. Use PVC Schedule 40 conduit for under-ground-under-slab construction
 5. Use Electric Metallic Tubing (EMT) Conduit:
 - a. Wellhouse No. 1 (Interior)
 6. Use Liquidtight Flexible Metal Conduit for:
 - a. Motor terminations.
 - b. Termination to instrumentation and control field devices
- C. General Installation Guidelines:
1. Metal conduit systems shall be bonded to grounding systems.
 2. Run conduit parallel to or at right angles to building lines, except when in concrete slab or run under base slab. Support conduit at a maximum of 8 feet on center.
 3. Installation of conduit in concrete slabs and walls shall maintain two times (2x) the conduit diameter spacing between conduits. Maintain a distance of 3" from floor openings and wall penetrations. Maintain a minimum of 3" below all finished concrete surfaces.
 4. Bends for low voltage wiring shall be standard ells with a maximum equivalent of (4) four quarter bends in any run between pulling joints. Bends for medium voltage wiring shall be wide radius ells with a maximum equivalent of (3) three quarter bends in any run between pulling joints.
 5. Paint the ends of RMC/IMC joint couplings or threaded fittings with zinc rich coating of at least 90% purity zinc. Use cold galvanizing compounding ZRC Products Co. or Zinc-It or equal.
 6. Fasten all conduits entering boxes with locknut and bushing in the inside and locknut on the outside.
 7. Furnish and install Liquidtight Flexible Metal Conduit connections to all motors, solenoids and vibrating equipment. Conduit shall be a minimum 18 inches in length and shall be sufficiently long to enable motor to be moved to allow the disconnecting of the motor coupling without disconnecting the motor and shall be equipped with approved type grounding devices to ensure continuity between the conduit and the connection. In all cases, Liquidtight Flexible Metal Conduit runs shall not exceed 6 feet in total length.
 8. Clean all conduit thoroughly inside and outside after installation and just before pulling cables. All conduits not terminated in metal fittings or metal cabinets and secured with locknuts shall be terminated with grounding bushings.
 9. Install only undamaged conduit. Plug ends to prevent entry of dirt and moisture.
 10. Layout conduit routing to avoid structural obstructions and minimizing crossovers. Conduit runs must be installed in a neat and well planned arrangement and in a manner that will not interfere with access to equipment or with the use of accessways.
 11. Provide conduit sealing fittings and seal conduit with duct seal where conduits leave heated area and enter unheated area.
 12. Provide flashing and pitch pockets in making watertight joints where conduits pass through roof or waterproofing membranes.
 13. Install UL approved expansion fittings complete with grounding jumpers where conduits, metallic or non-metallic cross building expansion joints. Provide bends or offsets in conduit adjacent to building expansion joints where conduit is installed above suspended ceilings. In exposed PVC conduit runs longer than 50 feet, provide expansion couplings near boxes or devices. In exposed PVC conduit runs which do not have devices or boxes, an expansion coupling shall be installed for every 100 lineal feet of conduit.
 14. Whenever PVC is used, install a separate ground wire, and use rigid ells where exterior or poured concrete surfaces are penetrated. Also, provide rigid elbows where necessary to prevent "burn-through" of PVC conduit when pulling wire.
 15. Make transitions between nonmetallic conduits and conduits of other materials with the manufacturer's standard adapters designed for such purposes.

16. Conduit shall be securely attached to the building structure. Unless otherwise indicated, all electrical equipment shall be spaced at least 1/2 inch from the wall with hanger clamps to Unistrut, Super Strut, or equal.
 17. For single metallic conduit runs use galvanized conduit straps or ring bolt type hangers with specialty spring clips. Perforated strap is not allowed. Groups of conduits shall be supported on trapeze type hangers, Unistrut, or equal. Individual conduits not supported on conduit straps shall be provided with clevis type hangers. Hanger support shall be rod with threaded connections.
- D. Anchor Methods:
1. Hollow Masonry: Toggle bolts or spider type expansion anchors.
 2. Solid Masonry: Lead expansion anchors or preset inserts.
 3. Metal Surfaces: Machine screws, bolts, or welded studs.
 4. Wood Surfaces: Wood screws.
 5. Concrete Surfaces: Self-drilling anchors or power-driven studs.
- E. Conduit runs as indicated on drawings are schematic, exact routing of conduit to be approved by the Engineer. Make field bends and offsets uniform and symmetrical, without flattening conduit or scarring conduit finish and of minimum radius for each size as given in NEC Article 346.
- F. Conduit shall be as shown on plans and/or as required for the installation of outlets and devices shown on drawings. All conduits shall be supported from the structure or provided rods independent of all other trades. Proper location of conduits shall be the responsibility of the electrical contractor who shall avoid interferences with other trades.
- G. Install a pullwire in all empty conduits. All empty conduits installed for future use shall be capped or plugged and properly identified.
- H. Drains are required where it is probable that liquid or any condensed vapor may be trapped within enclosures, accumulated on seals, or accumulated at any point in the raceway system. All drains shall provide continuous draining. Drains shall be provided as follows:
1. At the low points of any conduit system where any portion between seals is outdoors or in a building without heating facilities. Note especially any vertical sealing fittings.
 2. At any control or wiring enclosure outdoors or in a building without heating facilities.

END OF SECTION

PART 1 - GENERAL

1.01 RELATED DOCUMENTS

- A. Drawings and general provisions of the contract, including General and Supplementary Conditions and Division 01 Specification sections, apply to this section. If differing requirements are identified elsewhere (in these specifications or on drawings or separate instructions), the more stringent requirement shall be met.

1.02 DESCRIPTION

- A. Work of this section includes junction boxes, pull boxes, and outlet boxes for interior, exterior, and hazardous locations.

1.03 RELATED SECTIONS

- A. Section 26 05 33 - Conduit.

PART 2 - PRODUCTS

2.01 JUNCTION, PULL, AND OUTLET BOXES

- A. All boxes used outdoors with rigid steel galvanized conduits shall have malleable iron body and cover with stainless steel screws. The finish shall be zinc electroplate and aluminum polymer enamel.
- B. All boxes used indoors with rigid steel galvanized conduits shall be pressed steel hot dip galvanized as specified in Part C below.
- C. Junction boxes set flush in exterior concrete slabs shall be hot dipped galvanized cast iron. Cover shall be same material as box with checkered plating design and neoprene gasket. Box shall be an O-Z Gedney Type Y-T or equal by Appleton. Box shall have a minimum 6" depth.
- D. Junction and pull boxes used with non-metallic conduits shall be (PVC).
- E. All boxes shall be UL listed and conforming to area classification. Boxes shall be NEMA 1 and NEMA 4X unless specified otherwise on drawings.

PART 3 - EXECUTION

3.01 INSTALLATION

- A. Clean interior of boxes of moisture, dirt, metal filings or other foreign matter.
- B. Assure that all conduit fittings that enter the box are tight and secure.
- C. Locate boxes in walls and on other surfaces as shown on the drawings.
- D. In hazardous areas use only explosion proof boxes.

END OF SECTION

PART 1 - GENERAL

1.01 RELATED DOCUMENTS

- A. Drawings and general provisions of the Contract, including General and Supplementary Conditions and Division 01 Specification Sections, apply to this Section. If differing requirements are identified elsewhere (in these Specifications or on drawings or separate instructions), the more stringent requirement shall be met.

1.02 DESCRIPTION:

- A. The work of this Section includes furnishing and installation of fiberglass-reinforced polymer handholes.

1.03 RELATED WORK:

- A. Section 260533 Conduit.

1.04 REFERENCES:

- A. ASTM D543, Test Method for Resistance of Plastic to Chemical Reagents.
- B. ASTM D570, Test Method for Water Absorption of Plastic.
- C. ASTM D635, Test Method for Rate of Burning and/or Extent of Burning of Self-Supporting Plastics in a Horizontal Position.
- D. ASTM D756, Practice for Determination of Weight and Shape Changes of Plastic Under Accelerated Service Conditions.
- E. ASTM D790, Test Method for Flexural Properties of Unreinforced and Reinforced Plastics and Electrical Insulating Materials.

PART 2 - PRODUCTS

2.01 FIBERGLASS REINFORCED POLYMER (FRP) HANDHOLES:

- A. The handhole boxes shall be constructed of high density fiberglass-reinforced polymer concrete with non-settling shoulders to maintain grade and facilitate backfilling shall meet or exceed a load rating of H/20. Dimensions shall be nominally 36" long x 24" wide x 18" deep. Provide extension pieces of same construction to attain required depth.
- B. The cover shall be a 3-piece checkered steel designed for roadway traffic applications (H/20 Rating). Cover shall have standard logo "ELECTRIC" or "COMMUNICATIONS", as applicable, with stainless steel penta-head bolt fasteners.
- C. Handholes and covers shall be TIER 15 rated for non-paved areas and TIER 22 for walks and areas where plow equipment may be utilized.
- D. Acceptable Manufacturer: Hubbell, Old Castle, or approved equal.

Project Name: Born Court Well 1-7
Project Number: 2220555

SECTION 26 05 44
HANDHOLES

PART 3 - EXECUTION

3.01 INSTALLATION:

- A. Fiberglass reinforced polymer concrete handholes shall be constructed in accordance with drawings. Provide sleeves for conduit entrance as shown on drawings.

END OF SECTION

PART 1 - GENERAL

1.01 RELATED DOCUMENTS

- A. Drawings and general provisions of the contract, including General and Supplementary Conditions and Division 01 Specification sections, apply to this section. If differing requirements are identified elsewhere (in these specifications or on drawings or separate instructions), the more stringent requirement shall be met.

1.02 SUMMARY

- A. This section includes electrical identification of electrical materials, equipment and installations. It includes requirements for electrical identification components including but not limited to the following:
 - 1. Buried electrical line warnings.
 - 2. Identification labeling for raceways, cables and conductors.
 - 3. Operational instruction signs.
 - 4. Warning and caution signs.
 - 5. Equipment labels and signs.
 - 6. Spare future conduits.
- B. Refer to other Division 26 sections for additional specific electrical identification associated with specific items.

1.03 SUBMITTALS

- A. Product Data: For each electrical identification product required on the project.

1.04 QUALITY ASSURANCE

- A. Comply with ANSI C2.
- B. Comply with NFPA 70.
- C. Comply with ANSI A13.1 and NFPA 70 for color coding.

PART 2 - PRODUCTS

2.01 CABLE LABELS

- A. Comply with ANSI A13.1, Table 3, for minimum size of letters for legend and for minimum length of color field for each raceway and cable size.
- B. Vinyl or vinyl-cloth, self-adhesive, wraparound, cable/conductor markers with preprinted numbers and letters.
- C. Color: Black letters on white field.
- D. Label Information: Indicate voltage and if applicable service.

2.02 NAMEPLATES AND SIGNS

- A. Safety Signs: Comply with 29 CFR, Chapter XVII, Part 1910.145.
- B. Engraved Plastic Nameplates and Signs: Engraving stock, melamine plastic laminate, minimum 1/16 inch thick for signs up to 20 sq. in, or 8 inches in length, and 1/8 inch thick for larger sizes.

- C. Color: Black letters on white face except for emergency systems listed in NFPA 70, Article 700, or as directed by the Owner.
- D. Nameplates shall be punched or drilled for mechanical fasteners.
- E. Exterior, Metal-Backed, Butyrate Signs: Weather-resistant, non-fading, preprinted, cellulose acetate butyrate signs with 0.0396-inch galvanized steel backing; and with colors, legend, and size required for the application. 1/4-inch grommets in corners for mounting.
- F. Fasteners for Nameplates and Signs: Self-tapping stainless steel screws or No. 10/32 stainless steel machine screws with nuts and flat and lock washers.

2.03 UNDERGROUND LABELS

- A. Underground line marking tape: Permanent, bright colored continuous printed plastic tape compounded for direct-burial service not less than 6 inches wide by 4 mils thick. Printed legend indicative of general type of underground line below.

2.04 MISCELLANEOUS IDENTIFICATION PRODUCTS

- A. Self-Adhesive Tape: Electronic label maker, imprinted, pressure-sensitive, abrasion resistant plastic tape.

PART 3 - EXECUTION

3.01 INSTALLATION

- A. General:
 - 1. Provide identification signs on all equipment enclosures, switches, breakers, panels, and enclosures.
 - 2. Attach nameplates directly to each piece of electrical equipment.
 - 3. Where several conductors pass through a pull box, junction box, or enclosure, provide wire labels. Group wires before labeling.
 - 4. Label shall indicate the following:
 - a. Equipment name.
 - b. Equipment voltage.
 - c. Equipment size.
 - d. Equipment feeder device and circuit #.
 - e. Additional items identified below.
- B. Service Disconnect(s):
 - 1. Label as "Service Disconnect".
 - 2. Multiple Service Disconnects: Each Service Disconnect shall list the total number and location of all other service disconnects in the facility.
 - 3. Service Voltage:
 - 4. Systems with generator(s) shall indicate that the system will become energized by a standby generator during a power outage and shall indicate the location of the generator.
- C. Panelboards:
 - 1. Name of device as indicated on one line diagram, voltage-phase, and upstream OCP location (example, "LPA, 208Y/120V-3Ø, FED FROM MCC-A").
 - 2. Provide a type written circuit identification schedule in each distribution or branch circuit panelboard under glass or plastic. Each circuit to be identified by load.

- D. Enclosed Switches, Enclosed Controllers (Motor Starters), and Variable Frequency Drives: Name of equipment served, load /size and upstream OCP location (example, "EF-5, 5 HP, FED FROM MDP-A").
- E. Motor Control Centers:
 - 1. Name of device as indicated on one line diagram, voltage-phase and upstream OCP location (example, "MCC-1, 480V-3Ø, FED FROM MDS").
 - 2. Provide label on each motor control center compartment identifying type of device, device rating, load served, and load characteristics (examples, "MOTOR STARTER, SIZE 1, P-1, 10 HP" or "CIRCUIT BREAKER, 3P20, HOIST, 1 TON"). Provide labels for spare devices and spaces.
- F. Transformers: Name of device as indicated on one line diagram, KVA rating, primary voltage: secondary voltage, source transformer is fed from, and load transformer feeds (example, "T LPA, 45 KVA, 480:208Y/120V, FED FROM MCC, FEEDS PANEL LPA").
- G. Transfer Switches shall be identified as "Emergency System" in white letters on red background.
- H. Existing nameplates on existing equipment that is reused are to be replaced.
- I. Identification Materials and Devices: Install at locations for most convenient viewing without interference with operation and maintenance of equipment in accordance with manufacturer's written instructions and requirements of NEC.
- J. Lettering, Colors, and Graphics: Coordinate names, abbreviations, colors, and other designations with corresponding specified or indicated. Install numbers, lettering, and colors as approved in submittals and as required by code.
- K. Identify high-voltage feeder conduits (over 600V) by words "DANGER-HIGH VOLTAGE KEEP OUT" in black letters 2 inches tall stenciled at 10-foot intervals over painted orange background.
- L. Sequence of Work: If identification is applied to surfaces that require finish, install identification after completing finish work.
- M. Self-Adhesive Identification Products: Clean surfaces before applying.
- N. Install nameplates and labels parallel to equipment lines.
- O. Identify junction, pull and connection boxes: Code required caution sign for boxes shall be pressure sensitive, self-adhesive label indicating system voltage in black, preprinted on orange background. Install on outside of box cover. Also label box covers with identity of contained circuits. Use pressure-sensitive plastic labels at exposed locations and similar labels or plasticized card stock tags at concealed boxes.
- P. All surface and flush mounted wiring devices (light switches, receptacles, etc.) shall have the power circuit identified in permanent marker or pen on the back (inside) of the device cover plate.
- Q. Underground electrical line identification: During trench backfilling for exterior underground power, signal and communication lines, install continuous underground plastic line marker located 12 inches directly above conduit. Where multiple lines installed in a common trench or concrete envelope do not exceed an overall width of 16 inches, install a single line marker.
- R. Labeling Legend: List panel and circuit number or equivalent in a legible manner.
- S. Color Coding of Secondary Phase Conductors: Refer to Section 26 05 19.

- T. Wiring for control systems shall be color coded in accordance with wiring diagrams furnished with the equipment.
- U. Tag or label conductors as follows:
1. Future connections: Conductors indicated to be for future connection or connection under another contract with identification indicating source and circuit numbers.
 2. Multiple circuits: Where multiple branch circuits or control wiring or communications/signal conductors are present in the same box or enclosure (except for three-circuit, four-wire home runs), label each conductor or cable. Provide legend indicating source, voltage, circuit number, and phase for branch circuit wiring. Phase and voltage of branch circuit wiring may be indicated by means of coded color of conductor insulation. For control and communication/signal wiring, use color coding or wire/cable marking tape at terminations and at intermediate locations where conductors appear in wiring boxes, troughs and control cabinets. Use consistent letter/number conductor designations throughout on wire/cable marking tapes.
- V. Factory apply color the entire length of conductors, except the following field applied color coding methods may be used instead of factory coded wire for sizes larger than No. 10 AWG.
- W. Colored, pressure-sensitive plastic tape in half-lapped turns for a distance of 6 inches from terminal points and in boxes where splices or taps are made. Apply last two turns of tape with no tension to prevent possible unwinding. Use 1-inch wide tape in colors specified. Adjust tape bands to avoid obscuring cable identification markings.
- X. Warnings, Cautions, and Instructions: Install to ensure safe operation and maintenance of electrical systems and of items to which they connect. Install engraved plastic-laminated instruction signs with approved legend where instructions are needed for system or equipment operation. Install metal-backed butyrate signs for outdoor items.
- Y. Emergency Operation: Install engraved laminated signs with white legend on red background with minimum 3/8 inch high lettering for emergency instructions on power transfer, load shedding, and other emergency operations.
- Z. Switch Identification Labels: Self-Adhesive Tape. Install on each switch when there are more than two switches under one faceplate or if switches are used to control exhaust fans or other equipment. Unless otherwise indicated, provide a single line of text with 1/8-inch high black lettering on clear background. Label shall indicate load controlled.
- AA. Apply circuit/control/item designation labels of engraved plastic laminate for disconnect switches, breakers, pushbuttons, pilot lights, motor control centers and similar items for power distribution and control components above, except panelboards and alarm/signal components, where labeling is specified elsewhere. For panelboards, provide framed, typed circuit schedules with explicit description and identification of items controlled by each individual breaker.
- BB. Furnish and install a sign at the service entrance equipment indicating type and locations of onsite emergency power sources. Sign shall be 8x10-inch minimum size mounted on the face on the switchboard.
- CC. Provide suitable permanent means of labeling spare conduits. Provide legible means of identifying the location of where each conduit originates. Provide the same identification at each end.
- DD. Equipment Identification Labels: Engraved plastic laminate. Install on each unit of equipment, including central or master unit of each system. This includes power, lighting, communication, signal, and alarm systems, unless units are specified with their own self-explanatory identification. Unless otherwise indicated, provide a single line of text with 1/2 inch high lettering on 1-1/2 inch high label. Where two lines of text are required, use labels 2 inches high. Use black lettering on white field. Apply labels for each unit of the following categories (not all categories may be required on the project) of equipment using mechanical fasteners:

SECTION 26 05 53
ELECTRICAL IDENTIFICATION

1. Panelboards, electrical cabinets, and enclosures. Include series rated labeling if required.
2. Access doors and panels for concealed electrical items.
3. Electrical switchgear and switchboards. Include series rated labeling if required.
4. Emergency system boxes and enclosures.
5. Motor control centers.
6. Disconnect switches.
7. Enclosed circuit breakers.
8. Motor starters.
9. Pushbutton stations.
10. Contactors.
11. Remote controlled switches.
12. Control devices.
13. Transformers.
14. Variable frequency drives.
15. Power generating units.
16. Timers/time clocks.

END OF SECTION

PART 1 - GENERAL

1.01 SCOPE

- A. The Contractor shall furnish and install single-phase and three-phase general purpose individually mounted mini-power centers of the two-winding type, self-cooled, as specified herein and as shown on the contract drawings.

1.02 REFERENCES

- A. The mini-power center and all components shall be designed, manufactured and tested in accordance with the latest applicable standards of UL, ANSI and NEMA.

1.03 SUBMITTALS

- A. The following information shall be submitted to the Engineer:
1. Dimension drawing weights
 2. Transformer ratings including:
 - a. kVA
 - b. Primary and secondary voltage
 - c. Taps
 - d. Primary and secondary continuous current
 - e. Insulation class and temperature rise
 - f. Sound level
 3. Component ratings including:
 - a. Voltage
 - b. Continuous current
 - c. Interrupting ratings
 4. Cable terminal sizes
 5. Product data sheets.
- B. The following information shall be submitted for record purposes after construction:
1. Final (as-built) drawings and information for items listed in above in Item A, and shall incorporate all changes made during the manufacturing process
 2. Connection diagrams
 3. Installation information

1.04 QUALIFICATIONS

- A. The manufacturer of the assembly shall be the manufacturer of the electrical distribution equipment.
- B. For the equipment specified herein, the manufacturer shall be ISO 9001 or 9002 certified.
- C. The manufacturer of this equipment shall have produced similar electrical equipment for a minimum period of five (5) years.

1.05 REGULATORY REQUIREMENTS

- A. The assembly and all components shall be U.L. listed.

1.06 DELIVERY, STORAGE AND HANDLING

- A. Equipment shall be handled and stored in accordance with manufacturer's instructions. One (1) copy of these instructions shall be included with the equipment at time of shipment.

1.07 OPERATION AND MAINTENANCE MANUALS

- A. Equipment operation and maintenance manuals shall be provided with each assembly shipped and shall include instruction leaflets and instruction bulletins for the complete assembly and each major component.

PART 2 – PRODUCTS

2.01 MANUFACTURERS

- A. Eaton, Square D, Siemens, GE or equal.
- B. The listing of specific manufacturers above does not imply acceptance of their products that do not meet the specified ratings, features and functions. Manufacturers listed above are not relieved from meeting these specifications in their entirety. Products in compliance with the specification and manufactured by others not named will be considered only if pre-approved by the Engineer ten (10) days prior to bid date.

2.02 RATINGS

- A. kVA and voltage ratings shall be as shown on the drawings.
- B. Units shall be designed for continuous operation at rated kVA, for 24 hours a day, 365 days a year operation, with normal life expectancy as defined in ANSI C57.96.
- C. Transformer sound levels shall not exceed the following ANSI and NEMA levels for self-cooled ratings:
 - 1. Up to 9 kVA: 40 dB
 - 2. 10 to 30 kVA: 45 dB

2.03 CONSTRUCTION

- A. Each mini-power center shall include a primary main breaker, an encapsulated dry-type transformer and a loadcenter with secondary main breaker.
- B. Primary main, secondary main and feeder breakers shall be enclosed with a padlockable hinged door.
- C. Insulation Systems
 - 1. Transformers shall be insulated with a 180° C insulation system and rated at 115° C temperature rise.
 - 2. Required performance shall be obtained without exceeding the above-indicated temperature rise in a 40° C maximum ambient, with a 30° C average over 24 hours.
 - 3. All insulation materials shall be flame-retardant and shall not support combustion as defined in ASTM Standard Test Method D635.
- D. Core and Coil Assemblies
 - 1. Transformer core shall be constructed with high-grade, non-aging, silicon steel with high magnetic permeability, and low hysteresis and eddy current losses. Maximum magnetic flux densities shall be substantially below the saturation point. The transformer core volume shall allow efficient transformer operation at 10% above the nominal tap voltage. The core laminations shall be tightly clamped and compressed. Coils shall be wound of electrical grade aluminum [copper optional] with continuous wound construction.
 - 2. The core and coil assembly shall be completely encapsulated in a proportioned mixture of resin and aggregate to provide a moisture proof, shock-resistant seal. The core and coil encapsulation system shall minimize the sound level.
 - 3. The core of the transformer shall be grounded to the enclosure.
 - 4. Provide two (2) 5% FCBN taps.

2.04 BUS

- A. Secondary bus shall be aluminum or copper.

2.05 WIRING/TERMINATIONS

- A. All interconnecting wiring between the primary breaker and transformer, secondary main breaker and transformer and distribution section shall be factory installed.
- B. All transformers shall be equipped with a wiring compartment suitable for conduit entry and large enough to allow convenient wiring.

2.06 MAIN DEVICES

- A. Each mini-power center shall include a primary main breaker with an interrupting rating of 14 kA at 277/480 volts; and a secondary main breaker with an interrupting rating of 10kA at 120/240 volts, and a loadcenter.

2.07 FEEDER DEVICES

- A. The secondary distribution section shall accommodate plug-in breakers or bolt-on breakers with 10 kA interrupting capacity.

2.08 ENCLOSURE

- A. The enclosure shall be made of heavy-gauge steel and the maximum temperature of the enclosure shall not exceed 90° C.
- B. The enclosure shall be totally enclosed, nonventilated, NEMA 3R, with lifting provisions.

2.09 WARRANTY

- A. Product shall have standard 18 month warranty.

PART 3 - EXECUTION

3.01 FACTORY TESTING

- A. The following standard factory tests shall be performed on the equipment provided under this section. All tests shall be in accordance with the latest version of ANSI and NEMA.
 1. Ratio tests at the rated voltage connection and at all tap connections
 2. Polarity and phase-relation tests on the rated voltage connection
 3. Applied potential tests
 4. Induced potential test
 5. No-load and excitation current at rated voltage on the rated voltage connection.

3.02 INSTALLATION

- A. The Contractors shall install all equipment per the manufacturer's recommendations and the contract drawings.

3.03 FIELD ADJUSTMENTS

- A. Adjust taps to deliver appropriate secondary voltage.

3.04 FIELD TESTING

- A. Measure primary and secondary voltages for proper tap settings.

Project Name: Born Court Well 1-7
Project Number: 2220555

SECTION 26 24 18
MINI POWER CENTERS

END OF SECTION

PART 1 - GENERAL

1.01 RELATED DOCUMENTS

- A. Drawings and general provisions of the contract, including General and Supplementary Conditions and Division 01 Specification sections, apply to this section. If differing requirements are identified elsewhere (in these specifications or on drawings or separate instructions), the more stringent requirement shall be met.

1.02 DESCRIPTION

- A. Work of this section includes fuses and fuse holders.

1.03 SUBMITTALS

- A. Submit under provision of the project specifications.
- B. Product data.
- C. Time current curves and current limitation curves for fuses.

PART 2 - PRODUCTS

2.01 GENERAL

- A. All fuses shall be UL listed current limiting type with high interrupting capacity.
- B. All fuse contact surfaces shall be plated.
- C. Fuses shall be selected to provide a fully selective system.

2.02 MANUFACTURERS

- A. Fuses shall be Gould Shawmut or Bussmann.

2.03 TRANSFORMER PROTECTION FUSES

- A. Low Voltage (600 VAC or less):
 - 1. Above 600A: Provide Class L fuses for low voltage transformers rated above 600A.
 - 2. 600A or less: Provide Class RK5, time delay type fuses for low voltage transformers rated 600A or less.
 - 3. All fuses shall have 200,000 amperes RMS interrupting rating.
- B. Control Circuit (600 VAC or less): Provide Class CC for control circuit transformers rated 600 VAC or less. Fuses shall have 200,000 amperes RMS interrupting rating.

2.04 MOTOR PROTECTION FUSES

- A. Low Voltage (600 VAC or less): Provide time delay type, Class RK-5 (if more current limitation is required, provide Class RK-1 or Class J) fuses for short circuit protection of low voltage motors and motor controllers. Fuses shall have 200,000 amperes RMS interrupting rating.

2.05 MAIN CIRCUIT PROTECTION FUSES

- A. Above 600 A: Provide Class L fuses for service entrance and feeder circuits rated above 600 A.
- B. 600 A or less: Provide Class J or Class RK1 time delay type fuses for service entrance and feeder circuit rated 600 A or less.

- C. All fuses shall have 200,000 amperes RMS interrupting rating.

2.06 FUSE HOLDERS

- A. Wire connectors shall be box type - most durable and versatile for stranded or solid wire.
- B. Fuse block insulators shall be molded polycarbonate type. All insulators shall meet voltage clearance and creepage requirements of UL for general industrial control equipment.
- C. Fuse clips shall be standard clips - cover all ratings 30-600 amperes spring reinforced with rejection feature for Class R fuses.

PART 3 - EXECUTION

3.01 INSTALLATION

- A. Fuses to be properly mounted or bolted into their fuse holder so as to maintain proper continuity.
- B. Fuses and fuse holders shall be sized according to the NEC.
- C. Coordination with other protective devices shall be accomplished by using proper time-current curves.

END OF SECTION

PART 1 – GENERAL

1.01 RELATED DOCUMENTS

- A. Drawings and general provisions of the contract, including General and Supplementary Conditions, Project Specifications, and Division 01 specification sections, apply to this section. If differing requirements are identified elsewhere (in these specifications or on drawings or separate instructions), the more stringent requirement shall be met.

1.02 DESCRIPTION

- A. Work of this section includes motor and general circuit disconnects including separately mounted disconnects and those mounted in motor control centers.

1.03 RELATED SECTIONS

- A. Section 26 28 13 - Fuses

1.04 SUBMITTALS

- A. Submit under provision of the Project Specifications.
- B. Provide shop drawings and product data for disconnects including outline and mounting dimensions, wiring schematic diagrams, short circuit current withstand ability ratings.
- C. Provide operational and maintenance data including renewal parts for all disconnects.

PART 2 - PRODUCTS

2.01 DISCONNECT SWITCHES

- A. Provide disconnect switches with switch blades fully visible in "OFF" position, rated NEMA Type HD, Underwriters Laboratory listed, with quick-make, quick-break operation handle, and mechanism forming an integral part of the box, not in the cover. All current carrying parts shall be plated to resist corrosion and have cool operation. The switches to have dual cover interlock to prevent unauthorized opening of door in the "ON" position or closing switch with door open. Provide padlocking provisions to allow at least three (3) padlocks to prevent switch operation in the "OFF" position. Provide safety switches, fused, non-fused to horsepower rated, as required.
- B. Switches shall be padlockable in open and closed positions.
- C. Provide fusible disconnect switches with clips for fuses which have UL listed short circuit rating of 200,000 rms symmetrical amperes when Class R or Class J fuses are used.
- D. In outdoor or wet locations areas the disconnect switch enclosures and operators shall be painted mild steel with stainless steel hardware. Switches shall be NEMA 3R rated.
- E. Disconnect switches shall be provided with mechanical type lugs suitable for the conductors used.
- F. Acceptable Manufacturers:
 - 1. Square D, Eaton Cutler-Hammer, or approved equal.

PART 3 - EXECUTION

3.01 INSTALLATION

Project Name: Born Court Well 1-7
Project Number: 2220555

SECTION 26 28 16
MOTOR & CIRCUIT DISCONNECTS

- A. Install motor and circuit disconnects in accordance with manufacturer's recommendations and applicable codes.
- B. Provide fuses of required rating in each fused switch.
- C. Inspect all disconnect devices for damage. Verify operation of the disconnect prior to energizing or adding load.

END OF SECTION

PART 1 – GENERAL

1.01 RELATED DOCUMENTS

- A. Drawings and general provisions of the contract, including General and Supplementary Conditions and Division 01 Specification sections, apply to this section. If differing requirements are identified elsewhere (in these specifications or on drawings or separate instructions), the more stringent requirement shall be met.

1.01 DESCRIPTION

- A. Work of this section includes circuit breakers and their related enclosures.

1.02 RELATED SECTIONS

- A. Section 26 24 16 - Panelboards.
- B. Section 26 24 19 - Motor Control Centers.
- C. Section 26 32 13 - Gas Engine Generators.

1.03 SUBMITTALS

- A. Submit under provision of the project specifications.
- B. Product data including applicable shop drawings.

PART 2 - PRODUCTS

2.01 MATERIALS

- A. Molded Case Circuit Breakers:
 - 1. 120, 208, 277, 480 volt.
 - 2. 50, 100, 250, 400 ampere frame.
 - 3. 15 through 400 continuous ampere rating.
 - 4. Thermal magnetic trip unit.
 - 5. 1, 2, and 3 pole.
 - 6. Interrupting current rating as noted on the schedules.
 - 7. Ground fault interrupters with 4-6 mA sensitivity.
 - 8. Trip free mechanism.
 - 9. Quick make, quick break mechanism.
 - 10. Plug-in line bus connected.
- B. Options Available for Circuit Breakers:
 - 1. Line and load lugs suitable for use with copper conductors with standard copper pressure, set screw fastening, aluminum alloy, terminals.
 - 2. Mechanical interlocking of walking beam or sliding bar type.
 - 3. Enclosure of NEMA Type 1.

PART 3 - EXECUTION

3.01 INSTALLATION

- A. Circuit breakers to be mounted in enclosures, panels, load centers, motor control centers, or switchgear.
- B. Enclosure for circuit breaker shall be properly grounded.

SECTION 26 28 17
CIRCUIT BREAKERS

- C. Attach handles so as to not interfere with cover plate or door.
- D. Properly mount circuit breaker so acceptable electrical connection is made to bus work.
- E. Terminations to breaker terminals shall be to industry standards.

END OF SECTION

PART 1 - GENERAL

1.01 RELATED DOCUMENTS

- A. Drawings and general provisions of the contract, including General and Supplementary Conditions and Division 01 Specification sections, apply to this section. If differing requirements are identified elsewhere (in these specifications or on drawings or separate instructions), the more stringent requirement shall be met.

1.02 DESCRIPTION

- A. The work of this section includes separately mounted motor starters.

1.03 SUBMITTALS

- A. Submit under provision of per requirements of Division 1.
- B. Provide shop drawings for motor starters separately mounted including outline and wiring diagrams.
- C. Provide Product Data including:
 - 1. Outline mounting dimensions and wiring diagrams.
 - 2. Component layout.
 - 3. Motor starter contactor.
 - 4. NEMA starter size.
 - 5. Control transformer.
 - 6. Overload relay.
 - 7. Overcurrent disconnects device data.
 - 8. Push buttons, selector switches and pilot lights.
- D. Provide operation and maintenance data including renewal parts for all starters. Include listing of each application showing motor nameplate details, starter size and type and overload heater sizing.

PART 2 – PRODUCTS

2.01 ACCEPTABLE MANUFACTURERS

- A. Square D, Eaton, Allen-Bradley, or engineer approved equal.

2.02 COMBINATION MOTOR STARTERS

- A. Starter contactor shall be NEMA type as shown on the drawings. Refer to minimum NEMA rating requirements for enclosures listed in Section 262816 Motor & Circuit Disconnects. The NEMA rating of the enclosure shall match the rating of the area.
- B. Provide with motor circuit protector with ratings as shown on the drawing. Provide flange-mounted disconnect with padlocking in "OFF" and "ON" positions. Operating voltage shall be 480 volt, 3 phase unless noted otherwise.
- C. Starter shall have double break silver alloy contacts through NEMA size 3, which shall be replaceable without removing any power wiring or the starter.

- D. Coils to be encapsulated type construction through NEMA size 5 (and form wound taped, varnished and baked on NEMA size 6 and larger), replaceable from the front without removing the starter.
- E. Provide a solid-state adjustable overload relay. Overload relay shall be equipped with a manual reset, test and stop buttons. Relay shall be manually reset from front of starter enclosure and shall be "Trip Free" not allowing the overload relay control contacts to reclose or render harm to the motor load or starter. The relay shall be ambient insensitive within an operating temperature range to -20 to +70°C. They shall provide built in thermal memory to prevent hot motor restarts. Relay shall provide current unbalance and ground fault protection for the motor. Relay shall have selectable starting class ratings.
- F. Shall have suitable space for the addition of auxiliary contacts of any arrangement of normally open or normally closed and shall accept 4 contacts. These contacts shall be in addition to the normal "seal in" contact. Auxiliary contacts, which shall be provided, are as follows 2-NO and 2-N.C.
- G. Provide a 30-mm, three-position Hand-Off-Auto selector switch, elapsed time indicator, and 30 mm LED transformer type run pilot light on the front of the enclosure unless indicated otherwise.
- H. Provide a control power transformer of ample capacity (minimum 50VA) to operate the control circuit at 120 volt. Control transformer shall include two primary fuses and one secondary fuse.
- I. Provide elapsed time meter:
 - 1. Odometer style, non-resettable 6-digit display.
 - 2. Designed for panel mount application.
 - 3. Accurate to 0.025 percent.
- J. Control circuits and relays shall be provided as shown on drawings with contacts rated not less than 120 volts, 10 amperes.
- K. Mechanical interlocks shall be provided to prevent access to inside of starter cabinet by unauthorized personnel when switch is in "ON" position.
- L. All field wiring to be connected to terminal blocks in starter enclosure, provide 10 percent spare for future use, 4 minimum. Designate spare terminals in wiring diagram.

PART 3 - EXECUTION

3.01 INSTALLATION

- A. Install in accordance with manufacturer recommendations and applicable codes. Configure overload relays to provide proper motor overload protection in accordance with NEC considering motor service factor, temperature rise, ambient temperatures and other applicable factors. Configure restart time delay to "stagger" equipment restart on return to power after power failure.
- B. Connect controls in accordance with wiring diagrams.

3.02 VISUAL AND MECHANICAL INSPECTION

- A. Document equipment nameplate data on test report. Verify equipment nameplate ratings are in accordance with drawings and specifications. This will include contactor, fuses, overloads, circuit breakers, overload relay heaters, and the control power transformer.
- B. Inspect the physical and mechanical condition of the equipment.

3.03 ELECTRICAL TESTS

- A. Perform operational tests by initiating control devices.
- B. Verify proper phase rotation of motor load and swap conductors on control contactor as required.

END OF SECTION

PART 1 - GENERAL

1.01 RELATED DOCUMENTS

- A. Drawings and general provisions of the contract, including General and Supplementary Conditions and Division 01 Specification sections, apply to this section. If differing requirements are identified elsewhere (in these specifications or on drawings or separate instructions), the more stringent requirement shall be met.

1.02 RELATED DOCUMENTS

- A. Provide surge protection devices as depicted and described in the contract documents.

1.03 DESCRIPTION

- A. General: Surge protection device (SPD) is the description and equipment required for the protection of all AC electrical circuits and electronic equipment from the effects of lightning induced voltages, external switching transients and internally generated switching transients.

1.04 RELATED WORK:

- A. Section 26 05 34 - Electrical Boxes.

1.05 REFERENCE STANDARDS AND PUBLICATIONS

- A. General: The latest edition of the following standards and publications shall comply to the work of this section:
 1. ANSI/IEEE C84.1-1989, American National Standard for Electric Power Systems and Equipment - Voltage Ratings (60 Hertz)
 2. ANSI/IEEE C62.41-1991, Recommended Practice on Surge Voltages in Low-Voltage AC Power Circuits
 3. ANSI/IEEE C62.45-1992, IEEE Guide on Surge Testing for Equipment Connected to Low-Voltage AC Power Circuits
 4. Underwriters Laboratories UL 1449 Third Edition, Standard for Safety - Transient Voltage Surge Suppressors
 5. Underwriters Laboratories, UL 1283, Standard for Safety - Electromagnetic Interference Filters
 6. National Fire Protection Association, NFPA 780 - National Electrical Code
 7. IEEE Standard 142-1991, IEEE Recommended Practice for Grounding of Industrial and Commercial Power Systems (IEEE Green Book)
 8. ANSI/IEEE Standard 141-1999, IEEE Recommended Practice for Electric Power Distribution for Industrial Plants (IEEE Red Book)
 9. IEEE Standard 1100-1999, IEEE Recommended Practice for Powering and Grounding Sensitive Electronic Equipment (IEEE Emerald Book)
 10. FIPS Pub 94, Federal Information Processing Standards Publication - Guideline on Electrical Power for ADP Installations
 11. National Electrical Manufacturer's Association LS-1, 1992 (NEMA LS-1)
 12. MIL Standard 220A Method of Insertion-loss Measurement
 13. ISO 9001:1994, Quality Systems - Model for Quality Assurance in Design, Development, Production, Installation and Servicing

1.06 QUALITY ASSURANCE

- A. The manufacturer shall submit a written statement indicating that a factory authorized representative inspected the installation. The installing contractor shall submit a check-out memorandum to the manufacturer. The memorandum shall indicate the date the equipment is placed into service and the actual method of installation. Submit three copies to the specifying Engineer.

- B. The manufacturer must be regularly engaged in the manufacture of surge suppression products for the specified categories for no less than ten (10) years.

1.07 WARRANTY

- A. The SPD and supporting components shall be guaranteed by the manufacturer to be free of defects in material and workmanship for a period of 20 years from the date of substantial completion of service and activation of the system to which the suppressor is attached.
- B. Warranty is to cover the effects of lightning, single phasing, and all other electrical anomalies. The warranty shall cover the entire device, not just various components such as modules only.
- C. The installation of SPDs in or on electrical distribution equipment shall in no way compromise the equipment listing, labeling, or warranty of the distribution equipment.

1.08 SUBMITTALS

- A. Submit under provisions of the project specifications.
- B. The transient voltage surge suppression submittals shall include, but shall not be limited to, the following information:
 - 1. Data for each suppressor type indicating conductor sizes, conductor types, and connection configuration and lead lengths.
 - 2. Manufacturer's certified test data indicating the ability of the product to meet or exceed requirements of this specification.
 - 3. Drawings, with dimensions, indicating SPD mounting arrangement and lead length configuration, and mounting arrangement of any optional remote diagnostic equipment and assemblies.
 - 4. List and detail all protection systems such as fuses, disconnecting means and protective materials.
 - 5. SPD wiring, bonding, and grounding connections shall be indicated on the wiring diagrams for each system. Include installation details demonstrating mechanical and electrical connections to equipment to be protected.

PART 2 - PRODUCTS

2.01 ACCEPTABLE MANUFACTURERS

- A. Surge Protection Devices shall be by the following or approved equal. Manufacturers requesting product approval must meet the written specification contained herein.
 - 1. Liebert. SI series with Accuguide Cable.
 - 2. Siemens.
 - 3. GE/ABB.
 - 4. Eaton Electrical Inc.
 - 5. Raycap Inc.
 - 6. Square D.

2.02 GENERAL REQUIREMENTS

- A. SPDs shall be listed in accordance with UL 1449 3rd Edition, Type 1 for Type 1 and Type 2 locations and UL 1283, Standard for Safety, Electromagnetic Interference Filters.
- B. The SPD shall protect all modes and there shall be seven discrete suppression circuits: 3 modes connected Line to Ground, 3 modes connected Line to Neutral, and 1 mode connected Neutral to Ground for a 3-phase, 4-wire, plus ground voltage system. Line to Neutral to Ground is not an acceptable substitute for Line to Ground. Line to Neutral to Line and Line to Ground to Line (in combination) will be acceptable for Line to Line protection.
- C. All SPDs must have passed the UL 1449 3rd Edition Fault Current Test with a Rating of 200,000 AIC. Documentation substantiating this claim must be provided.

- D. SPDs shall use a separate path to building ground; the equipment safety ground is not to be used as a transient ground path.
- E. All power system SPDs are to be MOV based and not included SAD technology as a means of suppression.
- F. The maximum continuous operating voltage (MCOV) of all components shall not be less than 125% for a 120V system and 115% for 220, 240, 277, and 480V systems.
- G. Standard diagnostic features are to include green LEDs (one per phase - normally on) indicating power and suppression status and a Form C dry relay contact.
- H. Extended diagnostics must include an audible alarm and surge counter to be displayed on an LCD display on the front of the suppressor. The surge counter must include a reset option. The audible alarm must include a mute option. Products requiring diagnostic test kits will not be acceptable.
- I. SPDs shall be of compact design. The mounting position of the SPD shall allow a straight and short lead-length connection between the SPD and the point of connection in the panelboard.
- J. Visual indication of proper SPD connection and operation shall be easily viewed on the front panel of the enclosure. The indicator lights shall indicate suppression circuit status, phase status, phase loss, reduced protection level and suppression fault.
- K. The SPD shall be equipped with an integral disconnect switch.
- L. A set of normally open/normally closed Form C dry contacts shall be provided for remote monitoring.
- M. The enclosure type shall have a minimum of a NEMA 12 rating.
- N. SPDs shall have a diagnostics LCD panel display providing information on phase loss (specific to each phase), surge/transient event count, stored cumulative surge/transient event history, and technical support information.
- O. SPDs shall be equipped with an audible alarm with mute, reset, and acknowledge features.
- P. The device must be certified (report to be submitted) to withstand a minimum of 20,000 Category C3 (Combination wave - 20,000 Volts - 1.2x50 :s OCV and 10,000 Amps - 8x20 :s SCC as defined by ANSI/IEEE C62.41-1991) impulses with less than 10% change in the baseline to final let-through voltage. This data must be submitted as an independently verified and certified test report.
- Q. Unit shall have component level fusing integral to the SPD for over current protection.
- R. The maximum value for the attenuation for the suppressor must exceed a minimum of 33 dB. All measurements for this requirement must be taken using the MIL STD 220A method and with only six (6) inches of lead length extending outside of the normal exit location of leads for the enclosure.

2.03 PROTECTION REQUIREMENTS

- A. SPD shall provide protection for all modes of protection (L-L, L-N, L-G & N-G).
- B. Response time of SPD to a surge shall be less than one nanosecond.
- C. Maximum rated surge current: 160 kA per phase / 80 kA per mode.

PART 3 – EXECUTION

3.01 INSTALLATION

- A. The installing contractor shall install the parallel SPD with short and straight conductors as practically possible.

Project Name: Born Court Well 1-7
Project Number: 2220555

SECTION 26 43 13
SURGE PROTECTION DEVICES

- B. The contractor shall follow the SPD manufacturer's recommended installation practice as found in the equipment installation instructions.
- C. The installation shall meet the requirements of all applicable codes.

END OF SECTION

Project Name: Born Court Well 1-7
Project Number: 2220555

ELECTRICAL SPECIFICATIONS
DIVISION 27
TABLE OF CONTENTS

SECTION	TITLE
27 20 00	Data Communications

PART 1 – GENERAL

1.01 RELATED DOCUMENTS

- A. Drawings and general provisions of the contract, including General and Supplementary Conditions and Division 01 specification sections, apply to this section. If differing requirements are identified elsewhere (in these specifications or on drawings or separate instructions), the more stringent requirement shall be met.

1.02 DESCRIPTION OF WORK

- A. Establish ethernet communication between the proposed Born Court Well 1-7 control panel and the existing Water Treatment Facility. Communication systems include Category 6 copper cabling and fiber optic cabling.
- B. Extent of work shall include but not limited to the following:
 - 1. Communication equipment mounted in PLC control panels.
 - 2. Ethernet media converters & switches, and Category 6 (Cat 6) UTP cabling.
 - 3. Fiber optic cabling, patch panels and fiber terminations
 - 4. Startup and commissioning of communication system.

1.03 RELATED SECTIONS

- A. Section 26 05 00 - Electrical General Provisions
- B. Section 26 05 33 – Conduit
- C. Section 26 05 34 – Electrical Boxes
- D. Section 40 95 10 – Lift Station Control Panels

1.04 SUBMITTALS

- A. Submit under provision of Section 01 33 00 - Submittals.
- B. Itemized Listings:
 - 1. Description of deviations from the requirements of this Section.
 - 2. Re-submittals shall contain response(s) to each comment made by Engineer.
- C. Shop drawing submittal material shall be project specific.
- D. Submit test report for installed all fiber optic cabling.

PART 2 – PRODUCTS

2.01 DATA INFRASTRUCTURE WIRING

- A. Unshielded Twisted Pair (UTP) Cabling For Voice/Data.
 - 1. UL verified to Category 6 and rated for minimum 1000MB/sec.
 - 2. Paired, 4 pair, 23 AWG, solid bare copper conductors with polypropylene insulation PVC jacket. Outer jacket shall be blue.
 - 3. Manufacturer: Belden 2413A; or equal.
 - 4. Provide plenum rated cable where installed exposed.
 - 5. For outside plant installations, cables shall be rated for installation in outdoor applications where exposed to the elements. Cables shall have waterblock tape and be suitable for direct burial.
- B. UTP Patch Cables:

1. Available with RJ-45 style connectors, coordinate lengths with installation requirements.
 2. Connectors shall be factory installed, with snagless molded strain relief.
 3. Minimum rating Category 6 in accordance with TIA/EIA-568.
 4. Field assembled terminations will not be acceptable.
- C. Voice/Data cable jacketing (entire length) shall be color coded as follows:
1. SCADA – Yellow
 2. Voice/Telephony – Green
 3. Office Network – Blue
- D. Modular jacks shall be color coded as follows:
1. RJ-45 (Data) – Match cable jacket color.
 2. RJ-11 (Voice) – White
- E. Cover plates shall be Office White/ Dusty White (non-metallic).
- F. Acceptable Manufacturers for cover plates and modular jacks: Hubbell, Avaya or approved equal.

2.02 FIBER OPTIC PATCH CABLES

- A. Available with SC or LC style connectors, coordinate with equipment provided. Coordinate lengths with installation requirements.
- B. 125 microns cladding diameter with minimum bending radius of 2 inches or less.
- C. Fiber optic patch cable outer jacket shall be PVC, colored yellow (single mode), orange (multimode) unless otherwise noted.
- D. Connectors shall be colored blue (single mode), beige (multimode) and shall be further color coordinated to identify Tx and Rx.
- E. Manufacturers: Leviton, Panduit; or Engineer approved equal.

2.03 FIBER OPTIC CABLE

- A. Outdoor Fiber Cabling (SCADA):
1. Multiple strand, tight buffer, Single-mode fiber cable. Cable shall be rated for outdoor use. Gel filled buffer tubes are not acceptable.
 2. Optical operating wavelength: Short is 1310nm, long is 1550nm with a maximum tight buffer attenuation of 0.5/0.5 dB/km.
 3. Data transmission rate of 1 Gigabyte per standard compliance of TIA/EIA-568-B.3.
 4. LC or SC style terminations based on equipment requirements.
 5. Fiber cables installed entirely or partially outdoors shall be rated for water blocking protection by means of an Aramid yarn wrap in the outer jacket of the cable.
 6. Minimum Bend Radius:
 - a. Installation: 4.4 inches.
 - b. Operating: 2.9 inches.
 - c. Coordinate bend radius with raceway dimensions, provide appropriate cable or modify raceway as required.
- B. Cable shall have metallic armor for direct buried applications.
- C. Fiber shall have no splices for entire length from source to load.
- D. Acceptable manufacturers: Optical Cable Corporation (OCC), Belden, General Cable Corporation or approved Engineer approved equal. Coordinate with base IT.

2.04 FIBER OPTIC PATCH CONNECTION PANELS

- A. Modular style panels shall have a minimum of six (6) fiber connection points. Unit shall be equipped with an inner drawer which allows for the fiber connectors to be protected on both the incoming and outgoing termination sides. Patch termination shall be compatible with selected fiber terminations (ST/SC/LC).
 - B. Outlet/jack shall be colored blue (single mode), beige (multimode).
 - C. Housing:
 - 1. Rack-mount style patch panels for use with rack mounted equipment.
 - 2. Wall-mounted style, steel, patch panels for use in control panels and other enclosures.
 - D. Each patch point shall have a unique label and directory shall be permanently affixed inside enclosure.
 - E. Acceptable Manufacturers: Seicor, Corning, Commscope, Systimax, or equal.
- 2.05 MANAGED INDUSTRIAL-GRADE ETHERNET SWITCHES
- A. Refer to Specification Section 40 95 10 for switch requirements.
- 2.06 UNMANAGED INDUSTRIAL-GRADE ETHERNET SWITCHES
- A. Refer to Specification Section 40 95 10 for switch requirements.

PART 3 – EXECUTION

3.01 EXAMINATION

- A. Examine areas and conditions under which voice/data systems are to be installed. Notify ENGINEER in writing of conditions detrimental to proper completion of the work. Do not proceed with work until unsatisfactory conditions have been corrected in manner acceptable to the Construction Manager.

3.02 INSTALLATION OF RACEWAY

- A. Provide conduit properly sized for all data and telephone cabling located in spaces where the cabling is surfaced mounted or exposed.
- B. All UTP cables that enter or leave an enclosure and connect to a data jack/wall outlet shall be terminated at a patch panel.
- C. Patch panels shall have 200% spare capacity.
- D. Rack mount patch panels shall utilize horizontal and vertical cable management components.
- E. Network cables and patch cables shall not block or hang in front of equipment or patch panels.
- F. Standalone patch panels shall have hinged mounting brackets.
- G. Provide patch cables for all patch panel points, including spare.

3.03 FIELD QUALITY CONTROL

- A. All UTP cabling shall be installed and tested per the TIA/EIA 568A – Commercial Building Telecommunications Cabling Standard.
- B. Outside entity shall test all fiber optic cabling per the TIA/EIA 568.3 - Optical Fiber Cabling and Components Standard and TIA/EIA 526 – Standard Test Procedures for Fiber Optic Systems and submit report to Engineer. Remove and replace cabling where test results indicate that it does not comply with specified requirements.

Project Name: Born Court Well 1-7
Project Number: 2220555

SECTION 27 20 00
DATA COMMUNICATIONS

END OF SECTION

Project Name: Born Court Well 1-7
Project Number: 2220555

EARTHWORK
DIVISION 31
TABLE OF CONTENTS

SECTION	TITLE
31 23 00	Site Grading, Excavation, and Backfill
31 23 19	Dewatering

PART 1 - GENERAL

1.01 SUMMARY

- A. The work covered by this section consists furnishing all supervision, labor, materials, and equipment necessary for site grading including stripping of topsoil, excavation, trenching and backfilling for utilities, shaping of earth to match proposed grades in the Drawings, and backfilling proposed structures.
- B. Refer to the general specifications provided in Appendix C that are hereby made a part of this contract: “Specifications for Excavating, Trenching, and Backfilling for Utilities”, and “Specifications for Surface Construction”.
- C. Refer to Section 01 57 13 – “Temporary Erosion and Sediment Control” for Soil Erosion and Sedimentation control requirements.

1.02 REGULATIONS AND STANDARDS

- A. All work shall conform to relevant requirements of the State of Michigan Soil Erosion and Sedimentation Part 91, Act 451 of the Public Acts of 1994, as amended.
- B. Compaction: Density of fill material shall be compared to maximum density as determined by the ASTM D-1557 (Modified Proctor Method).
- C. Datum Elevation: Elevations as shown on the site plan and all elevations for the work shall be referenced to NAVD 1988 Datum. The General Contractor shall be held responsible for the correct elevation of the work.

1.03 QUALITY ASSURANCE

- A. The Contractor shall provide compaction testing for fill soils and aggregate. The Contractor shall pay for additional tests if the results show the material to be under the specified percentage of maximum density.

1.04 JOB CONDITIONS

- A. A soil boring has been completed and is shown on the Drawings. Should the Contractor encounter any unusual conditions during excavation operations, he shall advise the Engineer and call for an inspection.
- B. Ground contours have been provided in the Drawings for reference only. Bidders shall be expected to have inspected the Site and satisfied themselves as to actual grades and levels and conditions under which the work is to be performed.
- C. The benchmark provided for elevation reference shall be preserved. If replacement of the benchmark is necessary it will be at the Contractor’s expense.
- D. Utilities: Existing utilities as shown on the Drawings are for reference only. The Contractor shall be responsible for hand digging as necessary to properly locate all existing utilities prior to excavating and shall be responsible for replacement of any damaged utility at no additional cost.

PART 2 - PRODUCTS

- A. Fill: All fill material brought on site and fill placed around structure walls and/or as pipe/trench fill shall be controlled fill meeting requirements of MDOT Class II granular material. The fill shall be

placed in even layers not exceeding nine inches in depth and shall be thoroughly compacted to 95% of maximum density as determined by the Modified Proctor Method.

- B. Aggregate: Aggregate for gravel road/drive area shall be as shown on the Drawings. Aggregate for HMA base shall be as shown on the Drawings.

PART 3 - EXECUTION

3.01 PREPARATION

- A. Topsoil:
1. Remove from all areas of new construction and stockpile on site.
 2. If quantity of stockpiled topsoil is insufficient, provide additional topsoil as required to complete landscape work.
- B. Aggregate Drive/Road:
1. Remove aggregate from all drive/road areas to be disturbed during construction.
- C. Utilities:
1. Before starting excavation establish location and extent of underground utilities occurring in work area.
 2. Notify utility companies to remove and relocate lines which are in conflict with design locations.

3.02 EXCAVATION

- A. Excavate as required for construction of the work. Utilize or dispose of excavated materials as required.
1. Protect excavation and adjacent structures by shoring, bracing, sheet piling or other methods as required.
 2. Remove unsuitable material to firm underlying soils beneath footings, floor slabs, paved areas and walks.
- B. Preparation of Subgrade:
1. Compact granular material under footings, structures, slabs, pavement, and walks to 95% maximum density unless otherwise specified.
- C. Utilities:
1. Comply with requirements of "Specifications for Excavating, Trenching, and Backfilling for Utilities" included in Appendix C.
 2. Maintain, reroute or extend as required, existing utility lines to remain which pass through excavation area.
 3. Protect utility services uncovered by excavation.
 4. Cap off, plug or seal, discontinued utility services and remove from site within excavated areas.

3.03 STABILITY OF EXCAVATIONS

- A. Comply with local codes, ordinances, and requirements of agencies having jurisdiction.
- B. Slope sides of excavations to comply with local codes, ordinances, and requirements of agencies having jurisdiction.
1. Shore and brace where sloping is not possible because of space restrictions or stability of material excavated.
 2. Maintain sides and slopes of excavations in safe condition until completion of backfilling.

- C. Shoring and Bracing:
 - 1. Provide materials for shoring and bracing, such as sheet piling, uprights, stringers, and cross braces, in good serviceable condition as required to carry out the Work.
 - 2. Maintain shoring and bracing in excavations regardless of time period excavations will be open.
 - 3. Extend shoring and bracing as excavation progresses.

3.04 ROUGH GRADING

- A. Rough grade to levels, profiles, contours and elevations required for finished grades and surface treatment.
- B. Maintain the following, rough grades unless otherwise directed by Engineer:
 - 1. Sidewalk: 4 inches below finished grade.
 - 2. Floor Slabs and Exterior Slabs: 6 inches below bottom slab elevation.
 - 3. Pavement Surfaces: As shown.
 - 4. Landscape Areas: 4 inches below finished grades to receive topsoil.

3.05 PLACEMENT AND COMPACTION

- A. Place backfill and fill materials in layers not more than 12 inches in loose depth for material compacted by heavy compaction equipment, and not more than 4 inches in loose depth for material compacted by hand operated tampers.
- B. Under Floor Slabs and Exterior Slabs: MDOT Class II granular material placed in layers maximum 12 inches deep compacted to 95% maximum density.
- C. Under aggregate base for Roadways and Driveway: MDOT Class II granular material placed in layers maximum 12 inches deep compacted to 95% maximum density.
- D. Under Foundations: MDOT Class II granular material placed in layers maximum 12 inches deep compacted to 95% maximum density.
- E. Cast-in-place concrete foundation walls or retaining walls shall not have backfill placed until seven (7) days after completion of walls.
 - 1. Do not operate heavy equipment for spreading or compacting closer to foundation walls or retaining walls than a distance equal to the height of fill or backfill above the top of footing.
 - 2. Bring up backfill as far as practicable evenly on each side of wall and sloped to drain away from the wall.
 - 3. Where fill or backfill is to be placed and compacted against walls, support walls laterally as necessary to prevent damaging or displacing the walls.
 - 4. Replace walls that are damaged or displaced as a result of Contractor's operations at the Contractor's expense.
- F. Surfacing Aggregate and Aggregate Base for hot mix asphalt pavement: MDOT 22A placed in layers not to exceed eight (8) inches compacted to 98% of its maximum unit weight in accordance with MDOT procedures.
- G. Landscaped Areas: Suitable excavated material or granular material placed in layers maximum 12 inches deep compacted to 90% maximum density.
- H. Properly place and compact all required materials and exert proper control over the moisture content of the material and other details necessary to obtain satisfactory results.
 - 1. Remove materials that cannot be compacted with manipulation and/or moisture control.
 - 2. Replace with suitable excavated materials or granular materials at no cost to the Owner.

- I. Correct any deficiencies resulting from insufficient or improper compaction. Retest if required.

3.06 GRADING

- A. Uniformly grade areas within limits of grading under this section, including adjacent transition areas.
- B. Smooth finished surface within specified tolerances, compact with uniform levels or slopes between points where elevations are indicated or between such points and existing grades.
- C. Grading Outside Building Lines:
 - 1. Grade areas adjacent to building lines to drain away from structures and to prevent ponding.
 - 2. Finish surfaces free from irregular surface changes.
- D. Grading Surface of Fill under Building Slabs:
 - 1. Grade smooth and even, free of voids, compacted as specified, and to required elevation.
 - 2. Provide final grades within tolerance of 1/2 inch when tested with 10 foot straightedge.

3.07 SURPLUS MATERIALS

- A. Surplus excavated or unsuitable excavated material becomes the property of the Contractor.
- B. Dispose of surplus or unsuitable excavated materials off site.

3.08 DUST CONTROL

- A. Dust Control Measures:
 - 1. Maintain dust control so as not to cause detriment to the safety, health, welfare, or comfort of any person or cause damage to property or business.
 - 2. Perform at no additional cost to the Owner.

END OF SECTION

PART 1 - GENERAL

1.01 SUMMARY

- A. The work covered by this section consists of furnishing all supervision, labor, materials, and equipment necessary for dewatering excavations required as part of the project.

1.02 JOB CONDITIONS

- A. When dewatering of groundwater is required, the Contractor shall limit the dewatering operation to the minimum time and depth required for construction. The Contractor shall submit to the Engineer and Owner a dewatering plan indicating how dewatering will be accomplished, along with how and where dewatering discharge will be directed and controlled. Dewatering flows shall not be directed immediately to any watercourse. All flow shall be directed to an "ecolobag" or Engineer approved equal sediment trap. The sediment trap shall be located to allow a minimum overland flow 100 feet prior to entering any water course.

PART 2 - PRODUCTS

*** Not Used ***

PART 3 - EXECUTION

- 3.01 See "Specifications for Excavating, Trenching & Backfilling for Utilities" in Appendix C, which are hereby make part of this specification.

END OF SECTION

EXTERIOR IMPROVEMENTS
DIVISION 32
TABLE OF CONTENTS

SECTION	TITLE
32 31 23	Polyvinyl Fences and Gates
32 92 00	Surface Protection and Restoration

PART 1 - GENERAL

1.01 SCOPE

- A. Work includes all labor and materials required to install new polyvinyl fence, (1) double-swing gate with two (2) 4' wide gate leaves per the Contract Drawings.
- B. All materials and work shall be in accordance with Sections 808 and 907 of the Michigan Department of Transportation (MDOT) 2020 Standard Specifications for Construction.

1.02 REFERENCES

- A. Michigan Department of Transportation (MDOT), "2020 Standard Specifications for Construction"
- B. ASTM D 1784 - Standard Specification for Rigid Poly(Vinyl Chloride) (PVC) Compounds and Chlorinated Poly (Vinyl Chloride) (CPVC) Compounds.

1.03 SUBMITTALS

- A. Submit all materials under provisions of Section 01 33 00 – “Submittals.”
- B. Product Data: Manufacturer's data sheets on each product to be used, including:
 - 1. Preparation instructions and recommendations.
 - 2. Storage and handling requirements and recommendations.
 - 3. Installation methods.
- C. Shop Drawings: Submit shop drawings for each product and accessory required. Include information not fully detailed in manufacturer's standard product data.
- D. Selection Samples: For each finish product specified, two complete sets of color chips representing manufacturer's full range of available colors and patterns.
- E. Verification Samples: For each finish product specified, two samples, minimum size 3 inches (76 mm) square, representing actual product, color, and patterns.
- F. Manufacturer's Certificates: Certify products meet or exceed specified requirements.
- G. Closeout Submittals: Provide manufacturer's maintenance instructions that include recommendations for periodic cleaning and maintenance of all components.
- H. Clearly indicate plan layout, spacing of components, accessories, fittings and post anchorage.

1.04 QUALIFICATIONS

- A. Fence and gates shall be obtained from a single source. Materials shall be in accordance with appropriate ASTM standards. Erector shall have a minimum two years of experience installing similar fencing.

1.05 WARRANTY

- A. 30-YEAR Lifetime Limited, Non-Prorated Warranty on Material.

PART 2 - PRODUCTS

2.01 GENERAL

- A. Contractor shall furnish all material including fence panels, posts, rails, braces, concrete anchorage and required appurtenances to complete construction of an eight foot PVC privacy fence
- B. Fence, gates and hardware shall be Superior Privacy Fence system by Digger Specialties, or Engineer approved equal.

2.02 MATERIALS

- A. All materials shall be supplied by the fence manufacturer as part of a complete fence and gates system.
- B. PVC posts shall be heavy wall 5" posts with a minimum 0.150" wall. All line, end, and gate posts shall be installed with aluminum stiffeners as recommended by the fence manufacturer.
- C. Top, mid, and bottom rails shall be 1 3/4" x 5 1/2" PVC. Bottom and mid rails shall contain aluminum stiffeners.
- D. Verticals shall be 7/8" x 11.28" snap lock tongue and groove. Post spacing shall be maximum of 8 feet.
- E. Post caps shall be flat PVC.
- F. Provide and install heavy duty gate hardware.

PART 3 - EXECUTION

- A. General: Installation shall be in accordance with manufacturer's instructions.

END OF SECTION

PART 1 - GENERAL

1.01 DESCRIPTION

- A. This Section includes the work required for protection and restoration of surface features such as site improvements, concrete sidewalks, asphalt pavement, and all trees, shrubs, lawns, and other landscape features as well as installation of new surface improvements.
- B. All areas disturbed by construction operations shall be restored to the original condition thereof or better as determined by the Engineer using information from drawings, surveys, and photographs or video tapes when available.
- C. The work shall be performed in accordance with the specifications and drawings, the MDOT 2020 Standard Specifications for Construction, the “Specifications for Surface Restoration” provided in Appendix C, and the following specifications.

1.02 SUBMITTALS

- A. Submit under provisions of Section 01 33 00 – “Submittals.”
- B. Topsoil Analysis: Certification of suitability by local agricultural agent (USDA), if requested by Owner or Engineer.
- C. Seed Analysis: Certification of purity and germination by manufacturer, if requested by Owner or Engineer.
- D. Trees and Shrubs: Certification by suppliers of source and species, if requested by Owner or Engineer.

1.03 JOB REQUIREMENTS

- A. Areas Disturbed by Construction Operation:
 - 1. Restoration along all utility (water, sewer, forcemain, storm sewer, electrical, etc.) installation including all connection points near buildings and all other areas disturbed during construction.
 - 2. Restoration on site including all areas disturbed during construction.
- B. Scheduling:
 - 1. Restoration of Lawns and Other Surface Features: Promptly following site improvements, and paving.
 - 2. Clean Up: Promptly following restoration.
- C. Seasonal Limitations:
 - 1. Seeding: Spring, summer, and fall with mulching from June 1 to September 1.

PART 2 - PRODUCTS

2.01 MATERIALS

- A. Topsoil, Fertilizer, and Seed: See “Specifications for Surface Restoration”.
- B. Concrete – See Section 03 30 00 – “Cast in Place Concrete.”
- C. HMA – See Appendix C - “Specifications for Surface Restoration”.
- D. Erosion Control Measures: See Appendix C - “Specifications for Surface Restoration”.
- E. Other Site Improvements: Provide materials equal to or better than those that existed prior to start of construction whether shown or not shown on the drawings.

PART 3 - EXECUTION

3.01 PREPARATION

- A. All streets, drives, non-motorized paths, sidewalks, and other improved surfaces disturbed by construction operations shall be replaced to uniform lines and grades established by the Engineer. The finish grade line will be established within three (3) inches of the existing ground profile shown on the drawings unless a proposed grade is shown which indicates otherwise.
- B. The Contractor shall perform all grading, compacting, shaping, and related work required to prepare the subgrade to the satisfaction of the Engineer.

3.02 RESTORATION

Refer to “Specifications for Surface Restoration” as provided in Appendix C.

END OF SECTION

UTILITIES
DIVISION 33
TABLE OF CONTENTS

SECTION	TITLE
33 11 13	Potable Water Supply Wells
	33 11 13 – System Curves
33 14 13	Public Water Utility Distribution Piping

PART 1 - GENERAL

1.01 DESCRIPTION

- A. This Section includes the work required for installing one new vertical turbine pump in an existing well, and appurtenant work.
- B. All work in this Section shall be performed by one of the following prequalified well drilling contractors licensed to drill water wells in the State of Michigan and prequalified by the City of Kalamazoo.
 - 1. Northern Pump and Well, Lansing, Michigan – 517-242-8949
 - 2. Peerless Midwest Inc., Mishawaka, Indiana – 574-254-9050

1.02 RELATED SECTIONS

- A. SECTION 01 33 00 – “Submittals”
- B. SECTION 09 96 00 – “Painting”
- C. SECTION 40 05 13 – “Process Piping”

1.03 REFERENCES

All materials, layout and installations shall meet the requirements of the governing local, state and national codes in effect at the time proposals are received and shall include but not be limited to the following:

- A. AWWA A100-20, “AWWA: Standard for Water Wells”
- B. AWWA E-103-21, “AWWA Standard for Horizontal and Vertical Line-Shaft Pumps”
- C. AWWA C654-21, “AWWA: Standard for Disinfection of Wells”
- D. 1976 P.A. 399, as amended, “Safe Drinking Water Act,” and administrative rules promulgated by the State of Michigan.
- E. 1978 P.A. 368, Part 127, as amended, “Groundwater Quality Control”, and administrative rules promulgated by the State of Michigan.
- F. American Society of Testing Materials (ASTM)
 - 1. A53 – Standard Specification for Pipe, Steel, black and Hot-Dipped Zinc-coated, Welded and Seamless
 - 2. C136 – Standard test Method for Sieve Analysis of fine and Coarse Aggregates
 - 3. C150 – Standard Specification for Portland Cement
- G. NSF/ANSI Standard 61 – AWWA - Drinking Water System Components.
- H. Recommended Standards for Water Works, Great Lakes Upper Mississippi River Board of State Public Health and Environmental Managers (also referred to as Ten States Standards)

1.04 SUBMITTALS

- A. In accordance with Section 01 33 00, submit the following:

1. Dimensional drawings.
 2. Name of manufacturer.
 3. Type and model of pump and motor
 4. Design rotative speed.
 5. Number of stages.
 6. Type of bowl bearings.
 7. Type of lineshaft bearings.
 8. Size of shafting.
 9. Size of pump column.
 10. Size of discharge outlet.
 11. OD of pump bowls.
 12. Data on shop painting.
 13. Total Weight.
 14. Motor Data
 15. Complete certified performance test curves showing capacity versus head, NPSH required, efficiency, and bhp plotted scales consistent with performance requirements.
 16. Dimensional drawings.
- B. Operating, maintenance, and wiring instructions
1. Equipment function, normal operating characteristics, and limiting conditions.
 2. Assembly, installation, alignment, adjustment, and checking instructions.
 3. Operating instructions for startup, routine, and normal operation, regulation and control, shutdown, and emergency conditions.
 4. Lubrication and maintenance instructions.
 5. Guide to troubleshooting.
 6. Parts lists and predicted life of parts subject to wear.
 7. Outline, cross-section, and assembly drawings; engineering data; and wiring diagrams.
 8. Test data and performance curves. Performance curves shall show the minimum continuous stabilized flow for the bowl assemblies.
 9. Installation and operation certificate and a statement from the manufacturer that the equipment is suitable for the intended use.
- C. Water Well and Pump Record as required by the State of Michigan
- D. Completed construction print showing details of construction, depth of pump setting, discharge pipe, lineshaft and bearings, etc.
- E. Certified performance curves based on testing the actual pump being supplied. These curves must be supplied for review prior to shipment of the pumps.
- F. All test data generated as a result of testing in paragraph 3.03 of this section.

1.05 WARRANTY

The manufacturer shall warrant their pumps and motors to be free of defects in material and workmanship for a period of one (1) year after Substantial Completion. Contractor shall submit a written warranty from the manufacturer covering workmanship and materials for the pump and motor. Under terms of the warranty, manufacturer shall furnish and install all replacement parts for any defective component at no cost to the Owner. The provisions of this warranty shall not be construed as relieving or reducing the obligations of the Contractor outlined in elsewhere in this Contract.

PART 2 - PRODUCTS

2.01 GENERAL

Materials shall conform to AWWA A-100-20 "AWWA Standards for Water Wells", and the administrative rules promulgated for "The Safe Drinking Water Act", 1976 P.A. 399, as amended, and 1978 P.A. 368, Part 127, as amended, which are hereby incorporated into these specifications.

Unless otherwise stated herein, the pump and all related components shall in all respects comply with all local and state sanitary and safety regulations.

2.02 WELL CASING

Casing material for casing extension shall be new black steel pipe conforming to ASTM A53 standards. The 12-inch and 20-inch pipe shall have a wall thickness of 0.375 inches. Joints shall be plain end for welding.

2.03 VERTICAL LINESHAFT PUMPS AND MOTORS

A. General

1. One (1) vertical turbine pump and motor shall be provided and installed in the existing well.
2. The pump units shall be product lubricated, surface discharge, deep well turbine pumps, by Floway, Goulds, American-Marsh, or approved equal, for installation the existing well.
3. Minimum Pump Efficiency shall be at least 78%.

B. Performance and Design requirements

1. The following provides requirements for the pump to use as part of the bid. Final pump selection will not be made until after all required well testing and final approval of the capacity of the well by the Michigan Department of Environment, Great Lakes, and Energy (EGLE).
2. For design and rating purposes, the water to be pumped shall be assumed to have a temperature of 55°F.
3. Pump performance shall be stable and free from damaging cavitation, vibration, and noise within the operating head range. The performance of each pump with an enclosed impeller shall be based on a radial running clearance between the bowl wearing ring and the impeller of not less than 6 mils, or 0.5 mil per inch of wearing ring diameter, whichever is greater. The performance of each pump with an open impeller shall be based on a radial running clearance between the bowl and the impeller of not less than 15 mils.
4. At any operating speed, the ratio of rotative speed to the critical speed of a unit or its components shall be less than 0.8 or more than 1.2.

5. See below table for performance and installation data for each pump.

	Well 1-7 (former 2-1)
Design Flow (Gal/min)	800
Design TDH (ft water)	150
Maximum RPM	1800
Minimum Bowl Efficiency	78
Maximum Motor HP	50
Depth of Pump Inlet Setting below top of casing	80
Minimum Discharge Column size (in)	8

The total head does not include losses in the pump discharge head, which must be allowed for by the bidder. The pump curve shall meet the duty point requirement and cross the minimum system curve attached to this specification section.

The design point will be used for any performance evaluation in accordance with the 1U grade standards of the Hydraulic Institute.

C. Pump Discharge Head, Column, Lineshafts

1. The discharge head shall be of close grained, cast iron, ASTM A48 class 30, free of sand holes and other defects, accurately machined with an above surface discharge. The discharge flange shall be machined and drilled to ANSI standards for 125# rating and is to be flat faced.

The top of the discharge head shall be machined to accurately locate a standard NEMA P base driver and have a diameter equal to the driver base diameter (BD). The headshaft shall be coupled to the top lineshaft beneath the motor to facilitate ease of assembly and maintenance. All couplings and other moving or rotating parts shall be covered on all sides by an OSHA approved coupling guard. Coupling guards shall be fabricated from 16 USS gage or thicker galvanized or aluminum-clad steel or from 1/2 inch mesh expanded metal. Each guard shall be designed for easy installation and removal.

All necessary supports and accessories shall be provided for each guard. The pump shall be furnished with an Aluminum nameplate securely mounted to the discharge head. At a minimum it shall contain the following information (design flow, design TDH, HP, RPM, bowl model number, number of stages, manufacturer serial number, pump type & impeller setting dimension).

The discharge head shall have a 1/4" NPT connection for a pressure gauge.

The discharge head shall be painted John Deere Green.

2. The top line-shaft shall be stainless steel ASTM A582, Grade 416 or other similar material. A threaded coupling constructed of the same material as the top line shaft shall be provided to couple the motor shaft to the pump shaft. Impeller adjustment shall be provided by means of a bronze adjusting nut located on top of the motor and constructed of ASTM B16 alloy C36000. After adjustment the nut shall be positively locked in position to the motor clutch.
3. The standard cast iron stuffing box shall be rated for 150 pound discharge pressure and shall be fitted with graphite acrylic packing and have either a greased lantern ring or grease chamber below the first packing ring. The throttle bearing shall be of bronze ASTM B505 alloy 836 or ASTM B505 Alloy C84400. The packing gland shall be of

SECTION 33 11 13
POTABLE WATER SUPPLY WELLS

stainless steel ASTM A743 GR CF-8M with stainless steel studs and with brass or stainless steel adjusting nuts. Sealing between the stuffing box and the discharge head shall be accomplished by means of an "O" ring. Packing box is to be secured in place with a minimum of eight cap screws. The packing box shall utilize a split type packing gland to allow ease of packing removal & installation.

4. The pump bowls shall be cast iron ASTM A48 Class 30. The water passages in the bowls shall be lined with porcelain enamel or fusion epoxy to reduce friction loss, shall be smooth and free from nodules, bumps & dips, shall be free of blow holes, sand holes and other detrimental defects, and shall be accurately machined and fitted. The impellers shall be bronze ASTM B584 and dynamically balanced. Impellers shall be securely fastened to the shaft with stainless steel collets ASTM A582 Grade 416 or taper split bushings of stainless steel. The bearings shall be sleeve type and are to be lubricated by the product being pumped. The bearings are to be located above and below each impeller. The suction bearing shall be permanently packed with food grade grease, and shall have a length not less than 2 times the shaft diameter. The bowls are to be of threaded connection for sizes up to & including 8" diameter, and are to be flanged with machined rabbet fit connections for sizes larger than 8" diameter. Bowl bolting material shall be Type 304 stainless steel (ASTM F593 Gr CS1).
5. The pump shaft shall be A582 grade 416 stainless steel, turned ground and polished. It shall be supported by bronze bearings above and below each impeller. The suction case bearing shall be grease lubricated and protected by a bronze sand collar. The size of the shaft shall be no less than determined by AWWA E103-21.
6. The lineshafts shall be ASTM A582, Grade 416 stainless steel or other similar material ground and polished. Shaft diameter selection shall be based on a combined shear stress of not more than 18% of the ultimate strength or not in excess of 30% of the elastic limit in tension or ANSI/AWWA-E103 specifications and provision that maximum elongation due to hydraulic thrust will no exceed the axial clearance of the impellers in the pump bowls. Intermediate line-shaft section shall be furnished in interchangeable sections not over 10-feet in length.
7. The butting ends of the line-shaft sections shall be machined square to the axis of the shaft and the faces recessed to insure proper contact. The shaft ends shall be threaded form solid steel bars ASTM A108, Grade B1112 or 12L14 and designed with a safety factor 1.5 times the shaft safety factor. Threads shall be left hand to tighten during pump operation.
8. The lineshafts shall be provided with ASTM A269 grade 304 stainless steel sleeves at the location of each lineshaft bearing. Bearing spacing shall not exceed 10' for 1800 rpm. Spacing shall be such that shaft first critical frequency shall be safely above or below the operating frequency.
9. The outer column pipe shall be 8-inch diameter Schedule 60 ASTM A53 grade B steel pipe of ASTM A120 in interchangeable sections not over 10' in length. The weight of the column pipe shall be no less than stated in AWWA E103-21. Top and bottom sections of column pipe shall not exceed 5' in length.

D. Motor Design

The motor shall be a vertical hollow shaft 1800 rpm, three phase, 60 hz, 460 volts with a non-reverse ratchet, P-base, squirrel cage induction design. The motor enclosure shall meet NEMA weather protected Type 1 design with stainless steel screens.

Motor shall have Class F insulation with temperature rise as specified by NEMA standards and shall have a 1.15 service factor. The motor shall at a minimum be rated as NEMA Premium Efficiency and shall be inverter duty rated for use with a variable frequency drive.

Windings shall be copper magnet wire rated at 200° C and moisture resistant. Magnet wire insulation varnish must be of a type designed to resist transient spikes (such as

SECTION 33 11 13
POTABLE WATER SUPPLY WELLS

Inverter Spike Resistant™ ISR), high frequencies, and short time rise pulses produced by inverters. Motor insulation system shall comply with NEMA MG1-1998 Part 31.4.4.2.

Thrust bearing shall be chosen to handle the continuous down thrust as specified by the pump manufacturer with an AFBMA B-10 one-year minimum or 5-year average life under design conditions. Provisions shall be made for momentary up-thrust equal to 30% of rated down-thrust.

2.04 ACCESSORIES

A. Casing Vent

A minimum 2-inch diameter casing vent shall be provided as shown on the drawings. The vent shall be screened, pointed downward and terminate at elevation required in the drawings. The screening shall be not less than 24-mesh per inch and not more than 30-mesh per inch. Screening shall not reduce the vent open area by more than 50%.

B. Air Gauge

An air line gauge shall be provided that is calibrated to read feet of water below the floor elevation. Air piping of 1/4 -inch Type-L copper tubing shall be carried down in the casing to the top of the pump. The tubing shall be attached securely to the pump column in a manner as to prevent the entrance of foreign materials. A suitable air pump shall be provided.

C. Submersible Level Transmitter

Provide and install one Ametek Model 575 NSF61 approved submersible level transmitter in the well and a WTX junction box (Ametek SJB-100, or approved equal), with lightning /surge protectors. A dessicant canister for cable vent tube, shall also be provided for rack mounting at the well. Provide and install one Ametek Model DDMC Digital Meter/Controller for display of level. The transmitter shall transmit a 4-20 mA signal to the local display and to the City of Kalamazoo control system. Level transmitters will be powered by a 12-28 VDC power supply with reverse polarity surge protection located at the MCP panel.

The transmitter diaphragm, housing, and connectors shall be stainless steel. The transmitter shall be supplied with a conduit adapter. Oil fill shall be food grade silicon. The transmitter shall have a range of 0 to 69 feet of water and be supplied with enough cable to set the transducer at 10 feet above the pump and run to the junction box provided, where the cable will be spliced and extended to the MCP by the electrical subcontractor.

The transmitter shall be able to be removed through the top of the discharge head.

PART 3 - EXECUTION

3.01 GENERAL

A. Protection of Quality of Water

1. *Precautions to be Taken:* The Contractor shall take such precautions as are necessary or as may be required permanently to prevent contaminated water or water having undesirable physical or chemical characteristics from entering, through the opening made by the Contractor in drilling any wells, any groundwater. Contractor shall also take all necessary precautions during the construction period to prevent contaminated water, gasoline, or any other contaminant from entering the well, either through the opening or by seepage through the ground surface.

SECTION 33 11 13
POTABLE WATER SUPPLY WELLS

The Contractor shall secure the top of the well casing each night and during all periods when no work is being done on the wells in order to prevent accidents or vandalism. The well shall be furnished with a lockable or tack welded steel plate cover for this purpose.

2. *Corrective Work:* In the event that the well becomes contaminated or that water having undesirable physical or chemical characteristics enters the well because of the neglect of the Contractor, he shall, at his own expense perform such work or supply such casings, seals, sterilizing agents or other material as may be necessary to eliminate the contamination or shut off the undesirable water.

- B. Construction Water: The Contractor must make his own arrangements for obtaining water.
- C. Power and Pumping Equipment: The Contractor is responsible for power needs during pump installation and any temporary pumping equipment needed for testing.

3.02 CASING EXTENSION

- A. The well casing shall be extended as noted on the drawings for protection from flooding.

3.03 FIELD TESTING AND OBSERVATION

- A. General:
 1. Notification: Contractor shall notify Engineer at least 48 hours prior to any testing so that the Engineer may witness the test.
 2. Provide necessary equipment, manpower and assistance.

3.04 PERMANENT PUMP TESTING

- A. General:
 1. Notification: CONTRACTOR shall notify ENGINEER at least 48 hours prior to any testing so that the ENGINEER may witness the test.
 2. Provide necessary equipment, manpower and assistance.
- B. Permanent Pump Performance Testing

An experienced, competent, and authorized representative of the pump manufacturer shall visit the site of the work and inspect, check, adjust if necessary, and approve the equipment installation. The representative shall be present when the equipment is placed in operation, and shall revisit the job site as often as necessary until all trouble is corrected and the equipment installation and operation are satisfactory in the opinion of ENGINEER.

The manufacturer's representative shall furnish a written report certifying that the equipment has been properly installed and lubricated; is in accurate alignment; is free from any undue stress imposed by connecting piping or anchor bolts; and has been operated under full load conditions and that it operated satisfactorily.

All costs of these services shall be included in the contract price for the number of days and round trips to the site as required.

The equipment manufacturer shall furnish a qualified field installation supervisor during the equipment installation. Such services shall be included in the contract price for the number of days and round trips to the site as required.

SECTION 33 11 13
POTABLE WATER SUPPLY WELLS

Manufacturers' installation supervisor shall observe, instruct, guide, and direct the installing contractor's erection or installation procedures. The equipment manufacturer will be provided with written notification 10 days prior to the need for such services.

The installing contractor shall conduct a three step performance test after the new pump is installed.

- A calibrated circular orifice or other approved flow measurement device shall be used, and each step of the test shall have a duration of 30 minutes. The tests shall be conducted at full motor speed and discharge pressure shall be varied to produce 75%, 100% and 125% of the rated gallons per minute capacity.
- The pumping water level, discharge pressure, and flow rate shall be recorded every five minutes during each step.
- All results shall be tabulated, and the results plotted on a performance curve for the pump.
- Test results shall be presented to the Engineer within seven days of the test date, and the pump will not be accepted until the Engineer approves the test results.

All water discharged during testing shall be directed to infiltrate into the ground on City owned property to the southeast. Coordinate with Owner.

The Engineer shall be notified not less than 24 hours before the actual field testing is to be completed.

C. Vibration Testing

On-site vibration testing by an experienced vibration testing technician using approved digital testing equipment shall be performed at the specified pump performance and at shutoff.

- Measure and record vibration levels at the top and bottom of the motor bearings in the axial, vertical and horizontal positions.
- Measure and record vibration at the stuffing box in the axial, vertical and horizontal directions.
- Measure and record vibration at the discharge header in the vertical and horizontal directions.
- Vibration limits in the installed unit shall not exceed 2 mils at the specified operating rotational speed.
- All deficiencies shall be corrected to the Engineer's satisfaction prior to the Owner's acceptance.
- The experience and qualifications of the vibration testing technician and the specific testing equipment to be used shall be approved in writing by the Engineer prior to the testing and the Engineer shall be notified not less than 24 hours before the actual field testing is to be done. After the pumping units have been installed, performance tests shall be conducted. The purpose of these performance tests shall be to demonstrate that the units have been properly installed, and that they and their appurtenant equipment will operate satisfactorily and meet the specified conditions and the guarantees of the CONTRACTOR. For the purpose of these tests, the OWNER will furnish the electricity for the test load when these items are available. The measurement of the quantity of water pumped may or may not be included in the performance test.

3.05 FINAL DISINFECTION

Upon completion of the testing, and with approval of the Owner, the well shall again be disinfected in accordance with AWWA C654-21, "AWWA: Standard for Disinfection of Wells".

The Contractor shall disinfect the well by use of enough chlorine solution to provide a concentration of not less than 50 mg/l of available chlorine in the volume of water contained within the well bore. After the chlorine solution has been in the well for 24 hours, the contractor shall pump water from the well until no

SECTION 33 11 13
POTABLE WATER SUPPLY WELLS

chlorine remains and then collect two bacteriological samples 24 hours apart. The samples shall be delivered to the City of Kalamazoo Water Department for analysis within 8 hours of collection.

The well and pump will be accepted by the OWNER only after verification of satisfactory bacteriological quality of the water. It will be the responsibility of the CONTRACTOR to do such work as necessary, at his expense, to achieve this if the test results are unsatisfactory. Upon completion of the chlorination and sampling, the well may be placed into operation.

Additional disinfection and/or bacteriological testing that will be required if sample results at the well are not satisfactory will be completed at the CONTRACTOR'S expense.

All water discharged during disinfection activities shall be directed to infiltrate into the ground on City owned property to the southeast. Coordinate with Owner.

3.06 ADJUST AND CLEAN

General: Keep pipe and structures clean as work progresses. The Contractor shall completely remove from the sites all rubbish, debris, equipment, and material caused by the performance of the work described in this specification. All disturbed surfaces shall be restored to their condition prior to the start of work or better.

END OF SECTION

**Kalamazoo Born Court
Max and Min System Curve**

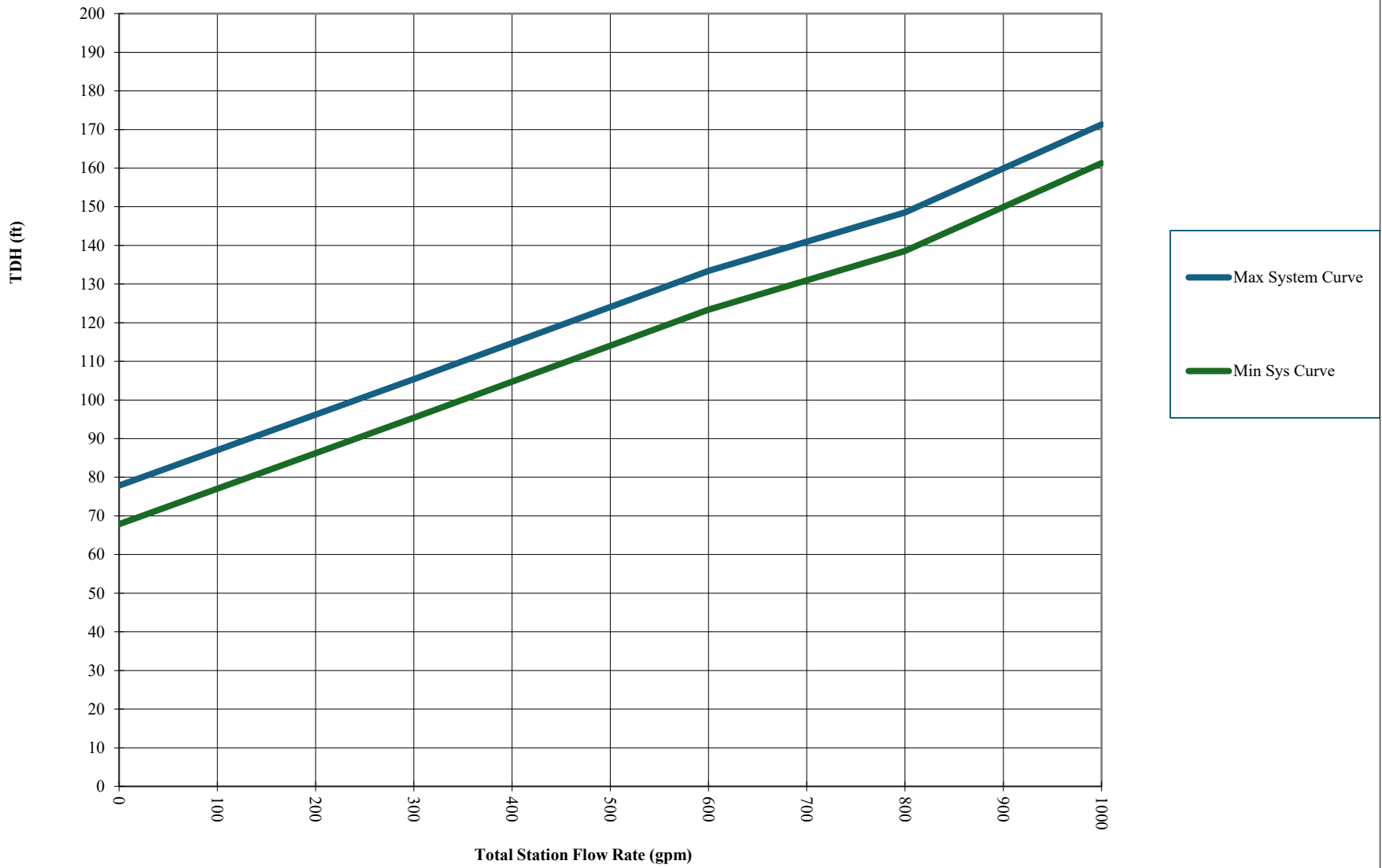

PART 1 - GENERAL

1.01 SUMMARY

- A. The work covered by this section consists furnishing all supervision, labor, materials, and equipment necessary for installation of drinking water site piping, valves, fittings, and accessories below ground.

1.02 RELATED SECTIONS

- A. SECTION 01 33 00 – “Submittals”
- B. Division 31 – Earthwork

1.03 SUBMITTALS

- A. Submit under provisions of Section 01 33 00 – “Submittals.”
- B. Submit data on all pipe, poly-wrap, valves, fittings, and gaskets.

1.04 JOB CONDITIONS

- A. Maintain existing water systems during construction. Limit service interruptions to existing systems to minimum time required for installation of new system.

PART 2 - PRODUCTS

See “Specifications for Water Mains” in Appendix C that are hereby made part of this Specification.

Potable water piping 4-inch diameter and larger shall be ductile iron, meeting requirements of “Specifications for Water Mains” in Appendix C

All buried exterior ductile iron pipe shall be encased in seamless polyethylene sleeve per section 4.02.07 of “Standard Specifications for Watermain” in Appendix C.

PART 3 - EXECUTION

See “Specifications for Water Mains” and “Specifications for Excavating, Trenching, and Backfilling for Utilities” in Appendix C, which are hereby made part of this specification.

END OF SECTION

PROCESS INTEGRATION
DIVISION 40
TABLE OF CONTENTS

<u>SECTION</u>	<u>TITLE</u>
40 05 13	Process Piping
40 05 51	Process Valves
40 91 00	Instrumentation
40 95 10	Process Control Panels
40 95 10.2	Appendix A IO List

PART 1 - GENERAL

1.01 RELATED DOCUMENTS

Drawings and general provisions of the Contract, including the General and Supplementary Conditions and Division 1 Specification Sections apply to this document.

1.02 SUMMARY

- A. The Contractor shall furnish and install all above ground piping as shown on the Drawings complete with all accessories and appurtenances required for the proper performance of the work.
- B. Related Sections
 - 1. SECTION 01 33 00 – “Submittals”
 - 2. SECTION 09 96 00 – “High Performance Coatings”
 - 3. Division 22 – Plumbing
 - 4. SECTION 40 05 51 – “Process Valves”

1.03 REFERENCES

All piping materials, layout, and installation shall meet the requirements of the governing local, state, and national codes and relevant AWWA Standards. Referenced codes and standards shall be the current code or standard in effect at the time proposals are received.

1.04 DESIGN REQUIREMENTS

The Drawings show the general arrangement of the piping. Details of proposed departures due to actual field conditions or other causes shall be submitted to the Engineer for review. The Contractor shall carefully examine the Drawings and shall be responsible for the proper fitting of materials and equipment in each structure as indicated without substantial alteration.

1.05 SUBMITTALS

- A. Submit in accordance with the General and Supplementary Conditions and Section 01 33 00 – “Submittals.”
- B. Submit detailed shop and placement drawings to the Engineer for review for all piping four inches (4”) in diameter or greater.
- C. Manufacturer’s Certificate: Certify that products meet or exceed specified requirements.

1.06 DELIVERY, STORAGE, AND HANDLING

Deliver, store, protect, and handle products as required by the manufacturer.

1.07 WARRANTY

The process piping shall be guaranteed for a period of one year from the date of substantial completion.

PART 2 - PRODUCTS

2.01 MATERIALS

Piping materials and accessories shall conform to the following specifications. Wherever pressure ratings, wall thickness, pipe class, or schedule are given herein, they shall be considered to be the minimum allowed. Piping with a higher rating, classification, or schedule shall be furnished if so called out on the Drawings.

2.02 PIPE, FITTINGS, JOINTS, COATINGS AND LININGS

The Contractor shall furnish and install all piping as shown on the Drawings. All exterior, buried piping shall be as defined in Division 33 of the Project Specifications. Exterior buried piping is defined as the piping below ground to the connection point to the existing raw water main.

All 4" diameter and larger interior or exposed piping shall be as shown on the Drawings. Fittings shall be as shown on the Drawings.

A. Ductile Iron Pipe

All 4-inch and larger water piping shall be ductile iron pipe. Ductile iron pipe shall be AWWA C151 Class 53. Flanged ductile iron pipe shall be in accordance with AWWA C115. All pipe and fittings for water service shall have a cement mortar lining with seal coat conforming to the requirements of AWWA C104 (ANSI A21.4), and ANSI/NSF 61.

For all interior ductile iron and steel flanged pipe, flange connection hardware shall be galvanized or zinc plated carbon steel. Hardware shall comply with the current ASTM A307, Grade B requirements, or approved equal. Bolts and nuts shall comply with the current American Standard for Screw Head ANSI B1.1, Coarse Thread Series, Class 2 fit.

Exteriors of all interior ductile iron pipe and fittings shall have a shop prime coat of paint in accordance with Section 09 96 00 requirements. Ductile iron pipe and fittings that are required to be coated shall be supplied without any exterior asphaltic coating. No asphaltic coating shall be permitted below coatings required by Section 09 96 00.

Flanges and fittings shall be ductile iron and meet AWWA C110/115. Casting and drilling shall be to ANSI B16.1, Class 125. Gaskets shall be Toruseal® gaskets as manufactured by American or equivalent. Gaskets for potable water piping applications shall be SBR rubber per ANSI/AWWA C111/A21.11, certified per NSF 61.

Certified reports of chemical and physical analysis of material must be supplied. Fabrication drawings shall be submitted to the Engineer for approval prior to starting fabrication of any of the material required.

B. SMALL DIAMETER PIPING (3-inch diameter and less) :

1. Pipe and Tube:

- a. Steel pipe shall conform to ASTM designation A-120. Where forming or bending of piping is required, use ASTM -53, Grade B, seamless. Galvanized steel pipe shall be Schedule 40 with screwed joints and fittings. Except at connections to valves, equipment connections shall be made with threaded flanges, unless otherwise specified.
- b. Copper water tube shall be ASTM B-88, Type K underground; Type L above ground. Tube shall be hard drawn seamless copper tubing. Labels shall be provided on all copper piping above ground with maximum 10-foot spacing and a minimum of 3 labels per room. Labels shall be Setmark vinyl labels by Seton

or approved equal. Text for labels shall be as directed by the Owner and Engineer. Provide manufacturer's colors to the Owner for selection.

- c. Brass pipe shall be ANSI/ASTM B-43, IPS 85 red brass.
 - d. Stainless steel pipe shall be used for all instrumentation connections. Stainless steel pipe shall be Schedule 10, Type 316 conforming to ASTM A-312, TP-316.
 - e. Chemical tubing – Polyethylene tubing sized appropriately for the chemical flow rate.
 - f. See Division 22 for additional small diameter pipe specifications.
2. Joints and Fittings
- a. Steel pipe fittings - FS WW-P-521 Class 50 for pipe smaller than 4".
 - b. Copper and brass fittings shall meet ANSI/ASTM B-16.22 pressure fittings.
3. Unions and Couplings
- a. Pipe Size 2" and Under - 150 psi malleable iron for threaded ferrous piping; bronze for copper or brass pipe soldered joints.
 - b. Pipe Size Over 2" - 150 psi forged steel slip-on flanges for ferrous piping; bronze flanges for copper or brass piping.

2.03 PIPE HANGERS AND SUPPORTS

Whether or not specifically shown on the Drawings, Contractor shall support all horizontal runs of pipe to prevent vibration, to maintain proper grading by adjustment, to provide for expansion and contraction and to be neat in appearance. Hangers and supports shall be of standard design whenever possible and best suited to service required.

Saddle stands shall be of an adjustable type bolted to the floor, foundation or concrete base. Install minimum 1" thick grout pad under stand bases. Metal piping supports shall be manufactured by Anvil Intl, Grinnell or Engineer approved equal.

2.04 INSULATION

All outdoor pipe, fittings, and valves shall be insulated. Pipe insulation shall be 2-inch thick ArmaFlex closed cell, fiber free elastomeric foam with UV resistant PVC jacket with silicone sealing at seams and joints.

2.05 JOINTS AND ACCESSORIES

A. Flange Adapters

Flange adapters for ductile iron pipe shall be furnished where specifically shown on the Drawings and shall adapt plain end pipe to a standard ANSI B16.1, Class 125 flange compatible with AWWA C110.

Flange adapters shall be EBAA Iron Series 2100 Megaflange, or Engineer approved equal. Gaskets shall be suitable for potable water service with NSF 61 certification. Hardware shall be zinc coated steel. Couplings for ductile iron pipe shall be coated in accordance with the specification for the pipe on which they are used.

B. Pipe taps

Pipe taps shall be as shown in the locations and the sizes indicated on the Drawings. All taps will be temporarily plugged at the point of fabrication. Tapping method and thread shall meet the requirements of the pipe manufacturer and shall be rated for the pressure of the pipe.

C. Sample Ports

Sample ports shall be provided as indicated on the Drawings. Sample ports shall consist of a 3/8" diameter tap, 3/8" diameter ball valve, and 3/8" diameter copper tubing gooseneck. Sample port shall be smooth nosed with no threaded fittings.

D. Pressure Gauges for Water

Pressure gauges shall be provided as shown on the Drawings. Gauges shall be liquid filled and provided with 3 1/2" dial. A snubber assembly shall be provided with each gauge to dampen pressure pulsations. Provide diaphragm with stainless steel housing and diaphragm material suitable for potable water. Range shall be as shown on the Drawings. Gauges shall be Type 1009SW Duralife pressure gages for severe service as manufactured by Ashcroft or Engineer approved equal. Wetted materials shall be NSF 61 certified compatible with potable water as recommended by manufacturer.

PART 3 - EXECUTION

3.01 GENERAL

All pipe and fittings delivered to the Project shall be accompanied by certification papers showing that the pipe and fittings meet the applicable specifications.

All exposed piping shall be run straight and square with the structure in a neat and workmanlike manner and shall be coordinated with other work. Run piping true to line and grade.

Piping shall be hung from the building structure or laid in the ground in a manner that will allow expansion and maintain alignment.

Pipe taps for ductile iron pipe shall conform to ANSI A21.51. Steel pipe taps shall be welded half-couplings or saddle type and shall be attached in the shop.

The Contractor shall provide the necessary material and labor to make connections to existing piping when called for on the Drawings. All necessary gaskets, bolts and fittings shall be provided for this purpose.

Pipe shall be kept clean. During construction, openings in pipe shall be fitted with temporary plugs except where the pipe is actually being worked on. Piping must be clean at time of final acceptance of the work.

When piping is to connect to a piece of equipment it shall be run symmetrically, and it shall terminate so as to properly fit the fixture or piece of equipment in accordance with the fixture or Equipment Manufacturer's rough-in sheets or shop drawings.

3.02 HYDROSTATIC TEST

A. Procedure

All pressure pipe shall be tested to a pressure of 150 psig. All tests will be made by the Contractor using his own equipment, operators, and supervision, in the presence of the Engineer or his duly authorized representative. The length of the section to be tested shall be as approved by the Engineer, or as shown on the Drawings. The test shall not be against an existing valve, unless written permission is obtained from the water system operator. In no case shall a test be made against an existing valve that is found to be leaking or otherwise defective.

B. Air Removal Before Test

Before applying the specified test pressure, all air shall be expelled from the pipe. If permanent air vents are not located at all high points, the Contractor shall install corporation cocks at such points so the air can be expelled as the line is filled with water. After all the air has been expelled, the corporation cocks shall be closed and the test pressure applied.

C. Leakage Test

A leakage test shall be conducted in the presence of the Engineer after the pressure test has been satisfactorily completed. The Contractor shall furnish the pump, pipe, connections, gages and all other necessary apparatus, and shall furnish the necessary assistance to conduct the test. The duration of the test shall be 1 hour.

No leakage shall be allowed.

The Owner shall be furnished a written report of the results of the leakage test that identifies the specific length of pipe tested, the pressure, the duration of the test, and the amount of leakage. The report shall be signed by the Contractor and the Engineer.

D. Variation from Permissible Leakage

If any test of pipe discloses leakage, the Contractor shall at his own expense locate and repair the leaks.

E. Time for Making Test

The pipe may be subject to hydrostatic pressure and inspected and tested for leakage at any convenient time after all supports and restraints have been completed.

END OF SECTION

PART 1 - GENERAL

1.01 RELATED DOCUMENTS

Drawings and general provisions of the Contract, including the General and Supplementary Conditions and Division 1 Specification Sections apply to this document.

1.02 SUMMARY

- A. The Contractor shall furnish and install all above ground piping as shown on the Drawings complete with all accessories and appurtenances required for the proper performance of the work.
- B. Related Sections
 - 1. SECTION 01 33 00 – “Submittals”
 - 2. SECTION 09 96 00 – “High Performance Coatings”
 - 3. Division 22 – Plumbing
 - 4. SECTION 40 05 51 – “Process Valves”

1.03 REFERENCES

All piping materials, layout, and installation shall meet the requirements of the governing local, state, and national codes and relevant AWWA Standards. Referenced codes and standards shall be the current code or standard in effect at the time proposals are received.

1.04 DESIGN REQUIREMENTS

The Drawings show the general arrangement of the piping. Details of proposed departures due to actual field conditions or other causes shall be submitted to the Engineer for review. The Contractor shall carefully examine the Drawings and shall be responsible for the proper fitting of materials and equipment in each structure as indicated without substantial alteration.

1.05 SUBMITTALS

- A. Submit in accordance with the General and Supplementary Conditions and Section 01 33 00 – “Submittals.”
- B. Submit detailed shop and placement drawings to the Engineer for review for all piping four inches (4") in diameter or greater.
- C. Manufacturer’s Certificate: Certify that products meet or exceed specified requirements.

1.06 DELIVERY, STORAGE, AND HANDLING

Deliver, store, protect, and handle products as required by the manufacturer.

1.07 WARRANTY

The process piping shall be guaranteed for a period of one year from the date of substantial completion.

PART 2 - PRODUCTS

2.01 MATERIALS

Piping materials and accessories shall conform to the following specifications. Wherever pressure ratings, wall thickness, pipe class, or schedule are given herein, they shall be considered to be the minimum allowed. Piping with a higher rating, classification, or schedule shall be furnished if so called out on the Drawings.

2.02 PIPE, FITTINGS, JOINTS, COATINGS AND LININGS

The Contractor shall furnish and install all piping as shown on the Drawings. All exterior, buried piping shall be as defined in Division 33 of the Project Specifications. Exterior buried piping is defined as the piping below ground to the connection point to the existing raw water main.

All 4" diameter and larger interior or exposed piping shall be as shown on the Drawings. Fittings shall be as shown on the Drawings.

A. Ductile Iron Pipe

All 4-inch and larger water piping shall be ductile iron pipe. Ductile iron pipe shall be AWWA C151 Class 53. Flanged ductile iron pipe shall be in accordance with AWWA C115. All pipe and fittings for water service shall have a cement mortar lining with seal coat conforming to the requirements of AWWA C104 (ANSI A21.4), and ANSI/NSF 61.

For all interior ductile iron and steel flanged pipe, flange connection hardware shall be galvanized or zinc plated carbon steel. Hardware shall comply with the current ASTM A307, Grade B requirements, or approved equal. Bolts and nuts shall comply with the current American Standard for Screw Head ANSI B1.1, Coarse Thread Series, Class 2 fit.

Exteriors of all interior ductile iron pipe and fittings shall have a shop prime coat of paint in accordance with Section 09 96 00 requirements. Ductile iron pipe and fittings that are required to be coated shall be supplied without any exterior asphaltic coating. No asphaltic coating shall be permitted below coatings required by Section 09 96 00.

Flanges and fittings shall be ductile iron and meet AWWA C110/115. Casting and drilling shall be to ANSI B16.1, Class 125. Gaskets shall be Toruseal® gaskets as manufactured by American or equivalent. Gaskets for potable water piping applications shall be SBR rubber per ANSI/AWWA C111/A21.11, certified per NSF 61.

Certified reports of chemical and physical analysis of material must be supplied. Fabrication drawings shall be submitted to the Engineer for approval prior to starting fabrication of any of the material required.

B. SMALL DIAMETER PIPING (3-inch diameter and less) :

1. Pipe and Tube:

- a. Steel pipe shall conform to ASTM designation A-120. Where forming or bending of piping is required, use ASTM -53, Grade B, seamless. Galvanized steel pipe shall be Schedule 40 with screwed joints and fittings. Except at connections to valves, equipment connections shall be made with threaded flanges, unless otherwise specified.
- b. Copper water tube shall be ASTM B-88, Type K underground; Type L above ground. Tube shall be hard drawn seamless copper tubing. Labels shall be provided on all copper piping above ground with maximum 10-foot spacing and a minimum of 3 labels per room. Labels shall be Setmark vinyl labels by Seton

or approved equal. Text for labels shall be as directed by the Owner and Engineer. Provide manufacturer's colors to the Owner for selection.

- c. Brass pipe shall be ANSI/ASTM B-43, IPS 85 red brass.
 - d. Stainless steel pipe shall be used for all instrumentation connections. Stainless steel pipe shall be Schedule 10, Type 316 conforming to ASTM A-312, TP-316.
 - e. Chemical tubing – Polyethylene tubing sized appropriately for the chemical flow rate.
 - f. See Division 22 for additional small diameter pipe specifications.
2. Joints and Fittings
- a. Steel pipe fittings - FS WW-P-521 Class 50 for pipe smaller than 4".
 - b. Copper and brass fittings shall meet ANSI/ASTM B-16.22 pressure fittings.
3. Unions and Couplings
- a. Pipe Size 2" and Under - 150 psi malleable iron for threaded ferrous piping; bronze for copper or brass pipe soldered joints.
 - b. Pipe Size Over 2" - 150 psi forged steel slip-on flanges for ferrous piping; bronze flanges for copper or brass piping.

2.03 PIPE HANGERS AND SUPPORTS

Whether or not specifically shown on the Drawings, Contractor shall support all horizontal runs of pipe to prevent vibration, to maintain proper grading by adjustment, to provide for expansion and contraction and to be neat in appearance. Hangers and supports shall be of standard design whenever possible and best suited to service required.

Saddle stands shall be of an adjustable type bolted to the floor, foundation or concrete base. Install minimum 1" thick grout pad under stand bases. Metal piping supports shall be manufactured by Anvil Intl, Grinnell or Engineer approved equal.

2.04 INSULATION

All outdoor pipe, fittings, and valves shall be insulated. Pipe insulation shall be 2-inch thick ArmaFlex closed cell, fiber free elastomeric foam with UV resistant PVC jacket with silicone sealing at seams and joints.

2.05 JOINTS AND ACCESSORIES

A. Flange Adapters

Flange adapters for ductile iron pipe shall be furnished where specifically shown on the Drawings and shall adapt plain end pipe to a standard ANSI B16.1, Class 125 flange compatible with AWWA C110.

Flange adapters shall be EBAA Iron Series 2100 Megaflange, or Engineer approved equal. Gaskets shall be suitable for potable water service with NSF 61 certification. Hardware shall be zinc coated steel. Couplings for ductile iron pipe shall be coated in accordance with the specification for the pipe on which they are used.

B. Pipe taps

Pipe taps shall be as shown in the locations and the sizes indicated on the Drawings. All taps will be temporarily plugged at the point of fabrication. Tapping method and thread shall meet the requirements of the pipe manufacturer and shall be rated for the pressure of the pipe.

C. Sample Ports

Sample ports shall be provided as indicated on the Drawings. Sample ports shall consist of a 3/8" diameter tap, 3/8" diameter ball valve, and 3/8" diameter copper tubing gooseneck. Sample port shall be smooth nosed with no threaded fittings.

D. Pressure Gauges for Water

Pressure gauges shall be provided as shown on the Drawings. Gauges shall be liquid filled and provided with 3½" dial. A snubber assembly shall be provided with each gauge to dampen pressure pulsations. Provide diaphragm with stainless steel housing and diaphragm material suitable for potable water. Range shall be as shown on the Drawings. Gauges shall be Type 1009SW Duralife pressure gages for severe service as manufactured by Ashcroft or Engineer approved equal. Wetted materials shall be NSF 61 certified compatible with potable water as recommended by manufacturer.

PART 3 - EXECUTION

3.01 GENERAL

All pipe and fittings delivered to the Project shall be accompanied by certification papers showing that the pipe and fittings meet the applicable specifications.

All exposed piping shall be run straight and square with the structure in a neat and workmanlike manner and shall be coordinated with other work. Run piping true to line and grade.

Piping shall be hung from the building structure or laid in the ground in a manner that will allow expansion and maintain alignment.

Pipe taps for ductile iron pipe shall conform to ANSI A21.51. Steel pipe taps shall be welded half-couplings or saddle type and shall be attached in the shop.

The Contractor shall provide the necessary material and labor to make connections to existing piping when called for on the Drawings. All necessary gaskets, bolts and fittings shall be provided for this purpose.

Pipe shall be kept clean. During construction, openings in pipe shall be fitted with temporary plugs except where the pipe is actually being worked on. Piping must be clean at time of final acceptance of the work.

When piping is to connect to a piece of equipment it shall be run symmetrically, and it shall terminate so as to properly fit the fixture or piece of equipment in accordance with the fixture or Equipment Manufacturer's rough-in sheets or shop drawings.

3.02 HYDROSTATIC TEST

A. Procedure

All pressure pipe shall be tested to a pressure of 150 psig. All tests will be made by the Contractor using his own equipment, operators, and supervision, in the presence of the Engineer or his duly authorized representative. The length of the section to be tested shall be as approved by the Engineer, or as shown on the Drawings. The test shall not be against an existing valve, unless written permission is obtained from the water system operator. In no case shall a test be made against an existing valve that is found to be leaking or otherwise defective.

B. Air Removal Before Test

Before applying the specified test pressure, all air shall be expelled from the pipe. If permanent air vents are not located at all high points, the Contractor shall install corporation cocks at such points so the air can be expelled as the line is filled with water. After all the air has been expelled, the corporation cocks shall be closed and the test pressure applied.

C. Leakage Test

A leakage test shall be conducted in the presence of the Engineer after the pressure test has been satisfactorily completed. The Contractor shall furnish the pump, pipe, connections, gages and all other necessary apparatus, and shall furnish the necessary assistance to conduct the test. The duration of the test shall be 1 hour.

No leakage shall be allowed.

The Owner shall be furnished a written report of the results of the leakage test that identifies the specific length of pipe tested, the pressure, the duration of the test, and the amount of leakage. The report shall be signed by the Contractor and the Engineer.

D. Variation from Permissible Leakage

If any test of pipe discloses leakage, the Contractor shall at his own expense locate and repair the leaks.

E. Time for Making Test

The pipe may be subject to hydrostatic pressure and inspected and tested for leakage at any convenient time after all supports and restraints have been completed.

END OF SECTION

PART 1 - GENERAL

1.01 RELATED DOCUMENTS

Drawings and general provisions of the Contract, including the General and Supplementary Conditions and Division 1 Specification Sections apply to this document.

1.02 SUMMARY

- A. Work included in this section includes furnishing and installing process valves as shown on the Drawings complete with all accessories and appurtenances required for the proper performance of the work.
- B. The Drawings indicate the general location of the valves and the intended service, type, and valve size. The Contractor shall be responsible for furnishing all valves to provide a complete, ready-to-operate facility.
- C. Related Sections:
 - 1. SECTION 01 33 00 – “Submittals”
 - 2. SECTION 40 05 13 – “Process Piping”

1.03 REFERENCES

All valve materials and installation shall meet the requirements of the governing local, state, and national codes. Referenced codes and standards shall be the current code or standard in effect at the time proposals are received.

1.04 DELIVERY, STORAGE, AND HANDLING

- A. Prepare valves for shipping to protect internal parts against rust and corrosion, and to protect threads, flange faces, grooves, and weld ends. Set globe valves closed to prevent rattling. Set ball and plug valves open to minimize exposure of functional surfaces. Set butterfly valves closed or slightly open, and block check valves in either open or closed position.
- B. Maintain valve end protection during storage. Store indoors and maintain valve temperature higher than ambient dew-point temperatures. If outdoor storage is necessary, store valves off the ground in watertight enclosures.
- C. Use a sling to handle large valves. Rig to avoid damaged parts. Do not use handwheels and stems as lifting or rigging point.

1.05 SUBMITTALS

- A. Submit in accordance with Section 01 33 00 – “Submittals.”
- B. Submit detailed shop and placement drawings to the Engineer for review for all valves including detailed drawings, material lists, and installation, operation, and maintenance instructions on all equipment furnished under this section.
- C. Manufacturer’s Certificate: Certify that products meet or exceed specified requirements.

1.06 WARRANTY

The process valves shall be guaranteed for a minimum period of one year from the date of substantial completion.

PART 2 - PRODUCTS

2.01 MATERIALS:

Materials used in the production of valves shall be of the best quality used in normal industrial practice for the service intended. Material shall be free of all defects and imperfections that could affect the serviceability of the product. The materials and types of valve construction specified below are for potable water service.

Valves shall be the standard product of a manufacturer regularly engaged in the production of equipment of this nature.

2.02 EQUIPMENT:

A. Resilient Wedge Gate Valves:

Gate valves for above ground service shall meet AWWA C515 with a 250 psig working pressure. Valves shall be certified to NSF/ANSI 61 and 372. Joints shall be flanged per ASME B16.1, Class 125 and AWWA C110. Fusion-bonded epoxy shall be in accordance with AWWA C550. Valves shall be provided with a handwheel.

Valves shall be American Flow Control, or Engineer approved equal. Valves shall open right/clockwise.

B. Globe Style Silent Check Valves

The check valve shall be of the silent operating type that begins to close as the forward flow diminishes and fully closes at zero velocity preventing flow reversal and resultant water hammer. Valve shall be suitable for vertical installation as shown in the drawings, and shall be able to seal at a pressure of approximately 10 psi across the valve.

The valve shall be certified to NSF/ANSI 61, Drinking Water System Components – Health Effects, and certified to be Lead-Free in accordance with NSF/ANSI 372.

Globe style valve shall be provided in 12-inch size and have flat faced flanges in accordance with ASME B16.1 for Class 125 iron flanges.

The valve design shall incorporate a center guided, spring loaded disc and having a short linear stroke that generates a flow area equal to the nominal valve size. The operation of the valve shall not be affected by the position of installation. The valve shall be capable of operating in the horizontal or vertical positions with the flow up or down. All component parts shall be field replaceable without the need of special tools. Globe style valves shall be provided with a replaceable guide bushing held in position by the spring. The spring shall be designed to withstand 100,000 cycles without failure and provide a cracking pressure of 0.5 psi. The globe disc shall be concave to the flow direction providing for disc stabilization, maximum strength, and a minimum flow velocity to open the valve. The valve disc and seat shall have a seating surface finish of 16 micro-inch or better to ensure positive seating at all pressures. The leakage rate shall not exceed the allowable rate for metal seated valves allowed by AWWA Standard C508 or 1 oz per hour per inch of valve diameter. Globe style valve seats shall be contained with a machined counterbore and restrained by the mating flange and gasket.

Valve bodies shall be constructed of ASTM A126 Class B cast iron for Class 125 valves. Seat and disc shall be ASTM B584 Alloy C87600 lead-free bronze. Compression spring shall be ASTM A313 Type 316 stainless steel with ground ends.

Valve interiors and exteriors shall be coated with an NSF/ANSI 61 certified fusion bonded epoxy in accordance with AWWA C550.

The valves shall be hydrostatically tested at 1.5 times their rated cold working pressure and seat tested at the valve CWP. Manufacturer shall provide test certificates, dimensional drawings, parts list drawings, and operation and maintenance manuals. Contractor shall use Series 1800 globe style silent check valves as manufactured Val-Matic Corporation, Elmhurst, IL USA as base bid.

C. Air Release Valves

Well Service Combination Air Release and Vacuum Breaker Valve shall be Cla-Val Series 33AWS Well Service Combination Valve, as base bid. Valve shall be installed in the vertical position on top of the pipeline. Air release valve shall be a normally open, automatic float-operated valve, designed to protect pipelines and vertical turbine pump applications from air lock and vacuum collapse.

A Throttling Device shall be factory installed onto the exhaust port of the Combination Air Release and Vacuum Breaker Valve. Throttling Device shall allow free flow of air in and out of the valve; close upon rapid air exhaust and be adjustable to control the rate of air being exhausted; to reduce pressure surges.

Materials and characteristics for the Air Release and Vacuum Breaker Valve shall be as follows:

<u>Component</u>	<u>Material/Characteristic</u>
Body, Cover, Throttling Device	Ductile Iron – ASTM A536
Float Ball Assembly	Stainless Steel
Internal Trim Parts	Stainless Steel and Delrin
Seals and O-Rings	NBR
Hardware	Steel, Cadmium Plated
Inlet Connection	2" Female Threaded NPT
Operating Pressure Rating	300psi
Temperature Rating	Water to 180°F
Wetted Metallic Parts	Stainless Steel
Interior & Exterior Coating	Fusion Bonded Epoxy – ANSI/NSF 61 Approved

1. Connections

Inlet Connections for Air and Vacuum Release Valves shall be 2-inch female NPT threaded connection. Outlet connection shall be female NPT connection.

2. Valve Body

Valve body shall be a single one piece design. Body shall have a ¼" NPT drain connection with pipe plug installed. No fabrication or welding shall be used in the manufacturing process of the valve body. Access to the internal float ball assembly, for necessary servicing, cleaning and repairing shall be possible without removing the air release valve from the pipeline.

3. Valve Cover and Seat Assembly

Valve seat assembly shall be fastened onto the cover. Seat assembly shall be easily removable from the cover, for any necessary servicing or cleaning.

4. Factory Testing

Each Well Service Combination Air Release and Vacuum Breaker Valve shall be factory Tested in accordance with ISO 9001: 2008. The integral stainless steel float ball only shall be hydrostatically pressure tested to 275 PSI. There shall be no internal leakage. Float ball test shall be applied for a minimum of 3 minutes.

The standard factory test for the air release valve assembly shall include a low-pressure seat leak test and a high pressure body and seat leak test. Pressure in test manifold is raised to 1-1/2 - 2 PSI for the low pressure seat leak test and 90 PSI for the high-pressure seat and body leak test. No visible leakage is permitted through the air release valve seat, the pressure boundary walls of the valve body, valve cover or the valve body-cover joint. All leaking valves shall be rejected.

2.01 ACCESSORIES

- A. Valves shall be equipped with accessories as noted or as required for a workable, complete installation. Operating wrenches, levers, extension stems, guides, floor boxes, or valve boxes shall be furnished and installed. Operators shall be installed, adjusted, and tested for operation by the valve manufacturer.
- B. Valve Tags. All process valves shall be provided with a valve tag. The tag shall indicate the valve number as provided on the schedule. The tag shall be fabricated of stainless steel with the letters etched clearly on it. The tag shall be attached to the valve with a metal cable/chain.

PART 3 - EXECUTION

3.01 EXAMINATION

Examine piping system for compliance with requirements for installation tolerances and other conditions affecting performance of valves. Do not proceed with installation until unsatisfactory conditions have been corrected.

- A. Examine valve interior for cleanliness, freedom from foreign material, and corrosion. Remove special packing materials.
- B. Operate valve from fully open to fully closed positions. Examine guides and seats made accessible by valve operation.
- C. Examine mating flange faces for conditions that might cause leakage. Check bolting for proper size, length, and material. Check gasket material for proper size, material composition, and freedom from defects or damage.
- D. Do not attempt to repair defective valves. Replace with new valves.

3.02 INSTALLATION & RESTRAINT

Install valves as indicated, according to manufacturer's written instructions. Install valves with unions or flanges at each piece of equipment arranged to allow servicing, maintenance, and equipment removal without system shutdown.

3.03 INSPECTION AND TESTS

All valves shall be tested along with the process pipe in accordance with Section 40 05 13 – “Process Piping.”
All valves with surface and visible defects shall be removed and replaced with new valves prior to final acceptance. All valves shall be operated by the Contractor in the presence of the Engineer.

END OF SECTION

PART 1 - GENERAL

1.01 RELATED DOCUMENTS

- A. Drawings and general provisions of the contract, including General and Supplementary Conditions and Division 01 specification sections, apply to this section. If differing requirements are identified elsewhere (in these specifications or on drawings or separate instructions), the more stringent requirement shall be met.

1.02 DESCRIPTION

- A. The work of this section includes furnishing and installing all electrical (process) instrumentation, for system operation.

1.03 RELATED SECTIONS

- A. Division 26 - Electrical

1.04 REFERENCES

- A. Applicable Standards and Codes:
 1. American National Standards Institute (ANSI).
 2. American Society for Testing & Materials (ASTM).
 3. Institute of Electrical & Electronic Engineers (IEEE).
 4. Instrument Society of America (ISA).
 5. National Electrical Code (NEC).
 6. National Electrical Contractors "Standard of Installation" (NECA).
 7. National Electrical Manufacturers Association (NEMA).
 8. National Board of Fire Underwriters (NBFU).
 9. National Fire Protection Association (NFPA).
 10. Underwriters Laboratories, Inc. (UL).

1.05 SUBMITTALS

- A. Submit under provisions of Division 1 - Submittals.
- B. Provide shop drawings and product data (for all items) approval (data is) required for:
 1. Level Transmitters (LE/LIT)
 2. Temperature Transmitter (TE/TT)
 3. Flow Meters (FE/FIT)
 4. Pressure Transmitter (PE/PT)
 5. Other miscellaneous accessories devices.
- C. At project substantial completion, per Division 1, provide operation and maintenance manuals bound in a spiral hard cover binder containing detailed record drawings as provided above and renewal parts information including source location and maintenance recommendations.

1.06 SPECIAL WARRANTY

- A. Do not use any required spare equipment furnished under specification for guarantee work during the warranty period.

1.07 DELIVERY, STORAGE AND HANDLING

- A. All instrumentation equipment shall be stored and protected from dampness and humidity during construction.

1.08 MAINTENANCE

- A. Touch up or refinish damaged paint.

PART 2 - PRODUCTS

2.01 ELECTROMAGNETIC FLOW METERS

- A. New flow meter sensor and remote transmitter will be furnished, installed, calibrated, and configured by the Contractor.
- B. New 8" flow meter (FE/FIT) shall be installed as indicated on the plans in the meter chamber. Flow meter shall indicate and totalize effluent flow. Flow indication shall be in gallons per minute with totalized flow units of million gallons. Totalized flow shall be displayed at the transmitter. Normal operation will be between 150 and 3,000 gallons per minute with an operation range of 6 to 6,100 gallons per minute.
- C. Electromagnetic flow meters shall conform to the following Specification unless otherwise noted:
 1. Flow meters shall be constructed with the flow transmitter remotely mounted.
 2. Flow meter Size: The meter flow tube size shall conform to the line size as noted in B above.
 3. Flow tube sensors shall be Hasteloy C, bullet-nose (pointed) style electrode with stainless steel ground rings upstream and downstream. Grounding electrodes are not acceptable.
 4. Flow tube shall be stainless steel. Process connection shall be carbon steel raised flanges rated for ANSI Class 150 with a PTFE/Teflon liner. Verify piping drawings to confirm connection type. Flow sensor housing shall have protection rating to meet IP67 continuous submergence standard.
 5. Output: A programmable flow meter shall convert the flow signal of the primary element into an appropriate linear 4-20mA signal. The output shall be isolated linear and be capable of driving 0-750 ohms. The electronics shall employ an onboard self-diagnostics package. Hart Protocol compatible.
 6. Relay Contact Scaled Pulse Output: Provide dry contact scaled pulse output option. Relay contact: Max. 28V, max. 250mA, max. 3w.
 7. Unit shall have nonvolatile memory integral with transmitter to save calibration settings and other information necessary to properly operate.
 8. Sampling frequency up to 100 Hz with inherent levels of noise.
 9. Empty pipe detection.
 10. Reverse flow detection with discrete output to indicate reverse flow through the pipe.
 11. Adjustments: The field adjustments required shall be zero and span, and they shall be adjustable without the use of special test equipment. These adjustments shall allow adjustment of signal damping and low flow cutoff to calibrate the equipment.
 12. High Accuracy Performance: The electronics shall employ all digital electronics to ensure an accuracy of measurement of $\pm 0.2\%$ of rate 1.0 to 30 feet per second. This accuracy capability will range from $\pm 0.1\%$ to full scale of flow rate. Adjustable flow range shall meet or exceed 75:1 turndown.
 13. Unit Enclosure Rating: Unit shall be rated to meet IP68 continuous submersion under pressure standard.
 14. Grounding: Provide compatible grounding rings and connections to properly ground the flow tube per manufactures specifications.
 15. Transmitter Enclosure Rating: Die-cast aluminum transmitter enclosure shall be rated NEMA 4.

16. Two-line Integral illuminated digital flow display capable of displaying flow rate and totalized flow simultaneously. Meter shall be capable of Bi-directional flow with contact outputs as forward or reverse indication.
17. Meter shall operate on a 120VAC (60 hz) power source nominally.
18. Total meter construction shall comply with ISO 9000 Standards and be FM approved. A computer printout of actual hydraulic calibration traceable to NIST Standards shall be provided.
19. Transmitter shall be interchangeable without effect of meter accuracy or the need for recalibration for all meter sizes.
20. Provide with Smart Meter Verification option.
21. Provide required lengths of Manufacturer's cable for remote mounted indicators.
22. Manufacturers: Base bid Rosemount 8750W with Remote Wall-Mounted Transmitter or Engineer approved equal by Endress+Hauser.
23. Provide NSF certification for use with municipal water systems.
24. Provide a two-year warranty as standard.

2.02 PRESSURE INDICATING TRANSMITTERS (PE/PT)

- A. Transmitter units (a pressure transmitter with the associated sensing element) supplied under this Contract shall conform to the following Specification unless otherwise noted.
- B. Operating Range:
 1. (Station Discharge Pressure) : 0 - 150 psi
- C. Sensor and Transmitter Performance:
 1. Accuracy: The electronics shall employ all digital microprocessor based electronics to insure an accuracy of measurement of 1.5% of span or less.
 2. This accuracy capability will range from 10% to 100% of pressure.
 3. Stability: less than 0.25% of URL, per year for 5 years.
- D. Pressure Sensor:
 1. Material:
 - a. AISI 316L Stainless steel wetted parts and diaphragm.
 - b. Housing: Aluminum
 - c. Teflon O-rings.
 - d. Silicone fill fluid, or as required for approval.
 - e. Stainless steel mounting bracket and hardware.
 - f. Provide stainless steel drain/vent bleed valve and fitting at the connection point.
 - g. NSF 61 and 372 certified for drinking water approval
- E. Transmitter:
 1. Enclosure: NEMA 4X, epoxy covered aluminum housing and transmitter enclosure, rotatable.
 2. Accuracy: +0.25% of span.
 3. Rangeability: 10:1.
 4. Scale: Calibrated in appropriate engineering units, PSI. Coordinate with Engineer.
 5. Display: Multi field backlit LCD display.
 6. Output: A programmable pressure transmitter shall convert the pressure signal of the primary element into an appropriate 2-wire (loop powered) linear 4-20 mA signal proportional to the pressure input with HART Protocol. The electronics shall employ temperature compensation features. The output shall be isolated linear and be capable of driving 0-600 ohms.
 7. Connection shall be 1/2" NPT connections.
- F. Accessories:

1. Provide glycerin filled, or equal, diaphragm seal.
 - a. Process connection 2" NPT.
 - b. Instrument connection ½" NPT.
- G. Adjustments: The field adjustments required shall be zero and span, and they shall be adjustable without the use of additional equipment. Adjustments and calibration of the equipment shall not require a configurator, unless one is supplied.
- H. Provide block and bleed type pressure manifold for new transmitters. The valve manifold shall have stainless steel body and seat with Teflon packing/seals. Route block and bleed drain piping to floor.
 1. Manufacturers: Rosemount #0306RT23AA11
- I. Mounting:
 1. The sensor shall be mounted per the manufacturer's recommendations. Provide bracket(s) and hardware as required.
- J. Warranty: 5 years standard.
- K. Manufacturers: Rosemount #3051TG2A2B31ABLEB4Q4D1M6DW

2.03 LEVEL TRANSMITTERS (LE/LIT)

- A. Transmitter units (a submersible level transmitter with the associated sensing element) supplied under this Contract shall conform to the following Specification unless otherwise noted.
- B. Operating Range:
 1. 0 – 69.2 feet
- C. Sensor and Transmitter Performance:
 1. Accuracy: The electronics shall employ all digital microprocessor based electronics to insure an accuracy of measurement of +0.25% of span or less.
 2. This accuracy capability will range from 10% to 100% of pressure.
 3. Stability: less than 0.05% of URL, per year for 5 years.
- D. Pressure Sensor:
 1. Material:
 - a. AISI 316L Stainless steel wetted parts and diaphragm.
 - b. Viton O-rings.
 - c. Mineral oil fill fluid, or as required for approval.
 - d. Stainless steel mounting bracket and hardware.
 - e. Provide stainless steel drain/vent bleed valve and fitting at the connection point.
 - f. NSF 61 and 372 certified
- E. Transmitter:
 8. Enclosure: NEMA 4X, epoxy covered aluminum housing and transmitter enclosure, rotatable.
 9. Accuracy: +0.5% of span.
 10. Rangeability: 2:1.
 11. Scale: Calibrated in appropriate engineering units, PSI. Coordinate with Engineer.
 12. Output: A programmable pressure transmitter shall convert the pressure signal of the primary element into an appropriate 2-wire (loop powered) linear 4-20 mA signal proportional to the pressure input. The electronics shall employ temperature compensation features. The output shall be isolated linear and be capable of driving 0-1400 ohms.
 13. Connection shall be ½" NPT connections.

- F. Accessories:
 - 2. Provide glycerin filled, or equal, diaphragm seal.
 - 3. Instrument connection ½" NPT.
 - G. Adjustments: The field adjustments required shall be zero and span, and they shall be adjustable without the use of additional equipment. Adjustments and calibration of the equipment shall not require a configurator, unless one is supplied.
 - H. Mounting:
 - 1. The sensor shall be mounted per the manufacturer's recommendations. Provide bracket(s) and hardware as required.
 - I. Warranty: 5 years standard.
 - J. Manufacturers: Ametek 575M or Engineer approved equal.
- 2.04 TEMPERATURE TRANSMITTER (TE/TT)
- A. Continuous Temperature Measurement:
 - 1. Temperature Transmitter:
 - a. Power: 4-wire, 1-36 VDC.
 - b. Output: 4-20 mA dc proportional to measured temperature with HART protocol.
 - c. Isolation: 500 VDC.
 - d. Zero Drift: <0.005%/degree C.
 - e. Span Drift: <0.005%/degree C.
 - f. Accuracy: 0.1% of span.
 - g. Sensor Lead Resistance: 10,000 ohms maximum.
 - h. Open Circuit protection: upscale or downscale selectable.
 - i. Stability: 0.1% reading.
 - j. Materials of Construction:
 - 1) Enclosure:
 - a) Housing: 316 Stainless Steel.
 - b) Paint: Polyurethane.
 - c) 1/2-inch NPT conduit entry.
 - d) Rating: NEMA 4X.
 - k. Manufacturer: Rosemount #644HANAJ6M4F6Q4XA
 - 2. Sensor:
 - a. Range: -50 to 450 degrees C.
 - b. Surface mount sensor for steel pipe designed to measure internal fluid.
 - c. 1/8-inch diameter type T thermocouple grounded junction.
 - d. Thermocouple brazed in to a 2-inch x 2-inch x 0.034-inch thick, 304 SS heat collecting pad, brazed to a flat tipped, grounded junction Style "F" Sensor attached into a spring steel clamp for mounting.
 - e. Submit calibration certificate.
 - f. Manufacturer: Rosemount #214CRTSMB1S4E0062SLXAXW
 - 3. Thermowell:
 - a. Mount sensor to measure internal piping temperatures.
 - b. Provide device with 5-year warranty.
 - c. Immersion length of 4-inches with tapered stem style.
 - d. Process connection 3/4-14 NPT.
 - e. Head Length of 2.2-inch.
 - f. Material: 316/316L Stainless steel

- g. Manufacturer: Rosemount #114CE0040TAB2SC022AXW

PART 3 - EXECUTION

3.01 INSTALLATION

- A. Install the control and instrumentation in accordance with drawings, shop drawings, and manufacturer's recommendations.
- B. Low power DC control signal wires shall be shielded and installed in a separate steel raceway. No AC power or control wires are allowed in the same raceway. The shielded control wires shall be sized to be compatible with the distances involved and the equipment selected.
- C. AC control wires shall be in separate conduit and sized to keep voltage drop within acceptable limits.
- D. All wiring terminating in control panel or other devices shall be properly identified with one-piece wrap on sleeve type tags or labels with machine lettering.
- E. Before any circuits are energized, all internal and external electrical and mechanical clearances shall be checked to ensure all installed equipment will function safely and properly.

END OF SECTION

PART 1 - GENERAL

1.01 RELATED DOCUMENTS

- A. Drawings and general provisions of the contract, including General and Supplementary Conditions and Division 01 Specification sections, apply to this section. If differing requirements are identified elsewhere (in these specifications or on drawings or separate instructions), the more stringent requirement shall be met.

1.02 DESCRIPTION

- A. The work of this section includes provisions for a proposed control panel for proposed well pump system to be controlled and operated from existing water treatment facility.
- B. The scope of work pertaining to this section includes but is not limited to the following major control items:
 - 1. Born Court Wellhouse
 - a. Provide proposed "well 1-7 control panel" as indicated and as required.
 - 2. Water Treatment Facility:
 - a. Modify to existing SCADA system as indicated and as required and as follows:
 - 1) Wiring modifications, wiring, and terminal strips as required.
 - 2) Fiber optic connection to plant SCADA network and integration of controls with existing SCADA system.
- C. The requirements and specifications listed herein pertain to, but not limited to the following types of control stations and enclosures:
 - 1. Existing SCADA telemetry
 - 2. Proposed well 1-7 control panel.
- D. This specification is intended to provide a guideline for the modifications inside existing control enclosures and cabinets. Not all enclosures will require every specified hardware component listed herein. Please confirm panel requirements with Division 40 and the drawings.
- E. SCADA system operates on the Rockwell CompactLogix platform and is intended to be modified to incorporate the proposed alarm, control, and monitoring points.
- F. Refer to Appendix A of this section for proposed I/O points list to be incorporated into the existing SCADA system.
- G. SCADA system programming and integration shall be performed by Stephen Lozen of Tetra Tech [Stephen.lozen@tetrattech.com, (734) 218-6223].

1.03 RELATED WORK

- A. Section 26 05 00 - Electrical General Provisions

1.04 SUBMITTALS

- A. Submit under provision of Division 1.
- B. Provide shop drawings and product data for all items approval data is required for:
 - 1. Control Panel
 - 2. Control relays and timers.
 - 3. Wiring terminal strips.
 - 4. PLC remote I/O modules

5. Motor Starters & Contactors
 6. Generator receptacle
 7. Miscellaneous wiring devices (receptacles, door switches, thermostats, light switches, etc.)
 8. Other control system components, interface, and indicating devices, etc.
 9. Other major devices in control panel
- C. Provide electrical diagrams and layout arrangement diagrams for approval. Include ladder logic diagrams with rung numbers, conductor and terminal number, coil function description, contact references and cross-references, timer settings, and device location. Documentation of existing control panels may not exist or be available to the Contractor. Create existing diagrams to the extent required to document work required.
- D. Provide complete control panel information for approval including:
1. Scaled and dimensioned fabrication and layout drawings.
 2. Detailed device bill of material referencing use and location.
 3. Schematic wiring control diagrams in ladder logic type format. Diagrams shall include rung numbers. Conductor and terminal number, coil function description, contact references and cross references, timer settings, and type device.
- E. At project substantial completion, per Division 1, provide operation and maintenance manuals bound in a spiral hard cover binder containing detailed record drawings as provided above and renewal parts information including source location and maintenance recommendations.

1.05 SPECIAL PROVISIONS

- A. The CONTRACTOR shall engage the services of:
1. A specialty custom panel builder with experience in the water and wastewater field to supply the station control panel. Qualifications of the panel builder are outlined below:
 2. A control and instrumentation subcontractor with experience in installation of control systems in the water and wastewater field with qualification outlined below:
- B. The control panel shall be fabricated and assembled by a vendor fabricator regularly and routinely in the special control panel business. Furnish documentation for the control panel is listed below:
1. Complete bill of material of all electrical and physical components mounted in or on the control panel. Bill of materials shall include a full component description, manufacturer and complete part number for each component.
 2. Dimensioned elevation drawings that show panel size and locations of all internal and external mounted electrical components. All components shall be noted with an identification reference back to the bill of materials.
 3. Three-line power wiring diagrams and control wiring diagrams. Wiring diagrams shall include proper nomenclature that reference back to the bill of material. All wiring diagrams shall include standard vertical line numbering that incorporates the drawing number for reference purposes throughout the entire drawing set (i.e., Sheet 1, line 10 = line number 110). All control relays shown in diagrams shall include line number reference at relay to indicate connection location of relays contacts (underline line number reference for normally-closed contacts).
- C. All control and instrumentation hardware items shall be furnished but not necessarily manufactured by a single supplier who has had a minimum of two years of experience in the manufacture of controls of the type specified herein and who has furnished and installed similar controls in at least three water control systems.
- D. The custom panel builder and control and instrumentation subcontractor shall have experience in the water and wastewater field. Specifically, these organizations and individuals shall have been

involved in construction and start-up of control and instrumentation on a minimum of three water or wastewater systems or more.

1.06 DELIVERY, STORAGE AND HANDLING

- A. All equipment shall be stored and protected from dampness and humidity during construction.
- B. Touch up or refinish damaged paint. Replace any equipment damaged or affected by dampness/wetness.

PART 2 – PRODUCTS

2.01 GENERAL

- A. Functionally similar components shall be products of a single manufacturer.

2.02 EXTERIOR CONTROL PANELS:

- A. Control Panels shall be furnished and installed as shown on the drawings and in the Special Provisions.
- B. Control Panels shall be free standing, vented NEMA 3R type. Panels shall be fabricated from mild steel, welded construction with strut channel or angle iron reinforcement frame. Panels shall be painted white. Front doors shall be the full height of the panel, pan type with steel piano hinges with mechanical hold open devices and three-point latching handles with defeater mechanism. Provide a double-hinged padlock hasp. Panels shall be manufactured by Saginaw Controls and Engineering, Hoffman, B-Line or 'Approved' equal.
- C. Control panel shall have interior doors constructed of 12-gauge stainless steel with continuous hinge for mounting interior disconnect switch handle, ammeter display, elapsed time meter, pushbuttons, pilot lights, and any digital displays.
- D. Panel cutouts shall be located as shown and in accordance with best panel design standards. Suitable internal front panel stiffeners shall be installed as required to prevent buckling and maintain a flat surface. All digital meter displays, ETMs, etc. shall be mounted at eye level.
- E. Panel interiors shall be white. Panel exterior surface shall be gray.
- F. The panel interior shall have a GFCI duplex convenience outlet as shown.
- G. Panels shall have sufficient print pockets inside the access doors or panels to hold detailed wiring and interconnect diagrams. One copy of the relevant drawings shall be provided and placed in these pockets. An additional copy of detailed wiring and interconnect diagrams shall be laminated and mounted on inside surface of outer door.
- H. Gray slotted plastic wire duct shall be used to route AC/DC wiring within the panels. Blue slotted plastic wire duct, marked 'INTRINSICALLY SAFE WIRING ONLY', shall be used to route intrinsically safe (IS) wiring within the panels. Wire duct shall be run in continuous length with Snap-On covers. Minimum size 2"W x 2"D. Slotted plastic wire duct shall be as manufactured by Panduit, Wire Mold, or equal.
- I. The panels shall be provided with separate terminal blocks for all power, signal and control wiring to be connected to field mounted devices and circuits entering or leaving the panel. Ten percent spare terminals shall be provided.

- J. Panels shall come equipped with door switched, 120VAC, LED panel light, located in top of enclosure. Light fixture shall provide a minimum of 300 lumens.
- K. Nameplates shall be black plastic laminate with white filled legend engraving. Nameplates shall be adhesive attached.
- L. Panels shall be sized to allow 20% additions and modifications.
- M. Provide 1" x 6" x 1/4" solid copper ground bar, minimum. Bus bar shall be sized as required to provide space to conveniently terminate each ground connection to the grounding electrode/grounding electrode system. Mount ground bus on insulated bracket.
- N. Provide universal ground bar with length as required to provide space to individually terminate each ground wire plus 10% spare space.
- O. The panel shall be design to allow for a minimum of 5" clearance at the bottom of the panel for field wiring and terminations. All permanently mounted devices shall be above this area.
- P. Provide all labeling as required by NEC, NFPA, OSHA and UL 698A including arc flash labeling required by the NEC Code.

2.03 CONTROL PANEL WIRING SYSTEMS

- A. Internal control panel wiring shall be provided as specified in Section 26 05 19.
- B. Wiring Terminal Blocks:
 - 1. Terminal blocks shall be rated as a minimum for the following:
 - a. 120V AC & DC wiring – 300VAC, 15A.
 - b. UL Listed per UL 486E and UL1059.
 - 2. Terminal blocks screw terminal type with barriers between each set of terminals and individual termination points for each conductor. Terminals shall be nickel plated with stainless steel screws. Terminals shall be housed in an insulated finger-safe housing. Terminal blocks shall be a single level block. Wire size terminal range should be a minimum #22 AWG to #12 AWG.
 - 3. The panels shall be provided with separate terminal blocks for all power, signal and control wiring to be connected to field mounted devices and circuits entering or leaving the panel. Ten percent spare terminals shall be provided.
 - 4. Terminal strips shall be suitable for DIN rail mounting on the same channel as relays, starters, and contactors. Terminal blocks shall come with end stops, end barriers, jumpers as required.
 - 5. Identify terminal strips with permanent labels.
 - 6. Provide ground style terminal blocks for ground wiring in panels. Terminal block shall be specifically color coded (green/yellow striped).
 - 7. Terminal block color coding:
 - a. Gray: Standard control internal & field wiring
 - b. Black: 120V control power wiring
 - c. White: 120V neutral wiring
 - d. Blue: Intrinsically safe wiring
 - e. Green/Yellow: Ground wiring
 - 8. Design based on Allen-Bradley or equal by Panduit, Phoenix Contact, or Square D.
- C. Gray slotted plastic wire duct shall be used to route AC/DC wiring within the panels. Wire duct shall be run in continuous length with Snap-On covers. Minimum size 2"Wx2"D. Slotted plastic wire duct shall be as manufactured by Panduit, Wire Mold, or equal

- D. Provide separate 6" (minimum) copper ground bar in panel for grounding requirements in the panel. Size ground bus for a maximum of one conductor per lug/terminal.

2.04 CONTROL RELAYS

- A. Control and Auxiliary Relays: Provide plastic enclosed plug-in with contacts rated not less than 10 amperes at 120VAC contact arrangement to be double pole or three-pole, as required, double throw. Plug-in sockets to be 8-pin or 11-pin tube type with screw terminals for mounting on DIN rail or backplates. Acceptable manufacturers are Allen-Bradley, Square D, Potter Brumfield, or Idec.

2.05 PLC CONTROL SYSTEM

- A. General:
 - 1. General: All new PLC components shall be compatible with the existing City of Kalamazoo telemetry system. Contractor shall verify system configuration with the Owner/City of Kalamazoo. Programming shall be by Owner/City of Kalamazoo.
 - 2. Provide Allen Bradley CompactLogix remote I/O module to interface with existing PLC controller within water treatment plant. Provide IO expansion cards equipped with all components, single or multiple power supplies as required by the application and all IO interface cards, wiring terminals, racks, rack cabling and rack dividers, end-caps and terminators as required, as well as with communication cables for a complete control system. Equipment shall be adjusted as required where compatibility and interaction with other specified components are limited or are not supported by the manufacturer.
 - a. Terminal blocks: 4x - 5069-RTB18-SCREW RTB, 1x – 5069-RTB5-SCREW
 - b. Ethernet adaptor: 5069-AENTR
 - c. 24Vdc input module: 5069-IB16
 - d. 24Vdc output module: 5069-OB16
 - e. Analog input module: 5069-IF4IH
 - f. Analog output module: 5069-OF4

2.06 PANEL HEATERS:

- A. Heater kW output shall be sized to maintain a temperature within the panel for electronic devices (Soft Starters, transmitters, pump controller, etc.) to properly operate within specification during normal ambient conditions for the cold season. Minimum rating shall be 400 watts.
- B. Electric heaters should be centered as low as possible on an interior enclosure panel.
- C. For maximum efficiency and longevity, the heater should be mounted in a vertical position with the terminal block to the bottom and the air outlet openings at the top in a sealed enclosure free from dust or debris
- D. Do not install heaters on wood panels.
- E. Heat sensitive components should not be placed near the heater discharge area.
- F. Electric heaters are not designed for use in dusty, dirty, corrosive, or hazardous locations.
- G. Heater can only be installed in a totally enclosed metal enclosure.
- H. Heater shall be manufactured by Hoffman or equal.

2.07 COOLING FANS:

- A. Cooling Fan Package shall include fan, air filter, composite air plenum, finger guard, and grille.
- B. Air filter shall provide good arrestment of airborne dirt with minimal pressure drop.
- C. Durable composite air plenum and grille shall take up minimal enclosure space. Plenum shall permit even airflow through the filter for maximum filtering efficiency. Unit shall contain an integral and removable finger guard on either side of the plenum.
- D. Air filters shall be accessible for cleaning from outside the enclosure.
- E. Fan impellers shall be dynamically balanced and molded from polycarbonate material.
- F. Cooling fan shall provide a minimum CFM to provide heat relief for soft starters and other electronic devices to prevent overheating.
- G. Fan shall conform to UL 508, CSA and CE standards.
- H. Cooling fan shall be manufactured by Hoffman, SCE, or approved equal.

2.08 LOUVERS:

- A. Louvers shall provide ventilation in enclosure to reduce excessive internal heat or moisture.
- B. Louver plates shall be made from 14-gauge steel with an ANSI 61 gray polyester powder finish over phosphatized surfaces.
- C. Louver shall be furnished with necessary hardware mounting.
- D. Louver shall be furnished with washable aluminum air filter.
- E. Louver shall be manufactured by Hoffman, SCE or approved equal.
- F. Provide sealed painted metal rain shroud around perimeter of louver frame to prevent exposure to rain and snow. Shroud shall be fabricated to match similar metals to enclosure.
- G. Louver shall be manufactured by Hoffman, SCE or approved equal.

2.09 TERMINAL BLOCKS:

- A. Provide 35mm DIN rail (channel) mount terminal blocks, as required, rated at 300V, 30A maximum, for interconnections with field equipment.
- B. Terminal blocks shall be sectional type, have white marking strip for numbered identification, connections, recessed screw heads compression clamp, test point and comb type jumper(s).
- C. Segregate terminal blocks used for DC signals, AC control and power wires.
- D. Power distribution blocks (PDB) shall be used as required for 480 V power distribution wiring within the panel or enclosure. Power distribution blocks shall be sized according to wiring requirements in the panel.
- E. Allen-Bradley Model 1492 terminal blocks.

2.10 SURGE PROTECTION DEVICES (SPD):

- A. General Requirements:
 - 1. Tested for 10,000 operations of simulated lightning wave shapes.
 - 2. The case shall be constructed of aluminum.
 - 3. Low Voltage Lightning and 480VAC Delta Three-Phase Surge Suppression:
 - a. System shall be rated for 600 volt maximum.
 - b. Able to withstand individual strokes of over 40,000 amps without deterioration.
 - c. System shall be listed and labeled by U.L.
 - d. Manufacturer: Transtector model I2R SA240D or approved equal.
 - 4. Low Voltage Lightning and 240VAC Single-Phase Surge Suppression:
 - 5. System shall be rated for 150 volt maximum.
 - 6. Able to withstand individual strokes of over 10,000 amps without deterioration.
 - 7. System shall be listed and labeled by U.L.
 - 8. Manufacturer: Transtector model I2R IEP 120-10 or approved equal.

2.11 ELAPSED TIME METERS:

- A. Meter shall be an odometer style, non-resettable 6-digit display.
- B. Meter shall be designed for panel mount applications.
- C. Shall be accurate to 0.025%
- D. Wire connections via spade type terminals.
- E. Manufacturers: Yokogawa 240 Series.

2.12 THERMOSTATS:

- A. Thermostats controlling electric heaters and cooling fans shall be heavy duty line voltage rated 16 amps at 120V for pilot duty sized for the contactor coil load, adjustable range 45° F to 85° F.
- B. Single pole double throw suitable for energizing the electric heat load on falling temperature or energizing the electric cooling load on rising temperatures.
- C. The thermostat shall be Hoffman or equal by Honeywell or Chromalox.

2.13 FUSES:

- A. 250 V Fuses: Class J, one-end rejection or to fit mountings specified, 1/10 to 600 amps, 200,000 amp interrupting rating.
- B. Bussmann Low-Peak. LPN-R, dual element, time delay with short circuit protection for motor, transformer, welder, feeder, and main service protection.
- C. 600 V Fuses:
 - 1. Class RK 1, one-end rejection or to fit mountings specified, 1/10 to 600 amps, 200,000 amp interrupting rating. Bussmann Low-Peak, LPS-R, dual element, time delay with short circuit protection for motor, transformer, welder, feeder and main service protection.

2. Class CC, fast acting, single element, 1/10 to 30 amps, 200,000 amp interrupting rating. Bussmann Limitron KTK-R, UL listed for motor control circuits, lighting ballasts, control transformers, and street lighting fixtures
 3. Class L, bolt-in type, 601 to 6000 amps, 200,000 amp interrupting rating. Bussmann Hi-Cap, KRP-C, time delay for overload and short circuit protection for motor, transformer, feeder, and main service protection.
- D. Spare Fuses: for each type provide the following:
1. Power Fuses: One spare of each type and rating.
 2. Control Circuit Fuses: 10% or minimum of three (3) of each type and rating.
- E. Manufacturers: Bussmann, Gould Shawmut, or Littelfuse.
- 2.14 INDICATION DISPLAYS:

A. DIGITAL PANEL METERS

1. Inputs: Current (4-20mA), Voltage (0-10V), Thermocouple, RTD
2. Accuracy: +/- 0.05% FS +11 count; +/- 0.1% FS +/-2 counts for square root
3. Environment:
 - a. NEMA 4X, IP65, panel gasket provided
 - b. Operating temperature: -40 to 65°C (-40 to 149°F)
 - c. Storage Temperature: -40 to 85°C (-40 to 185°F)
 - d. Relative humidity: 0 to 90% non-condensing
4. Programming methods: four front panel buttons, cloning with Copy feature
5. Noise filter: Programmable 2 to 199
6. Display update rate: Process/RTD: 3.7-5/sec; TC: 1.8-2.5/sec
7. Password restriction capable
8. Settings stored for minimum of 10 years via non-volatile memory
9. Power supply: 12-36VDC; 12-24VAC, 6W max.
10. Dimensions: 4.68" x 2.45" x 4.19"
11. Manufacturer: Precision Digital model#PD765-7X0-00
12. Warranty: 3 years parts and labor

2.15 INDUSTRIAL ETHERNET SWITCHES:

- A. Unmanaged Ethernet switch:
1. Processing Type: Store and forward switching.
 2. Ports: 10/100 Mbps, 10Base-T/100Base-TX with auto crossing and auto negotiation. 5 port minimum, additional ports where indicated on the Drawings.
 3. Vibration, shock and humidity ratings shall be suitable for industrial use
 4. 0 °C to 60 °C (32 °F to 140 °F) operating temperature range
 5. Mounting: 35mm DIN rail. Provide additional brackets as required.
 6. 10-30 VDC nominal input voltage.
 7. Manufacturer: Belden (Hirschmann), Red-Lion (N-Tron Series), Antaira, Moxa, or equal by Cisco.

PART 3 - EXECUTION

3.01 INSTALLATION

- A. Terminate conduits in cabinet with lock nut and bushing.
- B. Install the control system in accordance with drawings, shop drawings, and manufacturer's recommendations.

- C. Provide isolation relays as required where signal or voltage from remote devices are incompatible with and/or cannot be wired directly to control panel component.
- D. Low power DC control signal wires shall be shielded and installed in a separate steel raceway. No AC power or control wires are allowed in the same raceway. The shielded control wires shall be sized to be compatible with the distances involved and the equipment selected.
- E. AC control wires shall be in separate conduit and sized to keep voltage drop within acceptable limits.
- F. All wiring terminating in control panel or other devices shall be properly identified with one-piece wrap on sleeve type tags or labels with machine lettering.

3.02 FINAL START-UP AND DEMONSTRATION

- A. Provide the services of an experienced, competent service engineer for a minimum of four 4-hour days not including travel time for start-up assistance. Service engineer shall be responsible for:
 - B. Checking the installation including wiring and connections.
 - C. Executing a complete start up demonstrating the operation of the equipment to the Owner.
 - D. All modes of operation and alarm annunciation shall be demonstrated.
 - E. Contractor shall conduct a Final Start Up and Demonstration of the system. It is mandatory that the Contractor shall have the instrumentation contractor and electrical contractor onsite the day of the final start up.
 - F. Contractor shall provide written notice to the Owner's Representative and Controls and Instrumentation Contractor forty-eight (48) hours in advance of intended start-up visit.

3.03 Process Control IO List:

- A. Refer to Appendix A of this section for the proposed I/O list.

END OF SECTION

CONTROL PANEL	SCADA EQUIPMENT TYPE	Signal Type	DESCRIPTION	I/O TYPE	Indication	Alarm	Totalize	Historize
Well House CP Signals								
CP	Remote I/O	24VDC	Well Pump Running	DI	X		X	X
CP	Remote I/O	24VDC	Well Pump Fault	DI	X	X		
CP	Remote I/O	24VDC	Heat Trace Fault Alarm	DI	X	X		
CP	Remote I/O	24VDC	Call for Well Pump to Run	DO	X			
CP	Remote I/O	4-20mA	Well Level	AI	X	X		X
CP	Remote I/O	4-20mA	Well Temperature	AI	X	X		X
CP	Remote I/O	4-20mA HART	Outflow flow rate	AI	X	X	X	X
CP	Remote I/O	4-20mA	Outflow Pressure	AI	X	X		X
CP	Remote I/O	4-20mA	Outflow flow rate to display	AO	X			
CP	Remote I/O	4-20mA	Outflow Pressure to display	AO	X			
CP	Remote I/O	4-20mA	Well level	AO	X			

Exhibit 1

City of Kalamazoo Work Practice – Water Facility Enter



WORK PRACTICE

City of Kalamazoo
Public Services Department

WP Number: WP wsuppy010	Computer Path: M:\Public Services\Water Supply\Work Practices
Title: Water Facility Enter	Written By: Brock VanDyken Date: 06/13/2023
	Reviewed By: Date:
	Approved By: Joe Bonhomme Date: 06/14/2023

I. PURPOSE AND SCOPE:

The Purpose of this work practice document is to provide steps necessary to ensure better Water Supply Facility security and knowledge of who is entering facilities and for what purpose. This document does not give location of buttons, timers, or keypads for entry alarms. This information can be obtained from Water Supply (337-8179).

II. REQUIREMENTS

- A. Permission to perform work in or around Water Supply Facilities.
- B. Notification to Water Supply of who is entering which facility. So that we know that entrants are authorized to do so and for what reason.
- C. Knowledge of where to find and how to use the alarm deactivation device.

III. DEFINITIONS

Public Services Personnel – This includes but is not limited to: Well Drillers, Water Maintenance, Lab Techs, Process Control, Electricians, Water Supply, Engineering, Utility Locators, Building Maintenance, and all others doing work in and around these facilities.

Water Supply Facility – Includes any water pumping station, storage tank, boost/bleed station, pit, or any other water facility.

Normal hours – 7:00 AM to 3:30 PM

After hours – 3:30 PM to 7:00 AM

IV. RESPONSIBILITIES:

During normal hours all **Public Services Personnel, Private Contractors, and Consultants** are to contact Water Supply by Phone (337-8179), before entering any Kalamazoo Water Supply Facility. Call Water Supply (337-8179) to make sure all alarms are reset, and the area is secure before you leave. After hours **ALL** persons are to contact **Water Supply** on-call Personnel by phone (337-8874) before entering any Kalamazoo Water Supply Facility.

V. PROCEDURE:

Proper procedure for all persons entering and exiting water facilities in the field.

1. Prior to entry
 - A. During normal operating hours call Water Supply (337-8179) on which facility you are entering.
 - B. After hours call Water Supply on-call Personnel (337-8874) on which facility you are entering.
2. Open door or hatch and enter.
3. Press button, keypad or turn time to deactivate alarm mode. You will have 30 seconds to complete the circuit.
 - A. If you don't actuate the alarm defeat device, Water Supply will consider you under duress and will call 911 to have the police come and checkout the situation.
 - B. If you need to work at the station for an extended period of time call Water Supply so that they can override the alarm timer on SCADA.
 - 337-8179 – during normal operating hours
 - 337-8874 – after hours
4. Shut doors or any other openings that you passed through and lock up. Call Water Supply to make sure all alarms are reset, and the area is secure before you leave.
 - A. 337-8179 – during normal operating hours
 - B. 337-8874 – after hours

VI. REFERENCES:

VII. WORK PRACTICE REVISION HISOTRY:

Revision	Date	Approval

Appendix C

Standard Specifications

SECTION 2

SPECIFICATIONS FOR EXCAVATING, TRENCHING, & BACKFILLING FOR UTILITIES

2.01 DESCRIPTION OF WORK

The work must consist of furnishing all materials, equipment, and labor for excavating, trenching, and backfilling for utilities. The work also must include the necessary clearing, sheeting and shoring, boring and jacking, dewatering, pipe embedment, and other appurtenant work.

The work must be performed in accordance with the specifications and drawings, the MDOT 2020 Standard Specifications for Construction and the following specifications.

2.02 CLEARING, BRUSHING & TREE REMOVAL

2.02.01 General

The Contractor must perform all clearing, brushing, and tree removal required for the proposed construction. Where indicated on the drawings for a specific area, that area must be completely cleared in accordance with Sections 201 and 202 of the MDOT 2020 Standard Specifications for Construction. The Contractor must notify the Engineer 48 hours (two working days) prior to commencement of clearing, brushing and tree removal. Clearing and brushing must be confined to the limits of the right-of-way or easements unless otherwise directed and must be kept to a practicable minimum.

Trees marked "Remove" on the drawings must be taken down and removed from the right-of-way in a manner that does not endanger the adjoining property or persons or traffic using the right-of-way. Unless approved otherwise by the Engineer, stumps of trees are to be removed. All stump removal must be considered included in the major items of work to the project.

Selective pruning of trees will be permitted to allow operation of the Contractor's equipment. Trees must be pruned neatly, and the scars from pruning or other damage by the Contractor's equipment must be covered with a preservative.

Tree removal and clearing must be performed in accordance with Federal, State, and Local requirements including seasonal limitations. If work cannot be completed within seasonal limitations, and additional evaluation is required to proceed, the Contractor must pay for such services.

2.02.02 Preservation of Trees

Because of the special concern for preservation of trees, all trees six (6) inches in diameter and larger, measured at a point 4-1/2' above the ground line at the base of the

tree, which are to be removed have been marked on the drawings. Where there is more than one tree that has grown from a common stump, each tree is measured as a separate tree. All other trees are to be preserved unless written permission for removal is obtained from the Owner and/or the Engineer. Where tunneling is necessary to preserve a tree, it must be included in the major items of work. Trees that may have to be tunneled may or may not be specified on the drawings. Where tunneling is necessary, excavation may have to be done by hand to prevent damage to the tree or to its roots. When tunneling or excavating is done close to a tree to be preserved, every effort must be made to preserve the main roots.

2.02.03 Disposal of Debris

All trees, brush, and stumps from clearing and brushing operations must be disposed of by the Contractor by hauling from the site, or other suitable means approved by the Engineer. Burning of debris will be allowed if approved by the Engineer and Owner. The Contractor must obtain the necessary burning permits and must comply with the safety regulations required.

2.02.04 Measurement & Payment

The cost of all clearing, brushing, tunneling, and protection of trees which are left standing must be considered included in the major items of work unless specific items have been provided in the Proposal in which case the prices must be payment in full for performing this work as specified herein. All tree preservation must be included in the major items of work to the project. Trees will be measured at a point 4-1/2' above the ground line at the base of the tree. Where more than one tree has grown from a common stump, each tree is measured as a separate tree. Trees smaller than six (6) inches in diameter will not be considered pay items.

2.03 REMOVAL OF SURFACE IMPROVEMENTS

Surface improvements such as sidewalks, improved lawns, drives, curb and gutter, and all types of pavement must be removed just prior to excavating or trenching operations. All improvements must be cut at the expected trench width prior to excavating using suitable equipment which does not damage the improvement outside of the trench area.

Concrete and bituminous pavement and drives must be cut with a pavement cutting saw. The depth of the cut must be the full depth of the pavement. Pavement crushers or breakers of any type are prohibited unless specifically authorized by the Engineer. Pavement which is removed must not become mixed with backfill material. Power equipment may be used for pavement removal, provided that damage is not caused to improvements which are to remain.

Removal of surface improvements must be included in the major items of work and no specific payment will be made therefore unless specific Proposal items are provided, in which case the prices bid must be payment in full for performing this work as specified herein.

2.04 EXISTING SOIL / SUBSURFACE CONDITIONS

Where provided, the soil borings shown on the construction drawings are being furnished for the convenience and general information only. The data shown on the boring logs represents soil and ground water conditions encountered at the respective boring locations at the time of boring. Variations may occur between these locations. Additionally, the stratigraphic lines represent the approximate boundaries between soil types; however, transitions may be more gradual than what is shown. The Contractor will be responsible for making themselves familiar with subsurface conditions by whatever means they deem necessary and shall make their own determinations therefrom.

2.05 EXISTING UNDERGROUND UTILITIES & STRUCTURES

2.05.01 Location

No less than three (3) working days prior to excavating, the Contractor is to call “MISS DIG” at 1-800-482-7171 or 811. Existing utilities are shown only at their approximate locations based on information and data furnished to the Engineer by the owners of such underground facilities. Neither the Engineer nor the Owner guarantees the accuracy or completeness of any such information or data. The Contractor must be solely responsible for determining their exact elevations and location in the field. The Contractor must notify the owners of all underground utilities before starting any work. House sewer connections, water and gas services, and other utility lines may not be indicated on the drawings. However, the Contractor must make every effort to locate all underground utilities from information obtained from the utility owner or by prospecting in advance of trench excavation.

2.05.02 Replacement

Certain underground utilities such as sewers may require removal and subsequent replacement in lieu of supporting or bracing during the proposed construction, or the Contractor may elect this option when temporary provisions to maintain essential services have been previously approved by the Engineer.

Unless otherwise specified, any utilities removed during the proposed construction must be replaced by the Contractor. Materials and installation must be equal to or better than original construction in every way. Salvaged materials may be reused when they are in good condition, and a satisfactory installation can be accomplished in the judgment of the Engineer.

Replacement of existing utilities must be considered included in the major items of work unless specific items have been provided in the Proposal, in which case the prices bid must be payment in full for performing this work as specified herein.

2.05.03 Relocation

Should any pipe or other existing utility require raising or lowering or moving to another location because of interference with the pipe or structure being constructed under these specifications, such changes which in the opinion of the Engineer are necessary must be made by the Contractor unless otherwise specified. Relocation of the utility shall be coordinated with the utility owner and comply to their requirements. Relocation of existing utilities must be included in the major items of work unless specific items are provided in the Proposal.

2.05.04 Reconnection

Where lateral services, house connections, or other pipelines require reconnection to the proposed utility, as is the case when an existing utility is being reconstructed, the Contractor must make these connections as specified or as shown on the drawings. All costs for making these connections, including provisions for maintaining flows and providing temporary service during the proposed construction, must be included in the major items of work unless specific items are provided in the Proposal.

2.05.05 Utilities to be Abandoned

When pipes, conduits, sewers, or other structures are removed from the trench leaving dead ends in the ground, such ends must be fully plugged or sealed with brick and mortar by the Contractor to obtain a soil-tight condition. Abandoned structures such as manholes or chambers must be entirely removed unless otherwise specified or shown on the drawings.

All materials from abandoned utilities which can be readily salvaged must be removed from the excavation by the Contractor and stored on the site or loaded on the Owner's truck as directed by the Engineer. Owner must have first claim to salvageable materials. The Contractor is responsible to dispose of salvageable materials not desired to be kept by the Owner.

All costs for abandoning utilities and for removing and salvaging materials, when required, must be considered included in the major items of work unless specific items have been provided in the Proposal, in which case the prices bid must be payment in full for performing this work as specified herein.

2.06 EXCAVATING & TRENCHING

2.06.01 General

Excavating and trenching operations must at all times be conducted in a safe, orderly manner using methods and equipment designed and suited to the intended use by personnel experienced in the work being performed.

None of the requirements or provisions specified herein or shown on the drawings must nullify or restrict any safety provisions required by any regulation or law governing the protection and/or safety of persons or property.

2.06.02 Width of Trench

The width of the trench must be ample to permit the pipe to be laid and joined properly and the pipe embedment material and backfill to be placed and compacted per pipe manufacturer's recommendations. Trenches must be of sufficient extra width when required as will permit the convenient placing of trench supports, sheeting, and bracing.

When the trench width above the top of the pipe is appreciably greater than that which is reasonably required by project conditions in the judgment of the Engineer, any additional cost for backfill material, surface restoration, or other items that are the result of such excess width must be borne by the Contractor.

When installing pipes in areas of rock, refer to section 2.06.05 for minimum trench clearance.

2.06.02.01 Width of Trench for Rigid Pipe

In order to limit excessive loads on rigid pipe, the maximum width of trench for pipe 36 inches and larger in diameter must not be more than twice the nominal diameter. For smaller sizes of pipe, the maximum width of trench must be not more than 3 feet greater than the nominal diameter of the pipe except as otherwise specified or directed. The above limiting restrictions on trench width apply from outside bottom of pipe to outside top of pipe.

Where the width of trench within these limits exceeds the maximum limit specified, the Contractor must install a heavier class of pipe or use other means to provide additional load-carrying capacity at no additional cost to the Owner. Any changes in class of pipe or other variation must be approved in writing by the Engineer before the work progresses.

2.06.02.02 Width of Trench for Flexible Pipe

Unless otherwise specified or approved by the Engineer, the minimum width of trench must be per pipe manufacturer's recommendation based on the pipe material, native soil conditions, and selected embedment material, or the minimum width to achieve specified compaction, whichever is greater.

2.06.03 Excavating to Grade

The trench must be excavated to a depth required for the proper installation of the pipe and placing of the pipe embedment material as specified.

Any part of the bottom of the trench excavated below the specified subgrade must be refilled with approved materials compacted to 95% of maximum unit weight in accordance with MDOT procedures at no additional cost to the Owner. If additional excavation is required to correct unstable foundation conditions, payment will be made as specified in Section 2.07.

2.06.04 Sheeting, Shoring, Bracing, & Shelving

2.06.04.01 General

The Contractor must brace or slope back the sides of all excavations in accordance with current MIOSHA regulations. The Contractor must be responsible for compliance to such regulations and for the design, installation, and maintenance of all excavation safety measures.

2.06.04.02 Measurement & Payment

Unless otherwise specified in the Proposal, the costs incurred in the installation of bracing, sheeting, shoring, and shelving must be included in the unit price bid for the work being performed.

If during the course of construction, field conditions require sheeting to be left in place as directed by the Engineer, the Engineer will negotiate payment with the Contractor in accordance with the contract provisions for extra work unless specific items have been provided in the Proposal.

2.06.05 Rock Excavation

2.06.05.01 General

Wherever the word rock is used in these specifications, it means boulders, solid ledge rock, and other minerals geologically placed and of a hardness when first exposed of 3 or greater in scales of mineral hardness, which in the opinion of the Engineer requires continuous use of drilling and blasting or special power equipment for its removal.

Soft disintegrated rock which can be removed with a power-operated excavator or with hand tools and loose, shaken, or previously blasted rock and broken stone in rock fillings will not be classified as rock, nor will it be included in measurements for payment.

2.06.05.02 Hardness

The Engineer will determine the hardness of the material or minerals in question. The following accepted hardness will be used as a guide in the field for specific situations:

- Gypsum - hardness of 2
- Fingernail - hardness of approximately 2-1/2
- Calcite - hardness of 3
- Copper Coin - hardness of approximately 3
- Brass Pin - hardness of approximately 3

A mineral with a hardness of 3 will scratch a copper coin and can be scratched with a brass pin. Determinations of hardness which cannot readily be determined in the field will be resolved by laboratory analysis of the material in question.

2.06.05.03 Blasting

Where blasting is necessary, the Contractor must obtain the required permits and licenses at its own expense. This work must be done with due regard to the safety of workmen, other people, and public and private property. The method of covering blasts, amounts of charges used, and the general procedure for doing this work must conform to the standard practice and must meet all requirements of local ordinances and other regulations and will be subject to the approval of the Engineer.

2.06.05.04 Clearance

Rock must be removed to provide a clearance for all pipes, appurtenances, or structures of at least eight (8) inches below, and a minimum of eight (8) inches on each side of the pipe, appurtenance, or structure.

The specified minimum clearances are the minimum clear distance which will be permitted between any part of the pipe or appurtenances being laid and any part, point, or projection of the rock.

2.06.05.05 Measurement

Only boulders of 1 cubic yard or greater in volume that cannot be removed with power excavating equipment or rock as defined herein will be measured for payment. Measurements of rock will be made by the Engineer after rock is removed from the excavation by measuring the trench before the pipe is installed.

The cross-sectional area will be measured at 25-foot intervals or closer if required to accurately measure the trench. The maximum depth which will be measured for payment must be from the top of the rock formation to the specified subgrade for the pipe embedment material. The maximum width of trench to be considered for payment must be as follows:

1. Below outside top of pipe, maximum width must be the outside diameter of the pipe bell plus 12 inches but not less than 30 inches.
2. From outside top of pipe to top of rock formation, maximum width must be computed based on a 5 on 1 slope vertically for the sides of the trench.

The volume will be computed by the Engineer using the method of average end areas based on measurements of rock actually removed subject to the maximum limits specified.

2.06.05.06 Basis of Payment

Rock excavation will be paid for at the contract price per cubic yard, which price will be payment in full for completing all work as specified herein including removal and disposal of the rock.

If a unit price has not been established in the Proposal, payment to the Contractor will be based on the contract provisions for extra work.

2.06.06 Dewatering

The Contractor must provide and maintain adequate dewatering equipment to remove and dispose of all surface and ground water including water or sewage from exposed sewers or water mains, from all excavations and trenches, or other parts of the work. Each excavation must be kept dry during the preparation of the subgrade and continually thereafter until the structure to be built or the installation of the pipe line is completed to such extent that no damage from hydrostatic pressure, flotation, or other cause will result.

Where work is in soil containing an excessive amount of water, the Contractor must provide, install, and maintain suitable well points or wells connected to manifolds or reliable pumping equipment, or other suitable groundwater dewatering methods, and must so operate the dewatering system to ensure proper construction of the work.

Contractor must submit a groundwater dewatering plan to the Owner. The plan must include the proposed dewatering strategy, including anticipated discharge rate(s) and location(s). Trench underdrain systems, or similar, will require additional information subject to project specific requirements. Discharge of water from groundwater dewatering operations shall be in accordance with all Federal, State and Local requirements, including discharge rate limitations. The Contractor must filter groundwater dewatering discharge and make every effort to prevent sand, sediment, or debris from entering any existing pipeline or conduit which they may use for drainage purposes.

The repair or cleaning of drainage structures made necessary by the Contractor's operations must be performed by and at the expense of the Contractor. Arrangements for discharge of groundwater into any public sewer must be previously approved by the Owner of the receiving sewer. Should the Contractor identify potential contamination in

the water from the groundwater dewatering operation, via visual and/or odor, the Contractor shall immediately notify the Engineer.

Dewatering including the use of stone or gravel for dewatering purposes when required will not be paid for separately but will be included in the contract price for the major items of work.

The Contractor must limit the dewatering operation to the minimum time and depth required for construction. The Contractor will be required to furnish temporary water service and/or provide potable water at the direction of the Engineer to property owners whose wells are affected by the dewatering operations.

2.07 SUBGRADE

The subgrade for pipe and/or structures must be firm, dense, and thoroughly compacted and consolidated, free from mud and muck, and sufficiently stable to remain firm and intact underfoot.

2.07.01 Unstable Foundation

When the soil beneath the normal pipe embedment area is soft or unstable, even with adequate dewatering, or in the opinion of the Engineer cannot support the pipe or utility, further depth must be excavated and refilled to the proposed grade with MDOT Class II granular material (for plastic pipe the material must comply with ASTM D2321) compacted in twelve (12) inch layers to 95% of maximum unit weight in accordance with MDOT procedures, or other approved means must be employed to assure a firm foundation for the utility. The volume of unstable foundation removed and replaced with approved materials for which payment will be allowed will be determined in cubic yards of material, compacted in place, unless otherwise specified on the drawings or in the proposal. Volume will be based on the actual width and depth of material removed and replaced, subject to Engineer review and approval.

Payment for removal, disposal and replacement of unstable foundation will be paid under the contract provisions for extra work, unless specific Proposal items have been provided, in which case, the unit price bid must be payment in full for performing the work as specified. If the soil in the bottom of trench is soft due to excessive amounts of ground water, and/or the Contractor's method of operation, stabilization of the trench bottom must be at the Contractor's expense.

2.07.02 Special Foundations

Where the subgrade at the bottom of the excavation consists of soil which is unstable or yielding to such a degree that, in the opinion of the Engineer, it cannot properly support the pipe or structure, the Contractor must construct such additional foundation or reinforcement of the subgrade as may be specified, such as timber piling, geotextiles, or other means as approved by the Engineer to provide a proper foundation.

The construction of special foundations will be paid for separately based on the contract provisions for extra work, unless specific Proposal items have been provided, in which case the unit price bid must be payment in full for performing the work as specified.

2.08 PIPE EMBEDMENT

2.08.01 General

Pipe embedment must include the furnishing and placing of approved materials as specified or as directed from 4 inches under the outside bottom of the pipe to 12 inches over the outside top of the pipe. Various classes of pipe embedment may be specified or shown on the drawings or details in which case the limits of the various types will also be specified.

Unless otherwise specified or shown on the Drawings, all pipe embedment must be Class B pipe embedment as shown on the Standard details. When the soil in the bottom of the trench at pipe subgrade meets all the requirements for Granular Material Class II as specified in the MDOT 2020 Standard Specifications for Construction, Section 902.07 and in the opinion of the Engineer will provide suitable bedding for the pipe, such soil may be utilized as bedding material and prepared to receive the pipe as specified without undercutting and subsequent replacement.

2.08.02 Flexible Pipe Embedment

Flexible pipe is any pipe having a pipe stiffness of less than 60 psi. as defined under the requirements of ASTM Designation D2412 (this includes all plastic pipe except Composite (Truss) pipe, and may include corrugated metal pipe, ductile iron pipe, and steel pipe, depending on pipe diameter and wall thickness).

Plastic pipe embedment must comply with ASTM D2321. Bedding material must meet the requirements of Section 902.07 of the MDOT 2020 Standard Specifications for Construction for granular materials Class II, modified to 100% passing a 1" sieve must be used. If stone is used for bedding, it must meet the requirements of ASTM D2321 (Table 1 – Embedment Classes for Plastic Pipe) for Class 1A crushed stone. An Engineer approved geotextile filter fabric must wrap around all stone in areas where Class 1A crushed stone pipe embedment is used. Transition zones between crushed stone and sand embedment must be separated by a geotextile fabric.

2.08.03 Special Pipe Embedment

Various types of special pipe embedment may be specified or shown on the Drawings in locations where special conditions require their use. The Contractor must perform all the work of constructing special pipe embedment where specified.

2.08.04 Placing Pipe Embedment Material

Pipe embedment material must be placed in the bottom of the trench and shaped by hand to provide a firm and uniform bearing for the barrel of the pipe with additional shaping to accommodate the bells on bell and spigot pipe. After each pipe has been graded, aligned, and placed in final position on the bedding material and jointing is complete, additional embedment material must be carefully placed, not exceeding 6-inch lifts, and compacted under and around each side of the pipe and over the pipe until it is completely covered by 12 inches of embedment material. Said material must be distributed along both sides of the pipe uniformly and simultaneously to prevent lateral displacement of the pipe. All granular embedment material must be compacted to 95% of maximum unit weight in accordance with MDOT procedures.

All the work of placing pipe embedment must be considered an integral part of installing the pipe and must be completed immediately after the pipe is laid to the correct alignment and grade.

2.08.05 Basis of Payment

All the work of furnishing and/or placing pipe embedment material as specified must be included in the contract items for the proposed work.

When one or more contract items have been provided in the Proposal for special pipe embedment, payment to the Contractor will be based on the prices bid for the respective items. When no specific items have been provided in the Proposal, the cost for completing this work as specified must be included in the major work items except for authorized extra work in which case the contract provisions for extra work must apply.

2.09 BACKFILLING ABOVE PIPE EMBEDMENT

2.09.01 General

All backfill material must be free from cinders, ashes, refuse, sod, organic material, boulders, or rocks larger than 3 inches in diameter, frozen material or other material which in the opinion of the Engineer is unsuitable. The soil excavated from the trenches must be used for backfilling when it is classified as suitable by the Engineer. If all or a portion of the excavated material is classified as unsuitable for backfilling, the Contractor must remove and dispose of the unsuitable material and must furnish and place granular material meeting the requirements of Section 902.07 of the MDOT 2020 Standard Specifications for Construction for Granular Material Class II.

All backfilling and compaction must be performed by the Contractor using methods and equipment approved by the Engineer.

2.09.02 Trenches Requiring Compacted Granular Backfill

Trenches and excavations in the following locations must be backfilled with approved granular material meeting the requirements of Section 902.07 of the MDOT 2020 Standard Specifications for Construction for Granular Material Class II:

- a. Improved areas, including drives, sidewalks, parking areas, around structures, etc.
- b. Within the limits of the roadway (within a 1 on 1 slope beginning two (2) feet from the edge of pavement or back of curb towards the right-of-way line).
- c. Within the limits of future improvements (shown on Drawings).
- d. Within limits specified on Drawings.
- e. All sanitary sewer lateral trenches within the limits of the right-of-way.

All backfill within these areas must be placed in layers not exceeding twelve (12) inches thick and must be compacted to 95% of maximum unit weight in accordance with MDOT procedures. Trenches transverse to undisturbed roadway shall be compacted to 98% of maximum unit weight in accordance with MDOT procedures. Tests for compaction will be made by the Engineer or other representative designated by the Engineer at no cost to the Contractor. When tests indicate a density which is less than that required, the methods or equipment being used must be modified to obtain the density specified, and the section in question must be recompacted until the required density is obtained. The cost of retesting must be borne by the Contractor.

2.09.03 Trenches Not Requiring Compacted Granular Backfill

Where not otherwise specified or directed, backfilling above the pipe embedment must be made with material which is originally excavated, which is suitable. Backfill materials must be consolidated by mechanical equipment working longitudinally in the trench, or by other approved methods, so as to be free of large voids with any excess material mounded over the trench or removed as directed by the Engineer. The trench must be graded to a reasonable uniformity and left in a neat condition.

2.09.04 Basis of Payment

Payment for backfilling including compaction must be made as follows:

When a contract item has been provided in the Proposal for special backfill, payment will be made under this item as specified in Section 2.10 for approved granular material obtained off the site or when no specific item for special backfill has been provided in the Proposal, this work must be included in the major items of work.

2.10 SPECIAL BACKFILL - MEASUREMENT AND PAYMENT

2.10.01 Measurement

When an item has been provided in the Proposal for special backfill, approved granular material obtained off the site which is required by these specifications or authorized by the Engineer must be included in this item. Special backfill will be measured compacted in place. The Contractor must furnish a delivery ticket for each truck load at the time the material is delivered to the project. The delivery ticket must be prepared at least in duplicate, one copy of which must be furnished to the Engineer or their representative, the other copy to be retained in the Contractor's file. No payment will be made for special backfill unless the individual truck delivery tickets are furnished in this manner. The Engineer will use the delivery tickets when calculating the compacted in place quantity.

2.10.02 Payment

The Proposal unit price per cubic yard for special backfill must include payment in full for furnishing, placing, and compacting the special backfill and for disposing of the material excavated from the trench as directed and in accordance with the Drawings and Specifications.

Stone used specifically for dewatering procedures must not be classified as special backfill and no specific payment will be made therefor.

2.11 DISPOSAL OF EXCESS EXCAVATION

All excavated material in excess of that needed for backfill or that material classified as unsuitable by the Engineer must be disposed of by the Contractor. However, the Engineer reserves the right to direct the Contractor to haul all or a portion of the material not required for backfilling to an area designated by the Engineer which is not more than 1,000 feet outside the project and which is reasonably accessible. This work, when directed, must be performed at no additional cost to the Owner.

2.12 LIMITATIONS ON OPERATIONS

The Contractor must at all times conduct their work so that there is a minimum of inconvenience to the residents and businesses in the vicinity of this project. To this end, the Contractor must complete their backfill and remove all debris and unsuitable backfill to a point as close to the actual pipe installation as is practical and keep the area where the pipe construction and backfill has been completed in a neat condition. Open excavations must be protected by signs, lights, barricades, and/or fence at all times when work is not actually taking place at that excavation. The placement of excavated earth along the line of the trench must be controlled by the public's use of the street or right-of-way and must always be confined to approved limits.

Not more than 300 consecutive feet of street must be closed at one time, and vehicular traffic through any street must not be stopped for a period longer than two weeks without the written permission of the Engineer. Not more than one cross street must be closed to vehicular traffic at the same time except by permission of the Engineer. Contractor must maintain access for emergency vehicles at all times.

2.13 SOIL EROSION AND SEDIMENTATION CONTROL

The Contractor must conduct operations in such a manner that all soil is confined within the project limits and prevented from entering storm sewers, water courses, rivers, lakes, reservoirs, or wetlands.

The Contractor must place a filter or barrier composed of straw, stone or other approved material around all catch basins or other inlets to the storm sewer or drainage courses to prevent sedimentation in these structures. After the construction operations are completed, the Contractor must remove these filters and clean all the sediment and debris from the catch basins, ditches or other storm sewer structures.

Soil erosion and sedimentation control measures if indicated on the Drawings are considered as minimum requirements and are not to be considered as complete and all-inclusive. Additional control measures as may be required due to circumstances or conditions at the time of construction or as directed by the Engineer, or the designated Soil Erosion Control agency, must be placed as required to insure conformance with the Part 91 of PA 451 of 1994. Deviations from or additions to the erosion control measures shown on the Drawings must be subject to the approval of the Engineer or enforcing agency.

The Contractor is responsible to have a certified storm water operator and complete all such reports as required by regulatory agencies as it relates to storm water and soil erosion and sedimentation control.

The cost of this work and other control measures which may be required or directed by the Engineer must be included in the major work items to the cost of the project unless specific items have been provided in the proposal.

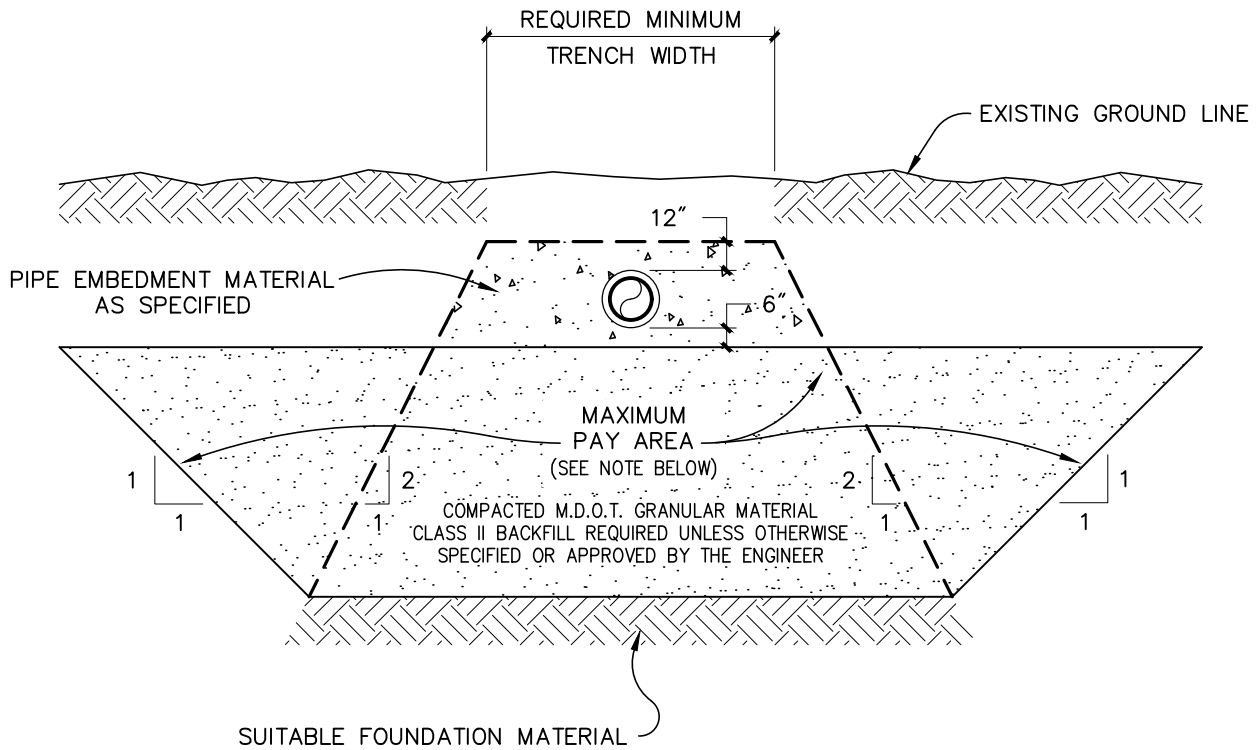

UNSTABLE SOIL REMOVAL FOR UTILITY

NOTE

PAYMENT WILL BE PER CUBIC YARD OF MATERIAL, COMPACTED IN PLACE. VOLUME WILL BE BASED ON THE ACTUAL WIDTH AND DEPTH OF MATERIAL REMOVED AND REPLACED, SUBJECT TO ENGINEER REVIEW AND APPROVAL, BUT SHALL NOT EXCEED THE CROSS-SECTION OF THE DETAIL ABOVE.

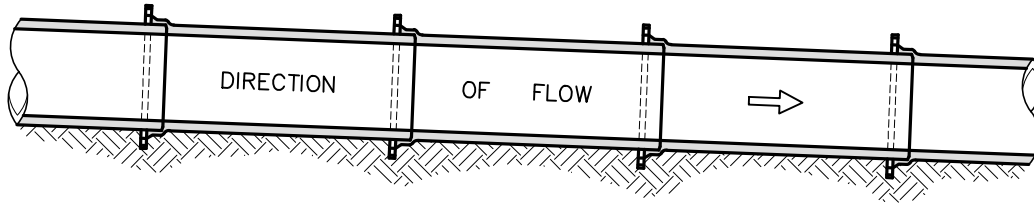

EXCAVATION FOR BELLS

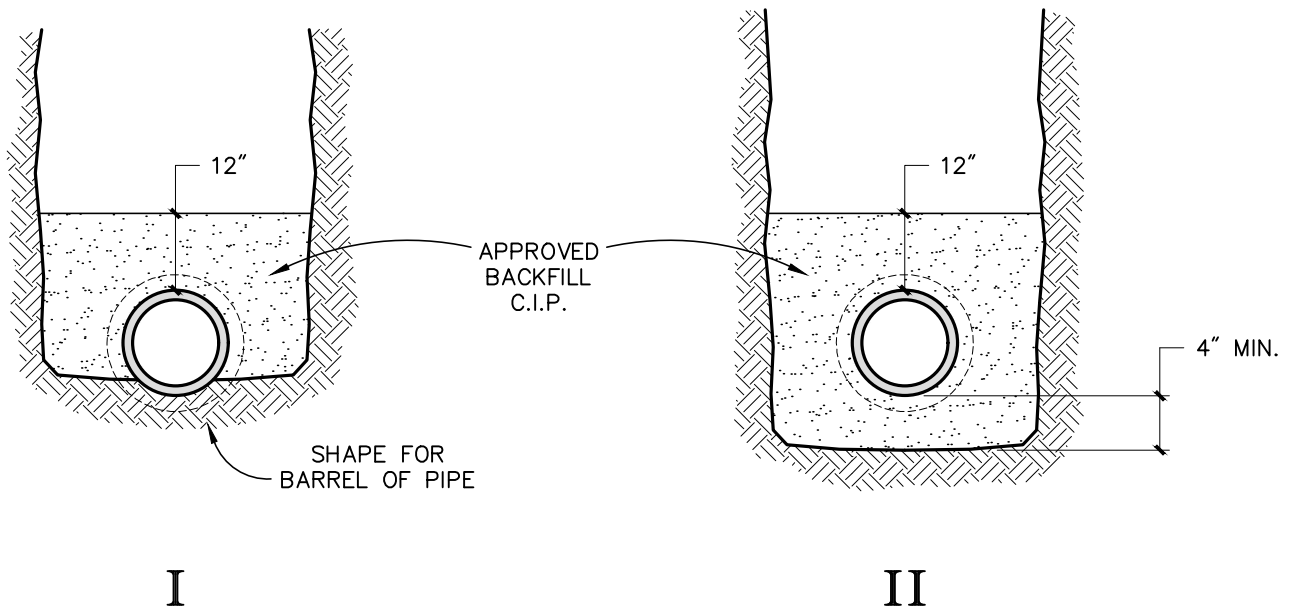

CLASS B PIPE EMBEDMENT

NOTES

1. ALL BACKFILL INDICATED MUST BE COMPACTED TO 95% OF MAXIMUM DENSITY IN ACCORDANCE WITH M.D.O.T. PROCEDURES.
2. METHOD I MUST BE USED IN AREAS OF UNCONSOLIDATED SOILS. (e.g. SAND, GRAVEL)
3. METHOD II MUST BE USED IN AREAS OF CONSOLIDATED SOILS (e.g. CLAY, HARDPAN, ROCK)
4. IF STONE IS USED FOR BEDDING, A NON-WOVEN GEOTEXTILE SEPARATOR (PER MDOT 910) MUST BE PLACED AROUND ALL AREAS WHERE STONE PIPE EMBEDMENT IS USED.
5. TRANSITION ZONES BETWEEN STONE AND SAND EMBEDMENT MUST BE SEPARATED BY A NON-WOVEN GEOTEXTILE SEPARATOR.

SECTION 3

SPECIFICATIONS FOR SURFACE CONSTRUCTION

3.01 DESCRIPTION OF WORK

All areas disturbed by construction operations must be reconstructed per the Drawings. Disturbed areas with no specific reconstruction plans must be restored to the original condition thereof as determined by the Engineer using information from drawings, surveys, and photographs or video when available.

The work must be performed in accordance with the Project Specifications and Drawings, the MDOT 2020 Standard Specifications for Construction, and the following specifications.

3.02 EARTHWORK

All streets, walks, and other improved surfaces disturbed by construction operations must be replaced to uniform lines and grades established by the Engineer. The finish grade line will be established within three (3) inches of the existing ground profile shown on the Drawings unless a proposed grade is shown which indicates otherwise.

The Contractor must perform all grading, compacting, shaping, and related work required to prepare the subgrade per the Prein&Newhof Specifications for Construction Section 2 to the satisfaction of the Engineer.

3.03 SAND SUBBASE

Where specified, imported sand subbase will be placed on all subgrade prior to placement of aggregate base material. Imported sand subbase will be a minimum of twelve (12) inches thick and will be of materials as specified below.

3.03.01 Materials

Imported subbase material must meet the requirements specified in Section 301 of the MDOT 2020 Standard Specifications for Construction. All material must be taken from stockpiles that have been tested within a year by the county road commission, MDOT, or an independent laboratory. Copies of test data must be provided to Engineer prior to placement.

If existing subgrade material is sand meeting MDOT Class II requirements, the contractor may use the existing material for subbase, if approved by the Engineer.

3.03.02 Construction Methods

Placement of imported sand subbase must be in accordance with the applicable portions of Section 301 of the MDOT 2020 Standard Specifications for Construction.

3.03.03 Measurement & Payment

All placement of imported subbase will be measured in cubic yards (compacted in place) and will include all disposal of existing material and grading/shaping of proposed material required. The dimensions of subbase will be as detailed on the Drawings or as described in this specification.

If a pay item is not included in the Bid Proposal, sand subbase work will be considered a part of the major items of work.

3.04 AGGREGATE SURFACING AND SHOULDERS

Aggregate roads, streets, and driveways must be constructed in accordance with the typical section(s) shown on the Drawings or the cross section(s) detailed in the Project Specifications and will consist of a minimum of six (6) inches of aggregate surface course as specified below.

Aggregate shoulders must be constructed in accordance with the typical section(s) shown on the Drawings, the cross section(s) in the Project Specifications, or (in the case of replacement) will match the original width and thickness of the existing shoulder.

3.04.01 Materials

Aggregate surface course must meet the requirements specified in Section 306 of the MDOT 2020 Standard Specifications for Construction. Aggregate shoulder must meet the requirements specified in Section 307 of the MDOT 2020 Standard Specifications for Construction. All surface course and shoulder material must be taken from stockpiles that have been tested within a year by the county road commission, MDOT, or an independent laboratory. Copies of test data must be provided to Engineer prior to placement.

Aggregate surface material that is removed from roadways, driveways, and shoulders must not be reused but must be replaced with an equivalent depth of newly compacted aggregate conforming to MDOT 23A in Section 902 of the MDOT 2020 Standard Specifications for Construction.

3.04.02 Construction Methods

Placement of aggregate surface course and shoulders must be in accordance with the applicable portions of Sections 306 and 307 of the MDOT 2020 Standard Specifications for Construction.

3.04.03 Measurement & Payment

Placement of aggregate surfacing of roads, streets and driveways will be measured in square yards and must include all grading, shaping, and compaction required.

Placement of aggregate shoulders will be measured in square yards and must include all grading, shaping, and compaction required. If there is no Proposal item for shoulder restoration, it should be considered included in the major items of work.

3.05 HOT MIX ASPHALT (HMA) STREETS AND DRIVEWAYS

Hot Mix Asphalt (HMA) streets and driveways must be constructed in accordance the cross section shown on the Drawings, the Project Specifications, and unless otherwise specified, must consist of 165 lbs/syd MDOT 5EL (top) over 220 lbs/syd MDOT 4EL (base) over six (6) inches of compacted 21AA aggregate base.

3.05.01 Materials

Aggregate base for HMA streets must meet the requirements of 21AA in Section 902 of the MDOT 2020 Standard Specifications for Construction. All aggregate material will be taken from stockpiles that have been tested within a year by the county road commission, MDOT, or an independent laboratory. Copies of test data must be provided to Engineer prior to placement.

HMA for base, Leveling, and top courses must be as specified, and must conform to the requirements of Section 501 of the MDOT 2020 Standard Specifications for Construction. Materials for bond coat must be as specified in Section 501 of the MDOT 2020 Standard Specifications for Construction.

3.05.02 Construction Methods

Aggregate base for HMA streets must be placed in accordance with Section 302 of the MDOT 2020 Standard Specifications for Construction.

HMA mixtures must be placed in accordance with the applicable portions of Section 501 of the MDOT 2020 Standard Specifications for Construction. For placement of valley gutters, pavers must be equipped with an extension to the vibrating screed adjustable to fit the typical section shown on the Drawings.

The Contractor must not place the aggregate base course until the subgrade has been approved by the Engineer. The Contractor must not place the first HMA course and each successive HMA course until the underlying aggregate or HMA course has been approved by the Engineer.

3.05.03 Measurement & Payment

Aggregate Base for HMA placement will be measured in square yards per a specified depth.

HMA placement will be measured in tons. Load tickets for HMA clearly stating the mix, date, and other information as required by Section 501 of the MDOT Standard Specifications for Construction are required. If tonnage remains after the paving operation, a weigh back will be required to be supplied from the Contractor to the Engineer.

The cost of HMA bond coat at rate specified in the Drawings will be considered part of the bituminous paving.

Payment for all HMA items must be limited to the measured area multiplied by the proposed application rate plus ten (10%) percent, or the actual tons installed, whichever is less. Any overruns will not be paid for by the Owner.

3.06 HOT MIX ASPHALT (HMA) PATH

HMA path installation must be in accordance with the Prein&Newhof Specifications for Construction Section 9. If the Prein&Newhof Specifications for Construction Section 9 is not included with the Specifications, the Contractor must follow the requirements detailed in section 3.05 of the above specifications and Section 806 of the MDOT 2020 Standard Specifications for Construction.

3.07 PATCHING OF AGGREGATE SURFACE OR HOT MIX ASPHALT (HMA) PAVED AREAS

When the Drawings and Project Specifications do not require that the Contractor replace an entire street, the surface that is disturbed will be replaced as specified herein.

3.07.01 Materials

Hot Mix Asphalt (HMA) patching of paved areas must be constructed in accordance the cross section shown on the Drawings and unless otherwise specified, must consist of 165 lbs/syd MDOT 5EL (top) over 220 lbs/syd MDOT 4EL (base) over six (6) inches of compacted 21AA aggregate base. When existing seal coat pavement is disturbed, a HMA patch must be placed.

Patching of aggregate surface must be replaced with an equivalent depth of newly compacted aggregate conforming to MDOT 23A in Section 902 of the MDOT 2020 Standard Specifications for Construction.

3.07.02 Construction Methods

When an aggregate surface is disturbed by the Contractor's operations, the edges of the existing aggregate surface must be trimmed and must be free of all foreign material before the new aggregate is placed. The aggregate must be placed in layers not to exceed six (6) inches and must be compacted per section 302 of the MDOT Standard Specifications for Construction.

When a HMA surface is disturbed by the Contractor's operations, that surface must be replaced at a thickness equal to the thickness of the existing pavement adjacent to the trench but not less than one and one-half (1-1/2) inches thick. If existing pavement is greater than two (2) inches in thickness, the replacement pavement must be placed in two or more lifts. Aggregate base must be replaced at a thickness equal to the adjacent aggregate base (minimum six inches) as specified for aggregate patches above. After placement of the aggregate base but prior to its final shaping and compaction, the edges of the existing pavement must be trimmed to straight lines a minimum of one (1) foot from the edge of the trench to permit a straight and uniform surface between the existing and new aggregate base. Trimming of the existing pavement must be by saw cutting or other suitable means approved by the Engineer.

All bituminous valley gutter located in disturbed HMA surface areas must be replaced by the Contractor. Replacement of valley gutter in disturbed HMA areas will be considered part of the HMA replacement.

3.07.03 Measurement & Payment

Placement of aggregate base as surface or under HMA will be measured in square yards. HMA patching will be measured in tons. Load tickets clearly stating the mix, date, and other information as required by Section 501 of the MDOT Standard Specifications for Construction are required.

Payment for all HMA items must be limited to the measured area multiplied by the proposed application rate plus ten (10%) percent, or the actual tons installed, whichever is less. Any overruns will not be paid for by the Owner.

3.08 CONCRETE PAVEMENT AND DRIVEWAYS

The Contractor must place all concrete drives, and pavement as detailed on the Drawings.

3.08.01 Materials

Concrete must meet the requirements for Grade 3500 Concrete as specified in Section 1004 of the MDOT 2020 Standard Specifications for Construction. Other materials must meet the requirements of the applicable portions of the MDOT 2020 Standard Specifications for Construction.

The Contractor must provide concrete testing in accordance with the minimum frequency of Quality Control testing in accordance with the MDOT 2020 Standard Specifications for Construction, and the Manual for Michigan Test Methods. Prior to placement of concrete the Contractor must provide a concrete testing plan for review by the Engineer.

3.08.02 Construction Methods

The thickness of the concrete must be the same as the concrete adjacent to the trench but must not be less than six (6) inches.

The alignment and grade and the contour and finish of the surface must be the same as the concrete adjacent to the trench unless otherwise directed by the Engineer.

Pavements and drives must be sawcut at the edges of the trench or removed to existing joints. The depth of the saw cut must not be less than the full depth of the concrete.

The forms and joints and the methods of placing, curing, and protection must be consistent with the MDOT 2020 Standard Specifications for Construction Section 602, standard practice, and the requirements of the latest MDOT Standard Plans.

3.08.03 Measurement & Payment

Concrete pavement and drives will be measured in square feet or square yards of actual concrete surface replaced. Concrete that has been broken by the Contractor outside the limits of the trench will not be considered for payment unless otherwise specified.

3.09 CONCRETE SIDEWALK

Sidewalk installation must be in accordance with the Prein&Newhof Specifications for Construction Section 9. If the Prein&Newhof Specifications for Construction Section 9 is not included with the Specifications, the Contractor must follow the requirements of Section 803, 806, 1001, and 1004 of the MDOT 2020 Standard Specifications for Construction, the latest MDOT Standard Plans, current ADA standards, and the Prein&Newhof Specifications for Construction Section 3.08 for sidewalk installation.

3.10 CONCRETE CURB AND GUTTER

The contractor must install curb and gutter as detailed on the Drawings.

3.10.01 Materials

Concrete for curb and gutter must meet the requirements for Grade 3500 Concrete as specified in Section 1004 of the MDOT 2020 Standard Specifications for

Construction. Other materials must meet the requirements of the applicable portions of the MDOT 2020 Standard Specifications for Construction.

The Contractor must provide concrete testing in accordance with the minimum frequency of Quality Control testing in accordance with the MDOT 2020 Standard Specifications for Construction, and the Manual for Michigan Test Methods. Prior to placement of concrete the Contractor must provide a concrete testing plan for review by the Engineer.

3.10.02 Construction Methods

Concrete curb must be constructed per Section 802 of the 2020 MDOT Standard Specifications for Construction. Unless otherwise specified, MDOT Detail F4 curb will be used in urban applications, and MDOT Detail B2 curb will be used in rural areas in accordance with the latest MDOT Standard Plans.

New curb and gutter must be formed to match existing curb and gutter sections at tie-in points.

3.10.03 Measurement & Payment

Concrete curb and gutter will be considered part of the construction of the utility line unless a specific item is provided in the Proposal for its replacement. If so specified, the concrete curb and gutter will be paid for per foot measured along the face of a header curb or along the flow line of gutter when constructed as part of the curb. All reinforcement, forms, and other item incidental to placement of the curb and gutter is included in payment for curb and gutter. Concrete that has been broken by the Contractor outside the limits of the trench will not be considered for payment unless otherwise specified.

3.11 REPLACEMENT OF LAWN IMPROVEMENTS

3.11.01 Underground Sprinkling and Low-Voltage Equipment

Underground sprinkling lines, valves & heads, water system curb stops and boxes, and underground low voltage wires for dog fences and lawn maintenance are specifically excluded from the pay items. The Contractor must take the necessary precautions to preserve this equipment during construction. Any underground sprinkling and/or low-voltage equipment disturbed by the Contractor must be replaced at the Contractor's expense.

All underground sprinkling and/or low-voltage equipment must be replaced in a timely fashion to minimize damage to the lawn areas. The Contractor will be responsible for any lawn damage caused by delayed replacement of the equipment.

3.11.02 Fences

Fences, which are removed for construction, must be replaced with equal or better type and size. The cost of removing and replacing the fences will be considered part of the major items of work found in the Proposal unless otherwise specified.

3.11.03 Ornamental Shrubbery and Bushes

Ornamental shrubbery and bushes that are removed during construction must be replaced in kind and size in a vigorous growing condition. Replacement costs will be considered part of the major items of work found in the Proposal unless otherwise specified. All shrubs and bushes replaced must be insured by a one-(1) year warranty commencing from the date of installation.

3.12 TURF RESTORATION

All areas of established turf must be replaced as nearly as possible to their original condition.

3.12.01 Topsoil

Topsoil must be placed at a minimum depth of four (4) inches over all areas disturbed by the Contractor's operations. The subgrade must be graded to conform to the adjacent contours and must be approved by the Engineer before placing topsoil. The topsoil must then be placed in accordance with Section 816 of the MDOT 2020 Standard Specifications for Construction.

The soil must be dark, organic natural surface soil, exclusive of muck or peat, suitable for the establishment of grass or other vegetable growth.

3.12.02 Fertilizer

In all disturbed areas, after topsoil has been placed, Class A fertilizer must be installed per Section 816 of the MDOT 2020 Standard Specifications for Construction. Fertilizer must be applied just before the placing of the seed to retain its full benefit before unfavorable weather can cause deterioration.

3.12.03 Seeding

All previously seeded lawn areas must be reseeded with MDOT TUF seed mixture per Section 816 of the MDOT 2020 Standard Specifications for Construction. Temporary seed must be placed for erosion control or temporary soil stabilization of stockpile areas.

Seed mixtures, application rates, and methods must be in accordance with Section 816 of the MDOT 2020 Standard Specifications for Construction.

Seasonal limitations on seeding in Section 816 of the MDOT 2020 Standard Specifications for Construction are waived. The Contractor must repeat the seeding procedure as often as necessary to produce a close stand of weed-free grass.

3.12.04 Mulching

All seeded areas must be mulched immediately following the seeding. Mulching must be applied to all newly seeded areas at a rate of two (2) tons per acre in accordance with the requirements of Section 816 of the MDOT 2020 Standard Specifications for Construction, or as directed by the Engineer. Separate loose straw mulch is prohibited on residential lawn areas.

3.12.05 Hydro Application

All fertilizing, seeding, and mulching must be applied by an approved Hydro seeding and mulching process unless separate applications as heretofore described are approved by the Engineer.

3.12.06 Erosion Control

All erosion control measures must be installed and maintained in accordance with the Soil Erosion and Sedimentation Control plan and permit. Unless otherwise specified, mulch blanket and high velocity blanket must be placed in accordance with Section 816 of the MDOT 2020 Standard Specifications for Construction.

3.12.07 Sod

Sod must be placed only where directed by the Engineer or as noted on the Drawings or Specifications.

All sod must be nursery grown, conforming to MDOT requirements for MDOT TUF seed mixture. Sod must be approved by the Engineer before placing and must be placed in accordance with the requirements of Section 816 of the MDOT 2020 Standard Specifications for Construction. The base on which the sod is to be laid must consist of a minimum of four (4) inches of topsoil placed, watered, and fertilized in the same manner required for seeding.

3.12.08 Measurement & Payment

Turf restoration will be measured in feet along the centerline of the main utility line being constructed. Payment will be made according to the appropriate item for seeding or sod. Topsoil, fertilizer, mulch, and erosion control will be incidental to these items unless specific proposal items are provided. Any area disturbed by the Contractor's operations outside of the limits of the trench must be restored by the Contractor to its original condition but will not be considered for payment.

3.13 SCHEDULING OF RESTORATION WORK

Initial restoration (rough grading, temporary aggregate if necessary, removal of excess excavated material and debris) must be done each day to the extent necessary to allow the movement of local traffic and permit access to all properties for emergency vehicles. Maintenance of streets, drives, sidewalks, etc. are the responsibility of the Contractor (including dust control, grading, stabilization, etc.) until the restoration is complete and has been accepted by the Engineer.

Restoration of each street or section of utility line must follow the construction in a timely fashion to minimize inconvenience to the adjacent property owners and the general public.

3.14 LIMITS FOR MEASUREMENT & PAYMENT FOR SURFACE RESTORATION

All work necessary to return the area of construction operations to its original condition, other than the items listed in the Proposal, will be considered incidental to the construction, and no specific payment will be made therefor.

Payment will be made for the proposal items only. All of the work specified above and indicated on the Drawings will be considered included in the unit prices.

**CITY OF KALAMAZOO
DEPARTMENT OF
PUBLIC SERVICES**

WATER RESOURCES DIVISION



PUBLIC SERVICES DEPARTMENT

WATER RESOURCES DIVISION
415 STOCKBRIDGE AVE.
KALAMAZOO, MICHIGAN 49001-2898
PHONE 269-337-8601
FAX 269-337-8533

**Standard Specifications for
Water Main and Service Installation
2021**



WATER MAIN AND WATER SERVICES

PART 1 GENERAL

1.01 SCOPE

- A. This Section includes furnishing and installing water main systems.
- B. Reconnection of proposed water main and/or water service connections to existing water main and/or water service constructions shall be in conformance with requirements of this Section.
- C. This Section shall include furnishing, excavating, installing, testing, disinfecting, and backfilling all required water main pipe, water service pipes, water main appurtenances, water service, and other work incidental to the water main and/or water service installation unless specifically included under other Items.
- D. This work shall also consist of providing as-constructed plans of the completed work.

1.02 SUBMITTALS

- A. Submittals shall be the responsibility of the Contractor:
 - 1. Shop Drawings for Review:
 - a. Manufacturer's Shop Drawings indicating physical dimensions, and joint details for each size, type, and class of pipe, fittings and specials furnished for the project.
 - 2. Information for the Record:
 - a. Manufacturer's certification indicating that the pipe and joints meet specifications for each production run for each size, type, and class of pipe furnished. The Engineer may request test results to verify certification. Certification documents shall be according to the Source Quality Control of this Section.
 - b. Manufacturer's installation instructions.
 - c. The laboratory shall submit test certifications of pipe ordered tested under "Field Quality Control," of this Section.
 - 3. Engineer may request additional Shop Drawings or Information for the Record as required.
 - 4. **Requests for approved equals must be submitted to the Engineer for review a minimum of two (2) weeks prior to bid.**

1.03 AS CONSTRUCTED RECORD

- A. During construction the contractor shall be required to keep current a set of "as constructed" drawings. Before final payment shall be made, the contractor shall submit for approval to the City of Kalamazoo the complete set of as constructed drawings. Each set of "as constructed" drawings shall be labeled "As Constructed", dated, and contain at a minimum the following information (additional information may be required by the City of Kalamazoo):
 - 1. Note distance between all fittings (Center to Center of Fittings).
 - 2. Note Hydrant to valve, valve to main distances (Center to Center of Fittings).
 - 3. Note the type of bend used, (# of degrees), and the Direction of Bend: (Up or down), (N-S-E-W).

4. Note lengths and locations of restrained joints.
5. Details and profiles of special field situations that relate to the water distribution system shall be included.
6. Dimensional information locating each water distribution system component to real world features, such as property lines, right-of-way lines, and centerlines of roads.
7. On all cul-de-sacs with no center island, measure bends and hydrants to center of cul-de-sac. On all cul-de-sacs with a center island, measure bends and hydrants to center of the roadway.
8. When fittings/hydrants are installed as proposed, please circle the proposed listing.
9. All hydrants shall be noted as to whether or not drip valve plugs were installed.
10. When installing 12 inch or larger valves, (Butterfly Valves), indicate which side of the main the operating nut was placed, as well as gear box style with number of turns to close.
11. The contractor shall complete the service card information including a sketch of the water service installation with dimensions and location of the curb box.
12. Contractor shall GPS all valves, hydrants, fittings, as well a minimum every 3 lengths of pipe for straight runs. DWG files shall be provided to the Engineer upon completion of the project. GPS accuracy shall be subfoot.
13. **All as-built record drawings shall be completed and turned in to the Engineer within 2 weeks from completion of the installation.**

1.04 CONTRACT WORK

- A. Prior to the start of construction, the City of Kalamazoo shall be given the opportunity to provide construction services for any and all portions of the water main construction. The City of Kalamazoo shall submit an estimated cost to perform the work or will issue a bill based on time and material costs. A separate contract with the City of Kalamazoo will be needed for work to be performed by the City of Kalamazoo.
 1. City of Kalamazoo shall perform all water main taps in the water system, unless otherwise directed by the Engineer.
- B. The City of Kalamazoo Department of Public Services must approve the Contractor who will perform water main installation. A reference list of at least five (5) Type 1 supply water main projects completed by the Contractor shall be submitted in support of the Contractor's qualifications. The Department of Public Services maintains a list of Contractors approved for water main installation and can be contacted to receive a current copy of that list.
- C. The Contractor (when hired by the City) or Developer (when the Contractor is hired to perform work by the Developer), shall provide a written statement of warranty (Warranty Bond) for a period of 2 years from the date of **final acceptance** for water main work or **after meter is installed** for water service work. Warranty work shall cover any necessary cost to repair water main or appurtenance leaks and water main or appurtenance leak damage at no cost to the City of Kalamazoo. Final acceptance on all water main and appurtenance work shall not occur until all items have been inspected by the Engineer, passed all required testing, as well as receipt and approval of all as built documents. Additionally, final acceptance on a water service will only be given **once the water meter is installed**.
 1. Water service or water main warranty work shall be completed either a prequalified contractor under the inspection of the City of Kalamazoo, or by City of Kalamazoo field service crews. All warranty work shall be paid for by the Developer or the Contractor.
- D. The Contractor is responsible for field locating all work which has not yet received final acceptance by the City of Kalamazoo. All damage to work that has not received final acceptance is the responsibility of the Contractor.

PART 2 PRODUCTS

All Products shall be supplied new from the manufacturer and certified new from the supplier. No second hand or salvaged material shall be allowed. All products shall be **“Buy American”** unless otherwise specified in this section.

2.01 DUCTILE IRON

A. Ductile Iron (DI) Pipe Specifications:

1. Ductile Iron Pipe shall be manufactured in accordance with American National Standards Institute (ANSI) and American Water Works Association (AWWA) ANSI/AWWA C150/A21.50 and C151/A21.51. Pipe shall be minimum thickness Class 52 pipe. Flanged pipe shall be manufactured in accordance with ANSI/AWWA C 115/A21.15. Pipe through concrete floors or foundations shall be minimum thickness Class 53 pipe.
 - a. Water pipe must be lined with a standard thickness cement mortar lining sealed with a bituminous seal coat in accordance with ANSI/AWWA C104/A21.4, unless otherwise required. The outside of the pipe must be coated with the standard bituminous seal and each length of pipe must be marked with the following information
 - 1) Metal thickness class.
 - 2) Net weight of the pipe without lining.
 - 3) The nominal size.
 - 4) The manufacturer's identifying symbol.
 - b. Underground pipe shall be push on or mechanical joints and above ground pipe shall be flanged joints with gaskets meeting the requirements of ANSI/AWWA C111/A21.11. Nitrile or fluoroelastomer gaskets shall must be used as indicated on the plans and in locations of known or suspected soil or groundwater contamination as necessary. Gaskets provided will be specified based on the type of contamination that is encountered. Each joint shall contain serrated silicon bronze electrical continuity wedges as directed by the Engineer or authorized representative. 4 to 6 inch pipe shall use 2 wedges, 8 to 12 inch pipe shall use 3 wedges, and 16 inch and above shall use 4 wedges.
 - c. Pipe used in conjunction with Horizontal Directional Drilling operations shall be Flex-Ring or TR FLEX joints.

B. Restrained Joints

1. Restrained joints shall meet the requirements of ANSI/AWWA C111/A21.11, and AWWA/ANSI C110/A21.10 or ANSI/AWWA C153/A21.53.
2. Mechanical restrained joints shall be EBAA Iron Megalug series 1100, Romac Romagrip, Ford Series 1400, or approved equal.
 - a. Restraint devices for nominal pipe sizes 4 inch through 54 inch shall consist of multiple gripping wedges incorporated into a follower gland meeting the applicable requirements of ANSI/AWWA C110/A21.10.
 - b. The devices shall have a working pressure rating of 350 psi for 4 to 16 inch, 250 psi for 18 to 48 inch and 200 psi for the 54 inch size. Ratings are for water pressure and must include a minimum safety factor of 2 to 1 in all sizes.

- c. Gland body, wedges and wedge actuating components shall be cast from grade 65-45-12 ductile iron material in accordance with ASTM A536.
 - d. Ductile iron gripping wedges shall be heat treated within a range of 370 to 470 BHN.
 - e. Three (3) test bars shall be incrementally poured per production shift as per Underwriter's Laboratory (U.L.) specifications and ASTM A536. Testing for tensile, yield and elongation shall be done in accordance with ASTM E8.
 - f. Chemical and nodularity tests shall be performed as recommended by the Ductile Iron Society, on a per ladle basis.
 - g. All components shall be manufacture and assembled in the United States.
 - h. Coating for restraint devices shall consist of the following:
 - 1) All wedge assemblies and related parts shall be processed through a phosphate wash, rinse and drying operation prior to coating application. The coating shall consist of a minimum of two coats of liquid thermoset epoxy coating with heat cure to follow each coat.
 - 2) All casting bodies shall be surface pretreated with a phosphate wash, rinse and sealer before drying. The coating shall be electrostatically applied and heat cured. The coating shall be a polyester based powder to provide corrosion, impact and UV resistance.
 - 3) The coating system shall be MEGA-BOND by EBAA Iron, Inc. or approved equal.
3. Push on restrained joint shall be field locking gasket or Flex Ring style as manufactured by US Pipe, McWane, American USA, or approved equal. Field locking or Flex Ring gasket shall match appropriately to the manufacturer of the pipe used.
 4. Use of threaded rods or thrust blocks as a restrained joint shall not be permitted, unless approved by the Engineer.
 5. Restrained flange adapters shall be EBAA Iron Megaflange series 2100 or approved equal.
 - a. Restrained flange adapters shall be made of ductile iron conforming to ASTM A536 and have flange bolt circles that are compatible with ANSI/AWWA C110/A21.10 (125#/Class 150 Bolt Pattern).
 - b. Restraint for flange adapter shall consist of plurality of individual actuated gripping wedges to maximize restraint capability. Torque limiting actuating screws shall be used to insure proper initial set of gripping wedges.
 - c. The flange adapters shall be capable of deflection during assembly or permit lengths of pipe to be field cut to allow a minimum of 0.6 inch gap between the end of the pipe and the mating flange without affecting the integrity of the seal.
 - d. All internal surfaces of the gasket ring (wetted parts) shall be lined with a minimum of 15 mils of fusion bonded epoxy conforming to the applicable requirements of ANSI/AWWA C213. The coating shall meet ANSI/NSF-61. Exterior surfaces of the gasket ring shall be coated with a minimum of 6 mils of fusion bonded epoxy conforming to the applicable requirements of ANSI/AWWA C116/A21.16.
 - e. Restraint Ring coated with MEGA-Bond Restraint Coating System.

C. Ductile Iron Pipe Fittings

1. Fittings, plugs, and gaskets must meet the requirements of ANSI/AWWA C111/A21.11, and AWWA/ANSI C110/A21.10 or ANSI/AWWA C153/A21.53. Cement mortar linings for fittings must meet the requirements of ANSI/AWWA C104/A21.4.
2. Mechanical joints shall be EBAA Iron Megalug series 1100, Romac Romagrip, or approved equal.
3. Restrained flange adapters shall be EBAA Iron Megaflange series 2100 or approved equal.

2.02 Ductile Iron Valves

- A. All underground valves in sizes from 4 inches to 10 inches shall be reduced wall, resilient-seated gate valves for water supply service meeting the requirements of AWWA C 515. Valves shall be American Flow Control Series 2500, Clow model 2638, or EJ Flowmaster Series resilient seated gate valve, Mechanical joint with rubber gaskets (per AWWA/ANSI C 111/A21.11), ductile iron body, stainless steel stem, mechanical joint restraint, and ¾ inch tee head bolts. Valves shall open right (clockwise) and be equipped with standard AWWA operating nut. Nut shall be color coded red. Valves shall have a working pressure rating of 250 psi or greater.
1. In lieu of a mechanical joint restraint, American Flow Control Series 2500 valves may be equipped with ALPHA joints.
- B. All underground valves 12 inches and larger shall be rubber-seated butterfly valves meeting the requirements of AWWA C 504. Valves shall be Pratt Groundhog Butterfly Valves, by Henry Pratt Company, Clow, M&H, or Kennedy model 4500, mechanical joint with rubber gaskets (per AWWA/ANSI C 111/A21.11), ductile iron body, mechanical joint restraint, and ¾ inch tee head bolts. Valves shall open right (clockwise) and be equipped with standard AWWA operating nut. Nut shall be color coded red. Valves shall have a working pressure rating of 250 psi or greater.
- C. All above ground or in pits/vaults valves between 3 inches and 10 inches shall be rubber seated gate valves meeting the requirements of AWWA C515. Valves shall be American Flow Control Series 2500 Resilient Wedge Gate Valve, Clow model 2638, EJ Flowmaster Series, or approved equal with flanged joint with rubber gaskets (per AWWA/ANSI C 111/A21.11), ductile iron body, stainless steel bolts, nuts and washers, stainless steel stem, and be equipped with a hand wheel to operate. Valves shall have a working pressure rating of 150 psi or greater.
- D. All above ground or in pits/vaults valves 12 inches and larger shall be rubber seated butterfly valves meeting the requirements of AWWA C504. Valves shall be by Henry Pratt Company, Clow, M&H, or Kennedy, flanged joint with rubber gaskets (per AWWA/ANSI C 111/A21.11), ductile iron body, and ¾ inch stainless steel bolts, washers and nuts. Valves shall open right (clockwise) and be equipped with standard wheel to operate. Valves shall have a working pressure rating of 150 psi or greater.
- E. All underground valves in sizes from 4 inches to 16 inches used in combination with a tapping saddle shall be reduced wall, resilient-seated gate valves for water supply service meeting the requirements of AWWA C 515. Valves shall be American Flow Control Series 2500, Clow model 2638, EJ Flowmaster Series with one flanged and one mechanical joint ends with rubber gaskets (per AWWA/ANSI C 111/A21.11), ductile iron body, stainless steel stem, mechanical joint restraint, and ¾ inch tee head bolts or approved equal. Valves shall open right (clockwise) and be equipped with standard AWWA operating nut. Nut shall be color coded red. Valves shall have a working pressure rating of 250 psi or greater.

- F. All valves used in conjunction with a fire service line shall be Mueller R-2361-6 Outside Screw and Yoke (O.S.&Y.) with sample tap or approved equal. The stem shall be type 304 stainless steel. Sample tap shall have a 4 ½ inch brass nipple, brass ball valve, and brass plug meeting NSF/ANSI Standard 61 requirements. Sample tap shall be ½ inch for 4 inch and smaller valves and ¾ inch for valves larger than 4 inch.
- G. All valves installed using the insertion style method shall be an all stainless steel body Resilient Wedge Gate Valve designed for permanent use in potable water systems. The design will allow the valve to be installed into an existing pressurized pipeline while maintaining constant pressure and service without system shutdown. No restraining devices, restraining fasteners, or transition gaskets shall be required for the installation or operation of the valve. Valves in sizes 4 inches to 12 inches shall be Hydra-Stop Insta-Valve 250 or approved equal. 16 inch valves shall be Hydra-stop Insta-Valve Plus 250 or approved equal.

2.03 HYDRANTS

- A. All fire hydrants shall be American Flow Control or EJ and shall meet the requirements of AWWA C502. Hydrants shall be provided as complete units including hydrant, hydrant marker, pipe, pipe fittings and valve meeting section 2.01, 2.03 and 2.04 requirements. Hydrants shall be supplied for a bury depth of 5.5 feet. The hydrant barrel shall be painted safety yellow by the manufacturer. Hydrant caps and operating nut shall be painted John Deere green by the manufacturer.
 - 1. American Flow Control hydrants shall be 5 ¼ inch Waterous Pacer Traffic Model WB67-250. Hydrants shall be supplied with a 16 inch upper standpipe length. The Hydrant will come equipped with a bronze upper valve washer. In lieu of a mechanical joint restraint, hydrants may be equipped with ALPHA joints.
 - 2. EJ hydrants shall be WaterMaster Model 5BR250 with snow barrel.
- B. Hydrants shall come equipped with a Carrol Drain. Drain piping shall be made of type 304 stainless steel. External port shall have removable cap for flushing hydrant. Carrol Drain assembly shall be constructed so that it is removable when replacement of assembly is necessary.
- C. Hydrants shall have two 2 ½ inch national standard hose connections, 7.5 threads per inch, OD of threads 3 1/16 inch and one 5 inch integral "STORZ" type nozzle connection. Hose nozzle cap nut, weather shield hydrant operating nut, Storz nozzle cap nut, and Carrol Drain cap nut shall be square 15/16 inch at bottom of nut tapered to 13/16 inch at top (Waterous reference #19). The hydrant mechanism shall be on a non-rising stem opening clockwise. Chains shall not be supplied with the hydrant caps.
- D. Hydrants shall be equipped drip valve, tapped for plug. The drip valve system shall be bronze. Draining system shall be positively activated by the main operating rod, meaning the drip valve will open when the hydrant is closed. Hydrant shall be provided with plug removed.
- E. Hydrants shall have a 6 inch shoe with mechanical joint connections in conformance to ANSI/AWWA C115/21.11.

2.04 FIRE HYDRANT MARKER

- A. The fire hydrant sign shall be installed on a galvanized 2 pound sign post.
- B. The fire hydrant sign shall be aluminum 8 inch x 18 inch (MDOT type III-A) with hydrant symbol and down arrow of a reflective material.
- C. Fire hydrant mounted marker whips shall be 4 feet x 3/8 inch solid pultrusion fiberglass shaft, with seven (7) 6 inch bands of E.G. reflective sheeting of alternating lime green and red color.

Marker shall have a single solid stainless steel spring with aluminum threaded insert, and use Zinc coated bolt & mounting hardware.

2.05 TAPPING SLEEVES

- A. Tapping sleeves for size on size taps or 12 inch and larger sleeves:
1. Model shall be American Flow Control series 2800-C, Tyler Union, Smith-Blair series 665, Romac style SST III, Ford style FTSS, Ford MJTS, or approved equal.
 2. Ductile Iron Tapping Sleeves.
 - a. Sleeves shall be of construction meeting ASTM A536. Side flange seals shall be O-ring type of round cross-sectional shape.
 - b. All sleeves to include the end joint accessories and split glands necessary to assemble sleeve to pipe.
 - c. Sleeve shall be coated with asphaltic varnish in compliance with NSF-61.
 3. Stainless Steel Tapping Sleeves.
 - a. Sleeves shall be 18-8 type 304 Stainless Steel in accordance with AWWA C223.
 - b. Bolts, nuts, and washers shall be 18-8 Type 304 Stainless Steel. Nuts shall be heavy hex, and coated to prevent galling.
- B. Tapping sleeves smaller than 12 inch which are not size on size:
1. Model shall be Smith-Blair series 665, Romac style SST III, Ford style FTSS, or approved equal.
 2. Sleeves shall be 18-8 type 304 Stainless Steel in accordance with AWWA C223.
 3. Bolts, nuts, and washers shall be 18-8 Type 304 Stainless Steel. Nuts shall be heavy hex, and coated to prevent galling.
- C. Line Stop Tapping Sleeves and appurtenances:
1. Model shall be Hydra-Stop HSF 250 Patriot or approved equal
 2. Body shall be type 304 Stainless Steel in accordance with AWWA C223.
 3. Blind Flange shall be Epoxy Coated Carbon Steel or type 304 Stainless Steel.
 4. Bolts, Nuts and Washers shall be type 304 Stainless Steel.
 5. Completion Plug shall be HSF 250 Push and Pin Style, made of reinforced composite polymer.
 6. Completion Plug O-ring shall be BUNA-N Rubber
 7. Completion Plug Pins shall be SAE Grade 8, Zinc coated to prevent corrosion
 8. Completion Pin Plug shall be type 304 Stainless Steel, coated to prevent galling.
 9. Flange O-Ring shall be BUNA-N Rubber.
- D. All gaskets shall be Nitrile in compliance with NSF-61.
- E. No special tools shall be required other than standard socket wrench.
- F. Flange end pilot dimensions to be in compliance with MSS-Sp-60.

2.06 AIR RELEASE VALVES

- A. Air Release Valves – All air release valves shall be manufactured per ANSI/AWWA C512-04. Cla-Val Series 36 Combination Air Valves, or approved equal. The valves shall be of the size listed in the plans.
1. The combination air valve shall combine the operating features of both an air and vacuum valve and an air release valve in one housing. The air and vacuum valve portion shall automatically exhaust large quantities of air during the filling of the pipeline and automatically allow air to reenter the pipeline when the internal pressure of the pipeline approaches a negative value due to column separation, draining of the pipeline, or other emergency. The air release valve portion shall automatically release small amounts of air from the pipeline while it is under pressure.
 2. The inlet and outlet of the valve shall have the same cross section area. The float shall be guided by a stainless steel guide shaft and seat drip tight against a synthetic rubber seal. 4 inch and larger valves shall have dual guided shafts of hexagonal cross section and a protective discharge hood.
 3. The float shall be of all stainless steel construction and capable of withstanding maximum system surge pressure without failure. The body and cover shall be concentrically located and of ductile iron and the valve internal parts shall be stainless steel or Buna-N rubber.
 4. All 1 inch and 2 inch valves shall be NPT. All valves 4 inch and larger shall be flanged.
- B. Vent piping shall be 2 inch diameter, with copper piping below grade and galvanized piping above grade.
- C. Air vent screens shall be black PVC, with NPT threaded to match the size of the connection pipe. Screen shall be one-piece 304 Stainless, mesh size 100. Silver reflective tape shall be placed on the vent pipe.
- D. An air release valve sign shall be installed on a galvanized 2 pound sign post.
- E. The valve sign shall be aluminum 8 inch x 18 inch (MDOT type III-A) with valve symbol and down arrow of a reflective material.

2.07 REPAIR SLEEVES

- A. All repair sleeves shall be certified NSF/ANSI 61-G and 372, and be in accordance with AWWA C230. Sleeves without service tap shall be Smith – Blair model 226, PowerSeal model 3121, or approved equal. Sleeves with service tap shall be Smith – Blair model 238, PowerSeal model 3131, or approved equal.
- B. Sleeves shall use Type 304 Stainless Steel hardware in accordance with ASTM A193/A194. Sleeves shall have conductivity feature.
- C. The repair sleeves shall be of the full circle type designed to repair a fully broken (completely separated) pipe and shall be rated for a working pressure of not less than 150 psi. Repair sleeves 12 inches or under in size will have a single joint.
- D. The length of the sleeves shall not be less than 7 ½ inches. Sleeves shall have no less than three (3) guide bolts of the minimum specified length. Sleeves of longer length shall have an additional guide bolt for every two (2) inches of additional band length.
- E. Each sleeve shall consist of a sealing gasket, a non-magnetic stainless steel band with contact buttons protruding through specially prepared gaskets, clamp lugs, bolts and nuts.
- F. No welding will be permitted in the manufacture of stainless steel repair sleeves except for the addition of the tap to repair sleeve.

- G. The lugs shall not be deformed in the process of attachments to the band during assembly or during removal in the field.
- H. The gasket shall be natural rubber, nitrile or approved equal and shall be of the tapered overlap design to give a pressure tight fit on the pipe surface to form a leak tight, permanent seal when the repair sleeve is installed. The gasket shall have a grid pattern to conform pipe surface irregularities.
- I. The gasket shall have a stainless steel bridge plate flush mounted and securely bonded into the gasket during the molding of the gasket.

2.08 POLYETHYLENE ENCASEMENT

- A. Polyethylene encasement must be manufactured using 8 mil thick virgin polyethylene in accordance with ANSI/AWWA C105/A21.10. Provide the tube size recommended by the manufacturer to protect the pipe and fitting sizes. Provide adhesive tape for the polyethylene tube as recommended by the manufacturer. Tape for repairing damage to the polyethylene must have a life expectancy equal to or greater than the life expectancy of the polyethylene.

2.09 STEEL BLOW-OFF PIPE

- A. Steel pipe shall be hot dipped galvanized meeting the requirements of ASTM A53.

2.10 WATER SERVICES AND APPURTENANCES

A. Copper Service Lines

- 1. Copper pipe shall be used for service lines which are $\frac{3}{4}$ inch, 1 $\frac{1}{4}$ inch and 2-inch. All copper services shall conform to AWWA C800. Water service pipe shall be copper meeting the requirements of ASTM B88, type K.
- 2. All appurtenances on copper service lines shall be flare copper connections. Other connections may be used in lieu of flare copper connections if approved by the Engineer prior to installation.

- B. All water service appurtenances shall meet the requirements of AWWA C800 and be from The Ford Meter Box Company, Inc., A.Y. McDonald Mfg. Co., or as approved by the Engineer. All water service appurtenances for 2 inch and smaller are as follows:

1. $\frac{3}{4}$ inch services:

- a. Corporation Stop $\frac{3}{4}$ inch – FB600-3-NL or AY McDonald 74701B NL (3/4 inch)
- b. Service Saddle – Smith-Blair 311(4 to 12 inch water main), Smith-Blair 313 (16 to 24 inch water main), Romac 101U(4 to 12 inch water main), Romac 202SSU (16 to 24 inch water main), Ford F101(4 to 12 inch water main), or Ford F202(16 to 24 inch water main).
- c. Curb Stop (for use when reducing a 1 $\frac{1}{4}$ inch street service to $\frac{3}{4}$ inch yard service) – Ford B21-555-NL, C18-35-NL, and C28-33-NL
- d. Curb Stop (when using $\frac{3}{4}$ inch street service) – Ford B22-333-NL or AY McDonald 76100 NL ($\frac{3}{4}$ inch)
- e. Brass Fittings – All brass fittings such as tees, elbows, caps, nipples and similar items shall be manufactured in the U.S.A.
- f. Couplings – Ford C22-33-NL or AY McDonald 74758 NL ($\frac{3}{4}$ inch)

2. 1 $\frac{1}{4}$ inch services:

- a. Corporation Stop – Ford FB600-45-NL or AY McDonald 74701B NL (1 x 1 $\frac{1}{4}$ inch)

- b. Service Saddle – Smith-Blair 311(4 to 12 inch water main), Smith-Blair 313 (16 to 24 inch water main), Romac 101U(4 to 12 inch water main), Romac 202SSU (16 to 24 inch water main), Ford F101(4 to 12 inch water main), or Ford F202(16 to 24 inch water main).
 - c. Curb Stop – Ford B22-555-NL or AY McDonald 76100 NL (1 ¼ inch)
 - d. Brass Fittings – All brass fittings such as tees, elbows, caps, nipples and similar items shall be manufactured in the U.S.A.
 - e. Couplings – Ford C22-55-NL or AY McDonald 74758 NL (1 ¼ inch)
3. 2 inch services:
- a. Tapping Valve – Ford B11-777-NL
 - b. Service Saddle – Smith-Blair 313, Romac 202S, or Ford F202
 - c. Brass Fittings – All brass fittings such as tees, elbows, caps, nipples and similar items shall be manufactured in the U.S.A.
 - d. Couplings – Ford C44-77-NL
4. Water meters – All water meters shall be Neptune Water Meters. They shall be supplied and installed by the City of Kalamazoo.
- C. All water service appurtenances larger than 2 inch shall be in accordance with section 2.01.
- D. All multiple meter settings with more than two meters excluding the fire meter shall use a fabricated meter manifold. Fabricated manifold shall be manufactured as follows:
- 1. Water manifold shall be made using 304 Schedule 40 Stainless Steel pipe.
 - 2. Inlet and outlets shall be threaded or welded flange. End cap shall be welded flange with a blind flange for future additions.
- E. Conduit used as sleeves shall be schedule 40 PVC or approved by Engineer.

2.11 METER SETTINGS

- A. Interior meter settings shall use components from the following manufactures.
- 1. 1 inch meter – Ford KV23-454W-NL Angle Valve, Ford C38-44-2-625-NL, Brass Nipple, Apollo 94ALF-105-01A Ball Valve or approved equal
 - 2. 1½ inch and 2 inch meter – Ford FV13-777W-NL Angle Valve, Ford CF35-66NL (1 ½ inch), Ford CF 35-77-NL (2 inch), Brass Nipple, Watts LFFBV-3C Ball valve or approved equal.
 - 3. 3 inch and larger- rubber seated gate valves meeting the requirements of AWWA C515. Valves shall be American Series 2500 Resilient Wedge Gate Valve with hand wheel by American or equal flanged joint with rubber gaskets (per AWWA/ANSI C 111/A21.11), and be equipped with a hand wheel to operate, Hymax 874-56-03008812 (3 inch), 874-56-04010812 (4 inch), 874-56-06016312 (6 inch), or 874-56-08021712 (8 inch) Flange Adaptor, and flange to plain end ductile or type 304 stainless steel spool piece.
- B. Exterior meter settings shall use components from the following manufactures.
- 1. 5/8 inch meter – Ford V81-22-33-NL
 - 2. ¾ inch meter – Ford V83-22-33-NL
 - 3. 1 inch meter – Ford V84-22-55-NL Copper setter

4. 1 ½ inch and 2 inch meter – Watts LFFBV-3C Ball Valve or approved equal. Ford CF-77-1-937-NL Meter Flange, Ford C28-77-NL Coupler, and Brass Nipple.
5. 3 inch and larger – All above ground or in pits/vaults valves 3 inches and larger shall be rubber seated gate valves meeting the requirements of AWWA C515. Valves shall be American Series 2500 Resilient Wedge Gate Valve with hand wheel by American or equal flanged joint with rubber gaskets (per AWWA/ANSI C111/A21.11), and be equipped with a hand wheel to operate, Hymax 874-56-03008812 (3 inch), 874-56-04010812 (4 inch), 874-56-06016312 (6 inch), or 874-56-08021712 (8 inch) Flange Adaptor, and flange to plain end ductile or type 304 stainless steel spool piece.

2.12 FIRE SERVICE APPURTENANCES

- A. All fire service appurtenances shall meet the requirements of AWWA/ANSI C110/A21.10, AWWA C115, and be from the following manufacturers.
 1. Double Check Valve Detector Assembly – Zurn Wilkins Model 350DA or 350ADA with meter setting, AMES Colt LFC300 with meter setting, or approved equal. The City of Kalamazoo will supply the 5/8 inch water meter.
 2. Reduced Pressure Zone Assembly – When using a RPZ in lieu of double check valve for a backflow device, a Zurn Wilkins Model 375DA or 375ADA with meter setting, AMES Colt LFC500 with meter setting, or approved equal shall be required. The City of Kalamazoo will supply the 5/8 inch water meter.

2.13 METER BOXES AND VAULTS

- A. All Meter Boxes, Meter Vaults and components shall be from the following manufactures.
 1. Box – Hancor MP NL1 24 0008 - 24 inch x 48 inch or ADS24X48MP 24 inchx48 inch white corrugated meter pit or Engineer approved equal.
 2. Vault – Precast concrete meter vault shall have a 3 inch minimum wall thickness and size shall be depended on number of meters and meter size. The wall shall have steps that are equally spaced 12 inches apart. Meter vault shop drawings shall be submitted to the Engineer and approved for each installation.
 3. Meter Pit Cover – Vestal 32-497, 32-055, 32-104, and 32-046 or approved equal.
 4. Meter Vault Cover – Ford MC-24HH-MB-T

2.14 VALVE BOXES AND VAULTS

- A. Curb Stop Boxes for 1 ¼ inch Service – Bingham & Taylor Fig. No. 4901-B, 94-F with 2 ½” New Style Flush Fit Cover or approved equal. Cover shall be inscribed with the word “water”.
 1. Curb Stop Box extensions shall be cast iron and manufactured by Bingham & Taylor, capable of being mounted directly to the curb stop box.
- B. Gate Valve Box or 2 inch Service Box – the valve box shall be of adjustable length screw type. The valve box shall be a malleable iron casting conforming to subsection 908.03 of the 2012 Michigan Department of Transportation *Standard Specifications for Construction*. This valve box shall either be a two or three piece screw type and the cover shall be inscribed with the word “water.” Valve box 8550 Series (two piece) or 8560 Series (three piece) manufactured by EJ, 4905 size no. 22 manufactured by Bingham & Taylor, or approved equal.
 1. Gate Valve Box extensions shall be cast iron and manufactured by EJ or Bingham & Taylor, capable of being mounted directly to the gate valve box.
- C. Valve Vaults for Insta-Valves – Valve vaults used in conjunction with Insta-Valves shall be constructed with materials as detailed in WA-8-A of the City of Kalamazoo Standard Plans.

They shall be of the diameter specified and in accordance with subsection 823.02 of the Michigan Department of Transportation *Standard Specifications for Construction* for Gate Wells.

- D. Valve Vaults for Air Release Valves – Valve vaults used in conjunction with Air Release Valves shall be constructed with materials as detailed in the latest WA-4-Series or WA-5-Series of the City of Kalamazoo Standard Plans. They shall be of the diameter specified and in accordance with subsection 823.02 of the Michigan Department of Transportation *Standard Specifications for Construction* for Gate Wells.

2.15 BACKFILL MATERIALS

- A. Use materials meeting the requirements of section 902 of the 2012 Michigan Department of Transportation *Standard Specifications for Construction*.

2.16 BELL JOINT LEAK CLAMP

- A. Bell Joint Leak Clamps shall be Smith-Blair Model 274, Ford Meter Box FBC or MJSC style, or approved equal.
 - 1. The bell spigot ring, section connector, and range spacer shall be ductile iron 80-55-06 in accordance with ASTM 536. Fusion bonded epoxy finish shall meet application methods per AWWA C213. Spigot ring design shall be interlocking to allow ease of installation without interrupting the flow of the pipe. The bolt head pocket shall be integral for one wrench installation.
 - 2. Gasket shall be Nitrile Buna-N per ASTM D2000, and certified to NSF/ANSI 61-G & 372.
 - 3. Restraint Rods and Nuts shall be Type 304 Stainless Steel. Restraint Rod shall have rolled threads, and Nut shall be fluoropolymer coated to prevent galling.
- B. Bell encapsulating couplings shall be Ford Meter Box MJBE style.
 - 1. The coupling shall be designed to fully encapsulate the pipe bell. The coupling shall be of split mechanical joint design with independent end seal and side seal gaskets.
 - 2. All welded components shall be constructed with ASTM A 36 carbon steel.
 - 3. The end seal and side seal gaskets shall be virgin NBR formulated for water service. The gaskets shall not require field trimming, cutting or modification.
 - 4. The end seal compression ring shall be manufactured with ductile iron per ASTM A 526 Grade 65-45-12 or ASTM A 36 carbon steel.
 - 5. The coupling shall be coated to an average of 12 mills thickness with a fusion-bonded epoxy that is NSF 61 listed and meeting application methods of AWWA C213.

2.17 COUPLINGS

- A. Wide range couplings shall be Romac Alpha or approved equal.
 - 1. All cast components shall be ductile iron, meeting or exceeding ASTM A 536, grade 65-45-12
 - 2. Grippers shall be ductile iron, meeting or exceeding ASTM A 536, grade 65-45-12.
 - 3. Gaskets shall be SBR compounded for water service per ASTM D2000 and meet NSF61 classification.
 - 4. Bolts and nuts shall be 304 stainless steel.
 - 5. Body shall be epoxy coated, and NSF61 Certified.

2.18 STRUCTURE CASTINGS

- A. All 24 inch structure covers shall be a malleable iron casting conforming to subsection 908.03 of the 2012 Michigan Department of Transportation *Standard Specifications for Construction*. The structure cover shall be series 1040 manufactured by EJ, inscribed with the word "Water".

2.19 STEEL CASING PIPE AND APPURTENANCES

- A. Steel casing pipe shall meet the requirements in accordance with subsection 909.05.D of the 2012 Michigan Department of Transportation *Standard Specifications for Construction* with the exceptions listed below:

- 1. For steel casing pipe jacked under a railroad, replace in its entirety the entry for 30 inch nominal size listed in Table 909-18 with the following:

Nominal OD and Wall Thickness in Inches Jacked in Place Steel Pipe

Nominal Size	Nominal Outside Diameter	Wall Thickness
30	30.000	0.406(a)
<ul style="list-style-type: none"> a. Coated or cathodically protected (0.469 inch minimum if uncoated and unprotected) 		

- 2. Steel casing must have a minimum yield strength of 35,000 pounds per square inch (psi) and be in accordance with ASTM A53, Type E or S, Grade A or B and be designed for Cooper E80 loading requirements. In all cases, the allowable jacking strength capacity of the casing pipe shall be capable of withstanding the maximum jacking forces imposed by the operation.

- B. Stainless steel band spacer shall be Advance Products & Systems model SSIM or approved equal. The bands shall be constructed of circular stainless steel bands, which bolt together forming a shell around the carrier pipe. The spacers shall be designed with runners to support the carrier within the casing and maintain a minimum clearance of 1.00 inches between the casing inside diameter (ID) and the spacer outside diameter (OD). The spacers shall contain four modular runners – two on each half. Stainless steel bolts, nuts and washers shall be supplied with the casing spacers.

The band shall be manufacture of 8 inch wide 14-guage T-304 stainless steel. Abrasion resistant runners, having a minimum length of 7 inches and a minimum width of 1 inch, shall be attached to each band to minimize friction between the casing pipe and the carrier pipe as it is installed. Runner material shall be of glass filled polymer with compression strength of 33,000 psi, flexural strength of 40,000 psi, and tensile strength of 27,000 psi. The ends of thall runners shall be beveled to facilitate installation over rough weld beads or the welded ends of misaligned or deformed casing pipe.

Interior surfaces of the circular stainless steel band shall be lined with PVC, or EPDM alternate, having a minimum thickness of .090 inches with a harness of Durometer "A" 85-90.

Recommended position of the spacers is one placed not more than one foot from each end of the casing and pipe joint. Subsequent spacers shall be placed every 6-8 feet apart thereafter.

- C. Casing end seal shall be Advance Products & Systems model AC or approved equal. Pull-on casing end seals shall be manufactured of 1/8 inch thick neoprene rubber assuring excellent chemical resistance and resiliency. End seals must be effectively used in the temperature range of -20 degrees to 190 degrees Fahrenheit. End seals shall include ½ inch wide T304 stainless steel bandings with 100% nonmagnetic worm gear mechanism. End seals shall be seamless, have vulcanized edges, and can be pulled on at the time of construction.

PART 3 EXECUTION

3.01 CONSTRUCTION

- A. The plans show the locations of existing utilities in accordance with available data. If the work requires precise information on the location of existing utilities, the Contractor will expose utilities shown on the plans to determine the actual locations.

Do not disturb or cut into existing in-service water mains. If the operation of valves in existing water mains is required, notify the City of Kalamazoo a minimum of 3 working days in advance. Coordinate scheduling of water main connections with the City of Kalamazoo. Secure the Engineer's or authorized representative's approval of the schedule before beginning the work.

The City of Kalamazoo will open or close in service valves and provide on-site inspections for all water main and water service installations. The City of Kalamazoo will perform this work for an estimated time and material charge. The cost of opening and closing valves and on-site inspection will need a separate contract with the City of Kalamazoo prior to start of work. This does not apply to work being contracted by the City of Kalamazoo.

Minimize the out of service time for existing water mains. Make connections at night, on Sundays, or on holidays, as conditions require or as approved by the City of Kalamazoo. Minimize interference with the water supply if abandoning existing water mains and incorporating new water mains into the water system.

No trees or permanent structures shall be placed within 10 feet of the centerline of the water main or service line.

3.02 TRENCH EXCAVATION

- A. Excavate water main trenches to the lines and grades shown on the plans in accordance with modifications approved by the Engineer, or authorized representative, or to meet or bypass existing utility structures. Excavate trenches to the depths shown on the plans to provide 5 feet of cover from top of water main to the final grade. Excavate trenches to the widths shown on Michigan Department of Transportation Standard Plan R-83 Series.
- B. Excavate the bottom of the trench to the required grade to allow 6 inches of bedding for the pipe. Do not block under the pipe.
- C. Maintain trenches for water mains free of ground or surface water by pumping or as otherwise approved by the Engineer or authorized representative
- D. Install, and later remove, temporary timber bracing, as required to prevent movement or damage to new or existing water mains or adjacent utilities.
- E. During backfilling, carefully remove supports for sheeted and braced excavations to prevent earth banks or adjacent streets from collapsing.
- F. The Contractor may leave sheeting and bracing in place during backfilling and remove after completing backfilling operations. The Contractor may leave sheeting and bracing in place, if approved by the Engineer and the Contractor cuts it off 5 feet below the ground surface.

3.03 DISPOSAL

- A. Dispose of waste material as specified in section 205 of the 2012 Michigan Department of Transportation *Standard Specifications for Construction*.

3.04 LAYING OF THE PIPE

- A. Install the pipe joint restraint system in accordance with the manufacturer's recommendations, or as directed by the Engineer. Assemble the pipe in the trench. If deflections at joints are required by changes in grade, alignment, or to plumb valve stems, ensure deflections of bell and spigot joints and mechanical fitting joints do not exceed three-quarters of the maximum deflection recommended by the joint manufacturer or that allowed by AWWA C600, whichever is less. Do not store or leave tools or other objects in the pipe.
- B. Provide restrained joints as indicated on the plans. No tie rods or thrust blocks shall be allowed unless approved by the Engineer or authorized representative.
- C. Proper actuation of the gripping wedges of the mechanical joint restraint shall be ensured with torque limiting twist off nuts.
- D. The Contractor shall provide a written statement of warranty (Warranty Bond) for a period of 2 years from the date of **final acceptance (after meter is installed)**. Warranty work shall cover any necessary cost to repair water main or appurtenance leaks and water main or appurtenance leak damage at no cost to the City of Kalamazoo. Final acceptance will only be given **once the water service meter is installed**.
- E. Pipe shall be laid with bell ends facing the direction of laying, unless otherwise directed by the Engineer or authorized representative. When pipe is laid on a grade of 10 percent or greater, the laying shall start at the bottom and proceed upward with the bell ends of the pipe upgrade.
- F. Install silicon bronze wedges between all push-on joint pipes to allow for underground location and thawing of pipeline. 4 to 6 inch pipe shall use 2 wedges, 8 to 12 inch pipe shall use 3 wedges, and 16 inch and above shall use 4 wedges at each pipe joint.
- G. Pipe shall be restrained in accordance with Table 3.1.

Table 3.1 Pipe Thrust Restraint Table

NON-POLYWRAPPED PIPE								
Pipe Size (Inches)	90° Bend	45° Bend	22.5° Bend	11.25° Bend	Tee*	Reducer (One Size)	Reducer (Two Sizes)	Dead End
4	44	18	9	5	42	-	-	42
6	62	26	13	7	59	31	-	59
8	82	34	17	9	78	33	56	78
10	100	42	20	10	94	32	58	94
12	119	50	24	12	110	33	59	110
16	157	65	32	16	143	61	85	143
20	195	81	39	20	173	61	109	173
24	233	97	47	23	204	61	111	204
30	288	120	58	29	246	86	134	246
POLYWRAPPED PIPE								
Pipe Size (Inches)	90° Bend	45° Bend	22.5° Bend	11.25° Bend	Tee*	Reducer (One Size)	Reducer (Two Sizes)	Dead End
4	62	26	13	7	60	-	-	60
6	88	37	18	9	84	44	-	84
8	117	49	24	12	111	47	80	111
10	142	59	29	14	133	45	82	133
12	170	71	34	17	158	47	84	158
16	224	93	45	23	203	87	121	203
20	278	116	56	28	247	87	155	247
24	332	138	66	33	291	87	159	291
30	411	171	82	41	351	123	191	351
* Length of restraint for branch; use the size of the branch Consult Engineer for scenarios not included in table.								

3.05 INSTALLATION OF PIPE INVOLVING HORIZONTAL DIRECTIONAL DRILLING

- A. Horizontal direction drilling (HDD) is a method of trenchless construction using a surface launched steerable drill tool controlled from a mobile drilling frame, and includes a field power unit, drilling fluid mixing system, and mobile spoils extraction system. The work generally consists of three phases:
 1. Drilling a pilot hole from the surface or pit at a starting point to an exit pit at the surface beyond the obstacle or area that is to be avoided.
 2. Reaming the pilot hole to make it large enough for the pipeline to be installed.
 3. Pipeline is pulled into place. During the pipe pulling operation, drilling fluid (a bentonite, water, and polymer solution) is injected to stabilize the hole, remove cuttings, and lubricate the pipe.
- B. Coordination

1. Drilling operations shall not interfere with, interrupt or endanger surface features or surface activities.
2. When rock stratum, boulders, underground obstructions, or other soil conditions that impede the progress of drilling operation are encountered, the Contractor and Engineer shall review the situation and jointly determine the feasibility of continuing drilling operations, making adjustments or switching to an alternative construction method.
3. The contractor shall familiarize themselves with the geologic characterization of the soil stratum at the proposed drilling path. The Contractor shall be responsible for informing the Engineer of any changes that are required in the directional drilling procedure due to geologic conditions.
4. Launching and recovery pits shall be as small as practical. Dewatering of pits and excavations shall be done in accordance with the City of Kalamazoo Standard Specifications. When groundwater is encountered, the Contractor shall provide a dewatering system of sufficient capacity to keep any excavation free from water until the backfill operation is in progress. Dewatering shall be performed in a manner that removal of soil particles is held to a minimum. Water from the dewatering system shall be desilted before discharge. Methods of dewatering and desilting, including all costs shall be the Contractor's responsibility and are included in the Horizontal Directional Drilling Water Main pay item.
5. Utilities shown on the plans are approximate. In areas where there is a potential conflict, the Contractor shall dig up and verify the locations and elevations of the utilities at no additional expense to the City. The Contractor shall assume full responsibility for the protection fall utilities, structures and their foundations which may be affected by the work.
6. Before beginning the drilling process, the Engineer shall stake the proposed drill path.

C. Drill Path Survey

1. The Drill path shall be walked in the presence of the Engineer and the Contractor with the guidance system that shall be used for each segment of drill path. The contractor shall locate and record any surface and subsurface magnetic variations or abnormalities and all points of interference, as well as verifying all utility locations and corresponding utility maps. Should any discrepancies arise between utility maps, field locations and guidance system findings, the Contractor shall clarify all discrepancies prior to beginning drilling operations. The drill path survey shall be performed no earlier than two days prior to commencing drilling operations. Provide the Engineer 48-hour notice of drill path survey.

D. Equipment

1. The drilling equipment shall be capable of placing the pipe within the planned line and grade without inverted slopes.
2. The drilling equipment shall be capable of pulling product pipe from either the downstream or upstream pit locations. The equipment must be adequately sized for the application.
3. The guide system shall have the capability of measuring inclination, roll and azimuth. The guidance system shall have an independent means to ensure the accuracy of the installation. The Contractor shall demonstrate a viable method to eliminate accumulated error due to the inclinometer (pitch or accelerometer). The guidance

system shall be capable of generating a plot of borehole survey for the purpose of a record drawing. The guidance system shall meet the following specifications:

Inclination:	Accuracy	+0.05
	Range	+90
	Repeatability	+0.02
Roll:	Accuracy	+0.05
	Range	+90
Azimuth	Accuracy	+0.05
	Range	+90

4. Equipment setup requirements at the launch and recover locations shall be determined by the Contractor in accordance with the Plans and shall be submitted to the Engineer prior to commencement of drilling operations.

E. Pilot Hole Drilling

1. The entry angle of the pilot hole and the drilling process shall maintain a curvature that does not exceed the allowable bending radii of the carrier pipe per the manufacturer's recommendations.

F. The contractor shall follow the pipeline alignment as shown on the Plans, within the specification requirements. The location and depth of the drill head in relation to the profile and centerline of the alignment shall be determined at a maximum of ten-foot intervals. Acceptable tolerance shall be 0.5 feet variation from the centerline of the pipe in both vertical and horizontal directions (1-foot tolerance window).

G. In the event of difficulties at any time during drilling operation requiring the complete withdrawal from the tunnel, the Contractor shall either be allowed to withdraw and abandon the tunnel and begin a second attempt at a different location. The alternate locations shall be approved by the Engineer before the Contractor withdraws.

H. Access pits shall be at the beginning and end segments shown on the Plans. Intermittent pits shall be approved by the Engineer prior to proceeding with drilling operations. No intermittent access pits shall be allowed in Railroad Right of Ways.

I. Installing the Carrier Pipe:

1. After the pilot hole is completed, the Contractor shall install a swivel to the reamer and commence pullback operations.
2. Reaming diameter shall not exceed 1.5 times the diameter of the carrier pipe being installed.
3. The carrier pipe being pulled into the tunnel shall be protected and supported so that it moves freely and is not damaged by stones and debris on the ground during installation.
4. Pullback forces shall not exceed the allowable forces for the carrier pipe.

J. The Contractor shall allow sufficient lengths of carrier pipe to extend past the termination point to allow connections to adjacent pipe sections, tees, or fittings. Pulled pipe shall be allowed 24 hours of stabilization prior to making tie-ins. The length of extra carrier pipe shall be at the Contractor's discretion.

K. Field Inspection

1. All pipe sections, specials, and jointing materials shall be carefully examined for defects and no piece shall be laid that is known to be defective. Any defective piece discovered installed shall be removed and replaced with a sound one in a manner satisfactory to the Engineer at the Contractor's expense.
2. Defective material shall be marked with an "X" in pink paint and shall be removed from the job site.

L. Drilling Fluid Containment and Disposal Requirements

1. The contractor shall contain, handle, and dispose of drilling fluids in accordance with the following requirements:
 1. All drilling fluid and fluid additives shall be disclosed, and Material Safety Data Sheets (MSDS) shall be provided to the permit agency and the Engineer upon request.
 2. Excess drilling fluid shall be confined in a containment pit at the entry and exit location until recycled or removed from the site.
 3. Precautions shall be taken to ensure that drilling fluid does not enter the roadways, streams, municipal storm or sanitary sewer lines, and/or any other drainage system or body of water.
 4. When installing below railroads, vents shall be installed on either side of the railroad tracks to direct any excess drilling fluid to a containment area and to prevent unintended surfacing of drilling fluid within the Railroad Right of Way.
 5. Unintended surfacing of drilling fluid shall be contained at the point of discharge and recycled or removed from the site.
 6. Drilling fluids that are not recycled and reused shall be removed from the site and disposed at an approved disposal site.
 7. Drilling fluids shall be completely removed from the construction site prior to backfilling or restoring the site.

3.06 ABANDONING WATER MAINS

- A. Remove and dispose of abandoned pipe, gate boxes, or other appurtenances, as necessary for placement of a new water main at no additional cost to the City of Kalamazoo. Remove portions of gate boxes to at least 3 feet below the pavement surface under the road, and to at least 12 inches below the planned grade outside the road. If the Engineer determines abandoned mains may remain in place, cap the end of pipe with cap and megalug or as directed by the Engineer or authorized representative. If shown on the plans or directed by the Engineer or authorized representative, fill abandoned water mains with non-structural flowable fill.

3.07 VALVES

- A. Prior to installation, all valves shall be fully operated open and close to verify its functionality and number of turns. Set and join valves to the water mains as required for cleaning, laying, and jointing the required type of pipe, as shown on the plans. Install valves as required by the contract, or as approved by the Engineer. Place the valve stems plumb. Install valves to not bear on the pipe. Install anchor coupling with valves installed on tees or crosses, with swivel gland located on the valve side of the anchor coupling.
- B. When installing 12 inch and larger valves (Butterfly Valves), the operating nut shall be located on the side of the valve furthest from the centerline of the roadway, unless otherwise directed by the Engineer.

3.08 LIVE TAPS TO IN SERVICE WATER MAINS

- A. Prior to tapping of the main contractor shall disinfect all pipe, appurtenances, tapping machine with chlorinated water.
- B. Contractor shall install all necessary tapping appurtenances according to manufacturer's recommendation.
- C. Contractor shall use equipment which allows the tapping machine to rinse out metal shavings and tap water main per manufacturer's recommendations. No tap 4 inches or larger shall be allowed within 4 feet from any joint, fitting, or exiting tap regardless of location of tap. 1 ¼ inch taps located within 10 feet of previous tap shall be offset 15 degrees.
- D. Once tapping is complete Contractor shall disinfect all exposed water main and appurtenances with chlorinated water.

3.09 VALVE BOXES.

- A. Provide valve boxes that do not transmit shock or stress to the valve. Place valve boxes plumb over the operating nut of the valve, with the box cover flush with the pavement, or as approved by the Engineer or authorized representative. Provide firm support for valve boxes.
- B. Valve boxes shall be installed, centered and plumbed over the operating nut of the gate valve. The area around the valve box shall be back-filled with Granular Material Class II placed in layers not to exceed 12 inches, and thoroughly compacted to the required density. The Contractor shall take due care to prevent the box from shifting during backfilling operations. The tops of the valve boxes shall be flush with the established pavement or ground surface.

3.10 ADJUSTING OR RECONSTRUCTING WATER SHUT OFFS OR VALVE BOXES

- A. Adjust and reconstruct water shutoffs or valve boxes to the final grade or as approved by the Engineer or authorized representative. Replace shutoff or gate box materials damaged during adjustment or reconstruction, as determined by the Engineer, or authorized representative, at no additional cost to the City of Kalamazoo.

3.11 WATER SERVICES

- A. Water Services shall not be connected to the water main until approved by the Engineer or authorized representative.
 - 1. The standard size for all new services shall be 1 ¼ inch. The property owner/developer may request a larger size if needed.
 - 2. ¾ inch service materials may only be used when performing repairs or partial replacements of an existing ¾ inch service, or when replacing the yard service of a ¾ inch service. When replacing a complete street side service of a ¾ inch service, a new 1 ¼ inch tap will be completed, new 1 ¼ inch street service line installed, and reduced down at the curb shut off per section 2.10.
- B. Tap water main per section 3.08.
- C. When more than two meters excluding the fire meter are required to be set on a single service line, a fabricated meter manifold shall be installed.
- D. Water Services 2 inch and Smaller
 - 1. Construct services from the distribution main to the water meter. Lay services in a straight line perpendicular to the water main unless approved by the Engineer or authorized representative. Construct service with a continuous piece of copper from the corporation stop to the curb stop and curb stop to the water meter unless

approved by the Engineer or authorized representative. Services over 300 feet will require an exterior meter setting (meter pit).

2. All couplings shall be located as close to the water main as possible, but outside roadway unless approved by the Engineer.
3. The use of thread sealant shall be not be allowed on flare fittings.
4. No splices shall be allowed for 1 ¼ inch or smaller yard services 90 feet and shorter in length.
5. Tap and curb shut off locations shall be no closer than 5 feet to edge of driveways. If a service is required to be abandoned due to improper location, service shall be fully abandoned at the water main tap location and new service installed the developer's expense. Corporation stop shall be shut off, copper piping removed, and copper disc installed on the corporation stop.
6. If finish grade changes from plan grade after installation of service, curb shutoff shall be adjusted to 5 foot bury depth at the developer's expense.
7. When the street service is installed separately from the yard service a copper disk shall be installed on the yard side of the curb valve per the manufactures recommendations as approved by the Engineer or authorized representative.

E. Water Services Greater than 2 inch

1. For services entering a building with no basement, install the stand pipe flange 12 inch from the finished floor elevation and 6 to 12 inches away from any walls. Install the flange pipe so two bolt holes are parallel from each wall (two hole). For services entering a building with a basement or into a concrete vault, install the stand pipe flange 6 to 12 inches off the wall. Install the flange pipe so that two bolt holes are parallel to the floor, normal to the wall. For all services entering a building, the service line shall be located in room located on an outside wall of the building, with enough room to maintain the service.
2. Contractor shall complete installation of service prior to pressure testing and disinfection. The Contractor shall hydrostatic test the complete fire service from the nearest outside valve to first valve (OS&Y) before installing the fire check valve per section 3.22. Service shall be cleaned, flushed and tested per section 3.23. No connection shall be made to these services until after pressure test is complete and consecutive negative bacterial test results have been received in accordance with sections 3.22 and 3.23 of this specification, and the water main approved by the Engineer or authorized representative.
3. No adapter flange or grooved pipe joint shall be used on any portion of the service to be maintained by the City of Kalamazoo, with the exception of the meter side of an OS&Y fire service valve.
4. For service lines with multiple meter settings, a valve the same size as the incoming service line shall be installed prior to the tee or manifold. If one of the meter settings is for a fire service, the valve shall be an OS&Y valve in accordance with section 2.02.F.

F. Construct the service pipe with at least 5 feet of cover, unless Engineer or authorized representative requires additional depth.

G. Make all service connections, and transfers. Maintain and protect, at no additional cost, existing service connections requiring transfer, but not shown on the plans, until reconnection or disposal.

- H. If relocating a portion of water service, shut down the water service by method approved by the Engineer or authorized representative.
- I. Service lines entry points into the structure shall be sealed with hydraulic cement or mastic putty and oakum to prevent groundwater infiltration. For ductile iron pipe services, link seals should be used as the preferred method.
- J. FIRE SERVICES
 - 1. The Contractor shall notify the Engineer or authorized representative a minimum of 3 working days prior to flushing the fire service or testing the fire system capacity.
 - 2. All fire services shall have an OS&Y valve meeting the requirements of 2.02.F installed. The sample tap on the OS&Y Valve shall be installed on the downstream side of the valve.
- K. INTERIOR METER SETTINGS (PREFERED)
 - 1. Interior valve and meter inlet connection shall be installed by the Contractor in accordance with the Engineer, or authorized representative's recommendations and final approval.
 - 2. The meter setting shall be located in a heated portion of the building. The meter setting shall not be located in a crawl space, above electrical appliance, or near an electrical panel. A clear and unobstructed access to the meter of not less than 24 inches by 24 inches shall be provided.
 - a. 1 ¼ meter settings must be placed in basements. Meter setting shall be placed in the front of the building facing the street or within three feet of the front on the side unless otherwise approved by the Engineer or authorized representative. Water Services shall not be placed under footings. If service enters house under the porch and the porch footing extends below water service, a 2 inch PVC sleeve will be required.
 - b. A ½ inch schedule 40 PVC conduit, or larger, shall be installed from the meter setting to the remote reading point. There shall be no more than 75 feet of conduit between pull boxes. There shall be no more than four (4) 90-degree bends between pull boxes. All pull boxes must be installed no more than 96 inches above the floor. Pull boxes shall not be installed in attics or crawl spaces.
 - 3. The City of Kalamazoo will install the meter, readout, readout wire, copper ground wire, outlet meter connection and valve.
- L. EXTERIOR METER SETTINGS
 - 1. Exterior meter settings shall be installed by the Contractor according to the Engineer's or authorized representative's recommendations, and in accordance with City of Kalamazoo Standard Plans. Meter settings will be required for services greater than 300 feet, slab on grade, crawl spaces, where minimum 5 foot bury depth cannot be maintained, and other reasons. Contractor shall verify proper meter location with the Engineer prior to construction.
 - 2. Meter boxes or vaults shall not be installed in any street, alley, parking area, driveway, or sidewalk. Major landscaping (shrubs, boulders, etc.) and structures (retaining walls, fences, buildings, etc.) shall not be placed within seven and a half (7.5) feet or trees shall not be planted within ten (10) feet of any meter box or vault, unless otherwise directed by the Engineer.

3. The ground surrounding meter boxes, pits and vaults shall slope away from the lid at a minimum grade of 2%
4. No plumbing or electrical connections will be allowed inside the meter box or vault, unless otherwise directed by the Engineer.
5. All tees, connections, and couplings shall be a minimum of five (5) feet downstream from the meter box or vault wall on the outlet side. Tees and connections shall not be installed between the curb stop and the meter setter or copper horn.
6. Meters shall be installed by the City of Kalamazoo upon inspection and acceptance of the meter setting.
7. Meter boxes shall be used for all 1 inch exterior meter settings. The Contractor shall install meter boxes to horizontal location and to final grade as determined by grade stakes. Meter boxes shall be installed 5 feet outside the right of way in private property. All work shall be in accordance with the current WS-8 of the City of Kalamazoo Standard Plans.
8. For services 1 ¼ inch and smaller, curb shutoffs shall be located in the right of way, centered in the curb lawn area, or as directed by the Engineer.
9. The Contractor shall install meter vaults for 1 ½ inch and larger meter settings.
10. Meters shall be installed by the City of Kalamazoo upon inspection and acceptance of the meter setting.

3.12 WATER MAINS, CUT AND PLUG

- A. All work related to water main, cut and plug shall be in accordance with section 3.06.A. If the plans show cutting and plugging water mains, arrange for the City of Kalamazoo to shut down the main. Remove the section of pipe and plug the water main as shown on the plans or as approved by the Engineer or authorized representative. Construct the required restraint as directed by the Engineer or authorized representative.

3.13 FIRE HYDRANTS

- A. Set fire hydrants at the locations shown on the plans and in accordance with City of Kalamazoo standard plans and manufacturer's recommendations or as coordinated with the City of Kalamazoo. When installed, the hydrant shall be located on the side of the water main furthest from the centerline of the roadway, unless otherwise directed by the Engineer. Equip the hydrant with auxiliary valves, as shown on the plans. Stand hydrants plumb, with side nozzles parallel to the curb, and with the pumper nozzle normal to the curb, unless otherwise directed by the Engineer. Place the nozzles at the height specified by the City of Kalamazoo.
- B. For all gate valves connected adjacent to a tee or hydrant, the anchor between the fitting or hydrant and the valve shall be a 6 inch by 13 inch swivel by solid adapter with swivel gland. The swivel gland shall be located on the hydrant side of the solid adapter.
- C. Install a valve box over hydrant valve in accordance with section 3.09.
- D. Hydrants shall have a protective cover placed over hydrants prior to backfilling to ensure the hydrant is not damaged. If hydrant is damaged, the contractor shall repair or replace the hydrant at no cost to the City.
- E. If site conditions are such that it is not desirable for hydrant drain into the surrounding soil (i.e. when hydrant has less than 10 feet of separation from a sewer, high ground water, impervious or contaminated soils, etc.), hydrant drip valve plug(s) shall be installed by the Contractor onsite. Final determination on drip valve plug installation shall be made by the

Engineer or his representative. As constructed records shall be noted whether or not the drip valve plug was installed.

3.14 FIRE HYDRANT MARKER

- A. The sign shall be located between the hydrant and curb and offset from the pumper nozzle, or as directed by the Engineer. The sign shall be placed 3 feet away from the hydrant. The sign shall be single sided or double sided as directed by the Engineer or authorized representative. The sign shall have an installed height to the bottom of the sign of 7 feet above the final grade in areas with sidewalk and 5 feet above the final grade in areas without sidewalk.
- B. A fire hydrant mounted whip may be installed in addition to fire hydrant sign if approved by the Engineer. Fire hydrant whip shall be mounted to the fire hydrant opposite the pumper nozzle in accordance with the manufacturer's specifications.

3.15 FIRE HYDRANT REMOVAL

- A. If the plans show removal of a fire hydrant, remove the entire hydrant assembly, including the following:
 - 1. Auxiliary gate valve and box, unless otherwise approved by the Engineer or authorized representative.
 - 2. Internal valve assembly;
 - 3. Top bonnet;
 - 4. Standpipe; and
 - 5. Hydrant inlet body, unless otherwise approved by the Engineer.
- B. If the City of Kalamazoo approves leaving the auxiliary gate valve and box in place, remove to at least 3 feet below the pavement surface under the road, or at least 12 inches below planned grade outside the road.
- C. Stockpile the removed material at a location accessible to the City of Kalamazoo. The City of Kalamazoo will maintain ownership of the hydrant, and will remove the assembly from the project site

3.16 RELOCATING FIRE HYDRANTS

- A. If the plans show relocating a hydrant, arrange for the City of Kalamazoo to shut down the hydrant auxiliary valve. Remove the hydrant and reinstall at the required location. Reconnect the hydrant to the water main by shutting down the main, tapping a new hydrant outlet, or using the existing outlet. Install piping as required. If the relocated hydrant does not pass testing the hydrant shall be replaced with new at no cost to the City of Kalamazoo.

3.17 MISCELLANEOUS FITTINGS

- A. Install the following at the locations shown on the plans and in accordance with good construction practices and manufactures recommendations:
 - 1. Elbows,
 - 2. Tees,
 - 3. Corporation stops,
 - 4. Blow offs,
 - 5. Pipe adapters,
 - 6. Pipe couplings,

7. Retaining glands, and
8. Other miscellaneous fittings.

3.18 AIR RELEASE VALVES AND VAULTS

- A. Construct air release valves and vaults in accordance with the current WA-4-Series and WA-5-Series of the City of Kalamazoo Standard Plans.
- B. When installing the air release valves in conjunction with new water main construction, the contractor shall use ductile iron fittings.
- C. When installing the air release vaults as a retrofit to existing water main, live taps may be performed as directed by the engineer.

3.19 BACKFILLING AND COMPACTING

- A. Backfill and compaction shall be in accordance with Michigan Department of Transportation Standard plan for utility trenches R-83-Series.
- B. Backfilling Under Existing Conduits – Where it is necessary to undercut or replace existing utility conduits and/or service lines, the excavation beneath such lines shall be backfilled the entire length with granular bedding material tamped in place in 6-inch layers to the required density. The granular bedding shall extend outward from the spring line of the conduit a distance of 2-feet on either side and thence downward at its natural slope.
- C. Backfilling with Excavated Material – Unless otherwise specified or directed, material excavated in connection with the work shall be used for backfilling and other filling purposes, if it meets all requirements given elsewhere in this specification.
- D. Backfill Immediately Following Inspection – All trenches and excavations shall be backfilled immediately after pipe is laid therein, unless otherwise directed by the Engineer or authorized representative. Under no circumstances shall water be permitted to rise in un-backfilled trenches after pipe has been placed.
- E. Service leads shall not be backfilled until the pipe ends are referenced and the Engineer or authorized representative has measured the pipe for payment.
- F. Backfilling around and over structures and pipes shall be carefully done by hand and tamped with suitable tools of approved weight to a point 1-foot above the top of pipe. Selected material or, where specified or ordered by the Engineer, special backfill material shall be used in this area. The material shall be placed in uniform layers not exceeding 6-inch in depth up each side. Each layer shall be placed, then carefully and uniformly tamped to the specified density so as to eliminate the possibility of lateral displacement of pipe or structure.
- G. Backfilling by Machinery – After the backfill has been placed and compacted around the boxes and pipe to a height of 1-foot above the top. The remainder of the trench may be backfilled by machine. The backfill material shall be deposited in horizontal layers and each layer shall be thoroughly compacted to the specified density by approved methods before a succeeding layer is placed. In no case will backfill material from a bucket be allowed to fall directly on a structure or pipe and in all cases the bucket must be lowered so that the shock of the falling material will not cause damage.

3.20 COMPACTION REQUIREMENTS

- A. Compact each layer to 95% (90% if outside the influence of the roadway) maximum density as tested by the Michigan Department of Transportation Density Testing and Inspection Manual.

3.21 COMPACTION TEST

- A. Trenches and excavation around structures shall be backfilled and consolidated in layers, as specified, to the existing ground surface. Compaction tests shall be performed on each layer immediately after compaction.
- B. Initial test series for each type of backfill material shall be continued until the method of consolidation employed has proven to attain the required compaction. Any change in the proven method of consolidations will require additional testing and field verification of compaction.
- C. Subgrade below pavements, curbs, sidewalks, and structures shall be consolidated as specified. Compaction tests shall be performed to verify specified consolidation.

3.22 HYDROSTATIC TESTING

- A. Perform hydrostatic testing of water mains in accordance with AWWA C600.
- B. Ensure City of Kalamazoo personnel witness pressure testing. Give the City of Kalamazoo personnel at least 1 full working day notice before testing.
- C. Provide the personnel, temporary timber bracing, plugs, test pumps, temporary connections to the Municipal water system, and any other required apparatus. Provide the water for hydrostatic testing if not available from the City of Kalamazoo. Water must be pumped from a measurable source in order to determine testing allowance water.
- D. Before applying test pressure, expel air from the pipe in increments of no greater than 1,000 feet. Pressure test each section of water main. If the Contractor chooses not to pressure test against an existing valve, a new valve may be installed at the expense of the Contractor.
- E. Pipe shall be pumped with water to a minimum test pressure of 150 pounds per square inch (psi) at the highest point of elevation to begin test. Test shall last for at least 2 hours, with a maximum drop of pressure of 5 psi. If the pressure drop is greater than 5 psi but less than 20 psi, a testing allowance water test shall be performed. Testing allowance water, as measured by the quantity of water pumped into the pipe to attain the pressure at which the test began must not exceed the testing allowance.
- F. Testing allowance water is determined using the following formula

$$L = \frac{SD\sqrt{P}}{148,000}$$

Where

- L= testing allowance water in gallons per hour
- S= length of pipe in feet
- D= actual pipe diameter in inches, and
- P= 150 psi

- G. If testing allowance water is above the allowable limit occurs during hydrostatic testing, remove backfill to expose pipe and repair the joints. Repeat testing after repairs are complete. If multiple leaks occur the contractor may be required to reinstall main at Contractors expense.
- H. Correct visible leaks regardless of the amount of leakage. Replace faulty pipes, fittings, gate valves, or other accessories disclosed by testing. Repeat the test until the pipes, fittings, gate valves, and other accessories meet the requirements.

3.23 DISINFECTION, FLUSHING, AND BACTERIOROLOGICAL TESTING

- A. Disinfect the water main in accordance with AWWA C651 and applicable Michigan Department of Environment, Great Lakes, and Energy (EGLE) regulations after successful hydrostatic testing.
- B. Disinfect and flush new, and portions of existing, water mains as required by the EGLE.
- C. Use blow offs, fire hydrants, or other means as shown on the plans or approved by the Engineer, or authorized representative, to flush water mains in accordance with AWWA C651, with a velocity of at least 3 feet per second. Provide hoses and other equipment and arrange a means of disposing of the water without damaging the work or adjacent property.
- D. Use the continuous feed method with chorine added simultaneously with the water. Add chlorine or liquid hypochlorite to meet the requirement of at least 25 milligrams per liter of chlorine. Slowly add the water to the main and allow it to stand for at least 24 hours. At the end of the 24-hour period, ensure the chlorine residual is a minimum of 10 milligrams per liter. If not met, re-chlorinate and flush the water main until a minimum 10 milligrams per liter residual remains after 24 hours.
- E. After completing disinfection, initially flush the water mains with water at a velocity of at least 3 feet per second to replace the entire volume of chlorinated water in the pipeline. After initial flushing, perform final flushing until the residual chlorine content meets the standard level for the water distribution system. The City of Kalamazoo may require a waiting period after flushing and before bacteriological sampling.
- F. Dispose of chlorinated water in accordance with applicable state and local requirements. If necessary, apply a reducing agent to the water to neutralize the chlorine and create a chlorine residual of no greater than 1 ppm. Dechlorination shall be in accordance with AWWA C655.
- G. After flushing, perform bacteriological testing in accordance with AWWA C651 and EGLE requirements. Test chlorine residuals before taking each bacteriological sample. Ensure the chlorine residual is less than 1.5 milligrams per liter before taking a bacteriological sample. The City of Kalamazoo will collect samples from each branch of pipe in the presence of the Engineer, or authorized representative, and contractor personnel. The City of Kalamazoo will be responsible for the transportation of the samples to a State of Michigan approved lab for testing. Two consecutive bacteriologically safe tests at 24-hour intervals for each section of pipe are required. Acceptable tests are negative for bacteria and as otherwise defined by AWWA C651 and EGLE regulations.
- H. If a bacteriological test fails, repeat disinfection, flushing, and testing.
- I. Pressure and chlorination taps shall be removed within one business day of passing tests, so main can be activated.

3.24 POLYETHYLENE ENCASEMENT

- A. Polyethylene encasement will be required for all ductile iron installations when the soil test evaluation is greater than or equal to 10 points based as indicated in AWWA/ANSI C105/A21.5 or as directed by the Engineer. Sampling of the soils is to be completed by the developer or municipality responsible for the installation.
- B. Install polyethylene encasement on water mains and fittings installed through concrete floor and foundations and as indicated on the plans in accordance with the manufacturer's installation instructions and AWWA/ANSI C105/A21.10. Appropriately sized polyethylene encasement shall be used so that there are no longitudinal splices. This may require using one or more size larger diameter encasement than the pipe installed.

- C. Polyethylene encasement shall be required for all installations when groundwater is detected in the utility trench.
- D. Polyethylene encasement shall be required for all directional drilling installations involving ductile iron pipe.

3.25 WATER INFRASTRUCTURE IN STEEL CASING

- A. Work shall be performed in accordance with section 401 of the Michigan Department of Transportation *Standard Specifications for Construction* and as detailed herein. In all cases, the Contractor shall submit a work plan detailing the following:
 - 1. Means and methods for bracing and shoring;
 - 2. Methods of maintaining and adjusting line and grade;
 - 3. Drilled/bored diameter;
 - 4. Drill hole stabilization procedures;
 - 5. Size and location of the auger head relative to the casing;
 - 6. Methods of dealing with cobbles/boulders and obstructions;
 - 7. Estimated jacking thrust required;
 - 8. Method of monitoring casing elevation;
 - 9. Thrust block design calculations;
 - 10. Record keeping system to document casing advance and jacking pressures;
 - 11. Grouting procedures;
 - 12. Temporary dewatering measures and;
 - 13. Mitigation procedures if sinkholes or settlement above the pipe occurs or excessive movement of the settlement monitors is observed.
- B. Minimum Allowable Depths.
 - 1. The minimum allowable depth of the Horizontal Auger Bore (HAB) installed casing pipe shall be in accordance with Table 3.2

Table 3.2 Minimum Allowable Depths Table	
Location	Minimum Depth
Base of Rail	6 Feet
Existing Ground	5 Feet
Roadway	5 Feet
Ditch Flowline	5 Feet

- C. Access Pits.
 - 1. Excavate jacking and receiving pits as necessary. Provide and install all sheeting, shoring, bracing and any other earth retention measures in accordance with section 704 of the Michigan Department of Transportation *Standard Specifications for Construction*. Provide site drainage and subsurface dewatering and other items associated with the operation as necessary to facilitate the proposed work.
- D. Lead Auger/Overcut Allowance.

1. A full-size auger section shall be used as the lead section of the casing. The auger shall not protrude from the leading edge of the casing. However, if soil conditions halt the movement of the casing, the auger shall be allowed to protrude not more than 1 inch in front of the casing during the boring operation. Overcut is the annular space between the excavated hole and the outside diameter of the casing pipe. The allowable overcut diameter is one inch greater than the casing pipe radius.
- E. Watertight joints.
1. Watertight joints are required to ensure the integrity of the road and railroad bed. Casing pipe shall be constructed to prevent water leakage or earth infiltration and must be certified free from any breaks or leaks throughout its entire length.
- F. Lubrication Fluids.
1. Lubrication fluids are specifically required for this method regardless of the soil conditions. Any deviations from the use of lubrication shall require prior approval for the Engineer. The Contractor shall install vents on either side of the casing pipe to prevent fracking during installation. These vents shall also be used as relief in case of a water main break. Lubrication fluids, consisting of a mixture of water and bentonite or bentonite/polymer, shall be used in the annular space between the casing being installed and the native soil to stabilize and lubricate the drill hole. Grease will not be allowed for use as lubrication for this purpose.
- G. Pipe Locating and Tracking.
1. One of the following tracking, locating, and guidance systems shall be used:
 - a. Waterline system.
 - b. Mechanical control head.
 - c. Electronic (inertial) control head.
 - d. Walkover system.
 - e. Laser guided tunnel attachment.
 - f. Laser guided pilot rod.
 2. The Contractor will be responsible for submitting their proposed pipe locating tracking method at the preconstruction meeting for approval.
- H. Settlement/Heaving Monitoring.
1. Settlement/Heaving monitoring shall be performed in a manner that will minimize the movement of the ground in front of, above, and surrounding the horizontal auger bore operation; and will minimize subsidence of the surface above and in the vicinity of the boring. The ground shall be supported in a manner to prevent loss of ground and keep the perimeter and face of the boring stable at all times, including during shutdown periods. A survey shall be performed one day prior to initiating this operation at each required monitoring location. A similar survey shall then be performed at each location, on a daily basis, until the permitted activity has been completed. All survey readings shall be recorded to the nearest one-hundredth (0.01) of a foot. Digital photographs of the pavement and rail conditions shall also be taken prior and after the pipe installation. Specific monitoring locations and requirements may also be provided for railway crossings.
- I. Ground Water Control.

1. Dewatering shall be conducted whenever there is a high ground water table level to prevent flooding and facilitate the operation. The water table elevation shall be maintained at least 1 foot below the bottom of the casing at all times. When needed, dewatering may be initiated prior to any excavation.
2. Minor water seepage or pockets of saturated soil may be effectively controlled through bailing or pumping. This control shall be accomplished without removing any adjacent soil that could weaken or undermine any access pit, its supports, or other nearby structures.
3. Larger volumes of ground water shall be controlled with one or more well points or with staged deep wells. Well points and staged deep well pumping systems shall be installed and operated without damage to property or structures, and without interference with the right of the public, owners of private property, pedestrians, vehicular traffic, or the work of other contractors. Any pumping methods used for dewatering and control of ground water and seepage shall have properly designated filters to ensure that the adjacent soil is not pumped along the water. Well diameter, well spacing and the pump's pumping rate shall provide adequate draw down of the water level. Wells shall be located to intercept ground water that otherwise would enter the access pit excavation and interfere with the work. Upon removal of a well, the hole shall be filled and grouted.
4. Existing storm sewers shall only be used to discharge water from the dewatering operation in accordance with a permit obtained from the appropriate storm sewer owner. Filters or sediment control devices shall be required to ensure that the existing system is not adversely affected by construction debris or sediment.

J. Casing End Seals/Bulkheads

1. Casing ends shall be enclosed using 1/8 inch thick synthetic rubber casing ends seals in accordance with section 2.19.C of this document. Ensure end seals are water tight and attach securely to the casing pipe and the carrier pipe (water main). Ensure end seals are acceptable to the Engineer.

K. Backfill Requirements.

1. Remove the pits and backfill the excavations as necessary with material meeting the standard specifications as approved by the Engineer.

L. Railroad Specific Requirements.

1. For Steel casing pipe jacked in place under a railroad, the following will apply in accordance with the current AREMA Manual;
 - a. When steel casing pipe is used, the joints must be fully closed by welding or mechanical means as approved by the Engineer.
 - b. Minimum cover over the casing must be at least 6.0 feet from the bottom of the railroad tie to the top of the casing pipe at its closest point.
 - c. Casing pipe must extend beyond the limits of the entire railroad right-of-way.
 - d. Jacking construction requirements must be in accordance with the current AREMA Manual, Chapter 1, Part 4.

3.26 INSTALLATION OF LINE STOPS AND INSERTION VALVES

- A. Line Stops and Insertion Valves shall be performed in the locations as detailed on the plans or as directed by the Engineer. Prior to installation of the line stop or insertion valve, coordinate the deactivation of the water main so that all customers have been given proper notification

of the shutdown. No work shall be performed without the Engineer or authorized representative present.

B. Excavate and expose the water main. Remove scale from the water main and make sure there are no flaws which would affect the seal with the saddle.

C. Line Stops

1. Install permanent line stop body on the pipeline and perform line stop according to manufacturer's instructions. Upon completion of the work associated with the line stop, reactivate the water main and install permanent blind flange on the line stop body. Ensure that all as built information is recorded and submitted as detailed in section 1.03.

D. Insertion Valves

1. Install Insertion Valve body on the pipeline and perform valve insertion according to manufacturer's instructions. Operate the valve to ensure that it is fully functional.

2. Construct valve vault as detailed in WA-8-A of the City of Kalamazoo Standard Plans. Ensure that all as built information is recorded and submitted as detailed in section 1.03.

3.27 FINAL RESTORATION

A. Contractor shall restore site to preconstruction condition or better, or as detailed on the plans.

B. Final grade shall be 5 feet above completed water main or water service line, unless otherwise approved by the Engineer. If final grade is changed greater than 6 inches from the approved plans, the Developer or Contractor shall raise or lower water main and water services so that they are maintained at 5 feet below final grade. All costs associated with this work shall be paid for by the Developer or Contractor.

PART 4 MEASUREMENT AND PAYMENT

4.01 PAY ITEMS

Measurement a payment may not apply if construction is not being funded with City of Kalamazoo funds. Please review signed construction contract for actual measurement and payment specifications.

Pay Item	Pay Unit
Water Main, DI __ inch, Tr Det __	Foot
Water Main, DI __ inch, in Casing.....	Foot
Water Main, DI __ inch, HDD.....	Foot
Gate Valve and Box, __ inch,.....	Each
Butterfly Valve and Box, __ inch.....	Each
Polyethylene Encasement.....	Foot
Water Main, __ inch, Cut and Plug	Each
Fire Hydrant	Each
Hydrant, Rem	Each
Hydrant Relocate, Case __	Each
Water Serv	Each
Water Serv, Long.....	Each
Water Serv, Conflict	Each
Water Serv, Yard	Each
Copper Tubing, Additional Length	Foot
Water Serv, 2 inch.....	Each
Water Serv, Conflict, 2 inch	Each
Copper Tubing, Additional Length, 2 inch	Foot

Steel Casing Pipe, __ inch, Jacked in Place.....Foot

4.02 MEASUREMENT OF PAY ITEMS

- A. Payment for Water Mains shall be measured based on the sizes and trench details required, along the centerline of the pipe, with no deductions for fittings. The unit price of Water Main, DI, includes the cost of the following:
 - 1. Excavation and backfill;
 - 2. Dewatering operations (trench and/or pipe);
 - 3. Provide temporary water system to maintain service during construction;
 - 4. Hydrostatic testing;
 - 5. Disinfecting and flushing the water main and bacteriological testing;
 - 6. All material, labor and equipment necessary to remedy an unsatisfactory hydrostatic test, including removing and replacing any backfill;
 - 7. Providing and installing fittings, gaskets, bracing or sheeting, blocking and miscellaneous items for installing pipe and reconnecting to the Municipal Water System;
 - 8. Preparing and providing as-constructed plans.

- D. The City of Kalamazoo may withhold payment and/or final acceptance until the City of Kalamazoo accepts the as-built plans.

- E. The cost of dewatering of trenches, pipe, or both associated with alterations to the Municipal Water System, is included in the unit price for relevant items of work.

- F. The cost of excavating, disposing of excess material, and providing, placing, and compacting the backfill, is included in the unit price for related items of work.

- G. The cost of removing or abandoning existing water mains, gate valve boxes, and other appurtenances to provide clearance for the proposed water main or roadway, is included in the unit price for relevant items of work.

- H. Payment for Gate Valves, Butterfly Valves, and Valve Boxes, shall be as follows:
 - 1. The unit prices of **Gate Valve and Box** and **Butterfly Valve and Box**, of the types and sizes required, include the cost of providing and installing the valve and valve box, complete and ready for use.

- I. Payment for water services 1 ¼ and smaller shall be as follows:
 - 1. **Water Serv** refers to services between the water main and the curb shut off no greater than 33 feet long. **Water Serv, Long** refers to services between the water main and the curb shut off greater than 33 feet long and up to 66 feet in length. **Water Serv, Yard** refers to the services between the curb shut off and the water meter setting, up to 25 feet in length. **Copper Tubing, Additional Length** refers to the additional copper tubing and work needed when services between the curb shut off and the water meter setting are over 25 feet in length, and when the length of the service between the center of the road and the curb shut off exceeds 66 feet. **Water Serv, Conflict** refers to relocating only a portion of a water service.

- J. Payment for water services 2 inches in size shall be as follows:
 - 1. **Water Serv, 2 inch** refers to the services between the water main and the water meter setting no greater than 58 feet in length. **Water Serv Conflict, 2 inch** refers to relocating only a portion of a 2 inch water service. **Copper Tubing, Additional length, 2 inch** refers to the additional copper tubing and work needed when services exceed 58

feet in length.

- K. Services with a diameter larger than 2 inches will be measured and paid for as water mains.
- L. The unit prices for **Water Serv, Water Serv, Long, Water Serv, Yard, Copper Tubing, Additional Length, Water Serv Conflict, Water Serv, 2 inch, Water Serv Conflict, 2 inch,** and **Copper Tubing, Additional Length, 2 inch**, include the cost of the following, unless otherwise accounted for in other pay items:
 - 1. Earth excavation;
 - 2. Removing pavement;
 - 3. Replacing pavement;
 - 4. Jacking and boring;
 - 5. Providing and installing type K copper tubing, service saddle, corporation stops, service stops, and service boxes;
 - 6. Disinfecting;
 - 7. Providing, placing, and compacting backfill;
 - 8. Slope Restoration to equal or better conditions; and
 - 9. Miscellaneous material, equipment, or operations.
- M. Payment for additional service connections, not shown on the plans, but maintained, protected, and reconnected or disposed of by the Contractor will be paid for as **Water Serv**, or **Water Serv, Long**.
- N. The pay item **Water Serv, Conflict** will apply only to portions of water services requiring relocation due to direct conflict with utilities, other items of work, or as otherwise approved by the City of Kalamazoo. Payment for all other relocations requiring replacement of corporation or service stops will be paid for as Water Serv or Water Serv, Long.
- O. Payment for **Water Main, __inch, Cut and Plug** includes the cost of cutting the existing water main, providing and placing the required plug, and thrust blocks.
- P. Payment for **Fire Hydrant** includes the cost of providing and installing the hydrant, hydrant valve, valve box, and all pieces between the valve and hydrant, including the coarse gravel and concrete base, fire hydrant marker at the locations shown on the plans in a ready-for-use condition unless noted otherwise.
- Q. Payment for **Hydrant, Rem** includes the cost of breaking down the auxiliary gate valve, gate box, the hydrant assembly, backfilling, and plugging the opening in the existing main.
- R. Payment for **Hydrant, Relocate, Case __** (of the case required), includes the cost of vertically adjusting the relocated hydrant to final grade and the following:
 - 1. Case 1 includes the cost of removing the hydrant, extending the existing hydrant lead from the gate valve, reinstalling the hydrant in a ready-for-use condition, adjusting the existing gate box and hydrant to final grade, and providing and installing sleeves, fittings, and joint restraints.
 - 2. Case 2 includes the cost of removing the existing hydrant, gate valve and box, and reinstalling the hydrant and gate valve in a ready-for-use condition, adjusting the existing gate box and hydrant to final grade, and providing and installing the cutting-in-sleeve, pipe coupling, tee, elbow, and joint restraints.
- S. Payment for **Steel Casing Pipe, __inch, Jacked in Place** of the size required will be paid for by the length installed. The unit price for **Steel Casing Pipe, Jacked in Place** includes the cost of excavating the pits, providing and installing sheeting, bracing, and any other safety devices, providing jacking equipment: drainage and dewatering; bulkheading and sealing the casing, providing and installing vents, grouting the annular space between the casing and native soil and any other items associated with the operation.

- T. Payment for **Water Main, DI, __inch, in Casing**, of the size required will be paid for by the length installed. The unit price for **Water Main, DI __inch, in Casing** shall include the cost for furnishing and installing the water main and casing spacers inside the casing.
- U. Payment for **Water Main, DI, __inch, HDD**, of the size required will be paid for by the length installed. The unit price shall include the cost of all equipment and materials, excavation and backfill, dewatering operations (trench, pit or pipe), temporary water system to maintain service during construction, hydrostatic testing, disinfecting and flushing the water mains, and bacteriological testing, all materials, labor and equipment necessary to remedy and unsatisfactory hydrostatic test, including removing and replacing any backfill, providing and install all, gaskets, bracing or sheeting, blocking and miscellaneous items for installing pipe of the required size and material and reconnecting to the water system as shown on the plans.

END OF SECTION

This page was intentionally left blank.

WA-1-D

ITEM	QTY.	#	DESCRIPTION
1	1	39887	6" HYDRANT W/CARROLL DRAIN
2	2	70000	CONNECTING PIECE (13")
3	4	33801	6" GASKET (MJ)
4	1	96696	6" GATE VALVE (MJ)
5	1	08550	VALVE BOX BOTTOM
6	1	08520	VALVE BOX TOP SECTION
7	1	08500	VALVE BOX RING CASTING
8	1	08490	VALVE BOX COVER
9	1	91440	6" TEE MJ
10	1	91525	8" X 6" TEE MJ W/MEGALUGS
11	1	91750	10" X 6" TEE MJ W/MEGALUGS
12	1	91825	12" X 6" TEE MJ W/MEGALUGS
13	1	91909	16" X 6" TEE MJ W/MEGALUGS
14	1	91940	20" X 6" TEE MJ W/MEGALUGS

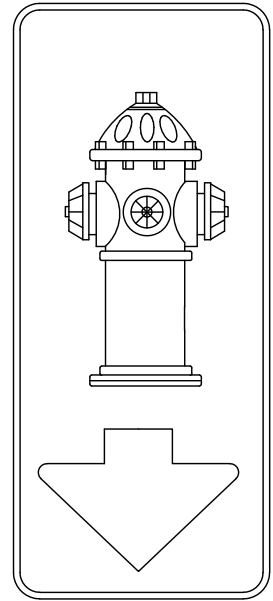

TYPICAL HYDRANT SIGN

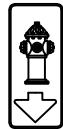

DOUBLE SIDED HYDRANT SIGN

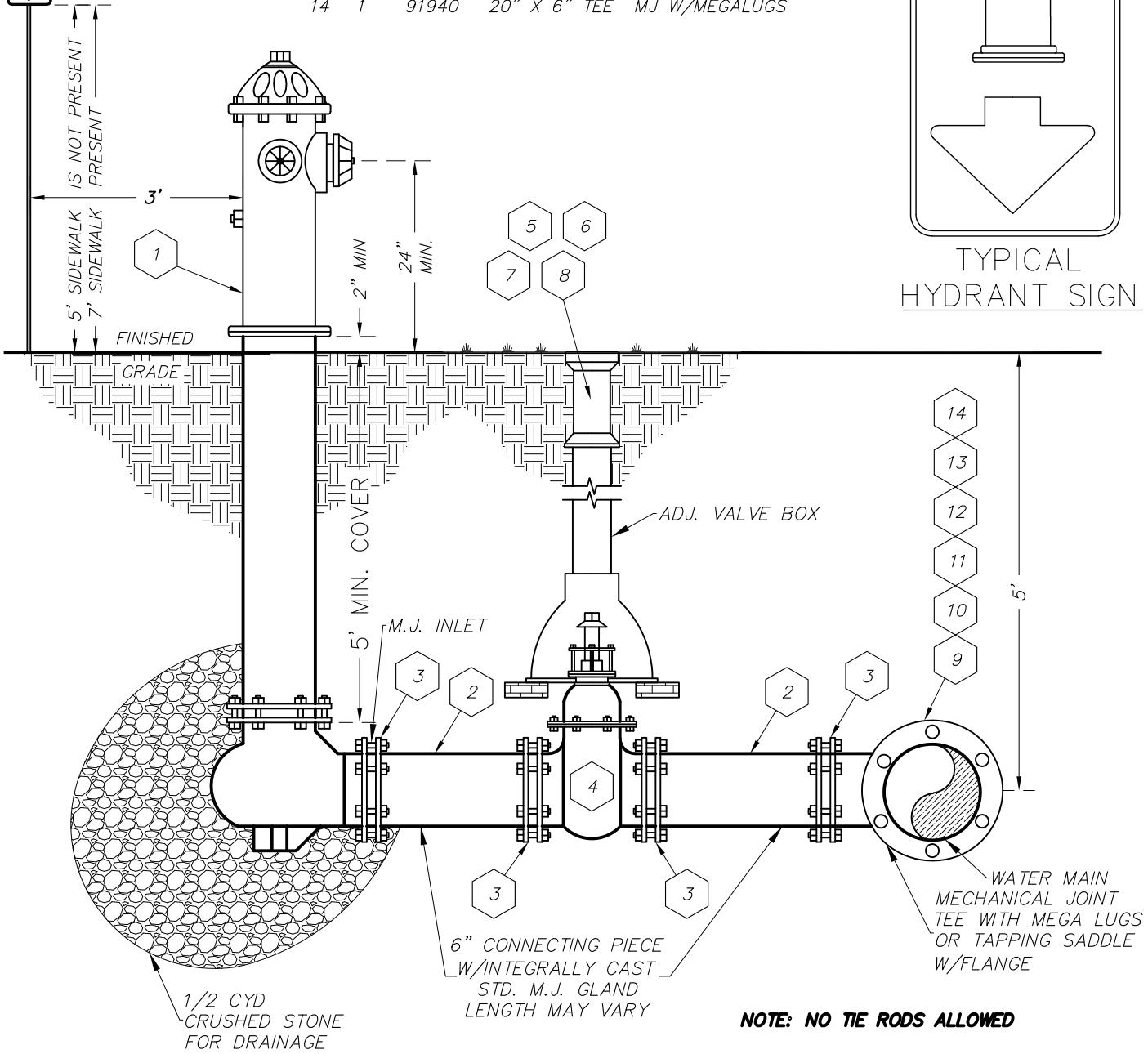

CITY OF KALAMAZOO
 Department Of Public Services

TYPICAL FIRE HYDRANT & GATE VALVE DETAIL

RECOMMENDED BY _____	DATE _____
APPROVED BY _____	
APPROVED BY _____	
ACCEPTED BY _____	

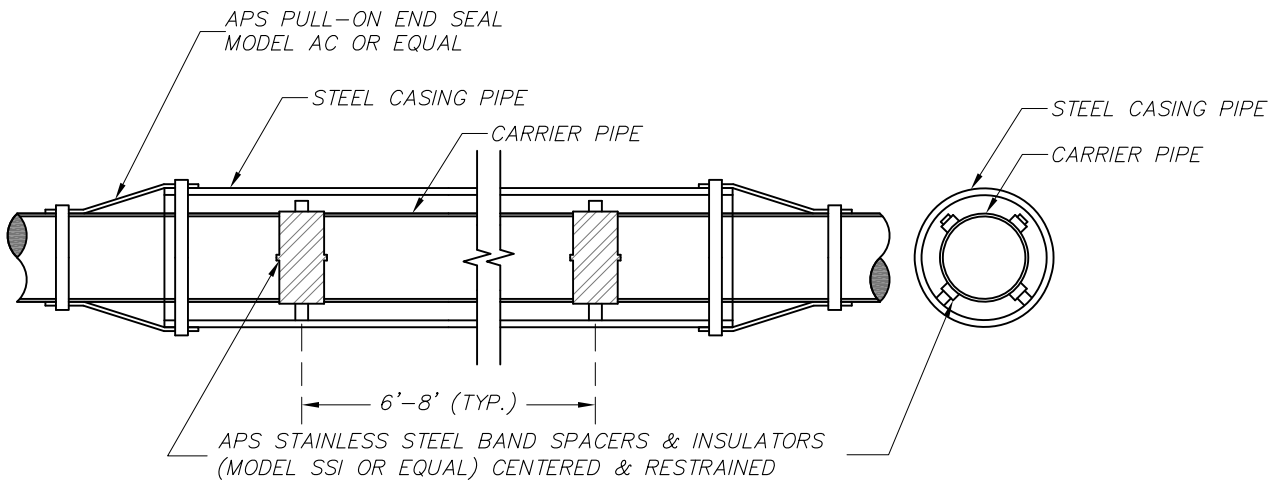

CASING CARRIER PIPE DETAIL

SIZE CASING AND CARRIER PIPES PER PLAN AND SPECIFICATIONS

TYPICAL BAND SPACER POSITIONING:
 ONE PLACED NOT MORE THAN 1 FOOT FROM EACH END OF THE CASING AND
 PIPE JOINTS WITH SUBSEQUENT SPACERS PLACED EVERY 6-8 FEET THEREAFTER.
 FOR 18 FOOT PIPE THERE SHALL BE THREE BAND SPACERS.
 FOR 20 FOOT PIPE THERE SHALL BE FOUR BAND SPACERS.



CITY OF KALAMAZOO
 Department Of Public Services

CASING CARRIER PIPE

RECOMMENDED BY _____	DATE _____
APPROVED BY _____	
APPROVED BY _____	
ACCEPTED BY _____	

WA-3-C

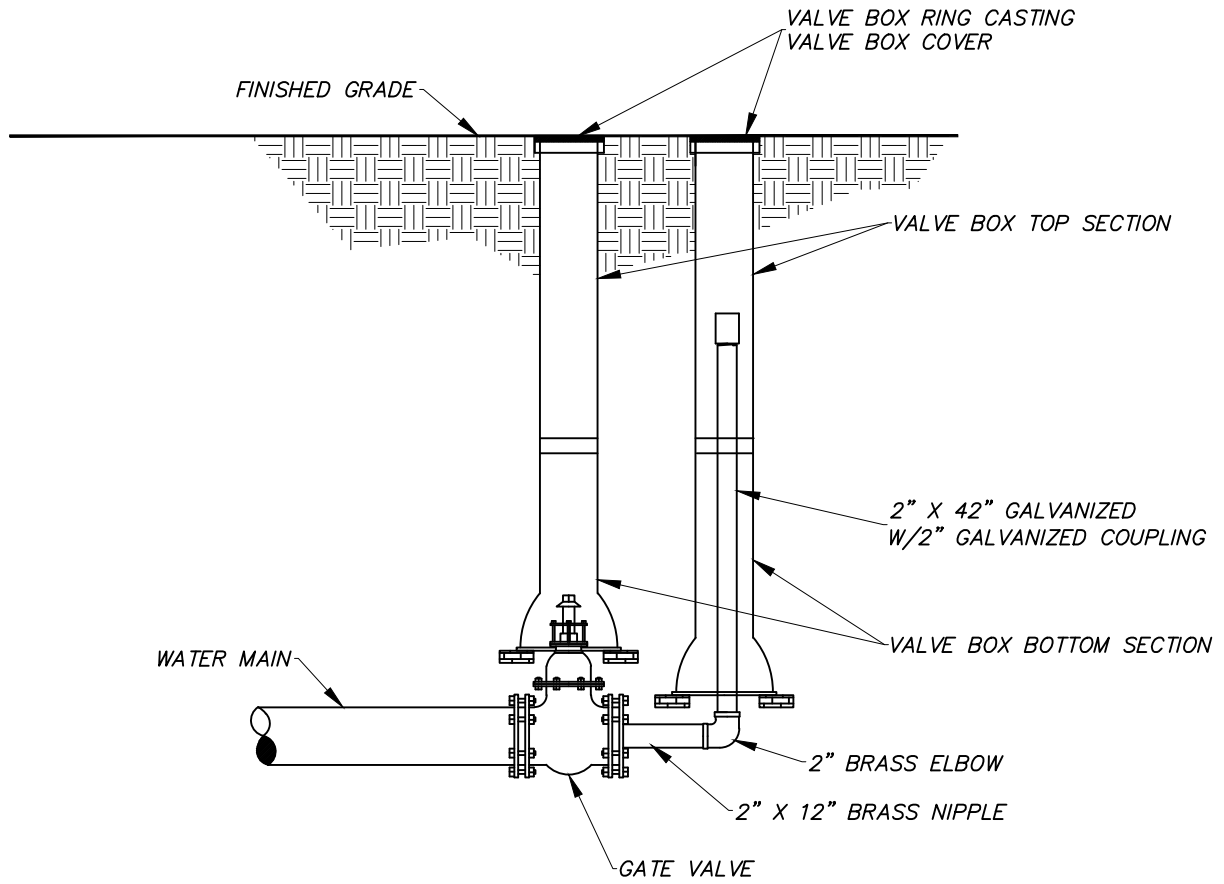

NOT TO SCALE

J:\CAD STANDARDS\STANDARD DETAILS\WATER\UPDATED DRAWINGS\ACAD DRAWINGS\WA-3-B BLOW OFF CONNECTION 2 INCH.dwg, 6/12/2016 12:01:24 PM



CITY OF KALAMAZOO
Department Of Public Services

2" BLOW OFF CONNECTION

	DATE
RECOMMENDED BY _____	
APPROVED BY _____	
APPROVED BY _____	
ACCEPTED BY _____	

NOTE:
LIFT HOLES SHALL BE FILLED
IN WITH NON-SHRINK MORTAR

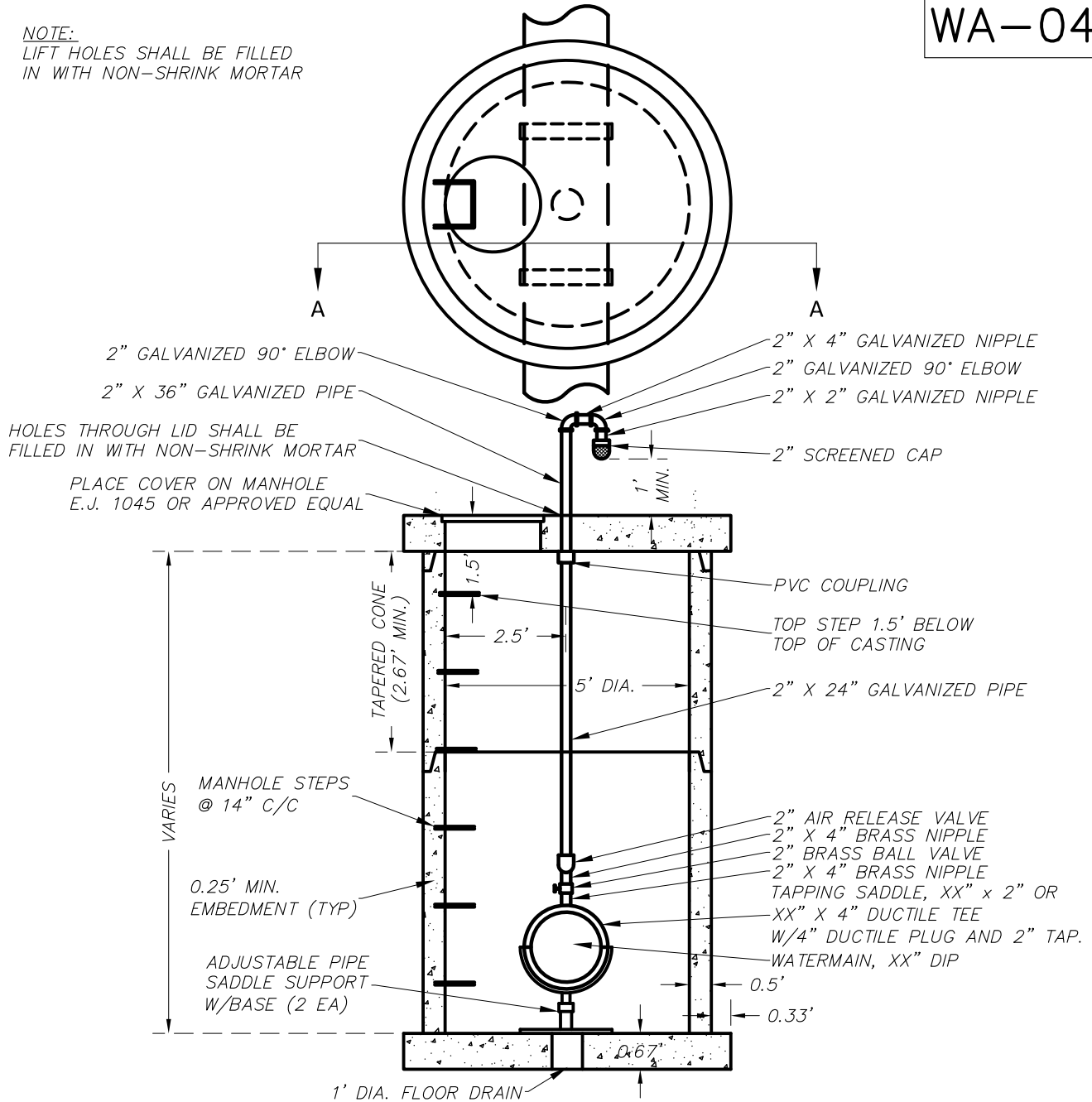

TYPICAL 2" AIR RELEASE MANHOLE

PRECAST REINFORCED CONCRETE SHOWN (OTHER OPTIONS INCLUDE
CONCRETE BLOCK, BRICK OR CAST IN PLACE WALL SECTIONS)

SCHEDULE OF FITTINGS

ITEM DESCRIPTION	QUANTITY
AIR RELEASE VALVE, 2"	1
GALVANIZED PIPE, 2" X 60"	1
GALVANIZED NIPPLE, 2" X 4"	1
GALVANIZED NIPPLE, 2" X 2"	1
GALVANIZED 90° ELBOW, 2"	2
PIPE SUPPORT BASE	2

ITEM DESCRIPTION	QUANTITY
TAPPING SADDLE, XX X 2"	1
BRASS BALL VALVE, 2"	1
BRASS NIPPLE, 2" X 4"	2



CITY OF KALAMAZOO
Department Of Public Services

AIR RELEASE MANHOLE

RECOMMENDED BY _____ DATE _____

APPROVED BY _____

APPROVED BY _____

ACCEPTED BY _____

WA-05-C

NOTE:
LIFT HOLES SHALL BE FILLED
IN WITH NON-SHRINK MORTAR

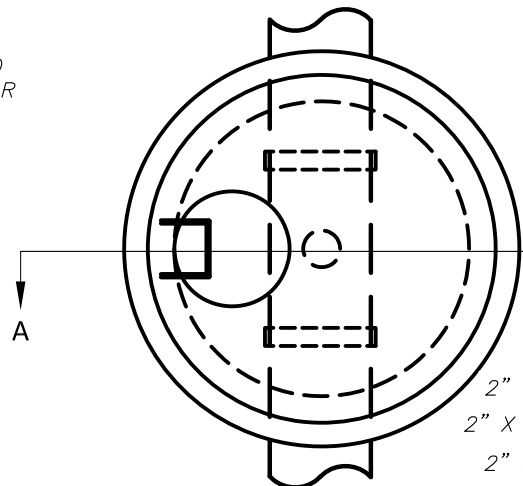

- 2" GALVANIZED 90° ELBOW
- 2" X 4" GALVANIZED NIPPLE
- 2" GALVANIZED 90° ELBOW
- 2" X 2" GALVANIZED NIPPLE
- 2" SCREENED CAP

BOLLARD POSTS
AS SPECIFIED
BY ENGINEER

PLACE COVER ON MANHOLE
E.J. 1045 OR APPROVED EQUAL

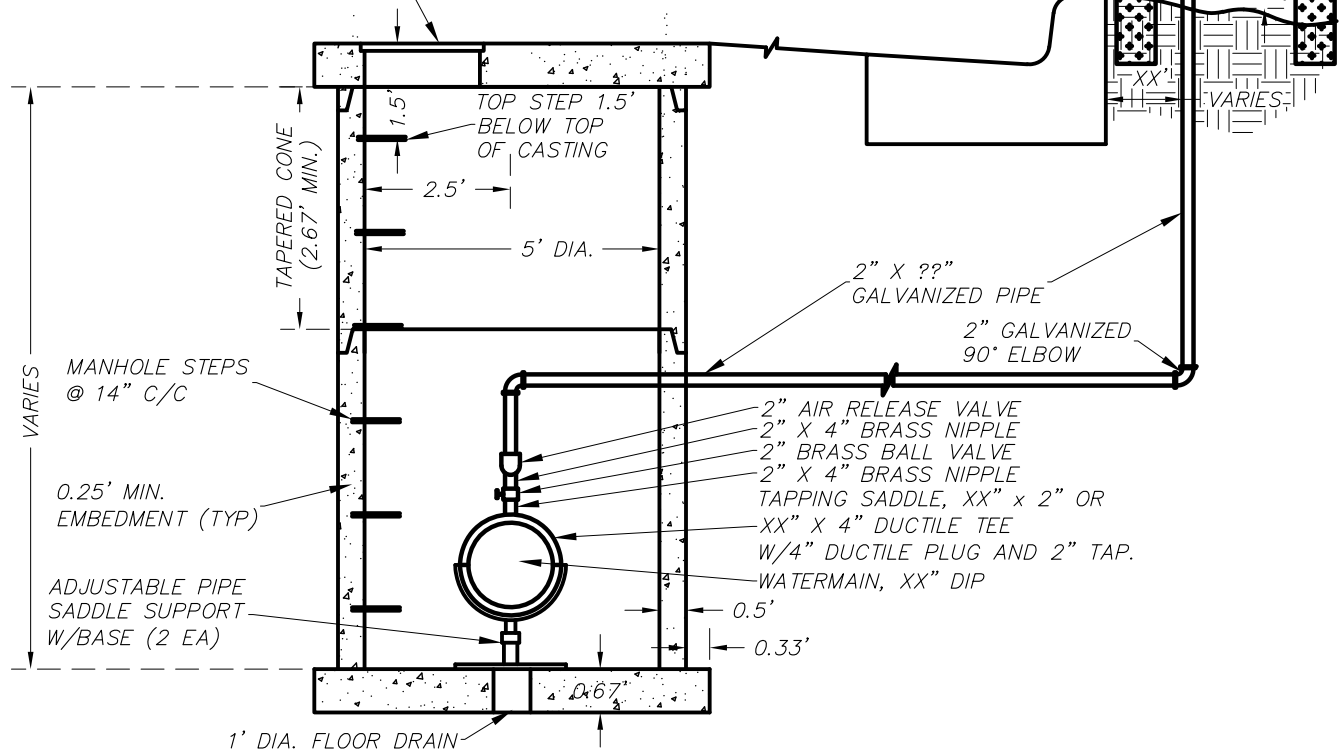

TYPICAL 2" AIR RELEASE MANHOLE

PRECAST REINFORCED CONCRETE SHOWN (OTHER OPTIONS INCLUDE
CONCRETE BLOCK, BRICK OR CAST IN PLACE WALL SECTIONS)

SCHEDULE OF FITTINGS

ITEM DESCRIPTION	QUANTITY
AIR RELEASE VALVE, 2"	1
GALVANIZED PIPE, 2" X 60"	1
GALVANIZED NIPPLE, 2" X 4"	1
GALVANIZED NIPPLE, 2" X 2"	1
GALVANIZED 90° ELBOW, 2"	2
PIPE SUPPORT BASE	2

ITEM DESCRIPTION	QUANTITY
TAPPING SADDLE, XX X 2"	1
BRASS BALL VALVE, 2"	1
BRASS NIPPLE, 2" X 4"	2

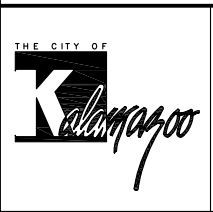

CITY OF KALAMAZOO
Department Of Public Services

AIR RELEASE MANHOLE IN ROADWAY

RECOMMENDED BY	DATE
APPROVED BY _____	
APPROVED BY _____	
ACCEPTED BY _____	

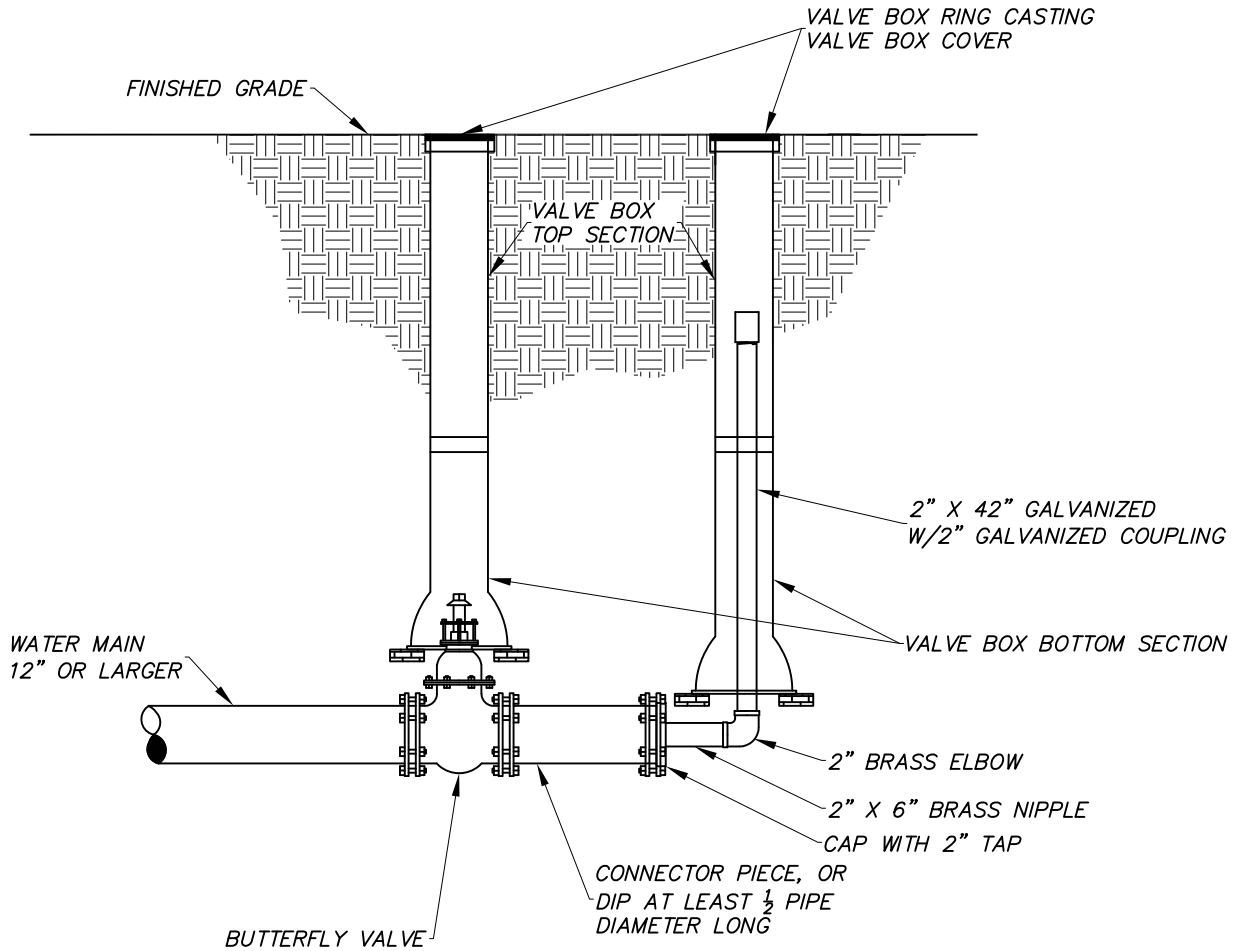

NOT TO SCALE



CITY OF KALAMAZOO
Department Of Public Services

**2" BLOW OFF
CONNECTION
12" OR LARGER MAIN**

RECOMMENDED BY _____
 APPROVED BY _____
 APPROVED BY _____
 ACCEPTED BY _____

DATE

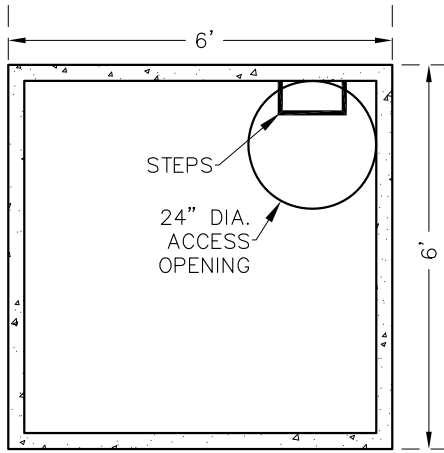

TOP VIEW

NOTES:

1. METER VAULT DESIGN TO BE SUBMITTED AND APPROVED FOR EACH INDIVIDUAL INSTALLATION. DESIGN SHALL CONFORM TO KALAMAZOO WATER ENGINEERING STANDARDS LATEST REVISION.
2. THE DISTANCE BETWEEN RUNGS, CLEATS AND STEPS SHALL NOT EXCEED 12 INCHES AND SHALL BE UNIFORM THROUGHOUT THE LENGTH OF THE LADDER.
3. PLACEMENT OF CURB BOX CAN VARY FROM A MAXIMUM OF 5 FEET OUTSIDE THE PROPERTY LINE TO A MAXIMUM OF 5 FEET INSIDE THE PROPERTY LINE. PLACEMENT OF THE CURB BOX OUTSIDE THE PROPERTY LINE IS PREFERRED.
4. ACCESS COVER - FORD MC-24-MB-T WITH AN INNER LID, VESTAL 32-055, 32-104, AND 32-046 OR APPROVED EQUAL.

TOP OF PIT TO FINAL GRADE SHALL NOT EXCEED 8"

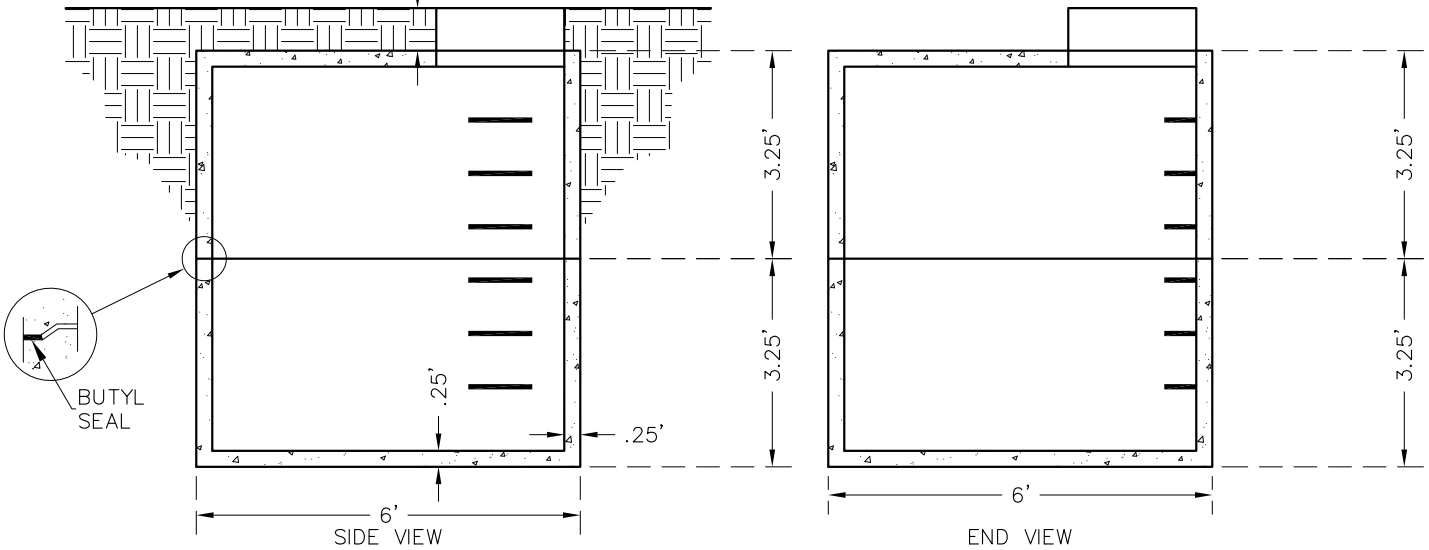

SIDE VIEW

END VIEW



CITY OF KALAMAZOO
Department Of Public Services

STANDARD METER PIT

RECOMMENDED BY _____

APPROVED BY _____

APPROVED BY _____

ACCEPTED BY _____

DATE

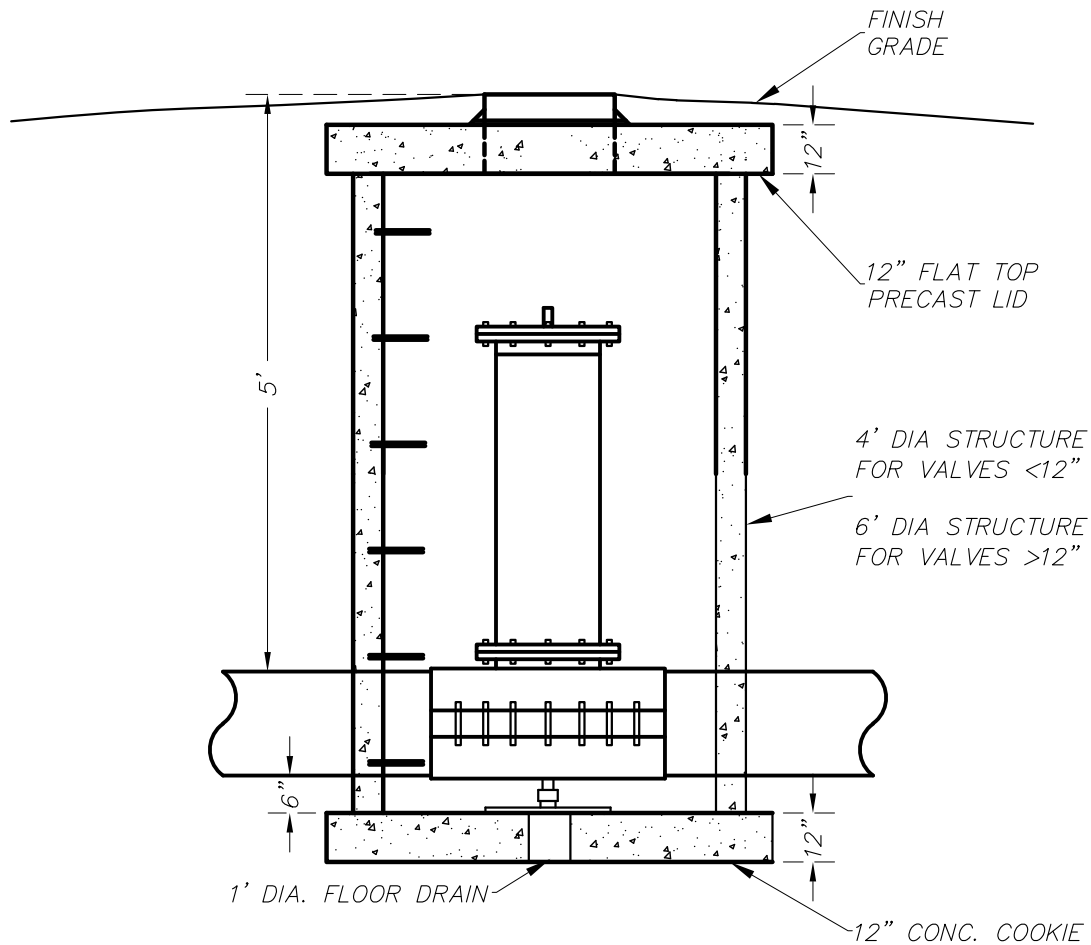
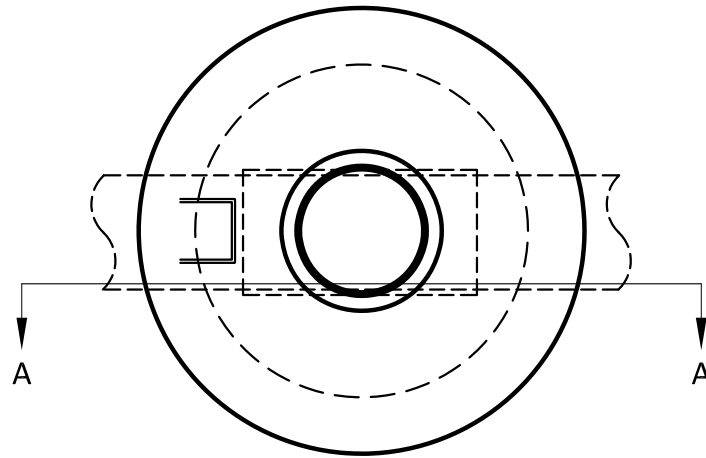

TYPICAL INSERTA – VALVE
PRECAST REINFORCED CONCRETE SHOWN



CITY OF KALAMAZOO
 Department Of Public Services

**INSERTA-VALVE
 STRUCTURE**

RECOMMENDED BY _____

APPROVED BY _____

APPROVED BY _____

ACCEPTED BY _____

DATE

NOTES:

1. METER VAULT (PIT) DESIGN MUST BE SUBMITTED AND APPROVED FOR EACH INDIVIDUAL INSTALLATION. DESIGN SHALL CONFORM TO THE CITY OF KALAMAZOO STANDARD SPECIFICATIONS FOR WATER MAIN AND SERVICE INSTALLATION LATEST REVISION.
2. THE DISTANCE BETWEEN RUNGS, CLEATS & STEPS SHALL NOT EXCEED 12 INCHES AND SHALL BE UNIFORM THROUGHOUT THE LENGTH OF THE LADDER.
3. CURB BOX WILL BE INSTALLED AT THE WATER MAIN.
4. COVER FOR METER PIT & CURB BOX SHALL BE INSTALLED & MAINTAINED LEVEL WITH THE ADJACENT GROUND.

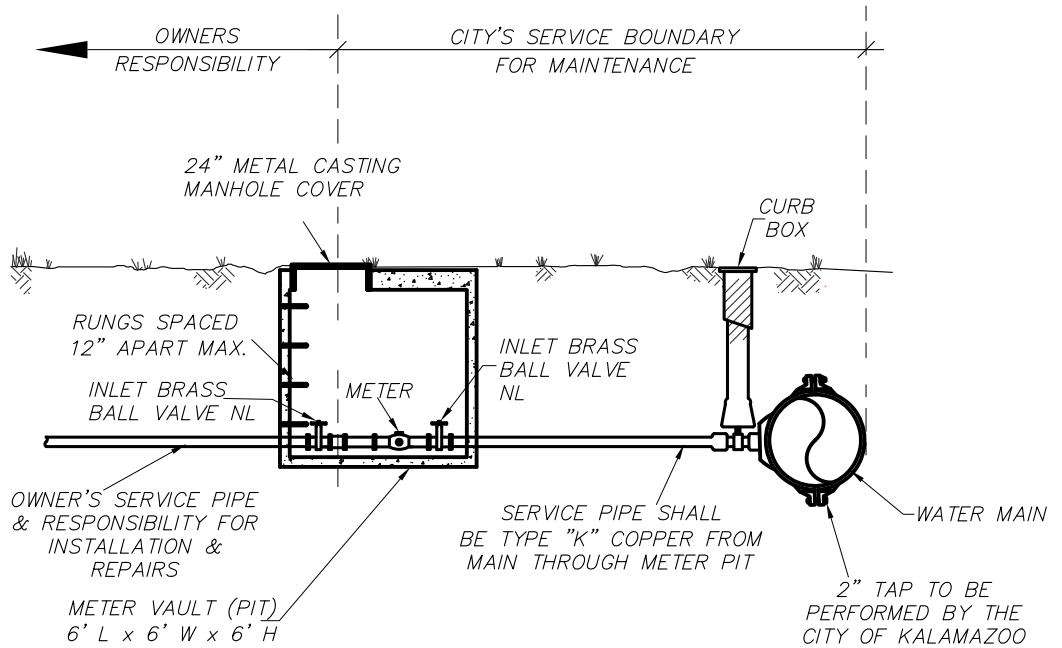

CITY OF KALAMAZOO
Department Of Public Services

**2" SERVICE LINE
METER VAULT**

RECOMMENDED BY _____

APPROVED BY _____

APPROVED BY _____

ACCEPTED BY _____

DATE

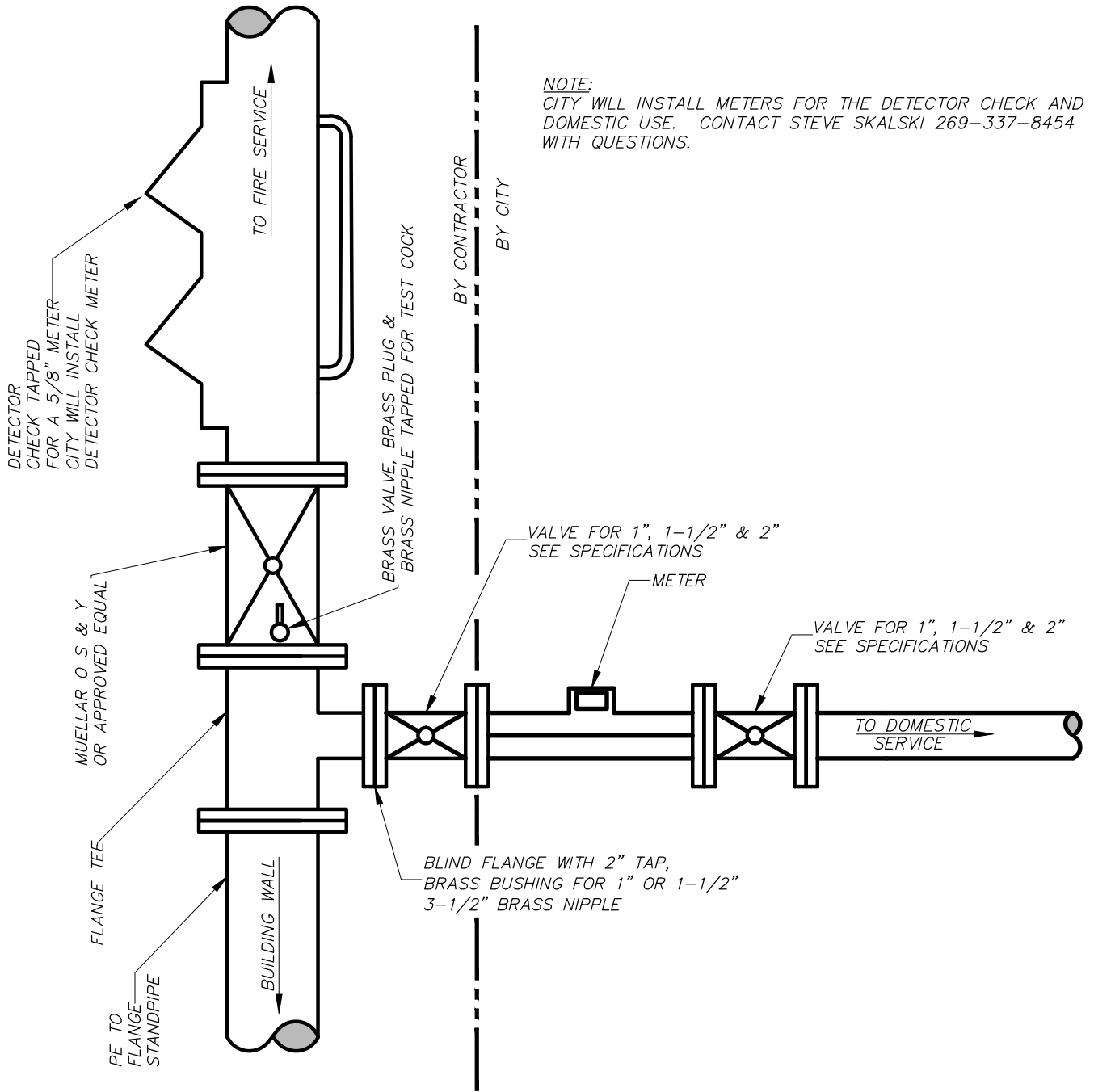

NOTE:
 CITY WILL INSTALL METERS FOR THE DETECTOR CHECK AND DOMESTIC USE. CONTACT STEVE SKALSKI 269-337-8454 WITH QUESTIONS.

BY CONTRACTOR
 BY CITY

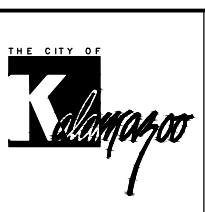

CITY OF KALAMAZOO
 Department Of Public Services
**TYPICAL FIRE SERVICE
 DETAIL**
 1" 1-1/2" 2"

RECOMMENDED BY _____	DATE _____
APPROVED BY _____	
APPROVED BY _____	
ACCEPTED BY _____	

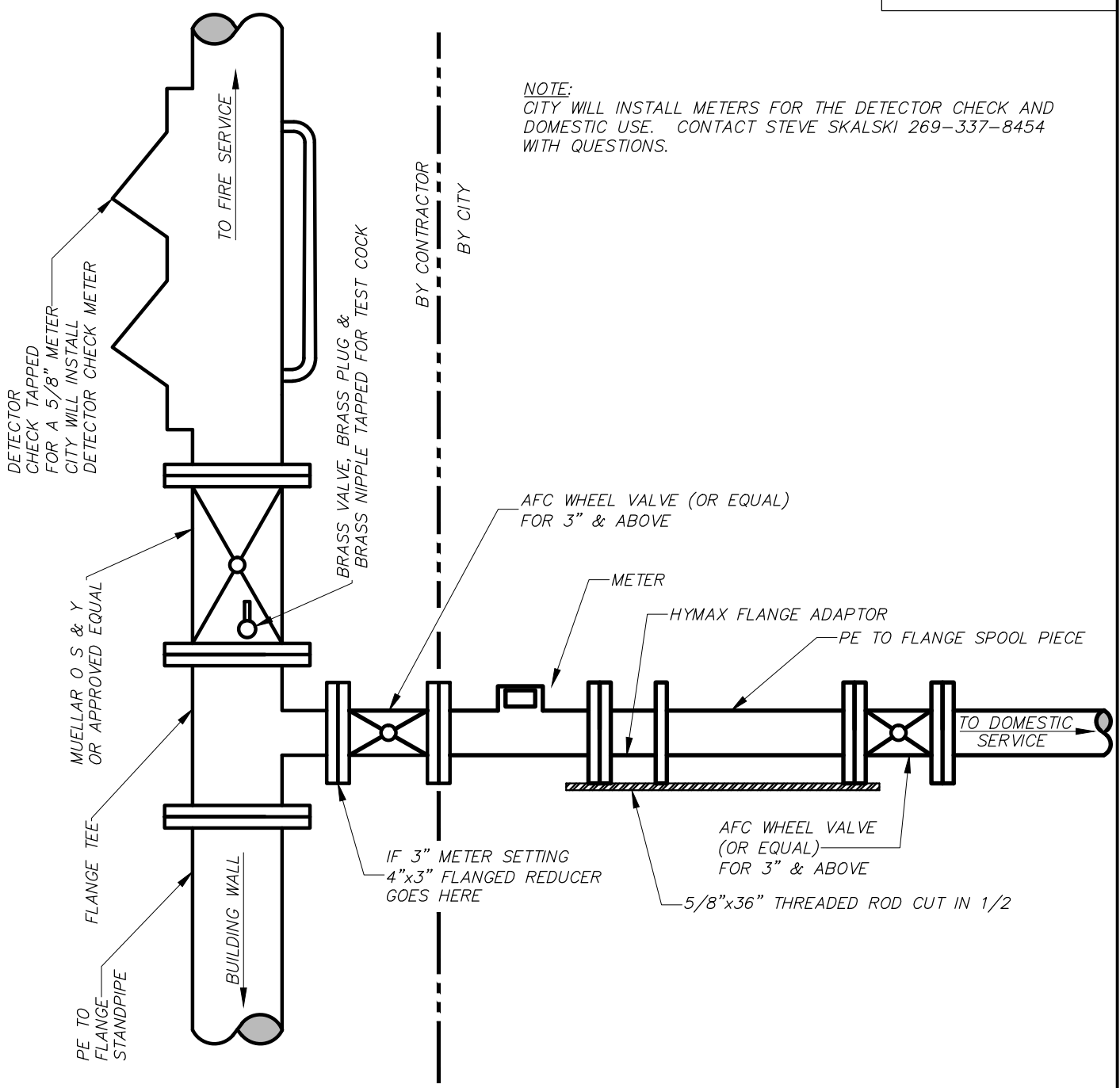

CITY OF KALAMAZOO
Department Of Public Services
**TYPICAL FIRE SERVICE
DETAIL**
3" 4" 6"

RECOMMENDED BY _____	DATE _____
APPROVED BY _____	
APPROVED BY _____	
ACCEPTED BY _____	

NOTES:

1. PLACEMENT OF STOP BOX CAN VARY FROM A MAXIMUM OF 5 FEET OUTSIDE THE PROPERTY LINE TO A MAXIMUM OF 5 FEET INSIDE THE PROPERTY LINE. PLACEMENT OF THE STOP BOX OUTSIDE THE PROPERTY LINE IS PREFERRED.
2. CITY WATER WILL REPAIR LEAKS ON SERVICE LINES WHEN NOTIFIED, FROM THE CORPORATION STOP TO METER.

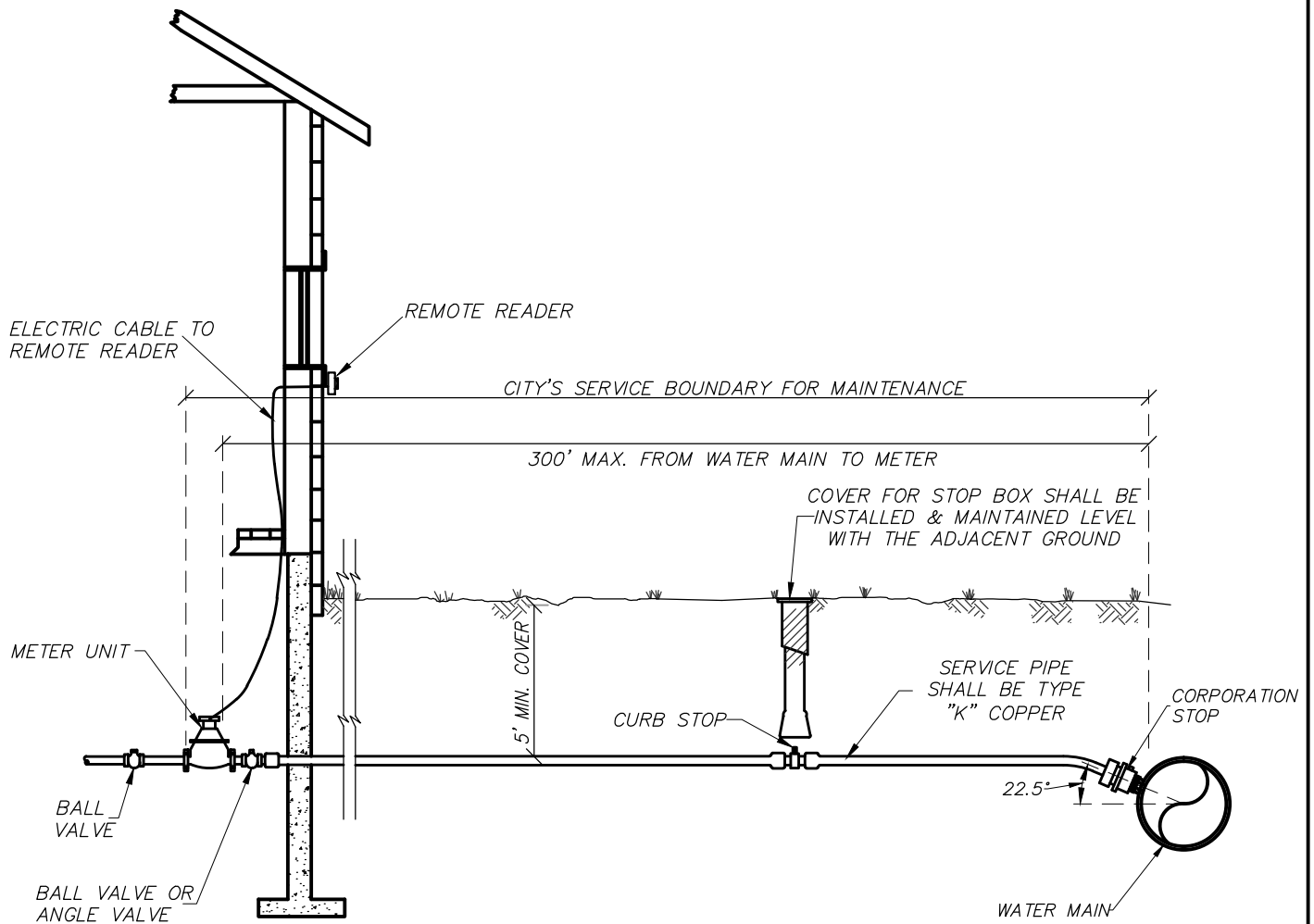

9/15/2015 1:27:03 PM



CITY OF KALAMAZOO
Department Of Public Services

**SERVICE LINE, STOP BOX AND
INSIDE METER INSTALLATION
1-1/4" SERVICE & 1" METER**

	DATE
RECOMMENDED BY _____	
APPROVED BY _____	
APPROVED BY _____	
ACCEPTED BY _____	

NOTES:

PLACEMENT OF STOP BOX CAN VARY FROM A MAXIMUM OF 5 FOOT OUTSIDE THE PROPERTY LINE TO A MAXIMUM OF 5 FOOT INSIDE THE PROPERTY LINE TO AVOID SIDEWALK. PLACEMENT OF STOP BOX OUTSIDE THE PROPERTY LINE IS PREFERRED.

OWNER'S RESPONSIBILITY SHALL BE UP TO 5 FEET FROM THE METER PIT CUSTOMER SIDE.

WATER DEPARTMENT'S RESPONSIBILITY SHALL BE THE WATER MAIN, THE CORPORATION STOP AND SERVICE PIPING UP TO 5 FEET FROM THE METER

METER PIT AND COVER SHALL BE THE RESPONSIBILITY OF THE OWNER.

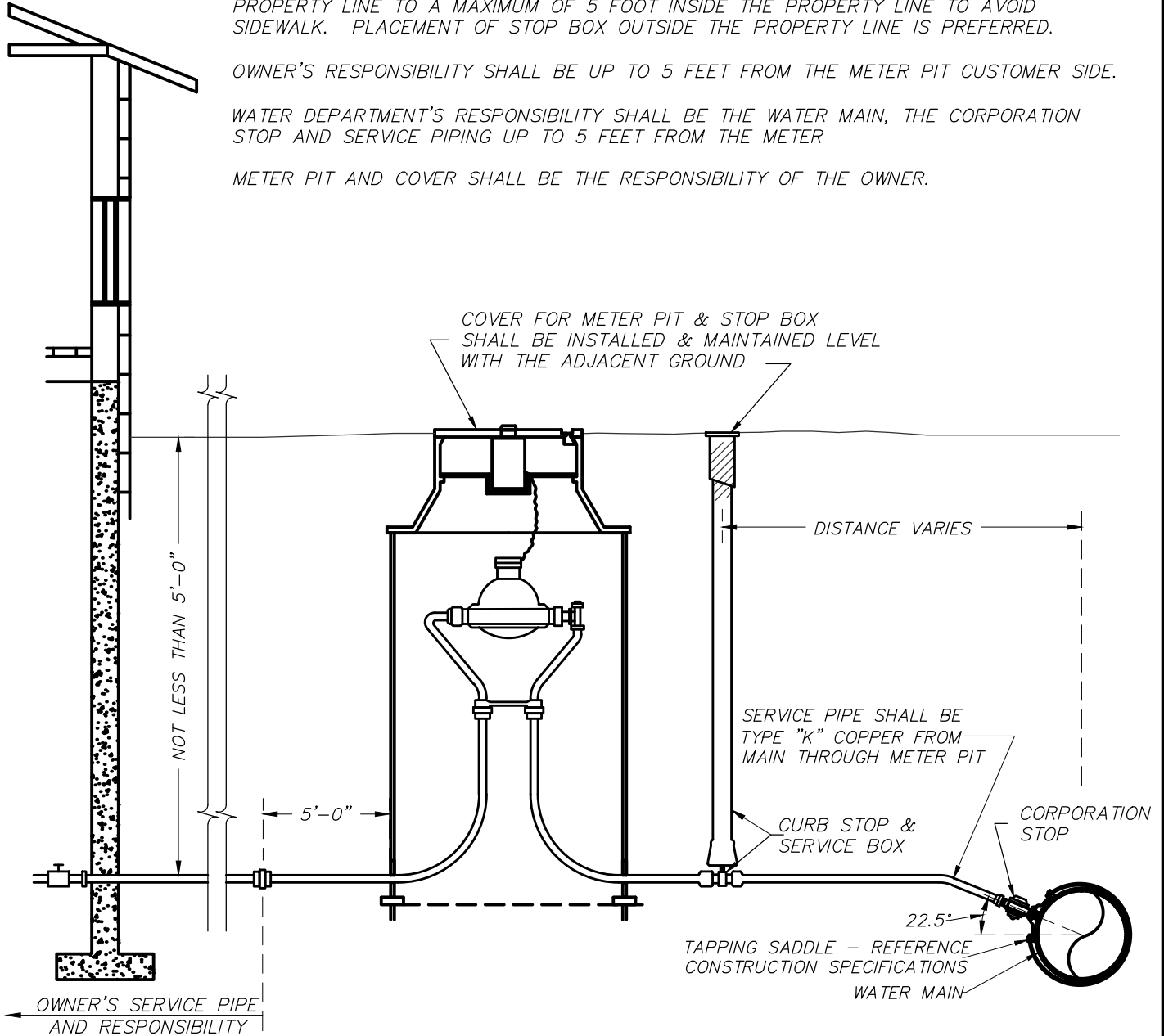

9/15/2015 12:06:36 PM



CITY OF KALAMAZOO
Department Of Public Services

**1-1/4" SERVICE LINE,
STOP BOX AND OUTSIDE
METER INSTALLATION**

RECOMMENDED BY _____	DATE
APPROVED BY _____	
APPROVED BY _____	
ACCEPTED BY _____	

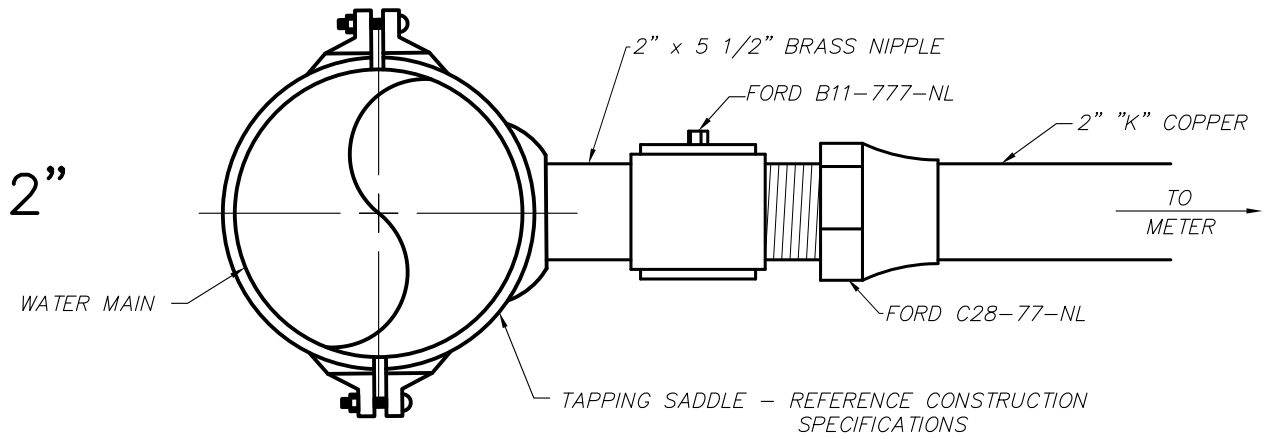
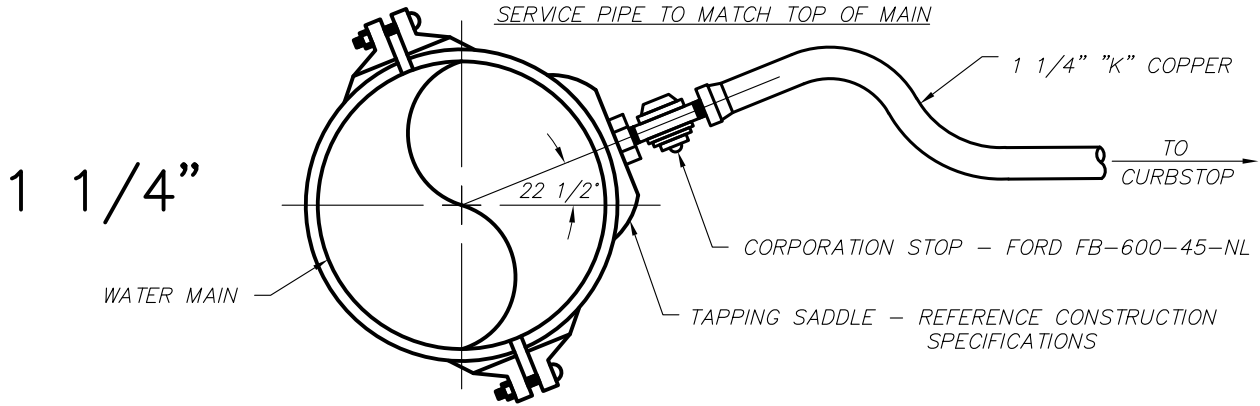

CITY OF KALAMAZOO
Department Of Public Services

**WATER SERVICE
TAPPING SLEEVE**

RECOMMENDED BY _____

APPROVED BY _____

APPROVED BY _____

ACCEPTED BY _____

DATE

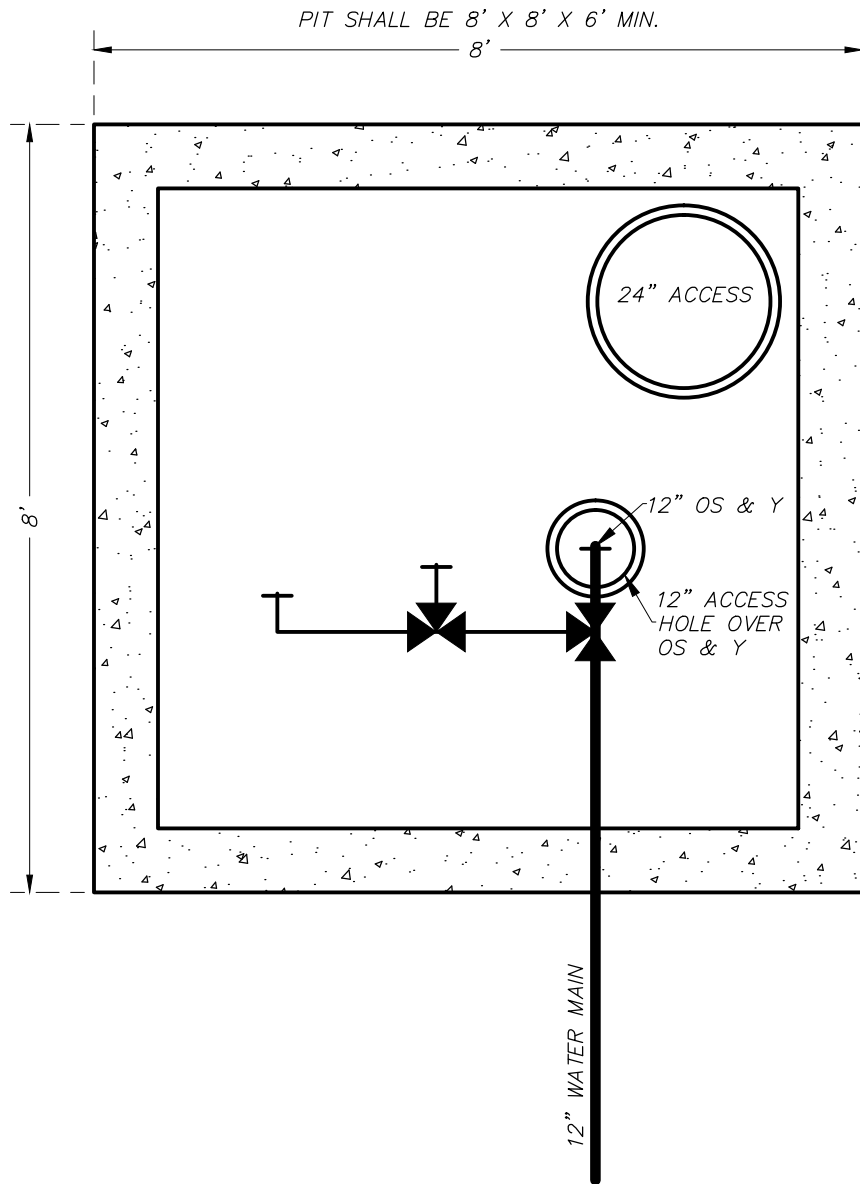

CITY OF KALAMAZOO
Department Of Public Services

12 INCH METER PIT

	DATE
RECOMMENDED BY _____	
APPROVED BY _____	
APPROVED BY _____	
ACCEPTED BY _____	

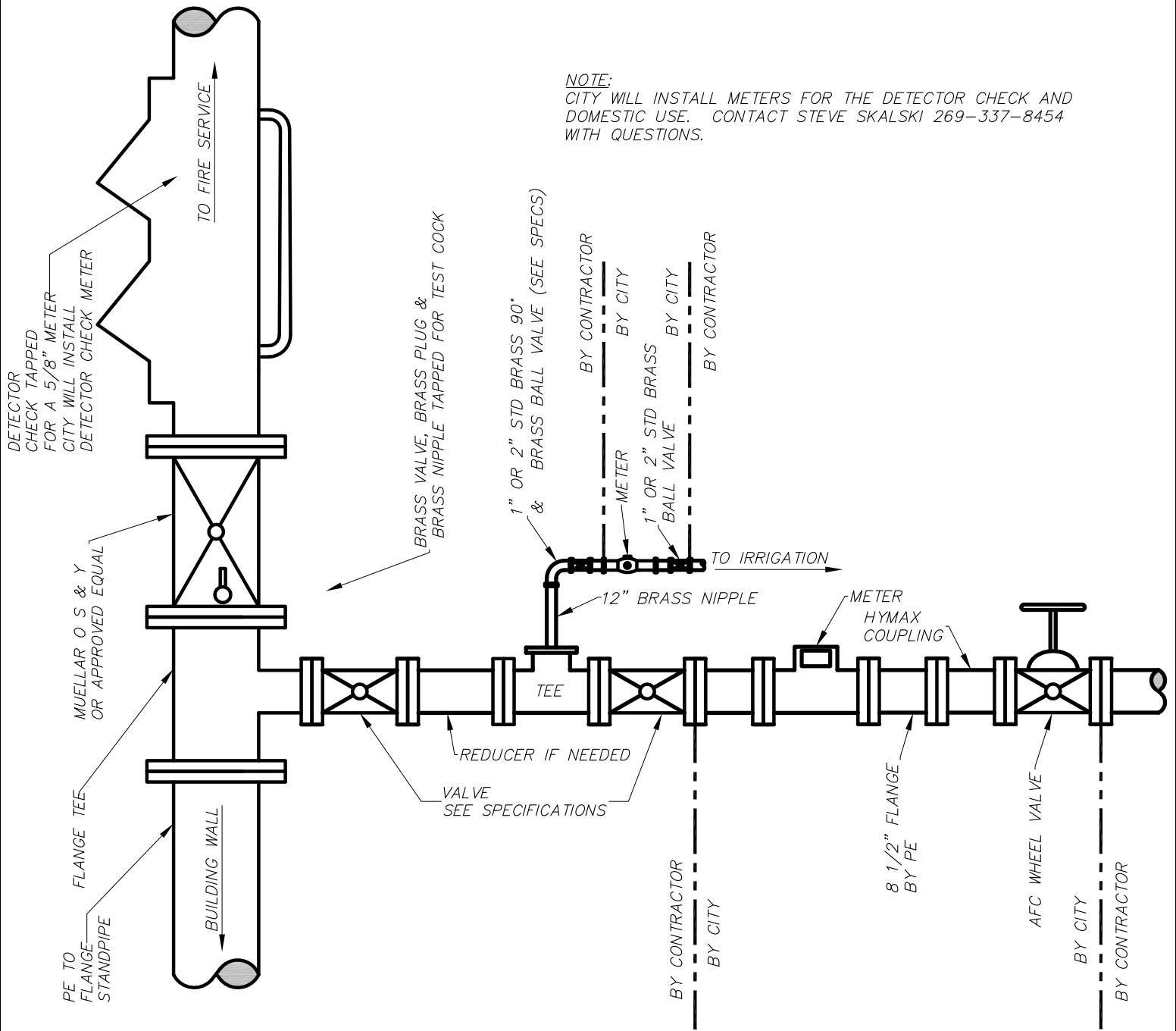

NOTE:
CITY WILL INSTALL METERS FOR THE DETECTOR CHECK AND DOMESTIC USE. CONTACT STEVE SKALSKI 269-337-8454 WITH QUESTIONS.



**TYPICAL FIRE SERVICE
DETAIL, DOMESTIC 3", 4",
& 6" & IRRIGATION 1" OR
2" VERTICAL SETTING**

RECOMMENDED BY _____

APPROVED BY _____

APPROVED BY _____

ACCEPTED BY _____

DATE

NOTE:
 CITY WILL INSTALL METERS FOR THE DETECTOR CHECK AND
 DOMESTIC USE. CONTACT STEVE SKALSKI 269-337-8454
 WITH QUESTIONS.

1" OR 2" STD. 90°
 W/1" OR 2" BRASS BALL VALVE
 OR FORD ANGLE VALVE
 (FV13-777W-NL) 2"
 (KV13-444W-NL) 1"

1" OR 2" X 12" BRASS NIPPLE

VALVE
 SEE SPECIFICATIONS

REDUCER
 (IF NEEDED)

TEE

TEE

PE TO
 FLANGE
 STANDPIPE

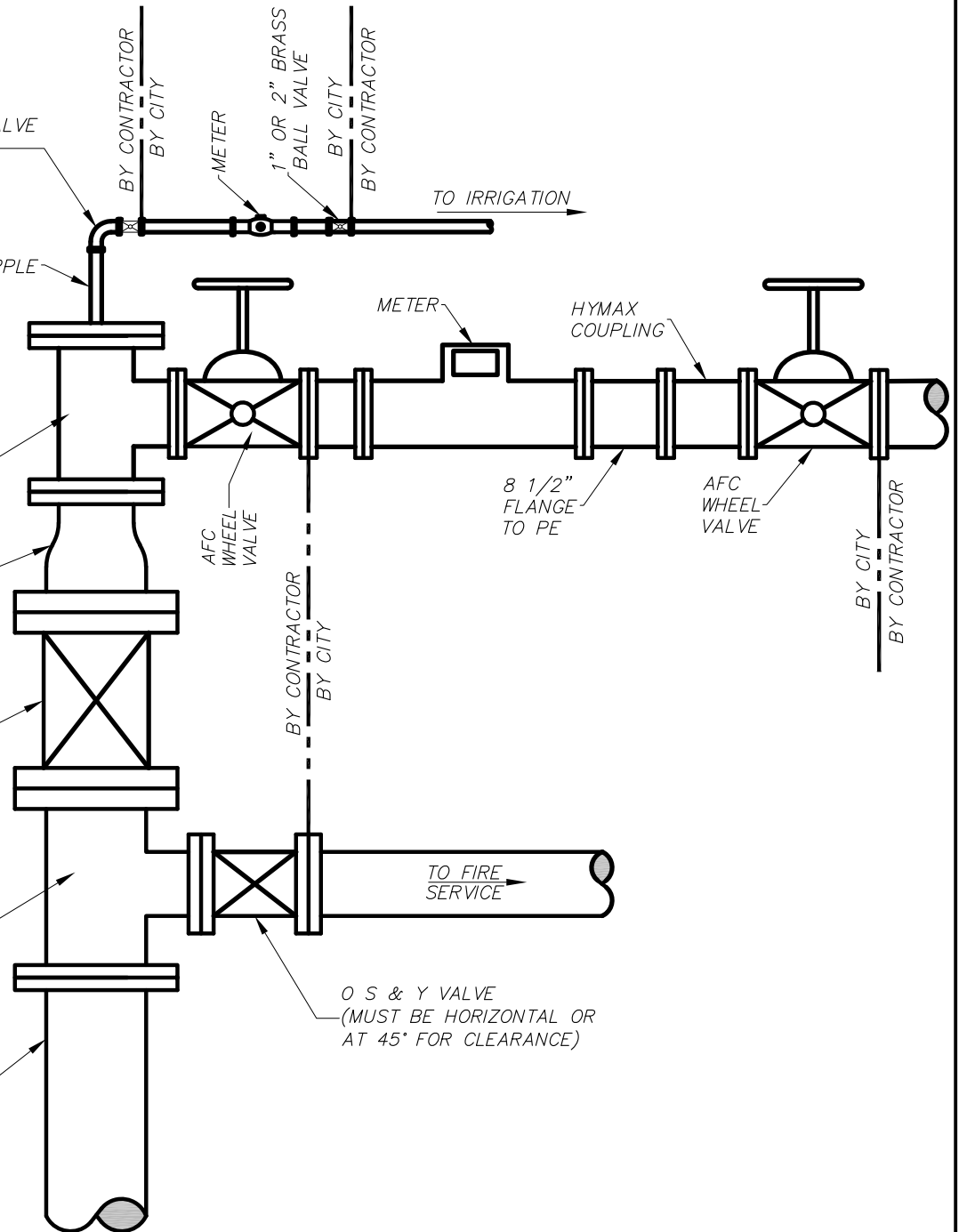

TO IRRIGATION

8 1/2"
 FLANGE
 TO PE

TO FIRE
 SERVICE

O S & Y VALVE
 (MUST BE HORIZONTAL OR
 AT 45° FOR CLEARANCE)



CITY OF KALAMAZOO
 Department Of Public Services
TYPICAL FIRE SERVICE DETAIL
HORIZONTAL SETTING
W/3", 4", OR 6" DOMESTIC
& 1" OR 2" IRRIGATION

RECOMMENDED BY _____	DATE _____
APPROVED BY _____	
APPROVED BY _____	
ACCEPTED BY _____	

NOTE:
 CITY WILL INSTALL METERS FOR THE DETECTOR CHECK AND
 DOMESTIC USE. CONTACT STEVE SKALSKI 269-337-8454
 WITH QUESTIONS.

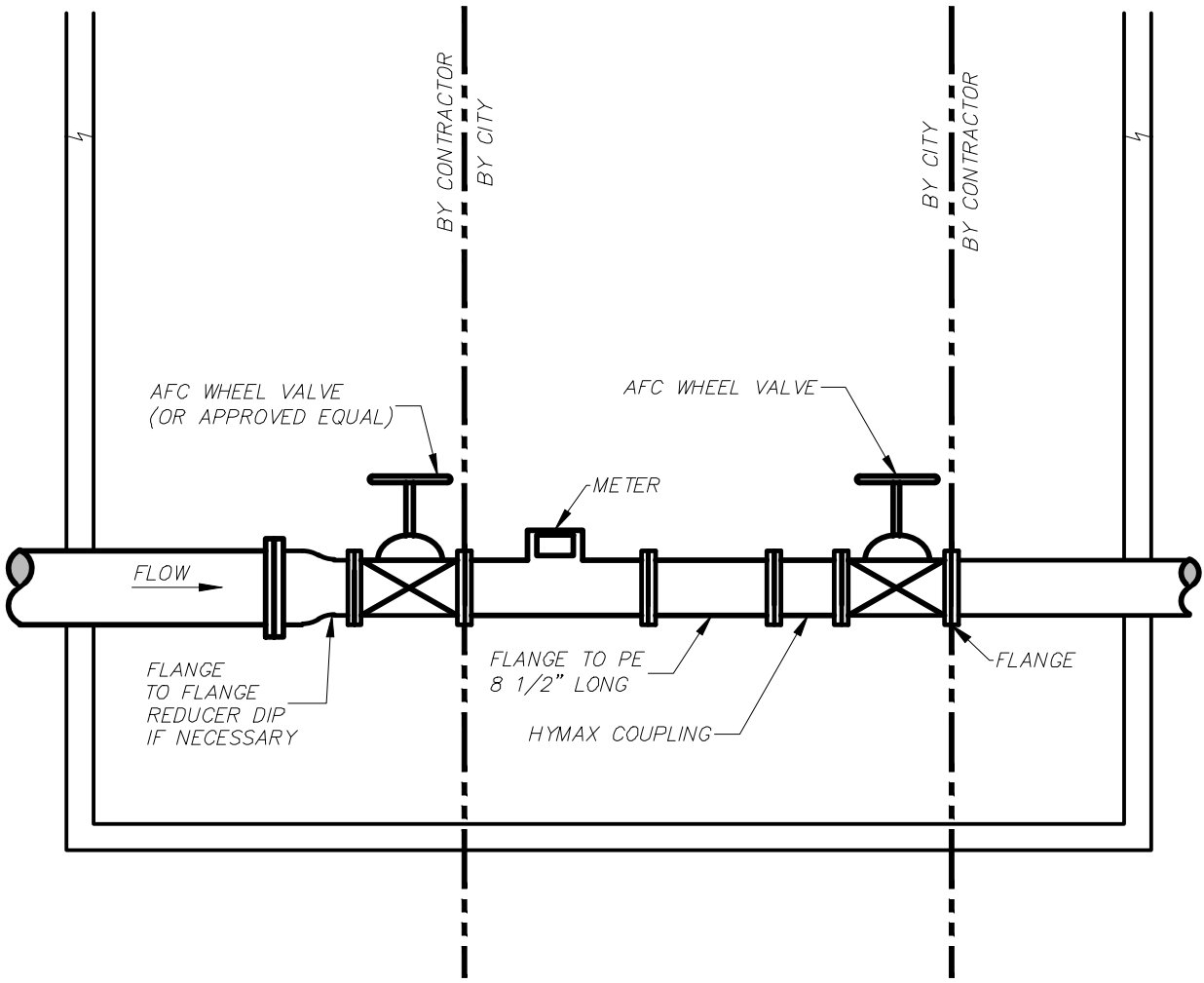

CITY OF KALAMAZOO
 Department Of Public Services
**PIT METER SETTING
 DETAIL FOR
 3", 4", 6" & 8"**

RECOMMENDED BY _____	DATE _____
APPROVED BY _____	
APPROVED BY _____	
ACCEPTED BY _____	

NOTE:
CITY WILL INSTALL METERS FOR THE DETECTOR CHECK AND DOMESTIC USE. CONTACT STEVE SKALSKI 269-337-8454 WITH QUESTIONS.

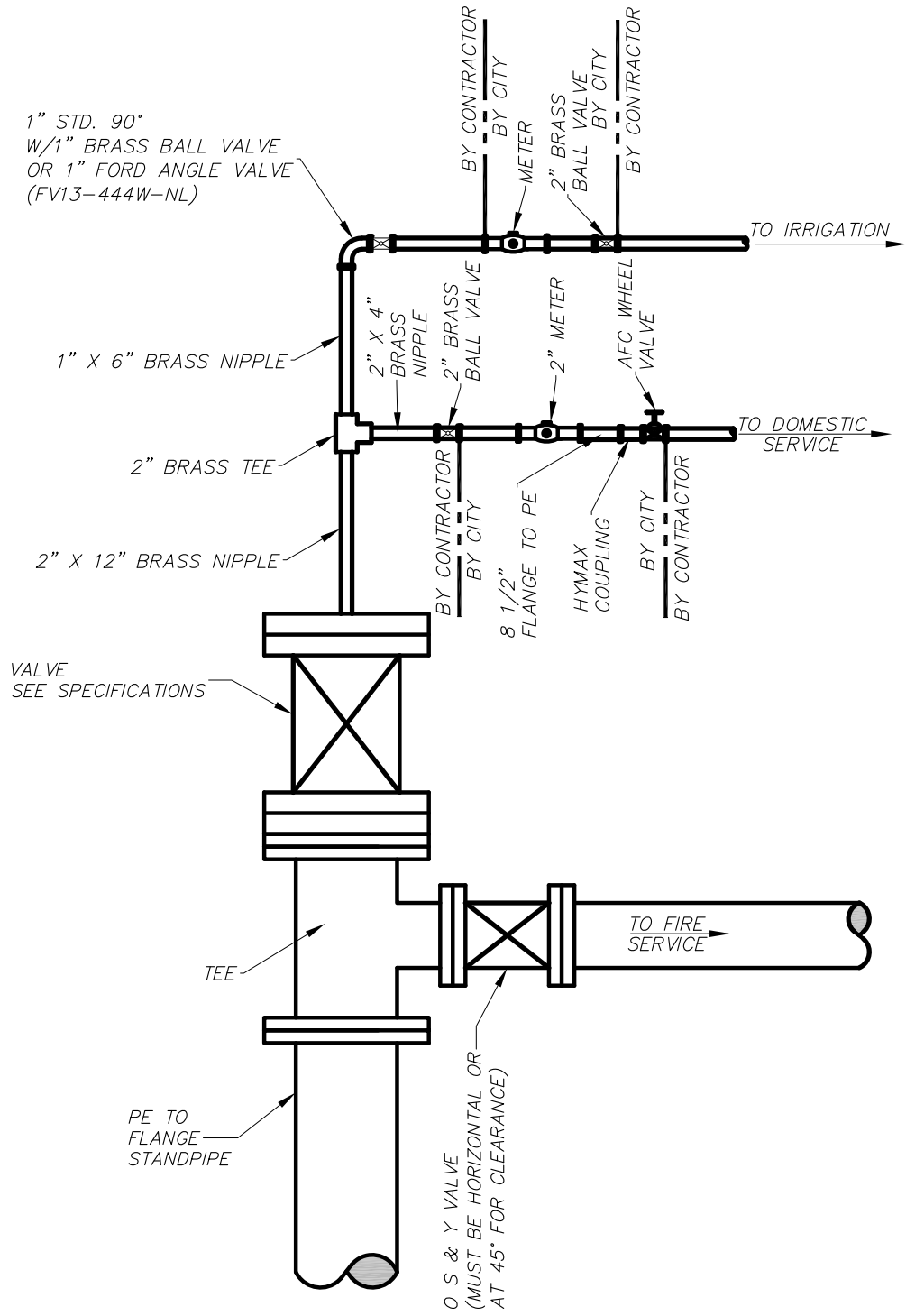

	CITY OF KALAMAZOO Department Of Public Services	RECOMMENDED BY _____	DATE
	TYPICAL FIRE SERVICE DETAIL HORIZONTAL SETTING 2" DOMESTIC 1" IRRIGATION	APPROVED BY _____	
		APPROVED BY _____	
		ACCEPTED BY _____	

NOTE:
 CITY WILL INSTALL METERS FOR THE DETECTOR CHECK AND
 DOMESTIC USE. CONTACT STEVE SKALSKI 269-337-8454
 WITH QUESTIONS.

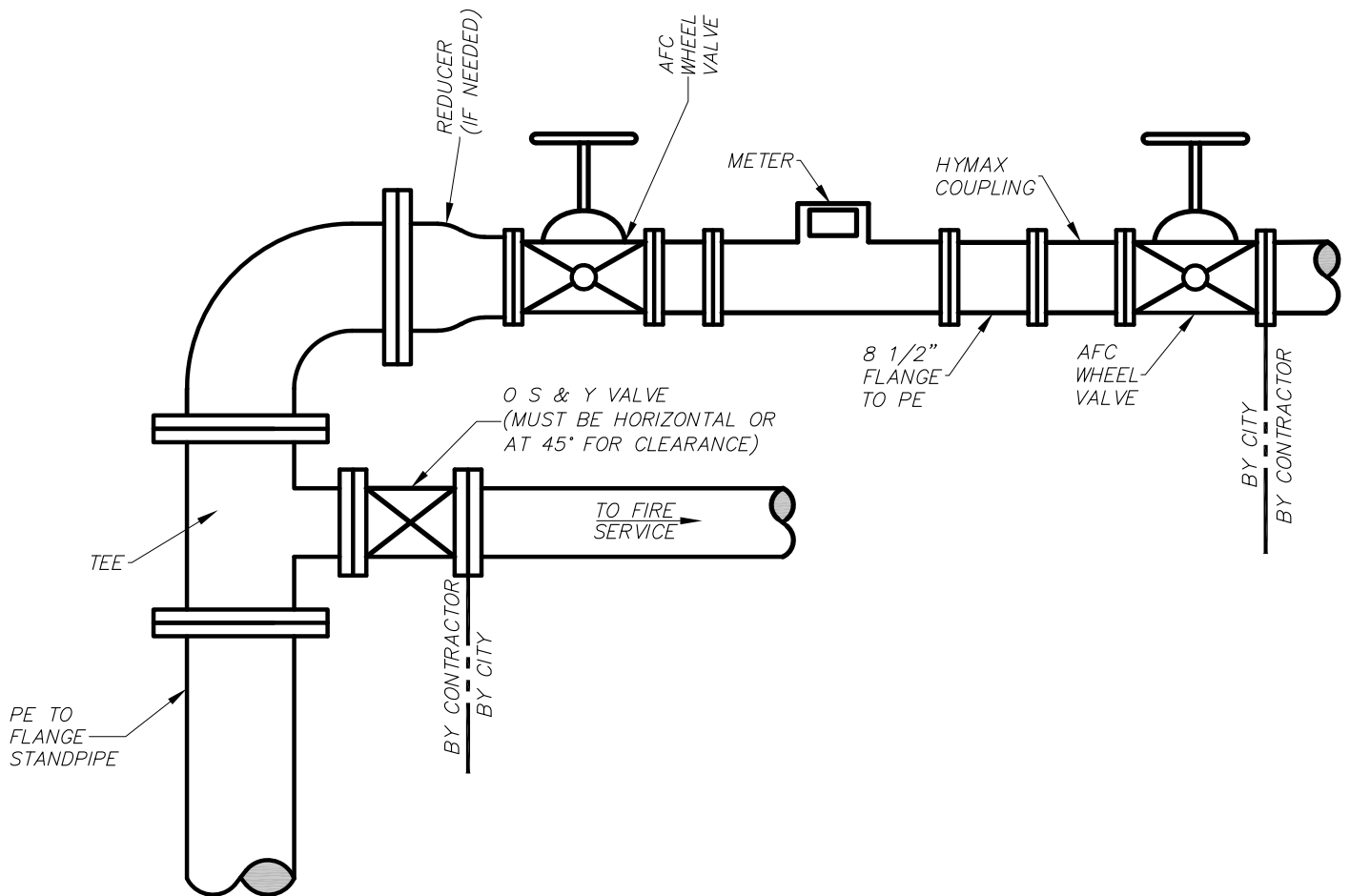

CITY OF KALAMAZOO
 Department Of Public Services

**TYPICAL FIRE SERVICE DETAIL
 HORIZONTAL SETTING
 W/3", 4", OR 6" DOMESTIC**

RECOMMENDED BY _____	DATE _____
APPROVED BY _____	
APPROVED BY _____	
ACCEPTED BY _____	

WS-16-A

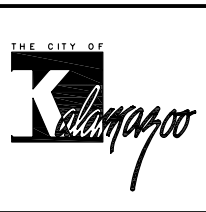
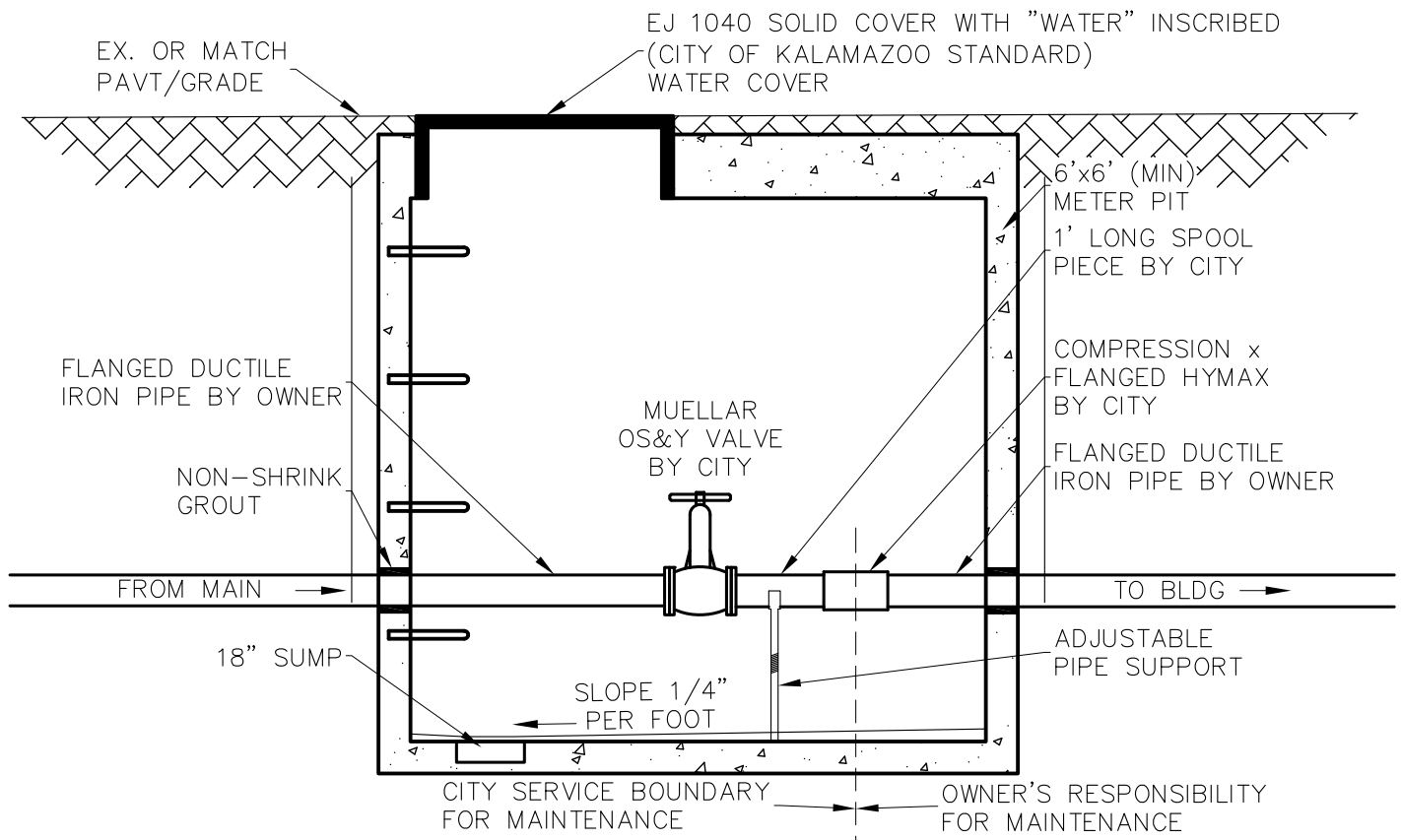
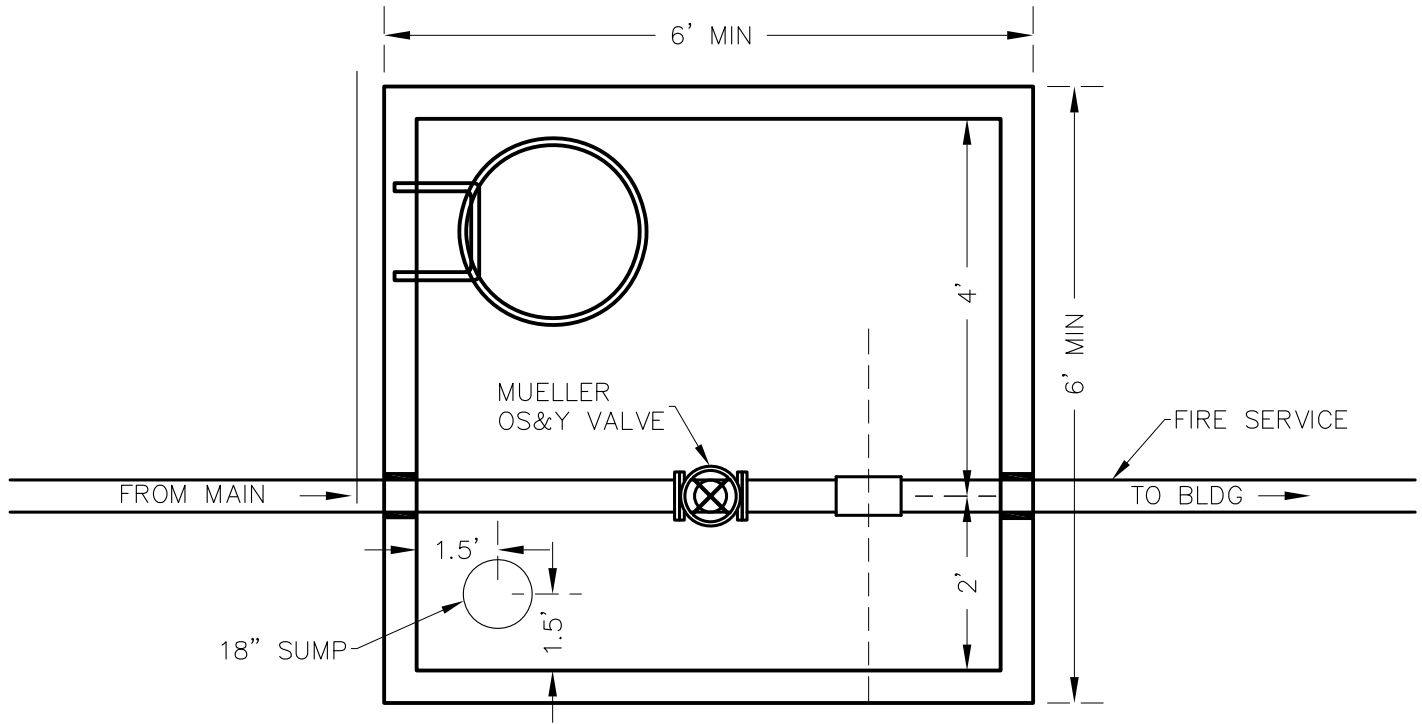

CITY OF KALAMAZOO
Department Of Public Services

**FIRE SERVICE
IN PIT DETAIL**

RECOMMENDED BY _____	DATE _____
APPROVED BY _____	
APPROVED BY _____	
ACCEPTED BY _____	

be considered incidental to other major items of work unless noted otherwise.

4.15.02 Water Main

Measurement of the length of the main will be in feet along the centerline of the main through any fittings along the length being measured and must include any joint restraint or polyethylene encasement required.

4.15.03 Hydrants

Hydrants will be measured as single units including all connective piping, joint restraint, fittings, and extensions required to bring the hydrant to proper grade. The cost of the branch pipe must be incidental to the cost of installing the hydrant.

4.15.04 Fittings

Fittings such as bends, tees, crosses, plugs, reducers, and sleeves will be measured as single units and must include any joint restraint required.

When no proposal item is provided, the work will be considered part of the major items of work.

4.15.05 Valves

Valves will be measured as single units and must include valve box, joint restraint, and other materials as required for installation of the valve and valve box.

4.15.06 Taps

Taps for either water valves or water services must be considered part of the major items of work and no specific payment will be made therefor unless otherwise provided for in the proposal.

4.15.07 Thrust Block

Thrust blocks will be measured as single units and must include removal of existing thrust blocks.

When no proposal item is provided, the work must be considered part of the major items of work.

4.15.08 Water Services

Measurement of the length of the service will be in feet along the centerline of the service through any fittings along the length being measured.

Corporation Stops will be measured in single units and include the tap of the water main.

Curb Stops will be measured in single units and include the stop box.



PLANS

BORN COURT WELL 1-7

Bid Reference #: 91244-044.0

May 2025

CITY OF KALAMAZOO
KALAMAZOO COUNTY, MICHIGAN

WATER SUPPLY SYSTEM IMPROVEMENTS
BORN COURT WELL 1-7

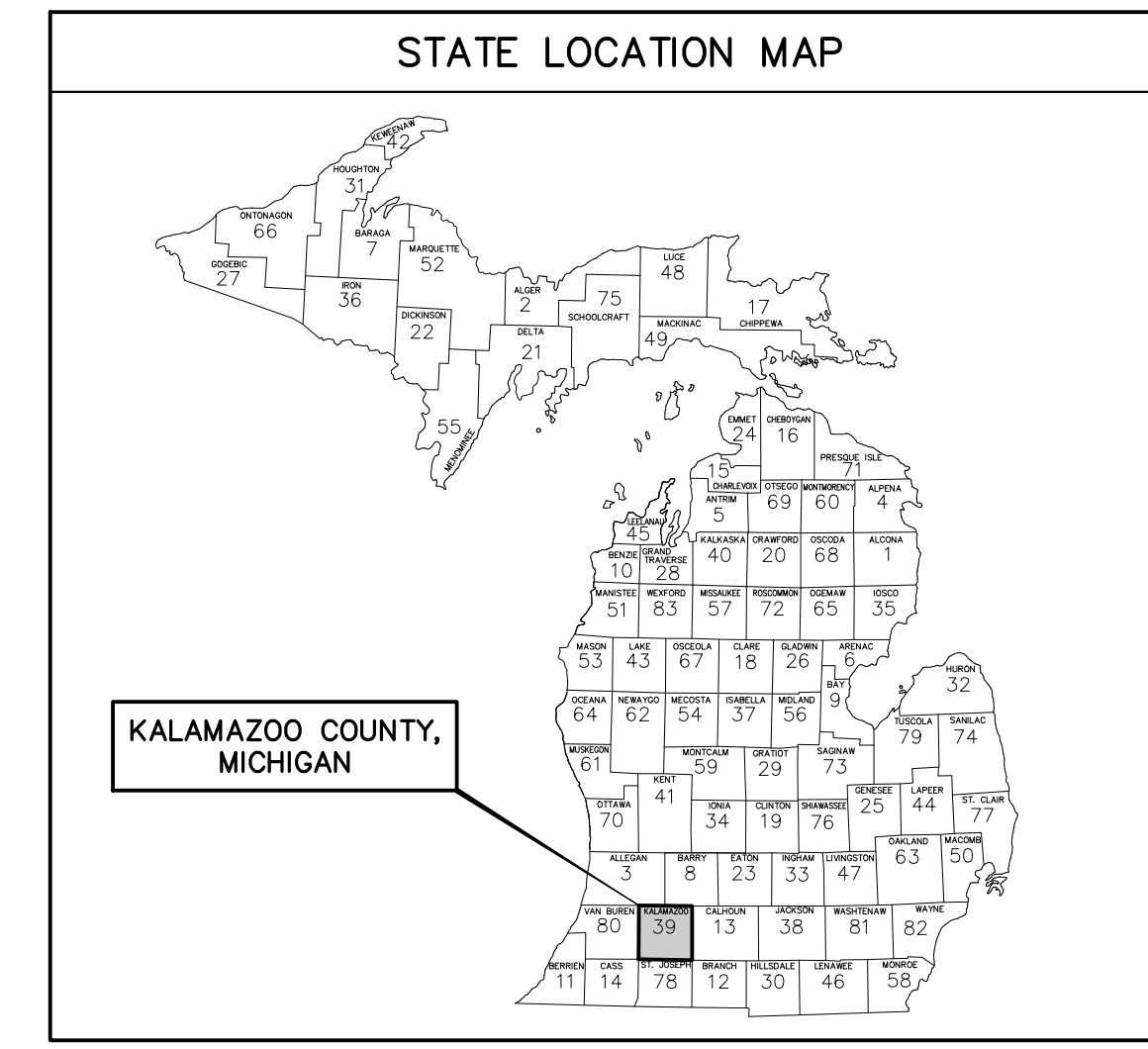
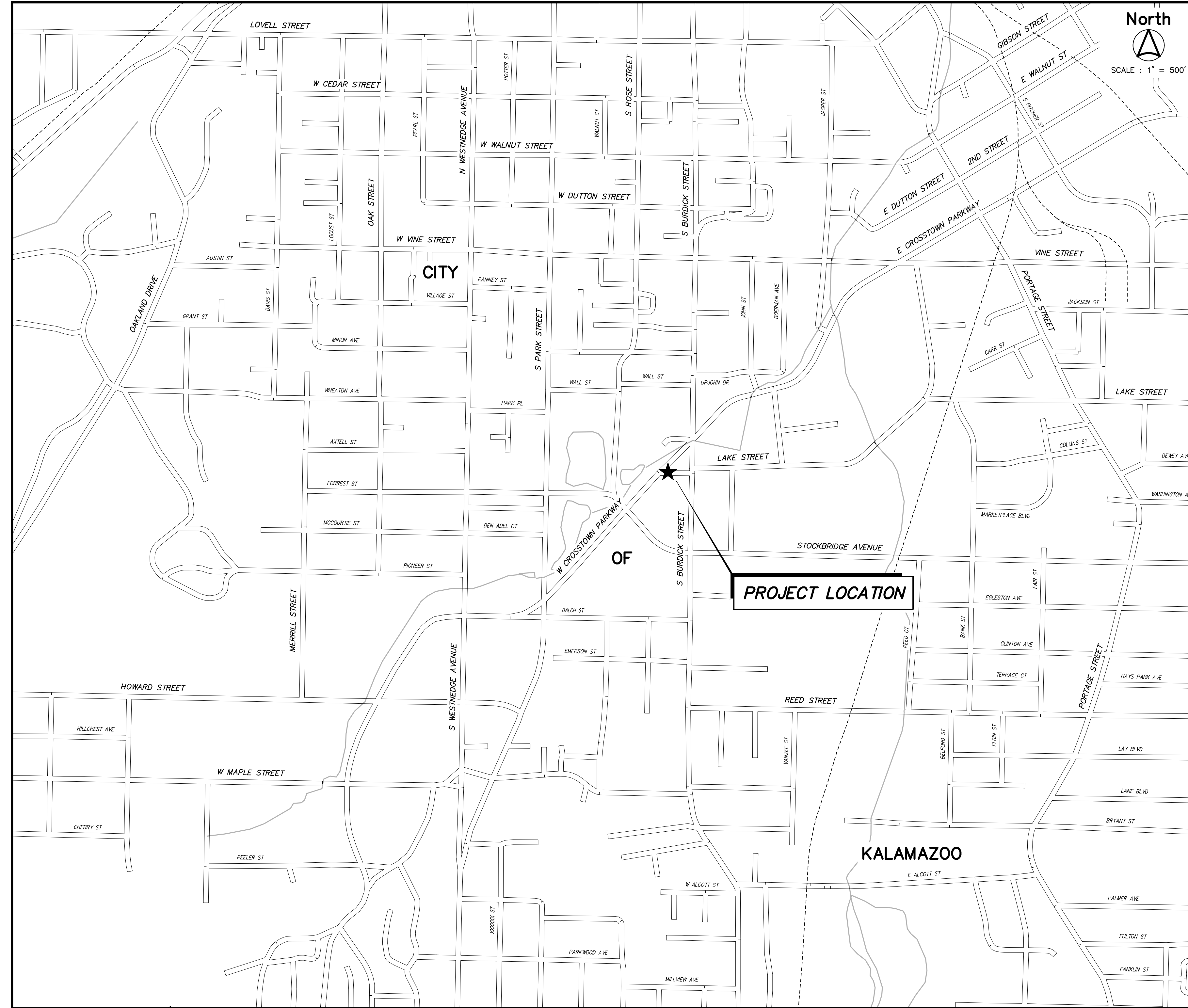

SOIL BORING GENERAL NOTES

WITHIN EACH SOIL BORING, WHERE SHOWN, SOIL SAMPLES WERE OBTAINED BY THE STANDARD PENETRATION TEST METHOD, ASTM D1586, WHEREBY A SPLIT-SPOON SAMPLER IS DRIVEN THREE SUCCESSIVE 6-INCH INCREMENTS WITH A 140 POUND WEIGHT FALLING 30 INCHES. THE NUMBER OF BLOWS REQUIRED TO DRIVE THE SAMPLER FOR EACH INCREMENT IS PRESENTED ON THE SOIL BORING LOGS.

GRANULAR SOILS (COARSE-GRAINED) HAVE MORE THAN 50% OF THEIR DRY WEIGHT RETAINED ON A #200 SEVE. THEY ARE DESCRIBED AS: BOULDERS, COBBLES, GRAVEL OR SAND. FINE-GRAINED SOILS HAVE LESS THAN 50% OF THEIR DRY WEIGHT RETAINED ON A #200 SEVE. THEY ARE DESCRIBED AS: CLAYS OR CLAYEY SILTS IF THEY ARE COHESIVE, AND SILTS IF THEY ARE NON-COHESIVE. IN ADDITION TO DRAINAGE, GRANULAR SOILS ARE DEFINED BASED ON THEIR IN-SITU DENSITY; FINE GRAINED SOILS ARE FURTHER DEFINED BASED ON THEIR STRENGTH OR CONSISTENCY, AND ON THEIR PLASTICITY.

MAJOR SOIL COMPONENT	GRADATION RANGE	DESCRIPTION TERMS (OF MINOR SOIL CONSTITUENTS)	PERCENT OF DRY WEIGHT
BOULDERS	OVER 12 INCHES (305mm)		1 - 10
COBBLES	12 INCHES TO 3 INCHES (305mm TO 76mm)	TRACE	10 - 20
GRAVEL COARSE	3 INCHES TO 3/4 INCHES (76mm TO 19mm)	LITTLE	20 - 35
GRAVEL FINE	3/4 INCHES TO #4 SEVE (19mm TO 4.75mm)	SOME	35 - 50
SAND COARSE	#4 SEVE TO #10 SEVE (4.75mm TO 2.00mm)	AND	
SAND MEDIUM	#10 SEVE TO #40 SEVE (2.00mm TO 0.425mm)		
SAND FINE	#40 SEVE TO #200 SEVE (0.425mm TO 0.075mm)		
SILT	PASSING #200 SEVE (0.075mm) TO 0.0075mm	CONSISTENCY OF COHESIVE SOILS:	
CLAY	SMALLER THAN 0.0075mm		

UNCOMPACTED COMP. STRENGTH, q_c (kg)	CONSISTENCY
<25	VERY SOFT
0.25 - 0.50	SOFT
0.50 - 1.00	MEDIUM (FRM)
1.00 - 2.00	STIFF
2.00 - 4.00	VERY STIFF
4.00 - 8.00	HARD
>8.00	VERY HARD

IN-SITU DENSITY OF GRANULAR SOILS

N - BLOWS/FT	IN-SITU DENSITY	CONSISTENCY
0 - 4	VERY LOOSE	VERY SOFT
5 - 10	LOOSE	SOFT
11 - 30	MEDIUM DENSE	MEDIUM (FRM)
31 - 50	DENSE	VERY STIFF
50 +	VERY DENSE	HARD

WATER LEVELS INDICATED ON THE BORING LOGS ARE THE LEVELS MEASURED IN THE BORING AT THE TIMES INDICATED. IT SHOULD BE NOTED THAT GROUNDWATER LEVELS OBSERVED DURING DRILLING IN PREDOMINANTLY COHESIVE SOILS ARE NOT NECESSARILY INDICATIVE OF THE STATIC GROUNDWATER LEVEL. THIS IS DUE TO THE RELATIVELY LOW PERMEABILITY OF CLAY SOILS AND THE TENDENCY OF DRILLING OPERATIONS TO TEMPORARILY SEAL OFF NATURAL PATHS OF GROUNDWATER MOTION INTO THE BORING. ADDITIONALLY, FLUCTUATIONS IN GROUNDWATER LEVELS SHOULD BE ANTICIPATED WITH SEASONAL VARIATIONS AND FOLLOWING PERIODS OF HEAVY OR PROLONGED PRECIPITATION.

THE SOIL BORING LOGS SHOWN ON THE CONSTRUCTION PLANS ARE BEING FURNISHED FOR YOUR CONVENIENCE AND GENERAL INFORMATION ONLY. THE DATA SHOWN ON THE BORING LOGS REPRESENTS TEST AND GROUNDWATER CONDITIONS ENCOUNTERED AT THE RESPECTIVE BORING LOCATIONS. VARIATIONS MAY OCCUR BETWEEN THESE LOCATIONS. ADDITIONALLY, THE STRATIGRAPHIC LINES REPRESENT THE APPROXIMATE BOUNDARIES BETWEEN SOIL TYPES. HOWEVER, THE TRANSITION MAY BE MORE GRADUAL THAN WHAT IS SHOWN. THE BINDER WILL BE RESPONSIBLE FOR MAKING THEMSELVES FAMILIAR WITH SURFACE CONDITIONS BY WHATEVER MEANS THEY DEEM NECESSARY AND SHALL MAKE THEIR OWN DETERMINATIONS THEREON.

THE BINDER BY SUBMITTING A BID, WAIVES ALL CLAIMS FOR DAMAGES WHICH THEY MAY SUFFER BY REASON OF THE INADEQUACIES OR DISCREPANCIES OF THE INFORMATION SHOWN ON THESE SOIL BORING LOGS AND UNDERSTANDS THAT NO COMPENSATION WILL BE PAID TO THEM DUE TO AN INADEQUACY OR DISCREPANCY IN THIS DATA.

- GENERAL NOTES**
- THE IMPROVEMENTS COVERED BY THESE PLANS SHALL BE DONE IN ACCORDANCE WITH THE 2012 MICHIGAN DEPARTMENT OF TRANSPORTATION'S STANDARD SPECIFICATIONS FOR CONSTRUCTION EXCEPT WHERE OTHERWISE INDICATED ON THESE PLANS. IN THE PROPOSAL, SUPPLEMENTAL SPECIFICATIONS, OR SPECIAL PROVISIONS FOR THIS PROJECT.
 - CONTRACTOR TO CALL MISS DIG (CALL TOLL FREE 1-800-482-7171) OR 811 THREE WORKING DAYS BEFORE STARTING YOUR PROJECT. (EXCLUDING WEEKENDS AND HOLIDAYS)
 - THE IMPROVEMENTS COVERED BY THESE PLANS SHALL BE IN DONE IN ACCORDANCE WITH THE 2011 MICHIGAN MANUAL OF UNIFORM TRAFFIC CONTROL DEVICES.
 - ALL WORK SHALL BE COMPLETED IN ACCORDANCE WITH THE CITY OF KALAMAZOO STANDARD SPECIFICATIONS FOR WATER MAIN AND SERVICE INSTALLATION 2021.

UTILITIES

<p>WATER & SANITARY CITY OF KALAMAZOO 415 STOCKBRIDGE AVE KALAMAZOO, MI 49001 PHONE: (269) 337-8558 ATTN: DEBBIE JUNG</p> <p>STORM SEWER CITY OF KALAMAZOO 415 E STOCKBRIDGE AVENUE KALAMAZOO, MI 49001 PHONE: (269) 337-8697 ATTN: TOM PALUMBO</p> <p>GAS CONSUMERS ENERGY 2500 E CORK ST KALAMAZOO, MI 49001 PHONE: (269) 337-2366 ATTN: KYLE OAK</p>	<p>ELECTRIC-DISTRIBUTION CONSUMERS ENERGY 2500 E CORK ST KALAMAZOO, MI 49001 PHONE: (269) 337-2245 ATTN: ANDRE TAYLOR</p> <p>FIBER OPTIC CHARTER SPECTRUM 4176 COMMERCIAL AVE KALAMAZOO, MI 49002 PHONE: (269) 207-9648 ATTN: JASON TILLER</p> <p>CABLE TELEVISION CHARTER SPECTRUM 4176 COMMERCIAL AVE KALAMAZOO, MI 49002 PHONE: (269) 207-9648 ATTN: JASON TILLER</p>
--	---

UTILITY LOCATIONS ARE DERIVED FROM ACTUAL MEASUREMENTS OR AVAILABLE RECORDS. THEY SHOULD NOT BE INTERPRETED TO BE EXACT LOCATIONS NOR SHOULD IT BE ASSUMED THAT THEY ARE THE ONLY UTILITIES IN THIS AREA.

811
Know what's below.
Call before you dig.

PROJECT DATUM INFORMATION

COORDINATE SYSTEM : STATE PLANE GRID
ZONE : MICHIGAN SOUTH 2113
ELLIPSOID : GRS 80
HORIZONTAL DATUM : NAD 83 (2011)
VERTICAL DATUM : NAVD 88
GEOID : GEOID 18
UNITS : INTERNATIONAL FEET

PROJECT COMBINED SCALE FACTOR (PCSF) = 0.999962554581
GROUND DISTANCE = GRID DISTANCE/PCSF

APPROVED BY:
THE CITY OF KALAMAZOO

John Randall
DATE: 05/16/2025

DEPARTMENT OF PUBLIC SERVICES
ASSISTANT CITY ENGINEER

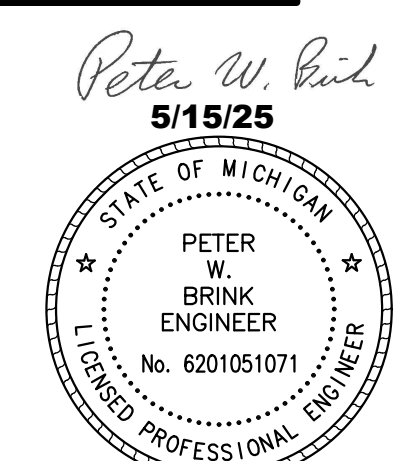

SHEET INDEX

SHEET No.	DESCRIPTION
1	COVER SHEET
2	EXISTING SITE PLAN
3	PROPOSED SITE & YARD PIPING PLAN
4	ELECTRICAL SITE PLAN
5	ELECTRICAL POWER PLAN
6	ELECTRICAL SITE PLAN & DETAILS
7	ELECTRICAL WRING DIAGRAM
8	ELECTRICAL SINGLE-LINE DIAGRAM

Prein&Newhof
Engineers • Surveyors • Environmental • Laboratory

PROJECT NO.
2220555

SHEET NO.
1 OF 8

T:\0\130 PROJECTS\2022\2220555_CITY OF KALAMAZOO_DRAWING\PROJ\2220555_WELL SITE_COVER.DWG - WSMYH - Apr 29 2025 - 10:54am - Prein&Newhof

BENCHMARK EL. 760.10
 W CROSSSTOWN PARKWAY & BORN COURT
 70± SE & 2' N OF C/L "X", NAIL SET IN
 EAST SIDE OF POWER POLE
 (0.5' A/GROUND)

POINT No.	NORTHING	EASTING	ELEVATION
10175	286359.318	12793983.570	761.24
91500	286381.158	12784136.120	759.62

BORING LOG

SCALE: VERT. 1" = 4'

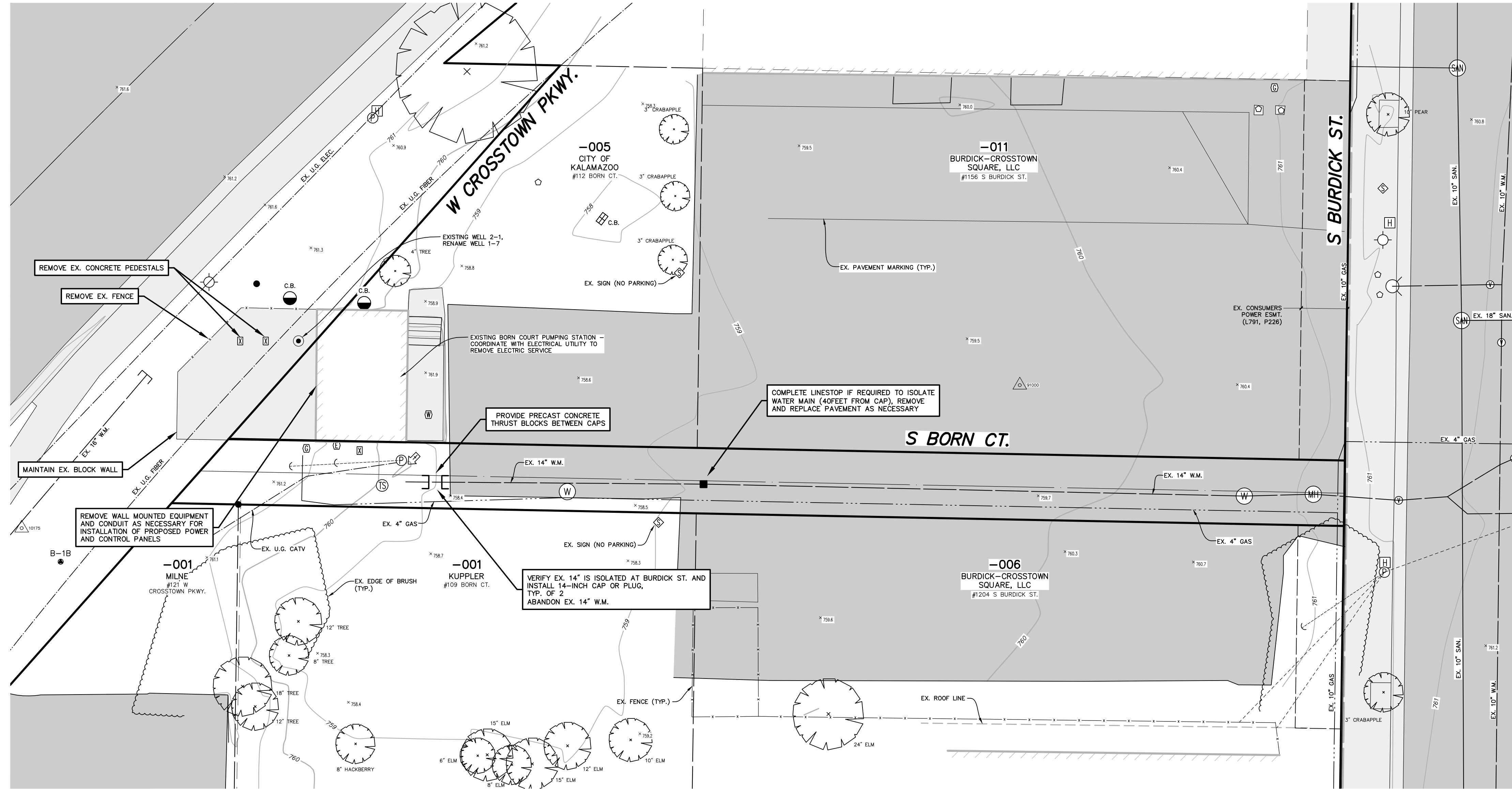
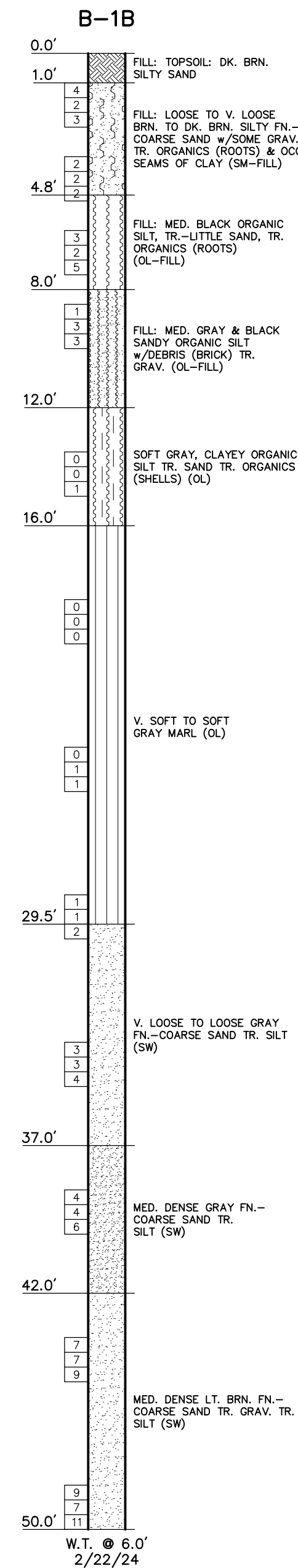

EXISTING SITE PLAN

SCALE: 1" = 10'



SOIL EROSION & SEDIMENTATION CONTROL NOTE

PRIOR TO BEGINNING ANY EARTH DISTURBANCE, CONTRACTOR SHALL PROTECT CATCH BASINS (C.B.) ON SITE WITH SILT SACKS AND INSTALL SILT FENCE TO PREVENT MIGRATION OF SOIL/SEDIMENT AWAY FROM THE WORK AREA.
 CONTRACTOR SHALL BE RESPONSIBLE FOR OBTAINING A SOIL EROSION AND SEDIMENTATION CONTROL PERMIT PER SPECIFICATIONS.

I:\QA\3D PROJECTS\2023\2220555_CITY OF KALAMAZOO\DWRF\4-PROJ\2220555_SITE_EX_MLL_SITE_PLANNING - WSWTH - Mar. 31 2025 - 08:32am - Prein&Newhof

811
 Know what's below.
 Call before you dig.

UTILITY LOCATIONS ARE DERIVED FROM ACTUAL MEASUREMENTS OR AVAILABLE RECORDS. THEY SHOULD NOT BE INTERPRETED TO BE EXACT LOCATIONS NOR SHOULD IT BE ASSUMED THAT THEY ARE THE ONLY UTILITIES IN THIS AREA.

NO.	REVISIONS	BY	DATE	DRAWN STAFF
-	-	-	-	STAFF
-	-	-	-	DATE: FEB. '25
-	-	-	-	CHECKED: P.W.B.
-	-	-	-	DATE: FEB. '25

Prein & Newhof
 Engineers • Surveyors • Environmental • Laboratory

CITY OF KALAMAZOO DWRF
 KALAMAZOO COUNTY, MICHIGAN
 WATER SUPPLY SYSTEM IMPROVEMENTS
 EXISTING SITE PLAN

PROJECT NO. 2220555
 SHEET NO. 2 OF 8

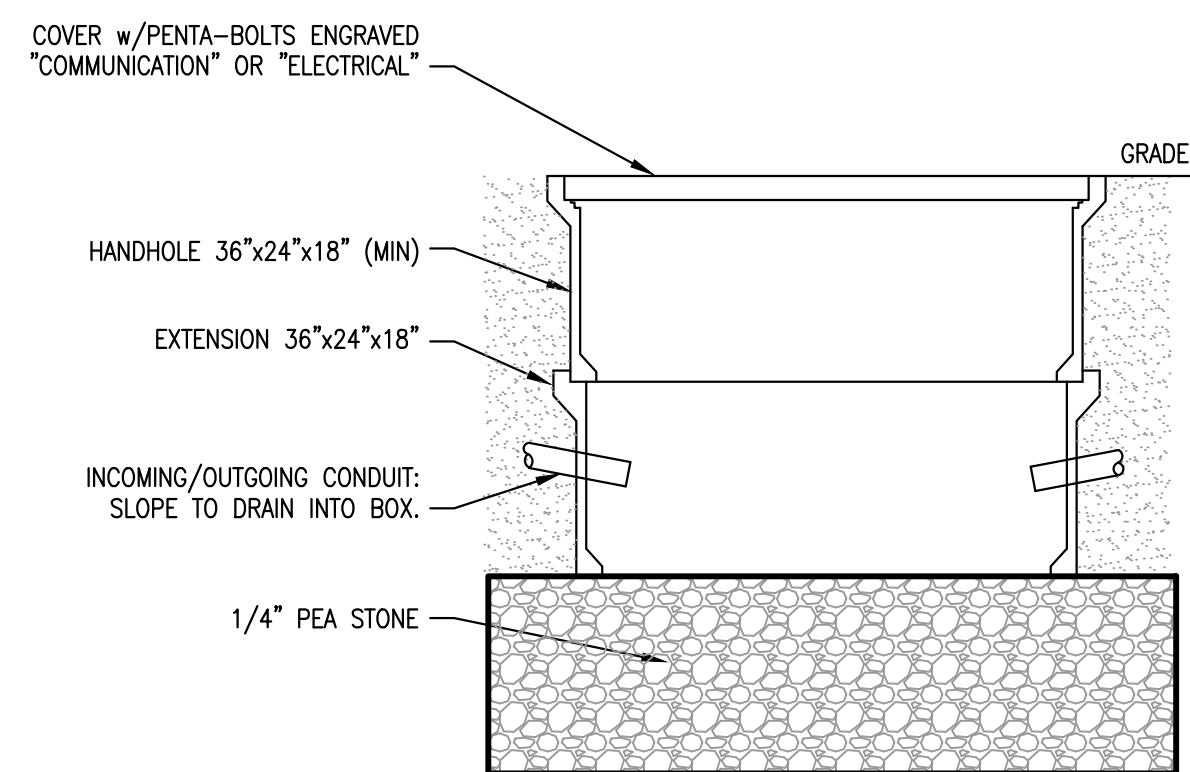

NOTE
 LOOP CABLE MINIMUM TWICE AROUND INTERIOR OF HANDHOLE. PROVIDE STAINLESS STEEL I HOOKS AS REQUIRED TO SUPPORT CABLE. CABLES SHALL HAVE NO SPLICES FROM SOURCE TO LOAD UNLESS NOTED OTHERWISE.

IN-GROUND HANDHOLE DETAIL

SCALE: NONE

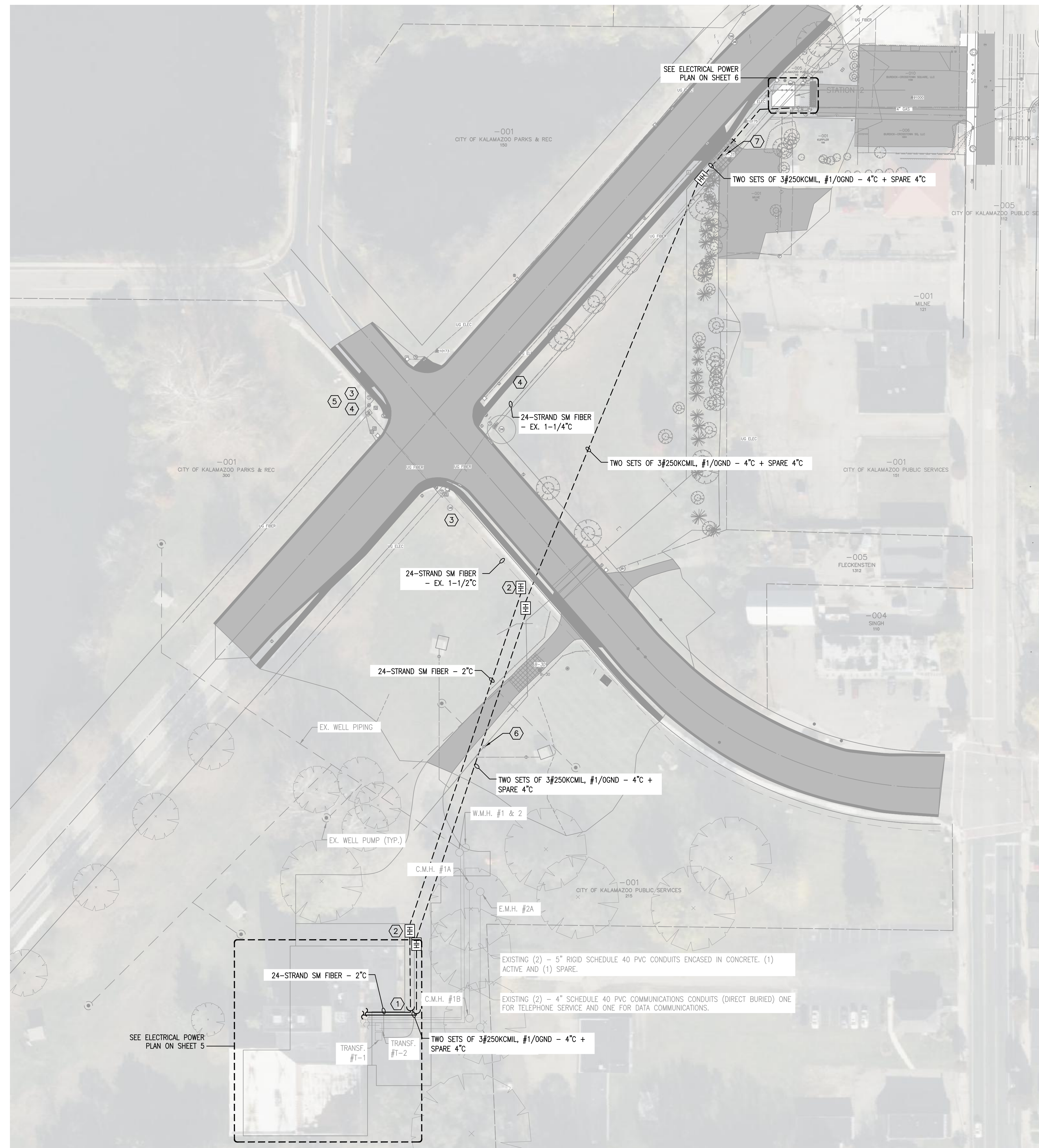

GENERAL NOTES:

1. TRANSITION FROM RMC TO PVC BELOW GRADE.
2. CONDUIT ROUTING SHOWN IS APPROXIMATE. THE CONDUIT ARRANGEMENT MAY VARY BASED ON ROUTING REQUIREMENTS. VERIFY EXACT CONDUIT ROUTING WITH CITY OF KALAMAZOO.
3. PROVIDE HANDHOLES AS REQUIRED TO MAINTAIN NEC 360° TOTAL BENDS BETWEEN PULL POINTS.
4. PROVIDE LARGE RADIUS SWEEP BENDS FOR FIBER OPTIC CABLES.
5. PROVIDE TRACER WIRE FOR ALL CONDUITS.
6. POTHOLE EXISTING UTILITIES FOR ALL PLANNED UTILITY CROSSINGS.

PLAN NOTES: (Symbol) - (SYMBOL DENOTES PLAN NOTE)

1. ROUTE CONDUITS OUT OF WALL ABOVE EXISTING CAMERA JUNCTION BOX. ROUTE CONDUIT ALONG SOUTHERN WALL ABOVE LOUVER, AROUND CORNER, AND DROP DOWN ON EAST WALL. PROVIDE RMC ELBOW BEFORE TRANSITION TO SCHEDULE 80 HDPE BELOW GRADE.
2. INTERCEPT EXISTING FIBER CONDUIT AND INSTALL PROPOSED SLOTTED FIBER HANDHOLE. PROVIDE 24 STRAIGHT-THRU SPLICES.
3. PULL FIBER CONDUIT FROM CENTRAL COMMUNICATIONS CABINET TO TRAFFIC CONTROL CABINET. COORDINATE PULLING AND TERMINATION REQUIREMENTS WITH CITY OF KALAMAZOO.
4. PULL FIBER CONDUIT FROM TRAFFIC CONTROL CABINET TO WELL BUILDING. COORDINATE PULLING AND TERMINATION REQUIREMENTS WITH CITY OF KALAMAZOO.
5. PROVIDE 48 FIBER PIGTAILS WITHIN EXISTING TRAFFIC CONTROL CABINET.
6. EXCAVATE AND EXPOSE VALVE BOX TEMPORARILY AND PROTECT DURING CONDUIT INSTALLATION. INSTALL CONDUIT A MINIMUM OF 3'-0" FROM VALVE BOX. AFTER CONDUIT IS INSTALLED, BACKFILL AND RESTORE THE SITE TO PREEXISTING CONDITION.
7. COORDINATE THE BORING OF CONDUITS TO WELLHOUSE WITH OWNER TO AVOID DAMAGE TO EXISTING STORM DRAIN PIPING IN THE ENTRY DRIVE TO PARKING LOT.

ELECTRICAL SITE PLAN - PROPOSED

SCALE : 1" = 20'



NO.	REVISIONS	BY	DATE	DRAWN
				JZJ
				MAY '25
				CHECKED
				MAT
				DATE
				MAY '25

CENTURY A&E
 Facilities Design

277 Crahen Avenue NE - Grand Rapids, MI 49525
 Telephone: (616) 456-5227 / Fax: (616) 456-5228 / Web: www.centuryae.com

Prein & Newhof
 Engineers • Surveyors • Environmental • Laboratory

CITY OF KALAMAZOO DWRP
 KALAMAZOO COUNTY, MICHIGAN
 WATER SUPPLY SYSTEM IMPROVEMENTS
 ELECTRICAL SITE PLAN

PROJECT NO.
 2220555

SHEET NO.

4 OF 8

CONDUIT AND CABLE SCHEDULE

MARK	DESCRIPTION
ⓐ	
A	2 SETS OF 3#250KCMIL, #1/GND - 4°C
B	6-STR SINGLE-MODE FIBER - 3/4°C
C	24-STR SINGLE-MODE FIBER - 2°C
NOTE:	

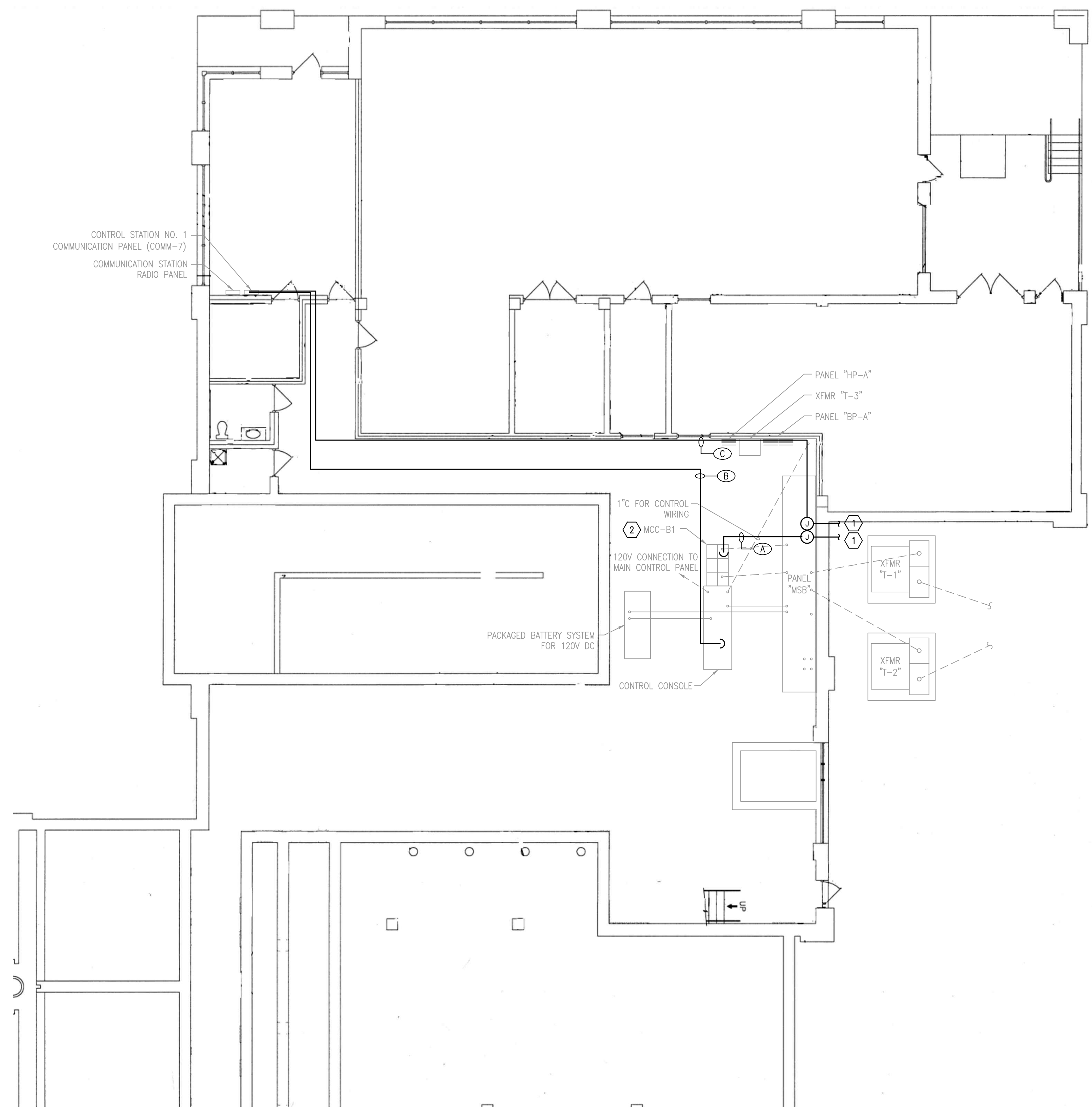

ELECTRICAL POWER PLAN
SCALE : 1/4" = 1'-0"



- PLAN NOTES:** ⓐ (SYMBOL DENOTES PLAN NOTE)
- SEE CONTINUATION ON SHEET 4.
 - REFER TO SINGLE-LINE DIAGRAM ON SHEET 8.
 - PROVIDE COMPONENTS AS REQUIRED FOR TERMINATION. COORDINATE REQUIREMENTS WITH CITY OF KALAMAZOO.

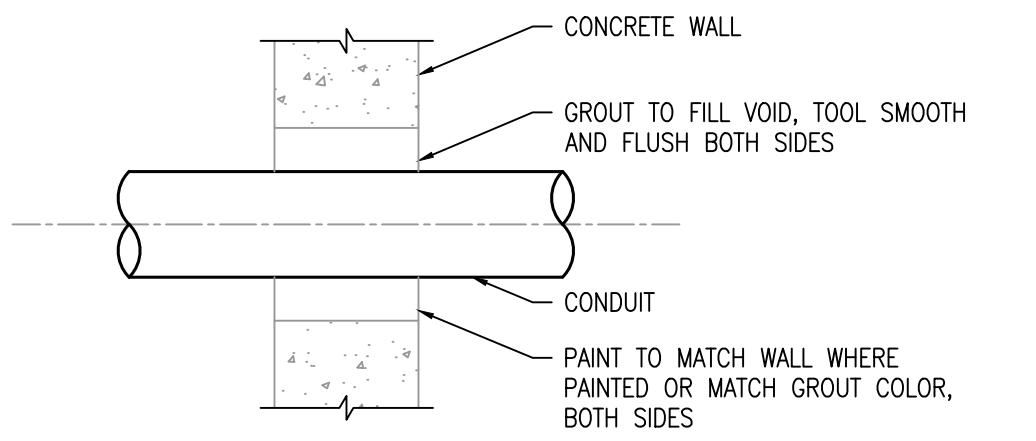

INTERIOR WALL PENETRATION DETAIL
SCALE : NONE

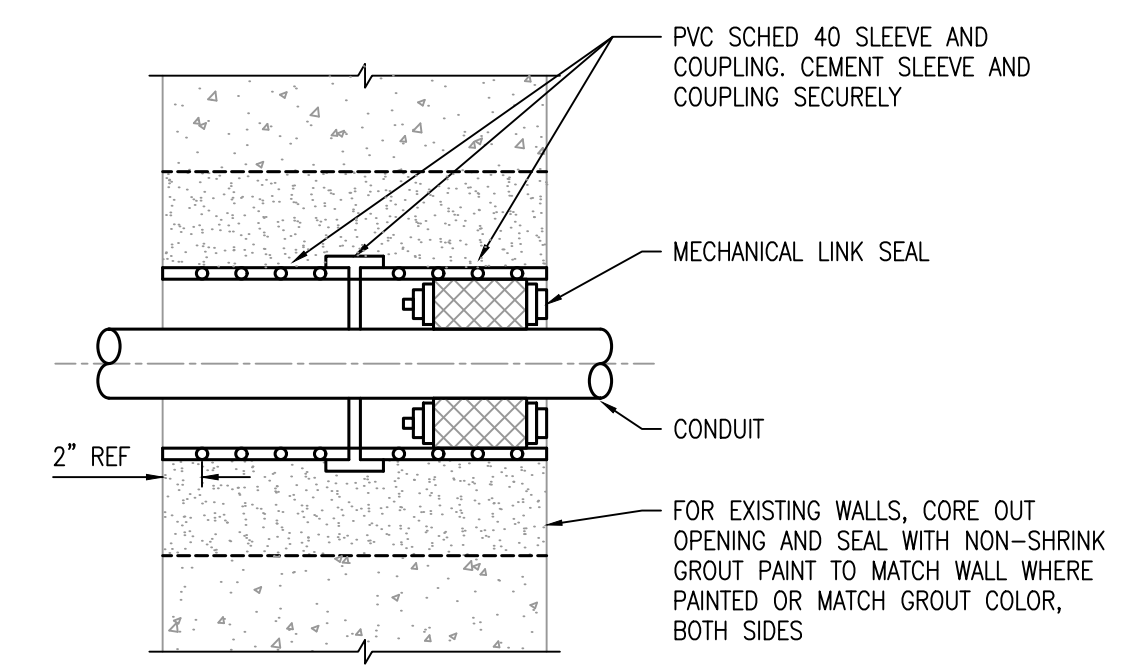

EXTERIOR WALL CONDUIT SLEEVE DETAIL
SCALE : NONE

C:\USERS\JONES\APPDATA\LOCAL\TEMP\KORBERSL_7128\PM074 ELEC POWER PLAN.DWG - JONES - May, 13, 2025 - 05:17pm - PreinMech.dwg

NO.	REVISIONS	BY	DATE	DRAWN
				JZJ
				DATE MAY '25
				CHECKED MAT
				DATE MAY '25

CENTURY A&E
Facilities Design
277 Crahen Avenue NE - Grand Rapids, MI 49525
Telephone: (616) 456-5227 / Fax: (616) 456-5228 / Web: www.centuryae.com

Prein&Newhof
Engineers • Surveyors • Environmental • Laboratory

CITY OF KALAMAZOO DWRP
KALAMAZOO COUNTY, MICHIGAN
WATER SUPPLY SYSTEM IMPROVEMENTS
ELECTRICAL POWER PLAN

PROJECT NO.
2220555
SHEET NO.
5 OF 8

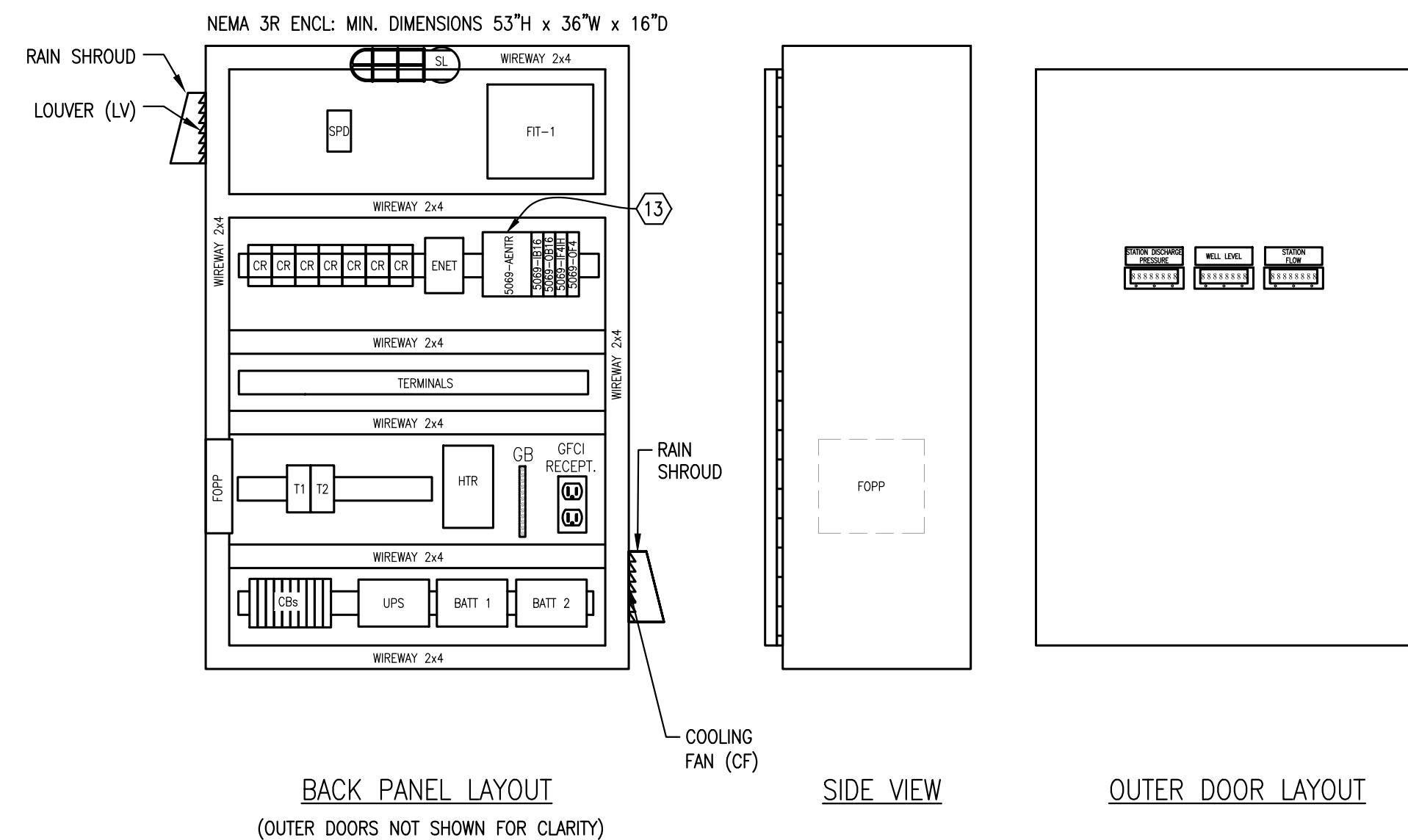

WELL CONTROL PANEL 1-7 (CP) DETAIL (15)

GENERAL NOTES:

- PROVIDE THESE CONDUIT TYPES IN THE FOLLOWING LOCATIONS:
 - RMC - OUTDOOR ABOVE GRADE.
 - SCH. 40 PVC - BELOW GRADE AND IN-SLAB.
 - SCH. 80 PVC - BELOW GRADE UNDER AREAS EXPOSED TO VEHICULAR TRAFFIC.
- PROVIDE RMC CONDUIT AND ELBOWS FOR ALL STUB UPS TO EQUIPMENT EXTENDING UP THRU CONCRETE SLABS FOR TRANSITION FROM CONCEALED/UNDERGROUND TO EXPOSED CONDUIT INSTALLATION. PROVIDE SCH. 40 PVC SLEEVES FOR ALL CONDUITS EXTENDING UP THROUGH CONCRETE SLABS.
- USE RMC CONDUIT ELBOWS IN ALL UNDERGROUND CONDUIT INSTALLATIONS.
- ALL INSTRUMENTATION DEVICES FURNISHED BY THE INSTRUMENTATION CONTRACTOR ARE INSTALLED BY THE ELECTRICAL CONTRACTOR. ELECTRICAL CONTRACTOR SHALL PROVIDE FIELD WIRING, CONDUIT & TERMINATIONS FOR THOSE DEVICES AS REQUIRED.
- FOR GENERAL USE 20A RECEPTACLES, PROVIDE MINIMUM 2#12, #12GND - 3/4".

DEMOLITION NOTES: (SYMBOL DENOTES PLAN NOTE)

- DEMOLISH EXISTING WELL-BUILDING ELECTRICAL SERVICE. COORDINATE REQUIREMENTS WITH CONSUMERS ENERGY.
- CONTRACTOR SHALL COORDINATE WITH OWNER TO CONNECT PORTABLE GENERATOR TO VERIFY PHASE & ROTATION.
- COORDINATE INSTALLATION AND WIRING WITH PIPE INSULATION SYSTEM.
- LOOP ADDITIONAL HEAT TRACE CABLE AT PIPE COUPLINGS, VALVES, AND JOINT LOCATIONS.
- ROUTE RTD SENSOR CONDUCTORS IN CONDUIT FROM SENSOR HEAD TO CONTROLLER.
- LOCATE TEMPERATURE SENSORS IN PIPING OUTSIDE OF THE TEMPERATURE INFLUENCE OF ADJACENT BUILDING OR TANKAGE. LOCATE SENSORS TO BE IN LOCATIONS THAT ARE REPRESENTATIVE OF THE TEMPERATURE OF THE MAJORITY OF THE PROCESS FLUID BEING MEASURED. COORDINATE WITH SYSTEM SUPPLIER.
- UTILIZE PIPE STAND OFF TO EXTEND CONNECTION POINT ABOVE INSTALLATION.
- ALL PIPING THAT TRANSITIONS TO BELOW GRADE SHALL BE TRACED TO 36" BELOW GRADE. PROVIDE INSULATION UP TO 1'-0" BELOW GRADE. NO SPLICES OR END SEAL KITS SHALL BE LOCATED BELOW GRADE.
- FOR PIPES 6" OR LARGER, ROUTE HEAT TRACE DOWN PROCESS PIPING AND BACK SUCH THAT END SEAL KIT IS LOCATED ADJACENT TO POWER CONNECTION KIT. ENSURE END SEAL KIT IS READILY ACCESSIBLE WITHOUT ADDITIONAL EQUIPMENT.
- PROVIDE SMALL LIU SPLICE BOX FOR FIBER TERMINATIONS. COORDINATE EXACT LOCATION WITH CITY OF KALAMAZOO.
- PROVIDE 30'+ ADDITIONAL CONDUCTOR SERVICE LOOP AND ENCLOSURE TO HOUSE EXCESS CABLE ADJACENT TO DISCONNECT.
- PROVIDE 24 STRAIGHT-THRU SPLICES WITHIN EXISTING HANDHOLE.
- PROVIDE 50' OF ADDITIONAL FIBER LOOPED WITHIN HANDHOLE FOR FUTURE TERMINATION LOCATION MODIFICATIONS.
- PROVIDE W/ FOUR (4) 5069-RTB18-SCREW AND ONE (1) 5069-RTB5-SCREW
- PROVIDE DIE-CAST PADLOCKABLE WHILE-IN-USE WEATHERPROOF RECEPTACLE COVER.
- CONTROL PANEL SHALL HAVE INTEGRAL PADLOCK HASP.

PLAN NOTES: (SYMBOL DENOTES PLAN NOTE)

CONDUIT AND CABLE SCHEDULE

MARK	DESCRIPTION
(15)	
A	2 SETS OF 3#250KCMIL, 2#1/0GND - 4" C
B	6-STR MULTI-MODE FIBER - 3" C (SCH. 40 PVC)
C	INSTRUMENT MANUFACTURER'S CABLE - 1-1/4" C
D	PUMP MFG. POWER CABLE, INCLUDES SENSOR CONDUCTORS 2-1/2" C
E	2#12, #12GND - 3/4" C
F	8#14, #14GND - 3/4" C

NOTE:

PIPE HEAT TRACE SCHEDULE													
DESCRIPTION	FUNCTION	PIPE			INSULATION		HEAT CABLE			TEMPERATURE SENSOR		POWER	
		SIZE	LENGTH (FT.)	MATERIAL	THICKNESS	TYPE	LENGTH (FT.)	WATTS (W/FT)	TYPE	TYPE	SETTING	VOLTAGE	CIRCUIT
WATER PIPING	FREEZE PROTECTION	8"	21	150# STAINLESS	2"	POLYISOCYANURATE W/ SS JACKET	100	8	CHROMALOX MODEL# SRLB-1CT, OR EQUAL	LINE SENSING	50°F	120V	CB11 (20A GFPE CB)
HEAT TRACE	SELF-REGULATING HEATING CABLE THAT VARIES ITS POWER OUTPUT RELATIVE TO TEMPERATURE. NICKEL-PLATED COPPER BUS WIRES WITH TINNED COPPER BRAID AND FLUOROPOLYMER CORROSION RESISTANT OVERJACKET. CHROMALOX SRLB-1CT OR EQUAL. QTY. 50 FT MINIMUM.												
LIGHTED END SEAL KIT	TERMINATION DEVICE WITH RED INDICATING LIGHT AND PIPE STANDOFF WITH CABLE GROMMET. CHROMALOX UESL OR EQUAL. QTY. 1 MINIMUM.												
METAL PIPE STRAP	CHROMALOX PS-10 OR EQUAL. QTY. PS-10, 2 MINIMUM.												
CAUTION LABEL PACK	WEATHER RESISTANT WARNING LABEL. CHROMALOX CL-1, OR EQUAL, 5 PER PACK. QTY. 1 MINIMUM.												
FIBERGLASS TAPE	FOR USE WITH METALLIC PIPE, INSTALL BELOW AND ABOVE HEAT TRACE: GLASS CLOTH TAPE WITH PRESSURE-SENSITIVE THERMOSETTING ADHESIVE, 66 FT. ROLL. CHROMALOX FT-3, OR EQUAL. QTY. 3 ROLLS MINIMUM.												
PHENOLIC LABEL	DEVICE NAMETAG LABEL. LABEL EACH CONTROLLER, RTD SENSOR HEAD, AND END LIGHT WITH CONTROLLER AND CIRCUIT NUMBER. QTY. 3 MINIMUM.												
NOTE: QUANTITY OF SOME COMPONENTS DEPENDS PARTIALLY ON INSTALLATION CONFIGURATION. MORE QUANTITY MAY BE REQUIRED, LESS SHOULD NOT BE UTILIZED.													

- HEAT TRACE SPECIFICATION:**
- SELF REGULATING HEAT TRACE:**
- SHALL BE CHROMALOX SRLB-1CT OR EQUAL, 8 WATT/FOOT, 120V WITH FLUOROPOLYMER JACKET OVER BRAID. MUST BE RATED FOR MAINTAINED TEMPERATURES OF 150F WITH POWER OFF EXPOSURE OF 185F. CABLE, AND ACCESSORIES. FIBERGLASS TAPE CHROMALOX MODEL FT-1 OR EQUAL MUST BE APPLIED TO THE PIPE ABOVE THE HEAT TRACE EVERY FOOT. SERVICE LOOPS SHALL BE INSTALLED AT ALL PIPE SUPPORTS, POWER CONNECTIONS AND END SEALS PER MANUFACTURER INSTRUCTIONS. ADDITIONAL CABLE MUST BE APPLIED TO ALL VALVES AND FLANGES PER MANUFACTURER INSTRUCTIONS.
- HEAT TRACE ACCESSORIES:**
- SHALL BE CHROMALOX U SERIES OR EQUAL. END SEALS SHALL BE CHROMALOX MODEL UESL OR EQUAL, LIGHTED END SEAL KITS. CAUTION LABELS "WARNING ELECTRIC HEAT TRACE" MUST BE APPLIED EVERY 10 FT OF PIPE.
- HEAT TRACE CONTROLS:**
- SHALL BE CHROMALOX MODEL DTS/HAZ OR EQUAL. SHALL BE RATED FOR 30 AMPS AT 120V TO 277V. SHALL PROVIDE BUILT IN SOFT START, LINE SENSING RTD, LED DISPLAY AND ALARM CONTACT.

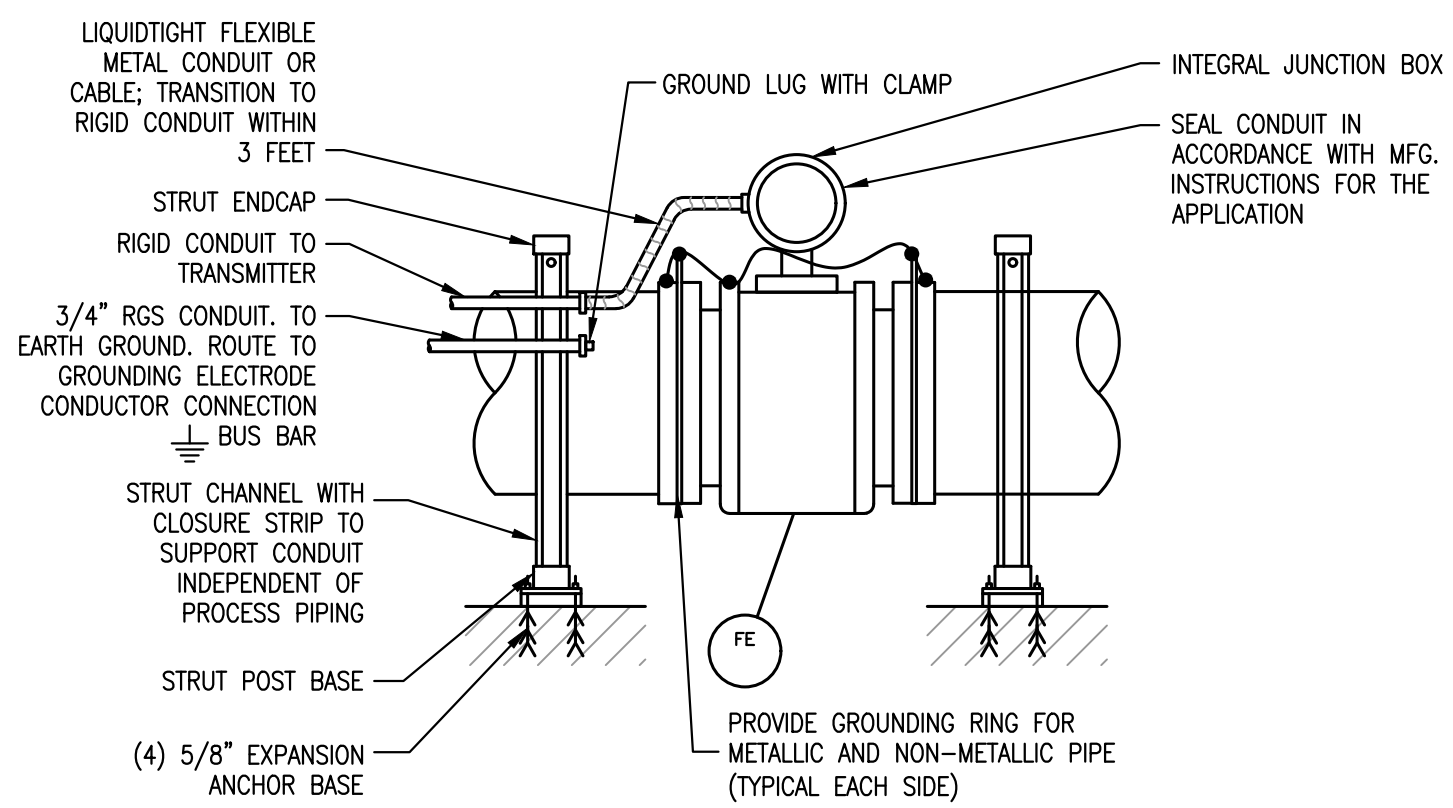

MAGNETIC FLOWMETER INSTALLATION DETAIL (REMOTE TRANSMITTER)

SCALE: NONE
NOTE: PROVIDE DRIP LEG FOR CONDUITS TO/FROM ABOVE.

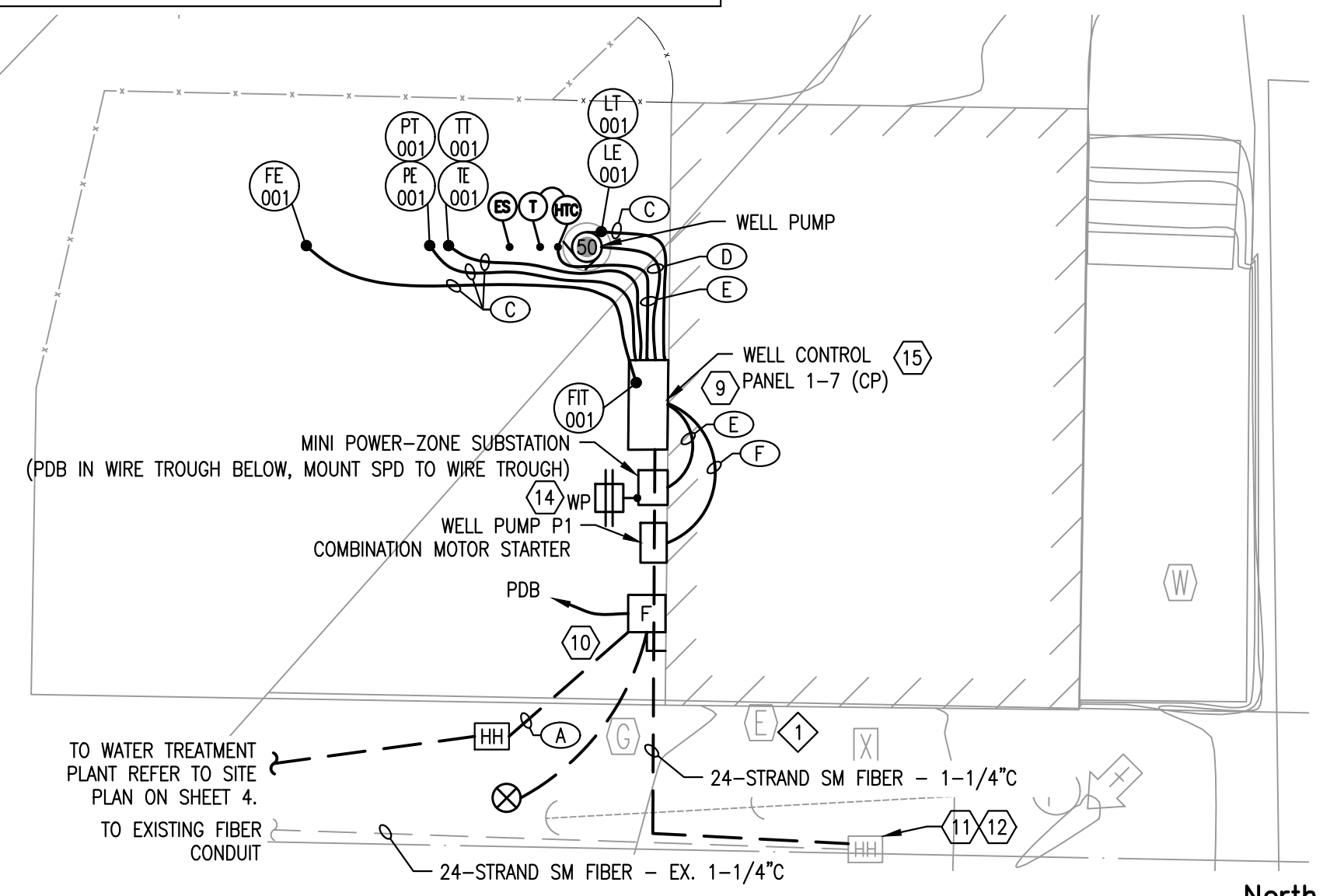

ENLARGED WELLHOUSE ELECTRICAL SITE PLAN - PROPOSED

SCALE: 1" = 5'

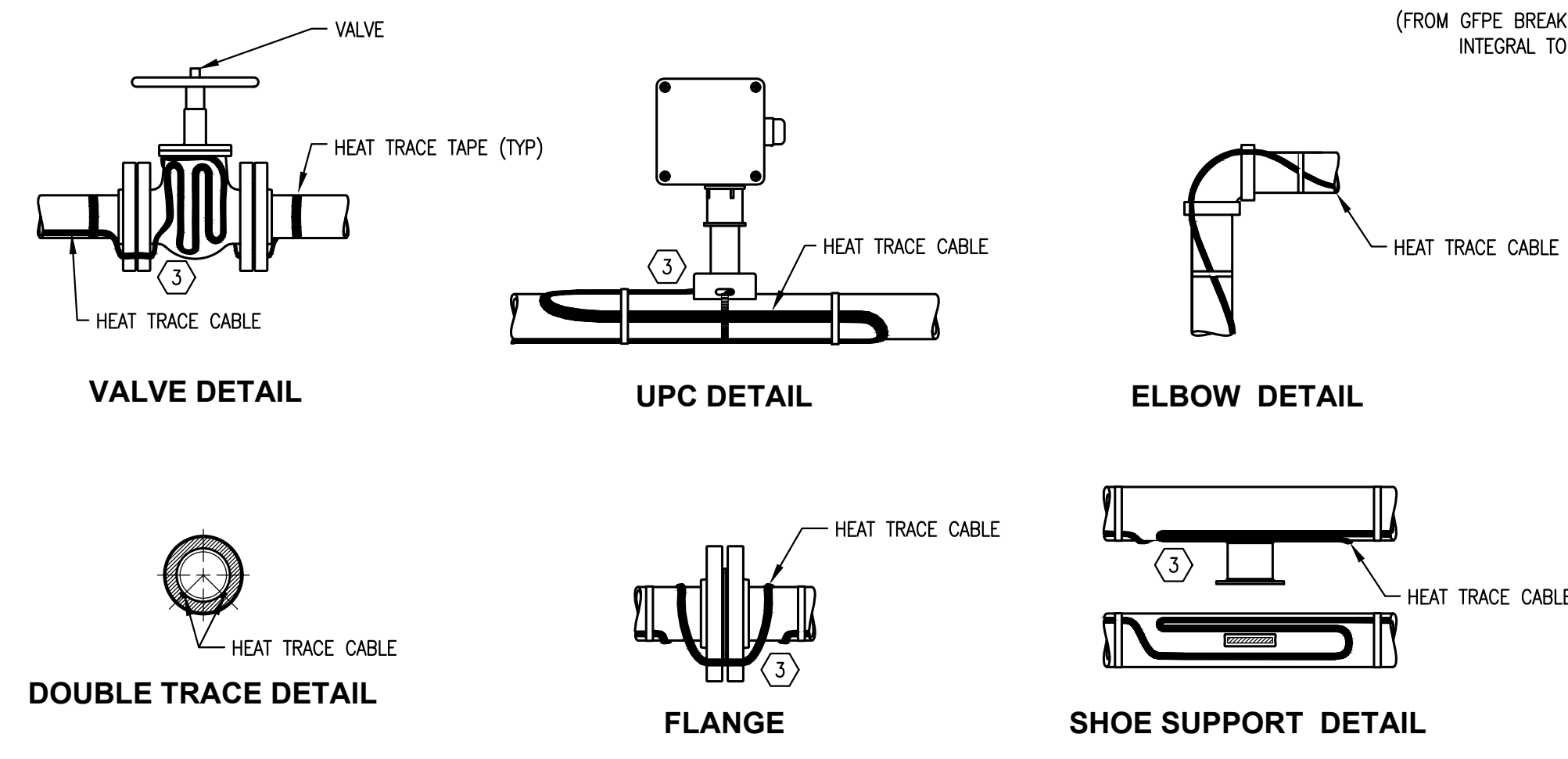

HEAT TRACE INSTALL DETAILS (2/8)

SCALE: NONE

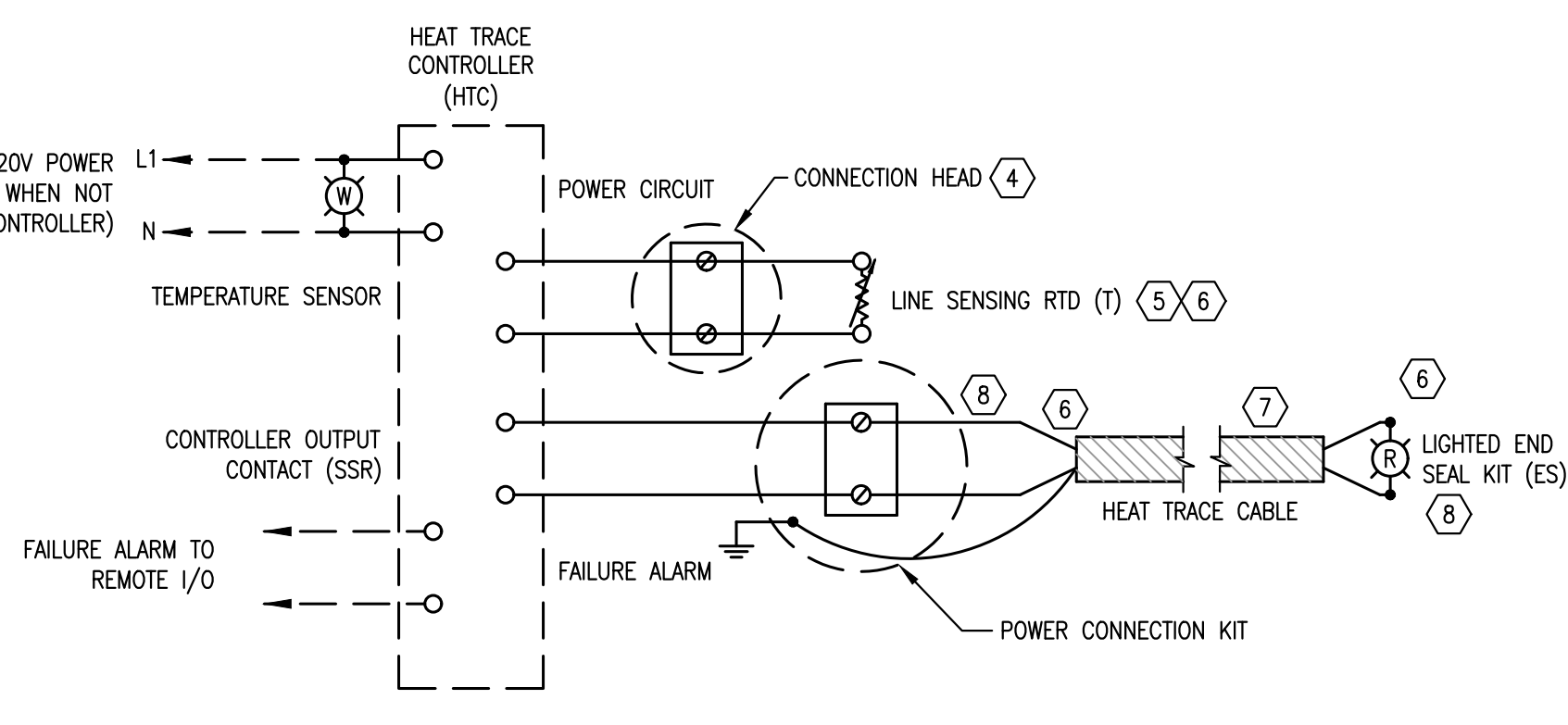

HEAT TRACE WIRING DIAGRAM (2/8)

PROVIDE ALL ASSOCIATED POWER CONNECTIONS, END TERMINATIONS AND MATERIALS FOR A COMPLETE INSTALLATION OF THE HEAT TRACE SYSTEM. SEE HEAT TRACE SCHEDULE ON THIS SHEET. COORDINATE WITH OTHER TRADES.

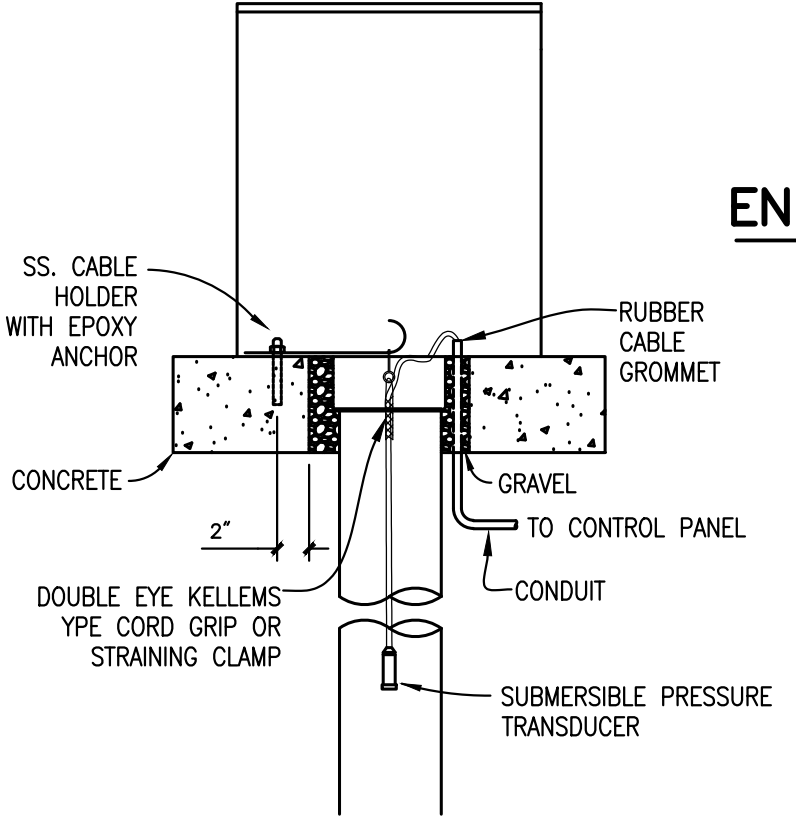

LEVEL TRANSDUCER (LT) SUPPORT DETAIL

SCALE: NONE

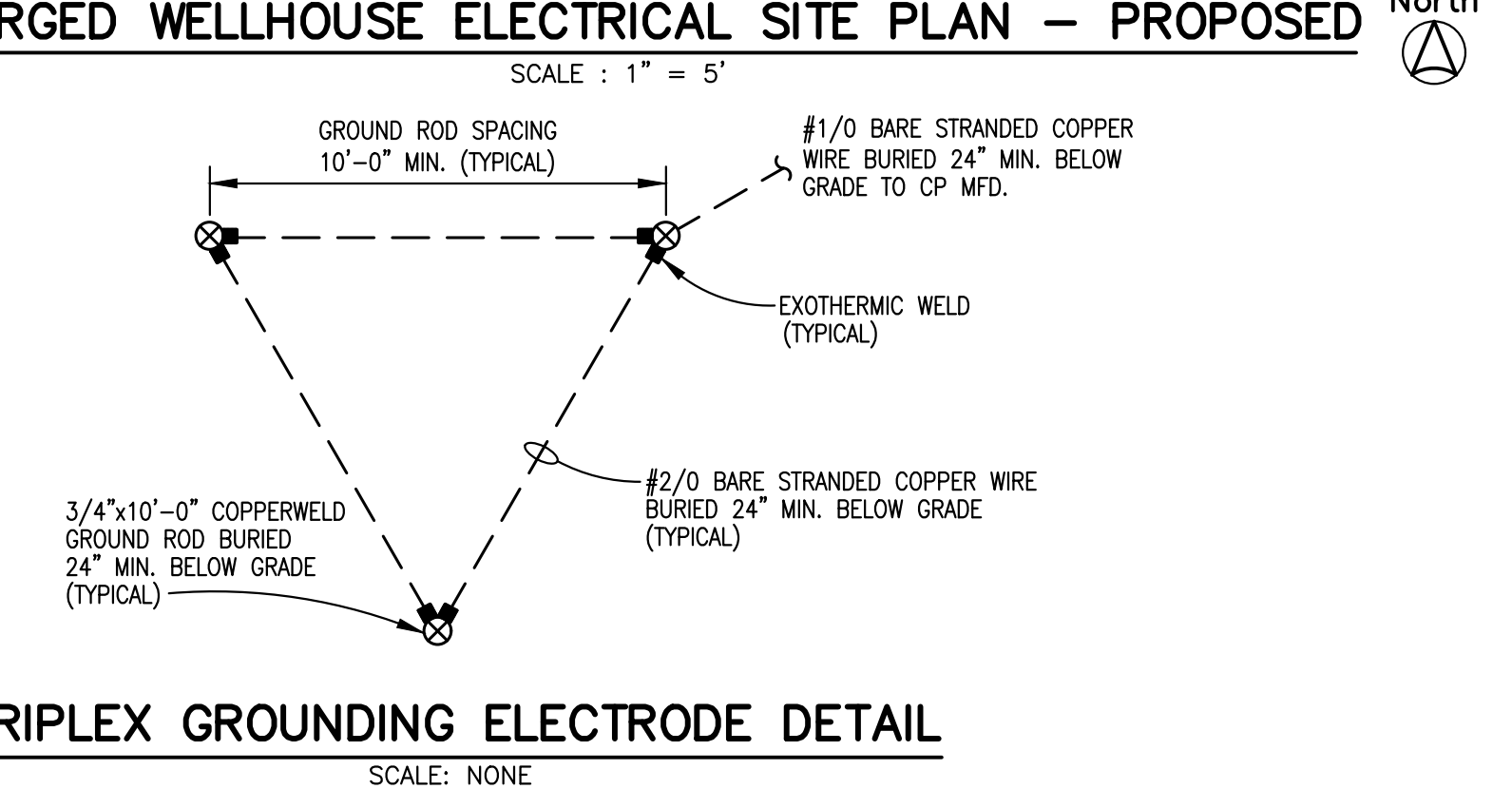

TRIPLEX GROUNDING ELECTRODE DETAIL

SCALE: NONE

NO.	REVISIONS	BY	DATE	DRAWN
				JZJ
				MAY '25
				CHECKED
				MAT
				DATE
				MAY '25

CENTURY A&E
Facilities Design
277 Crahan Avenue NE - Grand Rapids, MI 49525
Telephone: (616) 456-5227 / Fax: (616) 456-5228 / Web: www.centuryae.com

Prein & Newhof
Engineers • Surveyors • Environmental • Laboratory

CITY OF KALAMAZOO DWRP
KALAMAZOO COUNTY, MICHIGAN
WATER SUPPLY SYSTEM IMPROVEMENTS
ELECTRICAL SITE PLAN AND DETAILS

PROJECT NO.
2220555
SHEET NO.
6 OF 8

DEMOLITION NOTES: (Symbol denotes plan note)

1. PREPARE SPACE FOR PROPOSED FEEDER BUCKET. PROVIDE COVER FOR EXISTING CONTROLS.

PLAN NOTES: (Symbol denotes plan note)

1. PROVIDE PROPOSED FEEDER BUCKET WITHIN EXISTING ALLEN BRADLEY BULLETIN 2100 MOTOR CONTROL CENTER.
2. PROVIDE DOUBLE-LUG KIT AND/OR ENCLOSED POWER DISTRIBUTION BLOCK WITHIN BUCKET AS REQUIRED FOR UPSIZED FEEDER CONDUCTORS.

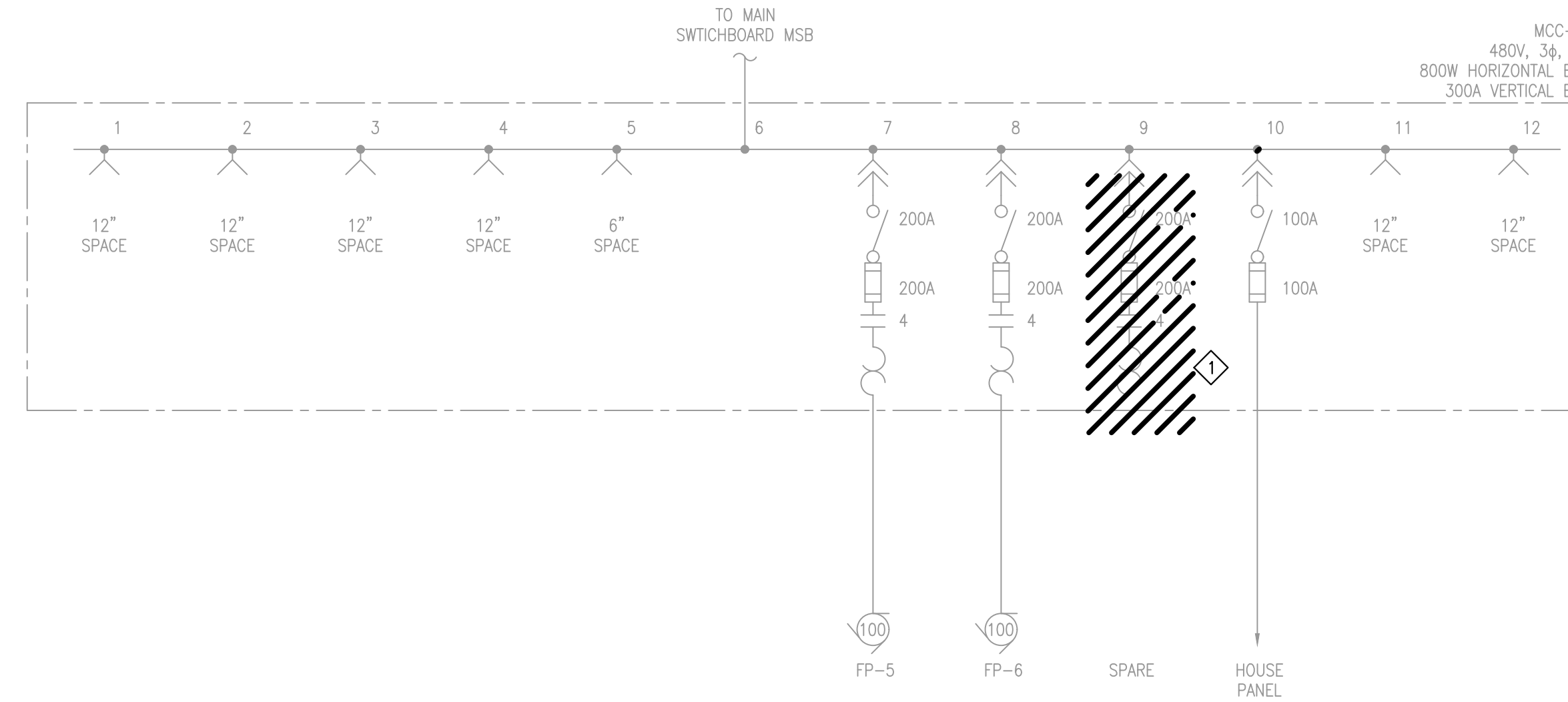

SINGLE-LINE DIAGRAM – EXISTING

SCALE : N.T.S.

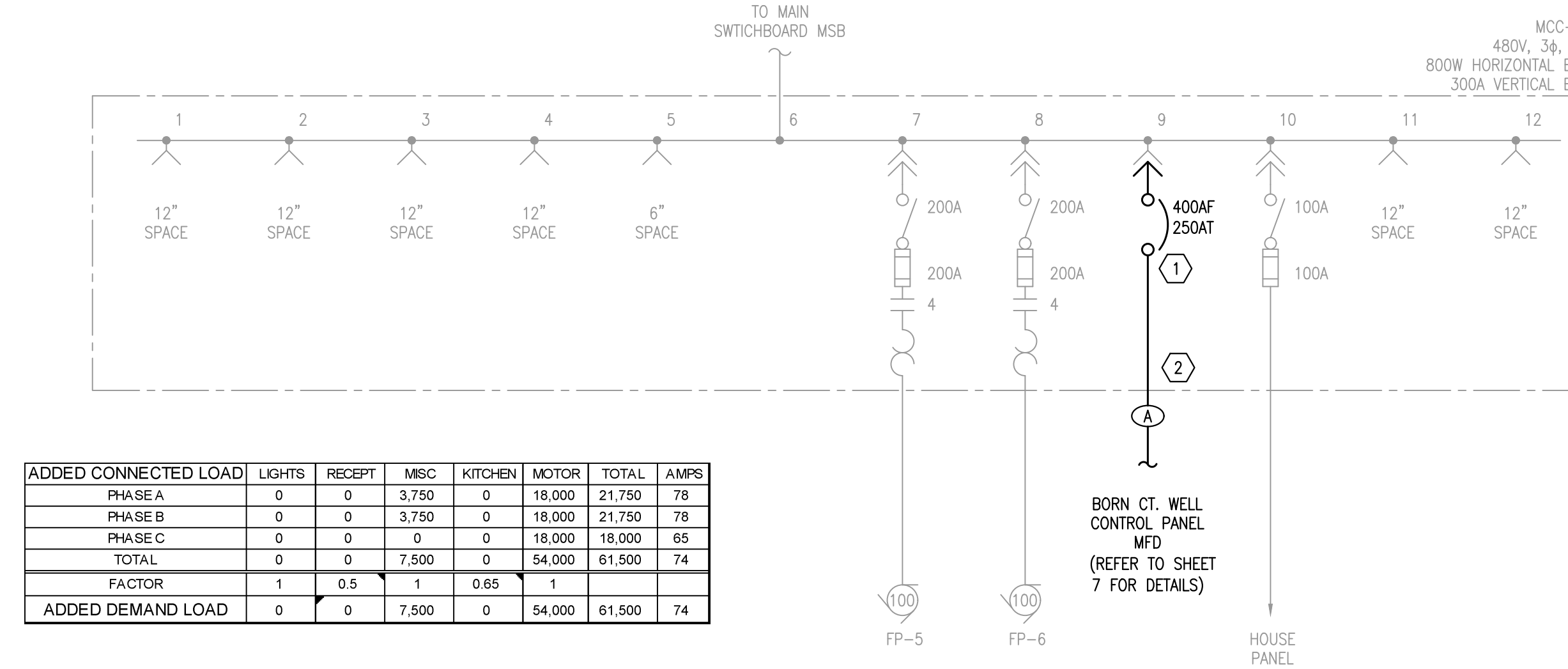

SINGLE-LINE DIAGRAM – PROPOSED

SCALE : N.T.S.

ADDED CONNECTED LOAD	LIGHTS	RECEPT	MISC	KITCHEN	MOTOR	TOTAL	AMPS
PHASE A	0	0	3,750	0	18,000	21,750	78
PHASE B	0	0	3,750	0	18,000	21,750	78
PHASE C	0	0	0	0	18,000	18,000	65
TOTAL	0	0	7,500	0	54,000	61,500	74
FACTOR	1	0.5	1	0.65	1		
ADDED DEMAND LOAD	0	0	7,500	0	54,000	61,500	74

BORN CT. WELL CONTROL PANEL MFD (REFER TO SHEET 7 FOR DETAILS)

CONDUIT AND CABLE SCHEDULE

MARK	DESCRIPTION
(Symbol)	
A	2 SETS OF 3#250KCMIL, #1/0GND – 4°C

NOTE:

F:\PROJECTS\PM0704\CAD\ELECT\PM0704 ELEC ONE-LINE DIAGRAM.DWG - JONES - May, 13, 2025 - 05:11pm - Prein&Newhof

NO.	REVISIONS	BY	DATE	DRAWN
				JZJ
				DATE MAY '25
				CHECKED MAT
				DATE MAY '25

CENTURY A&E
Facilities Design
277 Crahen Avenue NE - Grand Rapids, MI 49525
Telephone: (616) 456-5227 / Fax: (616) 456-5228 / Web: www.centuryae.com

Prein&Newhof
Engineers • Surveyors • Environmental • Laboratory

CITY OF KALAMAZOO DWRP
KALAMAZOO COUNTY, MICHIGAN
WATER SUPPLY SYSTEM IMPROVEMENTS
ELECTRICAL SINGLE-LINE DIAGRAM

PROJECT NO.
2220555
SHEET NO.
8 OF 8