



Department of Management Services
Purchasing Division
241 West South Street
Kalamazoo, MI 49007-4796
Phone: 269.337.8020
www.kalamazoo.org

INVITATION FOR BIDS (IFB)

The City of Kalamazoo, Michigan is soliciting sealed bids for:

PROJECT NAME: Academy Street Sidewalk Improvement

BID REFERENCE #: 91347-008.0

IFB ISSUE DATE: August 19, 2025

BID DUE/OPENING DATE: September 16, 2025 @ 3:30 p.m. Local Time
Electronic Bids Will Not Be Accepted.

MAILING ADDRESS & INSTRUCTIONS

Mail To:

Purchasing Division
241 W. South Street
Kalamazoo, MI 49007

Questions for this IFB should be directed to:

Department Contact: Mohith Reddy
Kondlapudi, Senior Civil Engineer at
kondlapudim@kalamazoo.org or (269-360-2977)

Include on the Envelope the Project Name and Bid Reference Number. All Envelopes Must Be Sealed.

You are invited to submit a bid for this project. Specifications, terms, conditions and instructions for submitting bids are contained herein. This Invitation for Bids with all pages, documents and attachments contained herein, or subsequently added to and made a part hereof, submitted as a fully and properly executed bid shall constitute the contract between the City and the successful bidder when approved and accepted on behalf of the City by an authorized official or agent of the City. Please review the bid document as soon as possible and note the **DEADLINE FOR QUESTIONS** in the Instructions to Bidders.

All bidders shall complete and return the Bid and Award page(s) and submit all information requested herein in order for a bid to be responsive. The bid document shall be returned in its entirety, in a properly identified and sealed envelope to the Purchasing Division at the above address. **BIDS MUST BE RECEIVED BEFORE THE DUE DATE - LATE BIDS WILL NOT BE CONSIDERED.** The City reserves the right to postpone the bid opening for its own convenience.

TABLE OF CONTENTS

Table of Contents

STATEMENT OF NO BID 4

SECTION II BID AND AWARD 7

CERTIFICATION 10

SUB-CONTRACTING INFORMATION 11

SECTION V SPECIAL CONDITIONS 18

 1. INTENT 18

 2. SCOPE OF WORK 18

 3. UNIT PRICING 19

 4. TEMPORARY UTILITIES 19

 5. PROGRESS SCHEDULE 19

 6. LIQUIDATED DAMAGES 20

 7. MAINTAINING TRAFFIC 20

 8. COORDINATING 21

 9. WORK HOURS 21

SECTION VI GENERAL CONDITIONS 22

 1. PROJECT MANAGER’S STATUS 22

 2. CONSTRUCTION SCHEDULE AND COORDINATION 22

 3. PROTECTION OF WORK 22

 4. PROTECTION OF PROPERTY 23

 5. REMOVAL OF RUBBISH 23

 6. BRICK SIDEWALK OR PAVEMENT REMOVAL 23

 7. REMOVAL OF PERMANENT TRAFFIC SIGNS AND POSTS 23

 8. PERMANENT TRAFFIC SIGN STAKING 23

 9. LAWN SPRINKLER SYSTEMS 23

 10. SALVAGING DRAINAGE STRUCTURE COVERS 23

 11. REMOVING AND REPLACING CURB AND GUTTER 23

 12. DRAINAGE INLET COVERS (K COVERS) 23

 13. FLY ASH USE IN CONCRETE ITEMS 24

 14. EXISTING WATER MAINS 24

 15. GRADE INTERSECTIONS 24

 16. UNDERGROUND UTILITIES 24

 17. ADJUSTING MONUMENT BOXES 24

 18. PAVEMENT REMOVAL QUANTITIES 24

Academy Street Sidewalk Improvement

Bid Reference #: 91347-008.0

19.	COLD MILLING	24
20.	SITE SECURITY	24
21.	SITE ACCESS	24
22.	MATERIALS INSPECTION AND RESPONSIBILITY	24
23.	GUARANTEE	25
24.	SAFETY	25
25.	SPECIFICATIONS FOR CONSTRUCTION	25
26.	QUANTITIES	25
27.	PRICE.....	25
28.	BASIS FOR PAYMENT	25
29.	PAY ESTIMATES	26
30.	PAYMENT TO CONTRACTOR	26
31.	INSPECTION OF WORK	26
32.	INSPECTION OF SITE	26
33.	LAYING OUT OF WORK	26
34.	SUPERVISION	26
35.	TARDINESS	26
36.	ADDITIONS	26
37.	INSPECTION AND TESTING	26
38.	QUESTIONS.....	27
APPENDIX A		33
NON-DISCRIMINATION CLAUSE FOR ALL CITY OF KALAMAZOO CONTRACTS		33
APPENDIX C		34
APPENDIX D.....		36

STATEMENT OF NO BID

NOTE: If you DO NOT intend to bid on this commodity or service, please complete and return this form immediately. Your response will assist us in evaluating all responses for this important project and to improve our bid solicitation process.

The Purchasing Division of the City of Kalamazoo wishes to keep its bidders list file up-to-date. If, for any reason you cannot supply the commodity/service noted in this bid solicitation, this form must be completed and returned to remain on the particular bid list for future projects of this type.

If you do not respond to this inquiry within the time set for the bid opening date and time noted, we will assume that you can no longer supply this commodity/service, and your name will be removed from this bid list.

- _____ Specifications too "tight", i.e. geared toward one brand or manufacturer only (explain below).
- _____ Specifications are unclear (explain below).
- _____ We are unable to meet specifications.
- _____ Insufficient time to respond to the Invitation for Bid.
- _____ Our schedule would not permit us to perform.
- _____ We are unable to meet bond requirements.
- _____ We are unable to meet insurance requirements.
- _____ We do not offer this product or service.
- _____ Remove us from your bidders list for this commodity or service.
- _____ Other (specify below).

REMARKS: _____

SIGNED: _____ NAME: _____
(Type or Print)

TITLE: _____ DATE: _____

FIRM NAME: _____
(if any)

ADDRESS: _____
(Street address) (City) (State) (Zip)

PHONE: _____ EMAIL: _____

**SECTION I
INSTRUCTIONS TO BIDDERS**

1. **EXAMINATION OF BID DOCUMENT**-Before submitting a bid, bidders shall carefully examine the specifications and shall fully inform themselves as to all existing conditions and limitations. The bidder shall indicate in the bid the sum to cover the cost of all items included on the bid form.
2. **PREPARATION OF BID**-The bid shall be legibly prepared in ink or typed. If a unit price or extension already entered by the bidder on the Bid and Award form is to be altered, it shall be crossed out and the new unit price or extension entered above or below and initialed by the bidder with ink. The bid shall be legally signed and the complete address of the bidder given thereon.
All bids shall be tightly sealed in an envelope plainly marked SEALED BID and identified by project name, bid opening date and time. Bids opened by mistake, due to improper identification, will be so documented and resealed. The Purchasing Division will maintain and guarantee confidentiality of the contents until the specified opening date and time. Bids submitted electronically will not be accepted.
3. **EXPLANATION TO BIDDERS**-Any binding explanation desired by a bidder regarding the meaning or interpretation of the Invitation for Bids (IFB) and attachments must be requested in writing, **at least 5 business days before the bid opening** so a reply may reach all prospective bidders prior to the submission of bids. Any information given to a prospective bidder concerning the IFB will be furnished to all prospective bidders as an amendment or addendum to the IFB if such information would be prejudicial to uninformed bidders. Receipt of amendments or addenda by a bidder must be acknowledged in the bid by attachment, or by letter received before the time set for opening of bids. Oral explanation or instructions given prior to the opening will not be binding.
4. **CASH DISCOUNTS**-Discount offered for payment of less than thirty (30) days will not be considered in evaluating bids for award. Offered discounts of less than thirty (30) days will be taken if payment is made within the discount period, even though not considered in evaluation of the bid.
5. **WITHDRAWAL OF BIDS**-Bids may be withdrawn in person by a bidder or authorized representative, provided their identity is made known and a receipt is signed for the bid, but only if the withdrawal is made prior to the exact time set for receipt of bid. No bid may be withdrawn for at least ninety (90) days after bid opening.
6. **ALTERNATE BIDS**-bidders are cautioned that any alternate bid, unless specifically requested or any changes, insertions or omissions to the terms and conditions, specifications, or any other requirement of this IFB may be considered non-responsive, and at the option of the City, result in rejection of the alternate bid.
7. **LATE BIDS**-Any bid received at the office designated herein after the exact time specified for receipt will not be considered. (Note: The City reserves the right to consider bids that have been determined by the City to be received late due to mishandling by the City after receipt of the bid and no award has been made.)
8. **UNIT PRICES**-If there is a discrepancy between unit prices and their extension, unit prices shall prevail.
9. **BID SUBMITTAL**- Bidders can submit sealed bids in one of the following ways:
 - 9.1. **Mail your bid**, to be received before the bid due date and time indicated in the bid document, to the City of Kalamazoo at the following address:

City of Kalamazoo
Purchasing Division
241 West South Street
Kalamazoo, MI 49007

- 9.2. **Deliver your bid to City Hall In-Person** before the bid due date and time indicated in the bid document.
- 9.3. **Deliver your bid to the Treasurer’s Office Payment Drop Box** located in the northwest corner of City Hall (see photos below) before the bid due date and time indicated in the bid document.



1. Open drop box located at City Hall.

2. Insert SEALED BID here.



- 10. **BID TABULATIONS-** The Purchasing Division makes an effort to post bid tabulations to the City of Kalamazoo website within 24 hours after the bid opening date and time at: <https://www.kalamazoo.org/bidopportunities>. However, in certain cases the posting of the bid tabulation may extend beyond the 24-hour window.

SECTION II
BID AND AWARD

The undersigned having become thoroughly familiar with all of the bid/contract documents incorporated herein, the project site and the location conditions affecting the work, hereby proposes to perform everything required to be performed in strict conformity with the requirements of these documents, and to provide and furnish all the equipment, labor and materials necessary to complete, in a professional manner, the furnishing and installing of all of the following, meeting or exceeding the specifications as set forth herein for the prices as stated below.

ACADEMY STREET SIDEWALK IMPROVEMENT

No	Item Code	Description	Unit	Qty	Unit Price	Extended Price
1	1500001	Mobilization, Max	LS	1		
2	2040055	Sidewalk, Rem	SYD	875		
3	2047001	Curb & Gutter, Rem, Special	FT	110		
4	2080020	Erosion control, inlet protection, Fabric drop	EA	5		
5	8020023	Curb and Gutter, Conc, Det C4	FT	250		
6	3080005	Geotextile separator	SYD	30		
7	8030044	Sidewalk, Conc, 4 inch	SQFT	7,400		
8	8030046	Sidewalk, Conc, 6 inch	SQFT	150		
9	8030036	Sidewalk Ramp, Conc, 6 inch	SQFT	200		
10	8037001	Detectable Warning Surface, Modified	FT	40		
11	8127051	Maintenance of Traffic	LS	1		
TOTAL						

CITY OF KALAMAZOO – INVITATION FOR BIDS
Academy Street Sidewalk Improvement

Bidder shall provide all of the information as requested herein with their bid. Failure to do so and/or failure to provide post-bid requested information may be cause for rejecting the bid as non-responsive.

After receipt of Notice to Proceed, work shall start within 90 days, unless otherwise agreed to by the Project Manager, and **shall be completed within 30 days of beginning, no later than November 1, 2025.**

Bidder/Contractor has examined and carefully studied the bidding documents and attachments, and acknowledges receipt of the following addenda:

Addendum No: _____

Date: _____

By my signature below, I certify that the firm bidding on this contract, when making hiring decisions, does not use a past criminal conviction as a bar to or preclude a person with a criminal conviction from being considered for employment with the bidding firm unless otherwise precluded by federal or state law. I further certify that I have read and agree to be bound by the provisions of the City's Non-Discrimination Clause found in Appendix A as updated by City Ordinance 1856.

Signed: _____ Name: _____

Title: _____

CITY OF KALAMAZOO EX-OFFENDER POLICY CHECKLIST

As part of the City’s commitment to reducing unacceptable poverty, encouraging rehabilitation, reducing recidivism, and strengthening families in Kalamazoo, the City has updated its Purchasing Policy to ensure that firms with whom the City does business share in this commitment by utilizing hiring practices that do not unfairly deny people with arrest and conviction records gainful employment. *(Important: This requirement also extends to any subcontractors the bidder intends to use to fulfill the contract for goods or services being sought from the City.)*

Part I: Proof that the bidder does not inquire about an individual’s past arrest or criminal history on the bidder’s employment application form

- Attach a copy of the current application for employment being used by the bidder

Part II: Certification that the bidder does not use an individual’s past arrest or criminal history to unlawfully discriminate against them by checking *one or more* of the following:

- That pursuant to federal or state law bidder is precluded from hiring persons with certain criminal records from holding particular positions or engaging in certain occupations by providing a cite to the applicable statute or regulation; if checking this box, provide a citation to the applicable statute or rule upon which the bidder is relying: _____
- That bidder conducts criminal history background checks only as necessary, and only after making a conditional offer of employment; that any withdrawal of an offer of employment to an individual because of a past criminal history is job-related and consistent with business necessity after the individual has been provided an individualized assessment opportunity to review and challenge or supplement the history of past criminal conduct being relied upon by the bidder;
- That the use by bidder of criminal history background checks complies with the U.S. Equal Employment Opportunity Commission’s Enforcement Guidance on the Consideration of Arrest and Conviction Records in Employment Decisions and that the bidder has not had a determination rendered against it in the past 7 years that it discriminated against a person through the use of an individual’s arrest or criminal history.

I CERTIFY THAT THE ABOVE STATEMENTS ARE TRUE.

Date

Signature

Printed Name

Position

CITY OF KALAMAZOO
LOCAL PREFERENCE POLICY AND CERTIFICATION

The lowest responsive Kalamazoo County bidder whose bid is not low but falls within 2% of the lowest responsive bid is afforded the opportunity to become the successful bidder if it agrees to reduce its bid to match the lowest responsive bid. The City of Kalamazoo is the sole determiner whether a bidder is responsible, qualifies as a Kalamazoo County bidder, and if its bid is responsive to the City’s specifications, terms, and conditions.

If the lowest Kalamazoo County bidder chooses not to match the lowest bid, the next lowest responsive Kalamazoo County bidder whose bid falls within 2% of the lowest bid is given the opportunity to match the lowest responsive bid.

To qualify as a Kalamazoo County bidder, the bidder must meet both the following criteria:

1. Have a physical presence in Kalamazoo County by maintaining a permanent office, factory, or other facility in Kalamazoo County with employees working in Kalamazoo County.
2. Have paid real or personal property taxes related to said business to the City of Kalamazoo, County of Kalamazoo, or other municipal corporation within Kalamazoo County in the previous tax year, except that a non-profit entity need not meet this requirement.

This local preference policy applies only to purchases for materials, supplies, capital outlay, and services for maintenance, repair or operation of City facilities that are over \$25,000. If more than 50% of the contract is sub-contracted to firms located outside of Kalamazoo County that bid does not qualify for the local preference policy outlined above. The local preference policy will not apply if prohibited by law. The Purchasing Agent has the authority to finally determine if the bidder qualifies as a Kalamazoo County bidder as set forth herein. The Purchasing Agent may take into account the permanency of the business in Kalamazoo, and whether the business appears to be claiming to be a Kalamazoo County business solely or primarily to qualify as a Kalamazoo County business under this Resolution, and any other material factors.

CERTIFICATION

If you qualify as a Kalamazoo County bidder and wish to be considered for the local preference provisions as provided above, please certify that fact by providing the information requested below and attesting to its accuracy.

Firm Name: _____

Street Address of Business: _____

City, State, and Zip Code: _____

Number of employees working in Kalamazoo County: _____

Name the city or township to which business real and/or personal property taxes are paid or provide non-profit status: _____

The above information is accurate:

Signature: _____ Date: _____

Title: _____

SUB-CONTRACTING INFORMATION

Using the table below provide information regarding the sub-contractors that will be working to fulfill the requirements of this contract. Submit as complete a list as possible at the time of your bid. You will have two business days after the bid opening to update the list as needed. The information provided will be used for evaluating your bid and to assist in determining if you qualify as a Kalamazoo County Bidder.

INSTRUCTIONS:

Nature of Contract - State a brief description of the work or product that will be provided.

BIDDER – Provide the percentage of services or construction activity that will be provided by your firm.

Subcontractors:

- Provide the Name and Address for each subcontractor providing services or construction activities for this contract.
- Indicate with **YES** or **NO** under the “Local?” box if they qualify as a “Kalamazoo County bidder” (see local preference certification page)
- Provide the percentage for the dollar amount of the contract work they will be performing.

If there are not enough lines in the table below make additional copies as needed.

Nature of Contract:		
Subcontractor Name/Address	Local?	% Of Total Contract
BIDDER		

Does this List of Subcontractors need to be updated after the bid opening? **Yes** ___ **No** ___

REFERENCE QUESTIONNAIRE

Please answer the following questions completely.

1. Firm name: _____

2. Established: Year _____ Number of Employees: _____

3. Type of organization:

- a. Individual: _____ b. Partnership: _____
c. Corporation: _____ d. Other: _____

4. Former firm name(s) if any, and year(s) in business:

5. Include at least 3 references of contracts for similar work performed over the last five (5) years. Include: owner, contact person and phone number and description of work performed.

5.1 Company Name: _____

Address: _____

Phone: _____

Contact: _____

Type of work or contract: _____

5.2 Company Name: _____

Address: _____

Phone: _____

Contact: _____

Type of work or contract: _____

5.3 Company Name: _____

Address: _____

Phone: _____

Contact: _____

Type of work or contract: _____

I hereby certify that all of the information provided is true and answered to the best of my ability.

Signed: _____ Name: _____
(type or print)

Title: _____ Date: _____

CITY OF KALAMAZOO – INVITATION FOR BIDS
Academy Street Sidewalk Improvement

Page | 13
Bid Reference #: 91347-008.0

I hereby state that all the information I have provided is true, accurate and complete. I hereby state that I have the authority to submit this bid which will become a binding contract if accepted by the City of Kalamazoo. I hereby state that I have not communicated with nor otherwise colluded with any other bidder, nor have I made any agreement with nor offered/accepted anything of value to/from an official or employee of the City of Kalamazoo that would tend to destroy or hinder free competition.

The firm's identification information provided will be used by the City for purchase orders, payment, and other contractual purposes. If the contractual relationship is with, or the payment made to, another firm please provide a complete explanation on your letterhead and attach to your bid. Please provide for accounts payable purposes:

Tax Identification Number (Federal ID): _____

Remittance Address: _____

Financial Contact Name: _____ Financial Contact Phone Number: _____

Financial Contact Email Address: _____

I hereby state that I have read, understand, and agree to be bound by all terms and conditions of this bid document.

SIGNED: _____ NAME: _____
(Type or Print)

TITLE: _____ DATE: _____

FIRM NAME: _____
(If any)

ADDRESS: _____
(Street address) (City) (State) (Zip)

PHONE: _____ EMAIL: _____

FOR CITY USE ONLY - DO NOT WRITE BELOW

SECTION III
CITY OF KALAMAZOO
INDEMNITY AND INSURANCE

Contractor, or any of their subcontractors, shall not commence work under this contract until they have obtained the insurance required under this paragraph, and shall keep such insurance in force during the entire life of this contract. All coverage shall be with insurance companies licensed and admitted to do business in the State of Michigan and acceptable to the City of Kalamazoo within ten (10) days of the Notice of Award. The requirements below should not be interpreted to limit the liability of the Contractor. All deductibles and SIR's are the responsibility of the Contractor.

The Contractor shall procure and maintain the following insurance coverage:

Workers' Compensation Insurance including Employers' Liability Coverage, in accordance with all applicable statutes of the State of Michigan.

Commercial General Liability Insurance on an "Occurrence Basis" with limits of liability not less than \$1,000,000 per occurrence and aggregate. Coverage shall include the following extensions: (A) Contractual Liability; (B) Products and Completed Operations; (C) Independent Contractors Coverage; (D) Broad Form General Liability Extensions or equivalent, if not already included and (E) XCU coverage if the nature of the contract requires XC or U work.

Automobile Liability in accordance with all applicable statutes of the State of Michigan, with limits of liability not less than \$1,000,000 per occurrence, combined single limit for Bodily Injury, and Property Damage. Coverage shall include all owned vehicles, all non-owned vehicles, and all hired vehicles.

Additional Insured: Commercial General Liability and Automobile Liability, as described above, shall include an endorsement stating that the following shall be *Additional Insureds*: The City of Kalamazoo, all elected and appointed officials, all employees and volunteers, all boards, commissions, and/or authorities and board members, including employees and volunteers thereof. It is understood and agreed that by naming the City of Kalamazoo as additional insured, coverage afforded is considered to be primary and any other insurance the City of Kalamazoo may have in effect shall be considered secondary and/or excess.

To the fullest extent permitted by law the Contractor agrees to defend, pay on behalf of, indemnify, and hold harmless the City of Kalamazoo, its elected and appointed officials, employees, agents and volunteers, and others working on behalf of the City of Kalamazoo against any and all claims, demands, suits, or loss, including all costs connected therewith, and for any damages which may be asserted, claimed, or recovered against or from the City of Kalamazoo, by reason of personal injury, including bodily injury or death and/or property damage, including loss of use thereof, which arises out of, or is in any way connected or associated with this contract.

Cancellation Notice: All policies, as described above, shall include an endorsement stating that it is understood and agreed that thirty (30) days, or ten (10) days for non-payment of premium, Advance Written Notice of Cancellation, Non-Renewal, Reduction, and/or Material Change shall be sent to: City of Kalamazoo, Purchasing Division, 241 W. South Street, Kalamazoo, MI 49007.

Proof of Insurance Coverage: The Contractor shall provide the City of Kalamazoo at the time that the contracts are returned by him/her for execution, or within 10 days of Notice of Award, whichever is earlier, a Certificate of Insurance as well as the required endorsements. In lieu of required endorsements, if applicable, a copy of the policy sections where coverage is provided for additional insured and cancellation notice would be acceptable. Copies or certified copies of all policies mentioned above shall be furnished, if so requested.

INDEMNITY AND INSURANCE
Continued

If any of the above coverages expire during the term of this contract, the Contractor shall deliver renewal certificates and/or policies to City of Kalamazoo at least ten (10) days prior to the expiration date.

Scope of Coverage: The above requirements and conditions shall not be interpreted to limit the liability of the Contractor under this Contract, but shall be interpreted to provide the greatest benefit to the City and its officers and employees. The above listed coverages shall protect the Contractor, its employees, agents, representatives and subcontractors against claims arising out of the work performed. It shall be the Contractor's responsibility to provide similar insurance for each subcontractor or to provide evidence that each subcontractor carries such insurance in like amount prior to the time such subcontractor proceeds to perform under the contract.

SECTION IV
SPECIAL REQUIREMENTS

1. BID BOND/GUARANTEE

The bid must be accompanied by a bid bond which shall not be less than five (5%) percent of the total amount of the bid. No bid will be considered unless it is accompanied by the required guarantee. The bid guarantee shall ensure the execution of the bid and award, and the furnishing of a performance bond and a labor and material bond (A and B below) by the successful bidder. (Contractors Note: A cashier's or certified check in lieu of a bid bond is **NOT** acceptable.)

A. PERFORMANCE BOND

A performance bond shall be furnished in the full amount of the contract ensuring the City of faithful performance of all the provisions of the contract, and the satisfactory performance of any equipment required hereunder. The bond shall also ensure the City against defective workmanship and/or materials.

B. LABOR AND MATERIAL (PAYMENT) BOND

A labor and material (payment) bond shall be furnished for the period covered by the contract, in the full amount of the contract for the protection of labor and material suppliers and sub-contractors.

Bonds shall be secured by a guaranty or a surety company listed in the latest issue of the U.S. Treasury, circular 570, and licensed to do business in the State of Michigan, and written in favor of the City of Kalamazoo. The amount of such bonds shall be within the maximum amount specified for such company in said circular 570. The bonds shall be accompanied by a power of attorney showing authority of the bonding agent to sign such bonds on behalf of the guaranty or surety company. The cost of the bonds shall be borne by the Contractor.

Failure of the Contractor to supply the required bonds within ten (10) days after Notice of Award, or within such extended period as the Purchasing Agent may agree to, shall constitute a default and the City of Kalamazoo may either award this contract to the next lowest bidder or re-advertise for bids and may charge against the Contractor for the difference between the amount of the bid and the amount for which a contract for the work is subsequently executed, irrespective of whether the amount thus due exceeds the amount of the bid bond. If a more favorable bid is received by re-advertising, the defaulting bidder shall have no claim against the City of Kalamazoo for a refund.

2. WAIVERS OF LIEN

Upon completion of all work and request for final payment, the Contractor shall furnish a 100% waiver of lien from each supplier and sub-contractor covering all items of the work. Failure to supply waivers of lien for the entire job upon completion and final payment request will be considered grounds for withholding final payment.

3. SUBCONTRACTORS

- A. Contractors shall state on the Bid and Award page any and all subcontractors to be associated with their bid, including the type work to be performed. Any and all subcontractors shall be bound by all of the terms, conditions and requirements of the contract; however, the prime contractor shall be responsible for the performance of the total work requirements.

- B. The Contractor shall cooperate with the City of Kalamazoo in meeting its commitments and goals with regard to maximum utilization of minority and women business enterprise, and shall use its best efforts to ensure that minority and women business enterprises have maximum practicable opportunity to compete for subcontract work under this agreement.

SECTION V
SPECIAL CONDITIONS

1. INTENT

It is the intent of these plans and specifications to provide for a general contractor who shall provide all labor, materials, tools and equipment necessary to perform in a professional manner for the **ACADEMY STREET SIDEWALK IMPROVEMENT** as described in the specifications and bid document.

2. SCOPE OF WORK

The scope of work for this project shall consist of

- **Removal of Existing Sidewalk:**
Demolition and removal of the current concrete sidewalk panels along both sides of Academy Street (specific limits to be defined in the field or per plan). This includes disposal of old materials in compliance with city and environmental regulations.
- **Site Preparation:**
Grading and compaction of the subgrade to ensure proper slope, drainage, and ADA-compliant cross slopes. Adjustments may be made to match adjacent property entrances, driveways, or curbs.
- **Installation of New Sidewalk:**
Construction of new concrete sidewalk panels at the same location, following City of Kalamazoo standard sidewalk specifications and ADA accessibility guidelines. New sidewalk will match existing conditions except at northeast corner of Academy and Church, where radius will be reduced (as shown in plans).
- **Curb Ramps and Transitions**
Reconstruction or modification of curb ramps at intersections and driveways to ensure full ADA compliance. Detectable warning surfaces will be installed where required.
- **Traffic Control:**
Temporary traffic and pedestrian control will be implemented throughout the duration of the project to ensure public safety and minimize disruption. All signage, barriers, and detours will follow MUTCD and city standards.
- **Restoration:**
Disturbed areas adjacent to the sidewalk will be restored with topsoil, seed, and mulch or other applicable treatments to match existing conditions.

All necessary traffic control, labor, materials, tools, equipment, and other items incidental to the work being performed shall be included in the Contractor's unit price for this contract. Such items will not be bid or paid for separately but shall be included in the overall unit price.

The bidder shall furnish all labor, supervision, supplies, tools, equipment, and other means necessary or proper for performing and completing the work. The bidder shall be responsible for the cleaning up of the job site and shall repair or restore all structures and property that may be damaged or disturbed during performance of the work to the satisfaction of the Public Services Department for the City of Kalamazoo. Drainage structure covers shall be salvaged and reused if in usable condition; otherwise, they shall be replaced. Where needed, all traffic control used for such operations as defined by the MMUTCD will be the responsibility of the bidder.

The bidder shall have all work completed by November 1, 2025.

3. UNIT PRICING

The unit price, including its pro rata share of overhead, multiplied by the quantity shown shall represent the total bid and shall be held firm for the life of this contract. Any bid not conforming to this requirement may be rejected as non-responsive.

4. TEMPORARY UTILITIES

- 4.1 Temporary or construction water will NOT be available on the sites. The Contractor must provide for drinking water.
- 4.2 Temporary toilets: To be supplied by the Contractor as may be necessary.

5. PROGRESS SCHEDULE

- 5.1 Work shall start no earlier than receipt of notification by Contractor of Notice to Proceed from the City.
- 5.2 Project shall have a **final completion date no later than November 1, 2025.**
- 5.3 Work of a similar nature may be added to this contract if agreed to by the City and the Contractor. In the event that work is added, the progress schedule for the existing work will remain unchanged. Any contract time added for additional work will be applied to that additional work only and cannot be added to items in the original contract. Any work done on the items in the original contract past the number of working days stated herein will be subject to liquidated damages regardless of any work that may be added at a later date.
- 5.4 The Contractor will be required to meet with the Public Services representatives to work out a detailed progress schedule. The schedule for this meeting will be within two weeks after contract award has been made.
- 5.5 The named sub contractor(s) for all items shall also be present at the scheduled meeting and be required to sign the Progress Schedule to indicate their approval of the scheduled dates of work set forth in the Progress Schedule. If unable to attend the scheduled meeting, the sub-contractor shall, at a minimum, sign the Progress Schedule to indicate their approval of the dates of work. MDOT Form 1130 shall be used for schedule submission and signature of all parties.
- 5.6 The Progress Schedule shall include, as a minimum, the starting and completion dates for major items, and where specified in the bid document the date the project is to be opened to traffic as well as the final project completion date specified in the bid document. The Progress Schedule shall be coordinated with all aspects of the work occurring at the site.
- 5.7 Failure on the part of the Contractor to carry out the provisions of the Progress Schedule as established may be considered sufficient cause to prevent bidding future projects until a satisfactory rate of progress is again established.
- 5.8 The starting date and the contract time to the completion date for this project may be adjusted by Public Services without imposing liquidated damages upon the receipt of satisfactory documented evidence that unforeseen delayed delivery of critical materials will prevent the orderly prosecution of the work.
- 5.9 Any request extension of the completion date and satisfactory documented evidence of unforeseen delays shall be submitted via MDOT Form 1100A – Extension of Contract Time.
- 5.10 MDOT Standard Specifications for Construction Section 501.03.I.1, Weather Limitations, shall apply.

6. LIQUIDATED DAMAGES

Liquidated Damages will be assessed per Section 108.10C of the MDOT Standard Specifications for Construction.

7. MAINTAINING TRAFFIC

- 7.1 This work shall be in accordance with the requirements of Section 812 of the MDOT Standard Specifications for Construction, the Maintaining Traffic special provision, and as specified herein. The Contractor is advised that the current Michigan Manual of Uniform Traffic Control Devices (MMUTCD) is hereby established as governing all work in connection with traffic control devices, barricade lighting, etc. required on this project.
- 7.2 The Contractor shall furnish, erect, maintain and, upon completion of the work, remove all traffic control devices and barricade lights within the project and around the perimeter of the project for the safety and protection of through and local traffic. This includes, but is not limited to: Advance, regulatory and warning signs; barricades and channeling devices at intersecting streets on which traffic is to be maintained; barricades at the ends of the project and at right of way lines for intersecting streets which are to be closed with the first usable street on each side of the project. Traffic regulators, where required by the Engineer, are included.
- 7.3 Where the existing pavement or partial widths of new pavement are to be utilized for the maintenance of through and local traffic, channelizing devices will be required at 50' intervals or as directed by the Engineer for channeling and directing traffic through the construction area.
- 7.4 Through traffic shall be maintained utilizing sidewalk closures with detours and traffic shifts per MDOT traffic and safety details.
- 7.5 Protection of all pedestrian traffic shall be maintained at all times in accordance with the MMUTCD. Type II barricades and sidewalk detour signs shall be used in accordance with the MMUTCD at all intersections and ramps. Sidewalk detours shall direct pedestrians safely around closed sidewalk locations and shall be placed at the nearest pedestrian crossing locations still open to traffic.
- 7.6 Payment for furnishing and operating all temporary traffic control devices and traffic regulators shall be paid as pay items included in this contract and shall include all the temporary traffic control measures on all road segments.
- 7.7 Under Article 812.04.D "Operated Pay Items" the term 'Relocating' shall include the relocating of the item from any street covered by the contract to any other street covered by the contract.
- 7.8 No work shall be allowed on the following dates:
 - 9/1/25 Labor Day Holiday
 - 11/11/25 Veteran's Day
 - 11/27/25 Thanksgiving
 - 12/25/25 Christmas
 - 1/1/26 New Year's Day
- 7.9 Milled surfaces will not be allowed on travel lanes for longer than 72 hours unless approved by the Project Manager. Any traffic surface within the construction area containing a drop off at the edge of a pavement greater than two (2) inches shall not be allowed to be opened to the public without proper wedging of the edges according to the COK standard detail. Any areas not conforming to the road levelness and profile shall be signed appropriately in accordance with the MMUTCD and best management practices.
- 7.10 Once work is initiated that includes lane restrictions or detours, that work shall be continuous until complete. If work is suspended for more than three (3) continuous working days all lane restrictions and detours shall be removed at the Contractor's expense.

MAINTAINING TRAFFIC (Cont.)

Special Restrictions: Access to frontage properties shall be maintained as much as practical. Emergency access shall be maintained at all times. The Contractor shall maintain two way traffic with flag control as needed when the road is restricted to only one traffic lane.

Pedestrian Access shall be maintained for:

First Congregational Church: Ped entrances shown as (3) yellow dots below. At least one (1) shall be accessible at all times.

Children's Nature Playscape: Ped entrance shown as red dot below. Coordinate all workdays with Engineer that will render main entrance inaccessible. Accessibility to main entrance must be maintained on weekends.

Bronson Park: Ped entrances shown as 4 blue dots below. Maintain pedestrian access to the highest degree practicable.



8. COORDINATING

The Contractor's attention is called to Article 104.08 of the MDOT Standard Specifications for Construction entitled "Cooperation by Contractor" and the special provisions contained within this contract.

9. WORK HOURS

All work shall be done between the hours of 7 am to 7 pm (Monday – Saturday). Work done outside of these times will be at the discretion of the Project Manager.

No work shall be done on Sunday, unless otherwise approved by the Project Manager in writing.

The Contractor shall conduct their work in such a manner that no excavations are left open overnight. If this is not possible, the Contractor shall provide and install a temporary fence to protect the excavation, at the Contractor's expense.

SECTION VI
GENERAL CONDITIONS

1. PROJECT MANAGER’S STATUS

The City Engineer (Engineer) or his/her duly authorized representative shall be the City’s Project Manager and shall have the duties and responsibilities as provided in the contract.

The Project Manager shall have the authority to reject any work or materials which do not conform to the contract and to decide questions or interpretations which may arise from the contract documents.

The Contractor shall immediately report to the Project Manager any questionable or obvious error or omission which may be apparent in the contract documents and shall not proceed with work until the Project Manager has resolved the error or omission.

2. CONSTRUCTION SCHEDULE AND COORDINATION

- 2.1 The Contractor shall supply the City with an agreeable construction schedule before commencing work on this contract. This schedule shall detail beginning and completion dates for each major component of the project.
- 2.2 The Contractor shall coordinate and cooperate with all other contractors who may be working on the site, to allow for the orderly progress of work being done.
- 2.3 The Contractor is required to keep the Project Manager fully informed of any proposed work which will tend to interfere with the existing operations at the site.
- 2.4 The Contractor shall schedule all work to accommodate the City's schedule. In the event the Contractor's schedule falls on weekends, nights or overtime work is required, no additional compensation will be allowed. All work shall be part of this contract without regard to when it is done.
- 2.5 The Contractor shall coordinate with other construction projects and contractors adjacent to the location of this project.
- 2.6 The Contractor shall notify, by door hanger/written flier (pre-approved by the Project Manager), affected residents and business of work and areas to be disturbed by construction at least 72 hours in advance. Work shall not commence until the affected residents/business have been notified and given advanced notice. The Contractor shall work to minimize impacts to those affected by the construction while still maintaining project schedule and objectives. For impacts to driveways or property access points that affect residents or businesses, resident/business shall be notified 24 hours in advance of the work taking place and coordinated with for parking and property access.

3. PROTECTION OF WORK

The Contractor shall maintain adequate protection of all his/her work from damage and shall protect all public and private abutting property from injury or loss arising in connection with this contract.

4. PROTECTION OF PROPERTY

- 4.1 The Contractor shall confine his/her equipment and operations to those areas of the work site necessary for the completion of the work, or as authorized by the Project Manager. The Contractor shall protect and preserve from damage any facilities, utilities or features including trees, shrubs and turf which are not required to be disturbed by the requirements of the work.
- 4.2 The Contractor shall be responsible to determine the location of and to protect from damage any utilities or other improvements.

5. REMOVAL OF RUBBISH

The Contractor shall daily remove all rubbish and accumulated materials due to his/her construction.

6. BRICK SIDEWALK OR PAVEMENT REMOVAL

When brick is removed from City of Kalamazoo sidewalk or pavement it shall be salvaged, unless otherwise stated in the contract. Brick to be salvaged shall be placed within the right-of-way (ROW) for pickup by the City. Brick shall not be placed or stored on any pavement, sidewalk, bike, or pedestrian areas but in ROW green space only; salvaged brick shall not be placed on private property without written approval given by the owner.

7. REMOVAL OF PERMANENT TRAFFIC SIGNS AND POSTS

The Contractor shall notify the Project Manager five (5) working days in advance of the time permanent signs must be removed to accommodate the construction. The Contractor shall remove and salvage any permanent signs that must be removed for construction.

8. PERMANENT TRAFFIC SIGN STAKING

The City shall stake the field locations for the new permanent traffic signs that the Contractor shall install under this contract. The Contractor shall call MISS DIG to arrange for staking prior to sign installation.

9. LAWN SPRINKLER SYSTEMS

- 9.1 Owners of known lawn sprinkler systems shall be notified by the contractor a minimum of 72 hours in advance of any work to be done that will affect those systems. Modifications to the systems are the responsibility of the owners and are not a part of this contract.
- 9.2 Owners of lawn sprinkler systems that were unknown to the contractor at the beginning of work and uncovered during the work for this contract, shall be notified as soon as possible and no later than 24 hours after discovery of the system. The Contractor shall coordinate with the owner for placement outside the immediate work area until modifications can take place. Modifications to the systems are the responsibility of the owners and are not a part of this contract.

10. SALVAGING DRAINAGE STRUCTURE COVERS

The City of Kalamazoo reserves the right to salvage any drainage structure covers or portions thereof which are to be removed as a result of work done under this contract. Any covers which are to be salvaged will be identified by the City. The contractor will set those items identified aside for pick up by City personnel.

11. REMOVING AND REPLACING CURB AND GUTTER

When the contract provides for streets to be milled and resurfaced, or when the existing base course is to remain in place, and replacement of curb and gutter is called for, milling or other surface removal operations will not take place until placement of the new curb and gutter, and adjacent concrete base course has been completed.

12. DRAINAGE INLET COVERS (K COVERS)

In compliance with the Clean Water Act, all inlet covers must have on their backs reminders against dumping waste into the drains.

13. FLY ASH USE IN CONCRETE ITEMS

The use of fly ash, as described in Section 901.07 of the MDOT Standard Specifications for Construction, shall not be allowed.

14. EXISTING WATER MAINS

The Contractor will be responsible for any damage to the existing water mains during the work required under this contract. This includes but is not limited to the construction of the proposed storm sewers, catch basins, leaching basins, leaching trenches, subgrade under drains, subgrade undercutting, full depth repairs, or other miscellaneous work.

15. GRADE INTERSECTIONS

All intersections are to be considered as complete units and their grades determined before construction is started.

16. UNDERGROUND UTILITIES

For protection of underground utilities, the Contractor shall dial Miss Dig at 1-800-482-7171 a minimum of 72 hours prior to excavating in the vicinity of utility lines. All “Miss Dig” participating members will thus be routinely notified. This does not relieve the Contractor of notifying utility owners who may not be part of the “Miss Dig” alert system.

17. ADJUSTING MONUMENT BOXES

It is the intent that all government corners on this project be preserved and that, where necessary, monument boxes be placed or adjusted whether shown or not.

18. PAVEMENT REMOVAL QUANTITIES

Pavement removal as called for in this proposal shall be at the discretion of the Project Manager. If, in his/her judgment, areas of pavement may be left in place or additional area added to provide the proper cross-section and base, adjustments can be made in the quantities.

19. COLD MILLING

In those locations where cold milling is called for and the existing curb is to remain in place, the cold milling item shall cover removal of all asphalt up to the face of the curb. Any materials which are left due to the inability of the cold milling machine to work immediately adjacent to the face of the curb will be removed to the depth indicated on the typical cross-section by other means approved by the Project Manager. Any extra work involved in removing said HMA material shall be considered incidental to the item of Cold Milling HMA Surface.

20. SITE SECURITY

The Contractor shall be responsible for job site security of all materials and tools provided by him/her and no claim for loss or damage will be considered by the City.

21. SITE ACCESS

The City will provide fair and reasonable access to the job site within the working schedules of both parties.

22. MATERIALS INSPECTION AND RESPONSIBILITY

- 22.1 The Project Manager shall have the right to inspect any materials to be used in carrying out the terms of the contract.

MATERIALS INSPECTION AND RESPONSIBILITY (Cont.)

- 22.2 The City does not assume any responsibility for the contracted quality and standard of all materials, equipment, components or completed work furnished under this contract.
- 22.3 Any materials, equipment, components or completed work which does not comply with contract specifications, MDOT, or state codes may be rejected by the City, and shall be replaced by the Contractor at no cost to the City.
- 22.4 Any materials, equipment or components rejected shall be removed within a reasonable period of time from the premises of the City at the entire expense of the Contractor after written notice has been mailed by the City to the Contractor that such materials, equipment or components have been rejected.

23. GUARANTEE

The Contractor shall guarantee all of his/her work for a period of one (1) year following the date of final acceptance of the completed work and shall repair, replace or make good any materials or work which fail to function or perform or be found defective, without cost to the city.

24. SAFETY

The Contractor shall comply with all applicable OSHA and MIOSHA regulations.

25. SPECIFICATIONS FOR CONSTRUCTION

The items of work in this contract shall conform to the Michigan Department of Transportation (MDOT) 2020 Standard Specifications for Construction, MDOT Supplemental Specifications, and/or the City of Kalamazoo Standard Specifications unless superseded by a Special Provision contained in this document.

26. QUANTITIES

The quantities shown on the Bid and Award pages are approximate only and may be subject to increase or decrease. No guarantee of maximum or minimum is given.

27. PRICE

The unit price, including its pro rata share of overhead, multiplied by the quantity shown shall represent the total bid and shall be held firm for the life of this contract. Any bid not conforming to this requirement may be rejected as non-responsive. Special attention of all bidders is called to this provision since if conditions make it necessary to revise the quantities, no limit will be fixed for such increased or decreased quantities, nor extra compensation allowed; provided the net monetary value of all such additive and subtractive changes in quantities of such items of work, i.e., difference in cost, shall not increase or decrease the original contract price by more than twenty five (25) percent. Some items of work might be increased beyond the 25% limitations as spelled out previously, upon mutual agreement.

28. BASIS FOR PAYMENT

Payment shall be based on the bid unit price for each work item and the approved constructed quantity for that work item. Due to potential differences in conditions between the plans and the field, final as built quantities may be different than contained in the bid document. The City does not guarantee quantities and will pay only for "as built" quantities approved by the Project Manager or his representative. Quantities in excess of those approved shall be at the Contractor's own expense, the City will not be responsible for excess quantities not approved. Should an item of work have to be redone, such as replacing new walk because the Contractor failed to adequately protect the wet concrete from rain or pedestrian or vehicular damage, such work shall be replaced at the Contractor's expense. Should changes in design result in the Project Manager directing the removal and reinstallation of already completed work prior to final completion and acceptance of the project, such removal and installation shall be paid for based on as-bid unit prices and the quantities removed and installed.

29. PAY ESTIMATES

The Contractor shall be responsible for the generation of invoices for payment. Payment will be generated by the City based upon an approved invoice. Frequency of payment shall be monthly unless agreed to otherwise by the Project Manager, with the invoiced period ending on the last day of the month. However, if a different frequency is approved by the Project Manager, it shall not exceed bi-weekly invoicing.

30. PAYMENT TO CONTRACTOR

The Project Manager will be responsible for approving all measured quantities of work. Once measured quantities are approved, the Contractor shall submit a pay invoice to the City of Kalamazoo Attn: Accounts Payable at 241 West South Street, Kalamazoo MI, 49007 or apinvoice@kalamazoo.org. The contractor is required to meet with the Project Manager to verify final constructed quantities within 60 days of project completion. In the event of a disagreement the Project Manager's measured quantities shall be considered final.

31. INSPECTION OF WORK

The City may maintain inspectors on the job who shall, at all times, have access to work.

32. INSPECTION OF SITE

Each bidder shall visit the site of the proposed work and fully acquaint himself/herself with the existing conditions relating to construction, labor, and shall fully inform himself/herself as to the facilities involved and the difficulties and restrictions attending the performance of this contract. The bidder shall thoroughly examine and become familiar with the drawings, specifications, and all other bid/contract documents. The Contractor, by the execution of this contract, shall in no way be relieved of any obligation under it due to his failure to receive or examine any form or legal instrument, or to visit the site and acquaint himself/herself with the conditions there existing. No allowance shall be made subsequently in this connection on behalf of the Contractor for any negligence of his/her part. For inspection call the Public Services Department, Engineering Division.

33. LAYING OUT OF WORK

Before submitting a bid, the Contractor shall verify all measurements and shall be responsible for the correctness of same. No extra charge or compensation will be allowed on account of differences between actual dimensions and the measurements indicated on the drawings. Any difference that may be found shall be submitted to the City Engineer for consideration before proceeding.

34. SUPERVISION

The Contractor shall employ an experienced superintendent or foreperson on the job at all times.

35. TARDINESS

Construction delays resulting from tardiness on the part of the Contractor will be reviewed by the City in the event of any request for contract extension by the Contractor.

36. ADDITIONS

Any modification to the contract shall be subject to prior approval by the Purchasing Agent. City Commission approval may also be required.

Prices for additional work required are not requested in the itemized listing contained herein for the base project. Should additional work be authorized, compensation shall be made on the basis of price or prices to be mutually agreed upon. Such additional work shall not begin until a Change Order has been approved.

37. INSPECTION AND TESTING

The Contractor shall give the Project Manager timely notice of readiness of the work for all required inspections, tests or approvals, and shall cooperate with inspections and testing personnel to facilitate required inspections or tests.

38. QUESTIONS

Bidders shall address questions regarding the specifications to Mohith Reddy Kondlapudi at kondlapudim@kalamazoocity.org or 269-360-2977. (This does not relieve the requirements of Page 5, Item 3). Questions regarding terms, conditions and other related bid requirements may be addressed to Kyle Dunn, Buyer at (269) 337-8720 or dunnk@kalamazoocity.org.

SECTION VII
TERMS AND CONDITIONS

1. AWARD OF CONTRACT

- 1.1. This contract will be awarded to that responsible bidder whose bid, conforming to this solicitation, will be most advantageous to the City, price and other factors considered. The City reserves the right to accept or reject any or all bids and waive informalities and minor irregularities in bids received. Other factors include, as an example but not limited to, delivery time, conformance to specifications, incidental costs such as demurrage and deposits, etc.

Notification of award will be in writing by the Purchasing Agent. Upon notification, the Contractor shall submit to the Purchasing Division all required insurance certificates (if required) and such other documentation as may be requested or required hereunder. Upon their receipt and subsequent approval by the City, the Purchasing Agent will forward to the Contractor a written **NOTICE TO PROCEED**. Work shall **NOT** be started until such **NOTICE TO PROCEED** is received by the Contractor.

- 1.2. Unilateral changes in bid prices by the bidder shall not be allowed. However, the City, at its sole option, reserves the right to negotiate with bidders in the event of, but not limited to:

- 1.2.1 No bids received;
- 1.2.2 A single bid being received; or
- 1.2.3 Prices quoted are over budget and/or unreasonable.

2. COMPLETE CONTRACT

This bid document together with its addenda, amendments, attachments, and modifications, when executed, becomes the complete contract between the parties hereto, and no verbal or oral promises or representations made in conjunction with the negotiation of this contract shall be binding on either party.

3. SUBCONTRACTORS – NON-ASSIGNMENT

Bidders shall state in writing any and all sub-contractors to be associated with this bid, including the type of work to be performed. The Contractor shall cooperate with the City of Kalamazoo in meeting its commitments and goals regarding maximum utilization of minority and women-owned business enterprises.

The Contractor hereby agrees and understands that the contract resulting from this solicitation shall not be transferred, assigned, or sublet without prior written consent of the City of Kalamazoo.

4. TAXES

The City of Kalamazoo is exempt from all federal excise tax and state sales and use taxes.

5. INVOICING

All original invoice(s) will be sent to the Financial Services Division, 241 W. South Street, Kalamazoo, MI 49007 or via email at apinvoice@kalamazoocity.org. The Finance Division processes payments after receipt of an original invoice from the Contractor and approval by the department. The City of Kalamazoo's policy is to pay invoice(s) within 30 days from the receipt of the original invoice if the services or supplies are satisfactory and the proper paperwork and procedures have been followed. **In order to guarantee payment to the vendor on a timely basis, the vendor needs to receive a purchase order number before supplying the City of Kalamazoo with goods or services.** All original, and copies of original invoice(s), will clearly state which purchase order they are being billed against.

INVOICING (Cont.)

The City of Kalamazoo is a government municipality and therefore is tax exempt from all sales tax.

The vendor is responsible for supplying the Finance Division with a copy of their W9 if they are providing a service to the City of Kalamazoo.

6. PAYMENTS

Upon issuance of certificates of Payment by the Architect/Engineer for labor and material incorporated in the work and the materials suitably stored at the site payment shall be made up to ninety (90%) percent of the value thereof.

When the cumulative total of payment is equal to fifty (50%) percent of the contract sum, subsequent payments will be made in the full amount for labor and material certified by the Architect/Engineer.

The amount retained shall be held until final acceptance of the work, receipt of all payrolls, releases, and waiver of liens.

7. CHANGES AND/OR CONTRACT MODIFICATIONS

The City reserves the right to increase or decrease quantities, service or requirements, or make any changes necessary at any time during the term of this contract, or any negotiated extension thereof. Price adjustments due to any of the foregoing changes shall be negotiated and mutually agreed upon by the Contractor and the City.

Changes of any nature after contract award which reflect an increase or decrease in requirements or costs shall not be permitted without prior approval by the Purchasing Agent. City Commission approval may also be required.

ANY CHANGES PERFORMED IN ADVANCE OF PURCHASING AGENT APPROVAL, MAY BE SUBJECT TO DENIAL AND NON-PAYMENT.

8. LAWS, ORDINANCES AND REGULATIONS

The Contractor shall keep himself/herself fully informed of all local, state, and federal laws, ordinances and regulations in any manner affecting those engaged or employed in the work and the equipment used. Contractor and/or employees shall, at all times, serve and comply with such laws, ordinances and regulations.

Any permits, licenses, certificates, or fees required for the performance of the work shall be obtained and paid for by the Contractor.

This contract shall be governed by the laws of the State of Michigan.

9. RIGHT TO AUDIT

The City or its designee shall be entitled to audit all the Contractor's records, and shall be allowed to interview any of the Contractor's employees, throughout the term of this contract and for a period of three years after final payment or longer if required by law to the extent necessary to adequately permit evaluation and verification of:

- A. Contractor compliance with contract requirements,
- B. Compliance with provisions for pricing change orders, invoices or claims submitted by the Contractor or any of his payees.

10. HOLD HARMLESS

If the negligent acts or omissions of the Contractor/Vendor or its employees, agents or officers, cause injury to person or property, the Contractor/Vendor shall indemnify and save harmless the City of Kalamazoo, its agents, officials, and employees against all claims, judgments, losses, damages, demands, and payments of any kind to persons or property to the extent occasioned from any claim or demand arising therefrom.

11. DEFAULT

The City may at any time, by written notice to the Contractor, terminate this contract and the Contractor's right to proceed with the work, for just cause, which shall include, but is not limited to the following:

- A. Failure to provide insurance and bonds (when called for), in the exact amounts and within the time specified or any extension thereof.
- B. Failure to make delivery of the supplies, or to perform the services within the time specified herein, or any extension thereof.
- C. The unauthorized substitution of articles for those bid and specified.
- D. Failure to make progress if such failure endangers performance of the contract in accordance with its terms.
- E. Failure to perform in compliance with any provision of the contract.
- F. **Standard of Performance** - Contractor guarantees the performance of the commodities, goods or services rendered herein in accordance with the accepted standards of the industry or industries concerned herein, except that if this specification calls for higher standards, then such higher standards shall be provided.

Upon notice by the City of Contractor's failure to comply with such standards or to otherwise be in default of this contract in any manner following the Notice to Proceed, Contractor shall immediately remedy said defective performance in a manner acceptable to the City. Should Contractor fail to immediately correct said defective performance, said failure shall be considered a breach of this contract and grounds for termination of the same by the City.

In the event of any breach of this contract by Contractor, Contractor shall pay any cost to the City caused by said breach including but not limited to the replacement cost of such goods or services with another Contractor.

The City reserves the right to withhold any or all payments until any defects in performance have been satisfactorily corrected.

In the event the Contractor is in breach of this contract in any manner, and such breach has not been satisfactorily corrected, the City may bar the Contractor from being awarded any future City contracts.

- G. All remedies available to the City herein are cumulative and the election of one remedy by the City shall not be a waiver of any other remedy available to the City.

12. TERMINATION OF CONTRACT

The City may, at any time and without cause, suspend the work of this contract for a period of not more than ninety days after providing notice in writing to the Contractor. The Contractor shall be allowed an adjustment in the contract price or an extension of the contract times, or both, directly attributable to the suspension if Contractor makes an approved claim.

The City may, without prejudice to any other right or remedy of the City, and with or without cause, terminate the contract by giving seven days written notice to the Contractor. In such case the Contractor shall be paid, without duplication, for the following items:

TERMINATION OF CONTRACT (Cont.)

- A. Completed and acceptable work executed in accordance with the contract documents prior to the effective date of termination, including fair and reasonable sums for overhead and profit on such work;
- B. Expenses sustained prior to the effective date of termination in performing services and furnishing labor, materials or equipment as required by the contract documents in connection with uncompleted work, plus fair and reasonable sums for overhead and profit on such expenses;
- C. All documented claims, costs, losses, and damages incurred in settlement of terminated contracts with Subcontractors, Suppliers, and others; and
- D. Reasonable expenses directly attributable to termination.

The Contractor shall not be paid on account of loss of anticipated profits or revenue or other economic loss arising out of or resulting from such termination.

13. INDEPENDENT CONTRACTOR

At all times, the Contractor, any of his/her employees, or his/her sub-contractors and their subsequent employees shall be considered independent contractors and not as City employees. The Contractor shall exercise all supervisory control and general control over all workers' duties, payment of wages to Contractor's employees and the right to hire, fire and discipline their employees and workers. As an independent contractor, payment under this contract shall not be subject to any withholding for tax, social security or other purposes, nor shall the Contractor or his/her employees be entitled to sick leave, pension benefit, vacation, medical benefits, life insurance or workers' unemployment compensation or the like.

14. PROJECT SUPERVISOR

The Contractor shall employ an individual to act as Project Supervisor. The Project Supervisor shall be available to the Contractor's workers and the Project Manager at all times by use of a beeper or other reliable means. The Project Supervisor shall prepare daily work plans for the employees, monitor employee performance, attendance, and punctuality; and work closely with the City's Project Manager in assuring contract compliance.

15. MEETINGS

The Contractor and/or Project Supervisor shall be available to meet with the Department Head or Project Manager at a mutually agreeable time to discuss problems, issues or concerns relative to the contract. Either party may call a meeting at any time. When such a request for a meeting is made, the meeting date shall, in no case exceed five (5) working days after the request; and, if in the sole opinion of the Department Head, the severity of the circumstance warrants, no more than one (1) working day.

16. INSPECTION OF WORK SITE

Before submitting bids or quotes for work, the Contractor shall be responsible for examining the work site and satisfying himself/herself as to the existing conditions under which he/she will be obligated to operate, or that in any way affects the work under this contract. No allowance shall be made subsequently, on behalf of the Contractor, for any negligence on his/her part.

17. CONTRACT PERIOD, EXTENSIONS, CANCELLATION

- A. The contract shall be in effect for the term stated in the specifications.
- B. The City may opt to extend this contract upon mutual agreement of both parties. The number of extensions shall be limited to that stated in the specifications.
- C. The City may, from time to time, find it necessary to continue this contract on a month-to-month basis only, not to exceed a six (6) month period. Such month-to-month extended periods shall be by mutual agreement of both parties, with all provisions of the original contract or any extension thereof remaining in full force and effect.
- D. All contracts, extensions and cost increases are subject to availability of funds and the approval of the City Commission (if required).
- E. The City reserves the right to cancel the contract due to non-appropriation of funds by the City with thirty (30) days written notice.
- F. Either party may terminate the contract (or any extension thereof) without cause at the end of any twelve (12) month term by giving written notice of such intent at least 60 days prior to the end of said twelve (12) month term.
- G. All notices are in effect commencing with the date of mailing. Written notices may be delivered in person or sent by First Class mail; or emailed to the last known address.
- H. If cancellation is for default of contract due to non-performance, the contract may be canceled at any time (see Item 11, DEFAULT)

APPENDIX A
NON-DISCRIMINATION CLAUSE FOR ALL CITY OF KALAMAZOO CONTRACTS

The Contractor agrees to comply with the Federal Civil Rights Act of 1964 as amended; the Federal Civil Rights Act of 1991 as amended; the Americans With Disabilities Act of 1990 as amended; the Elliott-Larson Civil Rights Act, Act. No. 453, Public Act of 1976 as amended; the Michigan Handicappers Civil Rights Act, Act No. 220, Public Act of 1976 as amended, City Ordinance 1856 and all other applicable Federal and State laws. The Contractor agrees as follows:

1. The Contractor will not discriminate against any employee or applicant for employment because of race, color, religion, national origin, sex, age, height, weight, marital status, physical or mental disability, family status, sexual orientation or gender identity that is unrelated to the individual's ability to perform the duties of the particular job or position. Such action shall include, but not be limited to the following: employment, upgrading, demotion or transfer, recruitment advertising, layoff or termination; rates of pay or other forms of compensations; and selection for training, including apprenticeship.
2. The Contractor will, in all solicitations or advertisements for employees placed by or on behalf of the Contractor, state that all qualified applicants will receive consideration for employment without regard to race, color, religion, national origin, sex, age, height, weight, marital status, physical or mental disability family status, sexual orientation or gender identity that is unrelated to the individuals ability to perform the duties of the particular job or position.
3. If requested by the City, the Contractor shall furnish information regarding practices, policies and programs and employment statistics for the Contractor and subcontractors. The Contractor and subcontractors shall permit access to all books, records and accounts regarding employment practices by agents and representatives of the City duly charged with investigative duties to assure compliance with this clause.
4. Breach of the covenants herein may be regarded as a material breach of the contract or purchasing agreement as provided in the Elliott-Larsen Civil Rights Act and City Ordinance 1856.
5. The Contractor will include or incorporate by reference the provisions of the foregoing paragraphs 1 through 4 in every subcontract or purchase order unless exempted by the rules, regulations or orders of the Michigan Civil Rights Commission* and will provide in every subcontract or purchase order that said provision will be binding upon each subcontractor or seller.
6. The Contractor will not preclude a person with a criminal conviction from being considered for employment unless otherwise precluded by federal or state law. (for contracts over \$25,000)

The Elliott-Larson Civil Rights Act, Sec. 202 of Act. No. 453 of 1976 reads in part as follows:

Sec. 202. (1) An employer shall not:

- (a) Fail or refuse to hire, or recruit, or discharge or otherwise discriminate against an individual with respect to employment, compensation, or a term condition or privilege of employment because of religion, race, color, national origin, age, sex, height, weight or marital status.
- (b) Limit, segregate or classify an employee or applicant for employment in a way which deprives or tends to deprive the employee or applicant of an employment opportunity or otherwise adversely affects the status of an employee or applicant because of religion, race, color, national origin, age, sex, height, weight or marital status.
- (c) Segregate, classify or otherwise discriminate against a person on the basis of sex with respect to a term, condition or privilege of employment, including a benefit plan or system.

* Except for contracts entered into with parties employing less than three employees.

APPENDIX C



**THE CITY OF KALAMAZOO
DEPARTMENT OF PUBLIC SERVICES
ENGINEERING DIVISION**

PLANS/DRAWINGS

**ACADEMY STREET SIDEWALK
IMPROVEMENT**

Bid Reference #: 91347.008.0

ACADEMY ST SIDEWALK REPAIRS/REPLACEMENT AREAS

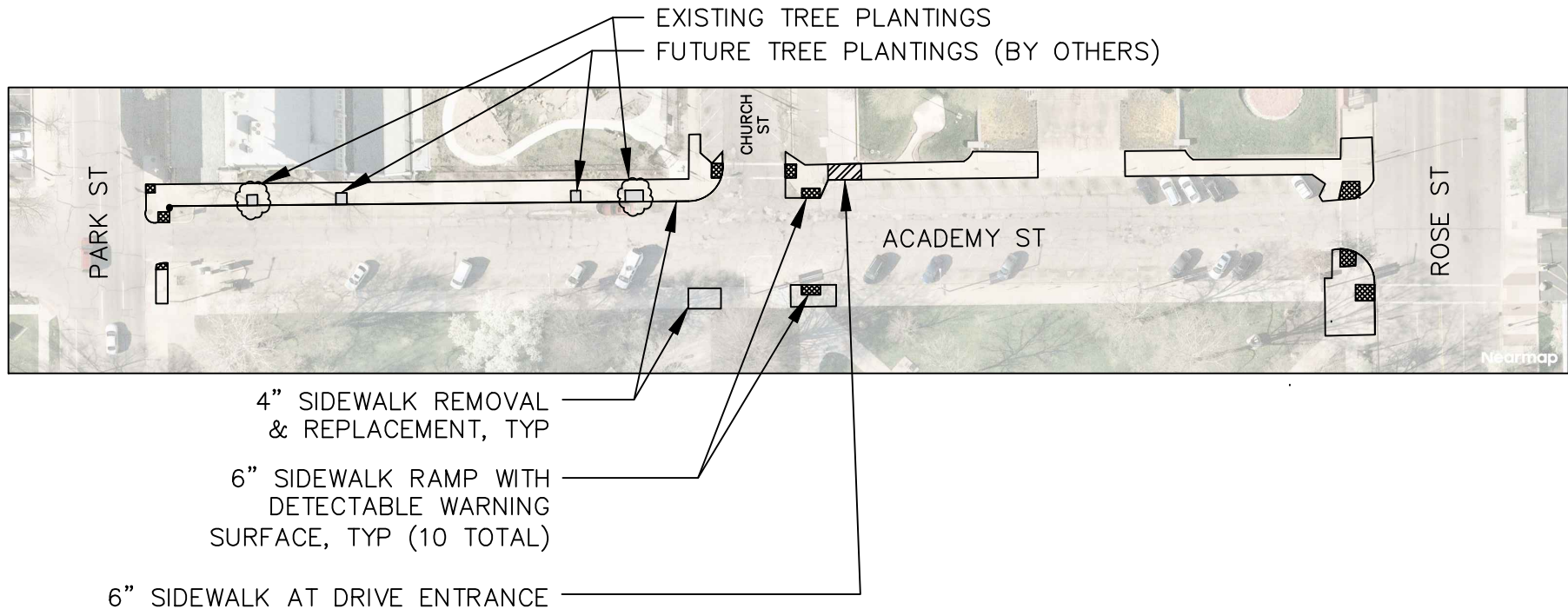

QUANTITIES:

MOBILIZATION, MAX \$8,000	1 EA
SIDEWALK, REM	875 SYD
CURB & GUTTER, REM, SPECIAL GEOTEXTILE SEPARATOR	110 FT
CURB & GUTTER, CONC, DET C4	30 SYD
SIDEWALK, CONC, 4 INCH	110 FT
SIDEWALK, CONC, 6 INCH	7,400 SFT
SIDEWALK RAMP, CONC, 6 INCH	150 SFT
DETECTABLE WARNING SURFACE, MODIFIED	200 SFT
MAINTENANCE OF TRAFFIC	40 FT
	1 LSUM

CITY OF KALAMAZOO
PUBLIC WORKS DIVISION
ACADEMY STREET SIDEWALK IMPROVEMENT

Drafted: MRK
Checked: TAP
Date: 8/13/2025

STANDARD DETAIL – SIDEWALK
ROOT AVOIDANCE – MEANDERING SIDEWALK

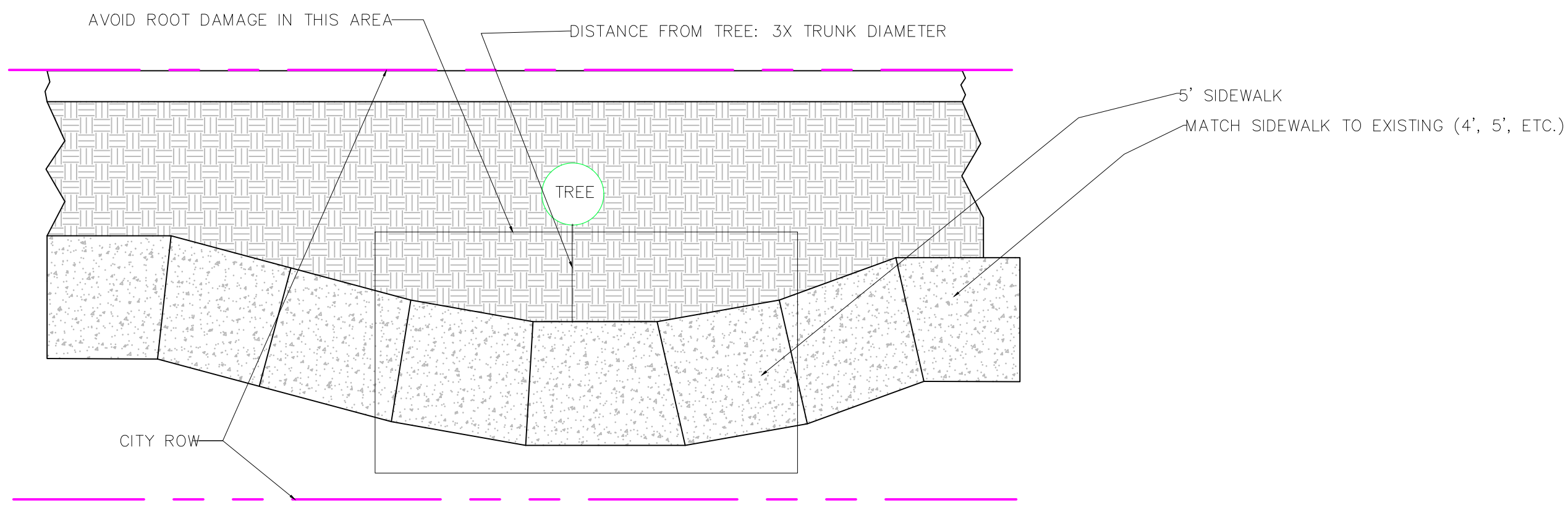

STANDARD DETAIL – SIDEWALK
ROOT AVOIDANCE

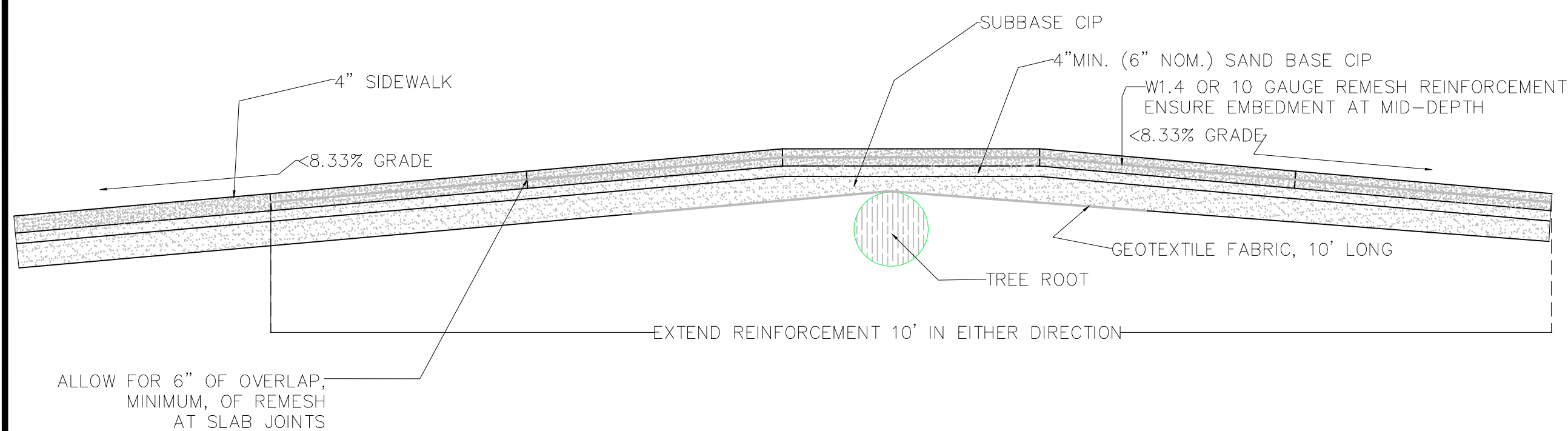

STANDARD DETAIL – SIDEWALK
ROOT AVOIDANCE – W/O REINFORCEMENT
(USE ONLY AS DIRECTED BY ENGINEER)

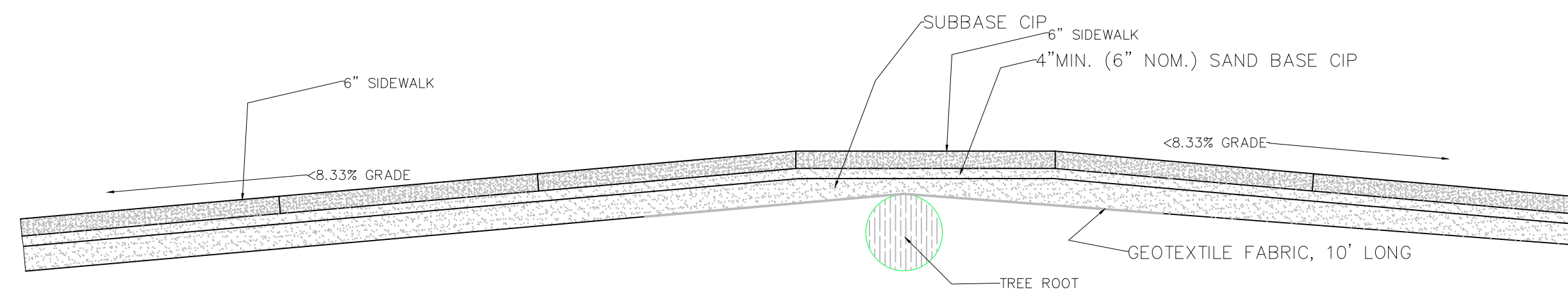

TYPICAL 4" SIDEWALK DETAIL

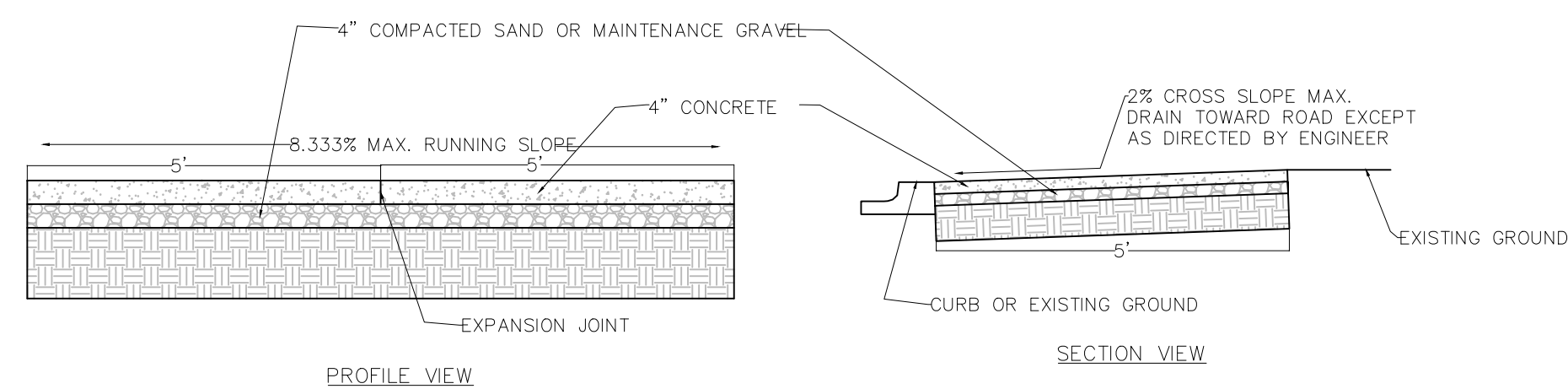

ROOT CRACKING OF SIDEWALK

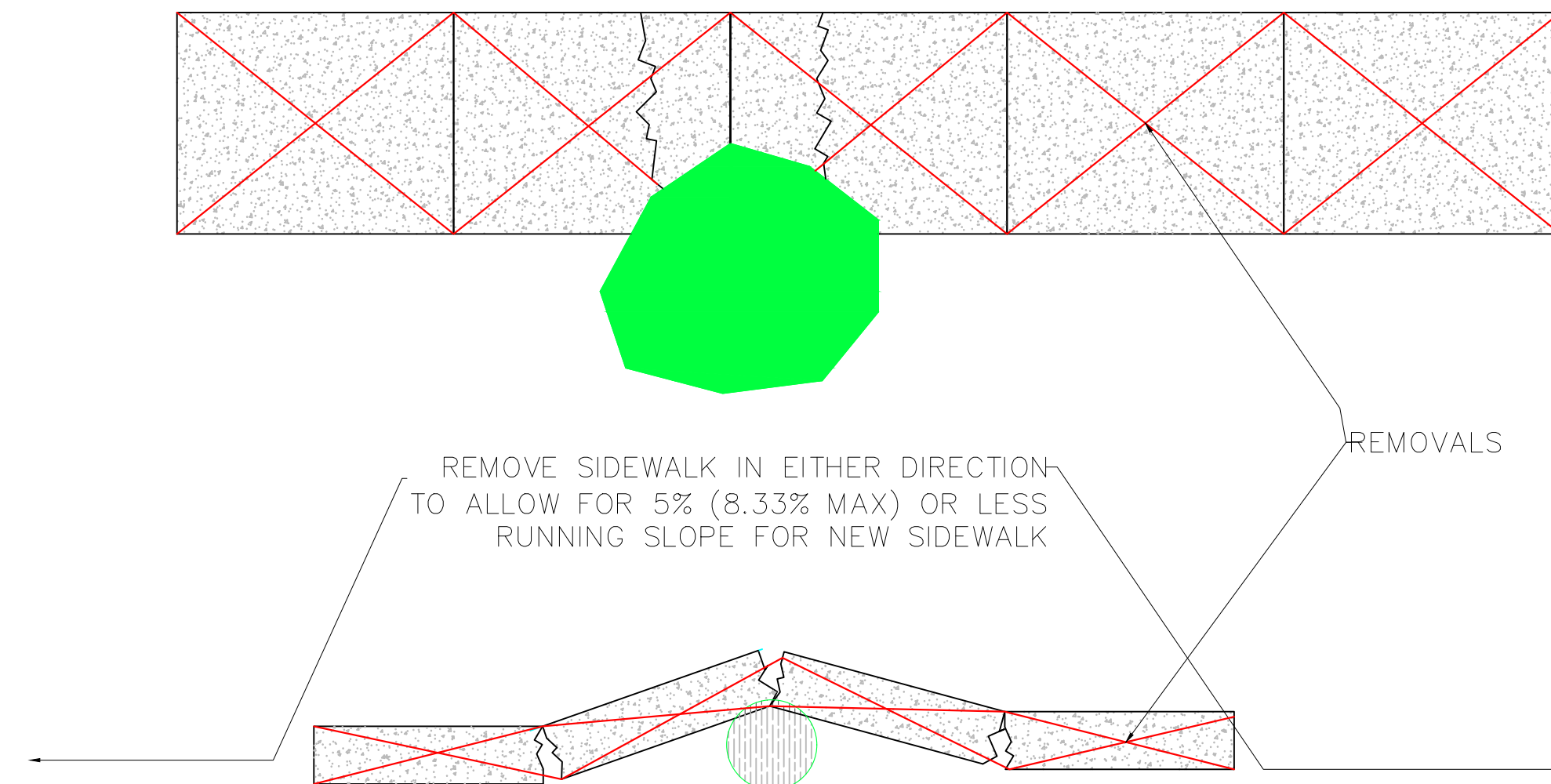

STANDARD DETAIL – WEDGING
A CUT/MILLED SECTION

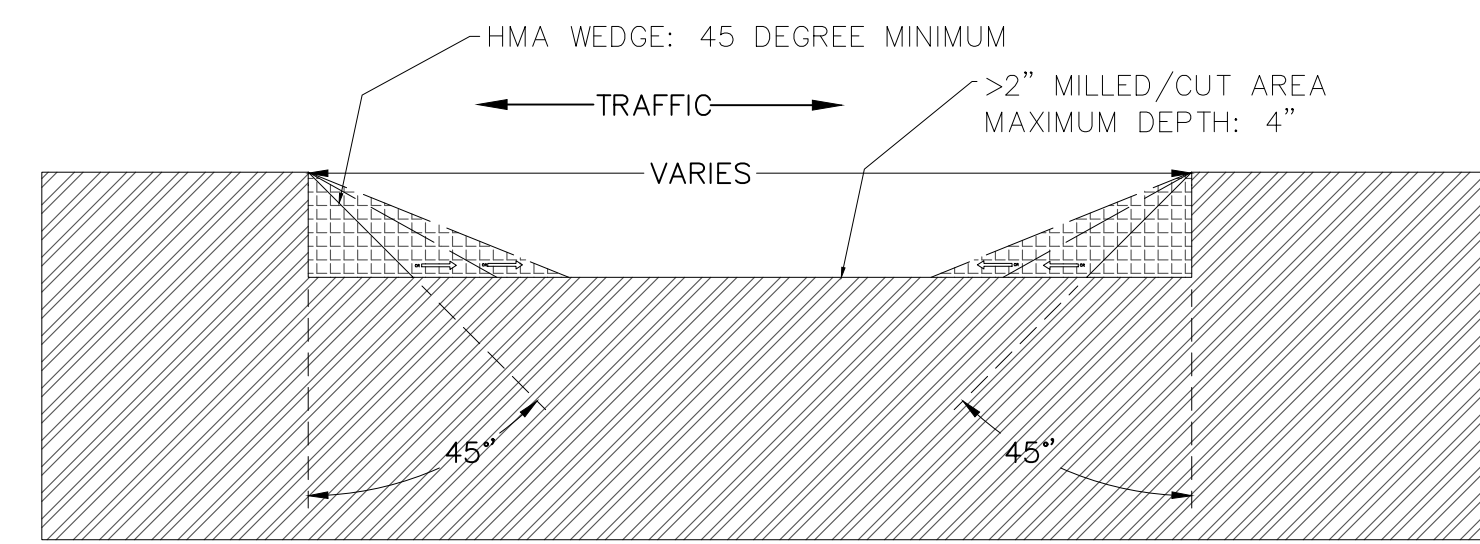

STANDARD DETAIL – LOW VOLUME/RESIDENTIAL ROADS
PERFORATED PIPE DETAIL

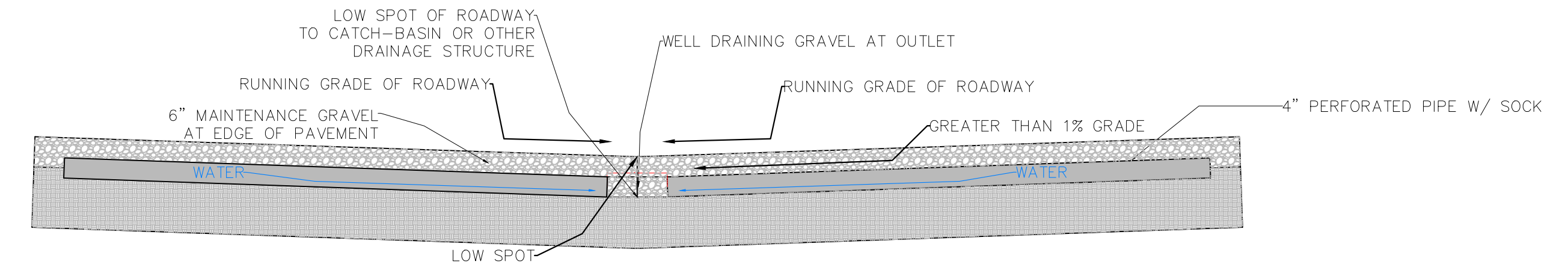

STANDARD DETAIL – LOW VOLUME/RESIDENTIAL ROADS
POORLY DRAINED AREAS

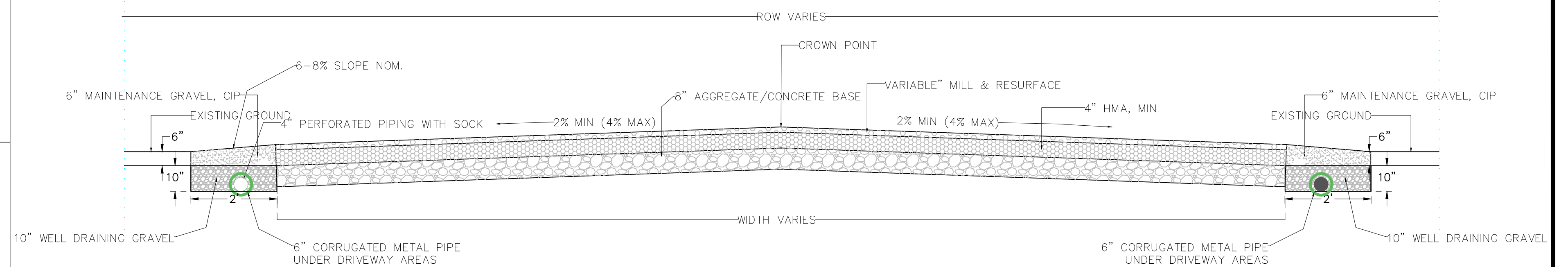

STANDARD DETAIL – LOW VOLUME/RESIDENTIAL ROADS
EASILY DRAINED AREAS

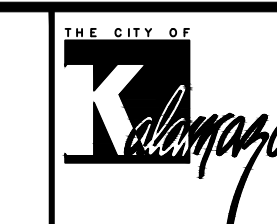
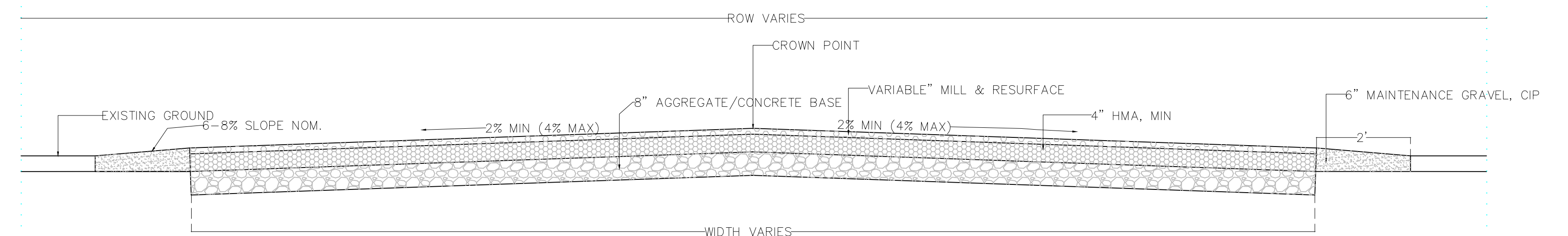

SURVEYED	N/A	SCALE	REVISIONS
DESIGNED	GHW	VERTICAL NOT TO SCALE	1, 12.18.20 - Agg base depth & option of 2C base
DRAWN	GHW	HORIZONTAL NOT TO SCALE	1, 12.17.21 - General updates plus MDOT HMA updates
QA/QC	AL	DATE	11/23/2020
ENG PROJ #	XXX-XX		

GENERAL NOTES:

- MDOT STANDARD PLANS R-28-J, R-29-I, R-30-G, AND R-44-F SHALL BE FOLLOWED IN CONJUNCTION WITH THESE STANDARD PLANS
- ALL SAW CUTTING SHALL BE DONE PERPENDICULAR AND PARALLEL TO THE DIRECTION OF TRAVEL
- SAW CUTTING SHALL PROVIDE A STRAIGHT, CLEAN, EDGE TO ENHANCE BONDING
- ALL CUTS SHALL BE RECTANGULAR AND NEATLY CUT TO AVOID SPALLING OF PAVEMENT
- IN GENERAL ALL ROAD/UTILITY CUTS OF AN AREA GREATER THAN 25SFT (5FTX5FT TYPICAL) SHALL EXTEND THE FULL WIDTH OF THE TRAVEL LANE
- FOR PAVEMENT WITH LOAD TRANSFER DOWEL RODS OR REINFORCEMENT: NEW LOAD TRANSFER DOWELS/REINFORCEMENT SHALL BE PLACED TO MAINTAIN BEARING CAPACITY OF ROADWAY
- CUTS LESS THAN 12" SHALL BE PATCHED WITH PCC. IF GREATER THAN 12", ENSURE CUT IS IN ACCORDANCE WITH STANDARD DETAILS AND MATCHING EXISTING ROADWAY
- BUMPS/CUTS/MILLED AREAS WITH EDGE GREATER THAN 2" DEEP/HIGH MUST BE WEDGED WITH HMA BEFORE OPEN TO TRAFFIC. SEE STANDARD DETAIL.
- MEANDERING SIDEWALK SHALL ONLY BE PLACED IN THE CITY'S ROW OR WHERE AN EASEMENT IS ESTABLISHED
- NEW SIDEWALK CONSTRUCTION SHALL MEET OR EXCEED CURRENT ADA AND ACCESSIBILITY STANDARDS
- REPLACED SIDEWALK SHALL, TO THE EXTENT PRACTICABLE, MEET OR EXCEED ADA AND ACCESSIBILITY STANDARDS
- SIDEWALK, DRIVEWAY OPENINGS & APPROACHES SHALL CONFORM TO MDOT STANDARD PLAN DETAILS R-28-J AND R-29-I
- MARSHALL MIX 13A (BASE/LEVELING) MAY BE SUBSTITUTED FOR SUPERPAVE HMA BASE MIX DESIGNS WITH CITY OF KALAMAZOO APPROVAL IF DEEMED APPROPRIATE BY THE ENGINEER
- ASPHALT BINDER SHALL BE INCLUDED IN THE PAY ITEM FOR HMA
- MDOT PCC P1 MIX DESIGN SHALL BE USED FOR ALL CONCRETE UNLESS OTHERWISE STATED OR DIRECTED BY THE ENGINEER
- OPENING TO TRAFFIC STRENGTHS (2012 STANDARD SPECIFICATIONS FOR CONSTRUCTION, TABLE 603-1):
 - <72 HOURS, GRADE P-NC, 300 psi
 - 72 HOURS +, GRADE P1, P1M, 550 psi



STANDARD DETAILS

CITY OF KALAMAZOO

SURVEYED		SCALE		REVISIONS	
DESIGNED	N/A	VERTICAL	NOT TO SCALE	1. 12.18.20	Agg base depth & option of 2C base
DRAWN	GHW	HORIZONTAL	NOT TO SCALE	2. 12.17.21	General updates plus MDOT HMA updates
QA/QC	AL	DATE	11/23/2020		
ENG PROJ #	XXX-XX				

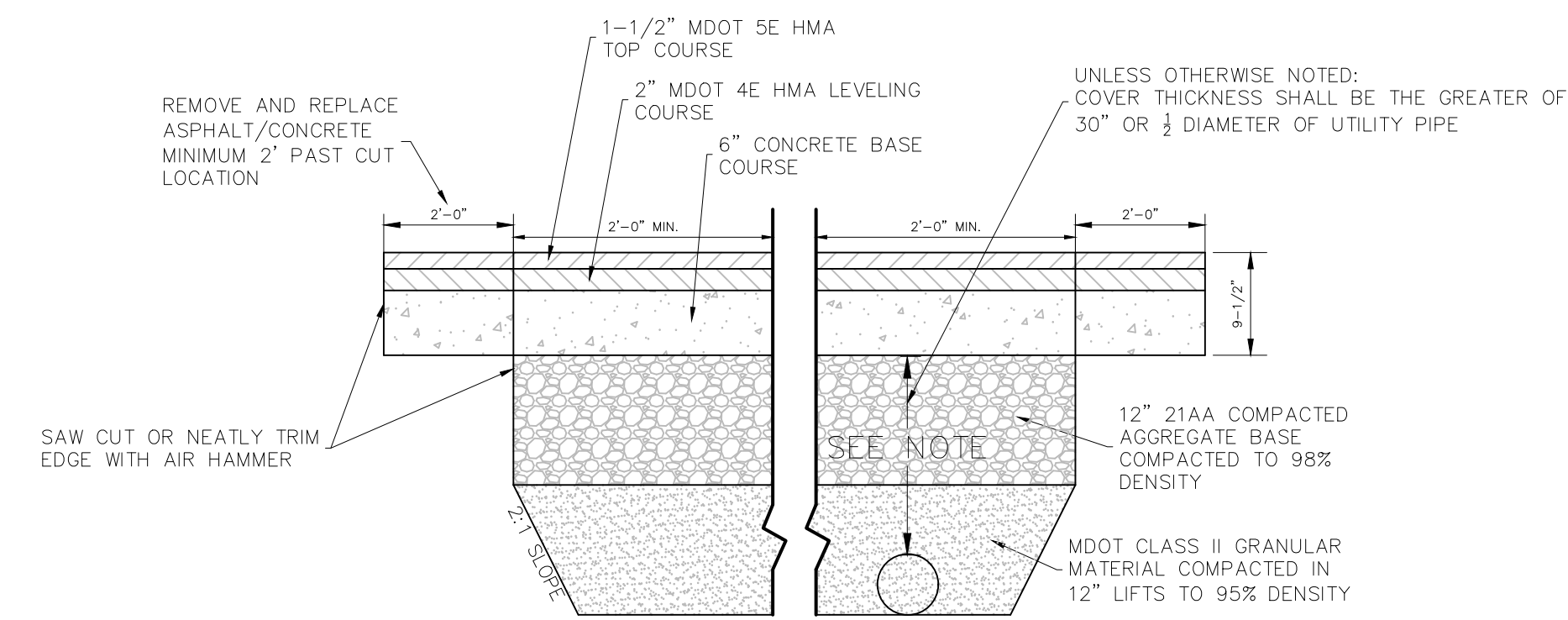

ASPHALT WITH CONCRETE BASE TRENCH DETAIL

- NOTE:
- CUT SHALL BE PARALLEL OR PERPENDICULAR TO EDGE OF ROADWAY/GUTTER
 - FOR POTHoles 12" DIAMETER AND SMALLER - ALL CONCRETE
 - FOR 1' x 1' AND LARGER HAND COMPACT LAYERS AS SHOWN AND FINISH WITH CONCRETE

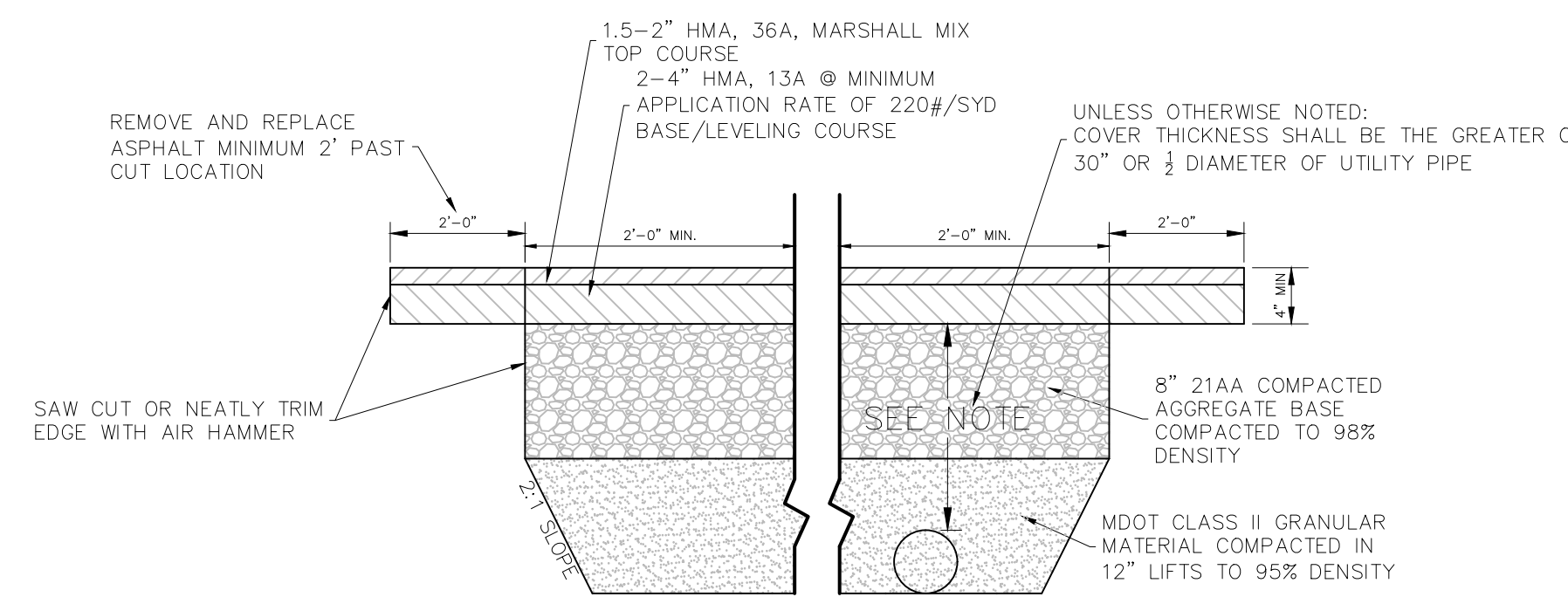

RESIDENTIAL / LOW TRAFFIC VOLUME ROAD ASPHALT UTILITY TRENCH DETAIL

- NOTE:
- CUT SHALL BE PARALLEL OR PERPENDICULAR TO EDGE OF ROADWAY/GUTTER
 - *SS-1H @ 0.10/GAL/SYD BETWEEN LIFTS
 - PERFORMANCE GRADE BINDER TO BE USED: PG 64-28

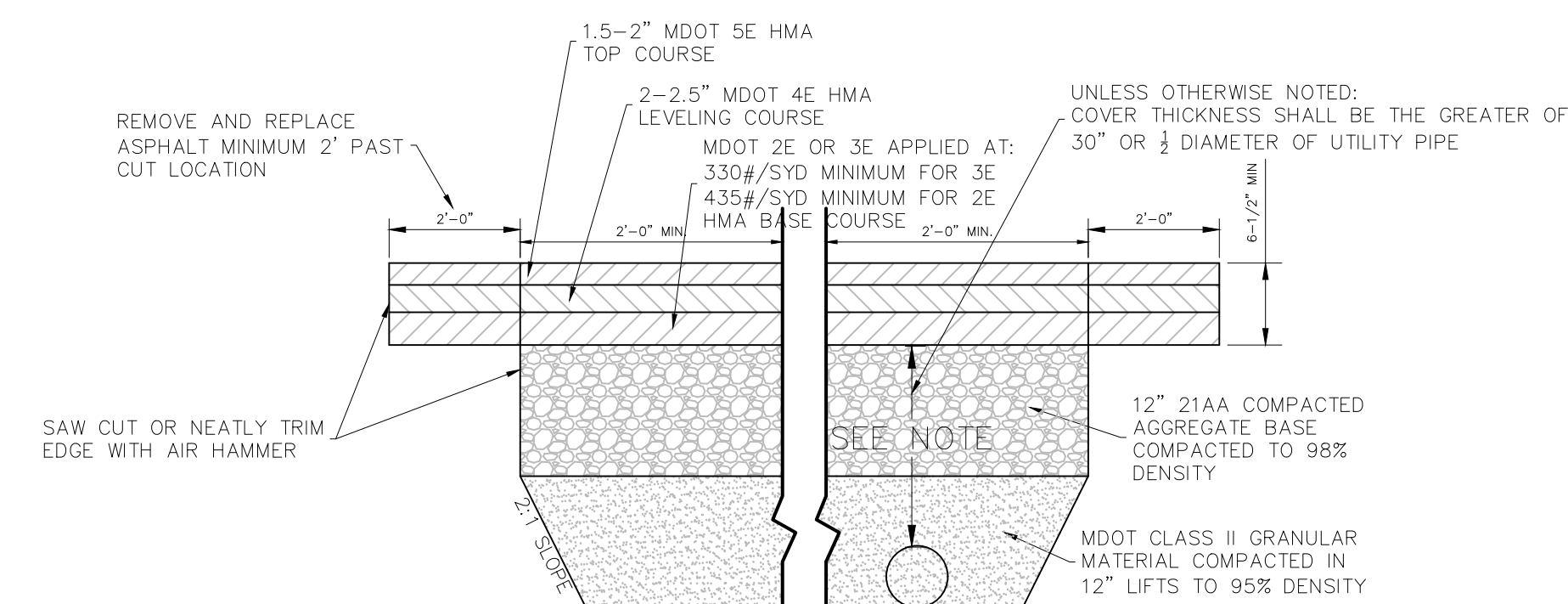

COMMERCIAL ROAD ASPHALT UTILITY TRENCH DETAIL

- NOTE:
- CUT SHALL BE PARALLEL OR PERPENDICULAR TO EDGE OF ROADWAY/GUTTER
 - *SS-1H @ 0.10/GAL/SYD BETWEEN LIFTS
 - PERFORMANCE GRADE BINDER TO BE USED: PG 64-28
 - HEAVY COMMERCIAL ADT COULD WARRANT CHANGE TO DESIGN.

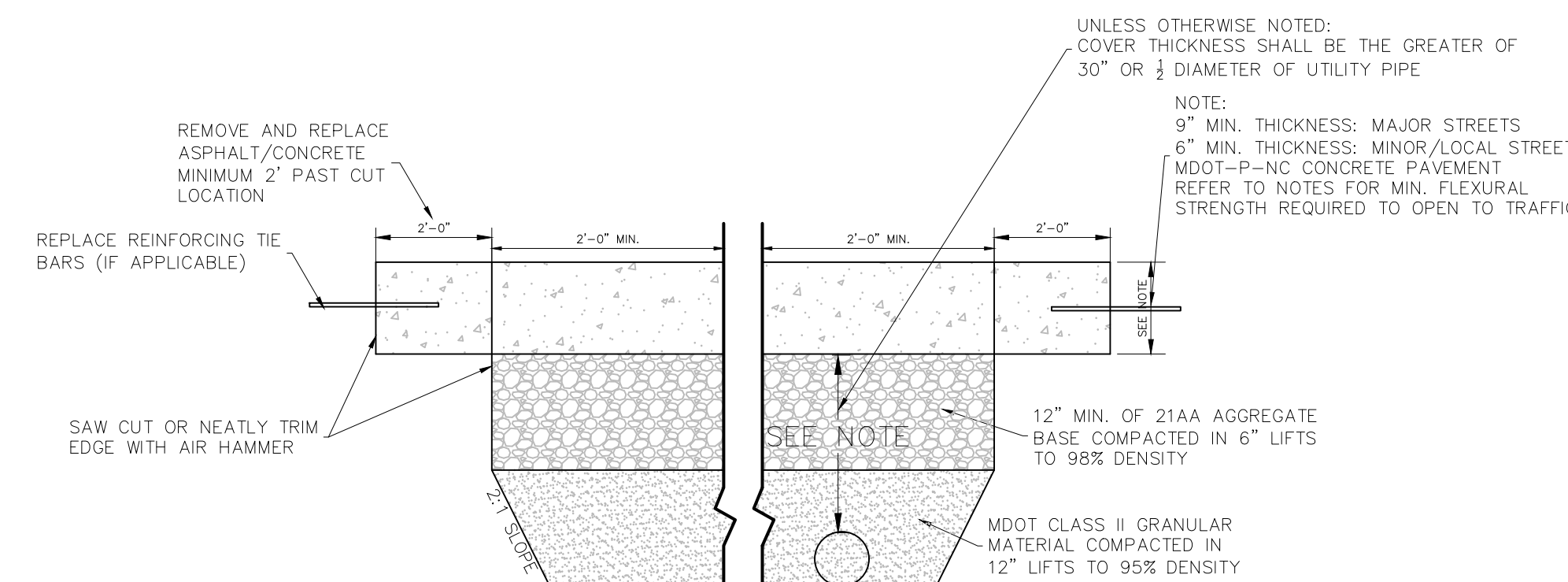

TYPICAL CUT USING PCC TO FILL (WINTER CUT)

- NOTE:
- CUT SHALL BE PARALLEL OR PERPENDICULAR TO EDGE OF ROADWAY/GUTTER
 - FOR POTHoles 12" DIAMETER AND SMALLER - ALL CONCRETE
 - FOR 1' x 1' AND LARGER HAND COMPACT LAYERS AS SHOWN AND FINISH WITH CONCRETE

GENERAL NOTES:

- MDOT STANDARD PLANS R-28-J, R-29-I, R-30-G, AND R-44-F SHALL BE FOLLOWED IN CONJUNCTION WITH THESE STANDARD PLANS
- ALL SAW CUTTING SHALL BE DONE PERPENDICULAR AND PARALLEL TO THE DIRECTION OF TRAVEL
- SAW CUTTING SHALL PROVIDE A STRAIGHT, CLEAN, EDGE TO ENHANCE BONDING
- ALL CUTS SHALL BE RECTANGULAR AND NEATLY CUT TO AVOID SPALLING OF PAVEMENT
- IN GENERAL ALL ROAD/UTILITY CUTS OF AN AREA GREATER THAN 25SFT (5FTX5FT TYPICAL) SHALL EXTEND THE FULL WIDTH OF THE TRAVEL LANE
- FOR PAVEMENT WITH LOAD TRANSFER DOWEL RODS OR REINFORCEMENT: NEW LOAD TRANSFER DOWELS/REINFORCEMENT SHALL BE PLACED TO MAINTAIN BEARING CAPACITY OF ROADWAY
- CUTS LESS THAN 12" SHALL BE PATCHED WITH PCC. IF GREATER THAN 12", ENSURE CUT IS IN ACCORDANCE WITH STANDARD DETAILS AND MATCHING EXISTING ROADWAY
- BUMPS/CUTS/MILLED AREAS WITH EDGE GREATER THAN 2" DEEP/HIGH MUST BE WEDGED WITH HMA BEFORE OPEN TO TRAFFIC. SEE STANDARD DETAIL.
- MEANDERING SIDEWALK SHALL ONLY BE PLACED IN THE CITY'S ROW OR WHERE AN EASEMENT IS ESTABLISHED
- NEW SIDEWALK CONSTRUCTION SHALL MEET OR EXCEED CURRENT ADA AND ACCESSIBILITY STANDARDS
- REPLACED SIDEWALK SHALL, TO THE EXTENT PRACTICABLE, MEET OR EXCEED ADA AND ACCESSIBILITY STANDARDS
- SIDEWALK, DRIVEWAY OPENINGS & APPROACHES SHALL CONFORM TO MDOT STANDARD PLAN DETAILS R-28-J AND R-29-I
- MARSHALL MIX 13A (BASE/LEVELING) MAY BE SUBSTITUTED FOR SUPERPAVE HMA BASE MIX DESIGNS WITH CITY OF KALAMAZOO APPROVAL IF DEEMED APPROPRIATE BY THE ENGINEER
- ASPHALT BINDER SHALL BE INCLUDED IN THE PAY ITEM FOR HMA
- MDOT PCC P1 MIX DESIGN SHALL BE USED FOR ALL CONCRETE UNLESS OTHERWISE STATED OR DIRECTED BY THE ENGINEER
- OPENING TO TRAFFIC STRENGTHS (2012 STANDARD SPECIFICATIONS FOR CONSTRUCTION, TABLE 603-1):
 - <72 HOURS, GRADE P-NC, 300 psi
 - 72 HOURS +, GRADE P1, P1M, 550 psi

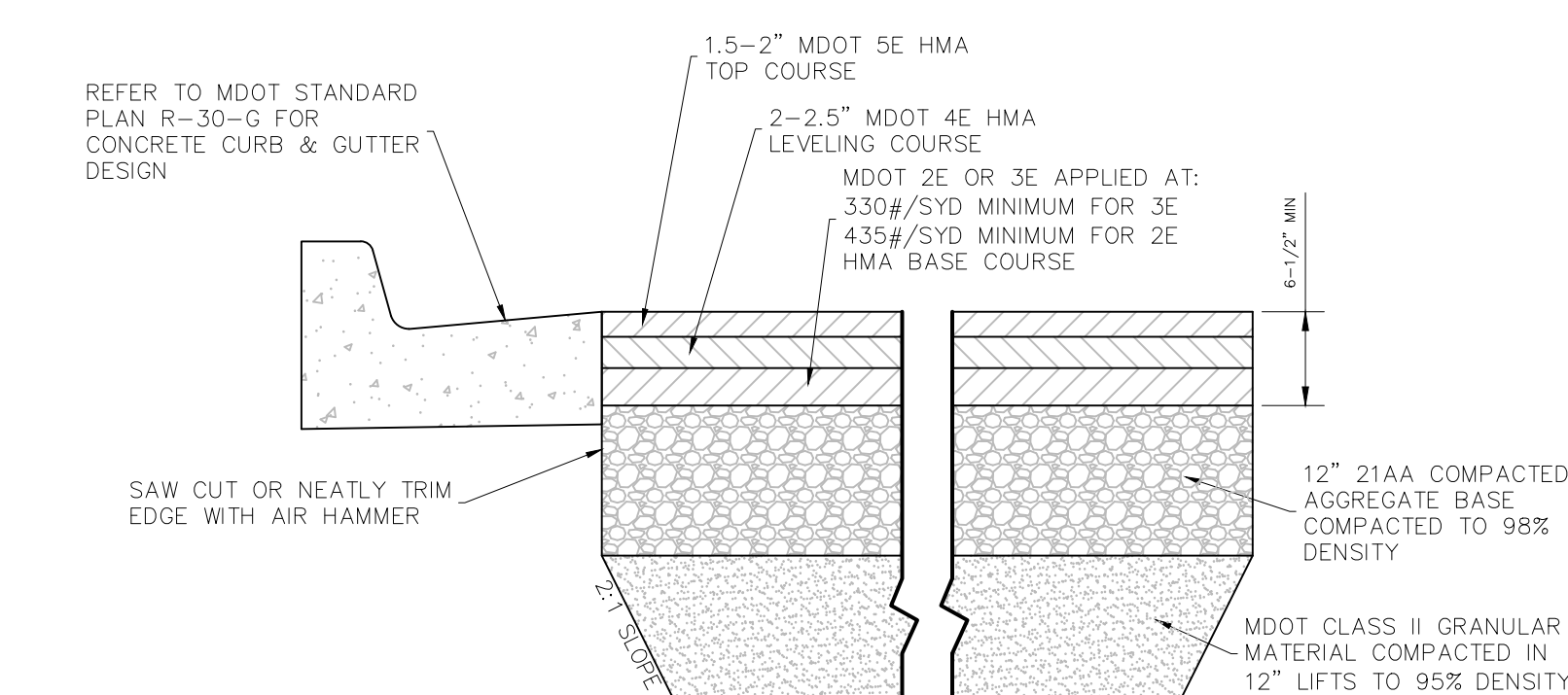

COMMERCIAL ROAD ASPHALT PAVEMENT DETAIL

- NOTE:
- *SS-1H @ 0.10/GAL/SYD BETWEEN LIFTS
 - PERFORMANCE GRADE BINDER TO BE USED: PG 64-28

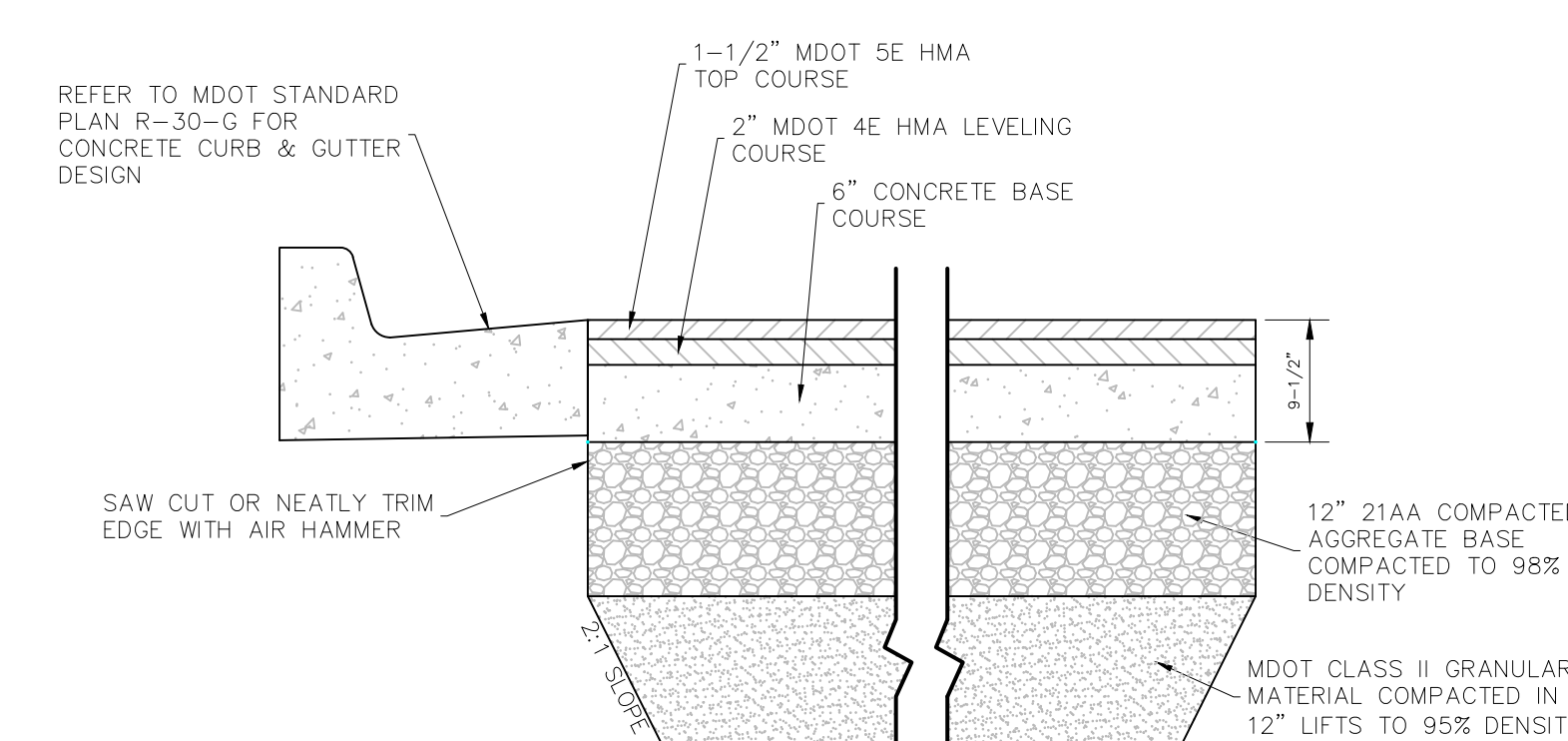

ASPHALT PAVEMENT WITH CONCRETE BASE DETAIL

- NOTE:
- *SS-1H @ 0.10/GAL/SYD BETWEEN LIFTS
 - PERFORMANCE GRADE BINDER TO BE USED: PG 64-28

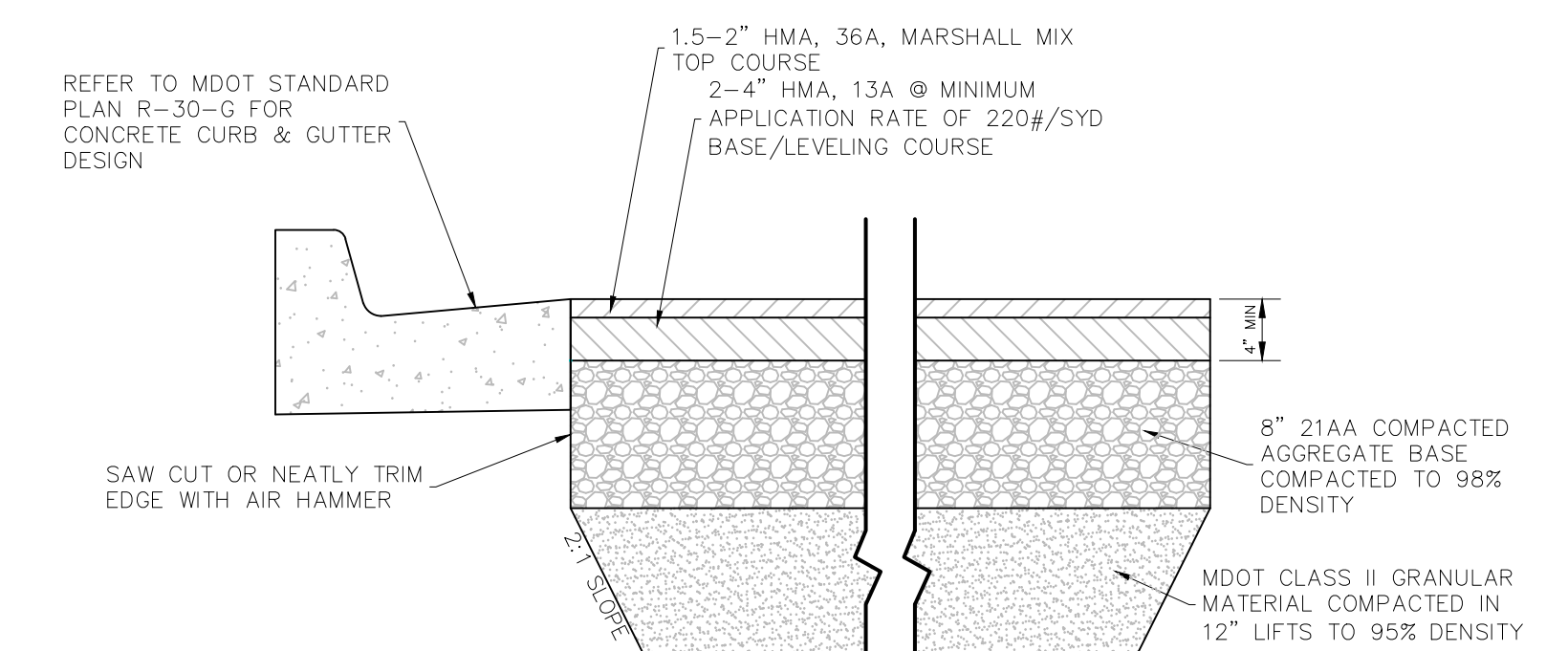

RESIDENTIAL / LOW TRAFFIC VOLUME ROAD ASPHALT PAVEMENT DETAIL

- NOTE:
- *SS-1H @ 0.10/GAL/SYD BETWEEN LIFTS
 - PERFORMANCE GRADE BINDER TO BE USED: PG 64-28

* MAXIMUM LANDING SLOPE IS 2.0% IN EACH DIRECTION OF TRAVEL. LANDING MINIMUM DIMENSIONS 5' x 5'. SEE NOTES.

** MAXIMUM RAMP CROSS SLOPE IS 2.0%, RUNNING SLOPE 5% - 7% (8.3% MAXIMUM). SEE NOTES.

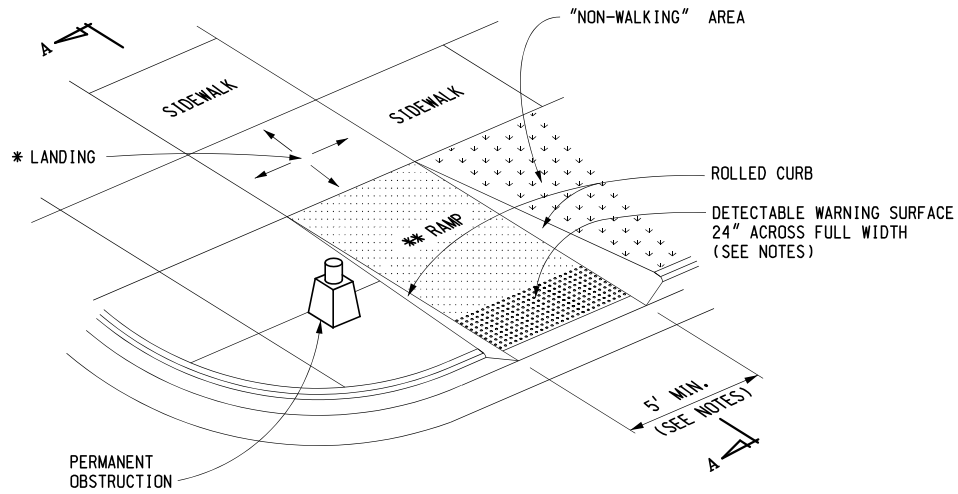

CURB RAMP TYPE R
(ROLLED SIDES)

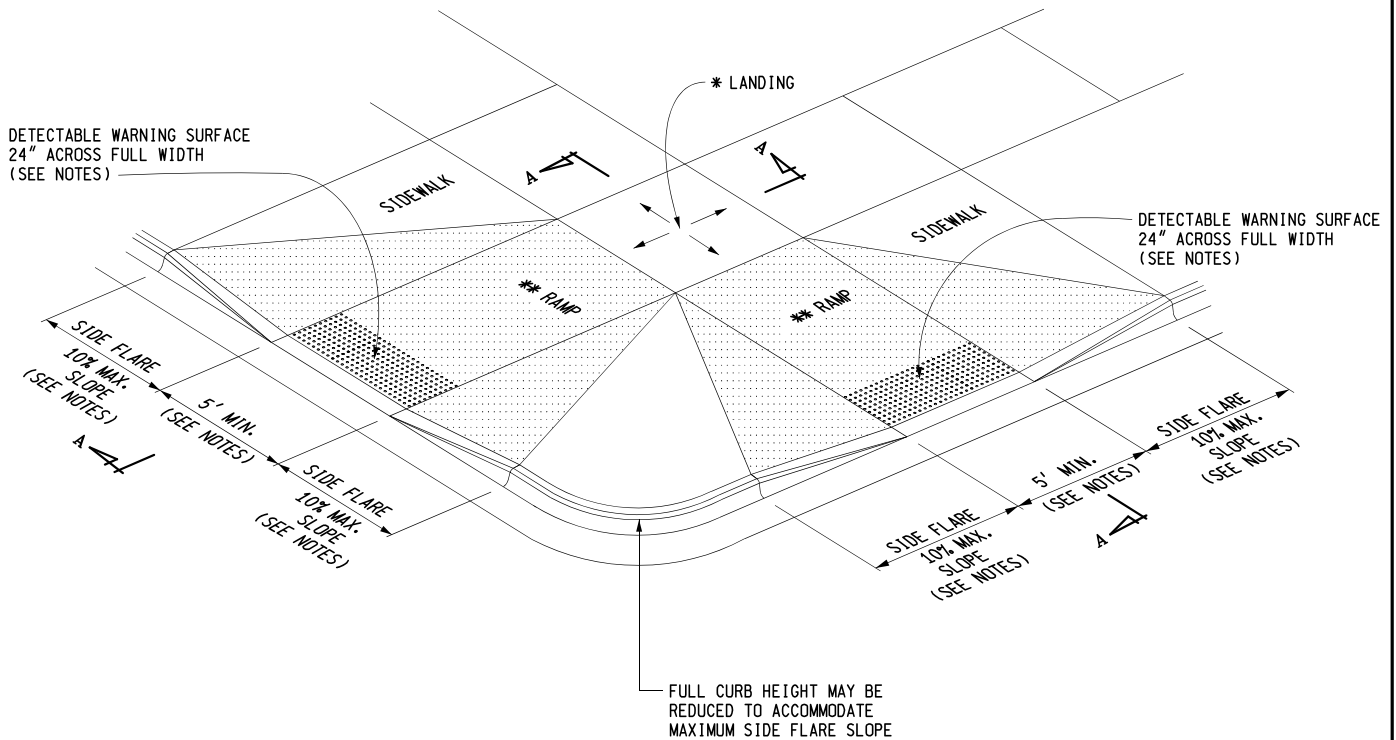

CURB RAMP TYPE F
(FLARED SIDES, TWO RAMPS SHOWN)



PREPARED BY
DESIGN DIVISION

DRAWN BY: B.L.T.

CHECKED BY: W.K.P.

DEPARTMENT DIRECTOR
Paul C. Ajegba

APPROVED BY: Gregg Brunner, P.E. Gregg Brunner
Oct 14 2021 12:32 PM
DIRECTOR, BUREAU OF FIELD SERVICES

APPROVED BY: Bradley C. Wiefelrich Bradley C. Wiefelrich
Oct 14 2021 11:01 AM
DIRECTOR, BUREAU OF DEVELOPMENT

MICHIGAN DEPARTMENT OF TRANSPORTATION
BUREAU OF DEVELOPMENT STANDARD PLAN FOR

**CURB RAMP AND
DETECTABLE WARNING DETAILS**

4-7-2022
F.H.W.A. APPROVAL

5-8-2020
PLAN DATE

R-28-J

SHEET
1 OF 7

* MAXIMUM LANDING SLOPE IS 2.0% IN EACH DIRECTION OF TRAVEL. LANDING MINIMUM DIMENSIONS 5' x 5'. SEE NOTES.

** MAXIMUM RAMP CROSS SLOPE IS 2.0%, RUNNING SLOPE 5% - 7% (8.3% MAXIMUM). SEE NOTES.

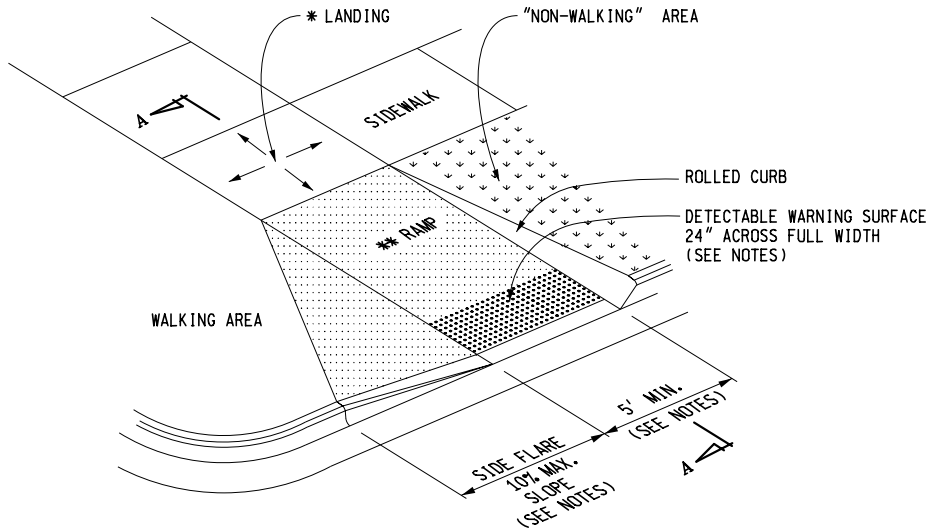

CURB RAMP TYPE RF
(ROLLED / FLARED SIDES)

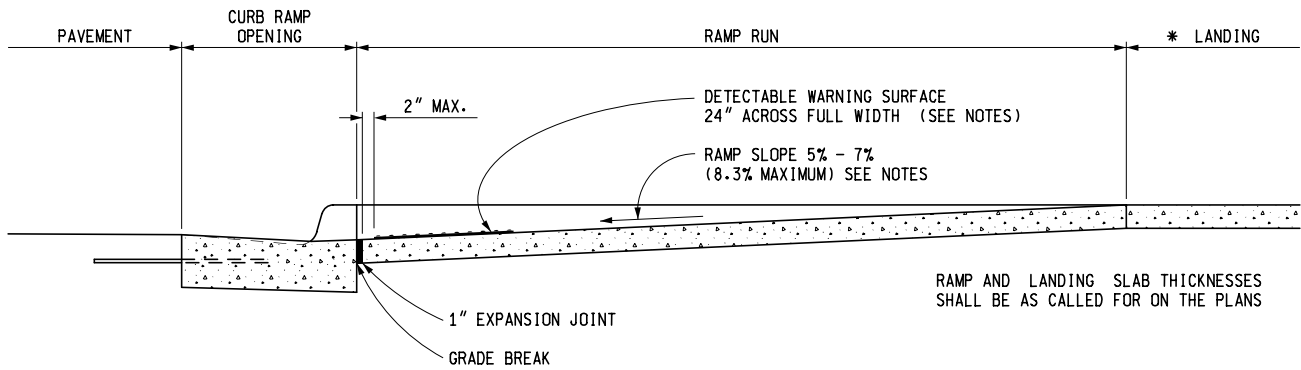

SECTION A-A

CURB TYPE	MAXIMUM RISE (INCHES)	
	A	B
B1	3/4	1
B2	3/4	1
B3	3/4	1
D1	3/4	1
D2	3/4	1
D3	3/4	1
C1	1/2	1/2
C2	1/2	1/2
C3	3/4	1/2
C4	3/4	1/2
C5	1	1/2
C6	1	1/2
F1	1/2	1/2
F2	1/2	1/2
F3	3/4	1/2
F4	3/4	1/2
F5	1	1/2
F6	1	1/2

FOR CURB TYPES SEE STANDARD PLAN R-30-SERIES

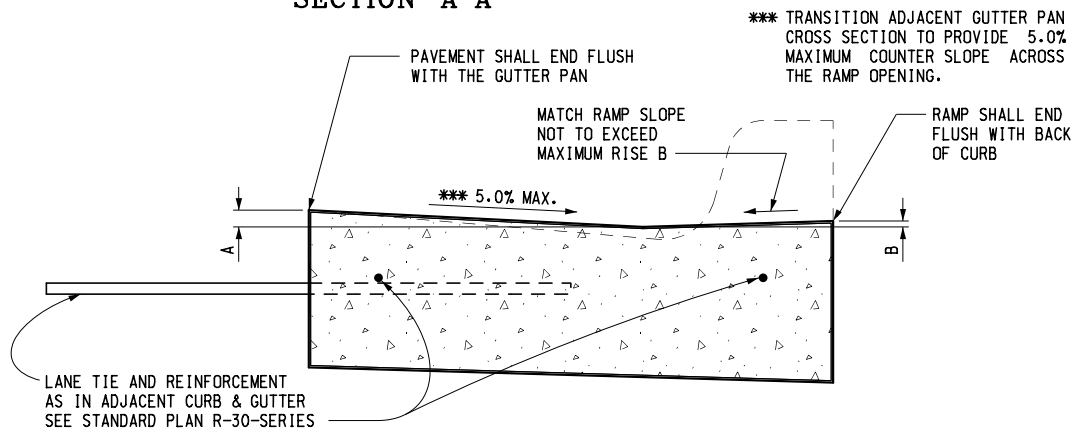

SECTION THROUGH CURB RAMP OPENING
(TYPICAL ALL RAMP TYPES)

MICHIGAN DEPARTMENT OF TRANSPORTATION
BUREAU OF DEVELOPMENT STANDARD PLAN FOR
**CURB RAMP AND
DETECTABLE WARNING DETAILS**

* MAXIMUM LANDING SLOPE IS 2.0% IN EACH DIRECTION OF TRAVEL. LANDING MINIMUM DIMENSIONS 5' x 5'. SEE NOTES.

** MAXIMUM RAMP CROSS SLOPE IS 2.0%, RUNNING SLOPE 5% - 7% (8.3% MAXIMUM). SEE NOTES.

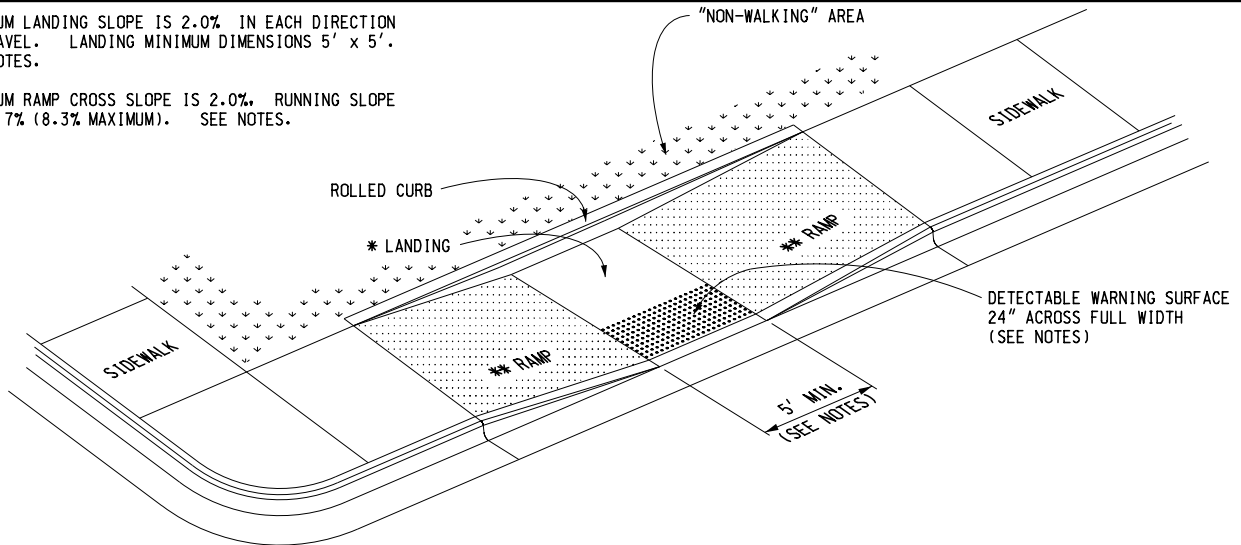

CURB RAMP TYPE P

(PARALLEL RAMP)

DO NOT USE IN AREAS WHERE PONDING MAY OCCUR

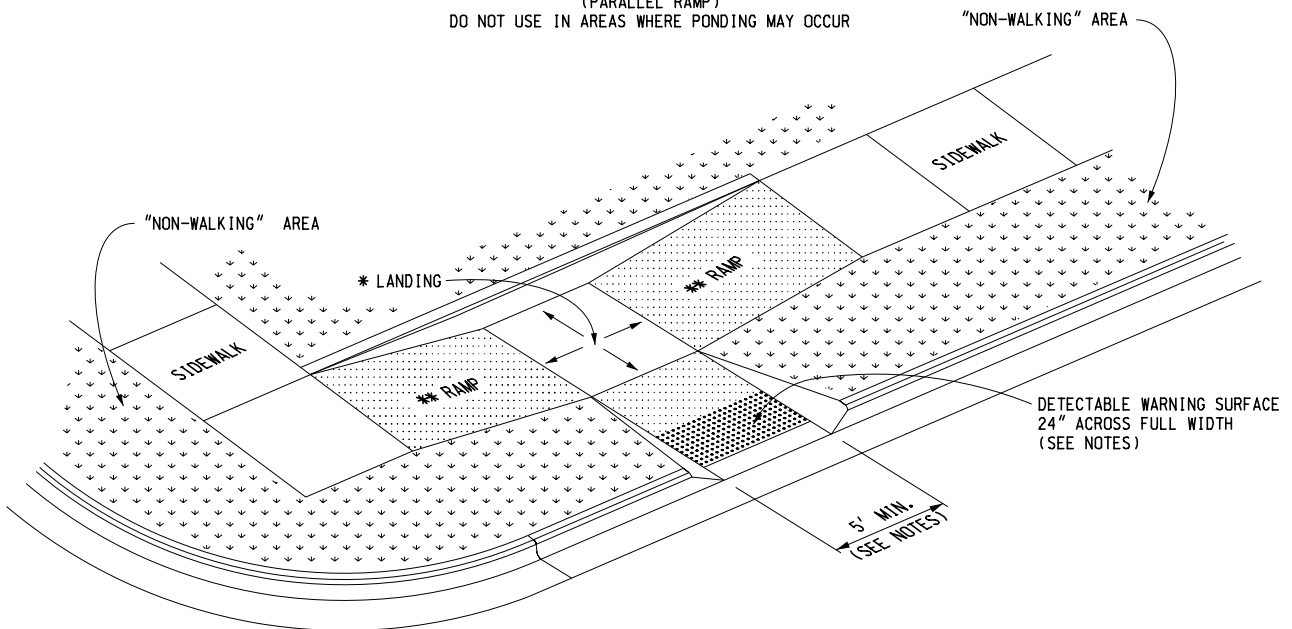

CURB RAMP TYPE C

(COMBINATION RAMP)

DETECTABLE WARNING SURFACE 24" ACROSS FULL WIDTH IF MEDIAN WIDTH IS AT LEAST 6'-0". OTHERWISE NO DETECTABLE WARNING IS REQUIRED.

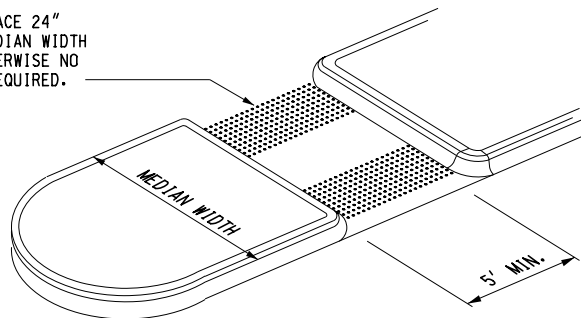

CURB RAMP TYPE M

(MEDIAN ISLAND)

MICHIGAN DEPARTMENT OF TRANSPORTATION
BUREAU OF DEVELOPMENT STANDARD PLAN FOR

**CURB RAMP AND
DETECTABLE WARNING DETAILS**

4-7-2022 F.H.W.A. APPROVAL	5-8-2020 PLAN DATE	R-28-J	SHEET 3 OF 7
-------------------------------	-----------------------	--------	-----------------

* MAXIMUM LANDING SLOPE IS 2.0% IN EACH DIRECTION OF TRAVEL. LANDING MINIMUM DIMENSIONS 5' x 5'. SEE NOTES.

** MAXIMUM RAMP CROSS SLOPE IS 2.0%, RUNNING SLOPE 5% - 7% (8.3% MAXIMUM). SEE NOTES.

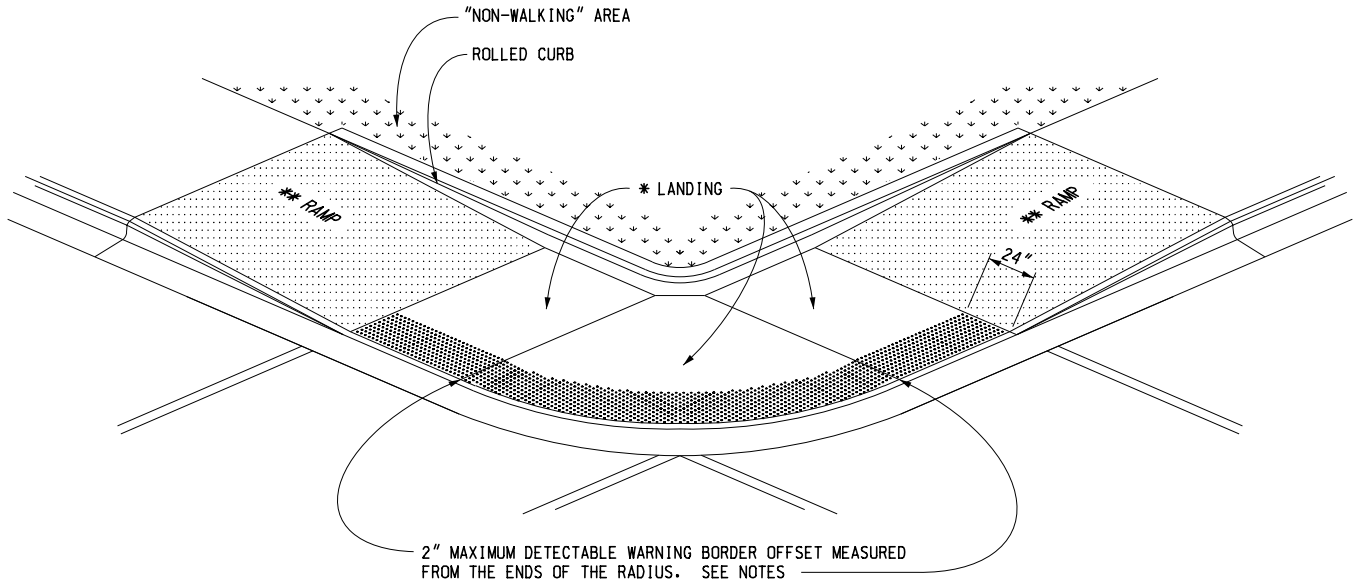

(RADIAL DETECTABLE WARNING SHOWN)

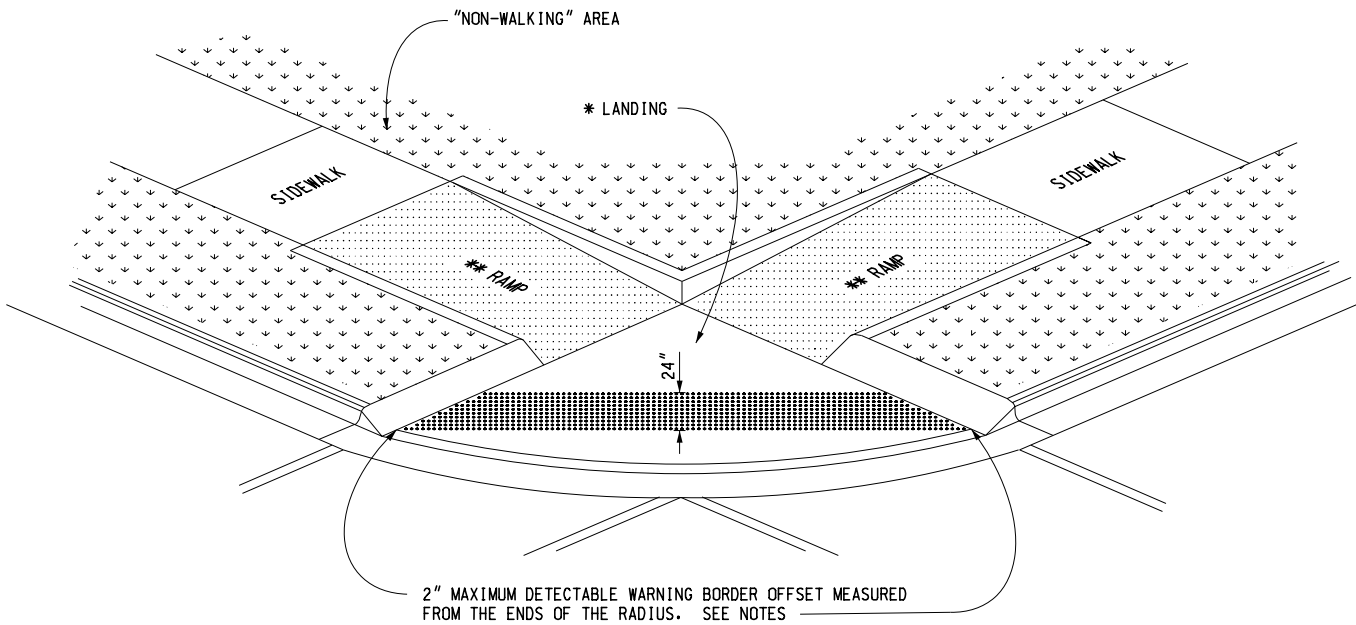

(TANGENT DETECTABLE WARNING SHOWN)

CURB RAMP TYPE D

(DEPRESSED CORNER)

USE ONLY WHEN INDEPENDENT DIRECTIONAL RAMPS CAN NOT BE CONSTRUCTED FOR EACH CROSSING DIRECTION

MICHIGAN DEPARTMENT OF TRANSPORTATION
BUREAU OF DEVELOPMENT STANDARD PLAN FOR

**CURB RAMP AND
DETECTABLE WARNING DETAILS**

4-7-2022 F.H.W.A. APPROVAL	5-8-2020 PLAN DATE	R-28-J	SHEET 4 OF 7
-------------------------------	-----------------------	--------	-----------------

* THE DETECTABLE WARNING SURFACE SHALL BE LOCATED SO THAT THE EDGE NEAREST THE RAIL CROSSING IS 6' MINIMUM AND 15' MAXIMUM FROM THE CENTERLINE OF THE NEAREST RAIL. DO NOT PLACE DETECTABLE WARNING ON RAILROAD CROSSING MATERIAL.

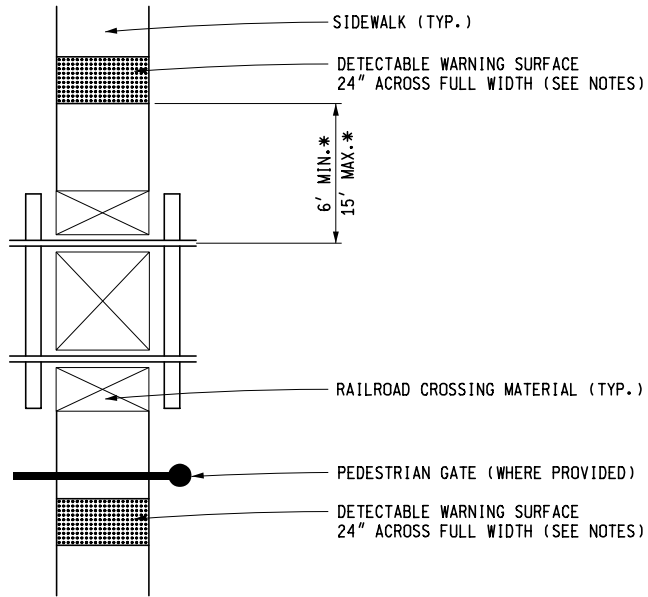

DETECTABLE WARNING AT RAILROAD CROSSING

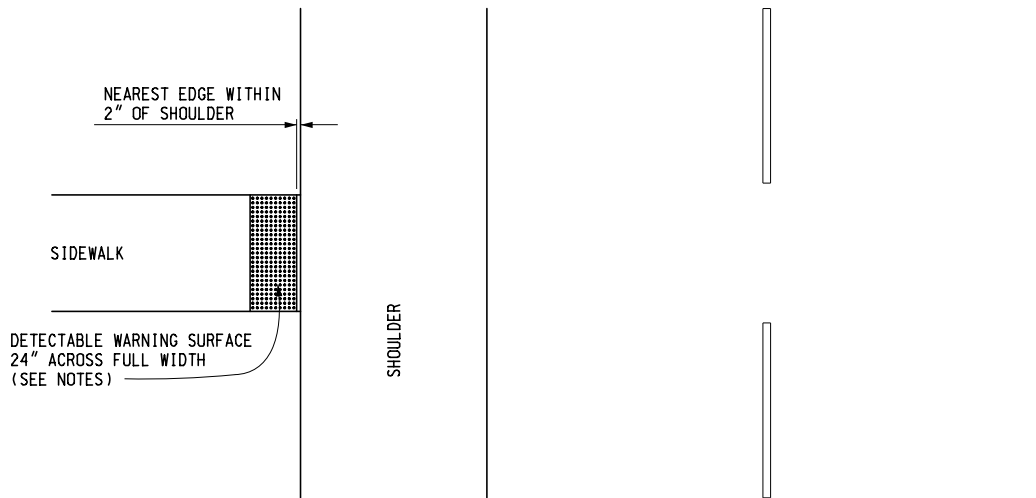



DETECTABLE WARNING AT FLUSH SHOULDER OR ROADWAY

MICHIGAN DEPARTMENT OF TRANSPORTATION
BUREAU OF DEVELOPMENT STANDARD PLAN FOR

**CURB RAMP AND
DETECTABLE WARNING DETAILS**

4-7-2022 F.H.W.A. APPROVAL	5-8-2020 PLAN DATE	R-28-J	SHEET 5 OF 7
-------------------------------	-----------------------	--------	-----------------

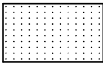
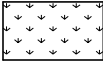
LEGEND

	SLOPED SURFACE
	DETECTABLE WARNING
	"NON-WALKING" AREA
	CROSSWALK MARKING
	PREFERRED LOCATION OF DRAINAGE INLET (TYP.)
	ALTERNATE LOCATION OF DRAINAGE INLET (TYP.)

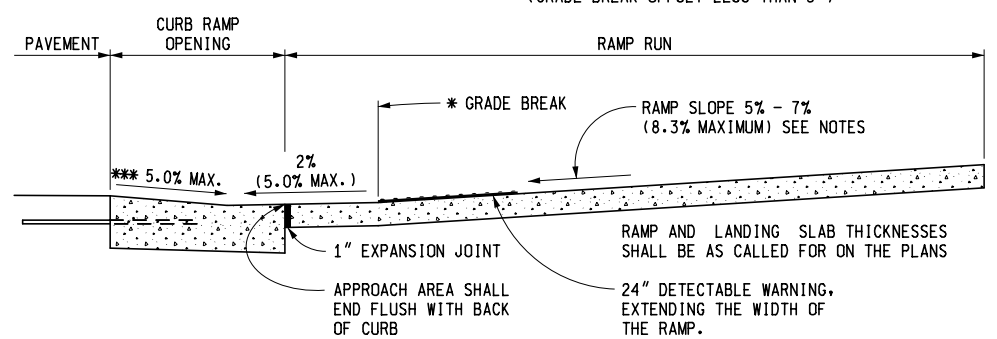
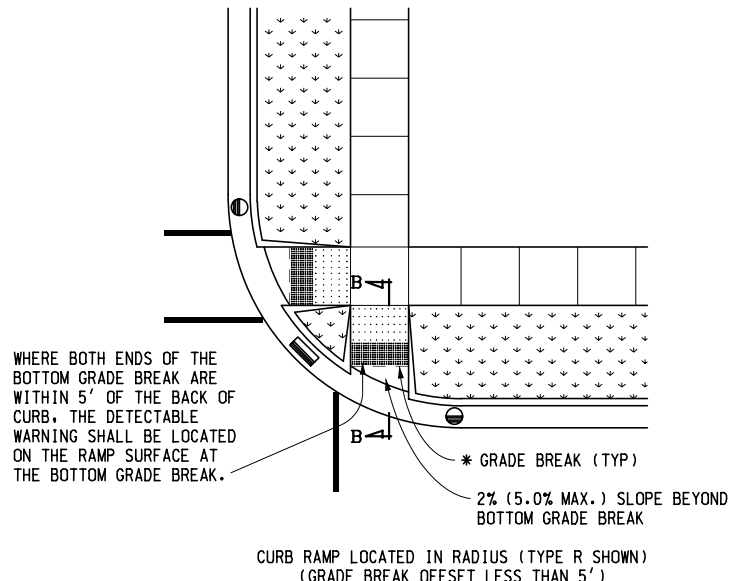
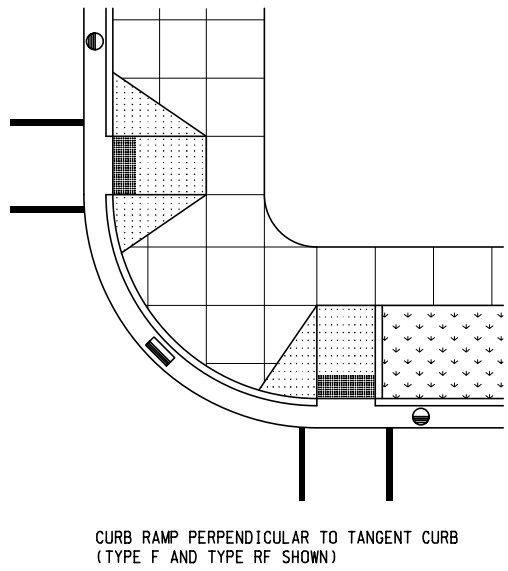
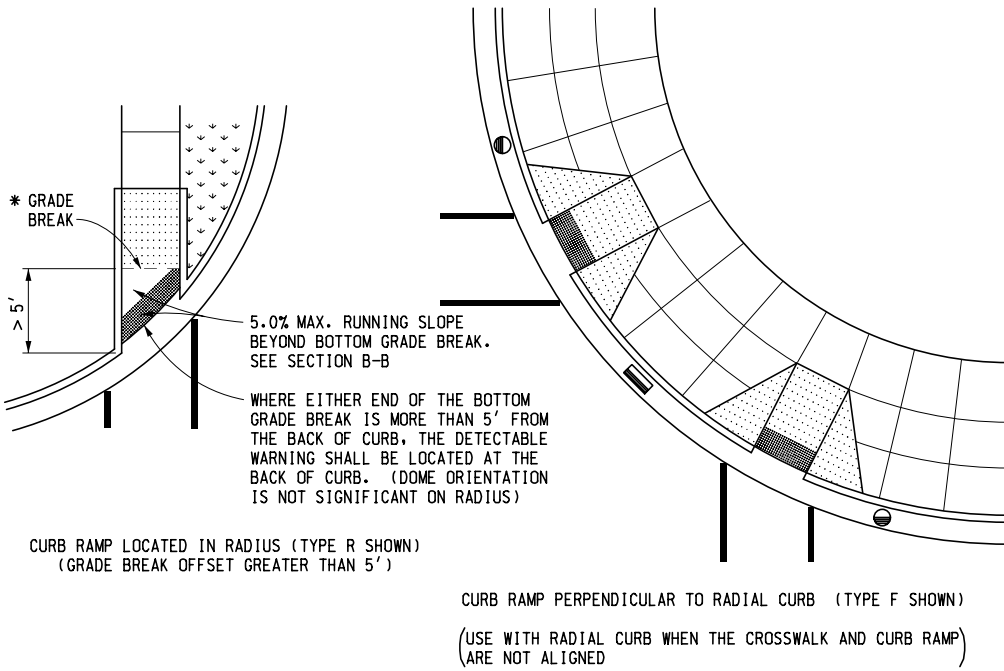

* GRADE BREAKS AT THE TOP AND BOTTOM OF CURB RAMPS SHALL BE PERPENDICULAR TO THE DIRECTION OF TRAVEL.

*** TRANSITION ADJACENT GUTTER PAN CROSS SECTION TO PROVIDE 5.0% MAXIMUM COUNTER SLOPE ACROSS THE RAMP OPENING.

SEE SHEET 2 FOR CURB RAMP OPENING DETAILS.

**SECTION B-B
CURB RAMP ORIENTATION**

MICHIGAN DEPARTMENT OF TRANSPORTATION
BUREAU OF DEVELOPMENT STANDARD PLAN FOR

**CURB RAMP AND
DETECTABLE WARNING DETAILS**

4-7-2022 F.H.W.A. APPROVAL	5-8-2020 PLAN DATE	R-28-J	SHEET 6 OF 7
-------------------------------	-----------------------	--------	-----------------

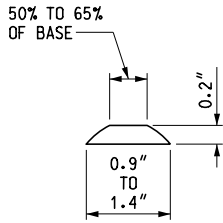

DOME SECTION

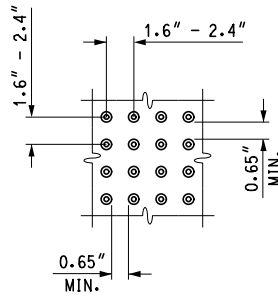

DOME SPACING

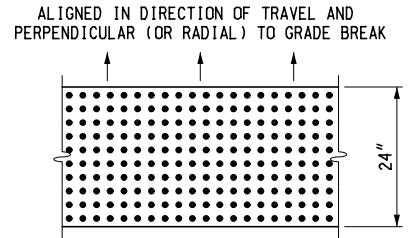

DOME ALIGNMENT

DETECTABLE WARNING DETAILS

NOTES:

DETAILS SPECIFIED ON THIS PLAN APPLY TO ALL CONSTRUCTION, RECONSTRUCTION, OR ALTERATION OF STREETS, CURBS, OR SIDEWALKS IN THE PUBLIC RIGHT OF WAY.

CURB RAMP ARE TO BE LOCATED AS SPECIFIED ON THE PLANS OR AS DIRECTED BY THE ENGINEER.

RAMP SHALL BE PROVIDED AT ALL CORNERS OF AN INTERSECTION WHERE THERE IS EXISTING OR PROPOSED SIDEWALK AND CURB. RAMP SHALL ALSO BE PROVIDED AT MARKED AND/OR SIGNALIZED MID-BLOCK CROSSINGS.

SURFACE TEXTURE OF THE RAMP SHALL BE THAT OBTAINED BY A COARSE BROOMING, TRANSVERSE TO THE RUNNING SLOPE.

SIDEWALK SHALL BE RAMPED WHERE THE DRIVEWAY CURB IS EXTENDED ACROSS THE WALK.

CARE SHALL BE TAKEN TO ASSURE A UNIFORM GRADE ON THE RAMP. WHERE CONDITIONS PERMIT, IT IS DESIRABLE THAT THE SLOPE OF THE RAMP BE IN ONLY ONE DIRECTION, PARALLEL TO THE DIRECTION OF TRAVEL.

RAMP WIDTH SHALL BE INCREASED, IF NECESSARY, TO ACCOMMODATE SIDEWALK SNOW REMOVAL EQUIPMENT NORMALLY USED BY THE MUNICIPALITY.

WHEN 5' MINIMUM WIDTHS ARE NOT PRACTICABLE, RAMP WIDTH MAY BE REDUCED TO NOT LESS THAN 4' AND LANDINGS TO NOT LESS THAN 4' x 4'.

CURB RAMP WITH A RUNNING SLOPE $\leq 5\%$ DO NOT REQUIRE A TOP LANDING. HOWEVER, ANY CONTINUOUS SIDEWALK OR PEDESTRIAN ROUTE CROSSING THROUGH OR INTERSECTING THE CURB RAMP MUST INDEPENDENTLY MAINTAIN A CROSS SLOPE NOT GREATER THAN 2% PERPENDICULAR TO ITS OWN DIRECTION(S) OF TRAVEL.

DETECTABLE WARNING SURFACE COVERAGE IS 24" MINIMUM IN THE DIRECTION OF RAMP/PATH TRAVEL AND THE FULL WIDTH OF THE RAMP/PATH OPENING EXCLUDING CURBED OR FLARED CURB TRANSITION AREAS. A BORDER OFFSET NOT GREATER THAN 2" MEASURED ALONG THE EDGES OF THE DETECTABLE WARNING IS ALLOWABLE. FOR RADIAL CURB THE OFFSET IS MEASURED FROM THE ENDS OF THE RADIUS.

FOR NEW ROADWAY CONSTRUCTION, THE RAMP CROSS SLOPE MAY NOT EXCEED 2.0%. FOR ALTERATIONS TO EXISTING ROADWAYS, THE CROSS SLOPE MAY BE TRANSITIONED TO MEET AN EXISTING ROADWAY GRADE. THE CROSS SLOPE TRANSITION SHALL BE APPLIED UNIFORMLY OVER THE FULL LENGTH OF THE RAMP.

THE MAXIMUM RUNNING SLOPE OF 8.3% IS RELATIVE TO A FLAT (0%) REFERENCE. HOWEVER, IT SHALL NOT REQUIRE ANY RAMP OR SERIES OF RAMP TO EXCEED 15 FEET IN LENGTH NOT INCLUDING LANDINGS OR TRANSITIONS.

DRAINAGE STRUCTURES SHOULD NOT BE PLACED IN LINE WITH RAMP. THE LOCATION OF THE RAMP SHOULD TAKE PRECEDENCE OVER THE LOCATION OF THE DRAINAGE STRUCTURE. WHERE EXISTING DRAINAGE STRUCTURES ARE LOCATED IN THE RAMP PATH OF TRAVEL, USE A MANUFACTURER'S ADA COMPLIANT GRATE. OPENINGS SHALL NOT BE GREATER THAN 1/2". ELONGATED OPENINGS SHALL BE PLACED SO THAT THE LONG DIMENSION IS PERPENDICULAR TO THE DOMINANT DIRECTION OF TRAVEL.

THE TOP OF THE JOINT FILLER FOR ALL RAMP TYPES SHALL BE FLUSH WITH THE ADJACENT CONCRETE.

CROSSWALK AND STOP LINE MARKINGS, IF USED, SHALL BE SO LOCATED AS TO STOP TRAFFIC SHORT OF RAMP CROSSINGS. SPECIFIC DETAILS FOR MARKING APPLICATIONS ARE GIVEN IN THE "MICHIGAN MANUAL ON UNIFORM TRAFFIC CONTROL DEVICES".

FLARED SIDES WITH A SLOPE OF 10% MAXIMUM, MEASURED ALONG THE ROADSIDE CURB LINE, SHALL BE PROVIDED WHERE AN UNOBSTRUCTED CIRCULATION PATH LATERALLY CROSSES THE CURB RAMP. FLARED SIDES ARE NOT REQUIRED WHERE THE RAMP IS BORDERED BY LANDSCAPING, UNPAVED SURFACE OR PERMANENT FIXED OBJECTS. WHERE THEY ARE NOT REQUIRED, FLARED SIDES CAN BE CONSIDERED IN ORDER TO AVOID SHARP CURB RETURNS AT RAMP OPENINGS.

DETECTABLE WARNING PLATES MUST BE INSTALLED USING FABRICATED OR FIELD CUT UNITS CAST AND/OR ANCHORED IN THE PAVEMENT TO RESIST SHIFTING OR HEAVING.

MICHIGAN DEPARTMENT OF TRANSPORTATION
BUREAU OF DEVELOPMENT STANDARD PLAN FOR

CURB RAMP AND
DETECTABLE WARNING DETAILS

4-7-2022 F.H.W.A. APPROVAL	5-8-2020 PLAN DATE	R-28-J	SHEET 7 OF 7
-------------------------------	-----------------------	--------	-----------------

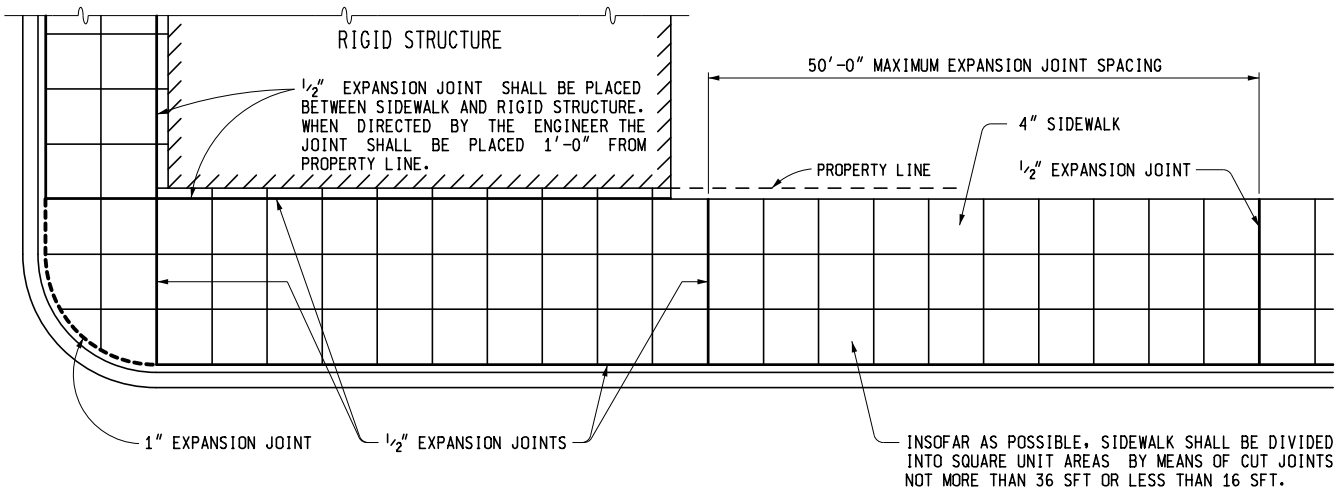
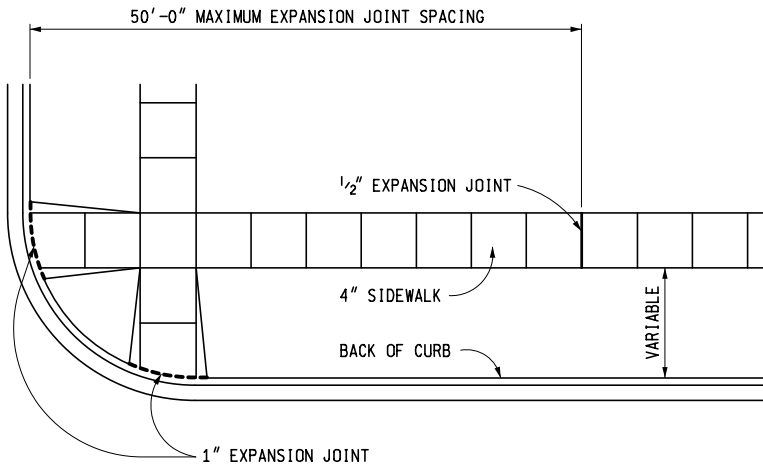

LOCATION OF JOINTS IN CONCRETE SIDEWALK

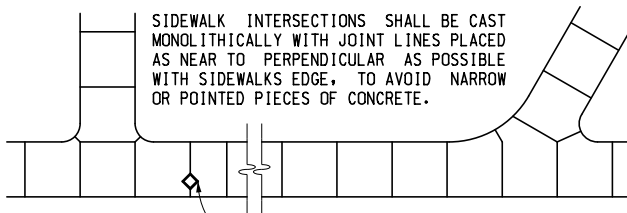

WHERE A PERMANENT STRUCTURE IS LOCATED IN SIDEWALK, PLACE EXPANSION MATERIAL AROUND STRUCTURE AND ADJUST JOINT PATTERN TO INTERSECT STRUCTURE AS ILLUSTRATED.

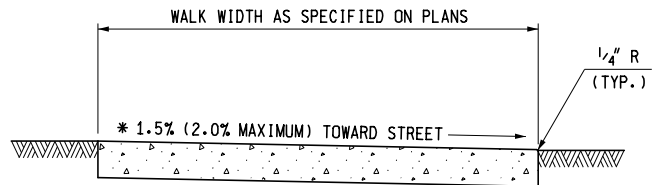

* SEE NOTES

TYPICAL SIDEWALK JOINT LAYOUTS

4" CONCRETE SIDEWALK



PREPARED BY
DESIGN DIVISION

DRAWN BY: B.L.T.
CHECKED BY: W.K.P.

DEPARTMENT DIRECTOR
Kirk T. Stuedle

APPROVED BY: *Randy Van Pelt*
DIRECTOR, BUREAU OF FIELD SERVICES

APPROVED BY: *Mark A. Van Pelt*
DIRECTOR, BUREAU OF HIGHWAY DEVELOPMENT

MICHIGAN DEPARTMENT OF TRANSPORTATION
BUREAU OF HIGHWAY DEVELOPMENT STANDARD PLAN FOR

**DRIVEWAY OPENINGS
& APPROACHES,
AND CONCRETE SIDEWALK**

9-30-2014
F.H.W.A. APPROVAL

7-1-2014
PLAN DATE

R-29-I

SHEET
1 OF 4

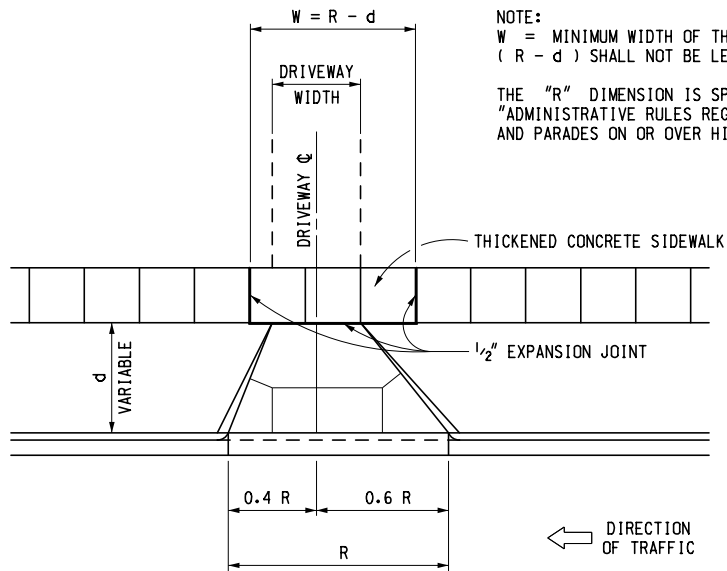

NOTE:
 W = MINIMUM WIDTH OF THICKENED CONCRETE SIDEWALK.
 (R - d) SHALL NOT BE LESS THAN DRIVEWAY WIDTH.

THE "R" DIMENSION IS SPECIFIED IN THE PUBLICATION
 "ADMINISTRATIVE RULES REGULATING DRIVEWAYS, BANNERS
 AND PARADES ON OR OVER HIGHWAYS".

CONCRETE DRIVEWAY OPENING LAYOUT

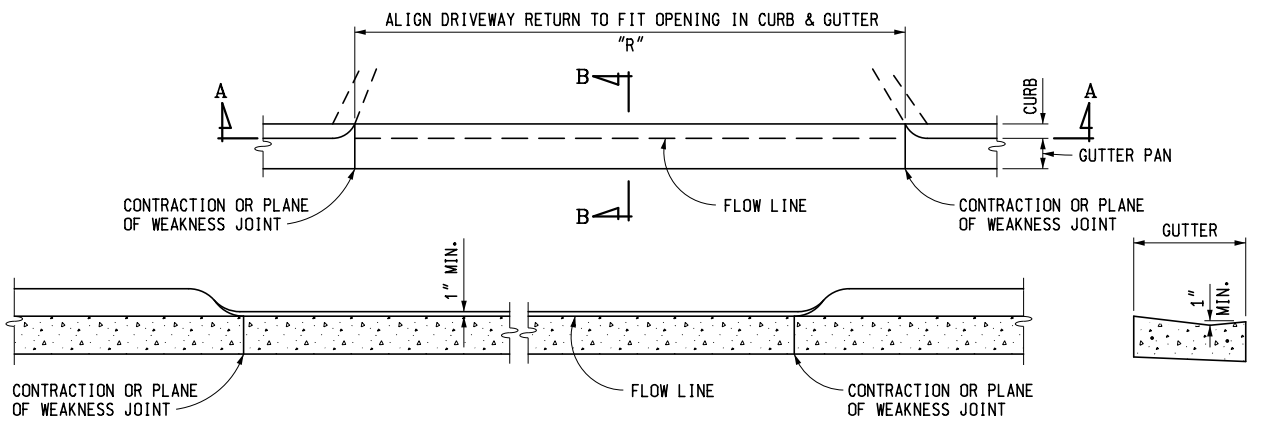

CONCRETE DRIVEWAY OPENING, DETAIL L

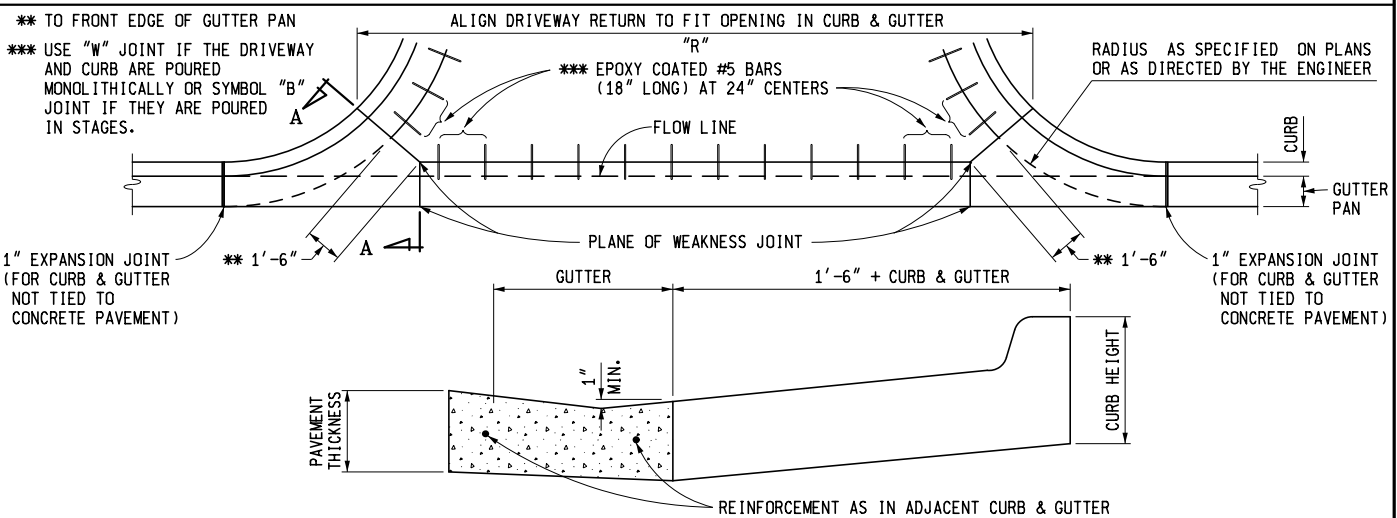

CONCRETE DRIVEWAY OPENING, DETAIL M

NOTE:
 FOR ROADWAYS WITH CONCRETE PAVEMENTS, LONGITUDINAL LANE TIES WILL
 BE CONTINUOUS THROUGH THE DRIVEWAY OPENING AND THE SPACING OF THE
 #5 BARS IN CONCRETE DRIVEWAYS SHALL BE ADJUSTED TO AVOID CONFLICT
 WITH THE LONGITUDINAL LANE TIES.

MICHIGAN DEPARTMENT OF TRANSPORTATION
 BUREAU OF HIGHWAY DEVELOPMENT STANDARD PLAN FOR

**DRIVEWAY OPENINGS
 & APPROACHES,
 AND CONCRETE SIDEWALK**

9-30-2014 F.H.W.A. APPROVAL	7-1-2014 PLAN DATE	R-29-I	SHEET 2 OF 4
--------------------------------	-----------------------	--------	-----------------

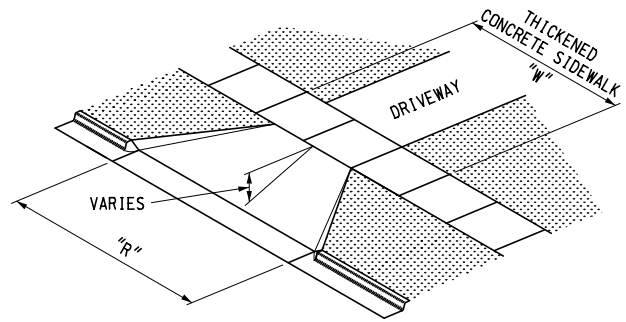
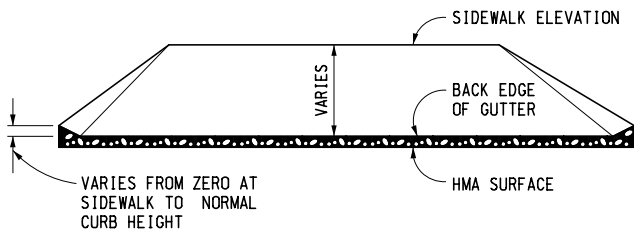

HMA DRIVEWAY APPROACH
(TO BE USED WITH DETAIL L)

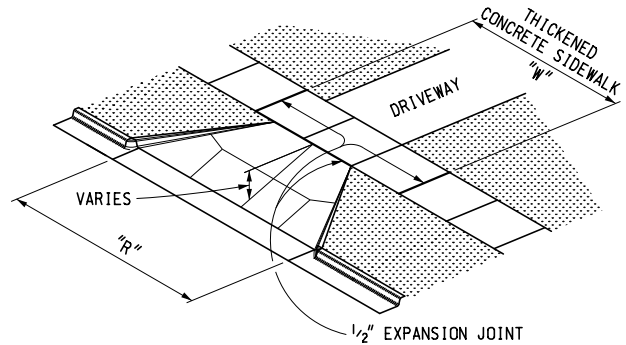
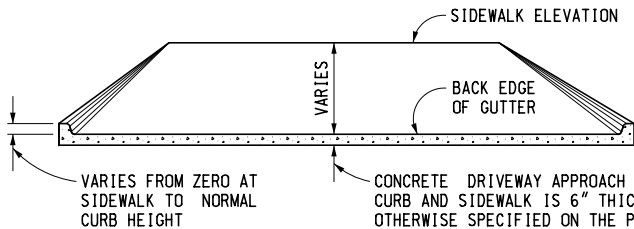

NOTES:

MONOLITHIC CURB IS INCLUDED IN THE CONCRETE DRIVEWAY APPROACH QUANTITY.

REINFORCEMENT IS NOT REQUIRED UNLESS SPECIFIED ON THE PLANS. WHEN REINFORCEMENT IS SPECIFIED, SEE CHART ON THIS SHEET.

CONCRETE DRIVEWAY APPROACH
(TO BE USED WITH DETAIL L OR M)

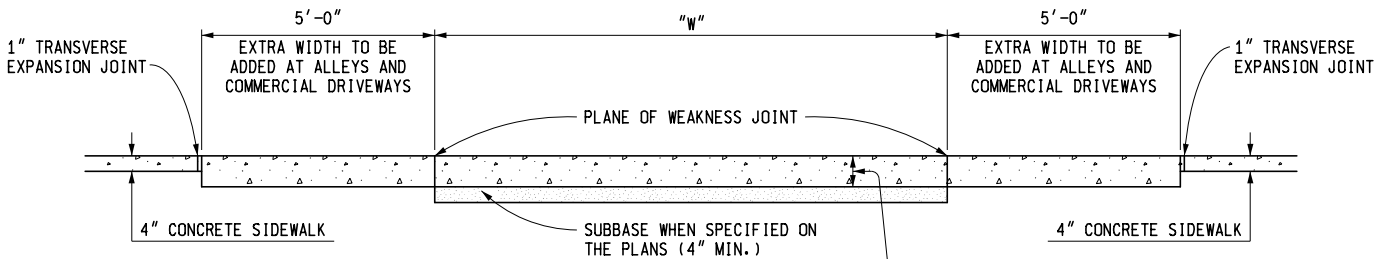

WHEN CONCRETE DRIVEWAY APPROACH IS SPECIFIED, THE THICKENED CONCRETE SIDEWALK THICKNESS IS EQUAL TO THE THICKNESS OF THE CONCRETE DRIVEWAY APPROACH. WHEN HMA DRIVEWAY APPROACH IS SPECIFIED, THE THICKENED CONCRETE SIDEWALK THICKNESS IS 6" MIN.

THICKENED CONCRETE SIDEWALK

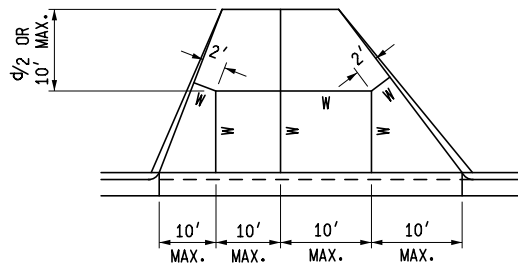

ADJUST DRIVEWAY JOINTS AS NEEDED TO ALIGN WITH ANY COINCIDING TRANSVERSE PAVEMENT JOINTS,

JOINT LAYOUT IS AS INDICATED OR AS DIRECTED BY THE ENGINEER.

INTERMEDIATE DRIVEWAY JOINT DETAILS

REINFORCEMENT FOR CONCRETE DRIVEWAYS

CONCRETE DRIVEWAY THICKNESS	WIRE SIZE (6" x 6" MESH)	AVERAGE WEIGHT (LBS/100 SFT)
LESS THAN 8"	W1.4	21
	W2.9	42
8" OR GREATER	USE WIRE FABRIC REINFORCEMENT SPECIFIED ON STANDARD PLAN R-37-SERIES	

MICHIGAN DEPARTMENT OF TRANSPORTATION
BUREAU OF HIGHWAY DEVELOPMENT STANDARD PLAN FOR

DRIVEWAY OPENINGS & APPROACHES, AND CONCRETE SIDEWALK

9-30-2014
F.H.W.A. APPROVAL

7-1-2014
PLAN DATE

R-29-I

SHEET
3 OF 4

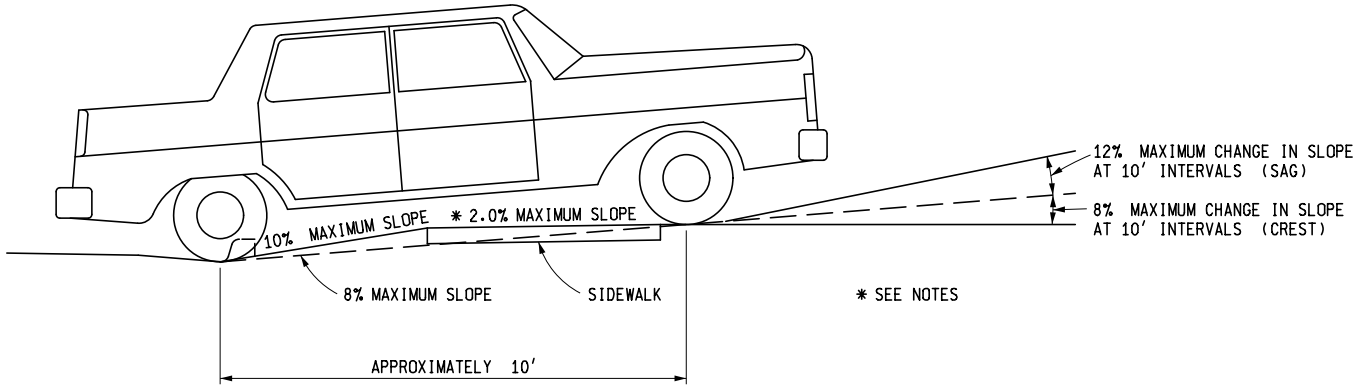

LOW VOLUME COMMERCIAL OR RESIDENTIAL DRIVEWAY SLOPES

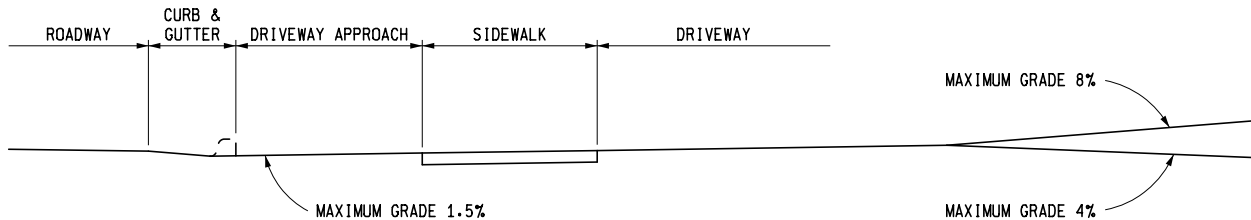

COMMERCIAL DRIVEWAY PROFILE FOR MAJOR TRAFFIC GENERATORS

NOTES:

FOR DRIVEWAY DESIGN REFER ALSO TO "ADMINISTRATIVE RULES REGULATING DRIVEWAYS, BANNERS, AND PARADES ON OR OVER HIGHWAYS" AND GEOMETRIC DESIGN G-680-SERIES, COMMERCIAL DRIVEWAYS.

FOR CURB AND GUTTER DETAILS, SEE STANDARD PLAN R-30-SERIES.

TRANSVERSE SIDEWALK SLOPES ARE TYPICALLY 1.5% (2.0% MAXIMUM). IN ORDER TO MEET SITE CONDITIONS, IF THE TRANSVERSE SLOPE IS REQUIRED TO BE LESS THAN 1.5%, LONGITUDINAL DRAINAGE MUST BE PROVIDED.

WHEN SETTING GRADES FOR COMMERCIAL DRIVES, THE TYPES OF VEHICLES USING THE DRIVE SHOULD BE CONSIDERED.

MICHIGAN DEPARTMENT OF TRANSPORTATION BUREAU OF HIGHWAY DEVELOPMENT STANDARD PLAN FOR DRIVEWAY OPENINGS & APPROACHES, AND CONCRETE SIDEWALK		
9-30-2014 F.H.W.A. APPROVAL	7-1-2014 PLAN DATE	R-29-I
		SHEET 4 OF 4

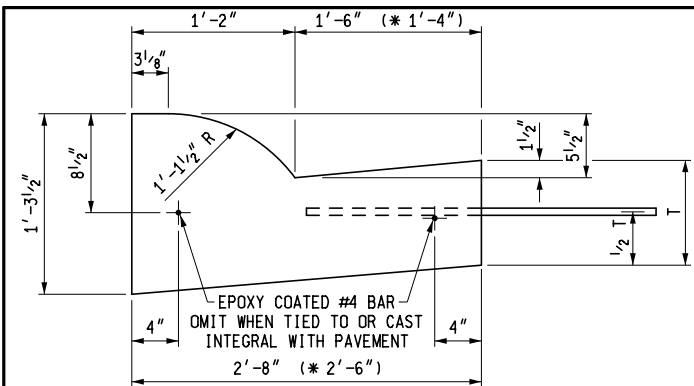

(* GUTTER PAN WIDTH MAY BE REDUCED WHEN APPROVED BY THE ENGINEER)

DETAIL	DIMENSION	LANE TIES	CONCRETE CYD / LFT	CONCRETE CYD / LFT
	T			
B1	9"	AS SHOWN	0.0900	(* 0.0855)
B2	9"	OMITTED	0.0900	(* 0.0855)
B3	10"	AS SHOWN	0.0941	(* 0.0894)

B

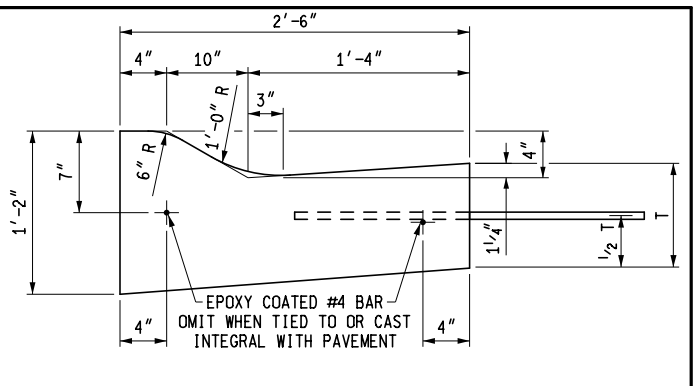

DETAIL	DIMENSION	LANE TIES	CONCRETE CYD / LFT
	T		
D1	9"	AS SHOWN	0.0788
D2	9"	OMITTED	0.0788
D3	10"	AS SHOWN	0.0826

D

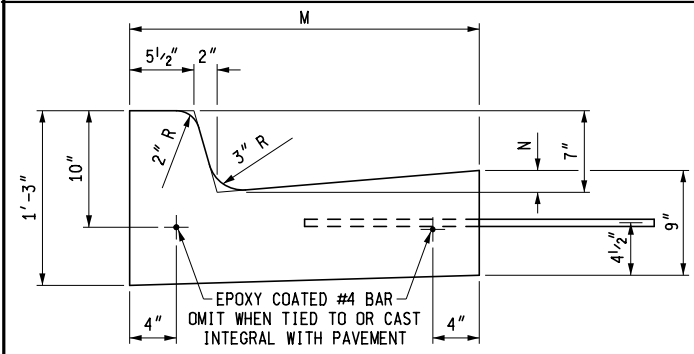

DETAIL	DIMENSION		LANE TIES	CONCRETE CYD / LFT
	M	N		
C1	1'-6"	7/8"	AS SHOWN	0.0506
C2	1'-6"	7/8"	OMITTED	0.0506
C3	2'-0"	1 3/8"	AS SHOWN	0.0632
C4	2'-0"	1 3/8"	OMITTED	0.0632
C5	2'-6"	1 7/8"	AS SHOWN	0.0757
C6	2'-6"	1 7/8"	OMITTED	0.0757

C

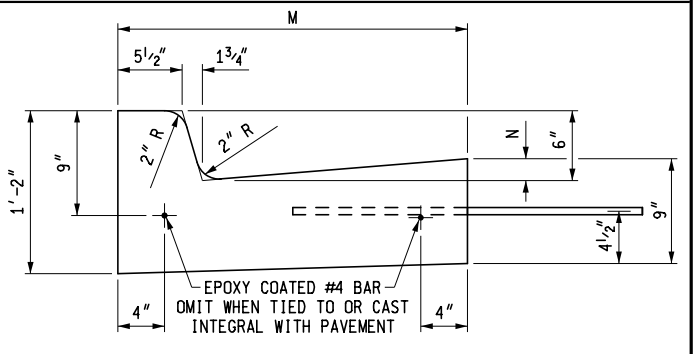

DETAIL	DIMENSION		LANE TIES	CONCRETE CYD / LFT
	M	N		
F1	1'-6"	7/8"	AS SHOWN	0.0484
F2	1'-6"	7/8"	OMITTED	0.0484
F3	2'-0"	1 3/8"	AS SHOWN	0.0610
F4	2'-0"	1 3/8"	OMITTED	0.0610
F5	2'-6"	1 7/8"	AS SHOWN	0.0737
F6	2'-6"	1 7/8"	OMITTED	0.0737

F

* WHEN OTHER THAN 7" (4" MIN. TO 9" MAX.)
FACE EXPOSURE IS SPECIFIED ON PLANS. VARY
TOTAL CURB HEIGHT AND BATTER ACCORDINGLY

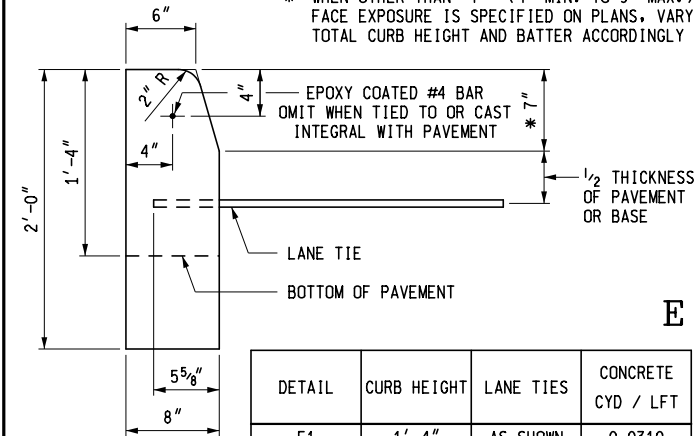

DETAIL	CURB HEIGHT	LANE TIES	CONCRETE CYD / LFT
E1	1'-4"	AS SHOWN	0.0310
E2	1'-4"	OMITTED	0.0310
E4	2'-0"	OMITTED	0.0477

E

MDOT
Michigan Department of Transportation

PREPARED BY
DESIGN DIVISION

DRAWN BY: B.L.T.

CHECKED BY: W.K.P.

DEPARTMENT DIRECTOR
Kirk T. Stuedle

APPROVED BY: Randy V. [Signature]
DIRECTOR, BUREAU OF FIELD SERVICES

APPROVED BY: Mark A. Van [Signature]
DIRECTOR, BUREAU OF HIGHWAY DEVELOPMENT

MICHIGAN DEPARTMENT OF TRANSPORTATION
BUREAU OF HIGHWAY DEVELOPMENT STANDARD PLAN FOR

**CONCRETE CURB AND
CONCRETE CURB & GUTTER**

9-30-2014 F.H.W.A. APPROVAL	2-6-2014 PLAN DATE	R-30-G	SHEET 1 OF 2
--------------------------------	-----------------------	---------------	-----------------

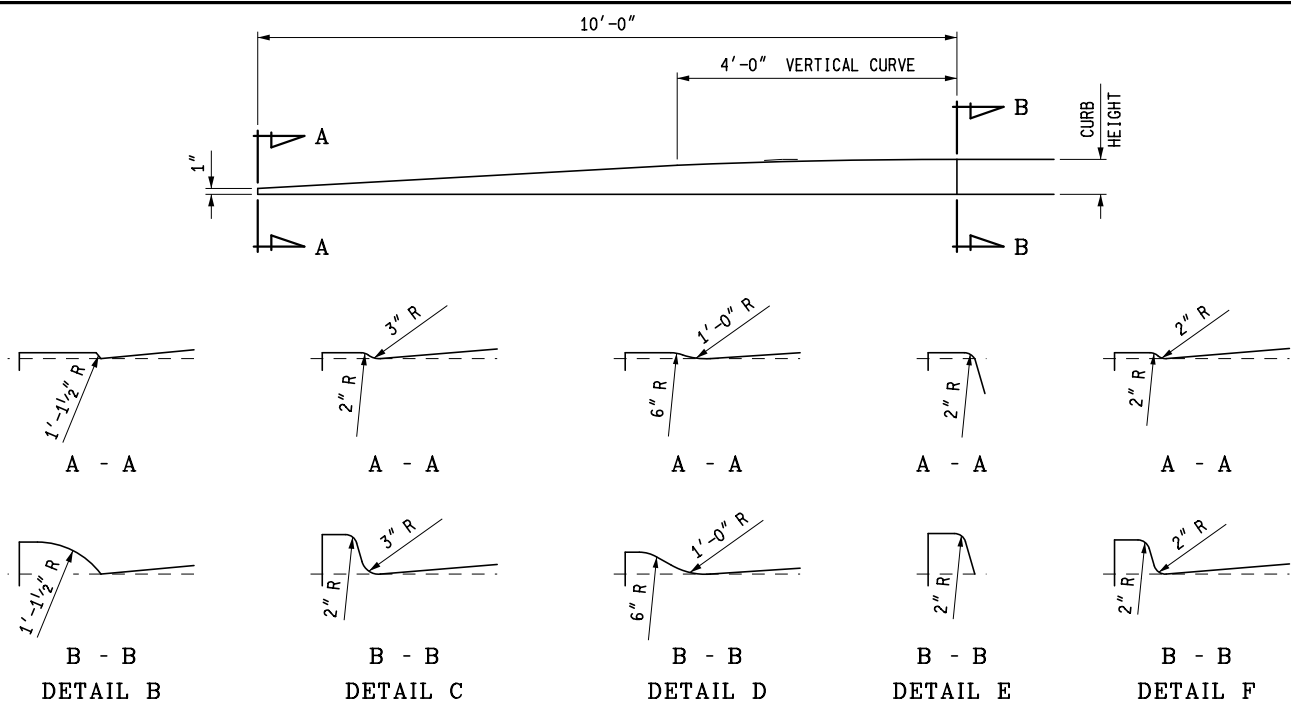

CONCRETE CURB, CURB AND GUTTER ENDINGS

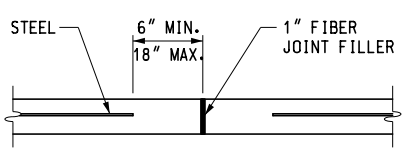

1" FIBER JOINT FILLER

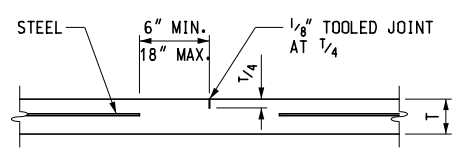

CONTRACTION JOINT

NOTES:

- CURB AND GUTTER RADII SHALL BE DIMENSIONED TO THE FRONT EDGE OF THE GUTTER PAN OR EDGE OF PAVEMENT.
- CONCRETE CURB AND GUTTER ENDINGS WILL BE PAID FOR IN LINEAR FEET OF THE ADJACENT CURB DETAIL.
- JOINTS SHALL BE PLACED AT RIGHT ANGLES TO THE EDGE OF CONCRETE CURB AND GUTTER.
- JOINTS DETAILED ON THE PLANS SHALL SUPERSEDE THOSE SPECIFIED ON THIS STANDARD PLAN.
- BOTTOM SLOPE OF CURB AND GUTTER STRUCTURE MAY BE THE SAME SLOPE AS BOTTOM OF PAVEMENT. BACK OF CURB AND VERTICAL EDGE OF GUTTER PAN MAY HAVE A MAXIMUM 1/2" BATTER TO FACILITATE FORMING.
- WHEN CURB AND GUTTER IS CAST INTEGRALLY, SEE CURRENT STANDARD PLAN R-31-SERIES.
- ALL JOINTS FOR CURB OR CURB AND GUTTER ARE INCLUDED IN THE PAY ITEM FOR THE CURB OR CURB AND GUTTER.

JOINTS IN CURB OR CURB AND GUTTER NOT TIED TO CONCRETE PAVEMENT; ADJACENT TO CONCRETE BASE COURSE; OR ADJACENT TO HMA PAVEMENT:

- A. PLACE 1" FIBER JOINT FILLER AT 400' MAXIMUM INTERVALS.
- B. PLACE 1" FIBER JOINT FILLER AT SPRING POINTS OF INTERSECTING STREETS.
- C. PLACE 1/2" ISOLATION JOINT AT CATCH BASINS PER STANDARD PLAN R-37-SERIES.
- D. PLACE CONTRACTION JOINTS AT 40' MAXIMUM INTERVALS.

JOINTS IN CURB OR CURB AND GUTTER TIED TO JOINTED PAVEMENT

- A. PLACE 1" FIBER JOINT FILLER OPPOSITE ALL TRANSVERSE EXPANSION JOINTS IN PAVEMENT.
- B. PLACE 1/2" ISOLATION JOINT AT CATCH BASINS PER STANDARD PLAN R-37-SERIES.
- C. PLACE CONTRACTION JOINTS OPPOSITE ALL TRANSVERSE CONTRACTION JOINTS IN PAVEMENT.
- D. A SYMBOL (B) JOINT SHALL BE PLACED BETWEEN CURB OR CURB AND GUTTER AND ADJACENT CONCRETE PAVEMENT AS SPECIFIED ON STANDARD PLAN R-41-SERIES.

MICHIGAN DEPARTMENT OF TRANSPORTATION
BUREAU OF HIGHWAY DEVELOPMENT STANDARD PLAN FOR

**CONCRETE CURB AND
CONCRETE CURB & GUTTER**

9-30-2014 F.H.W.A. APPROVAL	2-6-2014 PLAN DATE	R-30-G	SHEET 2 OF 2
--------------------------------	-----------------------	--------	-----------------

Notes for Figure 6H-28—Typical Application 28
Sidewalk Detour or Diversion

Standard:

1. **When crosswalks or other pedestrian facilities are closed or relocated, temporary facilities shall be detectable and shall include accessibility features consistent with the features present in the existing pedestrian facility.**

Guidance:

2. *Where high speeds are anticipated, a temporary traffic barrier and, if necessary, a crash cushion should be used to separate the temporary sidewalks from vehicular traffic.*
3. *Audible information devices should be considered where midblock closings and changed crosswalk areas cause inadequate communication to be provided to pedestrians who have visual disabilities.*

Option:

4. Street lighting may be considered.
5. Only the TTC devices related to pedestrians are shown. Other devices, such as lane closure signing or ROAD NARROWS signs, may be used to control vehicular traffic.
6. For nighttime closures, Type A Flashing warning lights may be used on barricades that support signs and close sidewalks.
7. Type C Steady-Burn or Type D 360-degree Steady-Burn warning lights may be used on channelizing devices separating the temporary sidewalks from vehicular traffic flow.
8. Signs, such as KEEP RIGHT (LEFT), may be placed along a temporary sidewalk to guide or direct pedestrians.



Figure 6H-28. Sidewalk Detour or Diversion (TA-28)

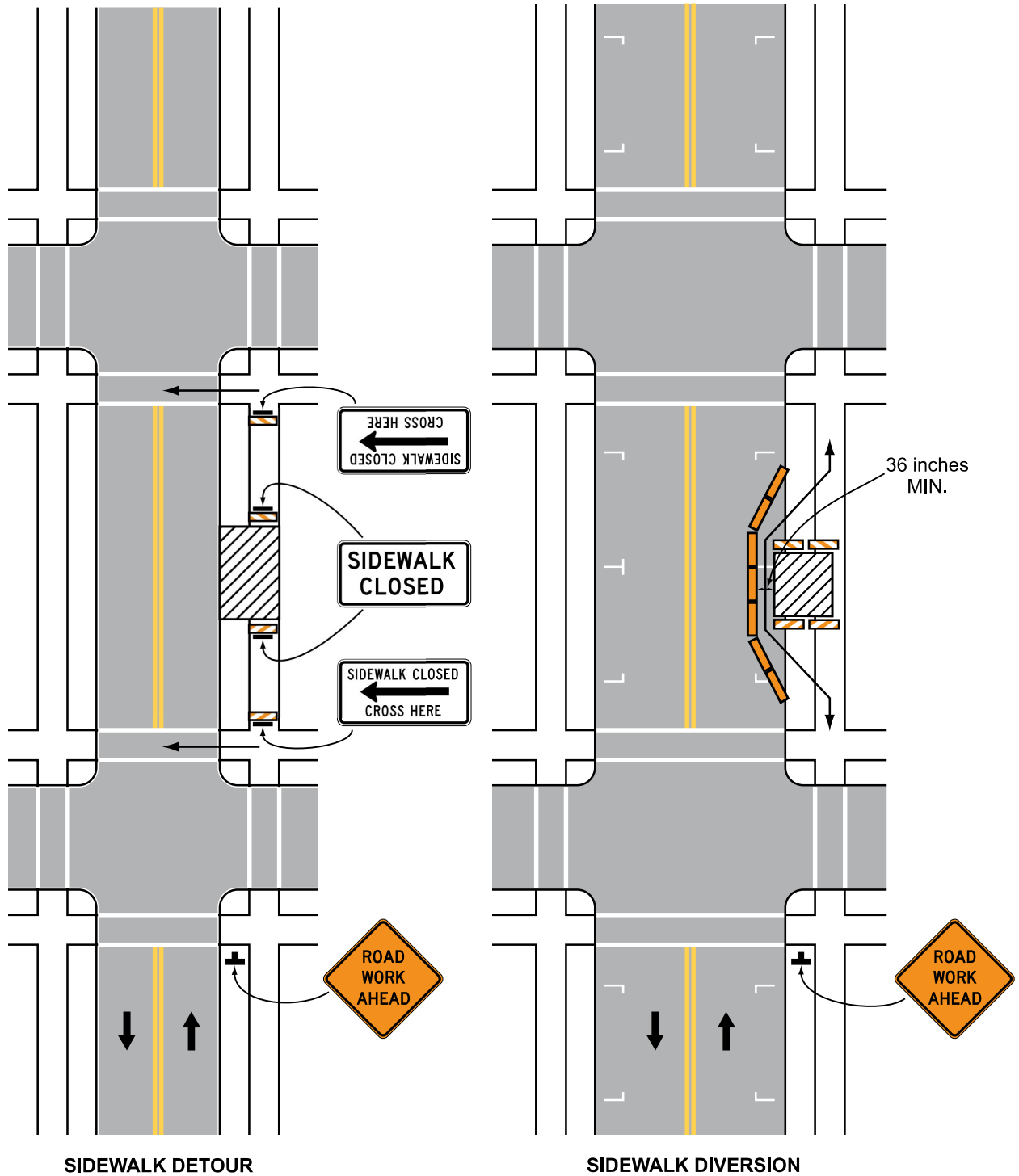

Typical Application 28

Note: See Tables 6H-2 and 6H-3 for the meaning of the symbols and/or letter codes used in this figure.

Notes for Figure 6H-29—Typical Application 29

Crosswalk Closures and Pedestrian Detours

Standard:

1. When crosswalks or other pedestrian facilities are closed or relocated, temporary facilities shall be detectable and shall include accessibility features consistent with the features present in the existing pedestrian facility.
2. Curb parking shall be prohibited for at least 50 feet in advance of the midblock crosswalk.

Guidance:

3. Audible information devices should be considered where midblock closings and changed crosswalk areas cause inadequate communication to be provided to pedestrians who have visual disabilities.
4. Pedestrian traffic signal displays controlling closed crosswalks should be covered or deactivated.

Option:

5. Street lighting may be considered.
6. Only the TTC devices related to pedestrians are shown. Other devices, such as lane closure signing or ROAD NARROWS signs, may be used to control vehicular traffic.
7. For nighttime closures, Type A Flashing warning lights may be used on barricades supporting signs and closing sidewalks.
8. Type C Steady-Burn or Type D 360-degree Steady-Burn warning lights may be used on channelizing devices separating the work space from vehicular traffic.
9. In order to maintain the systematic use of the fluorescent yellow-green background for pedestrian, bicycle, and school warning signs in a jurisdiction, the fluorescent yellow-green background for pedestrian, bicycle, and school warning signs may be used in TTC zones.

Figure 6H-29. Crosswalk Closures and Pedestrian Detours (TA-29)

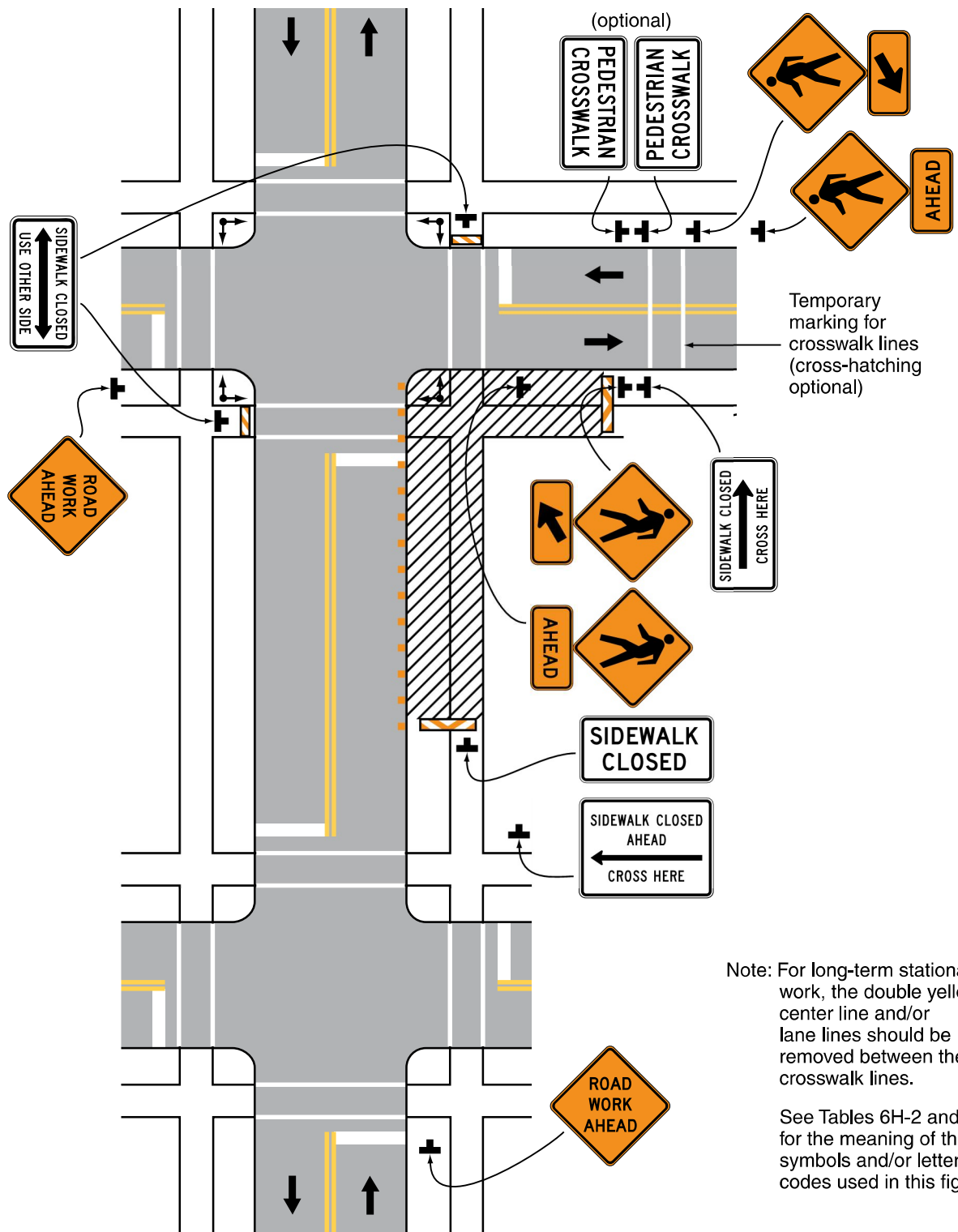

Note: For long-term stationary work, the double yellow center line and/or lane lines should be removed between the crosswalk lines.

See Tables 6H-2 and 6H-3 for the meaning of the symbols and/or letter codes used in this figure.

Typical Application 29

APPENDIX D



**THE CITY OF KALAMAZOO
DEPARTMENT OF PUBLIC SERVICES
ENGINEERING DIVISION**

SPECIAL PROVISIONS

ACADEMY STREET SIDEWALK IMPROVEMENT

Bid Reference #: 91347.008.0

CITY OF KALAMAZOO

SPECIAL PROVISION

FOR

MAINTAINING TRAFFIC

COK

Page 1 of 4

8/13/2025

a. Description. This work shall consist of maintaining construction zone traffic and placing traffic control devices for Sidewalk Repair Project and any affected side streets as described in this special provision and as directed by the Engineer in the City of Kalamazoo, Michigan.

b. Materials. Provide material in accordance with Sections 812 and 922 of the Michigan Department of Transportation (MDOT) Standard Specifications for Construction.

c. Storage of Materials. Location for storage of materials shall be addressed by the contractor in the City ROW permit and approved by the Engineer prior to the commencement of work. All maintenance of traffic materials shall be stored in the approved location(s). Any items not stored in the proper location shall be corrected no later than 24 hours after notice is given by the Engineer. Items found not stored in the approved locations or not corrected within the allotted time shall be grounds for the City to withhold payment for maintenance of traffic until corrected.

d. Construction. Traffic shall be maintained according to Chapter 6 of the Michigan Manual on Uniform Traffic Control Devices (MMUTCD) Guide to Sections 104.07, 104.11, 812, and 922 of the MDOT Standard Specifications for Construction, including any Supplemental Specifications, and as specified here.

1. The Contractor shall notify the Project Engineer a minimum of 72 hours prior to the implementation of any detours, road closures, shoulder closures, or lane closures.

2. The Contractor shall coordinate all operations with Contractors performing work on other projects within or adjacent to the Construction Influence Area (CIA).

3. City of Kalamazoo (City), maintenance crews and/or Contract Maintenance Agencies may perform maintenance work within or adjacent to the CIA. The City and/or Contract Maintenance Agency will coordinate their operations with the Engineer to minimize the interference to the Contractor. No additional payment will be made to the Contractor for the joint use of the traffic control items.

4. The Contractor shall provide a traffic control plan for each phase of the project to the Engineer for approval by the Traffic Safety Department and the Engineer prior to beginning work requiring traffic control. The traffic control plan shall include all temporary signage, type II barricades, type III barricades, plastic drums, etc. and appropriate temporary pavement markings where needed.

5.: Construction Influence Area (CIA). The CIA shall include the right-of-way of Academy St from Park St to Rose St.

6. Traffic Restrictions and Construction Requirements.

A. All work shall be conducted during daytime hours unless otherwise specified herein or approved by the Engineer. Night work may be permitted at the discretion of the Engineer. However, any additional cost for such work shall be borne by the Contractor.

B. Access for construction vehicles between the travel lanes and work areas will be restricted to specific locations. The number of access points and their locations will require the prior approval of the Engineer.

C. Undercuts or excavations immediately adjacent to active traffic lanes shall be restored to no less than a 1 on 4 slope at the end of each working period unless otherwise approved by the Engineer. Fencing shall be required to protect open trenches during non- working hours and shall be provided by the Contractor as part of the trenching item utilized.

D. Duration of driveway and alley closures shall be minimized. Contractor shall provide property owners with written notice a minimum of four (4) business days prior to the anticipated driveway and alley closure, and shall inform residents of the anticipated duration of the driveway or alley closure.

E. The Contractor shall maintain and coordinate daily waste pickup and deliveries to all business buildings affected by driveway, alley and road closures for this project.

F. Sidewalks or pathways in the project area shall be maintained at all times except in areas where sidewalk or pathway removal and replacement are ongoing. Sidewalk or pathways removed shall be replaced as soon as is feasibly possible.

G. Ingress and egress to all buildings and parking areas for pedestrians and vehicles shall be maintained.

H. Keep all side streets and alleys free of construction related materials, equipment, and activities to allow clear visibility and access to all properties and businesses.

I. Contractors, employees, and subcontractors shall not park vehicles or store equipment in areas that are needed for residential or adjacent commercial parking and at no time shall vehicles be parked or equipment stored on private property unless written permission is obtained from the property owner. Also, Contractors, employees and subcontractors shall not drive construction equipment of any kind on private property without written permission of the property owner.

J. Construction equipment and material storage shall not be allowed on top of existing areaways, pathways or sidewalks.

K. Street name signs shall be maintained within the construction area for the duration of the project. Street name signs shall be visible from all intersection corners. If the existing street name sign and support are to be removed, and there is no alternate support available, the Contractor shall erect a separate post & street name sign for this

purpose. The cost for this work shall not be paid for separately but considered incidental to the pay items included for maintaining traffic.

L. Removing, obstructing, relocating or otherwise tampering with a regulatory traffic sign is prohibited unless approved by the Engineer and the City Traffic Safety Department. Where a conflict is foreseen or encountered, the sign(s) may be removed by the Contractor only upon installation of temporary signs(s) placed in accordance with the Michigan Manual of Uniform Traffic Control Devices (MMUTCD) at location(s) approved by the Engineer. Temporary signs shall be maintained by the Contractor until the existing permanent signs are reinstalled. The cost for this work shall be incidental to the pay items included for maintaining traffic.

7. Traffic Control Devices.

A. General

- i. All traffic control devices and their usage shall conform to the most current revision of Part 6 of the Michigan Manual of Uniform Traffic Control Devices (MMUTCD).
- ii. During non-working periods, any work site with uncompleted work shall have advance signs (W21-4 - "Road Work Ahead") and plastic drums, at specific locations, as directed by the Engineer.

B. Temporary Signs

- i. Tables for "L", "D" and "B" values are provided in MDOT Traffic and Safety Figure M0020a.
- ii. Temporary signs shall be on ground driven sign supports as shown in MDOT Traffic and Safety Figure WZD-100-A.
- iii. The signing for a one or two lane closure and traffic shift shall be as shown in the MDOT Traffic and Safety Figure M0240a and M0120a..
- iv. All diamond-shaped warning signs shall be 48 inch x 48 inch mounted at a 7 foot minimum bottom height in curbed or pedestrian areas.
- v. Distances between construction warning, regulatory and guide signs shown on the Figures are approximate and may require field adjustment, as directed by the Engineer.
- vi. All temporary signs shall be constructed with legends and symbols flush to the sign face and not extending beyond the sign borders or edges.
- vii. All temporary signs shall be faced with prismatic retroreflective sheeting.

viii. Whenever a lane or obstruction is removed, all related construction signs shall be removed, turned away from traffic or otherwise made not visible to traffic.

C. Channelizing Devices

- i. Channeling devices required for maintaining one lane of traffic in each direction shall be Channelizing Device, 42 inch.

e. Measurement and Payment. The completed work shall be paid for at the contract unit price which shall include all materials, equipment and labor required to complete this work. Pay items are listed in the contract and invitation for bid documents.

CITY OF KALAMAZOO

SPECIAL PROVISION

FOR

PAVT, REM, MODIFIED

COK

Page 1 of 1

1/18/2023

a. Description. This work consists of removing HMA, concrete, bricks and masonry and any other common pavement material or combination of materials, except sand and gravel, regardless of thickness, reinforcement and overlays.

b. Materials. None Specified

c. Construction Methods. Remove pavement to an existing joint or sawed joint. Saw cut pavement full depth in a straight neat line as directed by the Engineer. Do not use a crane and ball pavement breaker. Do not disturb remaining pavement. Assume ownership of removed materials and dispose of according to subsection 205.03P.

d. Measurement and Payment. The completed work, as described, will be measured and paid for at the contract unit price using the following pay item:

Contract Item (Pay Item)

Pay Unit

Pavt, Rem, Modified.....SYD

The limits of Pavt, Rem, Modified will be established as noted on the plans or at the discretion of the Engineer. The unit price includes all labor, equipment, and materials to saw cut, remove, haul and dispose of the pavement.

CITY OF KALAMAZOO

SPECIAL PROVISION

FOR

CURB AND GUTTER, REM, SPECIAL

COK

Page 1 of 1

1/18/2023

- a. **Description:** Work for the item of Removing Curb and Gutter - Special shall consist of the removal of the existing variable width curb and gutter to a neat clean line to facilitate the placement of new concrete curb and gutter.
- b. **Construction Methods:** The existing pavement shall be saw cut full depth at a distance of one (1) foot from the existing edge of pavement prior to the removal of the existing curb and gutter. Once the pavement has been cut, the existing curb and gutter and adjacent one (1) foot of pavement will be removed. Care will be taken not to disturb the pavement that is to remain in place.

Removed section of roadway shall be restored per City standard detail following placement of new curb & gutter. Replace pavement adjacent to the new Curb and Gutter and use 6-inch Nonreinforced Concrete Base Course for the base. Roadway should be restored with the proper lifts of HMA on top of the concrete base according to the COK Standard Details.

- c. **Measurement and Payment:** Removing Curb and Gutter - Special shall be paid at the unit cost per lineal foot. Measurement will be made along the edge of pavement prior to removal. All work involved including saw cutting, removal and disposal shall be included in the unit price.

<u>Pay Item</u>	<u>Unit</u>
Curb and Gutter, Rem, Special	Foot
Conc Base Cse, Nonreinf, 6-inch	Syd
Hand Patching, HMA	Ton

CITY OF KALAMAZOO

SPECIAL PROVISION

FOR

SURFACE RESTORATION

COK

Page 1 of 2

8/13/2025

a. Description. This work shall be done in accordance with the City of Kalamazoo Standards. The requirements of the special provision include a one-year warranty period from date of final inspection performed by the City of Kalamazoo or its designated representative.

b. Materials. The materials and application rates specified in Sections 816 and 917 of the Michigan Department of Transportation Standard Specifications for Construction apply unless modified by this special provision or otherwise directed by the Engineer.

Materials included in Surface Restoration:

1. Topsoil Surface, Furn, 3 inch
2. Fertilizer, Chemical Nutrient, Cl A (12-12-12)
3. Seeding, Mixture THM
4. Paper mulch shall be used for hydroseeding
5. Mulch Blanket
6. Water, Sodding/Seeding/Hydroseeding
7. Tackifier shall be MDOT approved from the QPL
8. The hydro-seeding slurry shall consist of a mixture of the following materials:
 - Mulch: 2,000lbs./acre
 - Fertilizer: 400lbs./acre
 - Tackifier: 25lbs./acre
 - Seed: 220lbs./acre
 - Water: As required

c. Construction Methods. Prior to placing topsoil, shape and compact all areas to be seeded and hydroseeded. Place topsoil to the minimum depth indicated above, to meet proposed finished grade. If the area being restored requires more than the minimum depth of topsoil to meet finished grade, this additional depth may be filled with approved excavated material. Furnishing and placing this additional material is included in Station Grading road sections or is incidental in patching sections.

In areas of hydroseeding, the Contractor shall protect site features from over spray. These features shall include, but not be limited to, fire hydrants, mailboxes (including posts), private properties, sidewalks, driveways, pavements or other surfaces that the Engineer may designate as needing to be protected from the hydroseeding operation. Where directed by the Engineer, the Contractor will be responsible to remove all unwanted or unintended overspray. The cost for this work will be the sole responsibility of the Contractor.

Areas within existing and proposed drainage channels shall be restored using mulch blankets with appropriate anchors as recommended by the manufacturer. All other areas shall be restored using mulch. Mulch shall be bladed into the prepared earth to provide proper anchoring.

If a restored area washes out after this work has been properly completed and approved by the Engineer, make the required corrections to prevent future washouts and replace the topsoil, fertilizer, seed and mulch. This replacement shall be paid for as additional work. If an area washes out for reasons attributable to the Contractor's activity or failure to take proper precautions, replacement shall be at the Contractor's expense.

All areas disturbed by the Contractor and/or their Subcontractors beyond the normal construction limits of this project shall be restored as directed by the Engineer. No additional payment or compensation will be allowed for this activity.

By October 15, only those areas for which work for Surface Restoration has already begun shall be completed. After October 15, any remaining areas shall be graded and covered by mulch blanket, temporary seeding and restored the following April 15, or as soon as weather permits.

The Contractor shall establish a dense lawn of permanent grasses, free from lumps and depressions or any bare spots, none of which is larger than one foot of area up to a maximum of 3% of the total seeded lawn area. Any part of the seeded lawn that fails to show a uniform germination shall be reseeded until a dense grass cover is established.

Repair, rework, re-seed all areas that have washed out, are eroded, or do not catch.

d. Measurement and Payment. The completed work, as described, will be measured and paid for at the contract unit price using the following pay item:

<u>Contract Item (Pay Item)</u>	<u>Pay Unit</u>
Surface Restoration, Modified.....	SYD

Surface Restoration will be measured in place. Payment for Surface Restoration shall include all materials, equipment, and labor required to complete the work as described.

CITY OF KALAMAZOO

SPECIAL PROVISION

FOR

UTILITY COORDINATION

COK

Page 1 of 2

1/18/2023

The Contractor shall cooperate and coordinate construction activities with the owners of utilities as stated in section 104.08 of the MDOT Standard Specifications for Construction. In addition, for the protection of underground utilities, the Contractor shall follow the requirements in Section 107.12 of the MDOT Standard Specifications for Construction. Contractor delay claims resulting from a utility, will be determined based upon Section 109.05 of the MDOT Standard Specifications for Construction.

For protection of underground utilities in conformance with Public Act 53, the Contractor shall dial 1-800-482-7171 or 811 a minimum of three (3) full working days, excluding Saturdays, Sundays and holidays, prior to beginning each excavation in areas where public utilities have not been previously located. Members will thus be routinely notified. This does not relieve the Contractor of the responsibility of notifying utility owners who may not be a part of the "MISS dig" alert system.

PUBLIC UTILITIES

The following Public Utilities have facilities located within the Right-of-Way:

Name of Owner	Kind of Utility
Consumers Energy 2500 East Cork Street Kalamazoo, MI 49001	Electric Natural Gas
AT&T 2919 Millcork Street Kalamazoo, MI 49001	Telephone
Charter Communications 4176 Commercial Avenue Portage MI 49002	Cable
Comcast 5047 W Main Street Kalamazoo, MI 49009	Cable
CTS Telecom 13800 East Michigan Avenue Galesburg, MI 49053	Fiber
Midwest Fiber 6070 North Flint Road Glendale, WI 53209	Fiber

Western Michigan University
1903 W. Michigan Avenue
Kalamazoo, MI 49008

University

City of Kalamazoo
Public Utilities Department
415 Stockbridge Avenue
Kalamazoo, MI 49001

Water
Sanitary Sewer
Storm Sewer
City Fiber