



Department of Management Services
Purchasing Division
241 West South Street
Kalamazoo, MI 49007-4796
Phone: 269.337.8020
www.kalamazoocity.org
purchasing@kalamazoocity.org

INVITATION FOR BIDS (IFB)

The City of Kalamazoo, Michigan is soliciting sealed bids for:

PROJECT NAME: Thermostatic Mixing Valves

BID REFERENCE #: 94191-001.0

IFB ISSUE DATE: December 16, 2025

BID DUE/OPENING DATE: January 6, 2026 @ 3:30 p.m. Local Time
Electronic Bids Will Not Be Accepted.

MAILING ADDRESS & INSTRUCTIONS

Mail to:
Purchasing Division
241 W. South Street
Kalamazoo, MI 49007

Questions about this IFB should be directed to:
Department Contact: **Anna Crandall, Assistant City Engineer** at crandalla@kalamazoocity.org

Include on the Envelope the Project Name and Bid Reference Number. All Envelopes Must Be Sealed.

You are invited to submit a bid for this project. Specifications, terms, conditions and instructions for submitting bids are contained herein. This Invitation for Bid with all pages, documents and attachments contained herein, or subsequently added to and made a part hereof, submitted as a fully and properly executed bid shall constitute the contract between the City and the successful bidder when approved and accepted on behalf of the City by an authorized official or agent of the City. Please review the bid document as soon as possible and note the **DEADLINE FOR QUESTIONS** in the Instructions to Bidders.

All bidders shall complete and return the Bid and Award page(s) and submit all information requested herein in order for a bid to be responsive. The bid document shall be returned in its entirety, in a properly identified and sealed envelope to the Purchasing Division at the above address. **BIDS MUST BE RECEIVED BEFORE THE DUE DATE - LATE BIDS WILL NOT BE CONSIDERED.** The City reserves the right to postpone the bid opening for its own convenience.

TABLE OF CONTENTS

<u>SECTION</u>		<u>PAGE #</u>	<u>APPENDICES</u>
	Statement of No Bid		
I	Instructions to Bidders	1 - 2	Appendix A
II	Bid & Award Pages	3 - 7	Specifications
III	Indemnity & Insurance	8 - 9	
IV	Specifications	10 - 12	
V	Terms & Conditions	13 - 16	

STATEMENT OF NO BID

NOTE: If you DO NOT intend to bid on this commodity or service, please complete and return this form immediately. Your response will assist us in evaluating all responses for this important project and to improve our bid solicitation process.

The Purchasing Division of the City of Kalamazoo wishes to keep its bidders list file up-to-date. If, for any reason you cannot supply the commodity/service noted in this bid solicitation, this form must be completed and returned to remain on the particular bid list for future projects of this type.

If you do not respond to this inquiry within the time set for the bid opening date and time noted, we will assume that you can no longer supply this commodity/service, and your name will be removed from this bid list.

- _____ Specifications too "tight", i.e. geared toward one brand or manufacturer only (explain below).
- _____ Specifications are unclear (explain below).
- _____ We are unable to meet specifications.
- _____ Insufficient time to respond to the Invitation for Bid.
- _____ Our schedule would not permit us to perform.
- _____ We are unable to meet bond requirements.
- _____ We are unable to meet insurance requirements.
- _____ We do not offer this product or service.
- _____ Remove us from your bidders list for this commodity or service.
- _____ Other (specify below).

REMARKS: _____

SIGNED: _____ NAME: _____
(Type or Print)

TITLE: _____ DATE: _____

FIRMNAME: _____
(if any)

ADDRESS: _____
(Street address) (City) (State) (Zip)

PHONE: _____ EMAIL: _____

**SECTION I
INSTRUCTIONS TO BIDDERS**

1. **EXAMINATION OF BID DOCUMENT**-Before submitting a bid, bidders shall carefully examine the specifications and shall fully inform themselves as to all existing conditions and limitations. The bidder shall indicate in the bid the sum to cover the cost of all items included on the bid form.
2. **PREPARATION OF BID**-The bid shall be legibly prepared in ink or typed. If a unit price or extension already entered by the bidder on the Bid and Award form is to be altered, it shall be crossed out and the new unit price or extension entered above or below and initialed by the bidder with ink. The bid shall be legally signed and the complete address of the bidder given thereon.

All bids shall be tightly sealed in an envelope plainly marked SEALED BID and identified by project name, bid opening date and time. Bids opened by mistake, due to improper identification, will be so documented and resealed. The Purchasing Division will maintain and guarantee confidentiality of the contents until the specified opening date and time. Bids submitted electronically will not be accepted.

3. **EXPLANATION TO BIDDERS**-Any binding explanation desired by a bidder regarding the meaning or interpretation of the Invitation for Bids (IFB) and attachments must be requested in writing, **at least 5 business days before the bid opening** so a reply may reach all prospective bidders prior to the submission of bids. Any information given to a prospective bidder concerning the IFB will be furnished to all prospective bidders as an amendment or addendum to the IFB if such information would be prejudicial to uninformed bidders. Receipt of amendments or addenda by a bidder must be acknowledged in the bid by attachment, or by letter received before the time set for opening of bids. Oral explanation or instructions given prior to the opening will not be binding.
4. **CASH DISCOUNTS**-Discount offered for payment of less than thirty (30) days will not be considered in evaluating bids for award. Offered discounts of less than thirty (30) days will be taken if payment is made within the discount period, even though not considered in evaluation of the bid.
5. **WITHDRAWAL OF BIDS**-Bids may be withdrawn in person by a bidder or authorized representative, provided their identity is made known and a receipt is signed for the bid, but only if the withdrawal is made prior to the exact time set for receipt of bid. No bid may be withdrawn for at least ninety (90) days after bid opening.
6. **ALTERNATE BIDS**-bidders are cautioned that any alternate bid, unless specifically requested or any changes, insertions or omissions to the terms and conditions, specifications or any other requirement of this IFB may be considered non-responsive, and at the option of the City, result in rejection of the alternate bid.
7. **LATE BIDS**-Any bid received at the office designated herein after the exact time specified for receipt will not be considered. (Note: The City reserves the right to consider bids that have been determined by the City to be received late due to mishandling by the City after receipt of the bid and no award has been made.)
8. **UNIT PRICES**-If there is a discrepancy between unit prices and their extension, unit prices shall prevail.
9. **BID SUBMITTAL**- Bidders can submit sealed bids in one of the following ways:
 - 9.1. **Mail your bid**, to be received before the bid due date and time indicated in the bid document, to the City of Kalamazoo at the following address:

City of Kalamazoo
Purchasing Division
241 West South Street
Kalamazoo, MI 49007

- 9.2. **Deliver your bid to City Hall In-Person** before the bid due date and time indicated in the bid document.
- 9.3. **Deliver your bid to the Treasurer’s Office Payment Drop Box** located in the northwest corner of City Hall (see photos below) before the bid due date and time indicated in the bid document.



1. Open drop box located at City Hall.



2. Insert SEALED BID here.



- 10. **BID TABULATIONS-** The Purchasing Division makes an effort to post bid tabulations to the City of Kalamazoo website within 24 hours after the bid opening date and time at: <https://www.kalamazoocity.org/bidopportunities>. However, in certain cases the posting of the bid tabulation may extend beyond the 24-hour window.

SECTION II
BID AND AWARD

The undersigned having become thoroughly familiar with all of the bid/contract documents incorporated herein, the project site and the location conditions affecting the work, hereby proposes to perform everything required to be performed in strict conformity with the requirements of these documents, and to provide and furnish all the equipment, labor and materials necessary to complete in a professional manner the furnishing and installing of all of the following, meeting or exceeding the specifications as set forth herein for the prices as stated below.

Thermostatic Mixing Valves

Item	Description	Unit	Qty	Unit Price	Extended Price
1	Thermostatic Mixing Valve, Caleffi #521518A, 3/4" PEX expansion connections with integral outlet temperature gauge.	EA	265		
TOTAL BID AMOUNT				\$	

Delivery costs shall be included in the quoted material unit pricing.

Guarantee delivery within _____ calendar days after receipt of Notice to Proceed.

All materials used in connection with drinking water shall be NSF certified.

Bidder shall provide all of the information as requested herein with their bid. **Failure to do so and/or failure to provide post-bid requested information may be cause for rejecting the bid as non-responsive.**

Bidder/Supplier has examined and carefully studied the bidding documents and attachments, and acknowledges receipt of the following addenda:

Addendum No: _____

Dated: _____

By my signature below, I certify that the firm bidding on this contract, when making hiring decisions, does not use a past criminal conviction as a bar to or preclude a person with a criminal conviction from being considered for employment with the bidding firm unless otherwise precluded by federal or state law. I further certify that I have read and agree to be bound by the provisions of the City’s Non-Discrimination Clause found in Appendix A as updated by City Ordinance 1856.

Signed: _____ Name: _____

Title: _____

CITY OF KALAMAZOO
LOCAL PREFERENCE POLICY AND CERTIFICATION

The lowest responsive Kalamazoo County bidder whose bid is not low but falls within 2% of the lowest responsive bid is afforded the opportunity to become the successful bidder if it agrees to reduce its bid to match the lowest responsive bid. The City of Kalamazoo is the sole determiner whether a bidder is responsible, qualifies as a Kalamazoo County bidder, and if its bid is responsive to the City's specifications, terms, and conditions.

If the lowest Kalamazoo County bidder chooses not to match the lowest bid, the next lowest responsive Kalamazoo County bidder whose bid falls within 2% of the lowest bid is given the opportunity to match the lowest responsive bid.

To qualify as a Kalamazoo County bidder, the bidder must meet both the following criteria:

1. Have a physical presence in Kalamazoo County by maintaining a permanent office, factory, or other facility in Kalamazoo County with employees working in Kalamazoo County.
2. Have paid real or personal property taxes related to said business to the City of Kalamazoo, County of Kalamazoo, or other municipal corporation within Kalamazoo County in the previous tax year, except that a non-profit entity need not meet this requirement.

This local preference policy applies only to purchases for materials, supplies, capital outlay, and services for maintenance, repair or operation of City facilities that are over \$25,000. If more than 50% of the contract is sub-contracted to firms located outside of Kalamazoo County that bid does not qualify for the local preference policy outlined above. The local preference policy will not apply if prohibited by law. The Purchasing Agent has the authority to finally determine if the bidder qualifies as a Kalamazoo County bidder as set forth herein. The Purchasing Agent may take into account the permanency of the business in Kalamazoo, and whether the business appears to be claiming to be a Kalamazoo County business solely or primarily to qualify as a Kalamazoo County business under this Resolution, and any other material factors.

CERTIFICATION

If you qualify as a Kalamazoo County bidder and wish to be considered for the local preference provisions as provided above, please certify that fact by providing the information requested below and attesting to its accuracy.

Firm Name: _____

Street Address of Business: _____

City, State, and Zip Code: _____

Number of employees working in Kalamazoo County: _____

Name the city or township to which business real and/or personal property taxes are paid or provide non-profit status: _____

The above information is accurate:

Signature: _____ Date: _____

Title: _____

REFERENCE QUESTIONNAIRE

Please answer the following questions completely.

1. Firm name: _____
2. Established: Year _____ Number of Employees: _____
3. Type of organization:
 - a. Individual: _____
 - b. Partnership: _____
 - c. Corporation: _____
 - d. Other: _____
4. Former firm name(s) if any, and year(s) in business:

5. Include at least 3 references of contracts for similar work performed over the last five (5) years. Include: owner, contact person and phone number and description of work performed.
 - 5.1 Company Name: _____
Address: _____
Phone: _____
Contact: _____
Type of work or contract: _____
 - 5.2 Company Name: _____
Address: _____
Phone: _____
Contact: _____
Type of work or contract: _____
 - 5.3 Company Name: _____
Address: _____
Phone: _____
Contact: _____
Type of work or contract: _____

I hereby certify that all of the information provided is true and answered to the best of my ability.

Signed: _____ Name: _____
(type or print)

Title: _____ Date: _____

CITY OF KALAMAZOO EX-OFFENDER POLICY CHECKLIST

As part of the City's commitment to reducing unacceptable poverty, encouraging rehabilitation, reducing recidivism, and strengthening families in Kalamazoo, the City has updated its Purchasing Policy to ensure that firms with whom the City does business share in this commitment by utilizing hiring practices that do not unfairly deny people with arrest and conviction records gainful employment. *(Important: This requirement also extends to any subcontractors the bidder intends to use to fulfill the contract for goods or services being sought from the City.)*

Part I: Proof that the bidder does not inquire about an individual's past arrest or criminal history on the bidder's employment application form

- Attach a copy of the current application for employment being used by the bidder

Part II: Certification that the bidder does not use an individual's past arrest or criminal history to unlawfully discriminate against them by checking *one or more* of the following:

- That pursuant to federal or state law bidder is precluded from hiring persons with certain criminal records from holding particular positions or engaging in certain occupations by providing a cite to the applicable statute or regulation; if checking this box, provide a citation to the applicable statute or rule upon which the bidder is relying: _____
- That bidder conducts criminal history background checks only as necessary, and only after making a conditional offer of employment; that any withdrawal of an offer of employment to an individual because of a past criminal history is job-related and consistent with business necessity after the individual has been provided an individualized assessment opportunity to review and challenge or supplement the history of past criminal conduct being relied upon by the bidder;
- That the use by bidder of criminal history background checks complies with the U.S. Equal Employment Opportunity Commission's Enforcement Guidance on the Consideration of Arrest and Conviction Records in Employment Decisions and that the bidder has not had a determination rendered against it in the past 7 years that it discriminated against a person through the use of an individual's arrest or criminal history.

I CERTIFY THAT THE ABOVE STATEMENTS ARE TRUE.

Date

Signature

Printed Name

Position

I hereby state that all the information I have provided is true, accurate and complete. I hereby state that I have the authority to submit this bid which will become a binding contract if accepted by the City of Kalamazoo. I hereby state that I have not communicated with nor otherwise colluded with any other bidder, nor have I made any agreement with nor offered/accepted anything of value to/from an official or employee of the City of Kalamazoo that would tend to destroy or hinder free competition.

The firm's identification information provided will be used by the City for purchase orders, payment, and other contractual purposes. If the contractual relationship is with, or the payment made to, another firm please provide a complete explanation on your letterhead and attach to your bid. Please provide for accounts payable purposes:

Tax Identification Number (Federal ID): _____

Remittance Address: _____

Financial Contact Name: _____ Financial Contact Phone Number: _____

Financial Contact Email Address: _____

I hereby state that I have read, understand, and agree to be bound by all terms and conditions of this bid document.

SIGNED: _____ NAME: _____
(Type or Print)

TITLE: _____ DATE: _____

FIRM NAME: _____
(If any)

ADDRESS: _____
(Street address) (City) (State) (Zip)

PHONE: _____ EMAIL: _____

FOR CITY USE ONLY - DO NOT WRITE BELOW

**SECTION III
INDEMNITY AND INSURANCE**

Contractor, or any of their subcontractors, shall not commence work under this contract until they have obtained the insurance required under this paragraph, and shall keep such insurance in force during the entire life of this contract. All coverage shall be with insurance companies licensed and admitted to do business in the State of Michigan and acceptable to the City of Kalamazoo within ten (10) days of the Notice of Award. The requirements below should not be interpreted to limit the liability of the Contractor. All deductibles and SIR's are the responsibility of the Contractor.

The Contractor shall procure and maintain the following insurance coverage:

Workers' Compensation Insurance including Employers' Liability Coverage, in accordance with all applicable statutes of the State of Michigan.

Commercial General Liability Insurance on an "Occurrence Basis" with limits of liability not less than \$1,000,000 per occurrence and aggregate. Coverage shall include the following extensions: (A) Contractual Liability; (B) Products and Completed Operations; (C) Independent Contractors Coverage; (D) Broad Form General Liability Extensions or equivalent, if not already included and (E) XCU coverage if the nature of the contract requires XC or U work.

Automobile Liability in accordance with all applicable statutes of the State of Michigan, with limits of liability not less than \$1,000,000 per occurrence, combined single limit for Bodily Injury, and Property Damage. Coverage shall include all owned vehicles, all non-owned vehicles, and all hired vehicles.

Additional Insured: Commercial General Liability and Automobile Liability, as described above, shall include an endorsement stating that the following shall be *Additional Insureds*: The City of Kalamazoo, all elected and appointed officials, all employees and volunteers, all boards, commissions, and/or authorities and board members, including employees and volunteers thereof. It is understood and agreed that by naming the City of Kalamazoo as additional insured, coverage afforded is considered to be primary and any other insurance the City of Kalamazoo may have in effect shall be considered secondary and/or excess.

To the fullest extent permitted by law the Contractor agrees to defend, pay on behalf of, indemnify, and hold harmless the City of Kalamazoo, its elected and appointed officials, employees, agents and volunteers, and others working on behalf of the City of Kalamazoo against any and all claims, demands, suits, or loss, including all costs connected therewith, and for any damages which may be asserted, claimed, or recovered against or from the City of Kalamazoo, by reason of personal injury, including bodily injury or death and/or property damage, including loss of use thereof, which arises out of, or is in any way connected or associated with this contract.

Cancellation Notice: All policies, as described above, shall include an endorsement stating that it is understood and agreed that thirty (30) days, or ten (10) days for non-payment of premium, Advance Written Notice of Cancellation, Non-Renewal, Reduction, and/or Material Change shall be sent to: City of Kalamazoo, Purchasing Division, 241 W. South Street, Kalamazoo, MI 49007.

Proof of Insurance Coverage: The Contractor shall provide the City of Kalamazoo at the time that the contracts are returned by him/her for execution, or within 10 days of Notice of Award, whichever is earlier, a Certificate of Insurance as well as the required endorsements. In lieu of required endorsements, if applicable, a copy of the policy sections where coverage is provided for additional insured and cancellation notice would be acceptable. Copies or certified copies of all policies mentioned above shall be furnished, if so requested.

INDEMNITY AND INSURANCE

Continued

If any of the above coverages expire during the term of this contract, the Contractor shall deliver renewal certificates and/or policies to City of Kalamazoo at least ten (10) days prior to the expiration date.

Scope of Coverage: The above requirements and conditions shall not be interpreted to limit the liability of the Contractor under this Contract, but shall be interpreted to provide the greatest benefit to the City and its officers and employees. The above listed coverages shall protect the Contractor, its employees, agents, representatives and subcontractors against claims arising out of the work performed. It shall be the Contractor's responsibility to provide similar insurance for each subcontractor or to provide evidence that each subcontractor carries such insurance in like amount prior to the time such subcontractor proceeds to perform under the contract.

**SECTION IV
SPECIFICATIONS**

1. INTENT AND SCOPE OF SERVICE

It is the intent of the specifications to secure for the City of Kalamazoo the materials which will be most suitable for its type of operation and operating conditions.

2. MATERIAL SPECIFICATIONS

All materials shall be in accordance to the current edition of the City of Kalamazoo Standard Specifications and these bid documents.

3. QUANTITIES

The listed quantities are what is intended to be purchased. Payment will be based on unit pricing of quantity supplied.

4. AWARD CRITERIA

The purpose of establishing this contract is to provide a convenient method for the Water Division in obtaining their requirements and create a savings for Public Services by eliminating hundreds of purchase orders issued annually. The City reserves the right to split award by groups or award on an aggregate basis all items to one vendor whichever is in the best interest of the City.

5. SHIPPING NOTICES

Shipping notices should be mailed to the Water Division. Advance notification of shipments shall be made by telephone between 7am-3pm to Water Supply at (269) 337-8179, at least twenty-four (24) hours in advance of expected arrival. In no event shall materials ship prior to the notice to proceed.

6. ORDER RELEASE AND DELIVERY

6.1 All material shall be stored by the Supplier until order release is made by the City. The Supplier shall make deliveries on an "as required order release basis". Ordering of materials may be placed verbally by telephone or vendor visitation initiated by the Project Engineer or Stockroom personnel only.

6.2 Deliveries shall be made F.O.B. Destination delivered to the Department of Public Services, Water Division, 415 East Stockbridge Avenue, Kalamazoo, MI 49001.

6.3 **Once material has been released; the delivery period shall be within forty-eight (48) hours thereafter. If at any time a delivery cannot be made within the established time frame or an agreeable extension thereto, the Water Division may purchase their material needs from another source.**

7. **QUALITY**

- 7.1 The quality of standard components, manufacturing techniques, assembly procedures and service capabilities will be considered in the analysis of the bids.
- 7.2 The Supplier shall assume full responsibility for all materials, quality and workmanship whether of his/her manufacture or by others. Materials found to be defective shall be replaced by the Supplier at no cost to the City.
- 7.3 This contract shall be terminated by written notice from the City at any time the quality of materials provided falls below that as specified herein.

8. **DETAILED DESCRIPTION**

A detailed description of the manufacturer's standard product by means of literature or manuals shall be provided upon contract award or upon request.

9. **INVOICING**

Upon delivery the vendor shall leave an itemized copy of the packing slip with the using agency and obtain signature of proof of delivery. The vendor shall submit a monthly invoice in duplicate listing detail of items and cost.

All original invoice(s) will be sent to the Budget and Accounting Division, 241 W. South Street, Kalamazoo, MI 49007 or via email at apinvoice@kalamazoo.org. Faxed copy of invoice(s) will not be accepted, unless it is to replace an original invoice that was lost in the mail. The Budget and Accounting Division processes payments after receipt of an original invoice from the Supplier and approval by the department.

The City of Kalamazoo policy is to pay invoice(s) within 30 days from the receipt of the original invoice, if the services or supplies are satisfactory and the proper paperwork and procedures have been followed. In order to guarantee payment to the vendor on a timely basis, the vendor needs to receive a purchase order number before supplying the City of Kalamazoo with goods or services. All original, and copies of original invoice(s), will clearly state which purchase order they are being billed against.

The City of Kalamazoo is a government municipality and therefore is tax exempt from all sales tax. Our tax-exempt number is 38-6004627.

The vendor is responsible for supplying the Budget and Account Division with a copy of their W-9 if they are providing a service to the City of Kalamazoo.

10. **RETURN ITEMS**

Items may be returned for restocking in Supplier's inventories. Common items not deemed as specialty items will not be subject to restocking fees if returned within 30 days. All items returned must be returned in reusable condition subject to Supplier's rejection upon return. Any specialty items ordered and returned after 30 days will be subject to a restocking fee.

11. **PACKAGING**

All items shall use appropriate packaging standards.

12. **PRIOR APPROVAL**

Items bid may require prior approval from City Engineering Staff and other user groups within the Department of Public Services. The City reserves the right to identify items requiring approval prior to award.

13. QUESTIONS

Questions relative to the bid specifications can be addressed to Anna Crandall, Public crandalla@kalamazoo-city.org by 10 am on December 30, 2025. Questions relative to the general bid requirements may be addressed to Kyle Dunn, Buyer at (269) 337-8720 or dunnk@kalamazoo-city.org. This does not relieve bidders of Item 3, Page 1 of the bid document.

SECTION V
TERMS AND CONDITIONS

1. AWARD OF CONTRACT

1.1 This contract will be awarded to that responsible bidder whose bid, conforming to this solicitation, will be most advantageous to the City, price and other factors considered. The City reserves the right to accept or reject any or all bids and waive informalities and minor irregularities in bids received. Other factors include, as an example but not limited to, delivery time, conformance to specifications, incidental costs such as demurrage and deposits, etc.

Notification of award will be in writing by the Purchasing Agent. Upon notification, the Contractor shall submit to the Purchasing Division all required insurance certificates (if required) and such other documentation as may be requested or required hereunder. Upon their receipt and subsequent approval by the City, the Purchasing Agent will forward to the Contractor a written **NOTICE TO PROCEED**. Work shall **NOT** be started until such **NOTICE TO PROCEED** is received by the Contractor.

1.2 Unilateral changes in bid prices by the bidder shall not be allowed. However, the City, at its sole option, reserves the right to negotiate with bidders in the event of, but not limited to:

- 1.2.1 No bids received;
- 1.2.2 A single bid being received; or
- 1.2.3 Prices quoted or bid are over budget and/or unreasonable.

2. COMPLETE CONTRACT

This bid document together with its addenda, amendments, attachments, and modifications, when executed, becomes the complete contract between the parties hereto, and no verbal or oral promises or representations made in conjunction with the negotiation of this contract shall be binding on either party.

3. SUBCONTRACTORS - NON-ASSIGNMENT

Bidders shall state in writing any and all sub-contractors to be associated with this bid, including the type of work to be performed. The Contractor shall cooperate with the City of Kalamazoo in meeting its commitments and goals with regard to maximum utilization of minority and women-owned business enterprises.

The Contractor hereby agrees and understands that the contract resulting from this solicitation shall not be transferred, assigned, or sublet without prior written consent of the City of Kalamazoo.

4. TAXES

The City of Kalamazoo is exempt from all federal excise tax and state sales and use taxes.

5. INVOICING

All original invoice(s) will be sent to the Financial Services Division, 241 W. South Street, Kalamazoo, MI 49007 or via email at apinvoice@kalamazoo.org. The Finance Division processes payments after receipt of an original invoice from the Contractor and approval by the department. The City of Kalamazoo's policy is to pay invoice(s) within 30 days from the receipt of the original invoice, if the services or supplies are satisfactory and the proper paperwork and procedures have been followed. **In order to guarantee payment to the vendor on a timely basis, the vendor needs to receive a purchase order number before supplying the City of Kalamazoo with goods or services.** All original, and copies of original invoice(s), will clearly state which purchase order they are being billed against.

The City of Kalamazoo is a government municipality and therefore is tax exempt from all sales tax.

The vendor is responsible for supplying the Finance Division with a copy of their W9 if they are providing a service to the City of Kalamazoo.

6. PAYMENTS

Unless otherwise specified by the City in this contract, the Contractor will be paid in not more than thirty (30) days after receipt of a properly executed invoice, the sum stipulated herein for supplies delivered and accepted, or service rendered and accepted. Payments are processed by the Management Services Financial Services Division after receipt of an original invoice from the Contractor and approval by the department.

7. CHANGES AND/OR CONTRACT MODIFICATIONS

The City reserves the right to increase or decrease quantities, service or requirements, or make any changes necessary at any time during the term of this contract, or any negotiated extension thereof. Price adjustments due to any of the foregoing changes shall be negotiated and mutually agreed upon by the Contractor and the City.

Changes of any nature after contract award which reflect an increase or decrease in requirements or costs shall not be permitted without prior approval by the Purchasing Agent. City Commission approval may also be required.

ANY CHANGES PERFORMED IN ADVANCE OF PURCHASING AGENT APPROVAL MAY BE SUBJECT TO DENIAL AND NON-PAYMENT.

8. LAWS, ORDINANCES AND REGULATIONS

The Contractor shall keep himself/herself fully informed of all local, state, and federal laws, ordinances and regulations in any manner affecting those engaged or employed in the work and the equipment used. Contractor and/or employees shall, at all times, serve and comply with such laws, ordinances and regulations.

Any permits, licenses, certificates, or fees required for the performance of the work shall be obtained and paid for by the Contractor.

This contract shall be governed by the laws of the State of Michigan.

9. RIGHT TO AUDIT

The City or its designee shall be entitled to audit all the Contractor's records, and shall be allowed to interview any of the Contractor's employees, throughout the term of this contract and for a period of three years after final payment or longer if required by law to the extent necessary to adequately permit evaluation and verification of:

- A. Contractor compliance with contract requirements,
- B. Compliance with provisions for pricing change orders, invoices or claims submitted by the Contractor or any of his payees.

10. HOLD HARMLESS

If the negligent acts or omissions of the Contractor/Vendor or its employees, agents or officers, cause injury to person or property, the Contractor/Vendor shall indemnify and save harmless the City of Kalamazoo, its agents, officials, and employees against all claims, judgments, losses, damages, demands, and payments of any kind to persons or property to the extent occasioned from any claim or demand arising therefrom.

11. DEFAULT

The City may at any time, by written notice to the Contractor, terminate this contract and the Contractor's right to proceed with the work, for just cause, which shall include, but is not limited to the following:

- A. Failure to provide insurance and bonds (when called for), in the exact amounts and within the time specified or any extension thereof.

DEFAULT (Cont.)

- B. Failure to make delivery of the supplies, or to perform the services within the time specified herein, or any extension thereof.
- C. The unauthorized substitution of articles for those bid and specified.
- D. Failure to make progress if such failure endangers performance of the contract in accordance with its terms.
- E. Failure to perform in compliance with any provision of the contract.
- F. **Standard of Performance** - Contractor guarantees the performance of the commodities, goods or services rendered herein in accordance with the accepted standards of the industry or industries concerned herein, except that if this specification calls for higher standards, then such higher standards shall be provided.

Upon notice by the City of Contractor's failure to comply with such standards or to otherwise be in default of this contract in any manner following the Notice to Proceed, Contractor shall immediately remedy said defective performance in a manner acceptable to the City. Should Contractor fail to immediately correct said defective performance, said failure shall be considered a breach of this contract and grounds for termination of the same by the City.

In the event of any breach of this contract by Contractor, Contractor shall pay any cost to the City caused by said breach including but not limited to the replacement cost of such goods or services with another Contractor.

The City reserves the right to withhold any or all payments until any defects in performance have been satisfactorily corrected.

In the event the Contractor is in breach of this contract in any manner, and such breach has not been satisfactorily corrected, the City may bar the Contractor from being awarded any future City contracts.

- G. All remedies available to the City herein are cumulative and the election of one remedy by the City shall not be a waiver of any other remedy available to the City either listed in this contract or available by operation of law.

12. TERMINATION OF CONTRACT

The City may, at any time and without cause, suspend the work of this contract for a period of not more than ninety days after providing notice in writing to the Contractor. The Contractor shall be allowed an adjustment in the contract price or an extension of the contract times, or both, directly attributable to the suspension if Contractor makes an approved claim.

The City may, without prejudice to any other right or remedy of the City, and with or without cause, terminate the contract by giving seven days written notice to the Contractor. In such case the Contractor shall be paid, without duplication, for the following items:

- A. Completed and acceptable work executed in accordance with the contract documents prior to the effective date of termination, including fair and reasonable sums for overhead and profit on such work;
- B. Expenses sustained prior to the effective date of termination in performing services and furnishing labor, materials or equipment as required by the contract documents in connection with uncompleted work, plus fair and reasonable sums for overhead and profit on such expenses;
- C. All documented claims, costs, losses, and damages incurred in settlement of terminated contracts with Subcontractors, Suppliers, and others; and

TERMINATION OF CONTRACT (Cont.)

D. Reasonable expenses directly attributable to termination.

The Contractor shall not be paid on account of loss of anticipated profits or revenue or other economic loss arising out of or resulting from such termination.

13. INDEPENDENT CONTRACTOR

At all times, the Contractor, any of his/her employees, or his/her sub-contractors and their subsequent employees shall be considered independent contractors and not as City employees. The Contractor shall exercise all supervisory control and general control over all workers' duties, payment of wages to Contractor's employees and the right to hire, fire and discipline their employees and workers. As an independent contractor, payment under this contract shall not be subject to any withholding for tax, social security, or other purposes, nor shall the Contractor or his/her employees be entitled to sick leave, pension benefit, vacation, medical benefits, life insurance or workers' unemployment compensation or the like.

14. MEETINGS

The Contractor and/or Project Supervisor shall be available to meet with the Department Head or Project Manager at a mutually agreeable time to discuss problems, issues or concerns relative to the contract. Either party may call a meeting at any time. When such a request for a meeting is made, the meeting date shall, in no case exceed five (5) working days after the request; and, if in the sole opinion of the Department Head, the severity of the circumstance warrants, no more than one (1) working day.

15. INSPECTION OF WORK SITE

Before submitting bids or quotes for work, the Contractor shall be responsible for examining the work site and satisfying himself/herself as to the existing conditions under which he/she will be obligated to operate, or that in any way affects the work under this contract. No allowance shall be made subsequently, in behalf of the Contractor, for any negligence on his/her part.

16. CONTRACT PERIOD, EXTENSIONS, CANCELLATION

- A. The contract shall be in effect for the term stated in the specifications.
- B. The City may opt to extend this contract upon mutual agreement of both parties. The number of extensions shall be limited to that stated in the specifications.
- C. The City may, from time to time, find it necessary to continue this contract on a month-to-month basis only, not to exceed a six (6) month period. Such month-to-month extended periods shall be by mutual agreement of both parties, with all provisions of the original contract or any extension thereof remaining in full force and effect.
- D. All contracts, extensions and cost increases are subject to availability of funds and the approval of the City Commission (if required).
- E. The City reserves the right to cancel the contract due to non-appropriation of funds by the City with thirty (30) days written notice.
- F. Either party may terminate the contract (or any extension thereof) without cause at the end of any twelve (12) month term by giving written notice of such intent at least 60 days prior to the end of said twelve (12) month term.
- G. All notices are in effect commencing with the date of mailing. Written notices may be delivered in person or sent by First Class mail; emailed to the last known address.
- H. If cancellation is for default of contract due to non-performance, the contract may be canceled at any time (see Item 11, DEFAULT)

APPENDIX A
NON-DISCRIMINATION CLAUSE FOR ALL CITY OF KALAMAZOO CONTRACTS

The Contractor agrees to comply with the Federal Civil Rights Act of 1964 as amended; the Federal Civil Rights Act of 1991 as amended; the Americans With Disabilities Act of 1990 as amended; the Elliott-Larson Civil Rights Act, Act. No. 453, Public Act of 1976 as amended; the Michigan Handicappers Civil Rights Act, Act No. 220, Public Act of 1976 as amended, City Ordinance 1856 and all other applicable Federal and State laws. The Contractor agrees as follows:

1. The Contractor will not discriminate against any employee or applicant for employment because of race, color, religion, national origin, sex, age, height, weight, marital status, physical or mental disability, family status, sexual orientation or gender identity that is unrelated to the individual's ability to perform the duties of the particular job or position. Such action shall include, but not be limited to the following: employment, upgrading, demotion or transfer, recruitment advertising, layoff or termination; rates of pay or other forms of compensations; and selection for training, including apprenticeship.
2. The Contractor will, in all solicitations or advertisements for employees placed by or on behalf of the Contractor, state that all qualified applicants will receive consideration for employment without regard to race, color, religion, national origin, sex, age, height, weight, marital status, physical or mental disability family status, sexual orientation or gender identity that is unrelated to the individuals ability to perform the duties of the particular job or position.
3. If requested by the City, the Contractor shall furnish information regarding practices, policies and programs and employment statistics for the Contractor and subcontractors. The Contractor and subcontractors shall permit access to all books, records and accounts regarding employment practices by agents and representatives of the City duly charged with investigative duties to assure compliance with this clause.
4. Breach of the covenants herein may be regarded as a material breach of the contract or purchasing agreement as provided in the Elliott-Larsen Civil Rights Act and City Ordinance 1856.
5. The Contractor will include or incorporate by reference the provisions of the foregoing paragraphs 1 through 4 in every subcontract or purchase order unless exempted by the rules, regulations or orders of the Michigan Civil Rights Commission* and will provide in every subcontract or purchase order that said provision will be binding upon each subcontractor or seller.
6. The Contractor will not preclude a person with a criminal conviction from being considered for employment unless otherwise precluded by federal or state law. (for contracts over \$25,000)

The Elliott-Larson Civil Rights Act, Sec. 202 of Act. No. 453 of 1976 reads in part as follows:

Sec. 202. (1) An employer shall not:

- (a) Fail or refuse to hire, or recruit, or discharge or otherwise discriminate against an individual with respect to employment, compensation, or a term condition or privilege of employment because of religion, race, color, national origin, age, sex, height, weight or marital status.
- (b) Limit, segregate or classify an employee or applicant for employment in a way which deprives or tends to deprive the employee or applicant of an employment opportunity or otherwise adversely affects the status of an employee or applicant because of religion, race, color, national origin, age, sex, height, weight or marital status.
- (c) Segregate, classify or otherwise discriminate against a person on the basis of sex with respect to a term, condition or privilege of employment, including a benefit plan or system.

* Except for contracts entered into with parties employing less than three employees.



SPECIFICATIONS

Thermostatic Mixing Valves

Bid Reference #: 94191-001.0

December 2025



01050/23.1 NA

Replaces 01050/23 NA

MixCal™ Adjustable three-way thermostatic mixing valve

521 series



Function

The Caleffi MixCal™ 521 series three-way thermostatic mixing valve is used in systems producing domestic hot water or in hydronic and radiant heating systems. It maintains the desired output temperature of the mixed water supplied at a constant set value compensating for both temperature and pressure fluctuations of the incoming hot and cold water.

The MixCal thermostatic mixing valve is ICC-ES certified to ASSE 1017 and CSA B125.3. It complies with codes IPC, IRC, NPC and UPC for use in accordance with the US and Canadian plumbing codes, and standard NSF/ANSI/CAN 372, low lead.

Caleffi code 290030 full-port ball valve is designed for isolating the MixCal 521 series that has 1" metric "G" thread union connections. The isolation valve installs in between the valve body and the tailpiece fitting assembly. Male x Female configuration and bi-directional full ball valve flow capacity provides flexibility for using one or two isolation valves for the primary functioning valve. An optional stem extension is also available for those projects that require pipe insulation.

Product range

521__A series	Adjustable three-way thermostatic mixing valve with optional dual-scale outlet temperature gauge..... sizes ½", ¾", 1" with NPT male, sweat, press, PEX crimp and PEX expansion union
521__AC series	Adjustable three-way thermostatic mixing valve with inlet port check valves and optional dual-scale outlet temperature gauge sizes ½", ¾", 1" with NPT male, sweat, press, PEX crimp and PEX expansion union
521101A	Adjustable three-way thermostatic mixing valve, (replacement body)..... connections 1" male union thread with no fittings or union nuts

Technical specifications

Materials

- Body: low-lead brass (<0.25% Lead content)
- Shutter, seats and slide guides: PPO
- Springs: stainless steel
- Seals: peroxide-cured EPDM

Performance

Suitable fluids:	water, glycol solution
Max. percentage of glycol:	30%
Setting range:	85–150° F (30–65° C)
Tolerance:	±3° F (±2° C)
Max. working pressure (static):	200 psi (14 bar)
Max. operating differential pressure (dynamic):	75 psi (5 bar)
Max recommended differential pressure:	20 psi (1.5 bar)
Max. hot water inlet temperature:	200° F (93° C)
Max. inlet pressure ratio (H/C or C/H) for optimum performance:	2:1

Minimum temperature difference between hot water inlet and mixed water outlet for optimal performance:	27° F (15° C)
Minimum flow to ensure optimal performance:	1.0 gpm (3.8 L/min)
Minimum flow rate when recirculation flow rate is 1 gpm or greater:	0 gpm (0 L/min)
Outlet temperature gauge (optional):	2" diameter
	Dual-scale 30°F - 210°F and 0°C - 100°C

Certifications:

1. ASSE 1017/CSA B125.3, certified by ICC-ES, file PMG-1357.
2. NSF/ANSI/CAN 372-2011, Drinking Water System Components- Lead Content Reduction of Lead in Drinking Water Act, California Health and Safety Code 116875 S.3874, Reduction of Lead in Drinking Water Act, certified by ICC-ES, file PMG-1360.
3. PEX crimp fittings certified to ASTM F 1807.
4. PEX expansion fittings certified to ASTM F 1960.

Connections:

- NPT male union: ½", ¾", 1"
- sweat union: ½", ¾", 1"
- press union: ½", ¾", 1"
- PEX crimp union: ½", ¾", 1"
- **PEX expansion:** ½", **¾"**, 1"
- lay length-hot to cold inlet (press connections):

size ½ inch:	3 5/8"
size ¾ inch:	3 5/8"
size 1 inch:	4 1/8"
size 1" with check	7 1/4"

Dimensions

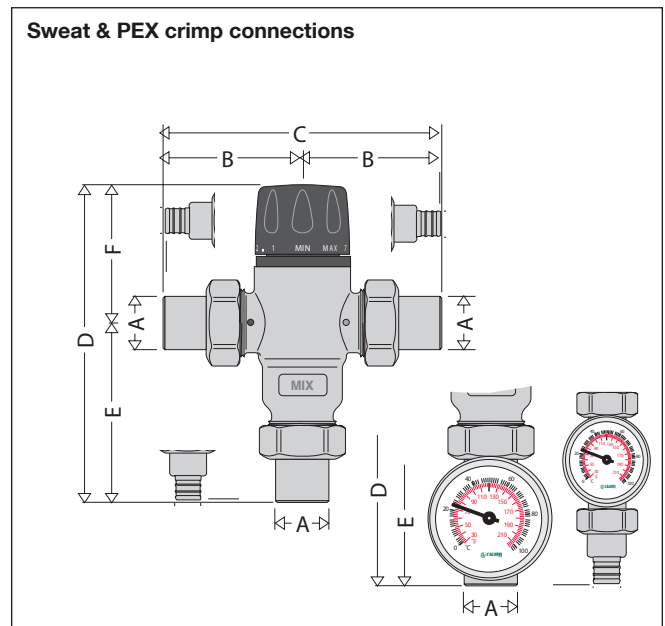
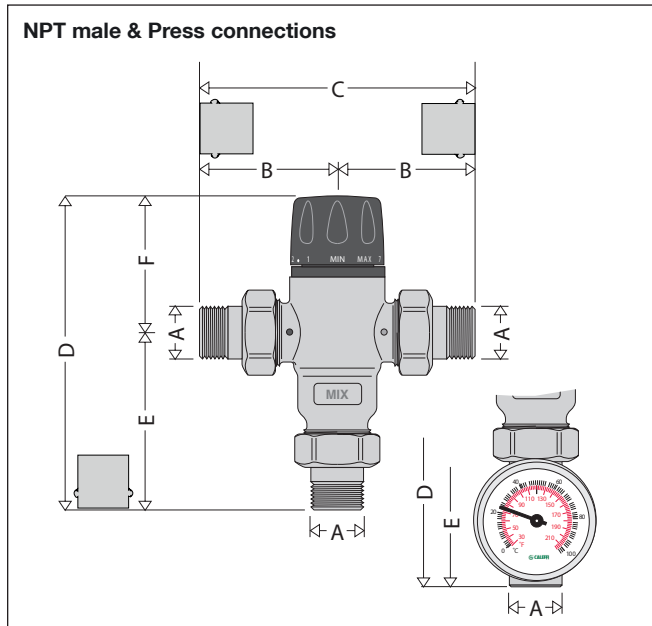

Code	A	B	C	D*	E	F	Wt. (lb.)
NPT Threaded connections							
521400A	1/2"	2 5/8"	5 1/4"	6"	3 3/8"	2 5/8"	2.4
521400AC	1/2"	2 5/8"	5 1/4"	6"	3 3/8"	2 5/8"	2.4
521410A**	1/2"	2 5/8"	5 1/4"	7 3/8"	4 3/4"	2 5/8"	2.9
521410AC**	1/2"	2 5/8"	5 1/4"	7 3/8"	4 3/4"	2 5/8"	2.9
521500A	3/4"	2 5/8"	5 1/4"	6"	3 3/8"	2 5/8"	2.4
521500AC	3/4"	3"	6"	6"	3 3/8"	2 5/8"	2.4
521510A**	3/4"	2 5/8"	5 1/4"	8"	5 3/8"	2 5/8"	2.9
521510AC**	3/4"	3"	6"	8"	5 3/8"	2 5/8"	2.9
521600A	1"	2 7/8"	5 3/4"	6 1/4"	3 3/4"	2 5/8"	2.4
521600AC	1"	3 1/16"	6 1/8"	6 1/4"	3 3/4"	2 5/8"	2.4
521610A**	1"	2 7/8"	5 3/4"	7 3/8"	5 1/8"	2 5/8"	2.9
521610AC**	1"	3 1/16"	6 1/8"	7 3/8"	5 1/8"	2 5/8"	2.9
Press connections							
521406A	1/2"	2 9/16"	5 1/8"	6"	3 3/8"	2 5/8"	2.4
521406AC	1/2"	3 3/16"	6 7/8"	6"	3 3/8"	2 5/8"	2.5
521416A**	1/2"	2 9/16"	5 1/8"	8 1/4"	5 5/8"	2 5/8"	2.9
521416AC**	1/2"	3 3/16"	6 7/8"	8 1/4"	5 5/8"	2 5/8"	3.0
521506A	3/4"	2 13/16"	5 5/8"	8 1/2"	5 7/8"	2 5/8"	2.4
521506AC	3/4"	4 3/16"	8 3/8"	8 1/2"	5 7/8"	2 5/8"	2.5
521516A**	3/4"	2 13/16"	5 5/8"	8 1/2"	5 7/8"	2 5/8"	2.9
521516AC**	3/4"	4 3/16"	8 3/8"	8 1/2"	5 7/8"	2 5/8"	3.0
521606A	1"	2 15/16"	5 7/8"	6 5/16"	3 11/16"	2 5/8"	2.6
521606AC	1"	4 5/16"	8 3/8"	6 5/16"	3 11/16"	2 5/8"	3.1
521616A**	1"	2 15/16"	5 7/8"	8 3/8"	6"	2 5/8"	3.1
521616AC**	1"	4 5/16"	8 3/8"	8 3/8"	6"	2 5/8"	3.5

C at the end of the code are models with integral inlet port check valves.

*At minimum temperature position on adjusting knob.

**Model with integral outlet temperature gauge.

Laylength (press):

sz 1/2" & 3/4" inch: 3 5/8"

sz 1" inch: 4 1/8"

sz 1" inch w/ checks: 7 1/4"

Code	A	B	C	D*	E	F	Wt. (lb.)
Sweat connections							
521409A	1/2"	2 1/4"	4 1/2"	5 5/8"	3 3/8"	2 5/8"	2.4
521419A**	1/2"	2 1/4"	4 1/2"	7"	4 1/2"	2 5/8"	2.9
521409AC	1/2"	2 7/8"	5 3/4"	5 5/8"	3 3/8"	2 5/8"	2.4
521419AC**	1/2"	2 7/8"	5 3/4"	7"	4 1/2"	2 5/8"	2.9
521509A	3/4"	2 1/2"	5"	5 13/16"	3 3/4"	2 5/8"	2.4
521519A**	3/4"	2 1/2"	5"	7 13/16"	5 1/4"	2 5/8"	2.9
521509AC	3/4"	3 1/16"	6 1/8"	5 13/16"	3 3/4"	2 5/8"	2.4
521519AC**	3/4"	3 1/16"	6 1/8"	7 13/16"	5 1/4"	2 5/8"	2.9
521609A	1"	3 1/16"	6 1/8"	6 7/16"	3 3/8"	2 5/8"	2.4
521619A**	1"	3 1/16"	6 1/8"	7 13/16"	5 1/4"	2 5/8"	2.9
521609AC	1"	3 1/4"	6 1/2"	6 7/16"	3 3/8"	2 5/8"	2.4
521619AC**	1"	3 1/4"	6 1/2"	7 13/16"	5 1/4"	2 5/8"	2.9
PEX crimp connections							
521407A	1/2"	3 1/4"	6 1/2"	6 1/2"	4"	2 5/8"	2.4
521417A**	1/2"	3 1/4"	6 1/2"	6 1/2"	4"	2 5/8"	2.5
521407AC	1/2"	3 1/4"	6 1/2"	6 1/2"	4"	2 5/8"	2.9
521417AC**	1/2"	3 1/4"	6 1/2"	8 3/4"	6 1/8"	2 5/8"	2.9
521507A	3/4"	3 1/4"	6 1/2"	6 1/2"	4"	2 5/8"	2.4
521517A**	3/4"	3 1/4"	6 1/2"	6 1/2"	4"	2 5/8"	2.5
521507AC	3/4"	3 1/4"	6 1/2"	6 1/2"	4"	2 5/8"	2.9
521517AC**	3/4"	3 1/4"	6 1/2"	8 3/4"	6 1/8"	2 5/8"	2.9
521607A	1"	3 1/4"	6 1/2"	6 1/2"	4"	2 5/8"	2.4
521617A**	1"	3 1/4"	6 1/2"	6 1/2"	4"	2 5/8"	2.5
521607AC	1"	3 1/4"	6 1/2"	6 1/2"	4"	2 5/8"	2.9
521617AC**	1"	3 1/4"	6 1/2"	8 3/4"	6 1/8"	2 5/8"	2.9

C at the end of the code are models with integral inlet port check valves.

*At minimum temperature position on adjusting knob.

**Model with integral outlet temperature gauge.

PEX expansion connections

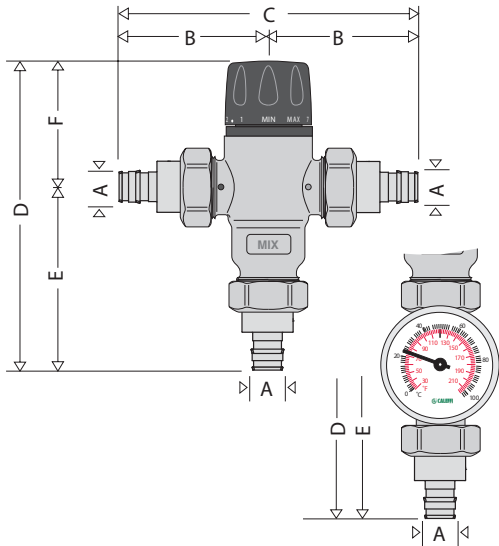

Code	A	B	C	D*	E	F	Wt. (lb)
521408A	1/2"	3 3/8"	6 3/4"	6 7/16"	3 13/16"	2 5/8"	2.4
521418A**	1/2"	3 3/8"	6 3/4"	7 13/16"	5 3/16"	2 5/8"	2.5
521408AC	1/2"	3 3/8"	6 3/4"	6 7/16"	3 13/16"	2 5/8"	2.9
521418AC**	1/2"	3 3/8"	6 3/4"	7 13/16"	5 3/16"	2 5/8"	2.9
521508A	3/4"	3 3/16"	6 3/8"	7 1/4"	4 5/8"	2 5/8"	2.4
521518A**	3/4"	3 3/16"	6 3/8"	9 1/4"	6 5/8"	2 5/8"	2.5
521508AC	3/4"	3 11/16"	7 3/8"	7 1/4"	4 5/8"	2 5/8"	2.9
521518AC**	3/4"	3 11/16"	7 3/8"	9 1/4"	6 5/8"	2 5/8"	2.9
521608A	1"	3 9/16"	7 7/8"	7 5/8"	5"	2 5/8"	2.4
521618A**	1"	3 3/16"	7 1/8"	9"	6 3/8"	2 5/8"	2.5
521608AC	1"	4 1/16"	8 1/8"	7 5/8"	5"	2 5/8"	2.9
521618AC**	1"	4 1/16"	8 1/8"	9"	6 3/8"	2 5/8"	2.9

C at the end of the code are models with integral inlet port check valves.

*At minimum temperature position on adjusting knob.

**Model with integral outlet temperature gauge.

Temperature — exposure time

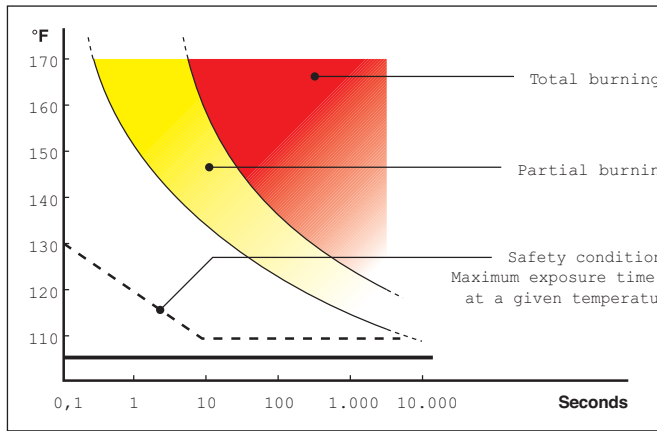

Legionella-scalding risk

In systems producing domestic hot water with storage, in order to avoid the dangerous infection known as Legionella, the hot water must be stored at a temperature of at least 140°F. At this temperature it is certain that the growth of the bacteria causing this infection will be totally eliminated. At this temperature, however, the water cannot be used directly.

As shown on the diagram opposite, temperatures of more than 120°F can cause burning very quickly. For example, at 130°F partial burning will occur in approximately 30 seconds, while at 140°F partial burning will occur in approximately 5 seconds. The time may be reduced by 50 percent or more for children and elderly people.

In view of the above, it is necessary to install a thermostatic mixing valve which can:

- reduce the temperature at the point of use to a value lower than that of storage and suitable for sanitary users. For safety reasons, it is advisable to limit the mixed water temperature to 120°F;
- maintain the temperature constant when the incoming pressure and temperature conditions vary.

Thermal disinfection

The diagram shows the behavior of the bacteria Legionella Pneumophila when the temperature conditions of the water in which it is contained vary. In order to ensure proper thermal “disinfection”, the values must not be below 140°F.

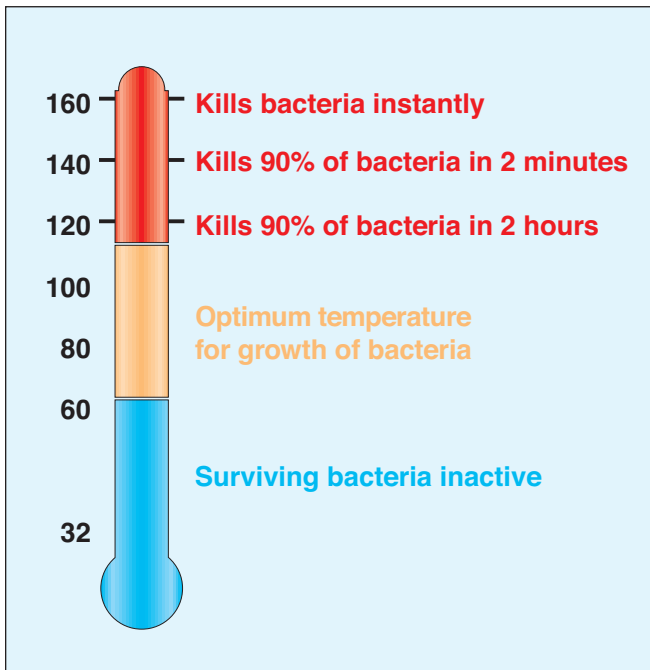

Operating principle

The controlling element of the three-way thermostatic mixing valve is a thermostatic sensor fully immersed in the mixed water outlet tube which, as it expands or contracts, continuously establishes the correct proportion of hot and cold water entering the valve. The regulation of these flows is by means of a piston sliding in a cylinder between the hot and cold water passages. Even when there are pressure drops due to the drawing off of hot or cold water for other uses, or variations in the incoming temperature, the thermostatic mixing valve automatically regulates the water flow to obtain the required temperature.

Construction details

Anti-scale materials

The material used in the construction of the Caleffi MixCal™ 521 series thermostatic mixing valve reduces jamming caused by lime deposits. All the working parts such as shutter, seats and slide guides are made of a special anti-scale material, with a low friction coefficient, assuring stable temperature control and long operating life.

Temperature setting and locking

The control knob permits temperature setting between minimum and maximum in one turn (360°). It also has a tamper-proof system to lock the temperature at the set value.

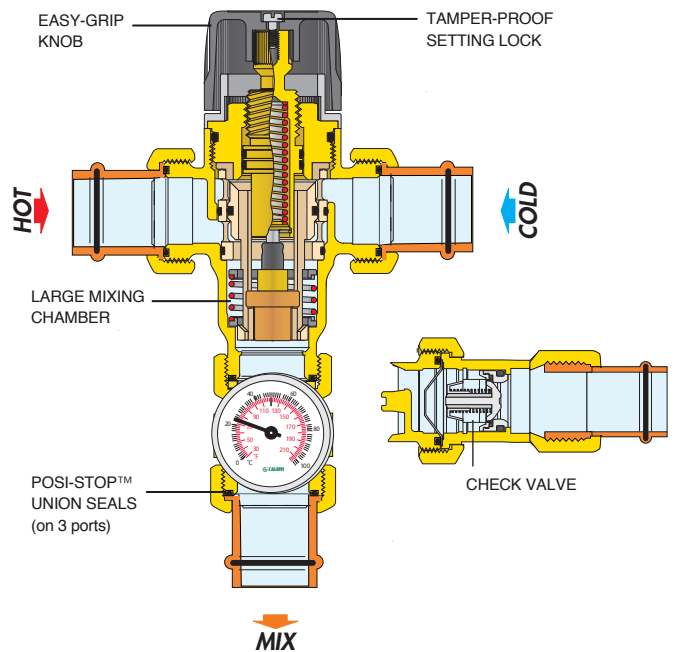

Flow curve

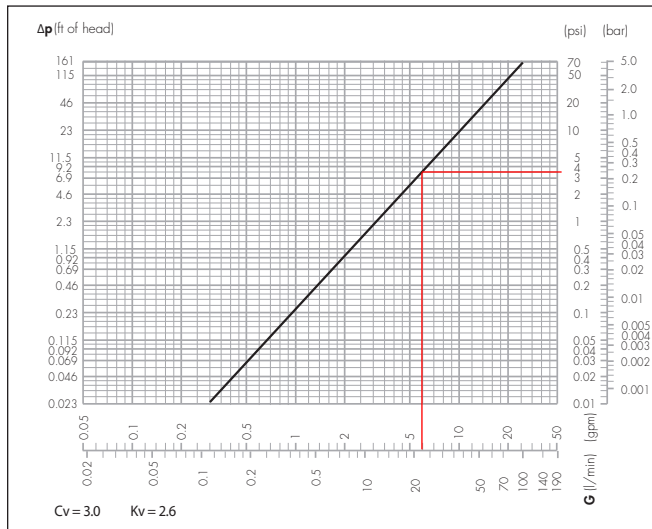

Flow should never exceed standards for pipe size and materials.

Use

Caleffi MixCal™ 521 series thermostatic mixing valves are designed to be installed at the hot water heater. The 521 series valve cannot be used for tempering water temperature at fixtures as a point-of-use valve. They are not designed to provide scald protection or chill protection service. They should not be used where ASSE 1070 devices are required. Wherever a scald protection feature is required, Caleffi 5213 series high performance mixing valves need to be installed. For safety reasons, it is advisable to limit the maximum mixed water temperature to 120°F.

Instantaneous production of hot water

Caleffi 5231 series thermostatic mixing valves are designed for use on domestic water heaters that have storage. The valve may deliver fluctuating mixed temperatures when used on instantaneous domestic water heaters.

Radiant heating systems

Caleffi MixCal™ 521 series thermostatic mixing valves can also be used for regulating the flow temperature in hydronic and radiant heating systems, to which it assures a constant and accurate control with ease of installation.

Temperature stability

The diagram shows the stability of the temperature of the mixed water on variation of the temperature of the stored water.

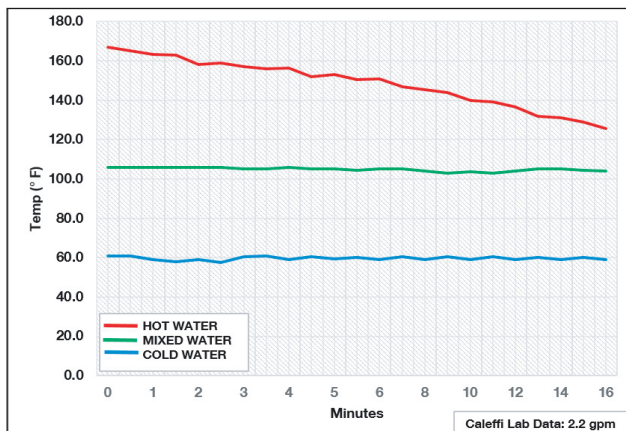

Installation

Before installing a Caleffi MixCal™ 521 series three-way thermostatic mixing valve, the system must be inspected to ensure that its operating conditions are within the range of the mixing valve, checking, for example, the supply temperature, supply pressure, etc.

Systems where the 521 series thermostatic mixing valve will be installed must be drained and cleaned out to remove any dirt or debris which may have accumulated during installation.

The installation of appropriately sized filters at the inlet from the main water supply is always advisable.

Caleffi MixCal™ 521 series thermostatic mixing valves must be installed by qualified personnel in accordance with the diagrams in this brochure, taking into account all current applicable standards.

Caleffi MixCal™ 521 series thermostatic mixing valves can be installed in any position, either vertical or horizontal, or upside down.

The following are shown on the thermostatic mixing valve body:

- Hot water inlet, color red and marked "HOT".
- Cold water inlet, color blue and marked "COLD".
- Mixed water outlet, marked "MIX".

Check valves

In order to prevent undesirable backsiphonage, check valves should be installed in systems with thermostatic mixing valves. As a convenience for easier installations, the Caleffi MixCal™ 521 "AC" series thermostatic mixing valves include integral check valves in the hot and cold inlet ports.

Commissioning

The Caleffi MixCal™ 521 series thermostatic mixing valve must be commissioned in accordance with current standards by qualified personnel using temperature measuring equipment. Caleffi 521419A, 521519A and 521619A with integral outlet port temperature gauges provide a time-saving temperature setting process to get close to the desired temperature. Use of a digital thermometer is recommended for determining the final setting of the mixed water temperature. Note: For models purchased without the outlet temperature gauge, the temperature gauge adapter with temperature gauge can be separately purchased and field installed, code NA10328 for 1/2" models, code NA10056 for 3/4" models or code NA10058 for 1" models.

Temperature adjustment

The temperature is set to the required value by means of the knob with the graduated scale, on the top of the valve.

Pos.	Min.	1	2	3	4	5	6	7	Max.
T (°F)	81	90	100	111	120	127	136	145	152
T (°C)	27	32	38	44	49	53	58	63	67

with: $T_{HOT} = 155^{\circ}F (68^{\circ}C)$, with: $T_{cold} = 55^{\circ}F (13^{\circ}C)$, $P = 43 \text{ psi } (13 \text{ bar})$

Locking the setting

Position the handle to the number required with respect to the index point. Unscrew the head screw, pull off the handle and reposition it so that the handle fits into the internal slot of the knob. Tighten the head screw.

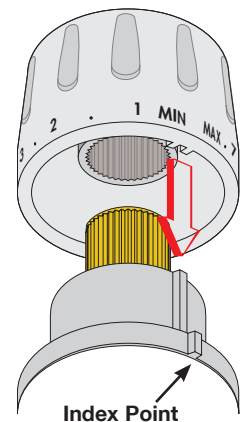

Replacement parts and accessories



Replacement body.
Meets requirements of
NSF/ANSI/CAN 372-2011.
Certified to: ASSE 1017/CSA B125.3,
Low lead, by ICC-ES file PMG-1360.



Point of distribution mixed temperature
gauge adaptor fits MixCal™ 521 series
mixing valves. Threaded union mounting
replaces existing mixed outlet with 3/4" or 1"
sweat pipe connection. Removable gauge
fits into temperature well. Gauge dial is 2"
diameter and dual-scale (not pictured) from
30—210° F (0—100° C).



521101A.....1" male union thread

NA10328.....1/2" sweat with gauge
NA10056.....3/4" sweat with gauge
NA10058.....1" sweat with gauge
NA10358.....1" union thread with gauge
688003A.....replacement gauge with pocket well
R39591.....replacement gauge
NA10498.....pocket well, plated



Replacement check valves.



Conical inlet filter.

Isolation ball valve



Low lead Male x Female union fits 1" valves
between body and tailpiece. See below.

Replacement fittings

Refer to current Caleffi Plumbing and Hydronics Catalog, fittings and
miscellaneous components section for replacement tailpiece, union nut and
washer parts.

290030.....isolation ball valve 1" M x 1" F union



Isolation ball valves, installed on MixCal without
optional temperature gauge.

Recirculation with point-of-distribution thermostatic mixing valves

For domestic recirculating water systems that include a single ASSE 1017 point-of-distribution thermostatic mixing valve, such as the Caleffi MixCal™ 521 series, the piping installation below is recommended.

In any recirculating hot water distribution system there will be times when the circulator is operating, but no hot water is being drawn at the fixtures. Under this condition, heat continually dissipates from the piping forming the recirculation loop. If the loop is relatively short, and well insulated, the rate of heat loss should be very small. If the loop is long, and uninsulated, the rate of heat loss could be substantially greater.

To maintain the recirculating water at the desired delivery temperature the heat lost from the loop must be replaced. This requires some water flow between the loop and the hot water source. Ideally, this flow is adjusted so that the rate of heat transfer from the hot water source to the loop exactly balances the rate of heat loss from the loop's piping.

The figure (below) shows a "bypass valve" (1), and "return valve" (2), which regulate how much warm water from the return side of the recirculating loop flows back to the storage tank. When there is no demand for hot water at the fixtures, the flow of return water to the tank will equal the rate of hot water flow from the tank to the inlet port of the mixing valve. Ideally, this flow should be adjusted so that the rate of heat transfer from the tank to the recirculating loop exactly balances the rate of heat loss from the recirculating loop. This allows the water temperature leaving the mixing valve to remain stable.

The bypass valve (1) and possibly the return valve (2) must be adjusted when there is no domestic water draw on the recirculating loop (when all the fixtures are off). Begin with the bypass valve (1) fully closed, and the return valve (2) fully open. Turn on the recirculating circulator and let it run for several minutes. The supply water temperature leaving the mixing valve will likely be lower than the setting of the valve, since there is no return flow to the tank thus, no hot water to the hot port of the mixing valve.

Slowly open the bypass valve (1) and monitor the temperature leaving the mixing valve. It will likely begin rising as some water returns to the tank, and an equal flow of hot water moves from the tank to the hot port of the mixing valve. When the temperature leaving the mixing valve remains stable, and is at or very close to the temperature set on the mixing valve, the bypass valve is correctly set.

The return valve (2) can remain fully open unless a situation occurs where the bypass valve (1) is fully open, but the temperature leaving the mixing valve is still too low. If this occurs, partially close the return valve (2) to add flow resistance. This forces more flow through the bypass valve (1). Repeat the previously described procedure of slowly opening the bypass valve (1) until the water temperature leaving the mixing valve is stable.

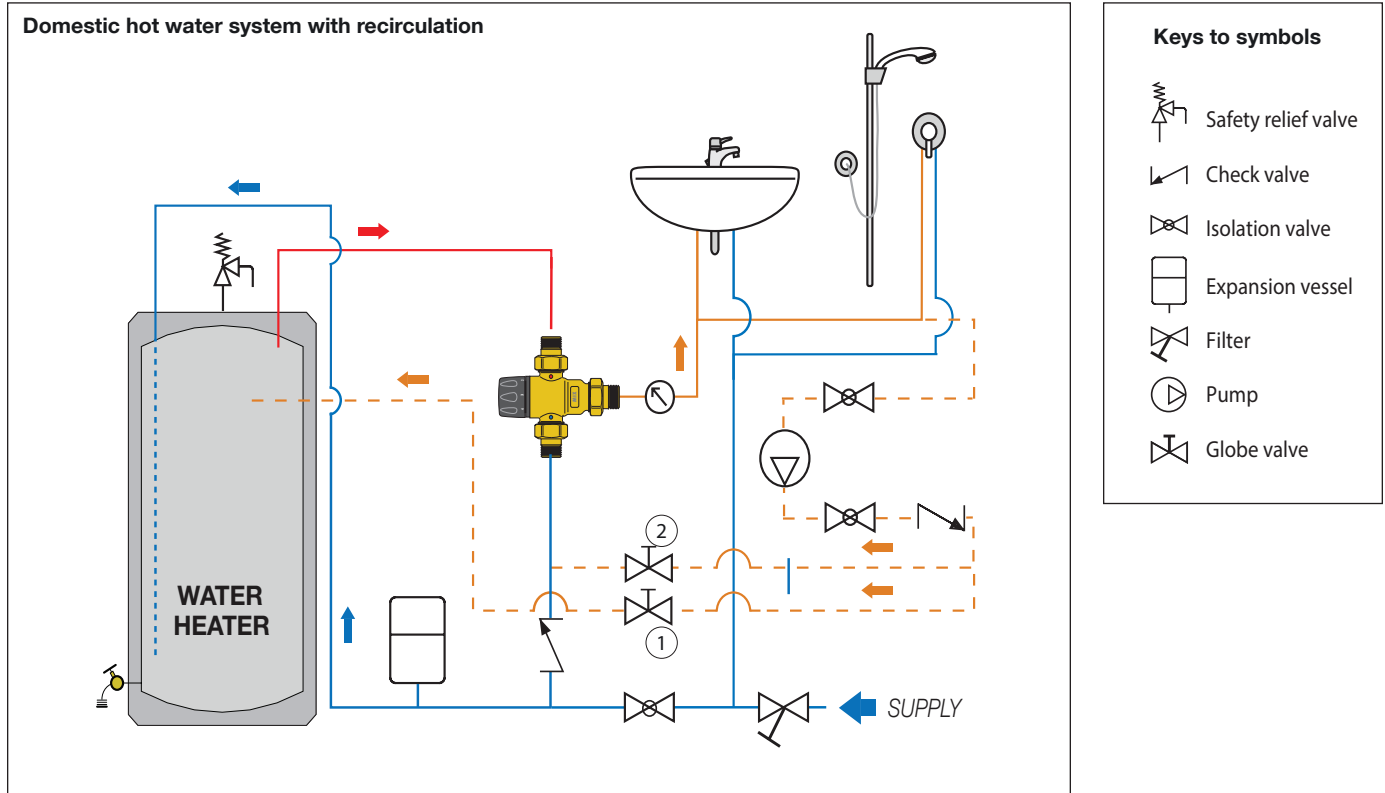

Application diagrams

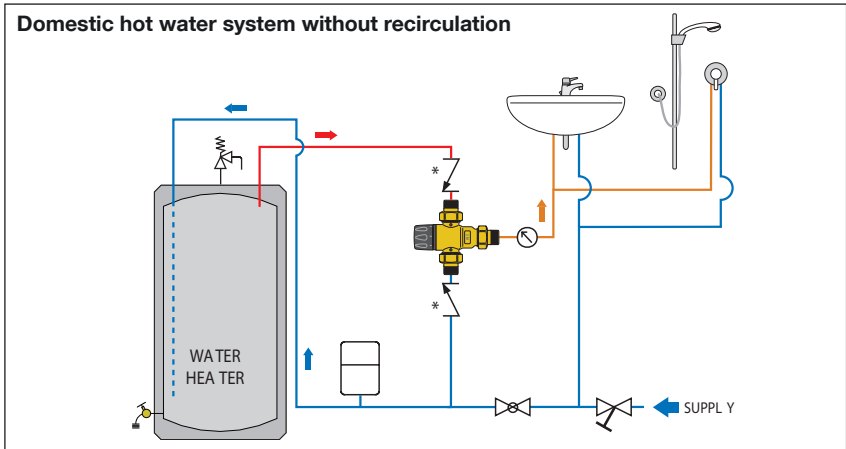
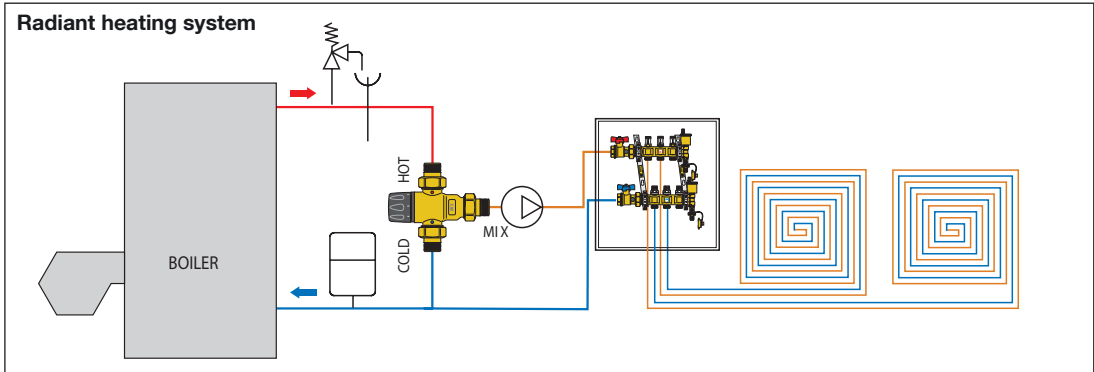

Keys to symbols

- Safety r elief valve
- Check valve
- Isolation valve
- Expansion vessel
- Filter
- Pump

**MixCal™ 521 series thermostatic mixing valves with inlet check valves, "AC" models, can be used instead of separately installed check valves.*

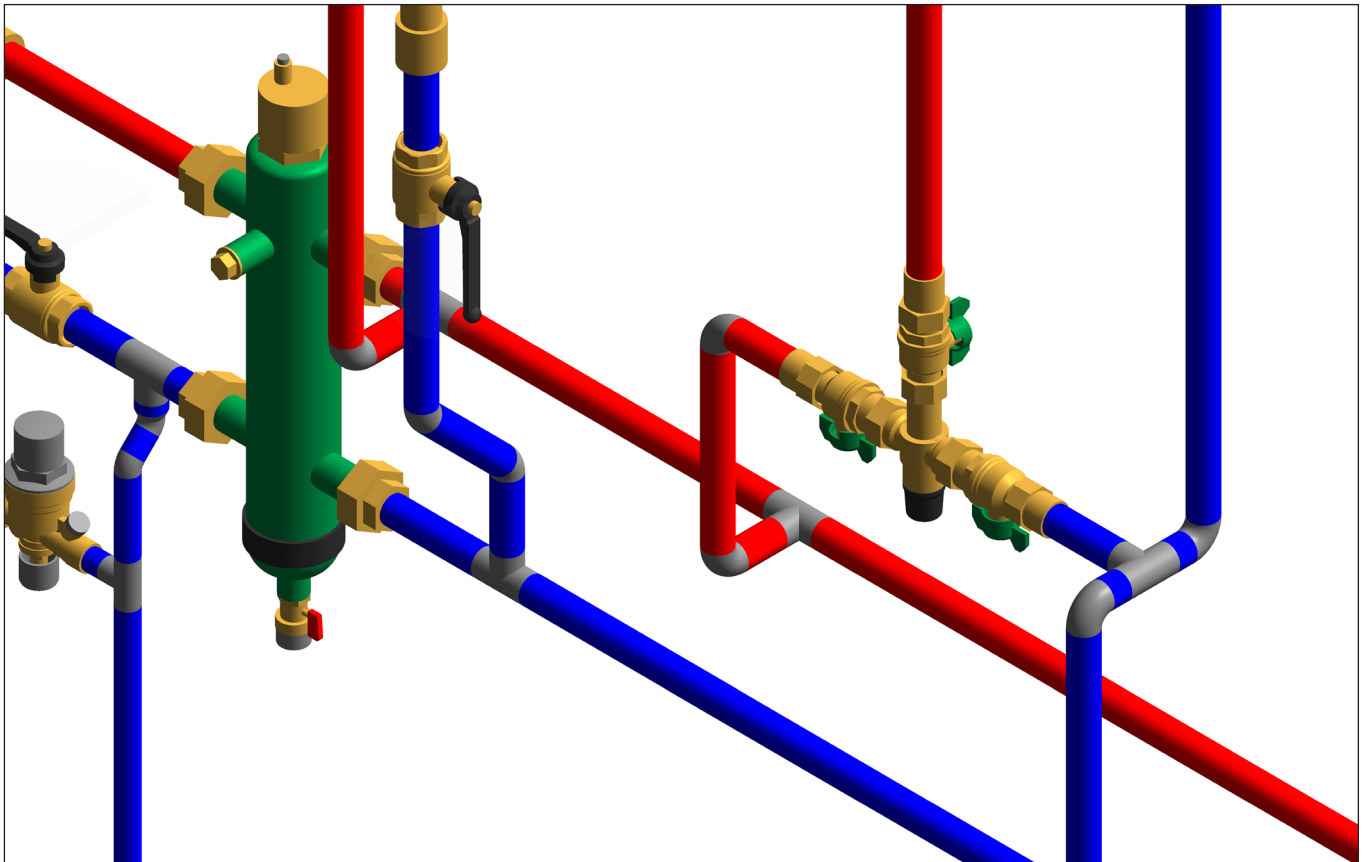

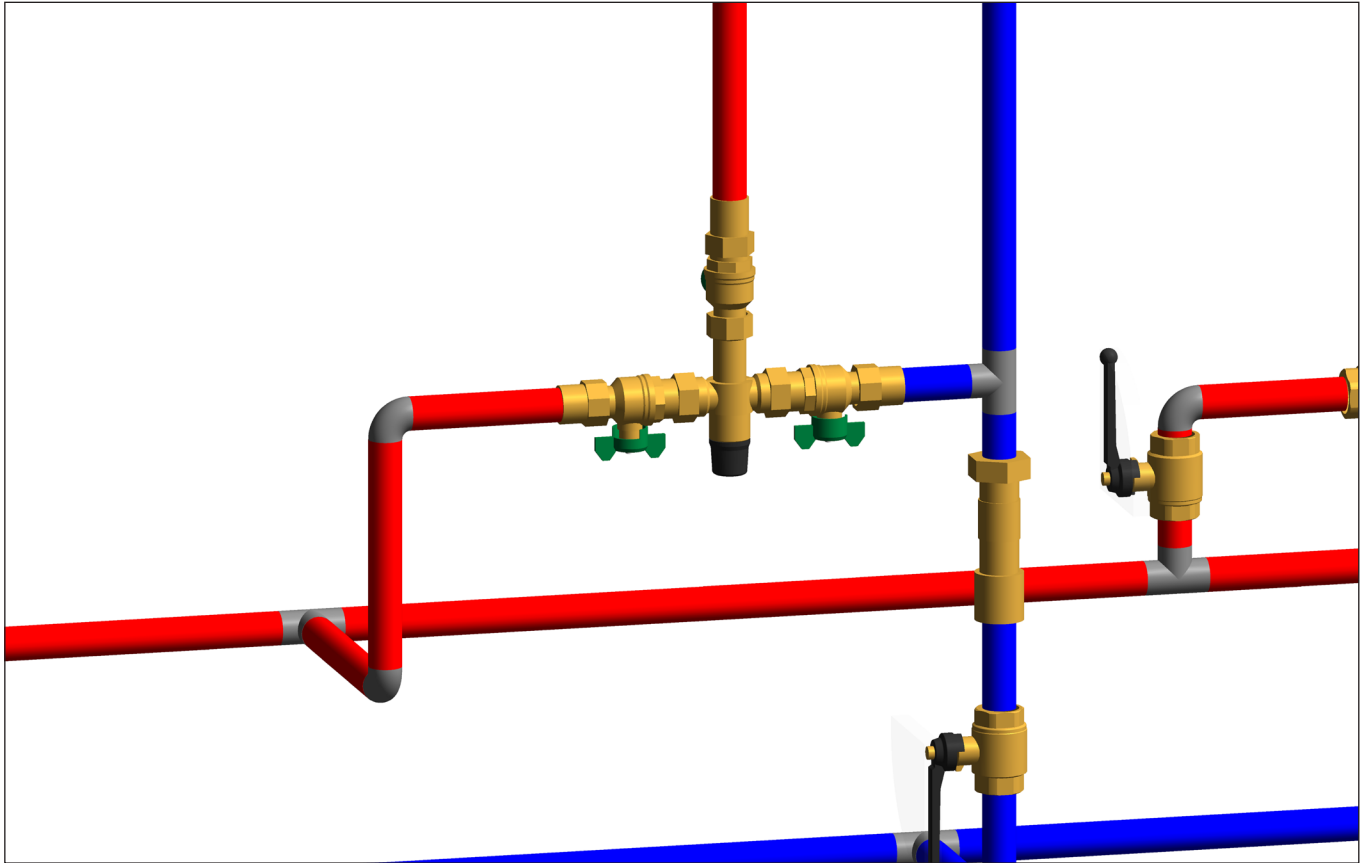

Find us in

MasterSpec®

Powered by Deltek Specpoint®

<https://get.caleffi.info/specpoint>



find BIM Revit files and system templates at
<https://bim.caleffi.com/en-us>

SPECIFICATION SUMMARY

MixCal™ 521 series

Adjustable thermostatic and pressure balanced mixing valve, certified by ICC-ES to ASSE 1017-2009 and CSA B125.3, approved for point of distribution domestic water systems and radiant hydronic heating systems. Sweat, Press, PEX crimp, PEX expansion and threaded connections ½", ¾" or 1" NPT male with union tailpieces. Low-lead brass body (<0.25% Lead content) certified by ICC-ES file 1360. Meets requirements of NSF/ANSI/CAN 372-2011. Shutter, regulating seats and sliding surfaces in anti-scale plastic, PPO. Seals peroxide-cured EPDM. Stainless steel spring. Maximum working temperature 200 degrees F (93 degrees C). Setting range 85 degrees F to 150 degrees F (30 degrees C to 65 degrees C). Maximum working pressure 200 psi (14 bar). Maximum operating differential pressure 75 psi (5 bar). Tolerance ±3 degrees F (±2 degrees C). Flow rating: Cv 3.0. Minimum flow to ensure optimal performance: 1.0 gpm (3.8 L/min). Minimum flow rate when recirculation flow rate is 1 gpm or greater: 0 gpm. Provided with tamper-proof setting lock. Provide with optional inlet port check valves. Provide with optional mixed outlet dual-scale temperature gauge, 30 to 210 degrees F scale and 0 to 100 degree C scale, 2 inch diameter. Provide with optional inlet and outlet isolation ball valves, code 290030, separately sourced, field installed.

We reserve the right to change our products and their relevant technical data, contained in this publication, at any time and without prior notice.



Caleffi North America, Inc.
 3883 W. Milwaukee Road, Milwaukee, WI 53208
 Tel: 414-238-2360 · Fax: 414-238-2366
 Technical Support: 414-338-6338 / techsupport.us@caleffi.com
 sales@caleffi.com · www.caleffi.com
 © Copyright 2023 Caleffi North America, Inc.