



Department of Management Services
Purchasing Division
241 West South Street
Kalamazoo, MI 49007-4796
Phone: 269.337.8020
www.kalamazoo-city.org
cokpurchasing@kalamazoo-city.org

INVITATION FOR BID (IFB)

The City of Kalamazoo, Michigan is soliciting sealed bids for:

PROJECT NAME: Michikal-Kalamazoo-Westnedge Signal **BID REFERENCE #: 96880-006.0**

IFB ISSUE DATE: July 2, 2025

BID DUE/OPENING DATE: July 24, 2025 @ 3:30 p.m. Local Time
Electronic Bids Will Not Be Accepted.

MAILING ADDRESS & INSTRUCTIONS

Mail to:

Purchasing Division
241 W. South Street
Kalamazoo, MI 49007

Questions about this IFB should be directed to:

Department Contact: Tom Palumbo,
Senior Civil Engineer-Public Services
at palumbot@kalamazoo-city.org

Include on the Envelope the Project Name and Bid Reference Number. All Envelopes Must Be Sealed.

You are invited to submit a bid for this project. Specifications, terms, conditions and instructions for submitting bids are contained herein. This Invitation for Bid with all pages, documents and attachments contained herein, or subsequently added to and made a part hereof, submitted as a fully and properly executed bid shall constitute the contract between the City and the successful bidder when approved and accepted on behalf of the City by an authorized official or agent of the City. Please review the bid document as soon as possible and note the **DEADLINE FOR QUESTIONS** in the Instructions to Bidders.

All bidders shall complete and return the Bid and Award page(s) and submit all information requested herein in order for a bid to be responsive. The bid document shall be returned in its entirety, in a properly identified and sealed envelope to the Purchasing Division at the above address. **BIDS MUST BE RECEIVED BEFORE THE DUE DATE - LATE BIDS WILL NOT BE CONSIDERED.** The City reserves the right to postpone the bid opening for its own convenience.

TABLE OF CONTENTS

<u>SECTION</u>	<u>PAGE #</u>	<u>APPENDICES</u>
		Statement of No Bid
I	1 - 2	Appendix A
II	3 - 11	Plans
III	12 - 13	Special Provisions
IV	14 - 15	
V	16 - 22	
VI	23 - 28	

STATEMENT OF NO BID

NOTE: If you DO NOT intend to bid on this commodity or service, please complete and return this form immediately. Your response will assist us in evaluating all responses for this important project and to improve our bid solicitation process.

The Purchasing Division of the City of Kalamazoo wishes to keep its bidders list file up-to-date. If, for any reason you cannot supply the commodity/service noted in this bid solicitation, this form must be completed and returned to remain on the particular bid list for future projects of this type.

If you do not respond to this inquiry within the time set for the bid opening date and time noted, we will assume that you can no longer supply this commodity/service, and your name will be removed from this bid list.

- _____ Specifications too "tight", i.e. geared toward one brand or manufacturer only (explain below).
- _____ Specifications are unclear (explain below).
- _____ We are unable to meet specifications.
- _____ Insufficient time to respond to the Invitation for Bid.
- _____ Our schedule would not permit us to perform.
- _____ We are unable to meet bond requirements.
- _____ We are unable to meet insurance requirements.
- _____ We do not offer this product or service.
- _____ Remove us from your bidders list for this commodity or service.
- _____ Other (specify below).

REMARKS: _____

SIGNED: _____ NAME: _____
(Type or Print)

TITLE: _____ DATE: _____

FIRM NAME: _____
(if any)

ADDRESS: _____
(Street address) (City) (State) (Zip)

PHONE: _____ FAX: _____

EMAIL: _____

**SECTION I
INSTRUCTIONS TO BIDDERS**

1. **EXAMINATION OF BID DOCUMENT**-Before submitting a bid, bidders shall carefully examine the specifications and shall fully inform themselves as to all existing conditions and limitations. The bidder shall indicate in the bid the sum to cover the cost of all items included on the bid form.
2. **PREPARATION OF BID**-The bid shall be legibly prepared in ink or typed. If a unit price or extension already entered by the bidder on the Bid and Award form is to be altered, it shall be crossed out and the new unit price or extension entered above or below and initialed by the bidder with ink. The bid shall be legally signed and the complete address of the bidder given thereon.

All bids shall be tightly sealed in an envelope plainly marked SEALED BID and identified by project name, bid opening date and time. Bids opened by mistake, due to improper identification, will be so documented and resealed. The Purchasing Division will maintain and guarantee confidentiality of the contents until the specified opening date and time. Bids submitted by Fax machine will not be accepted.
3. **EXPLANATION TO BIDDERS**-Any binding explanation desired by a bidder regarding the meaning or interpretation of the Invitation for Bid (IFB) and attachments must be requested in writing, at least business 5 days before the bid opening so a reply may reach all prospective bidders before the submission of bids. Any information given to a prospective bidder concerning the IFB will be furnished to all prospective bidders as an amendment or addendum to the IFB if such information would be prejudicial to uninformed bidders. Receipt of amendments or addenda by a bidder must be acknowledged in the bid by attachment, or by letter received before the time set for opening of bids. Oral explanation or instructions given prior to the opening will not be binding.
4. **CASH DISCOUNTS**-Discount offered for payment of less than thirty (30) days will not be considered in evaluating bids for award. Offered discounts of less than thirty (30) days will be taken if payment is made within the discount period, even though not considered in evaluation of the bid.
5. **WITHDRAWAL OF BIDS**-Bids may be withdrawn in person by a bidder or authorized representative, provided their identity is made known and a receipt is signed for the bid, but only if the withdrawal is made prior to the exact time set for receipt of bid. No bid may be withdrawn for at least ninety (90) days after bid opening.
6. **ALTERNATE BIDS**-bidders are cautioned that any alternate bid, unless specifically requested or any changes, insertions or omissions to the terms and conditions, specifications or any other requirement of this IFB may be considered non-responsive, and at the option of the City, result in rejection of the alternate bid.
7. **LATE BIDS**-Any bid received at the office designated herein after the exact time specified for receipt will not be considered. (Note: The City reserves the right to consider bids that have been determined by the City to be received late due to mishandling by the City after receipt of the bid and no award has been made.)
8. **UNIT PRICES**-If there is a discrepancy between unit prices and their extension, unit prices shall prevail.
9. **BID SUBMITTAL**- Bidders can submit sealed bids in one of the following ways:
 - 9.1. **Mail your bid**, to be received before the bid due date and time indicated in the bid document, to the City of Kalamazoo at the following address:

City of Kalamazoo
Purchasing Division
241 West South Street
Kalamazoo, MI 49007

- 9.2. **Deliver your bid to City Hall In-Person** before the bid due date and time indicated in the bid document.
- 9.3. **Deliver your bid to the Treasurer’s Office Payment Drop Box** located in the northwest corner of City Hall (see photos below) before the bid due date and time indicated in the bid document.



1. Open drop box located at City Hall.

2. Insert SEALED BID here.



- 10. **BID TABULATIONS-** The Purchasing Division makes an effort to post bid tabulations to the City of Kalamazoo website within 24 hours after the bid opening date and time at: <https://www.kalamazoocity.org/bidopportunities>. However, in certain cases the posting of the bid tabulation may extend beyond the 24-hour window.

SECTION II
BID AND AWARD

The undersigned having become thoroughly familiar with all of the bid/contract documents incorporated herein, the project site and the location conditions affecting the work, hereby proposes to perform everything required to be performed in strict conformity with the requirements of these documents, and to provide and furnish all the equipment, labor and materials necessary to complete in a professional manner the furnishing and installing of all of the following, meeting or exceeding the specifications as set forth herein for the prices as stated below.

Michikal-Kalamazoo-Westnedge Signal

ITEM	QTY	UNIT	UNIT PRICE	EXTENDED PRICE
Mobilization, Max \$5,000	1	LSUM		
Curb and Gutter, Rem	10	Ft		
Pavt, Rem, Modified	3	Syd		
Erosion Control, Inlet Protection, Fabric Drop, Modified	1	Ea		
Hand Patching	1	Ton		
Conc Base Cse, Nonreinf, 6 inch	3	Syd		
Detectable Warning Surface	6	Ft		
Curb Ramp Opening, Conc	10	Ft		
Sidewalk, Conc, 4 inch	10	Sft		
Curb Ramp, Conc, 6 inch	80	Sft		
Pavt Mrkg, Waterborne, 12 inch, Cross Hatching, White	190	Ft		
Traffic Control	1	LSUM		
Slope Restoration, Non-Freeway, Type F	60	Syd		
Conduit, Directional Bore, 1, 3 inch	90	Ft		
Conduit, DB, 1, 1 1/2 inch	45	Ft		
Conduit, DB, 1, 4 inch	20	Ft		
Conduit, DB, 4, 3 inch	10	Ft		
Cable, Sec, 600V, 1, 3/C#6	50	Ft		
Bracket Arm, Clamp On, Rem	1	Ea		
Hh, Round	1	Ea		
Hh, Round, 3 foot dia	1	Ea		
Hh, Adj	1	Ea		
Hh, Rem	1	Ea		
Unmetered Serv, Rem	1	Ea		
Wood Pole, Cl 4, 40 foot	1	Ea		

ITEM	QTY	UNIT	UNIT PRICE	EXTENDED PRICE
Serv Disconnect, Rem	1	Ea		
Wood Pole, Fit Up, TS Cable Pole	1	Ea		
Steel Pole, Fit Up, TS Cable Pole	1	Ea		
Controller and Cabinet, Salv	1	Ea		
Case Sign, Salv	1	Ea		
Controller Fdn, Base Mtd	1	Ea		
Controller Fdn, Rem	1	Ea		
Fdn, Rem	1	Ea		
Pedestal, Alum	1	Ea		
Pedestal, Fdn	2	Ea		
Pedestal, Underground Serv, Metered	1	Ea		
Riser	1	Ea		
Span Wire	1	Ea		
Span Wire, Rem	1	Ea		
Span Wire Tether	1	Ea		
Steel Pole, Rem	1	Ea		
TS, One Way Span Wire Mtd, Salv	2	Ea		
TS, Two Way Span Wire Mtd, Salv	2	Ea		
TS, Pedestrian, One Way Bracket Arm Mtd, Salv	1	Ea		
TS, Pedestrian, Two Way Bracket Arm Mtd, Salv	1	Ea		
TS, Wireless Link, Rem	1	Ea		
TS, Antenna, Rem	3	Ea		
GRAND TOTAL				

Bidder shall provide all of the information as requested herein with their bid. **Failure to do so and/or failure to provide post-bid requested information may be cause for rejecting the bid as non-responsive.**

Work shall start within **10** working days after receipt of notification by Contractor of Notice to Proceed, and final completion date on or before **October 1, 2025**.

Bidder/Contractor has examined and carefully studied the bidding documents and attachments, and acknowledges receipt of the following addenda:

Addendum No: _____

Dated: _____

By my signature below, I certify that the firm bidding on this contract, when making hiring decisions, does not use a past criminal conviction as a bar to or preclude a person with a criminal conviction from being considered for employment with the bidding firm unless otherwise precluded by federal or state law. I further certify that I have read and agree to be bound by the provisions of the City's Non-Discrimination Clause found in Appendix A as updated by City Ordinance 1856.

Signed: _____ Name: _____

Title: _____

CITY OF KALAMAZOO EX-OFFENDER POLICY CHECKLIST

As part of the City’s commitment to reducing unacceptable poverty, encouraging rehabilitation, reducing recidivism and strengthening families in Kalamazoo, the City has updated its Purchasing Policy to ensure that firms with whom the City does business share in this commitment by utilizing hiring practices that do not unfairly deny people with arrest and conviction records gainful employment. *(Important: This requirement also extends to any subcontractors the bidder intends to use to fulfill the contract for goods or services being sought from the City.)*

Part I: Proof that the bidder does not inquire about an individual’s past arrest or criminal history on the bidders employment application form

- Attach a copy of the current application for employment being used by the bidder

Part II: Certification that the bidder does not use an individual’s past arrest or criminal history to unlawfully discriminate against them by checking *one or more* of the following:

- That pursuant to federal or state law bidder is precluded from hiring persons with certain criminal records from holding particular positions or engaging in certain occupations by providing a cite to the applicable statute or regulation; if checking this box, provide a citation to the applicable statute or rule upon which the bidder is relying:_____
- That bidder conducts criminal history background checks only as necessary, and only after making a conditional offer of employment; that any withdrawal of an offer of employment to an individual because of a past criminal history is job-related and consistent with business necessity after the individual has been provided an individualized assessment opportunity to review and challenge or supplement the history of past criminal conduct being relied upon by the bidder;
- That the use by bidder of criminal history background checks complies with the U.S. Equal Employment Opportunity Commission’s Enforcement Guidance on the Consideration of Arrest and Conviction Records in Employment Decisions and that the bidder has not had a determination rendered against it in past 7 years that it discriminated against a person through the use of an individual’s arrest or criminal history

I CERTIFY THAT THE ABOVE STATEMENTS ARE TRUE.

Date

Signature

Printed Name

Position

CITY OF KALAMAZOO
LOCAL PREFERENCE POLICY AND CERTIFICATION

The lowest responsive Kalamazoo County bidder whose bid is not low but falls within 2% of the lowest responsive bid is afforded the opportunity to become the successful bidder if it agrees to reduce its bid to match the lowest responsive bid. The City of Kalamazoo is the sole determiner whether a bidder is responsible, qualifies as a Kalamazoo County bidder, and if its bid is responsive to the City’s specifications, terms and conditions.

If the lowest Kalamazoo County bidder chooses not to match the lowest bid, the next lowest responsive Kalamazoo County bidder whose bid falls within 2% of the lowest bid, is given the opportunity to match the lowest responsive bid.

To qualify as a Kalamazoo County bidder, the bidder must meet both the following criteria:

1. Have a physical presence in Kalamazoo County by maintaining a permanent office, factory or other facility in Kalamazoo County with employees working in Kalamazoo County.
2. Have paid real or personal property taxes related to said business to the City of Kalamazoo, County of Kalamazoo or other municipal corporation within Kalamazoo County in the previous tax year, except that a non-profit entity need not meet this requirement.

This local preference policy applies only to purchases for materials, supplies, capital outlay, and services for maintenance, repair or operation of City facilities that are over \$25,000. If more than 50% of the contract is sub-contracted to firms located outside of Kalamazoo County that bid does not qualify for the local preference policy outlined above. The local preference policy will not apply if prohibited by law. The Purchasing Agent has the authority to finally determine if the bidder qualifies as a Kalamazoo County bidder as set forth herein. The Purchasing Agent may take into account the permanency of the business in Kalamazoo, and whether the business appears to be claiming to be a Kalamazoo County business solely or primarily to qualify as a Kalamazoo County business under this Resolution, and any other material factors.

CERTIFICATION

If you qualify as a Kalamazoo County bidder and wish to be considered for the local preference provisions as provided above please certify that fact by providing the information requested below and attesting to its accuracy.

Firm Name: _____

Street Address of Business: _____

City, State, and Zip Code: _____

Number of employees working in Kalamazoo County: _____

Name the city or township to which business real and/or personal property taxes are paid or provide non-profit status: _____

The above information is accurate:

Signature: _____ Date: _____

Title: _____

REFERENCE QUESTIONNAIRE

Please answer the following questions completely.

1. Firm name: _____
2. Established: Year _____ Number of Employees: _____
3. Type of organization:
 - a. Individual: _____
 - b. Partnership: _____
 - c. Corporation: _____
 - d. Other: _____
4. Former firm name(s) if any, and year(s) in business:

5. Include at least 5 references of contracts for similar work performed over the last five (5) years. The City of Kalamazoo Water System is a Type 1 Public Water Supply. For the protection of public health, the City requires that any contractor performing work on the water system is qualified with experience working on other Type 1 Public Water Supply Systems with projects of similar scope to this bid. Include: owner, contact person and phone number and description of work performed.
 - 5.1 Company Name: _____
Address: _____
Phone: _____
Contact: _____
Type of work or contract: _____
 - 5.2 Company Name: _____
Address: _____
Phone: _____
Contact: _____
Type of work or contract: _____
 - 5.3 Company Name: _____
Address: _____
Phone: _____
Contact: _____
Type of work or contract: _____

5.4 Company Name: _____
Address: _____
Phone: _____
Contact: _____
Type of work or contract: _____

5.5 Company Name: _____
Address: _____
Phone: _____
Contact: _____
Type of work or contract: _____

I hereby certify that all of the information provided is true and answered to the best of my ability.

Signed: _____ Name: _____
(type or print)

Title: _____ Date: _____

I hereby state that all of the information I have provided is true, accurate and complete. I hereby state that I have the authority to submit this bid which will become a binding contract if accepted by the City of Kalamazoo. I hereby state that I have not communicated with nor otherwise colluded with any other bidder, nor have I made any agreement with nor offered/accepted anything of value to/from an official or employee of the City of Kalamazoo that would tend to destroy or hinder free competition.

The firm's identification information provided will be used by the City for purchase orders, payment, and other contractual purposes. If the contractual relationship is with, or the payment made to, another firm please provide a complete explanation on your letterhead and attach to your bid. Please provide for accounts payable purposes:

Tax Identification Number (Federal ID): _____

Remittance Address: _____

Financial Contact Name: _____ Financial Contact Phone Number: _____

Financial Contact Email Address: _____

I hereby state that I have read, understand and agree to be bound by all terms and conditions of this bid document.

SIGNED: _____ NAME: _____
(Type or Print)

TITLE: _____ DATE: _____

FIRM NAME: _____
(if any)

ADDRESS: _____
(Street address) (City) (State) (Zip)

PHONE: _____ FAX: _____

EMAIL ADDRESS: _____

FOR CITY USE ONLY - DO NOT WRITE BELOW

**SECTION III
CITY OF KALAMAZOO
INDEMNITY AND INSURANCE**

Contractor, or any of their subcontractors, shall not commence work under this contract until they have obtained the insurance required under this paragraph, and shall keep such insurance in force during the entire life of this contract. All coverage shall be with insurance companies licensed and admitted to do business in the State of Michigan and acceptable to the City of Kalamazoo within ten (10) days of the Notice of Award. The requirements below should not be interpreted to limit the liability of the Contractor. All deductibles and SIR's are the responsibility of the Contractor.

The Contractor shall procure and maintain the following insurance coverage:

Workers' Compensation Insurance including Employers' Liability Coverage, in accordance with all applicable statutes of the State of Michigan.

Commercial General Liability Insurance on an "Occurrence Basis" with limits of liability not less than \$1,000,000 per occurrence and aggregate. Coverage shall include the following extensions: (A) Contractual Liability; (B) Products and Completed Operations; (C) Independent Contractors Coverage; (D) Broad Form General Liability Extensions or equivalent, if not already included and (E) XCU coverage if the nature of the contract requires XC or U work.

Automobile Liability including Michigan No-Fault Coverages, with limits of liability not less than \$1,000,000 per occurrence, combined single limit for Bodily Injury, and Property Damage. Coverage shall include all owned vehicles, all non-owned vehicles, and all hired vehicles.

Additional Insured: Commercial General Liability and Automobile Liability, as described above, shall include an endorsement stating that the following shall be *Additional Insureds*: The City of Kalamazoo, all elected and appointed officials, all employees and volunteers, all boards, commissions, and/or authorities and board members, including employees and volunteers thereof. It is understood and agreed that by naming the City of Kalamazoo as additional insured, coverage afforded is considered to be primary and any other insurance the City of Kalamazoo may have in effect shall be considered secondary and/or excess.

To the fullest extent permitted by law the Contractor agrees to defend, pay on behalf of, indemnify, and hold harmless the City of Kalamazoo, its elected and appointed officials, employees, agents and volunteers, and others working on behalf of the City of Kalamazoo against any and all claims, demands, suits, or loss, including all costs connected therewith, and for any damages which may be asserted, claimed, or recovered against or from the City of Kalamazoo, by reason of personal injury, including bodily injury or death and/or property damage, including loss of use thereof, which arises out of, or is in any way connected or associated with this contract.

Cancellation Notice: All policies, as described above, shall include an endorsement stating that it is understood and agreed that thirty (30) days, or ten (10) days for non-payment of premium, Advance Written Notice of Cancellation, Non-Renewal, Reduction, and/or Material Change shall be sent to: City of Kalamazoo, Purchasing Division, 241 W. South Street, Kalamazoo, MI 49007.

Proof of Insurance Coverage: The Contractor shall provide the City of Kalamazoo at the time that the contracts are returned by him/her for execution, or within 10 days of Notice of Award, whichever is earlier, a Certificate of Insurance as well as the required endorsements. In lieu of required endorsements, if applicable, a copy of the policy sections where coverage is provided for additional insured and cancellation notice would be acceptable. Copies or certified copies of all policies mentioned above shall be furnished, if so requested.

INDEMNITY AND INSURANCE

Continued

If any of the above coverages expire during the term of this contract, the Contractor shall deliver renewal certificates and/or policies to City of Kalamazoo at least ten (10) days prior to the expiration date.

Scope of Coverage: The above requirements and conditions shall not be interpreted to limit the liability of the Contractor under this Contract, but shall be interpreted to provide the greatest benefit to the City and its officers and employees. The above listed coverages shall protect the Contractor, its employees, agents, representatives and subcontractors against claims arising out of the work performed. It shall be the Contractor's responsibility to provide similar insurance for each subcontractor or to provide evidence that each subcontractor carries such insurance in like amount prior to the time such subcontractor proceeds to perform under the contract.

SECTION IV
SPECIAL REQUIREMENTS

1. BID BOND/GUARANTEE

The bid must be accompanied by a bid bond which shall not be less than five (5%) percent of the total amount of the bid. No bid will be considered unless it is accompanied by the required guarantee. The bid guarantee shall ensure the execution of the bid and award, and the furnishing of a performance bond and a labor and material bond (A and B below) by the successful bidder. (Contractors Note: A cashier's or certified check in lieu of a bid bond is **NOT** acceptable.)

A. PERFORMANCE BOND

A performance bond shall be furnished in the full amount of the contract ensuring the City of faithful performance of all the provisions of the contract, and the satisfactory performance of any equipment required hereunder. The bond shall also ensure the City against defective workmanship and/or materials.

B. LABOR AND MATERIAL (PAYMENT) BOND

A labor and material (payment) bond shall be furnished for the period covered by the contract, in the full amount of the contract for the protection of labor and material suppliers and sub-contractors.

Bonds shall be secured by a guaranty or a surety company listed in the latest issue of the U.S. Treasury, circular 570, and licensed to do business in the State of Michigan, and written in favor of the City of Kalamazoo. The amount of such bonds shall be within the maximum amount specified for such company in said circular 570. The bonds shall be accompanied by a power of attorney showing authority of the bonding agent to sign such bonds on behalf of the guaranty or surety company. The cost of the bonds shall be borne by the Contractor.

Failure of the Contractor to supply the required bonds within ten (10) days after Notice of Award, or within such extended period as the Purchasing Agent may agree to, shall constitute a default and the City of Kalamazoo may either award this contract to the next lowest bidder or re-advertise for bids and may charge against the Contractor for the difference between the amount of the bid and the amount for which a contract for the work is subsequently executed, irrespective of whether the amount thus due exceeds the amount of the bid bond. If a more favorable bid is received by re-advertising, the defaulting bidder shall have no claim against the City of Kalamazoo for a refund.

2. WAIVERS OF LIEN

Upon completion of all work and request for final payment, the Contractor shall furnish a 100% waiver of lien from each supplier and sub-contractor covering all items of the work. Failure to supply waivers of lien for the entire job upon completion and final payment request will be considered grounds for withholding final payment.

3. SUBCONTRACTORS

- A. Contractors shall state on the Bid and Award page any and all subcontractors to be associated with their bid, including the type work to be performed. Any and all subcontractors shall be bound by all of the terms, conditions and requirements of the contract; however, the prime contractor shall be responsible for the performance of the total work requirements.
- B. The Contractor shall cooperate with the City of Kalamazoo in meeting its commitments and goals with regard to maximum utilization of minority and women business enterprise, and shall use its best efforts to ensure that minority and women business enterprises have maximum practicable opportunity to compete for subcontract work under this agreement.

SECTION V
GENERAL PROVISIONS

1. INTENT

It is the intent of these plans and specifications to provide for a general contractor who shall provide all labor, materials, tools and equipment necessary to perform in a professional manner for the Michikal, Westnedge, and Kalamazoo Avenue Temporary Traffic Signal project as described in the specifications, plans, and bid document.

2. SCOPE OF WORK

The work will consist of removing and/or salvaging existing traffic signal infrastructure, installing a new wood pole, span wire, and other traffic signal components along with salvaged equipment to place a temporary traffic signal in service at the Kalamazoo Avenue and Westnedge Avenue intersection. A pedestrian crosswalk and associated infrastructure will be installed on the west leg of the intersection.

The bidder shall furnish all labor, supervision, supplies, tools, equipment and other means necessary or proper for performing and completing the work. The bidder shall be responsible for cleaning up of the job site and shall repair or restore all structures and property that may be damaged or disturbed during performance of the work to the satisfaction of the Public Services Department for the City of Kalamazoo. Further details and information on the scope of the project and items therein can be found in the plan set and the specifications.

3. QUANTITIES

The quantities shown or indicated on the plans are only estimated. Payment will be made for the full and complete work based upon the lump sum bid.

4. UNIT PRICING

The unit price, including its pro-rata share of overhead, multiplied by the quantity shown shall represent the total bid and shall be held firm for the life of this contract. Any bid not conforming to this requirement may be rejected as non-responsive.

5. INSPECTION OF WORK

The City may maintain inspectors on the job who shall at all times have access to work.

6. INSPECTION OF SITE

Each bidder shall visit the site of the proposed work and fully acquaint himself/herself with the existing conditions relating to construction and labor and shall fully inform himself/herself as to the facilities involved and the difficulties and restrictions attending the performance of this contract. The bidder shall thoroughly examine and become familiar with the drawings, specifications, and all other bid/contract documents. The Contractor, by the execution of this contract, shall in no way be relieved of any obligation under it due to his/her failure to receive or examine any form or legal instrument, or to visit the site and acquaint himself/herself with the conditions there existing. No allowance shall be made subsequently in this connection in behalf of the Contractor for any negligence of his/her part. For inspection call the Public Services Department, Water Resources Division.

7. INSPECTION AND TESTING

The Contractor shall give the City's Project Manager (Project Manager) timely notice of readiness of the work for all required inspections, tests or approvals, and shall cooperate with inspections and testing personnel to facilitate required inspections or tests. Verification that testing required by the contract has been completed on one phase of the project prior to proceeding to the next phase is the responsibility of the Contractor. In the event that the project has proceeded without required testing, the Contractor shall insure that the required testing is obtained retroactively and shall provide access for testing as necessary at his/her sole expense.

8. MATERIALS INSPECTION AND RESPONSIBILITY

8.1 The Project Manager shall have the right to inspect any materials to be used in carrying out the terms of the contract.

8.2 The City does not assume any responsibility for the contracted quality and standard of all materials, equipment, components or completed work furnished under this contract.

8.3 Any materials, equipment, components or completed work which does not comply with contract specifications, MDOT, or State codes may be rejected by the City, and shall be replaced by the Contractor at no cost to the City.

8.4 Any materials, equipment or components rejected shall be removed within a reasonable period of time from the premises of the City at the entire expense of the Contractor after notice has been given by the City to the Contractor that such materials, equipment or components have been rejected.

9. LAYING OUT WORK

Before submitting a bid the Contractor shall verify all measurements and shall be responsible for the correctness of same. No extra charge or compensation will be allowed on account of differences between actual dimensions and the measurements indicated on the drawings. Any difference that may be found shall be submitted to the City Engineer for consideration before proceeding. The City Engineer will provide staking for the project.

10. SUPERVISION

The Contractor shall employ an experienced superintendent or foreperson on the job at all times.

11. TEMPORARY UTILITIES

11.1 Temporary or construction water will NOT be available on the sites. The Contractor must provide for drinking water.

11.2 Temporary toilets: To be supplied by the Contractor as may be necessary.

12. SITE SECURITY

The Contractor shall be responsible for job site security of all materials and tools provided by him/her and no claim for loss or damage will be considered by the City.

13. TARDINESS

Construction delays resulting from tardiness on the part of the Contractor will be reviewed by the City in the event of any request for contract extension by the Contractor.

14. PROGRESS SCHEDULE

- 14.1 After receipt of Notice to Proceed, work shall start within 10 days unless otherwise agreed to by the Project Manager.
- 14.2 **Work shall have a final completion date on or before October 1, 2025.**
- 14.3 Work of a similar nature may be added to this contract if agreed to by the City and the Contractor. In the event that work is added, the progress schedule for the work will remain unchanged. Any contract time added for additional work will be applied to that additional work only, and cannot be added to items in the original contract. Any work done on the items in the original contract past the number of working days stated herein will be subject to liquidated damages regardless of any work that may be added at a later date.
- 14.4 The Contractor will be required to meet with the Public Services representatives to work out detailed progress schedule. The schedule for this meeting will be within two weeks after contract award has been made.
- 14.5 The named sub-contractor(s) for all items shall also be present at the scheduled meeting and they will be required to sign the Progress Schedule to indicate their approval of the scheduled dates of work set forth in the Progress Schedule.
- 14.6 The Progress Schedule shall include, as a minimum, the starting and completion dates for major items, and where specified in the bid document the date the project is to be opened to traffic as well as the final project completion date specified in the bid documents. The Progress Schedule shall be coordinated with all aspects of the work occurring at the site.
- 14.7 Failure on the part of the Contractor to carry out the provisions of the Progress Schedule as established may be considered sufficient cause to prevent bidding future projects until a satisfactory rate of progress is again established.
- 14.8 The starting date and the contract time to the completion date for this project may be adjusted by Public Services without imposing liquidated damages upon the receipt of satisfactory documented evidence that unforeseen delayed delivery of critical materials will prevent the orderly prosecution of the work.

15. CONSTRUCTION SCHEDULE AND COORDINATION

- 15.1 The Contractor shall supply the City with an agreeable construction schedule before commencing work on this contract. This schedule shall detail beginning and completion dates for each major component of the project.
- 15.2 The Contractor shall coordinate and cooperate with all other contractors who may be working on the site in order to allow for the orderly progress of work being done.
- 15.3 The Contractor is required to keep the Project Manager fully informed of any proposed work which will tend to interfere with the existing operations at the site.
- 15.4 The Contractor shall schedule all work to accommodate the City's schedule. In the event Contractor's schedule falls on weekends, nights or overtime work is required, no additional compensation will be allowed. All work shall be part of this contract without regard to when it is done.
- 15.5 The Contractor shall not schedule work on City-observed holidays.

16. **CONTRACTOR COORDINATION**

- 16.1 The Contractor shall make every effort to coordinate every aspect of his work with that of other contractors on the site to assure an efficiently managed and proper installation.
- 16.2 Consideration shall be given to timing of construction, maintaining adequate construction access, and construction staging. Any costs associated with this coordination shall be included in the contract.

17. **COORDINATING CLAUSE**

The Contractor's attention is called to 104.08 of the MDOT 2020 Standard Specifications for Construction entitled "Cooperation by Contractor."

18. **ADDITIONS**

- 18.1 Any modification to the contract shall be subject to prior approval by the Purchasing Agent. City Commission approval may also be required.
- 18.2 Prices for additional work required are not requested in the itemized listing contained herein for the base project. Should additional work be authorized, compensation shall be made on the basis of price or prices to be mutually agreed upon. Such additional work shall not begin until approved.

19. **MAINTAINING TRAFFIC**

- 19.1 This work shall be in accordance with the requirements of Section 812 of the MDOT Standard Specifications for Construction and as specified herein. The Contractor is advised that the current Michigan Manual of Uniform Traffic Control Devices is hereby established as governing all work in connection with traffic control devices, barricade lighting, etc. required on this project.
- 19.2 The Contractor shall furnish, erect, maintain and, upon completion of the work, remove all traffic control devices and barricade lights within the project and around the perimeter of the project for the safety and protection of through and local traffic. This includes, but is not limited to: Advance, regulatory and warning signs; barricades and channeling devices at intersecting streets on which traffic is to be maintained; barricades at the ends of the project and at right-of-way lines for intersecting streets which are to be closed with the first usable street on each side of the project. Traffic regulators, where required by the Engineer, are included.
- 19.3 Where the existing pavement or partial widths of new pavement are to be utilized for the maintenance of through and local traffic, drum type barricades will be required at 50' intervals or as directed by the Engineer for channeling and directing traffic through the construction area.
- 19.4 Through traffic shall be maintained utilizing sidewalk closures with detours and traffic shifts per MDOT traffic and safety details.
- 19.5 Protection of all pedestrian traffic shall be maintained at all times.
- 19.6 Payment for the traffic control devices shall be based on the contract lump sum price.
- 19.7 Under Article 812.04.D "Operated Pay Items" the term 'Relocating' shall include the relocating of the item from any street covered by the contract to any other street covered by the contract.

Special Restrictions: Access to frontage properties shall be maintained as much as practical. Emergency access shall be maintained at all times. The Contractor shall maintain two-way traffic with flag control as needed when the road is restricted to only one traffic lane.

20. LIQUIDATED DAMAGES

20.1 Liquidated damages, if applicable, shall be \$500.00 a day regardless of contract size.

20.2 The provisions of Article 108.11B of the MDOT 2003 Standard Specifications for Construction for reducing liquidated damages of 50 percent of the amount indicated in Table 108-1 of article 108.11C for projects where traffic is maintained during construction will not apply.

21. REMOVAL OF RUBBISH

The Contractor shall daily remove all rubbish and accumulated materials due to his/her construction.

22. SITE ACCESS

The City will provide fair and reasonable access to the job site within the working schedules of both parties.

23. GUARANTEE

The Contractor shall guarantee all of his/her work for a period of two (2) years following the date of final acceptance of the completed work and shall repair, replace or make good any materials or work which fail to function or perform or be found defective, without cost to the City.

24. SAFETY

The Contractor shall comply with all applicable OSHA and MIOSHA regulations.

25. PAY ESTIMATES

The Contractor shall be responsible for the generation of invoices for payment. Payment will be generated by the City based upon an approved invoice. Recommended frequency of payment is monthly, however, frequency of payment will not exceed bi-weekly.

26. PRODUCT/SYSTEM SUBSTITUTIONS

Submit a written request, to be received not later than 10 days prior to scheduled bid opening, for Substitution of any Product not named. If no substitutions are submitted, it will be reasonably concluded by the Owner and Landscape Architect that the specified product will be incorporated into the Work and the Bidder will be committed to supplying the specified product.

26.1 Describe in detail any variance to the Product specified. All proposed substitution for specified items shall be substantially the same size (height, length, width, diameter, etc.), type, color, construction quality and shall meet the design intent to be considered for substitution for the Product specified.

26.2 Document each request with complete data substantiating compliance of proposed Substitution with Product specified including written certification that Product conforms to or exceeds all requirements of the Product specified.

26.3 Document all coordination information, including a list of changes or modifications needed to the Contract Documents or other parts of the Work and to construction performed by the Owner and Separate Contractors that will become necessary to accommodate the proposed substitution.

26.4 Provide name, address and telephone number of manufacturer's authorized representative.

26.5 Submit three copies of all documents for each request for Substitution for consideration.

26.6 Approval of the Substitution request, if given, will be in the form of an addendum issued prior to scheduled opening date and hour at local time.

27. SAMPLES AND DEMONSTRATIONS

Evidence in the form of samples may be requested. Such samples are to be furnished after the date of bid opening only upon request of The City unless otherwise stated in the bid proposal. If samples should be requested, such samples must be received by The City no later than seven (7) days after formal request is made. When required, The City may request full demonstrations of any unit(s) bid prior to the award of any contract. Samples, when requested, must be furnished free of expense to The City and if not used in testing or destroyed, will upon request within thirty (30) days of bid award be returned at the bidder's request.

28. ACCEPTANCE OF MATERIAL

The material delivered under this proposal shall remain the property of the seller until a physical inspection and actual usage of the material and/or services is made and thereafter accepted to the satisfaction of The City and must comply with the terms herein, and be full in accord with specifications and of the highest quality. In the event the material and/or service supplied to The City is found to be defective or does not conform to specifications, The City reserves the right to cancel the order upon written notice to the seller and return the product to seller at the seller's expense.

29. VARIATIONS TO SPECIFICATIONS

For purposes of evaluation, the bidder **MUST** indicate any variances from our specifications, terms and/or conditions, no matter how slight. If variations are not stated in the proposal, it will be assumed that the product or service fully complies with our specifications, terms and conditions.

30. SAFETY STANDARDS

The bidder warrants that the products supplied to The City conform in all respects to the standards set forth in the Occupational Safety and Health Act of 1970 and its amendments and the failure to comply with this condition will be considered a breach of contract.

31. MANUFACTURER'S CERTIFICATION

The City reserves the right to request from bidders separate manufacturer certification of all statements made in the bid.

32. PROTECTION OF WORK

The Contractor shall maintain adequate protection of all his/her work from damage and shall protect all public and private abutting property from injury or loss arising in connection with this contract.

33. PROTECTION OF PROPERTY

33.1 The Contractor shall confine his/her equipment and operations to those areas of the work site necessary for the completion of the work, or as authorized by the Project Manager. The Contractor shall protect and preserve from damage any facilities, utilities or features including trees, shrubs and turf which are not required to be disturbed by the requirements of the work.

33.2 The Contractor shall be responsible to determine the location of and to protect from damage any utilities or other improvements.

34. **QUESTIONS**

Bidders shall address questions regarding the specifications to Tom Palumbo, Senior Civil Engineer-Public Services at palumbot@kalamazoocity.org. (This does not relieve the requirements of Page 1, Item 3.) Questions regarding terms, conditions and other related bid requirements may be addressed to Scott Shaffer, Buyer at shaffers@kalamazoocity.org or (269) 337-8444.

SECTION VI
TERMS AND CONDITIONS

1. AWARD OF CONTRACT

- A. This contract will be awarded to that responsible bidder whose bid, conforming to this solicitation, will be most advantageous to the City, price and other factors considered. The City reserves the right to accept or reject any or all bids and waive informalities and minor irregularities in bids received. Other factors include, as an example but not limited to, delivery time, conformance to specifications, incidental costs such as demurrage and deposits, etc.

Notification of award will be in writing by the Purchasing Agent. Upon notification, the Contractor shall submit to the Purchasing Division all required insurance certificates (if required) and such other documentation as may be requested or required hereunder. Upon their receipt and subsequent approval by the City, the Purchasing Agent will forward to the Contractor a written **NOTICE TO PROCEED**. Work shall **NOT** be started until such **NOTICE TO PROCEED** is received by the Contractor.

- B. Unilateral changes in bid prices by the bidder shall not be allowed. However, the City, at its sole option, reserves the right to negotiate with bidders in the event of, but not limited to:

- 1) No bids received;
- 2) A single bid being received; or
- 3) Prices quoted are over budget and/or unreasonable.

2. COMPLETE CONTRACT

This bid document together with its addenda, amendments, attachments and modifications, when executed, becomes the complete contract between the parties hereto, and no verbal or oral promises or representations made in conjunction with the negotiation of this contract shall be binding on either party.

3. SUBCONTRACTORS - NON ASSIGNMENT

Bidders shall state in writing any and all sub-contractors to be associated with this bid, including the type of work to be performed. The Contractor shall cooperate with the City of Kalamazoo in meeting its commitments and goals with regard to maximum utilization of minority and women-owned business enterprises.

The Contractor hereby agrees and understands that the contract resulting from this solicitation shall not be transferred, assigned or sublet without prior written consent of the City of Kalamazoo.

4. TAXES

The City of Kalamazoo is exempt from all federal excise tax and state sales and use taxes. However, depending upon the situation, the vendor or contractor may not be exempt from said taxes and the City of Kalamazoo is making no representation as to any such exemption.

5. **INVOICING**

All original invoice(s) will be sent to the Financial Services Division, 241 W. South Street, Kalamazoo, MI 49007 or via email at apinvoice@kalamazoocity.org. The Finance Division processes payments after receipt of an original invoice from the Contractor and approval by the department. The City of Kalamazoo's policy is to pay invoice(s) within 30 days from the receipt of the original invoice, if the services or supplies are satisfactory and the proper paperwork and procedures have been followed. **In order to guarantee payment to the vendor on a timely basis, the vendor needs to receive a purchase order number before supplying the City of Kalamazoo with goods or services.** All original, and copies of original invoice(s), will clearly state which purchase order they are being billed against.

The City of Kalamazoo is a government municipality and therefore is tax exempt from all sales tax.

The vendor is responsible for supplying the Finance Division with a copy of their W9 if they are providing a service to the City of Kalamazoo.

6. **PAYMENTS**

Upon issuance of certificates of Payment by the Architect/Engineer for labor and material incorporated in the work and the materials suitably stored at the site payment shall be made up to ninety (90%) percent of the value thereof.

When the cumulative total of payment is equal to fifty (50%) percent of the contract sum, subsequent payments will be made in the full amount for labor and material certified by the Architect/Engineer.

The amount retained shall be held until final acceptance of the work, receipt of all payrolls, releases, and waiver of liens.

7. **CHANGES AND/OR CONTRACT MODIFICATIONS**

The City reserves the right to increase or decrease quantities, service or requirements, or make any changes necessary at any time during the term of this contract, or any negotiated extension thereof. Price adjustments due to any of the foregoing changes shall be negotiated and mutually agreed upon by the Contractor and the City.

Changes of any nature after contract award which reflect an increase or decrease in requirements or costs shall not be permitted without prior approval by the Purchasing Agent. City Commission approval may also be required. **SUCH CHANGES, IF PERFORMED IN ADVANCE OF PURCHASING AGENT APPROVAL, MAY BE SUBJECT TO DENIAL AND NON-PAYMENT.**

8. LAWS, ORDINANCES AND REGULATIONS

The Contractor shall keep himself/herself fully informed of all local, state and federal laws, ordinances and regulations in any manner affecting those engaged or employed in the work and the equipment used. Contractor and/or employees shall, at all times, serve and comply with such laws, ordinances and regulations.

Any permits, licenses, certificates or fees required for the performance of the work shall be obtained and paid for by the Contractor.

This contract shall be governed by the laws of the State of Michigan.

9. RIGHT TO AUDIT

The City or its designee shall be entitled to audit all of the Contractor's records, and shall be allowed to interview any of the Contractor's employees, throughout the term of this contract and for a period of three years after final payment or longer if required by law to the extent necessary to adequately permit evaluation and verification of:

- A. Contractor compliance with contract requirements,
- B. Compliance with provisions for pricing change orders, invoices or claims submitted by the Contractor or any of his payees.

10. HOLD HARMLESS

If the acts or omissions of the Contractor/Vendor or its employees, agents or officers, cause injury to person or property, the Contractor/Vendor shall defend, indemnify and save harmless the City of Kalamazoo, their agents, officials, and employees against all claims, judgments, losses, damages, demands, and payments of any kind to persons or property to the extent occasioned from any claim or demand arising therefrom.

11. DEFAULT

The City may at any time, by written notice to the Contractor, terminate this contract and the Contractor's right to proceed with the work, for just cause, which shall include, but is not limited to the following:

- A. Failure to provide insurance and bonds (when called for), in the exact amounts and within the time specified or any extension thereof.
- B. Failure to make delivery of the supplies, or to perform the services within the time specified herein, or any extension thereof.
- C. The unauthorized substitution of articles for those bid and specified.
- D. Failure to make progress if such failure endangers performance of the contract in accordance with its terms.
- E. Failure to perform in compliance with any provision of the contract.

DEFAULT (cont.)

- F. **Standard of Performance** - Contractor guarantees the performance of the commodities, goods or services rendered herein in accordance with the accepted standards of the industry or industries concerned herein, except that if this specification calls for higher standards, then such higher standards shall be provided.

Upon notice by the City of Contractor's failure to comply with such standards or to otherwise be in default of this contract in any manner following the Notice to Proceed, Contractor shall immediately remedy said defective performance in a manner acceptable to the City. Should Contractor fail to immediately correct said defective performance, said failure shall be considered a breach of this contract and grounds for termination of the same by the City.

In the event of any breach of this contract by Contractor, Contractor shall pay any cost to the City caused by said breach including but not limited to the replacement cost of such goods or services with another Contractor.

The City reserves the right to withhold any or all payments until any defects in performance have been satisfactorily corrected.

In the event the Contractor is in breach of this contract in any manner, and such breach has not been satisfactorily corrected, the City may bar the Contractor from being awarded any future City contracts.

- G. All remedies available to the City herein are cumulative and the election of one remedy by the City shall not be a waiver of any other remedy available to the City.

12. TERMINATION OF CONTRACT

The City may, at any time and without cause, suspend the work of this contract for a period of not more than ninety days after providing notice in writing to the Contractor. The Contractor shall be allowed an adjustment in the contract price or an extension of the contract times, or both, directly attributable to the suspension if Contractor makes an approved claim.

The City may, without prejudice to any other right or remedy of the City, and with or without cause, terminate the contract by giving seven days written notice to the Contractor. In such case the Contractor shall be paid, without duplication, for the following items:

- A. Completed and acceptable work executed in accordance with the contract documents prior to the effective date of termination, including fair and reasonable sums for overhead and profit on such work;
- B. Expenses sustained prior to the effective date of termination in performing services and furnishing labor, materials or equipment as required by the contract documents in connection with uncompleted work, plus fair and reasonable sums for overhead and profit on such expenses;
- C. All documented claims, costs, losses and damages incurred in settlement of terminated contracts with Subcontractors, Suppliers and others; and
- D. Reasonable expenses directly attributable to termination.

The Contractor shall not be paid on account of loss of anticipated profits or revenue or other economic loss arising out of or resulting from such termination.

13. INDEPENDENT CONTRACTOR

At all times, the Contractor, any of his/her employees, or his/her sub-contractors and their subsequent employees shall be considered independent contractors and not as City employees. The Contractor shall exercise all supervisory control and general control over all workers' duties, payment of wages to Contractor's employees and the right to hire, fire and discipline their employees and workers. As an independent contractor, payment under this contract shall not be subject to any withholding for tax, social security or other purposes, nor shall the Contractor or his/her employees be entitled to sick leave, pension benefit, vacation, medical benefits, life insurance or workers' unemployment compensation or the like.

14. PROJECT SUPERVISOR

The Contractor shall employ an individual to act as Project Supervisor. The Project Supervisor shall be available to the Contractor's workers and the Project Manager at all times by use of a beeper or other reliable means. The Project Supervisor shall prepare daily work plans for the employees, monitor employee performance, attendance and punctuality; and work closely with the City's Project Manager in assuring contract compliance.

15. MEETINGS

The Contractor and/or Project Supervisor shall be available to meet with the Department Head or Project Manager at a mutually agreeable time to discuss problems, issues or concerns relative to the contract. Either party may call a meeting at any time. When such a request for a meeting is made, the meeting date shall, in no case exceed five (5) working days after the request; and, if in the sole opinion of the Department Head, the severity of the circumstance warrants, no more than one (1) working day.

16. INSPECTION OF WORK SITE

Before submitting bids or quotes for work, the Contractor shall be responsible for examining the work site and satisfying himself/herself as to the existing conditions under which he/she will be obligated to operate, or that in any way affects the work under this contract. No allowance shall be made subsequently, on behalf of the Contractor, for any negligence on his/her part.

17. CONTRACT PERIOD, EXTENSIONS, CANCELLATION

- A. The contract shall be in effect for the term stated in the specifications.
- B. The City may opt to extend this contract upon mutual agreement of both parties. The number of extensions shall be limited to that stated in the specifications.
- C. The City may, from time to time, find it necessary to continue this contract on a month-to-month basis only, not to exceed a six (6) month period. Such month-to-month extended periods shall be by mutual agreement of both parties, with all provisions of the original contract or any extension thereof remaining in full force and effect.
- D. All contracts, extensions and cost increases are subject to availability of funds and the approval of the City Commission (if required).

CONTRACT PERIOD, EXTENSIONS, CANCELLATION (*cont.*)

- E. The City reserves the right to cancel the contract due to non-appropriation of funds by the City with thirty (30) days written notice.
- F. Either party may terminate the contract (or any extension thereof) without cause at the end of any twelve (12) month term by giving written notice of such intent at least 60 days prior to the end of said twelve (12) month term.
- G. All notices are in effect commencing with the date of mailing. Written notices may be delivered in person or sent by First Class mail; faxed or emailed to the last known address.
- H. If cancellation is for default of contract due to non-performance, the contract may be canceled at any time (see Item 11, DEFAULT)

APPENDIX A
NON-DISCRIMINATION CLAUSE FOR ALL CITY OF KALAMAZOO CONTRACTS

The Contractor agrees to comply with the Federal Civil Rights Act of 1964 as amended; the Federal Civil Rights Act of 1991 as amended; the Americans With Disabilities Act of 1990 as amended; the Elliott-Larson Civil Rights Act, Act. No. 453, Public Act of 1976 as amended; the Michigan Handicappers Civil Rights Act, Act No. 220, Public Act of 1976 as amended, City Ordinance 1856 and all other applicable Federal and State laws. The Contractor agrees as follows:

1. The Contractor will not discriminate against any employee or applicant for employment because of race, color, religion, national origin, sex, age, height, weight, marital status, physical or mental disability, family status, sexual orientation or gender identity that is unrelated to the individual's ability to perform the duties of the particular job or position. Such action shall include, but not be limited to the following: employment, upgrading, demotion or transfer, recruitment advertising, layoff or termination; rates of pay or other forms of compensations; and selection for training, including apprenticeship.
2. The Contractor will, in all solicitations or advertisements for employees placed by or on behalf of the Contractor, state that all qualified applicants will receive consideration for employment without regard to race, color, religion, national origin, sex, age, height, weight, marital status, physical or mental disability family status, sexual orientation or gender identity that is unrelated to the individual's ability to perform the duties of the particular job or position.
3. If requested by the City, the Contractor shall furnish information regarding practices, policies and programs and employment statistics for the Contractor and subcontractors. The Contractor and subcontractors shall permit access to all books, records and accounts regarding employment practices by agents and representatives of the City duly charged with investigative duties to assure compliance with this clause.
4. Breach of the covenants herein may be regarded as a material breach of the contract or purchasing agreement as provided in the Elliott-Larsen Civil Rights Act and City Ordinance 1856.
5. The Contractor will include or incorporate by reference the provisions of the foregoing paragraphs 1 through 4 in every subcontract or purchase order unless exempted by the rules, regulations or orders of the Michigan Civil Rights Commission* and will provide in every subcontract or purchase order that said provision will be binding upon each subcontractor or seller.
6. The Contractor will not preclude a person with a criminal conviction from being considered for employment unless otherwise precluded by federal or state law. (for contracts over \$25,000)

The Elliott-Larson Civil Rights Act, Sec. 202 of Act. No. 453 of 1976 reads in part as follows:

Sec. 202. (1) An employer shall not:

- (a) Fail or refuse to hire, or recruit, or discharge or otherwise discriminate against an individual with respect to employment, compensation, or a term condition or privilege of employment because of religion, race, color, national origin, age, sex, height, weight or marital status.
- (b) Limit, segregate or classify an employee or applicant for employment in a way which deprives or tends to deprive the employee or applicant of an employment opportunity or otherwise adversely affects the status of an employee or applicant because of religion, race, color, national origin, age, sex, height, weight or marital status.
- (c) Segregate, classify or otherwise discriminate against a person on the basis of sex with respect to a term, condition or privilege of employment, including a benefit plan or system.

* Except for contracts entered into with parties employing less than three employees.



PLANS

Michikal-Kalamazoo-Westnedge Signal

Bid Reference #: 96880-006.0

July 2025

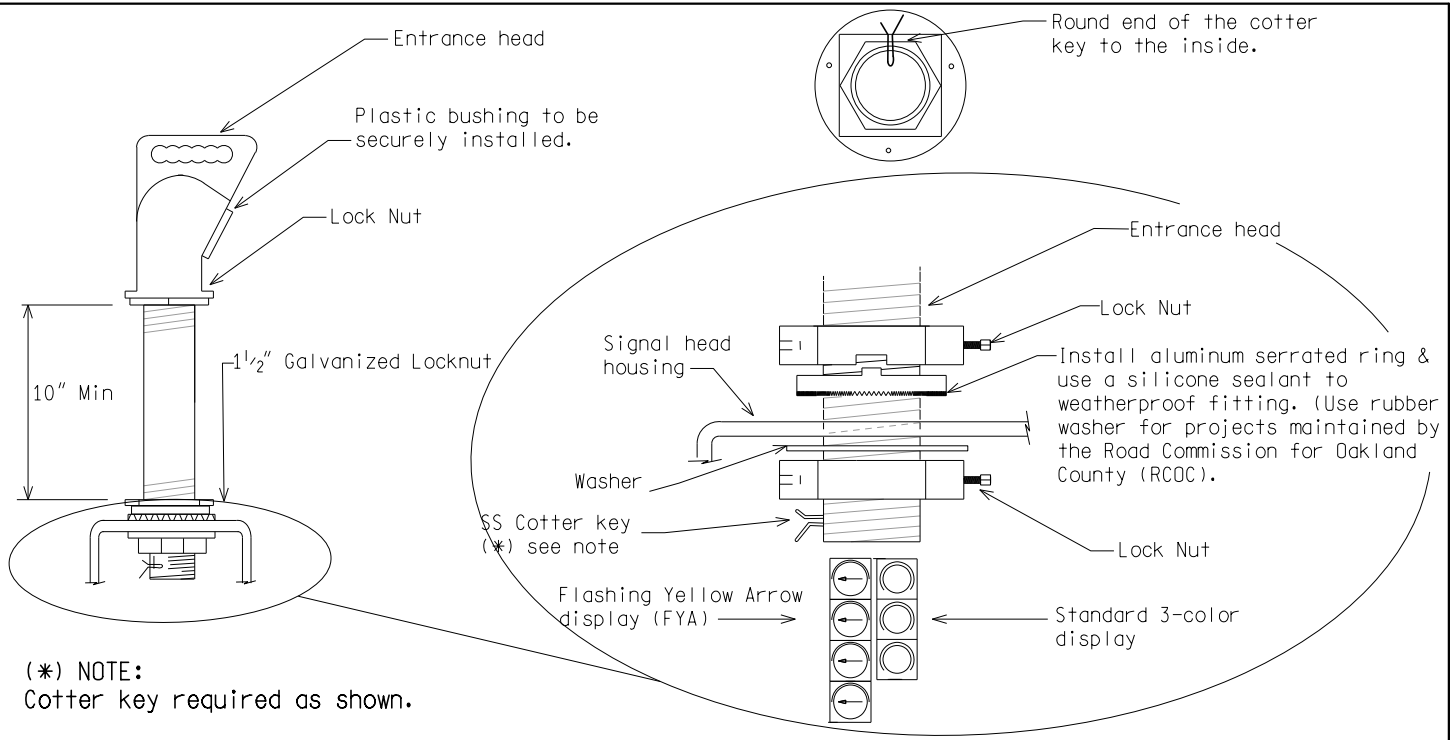

(* NOTE:
Cotter key required as shown.

ONE-WAY TRAFFIC SIGNAL HEAD

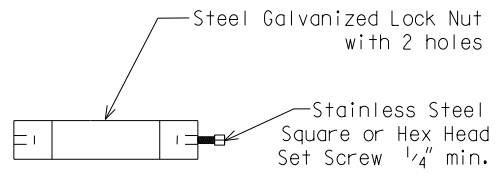

OH SIGNAL LOCK NUT DETAIL

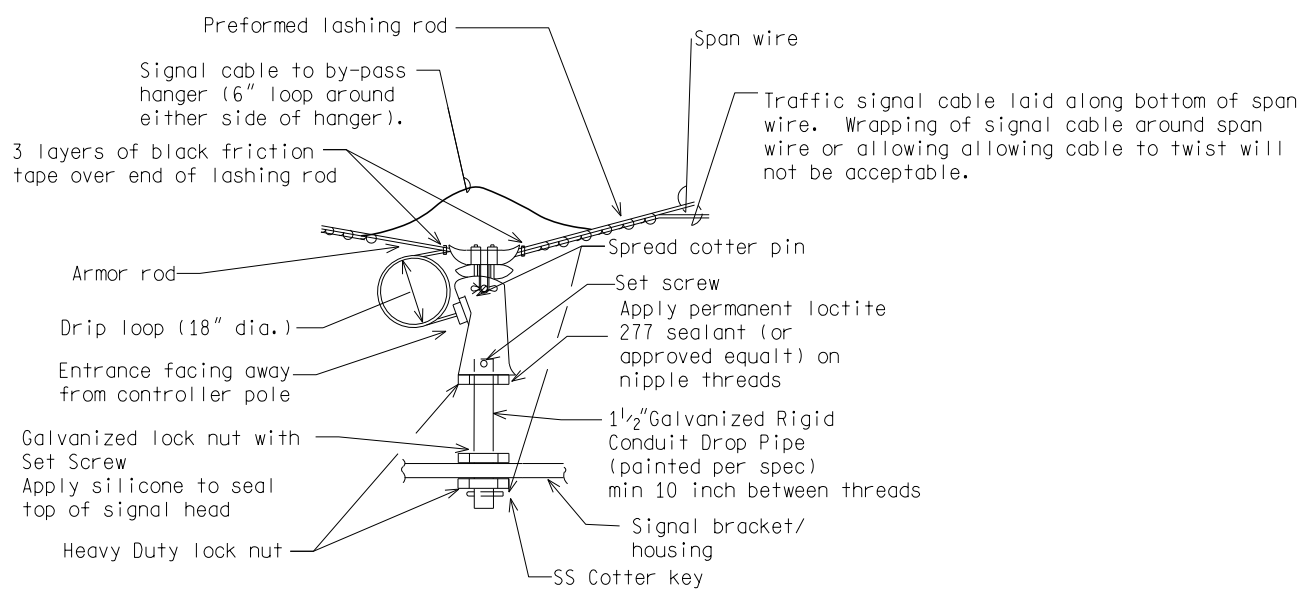

HANGER ATTACHMENT

NOT TO SCALE

File: RefDoc/TR/Signals/Web/Sp Det/Fin/SIG300A.dgn Rev. 11/13/20



PREPARED BY
TRAFFIC AND SAFETY

DRAWN BY: DJF

CHECKED BY:

ENGINEER OF DELIVERY

ENGINEER OF DEVELOPMENT

(SPECIAL DETAIL)

FHWA APPROVAL DATE

MICHIGAN DEPARTMENT OF TRANSPORTATION
BUREAU OF HIGHWAYS DELIVERY STANDARD PLAN FOR

**SPAN WIRE MOUNTED
T.S. BRACKET ASSEMBLY**

PLAN DATE

SIG-300-A

SHEET
1 of 3

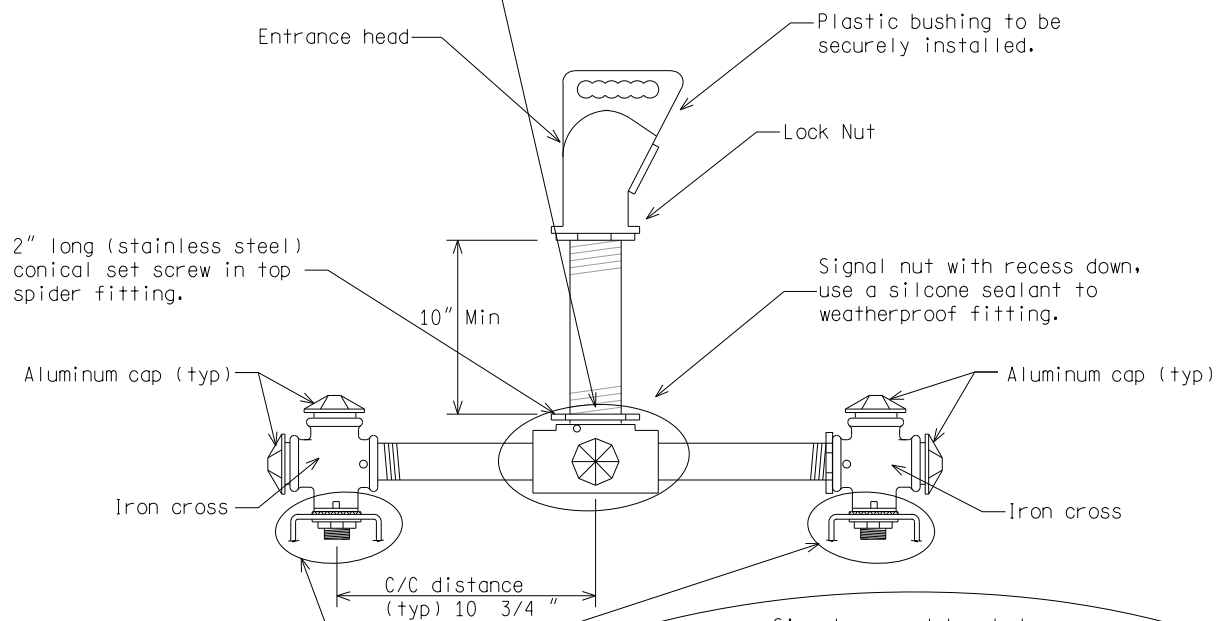
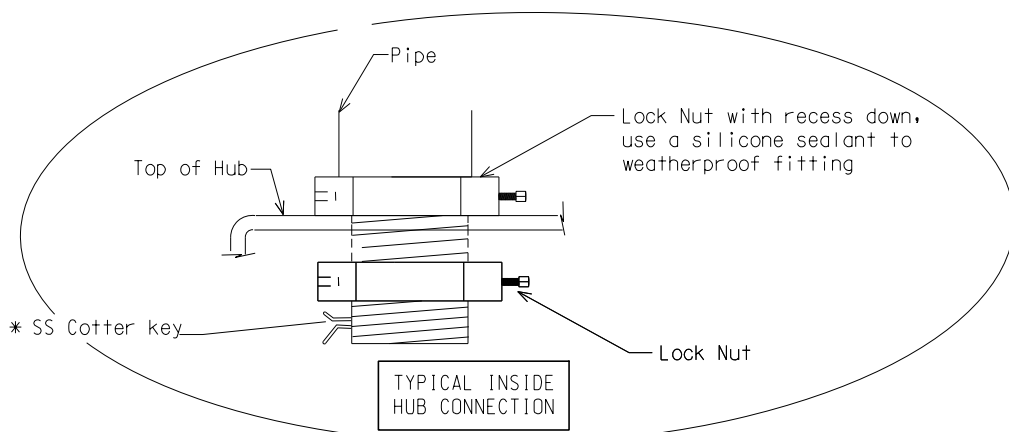

NOTE:
2-way T.S. shown
3-way T.S. & 4-way similar

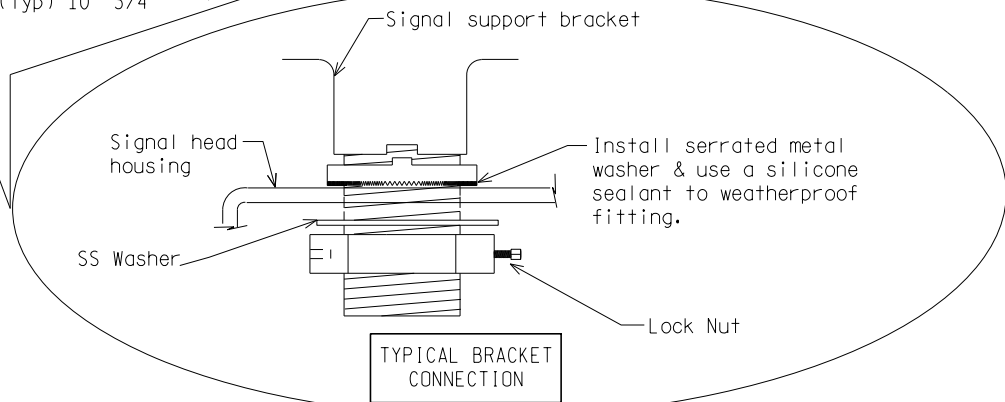

MULTIPLE-WAY TRAFFIC SIGNAL HEAD(S)

- NOTE:
- 1) Exterior surface of all mounting assemble located below span clamps, including stems, lock nuts, and related hardware must match the current FHWA Highway yellow color tolerance chart per the Standard Specifications for Construction.
 - 2) Tolerance within $\pm 1/8"$ for all bracketing.

NOT TO SCALE

MICHIGAN DEPARTMENT OF TRANSPORTATION
BUREAU OF HIGHWAYS DELIVERY STANDARD PLAN

(SPECIAL DETAIL)
FHWA APPROVAL DATE

PLAN DATE

SIG-300-A

SHEET
2 of 3

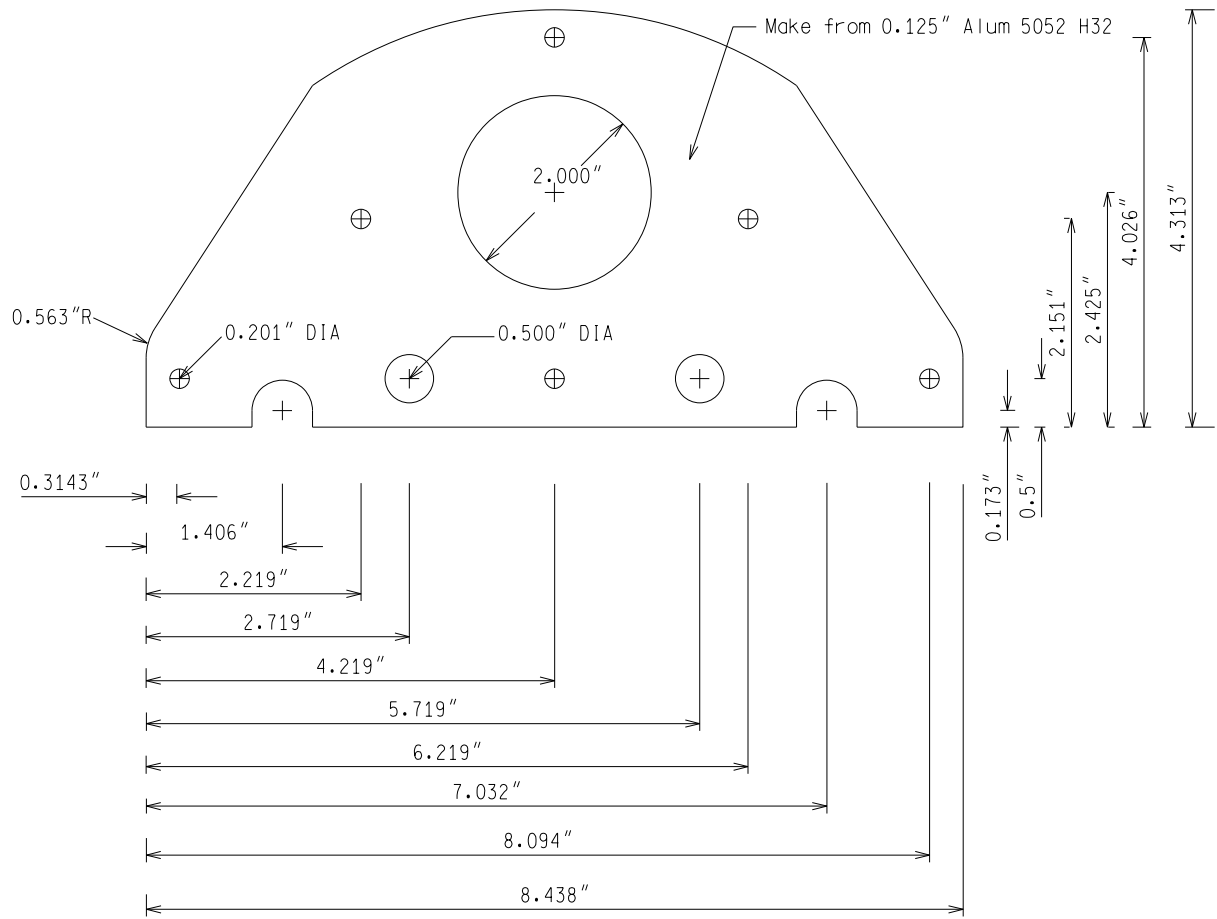

INSIDE SIGNAL HOUSING

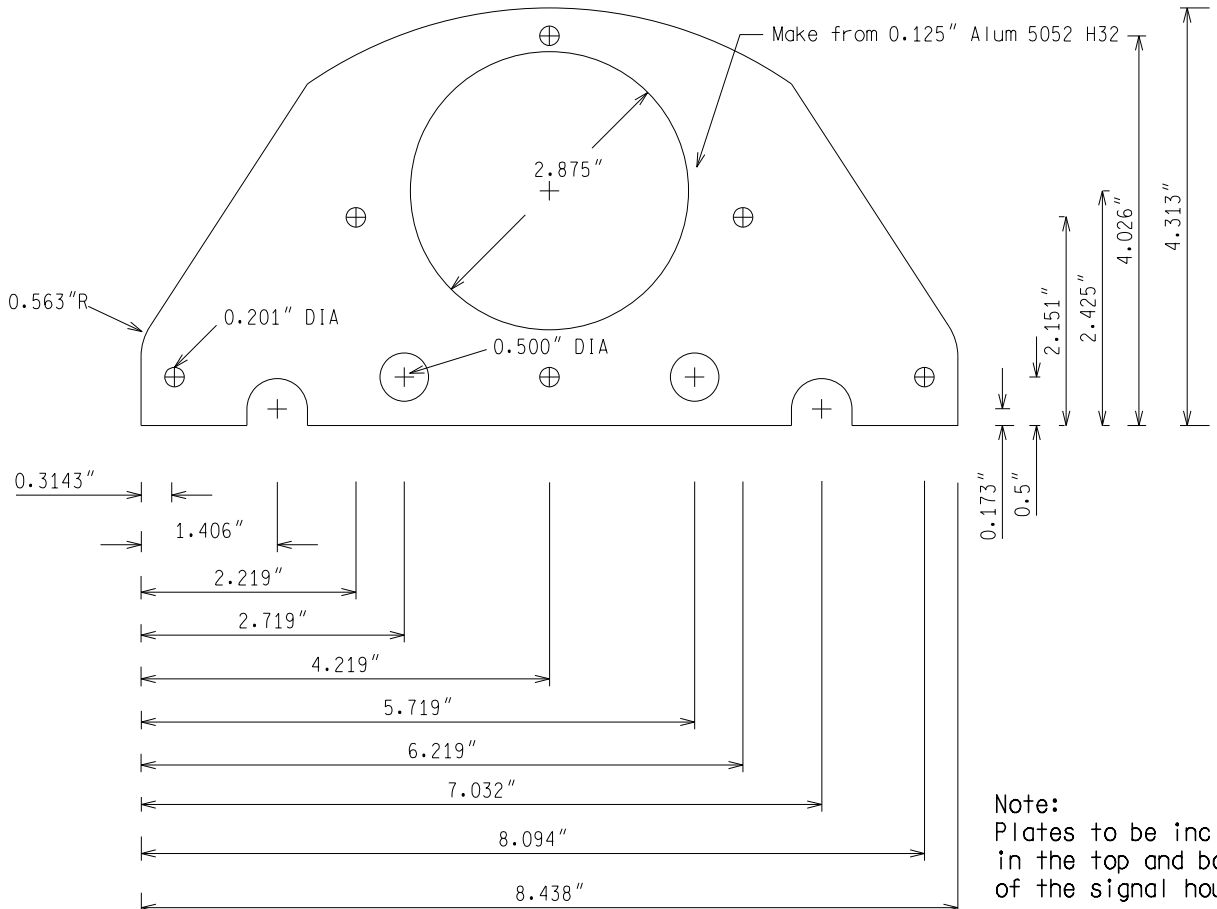

OUTSIDE SIGNAL HOUSING

Note:
Plates to be included
in the top and bottom
of the signal housing.

NOT TO SCALE

* MAXIMUM LANDING SLOPE IS 2.1% IN EACH DIRECTION OF TRAVEL. LANDING MINIMUM DIMENSIONS 5' x 5'. SEE NOTES.

** MAXIMUM RAMP CROSS SLOPE IS 2.1%, RUNNING SLOPE 5% - 7% (8.3% MAXIMUM). SEE NOTES.

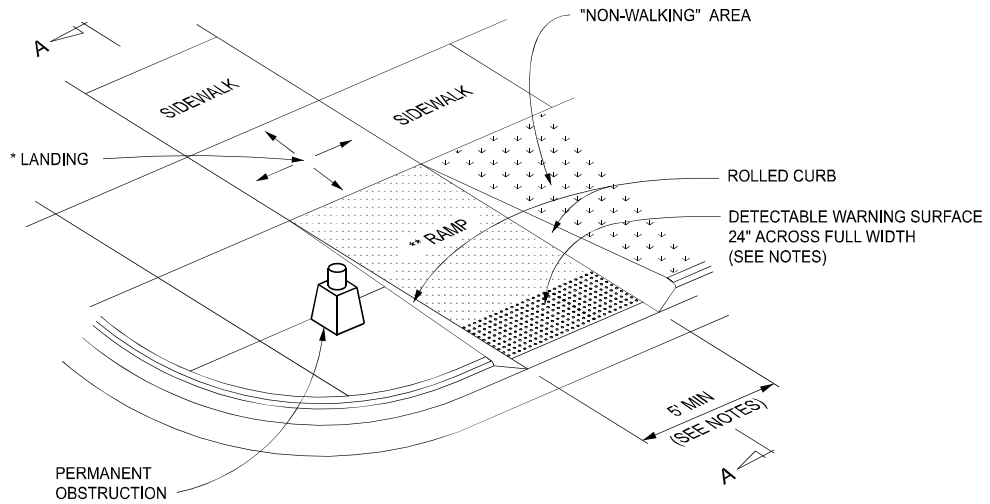

CURB RAMP TYPE R
(ROLLED SIDES)

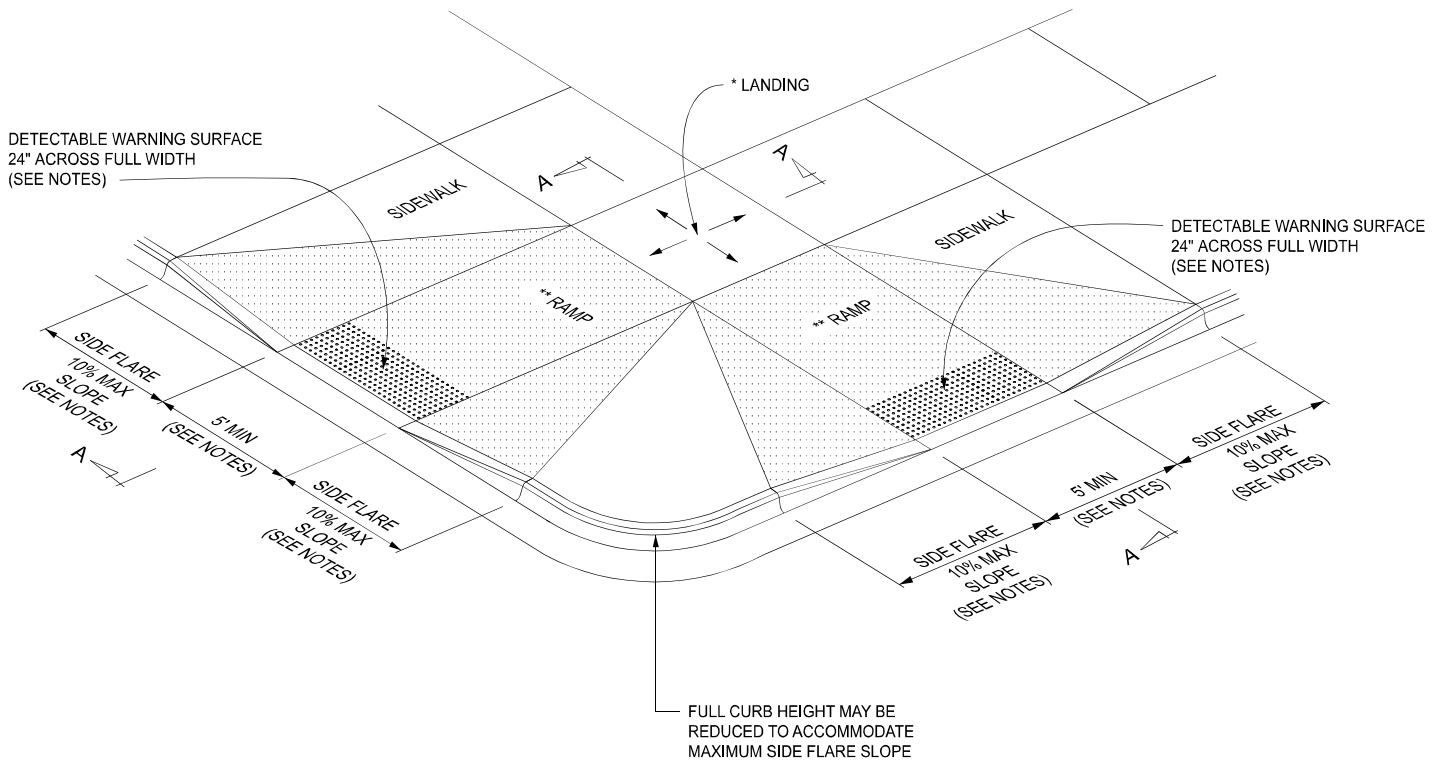

CURB RAMP TYPE F
(FLARED SIDES, TWO RAMPS SHOWN)

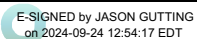
APPROVED BY:  E-SIGNED by JASON GUTTING
on 2024-09-24 12:54:17 EDT
DIRECTOR, BUREAU OF FIELD SERVICES

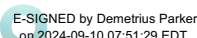
APPROVED BY:  E-SIGNED by Demetrius Parker
on 2024-09-10 07:51:29 EDT
DIRECTOR, BUREAU OF DEVELOPMENT



DEPARTMENT DIRECTOR
BRADLEY C. WIEFERICH, PE

STANDARD PLAN FOR
CURB RAMP AND
DETECTABLE WARNING DETAILS

12/18/2024
FHWA APPROVAL

06/21/2014
PLAN DATE

R-28-K

SHEET
1 OF 7

* MAXIMUM LANDING SLOPE IS 2.1% IN EACH DIRECTION OF TRAVEL. LANDING MINIMUM DIMENSIONS 5' x 5'. SEE NOTES.

** MAXIMUM RAMP CROSS SLOPE IS 2.1%, RUNNING SLOPE 5% - 7% (8.3% MAXIMUM). SEE NOTES.

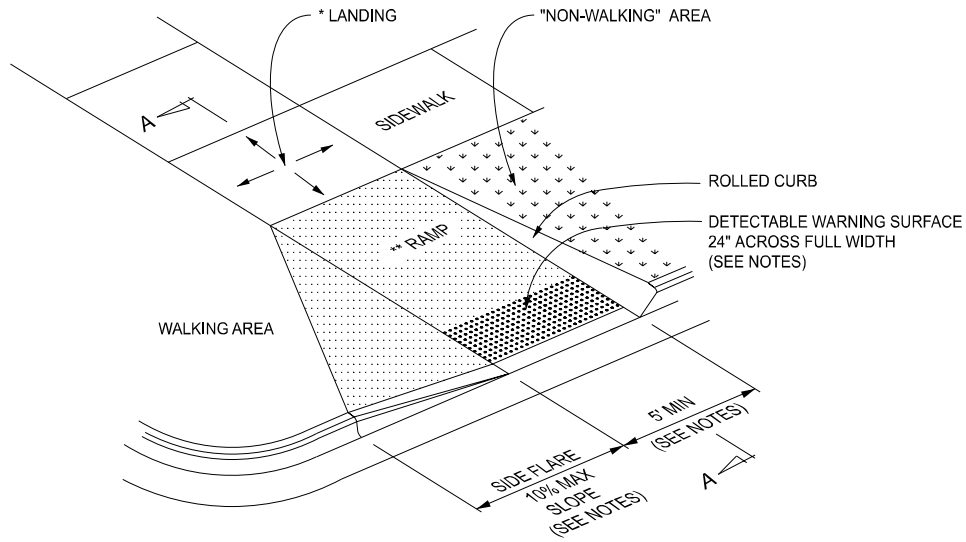

CURB RAMP TYPE RF
(ROLLED / FLARED SIDES)

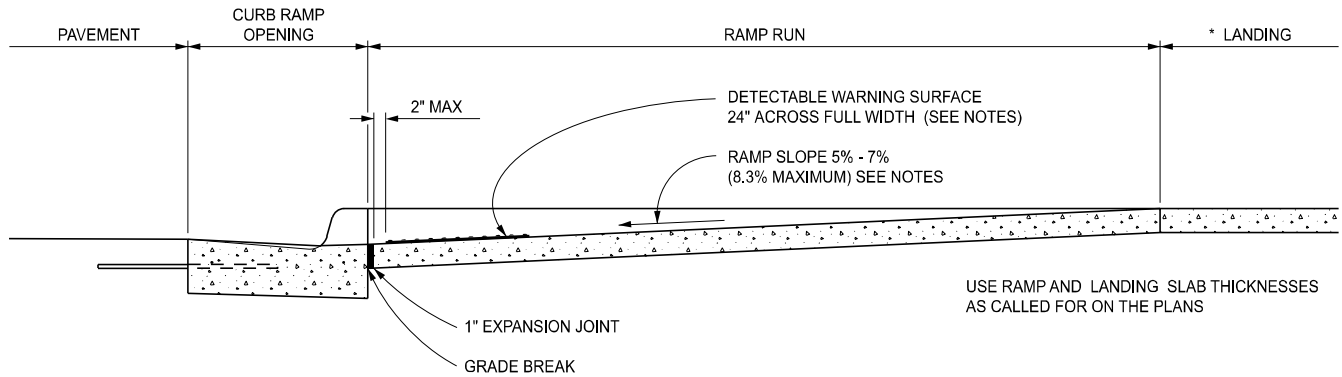

SECTION A-A

CURB TYPE	MAXIMUM RISE (INCHES)	
	A	B
B1	¾	1
B2	¾	1
B3	¾	1
D1	¾	1
D2	¾	1
D3	¾	1
C1	½	½
C2	½	½
C3	¾	½
C4	¾	½
C5	1	½
C6	1	½
F1	½	½
F2	½	½
F3	¾	½
F4	¾	½
F5	1	½
F6	1	½

FOR CURB TYPES SEE STANDARD PLAN R-30-SERIES

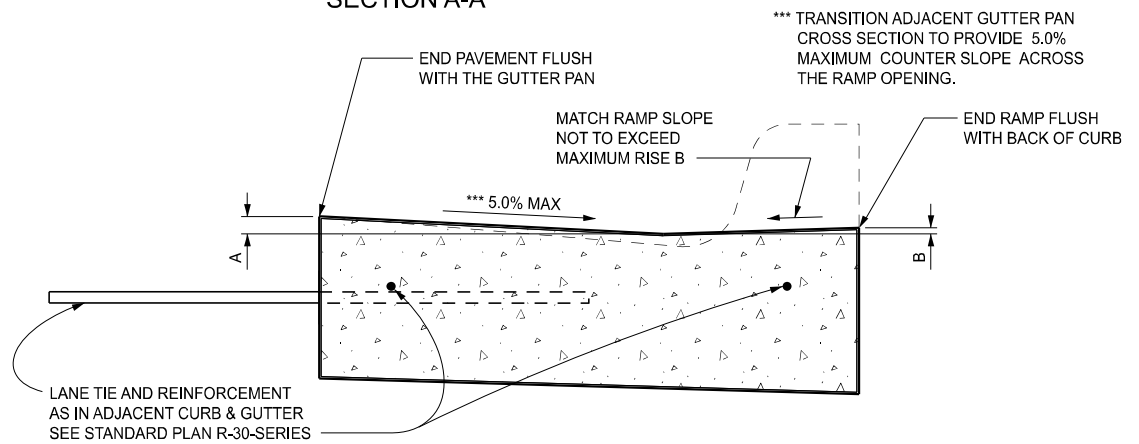

SECTION THROUGH CURB RAMP OPENING
(TYPICAL ALL RAMP TYPES)

 DEPARTMENT DIRECTOR BRADLEY C. WIEFERICH, PE	STANDARD PLAN FOR CURB RAMP AND DETECTABLE WARNING DETAILS		R-28-K	SHEET 2 OF 7
	12/18/2024 FHWA APPROVAL	06/21/2014 PLAN DATE		

* MAXIMUM LANDING SLOPE IS 2.1% IN EACH DIRECTION OF TRAVEL. LANDING MINIMUM DIMENSIONS 5' x 5'. SEE NOTES.

** MAXIMUM RAMP CROSS SLOPE IS 2.1%, RUNNING SLOPE 5% - 7% (8.3% MAXIMUM). SEE NOTES.

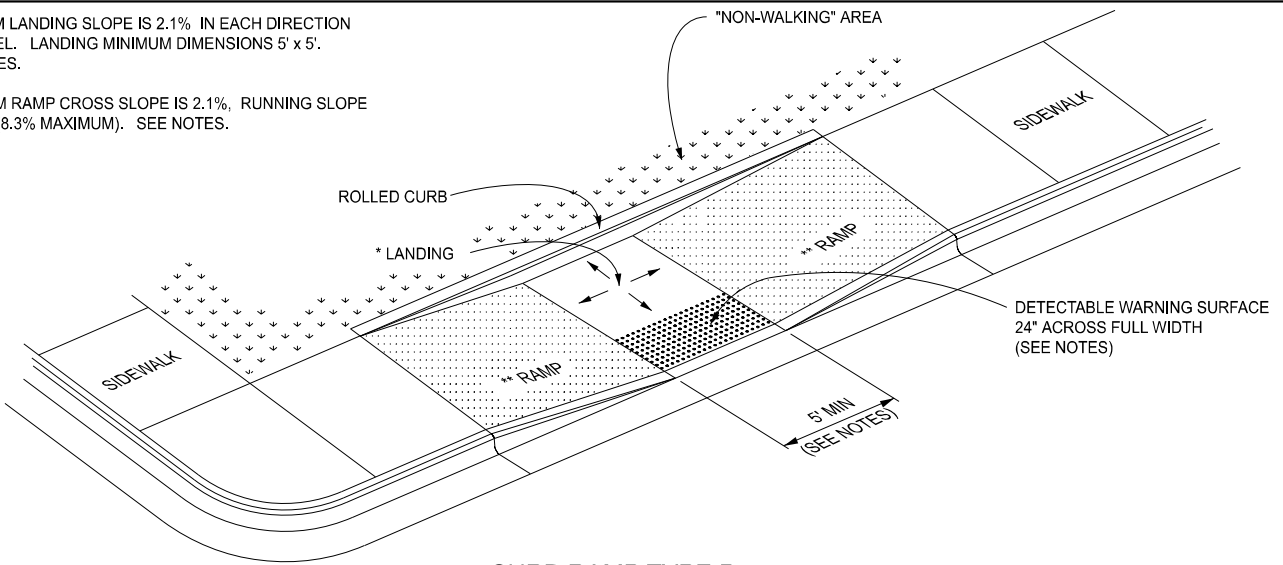

CURB RAMP TYPE P

(PARALLEL RAMP)

DO NOT USE IN AREAS WHERE PONDING MAY OCCUR

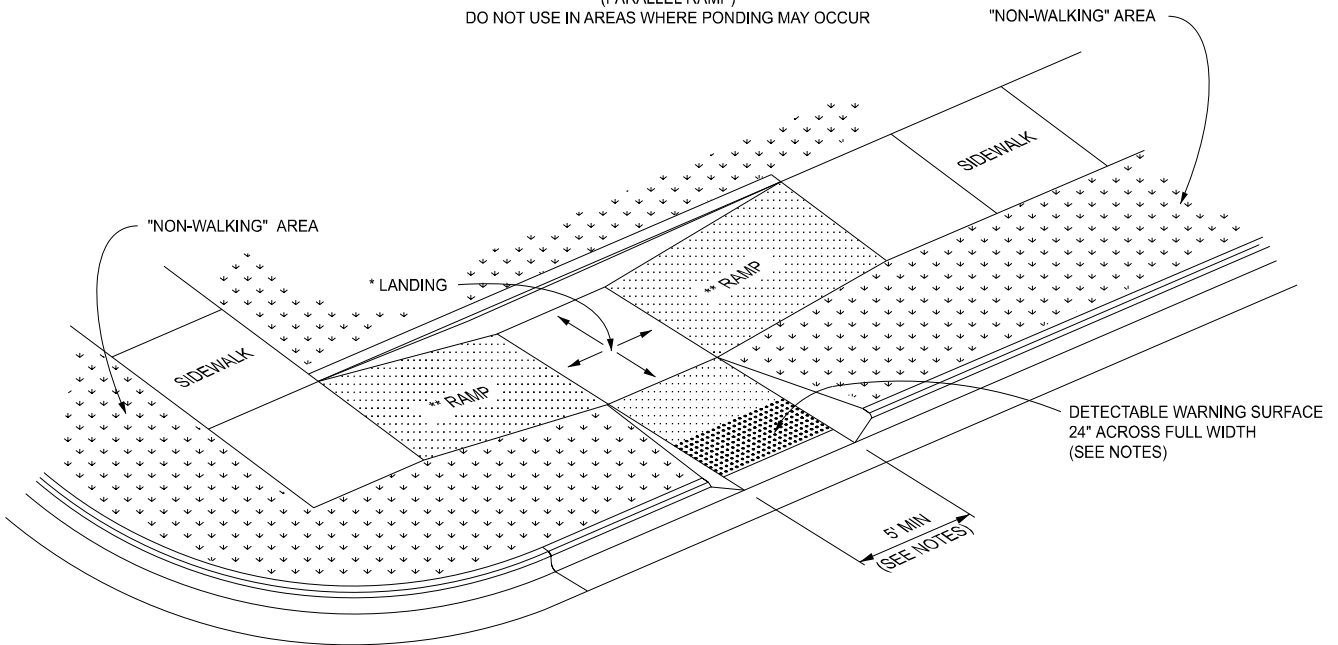

CURB RAMP TYPE C

(COMBINATION RAMP)

USE 24" DETECTABLE WARNING SURFACE ACROSS FULL WIDTH IF MEDIAN WIDTH IS AT LEAST 6'-0". OTHERWISE NO DETECTABLE WARNING IS REQUIRED.

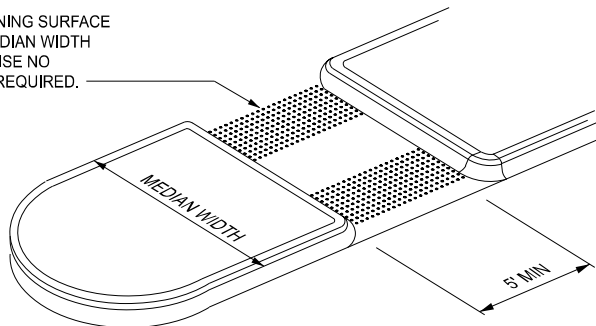

CURB RAMP TYPE M

(MEDIAN ISLAND)

* MAXIMUM LANDING SLOPE IS 2.1% IN EACH DIRECTION OF TRAVEL. LANDING MINIMUM DIMENSIONS 5' x 5'. SEE NOTES.

** MAXIMUM RAMP CROSS SLOPE IS 2.1%, RUNNING SLOPE 5% - 7% (8.3% MAXIMUM). SEE NOTES.

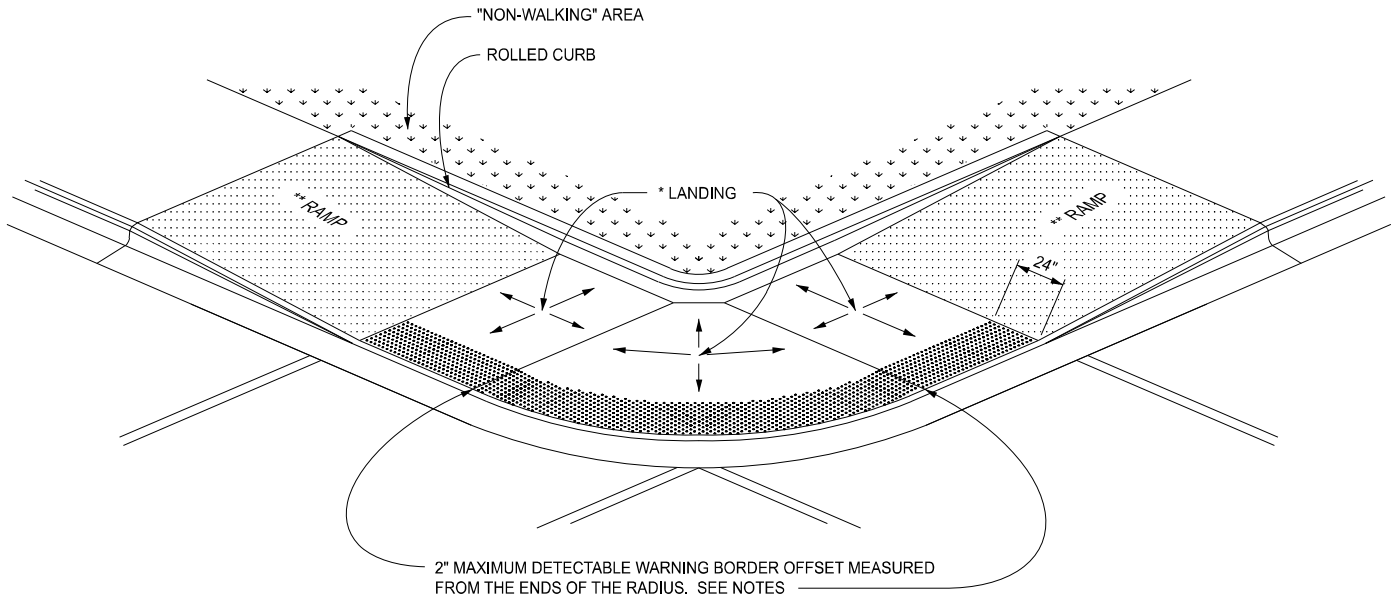

(RADIAL DETECTABLE WARNING SHOWN)

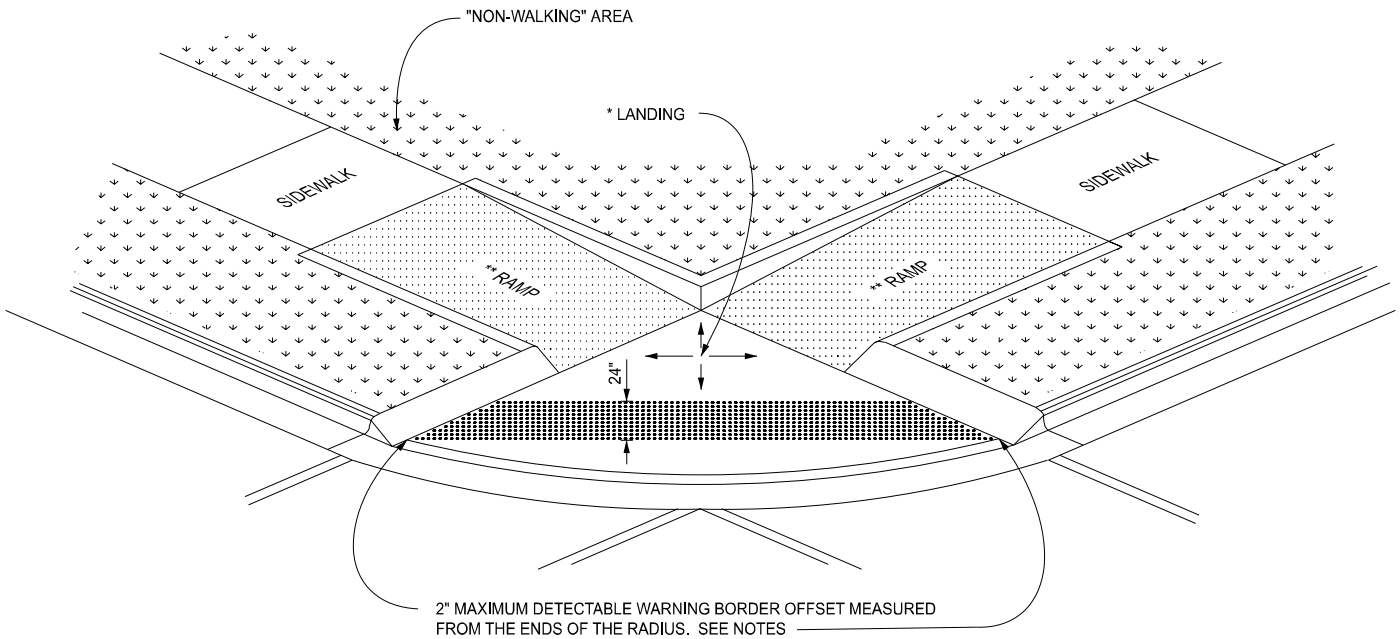

(TANGENT DETECTABLE WARNING SHOWN)

CURB RAMP TYPE D
(DEPRESSED CORNER)

USE ONLY WHEN INDEPENDENT DIRECTIONAL RAMPS CAN NOT BE CONSTRUCTED FOR EACH CROSSING DIRECTION

 DEPARTMENT DIRECTOR BRADLEY C. WIEFERICH, PE	STANDARD PLAN FOR CURB RAMP AND DETECTABLE WARNING DETAILS			R-28-K SHEET 4 OF 7
	12/18/2024 FHWA APPROVAL	06/21/2024 PLAN DATE		

* LOCATE THE DETECTABLE WARNING SURFACE SO THAT THE EDGE NEAREST THE RAIL CROSSING IS 6' MINIMUM AND 15' MAXIMUM FROM THE CENTERLINE OF THE NEAREST RAIL. DO NOT PLACE DETECTABLE WARNING ON RAILROAD CROSSING MATERIAL.

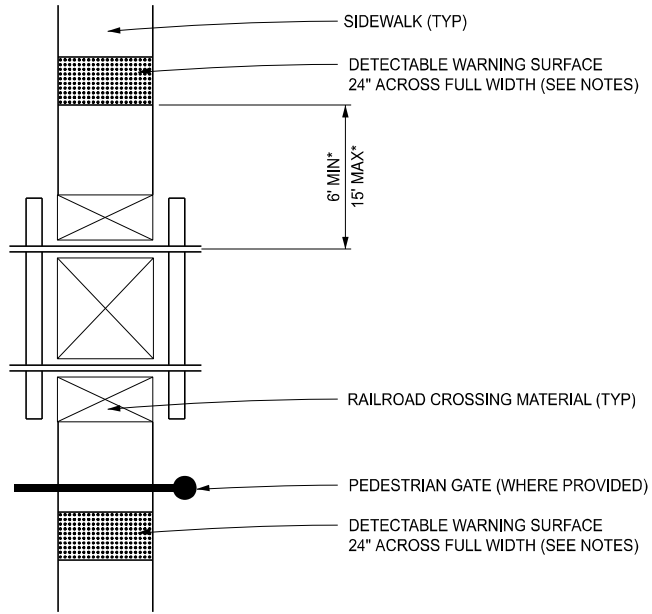

DETECTABLE WARNING AT RAILROAD CROSSING

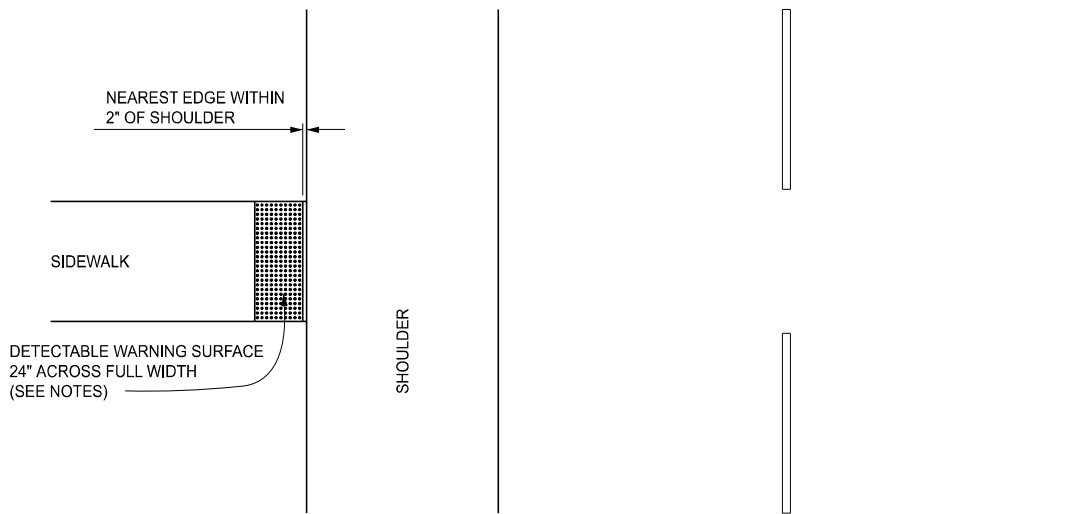

DETECTABLE WARNING AT FLUSH SHOULDER OR ROADWAY

 DEPARTMENT DIRECTOR BRADLEY C. WIEFERICH, PE	STANDARD PLAN FOR CURB RAMP AND DETECTABLE WARNING DETAILS		R-28-K	SHEET 5 OF 7
	12/18/2024 FHWA APPROVAL	06/21/2024 PLAN DATE		

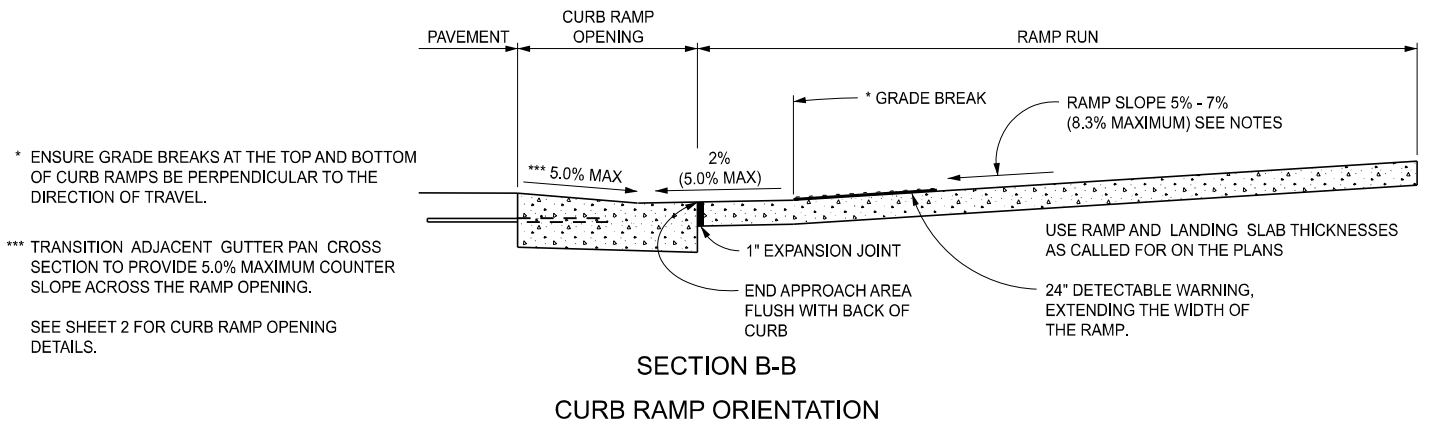
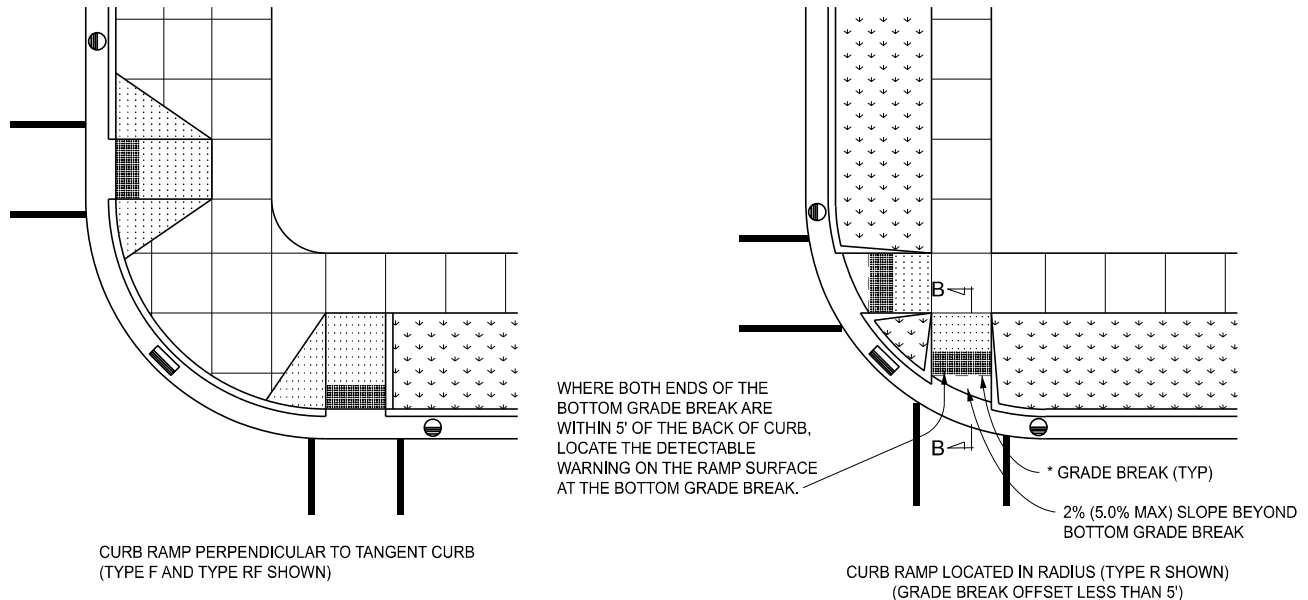
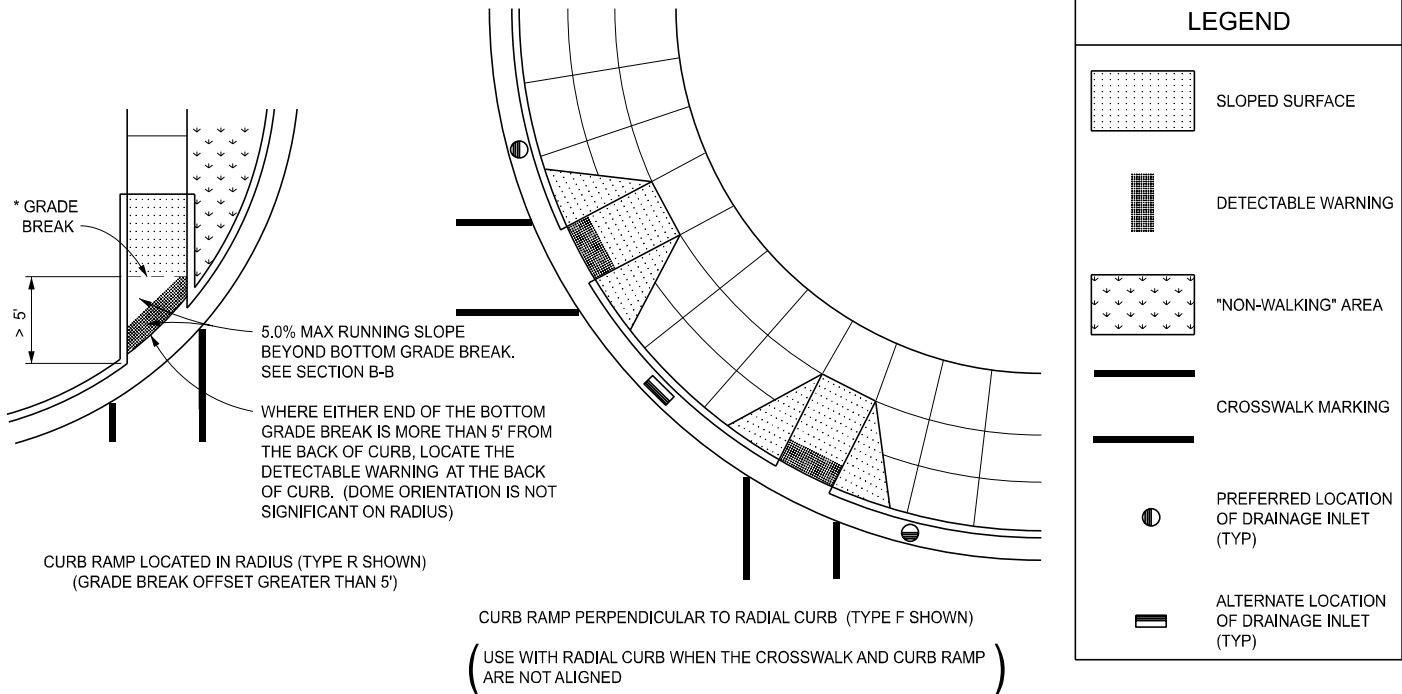

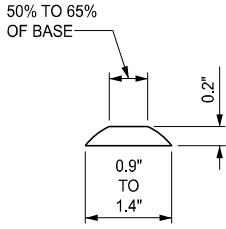

DOME SECTION

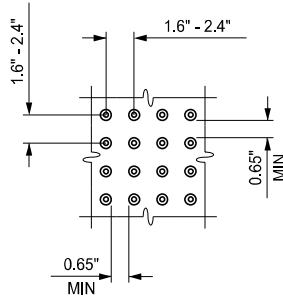

DOME SPACING

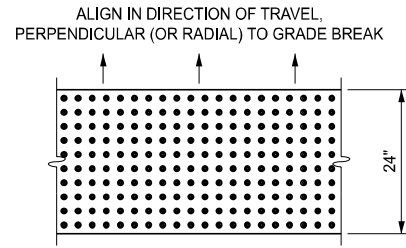

DOME ALIGNMENT

DETECTABLE WARNING DETAILS

NOTES:

APPLY DETAILS SPECIFIED ON THIS PLAN TO ALL CONSTRUCTION, RECONSTRUCTION, OR ALTERATION OF STREETS, CURBS, OR SIDEWALKS IN THE PUBLIC RIGHT OF WAY.

LOCATE CURB RAMPS AS SPECIFIED ON THE PLANS OR AS DIRECTED BY THE ENGINEER.

PROVIDE RAMPS AT ALL CORNERS OF AN INTERSECTION WHERE THERE IS EXISTING OR PROPOSED SIDEWALK AND CURB. PROVIDE RAMPS AT MARKED AND/OR SIGNALIZED MID-BLOCK CROSSINGS.

PROVIDE SURFACE TEXTURE TO THE RAMP BY COARSE BROOMING, TRANSVERSE TO THE RUNNING SLOPE.

RAMP THE SIDEWALK WHERE THE DRIVEWAY CURB IS EXTENDED ACROSS THE WALK.

ENSURE A UNIFORM GRADE ON THE RAMP. SLOPE THE RAMP IN ONLY ONE DIRECTION, PARALLEL TO THE DIRECTION OF TRAVEL, WHERE CONDITIONS PERMIT.

INCREASE RAMP WIDTH, IF NECESSARY, TO ACCOMMODATE SIDEWALK SNOW REMOVAL EQUIPMENT NORMALLY USED BY THE MUNICIPALITY.

REDUCE RAMP WIDTH TO NOT LESS THAN 4' AND LANDINGS TO NOT LESS THAN 4' x 4' WHEN 5' MINIMUM WIDTHS ARE NOT FEASIBLE.

CURB RAMPS WITH A RUNNING SLOPE \leq 5% DO NOT REQUIRE A TOP LANDING. HOWEVER, FOR ANY CONTINUOUS SIDEWALK OR PEDESTRIAN ROUTE CROSSING THROUGH OR INTERSECTING THE CURB RAMP, INDEPENDENTLY MAINTAIN A CROSS SLOPE NOT GREATER THAN 2.1% PERPENDICULAR TO ITS OWN DIRECTION(S) OF TRAVEL.

ENSURE DETECTABLE WARNING SURFACE COVERS A MINIMUM OF 24" IN THE DIRECTION OF RAMP/PATH TRAVEL AND THE FULL WIDTH OF THE RAMP/PATH OPENING, EXCLUDING CURBED OR FLARED CURB TRANSITION AREAS. IF A BORDER IS DESIRED, OFFSET THE BORDER 2" MAXIMUM ALONG THE EDGES OF THE DETECTABLE WARNING. FOR RADIAL CURB, MEASURE THE OFFSET FROM THE ENDS OF THE RADIUS.

DO NOT EXCEED A RAMP CROSS SLOPE OF 2.1% FOR NEW ROADWAY CONSTRUCTION. FOR ALTERATIONS TO EXISTING ROADWAYS, TRANSITION THE CROSS SLOPE TO MEET AN EXISTING ROADWAY GRADE. APPLY THE CROSS SLOPE TRANSITION UNIFORMLY OVER THE FULL LENGTH OF THE RAMP.

THE MAXIMUM RUNNING SLOPE OF 8.3% IS RELATIVE TO A FLAT (0%) REFERENCE. HOWEVER, NO RAMP OR SERIES OF RAMPS IS REQUIRED TO EXCEED 15 FEET IN LENGTH, NOT INCLUDING LANDINGS OR TRANSITIONS.

DO NOT PLACE DRAINAGE STRUCTURES IN LINE WITH RAMPS. GIVE PRECEDENCE TO THE LOCATION OF THE RAMP, OVER THE LOCATION OF THE DRAINAGE STRUCTURE. WHERE EXISTING DRAINAGE STRUCTURES ARE LOCATED IN THE RAMP PATH OF TRAVEL, USE A MANUFACTURER'S ADA COMPLIANT GRATE. LIMIT OPENINGS TO 1/2" OR LESS. PLACE ELONGATED OPENINGS SO THAT THE LONG DIMENSION IS PERPENDICULAR TO THE DOMINANT DIRECTION OF TRAVEL.

ENSURE THE TOP OF THE JOINT FILLER (FOR ALL RAMP TYPES) IS FLUSH WITH THE ADJACENT CONCRETE.

LOCATE CROSSWALK AND STOP LINE MARKINGS TO STOP TRAFFIC SHORT OF RAMP CROSSINGS. SEE THE "MICHIGAN MANUAL ON UNIFORM TRAFFIC CONTROL DEVICES" FOR SPECIFIC DETAILS FOR MARKING APPLICATIONS.

PROVIDE FLARED SIDES WITH A MAXIMUM SLOPE OF 10%, MEASURED ALONG THE ROADSIDE CURB LINE, WHERE AN UNOBSTRUCTED CIRCULATION PATH LATERALLY CROSSES THE CURB RAMP. FLARED SIDES ARE NOT REQUIRED WHERE THE RAMP IS BORDERED BY LANDSCAPING, UNPAVED SURFACE OR PERMANENT FIXED OBJECTS. WHERE NOT REQUIRED, CONSIDER FLARED SIDES IN ORDER TO AVOID SHARP CURB RETURNS AT RAMP OPENINGS.

INSTALL DETECTABLE WARNING PLATES USING FABRICATED OR FIELD CUT UNITS CAST AND/OR ANCHORED IN THE PAVEMENT TO RESIST SHIFTING OR HEAVING.



DEPARTMENT DIRECTOR
BRADLEY C. WIEFERICH, PE

STANDARD PLAN FOR
CURB RAMP AND
DETECTABLE WARNING DETAILS

12/18/2024
FHWA APPROVAL

06/21/2024
PLAN DATE

R-28-K

SHEET
7 OF 7

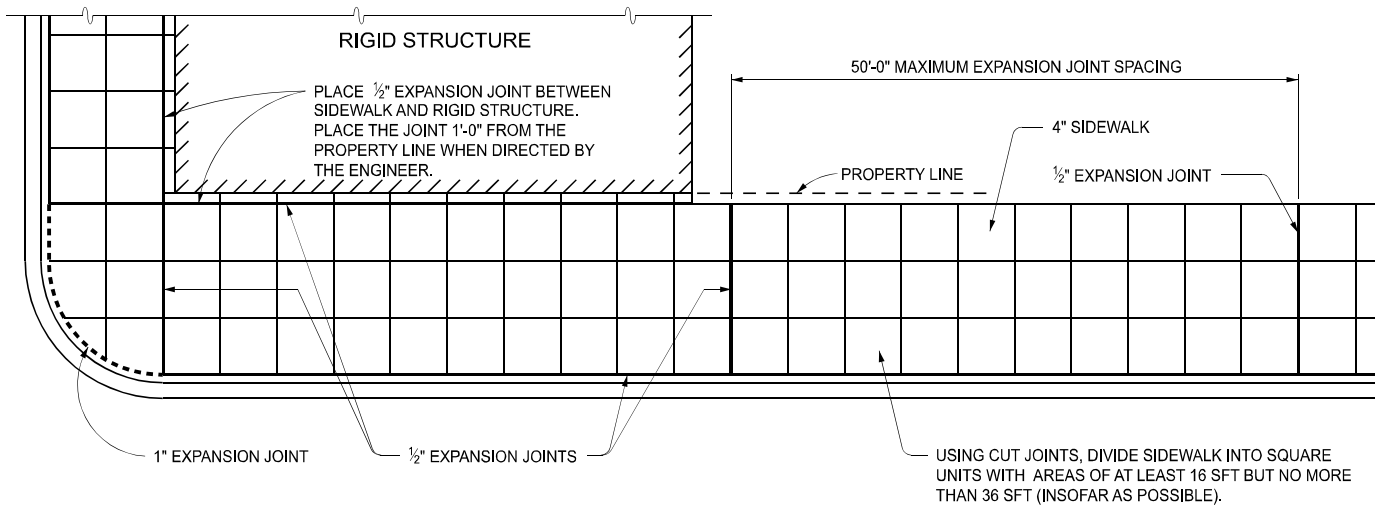
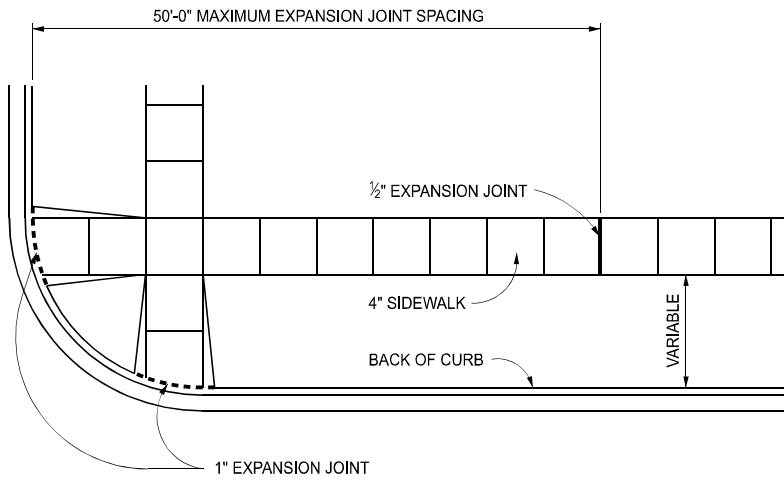

LOCATION OF JOINTS IN CONCRETE SIDEWALK

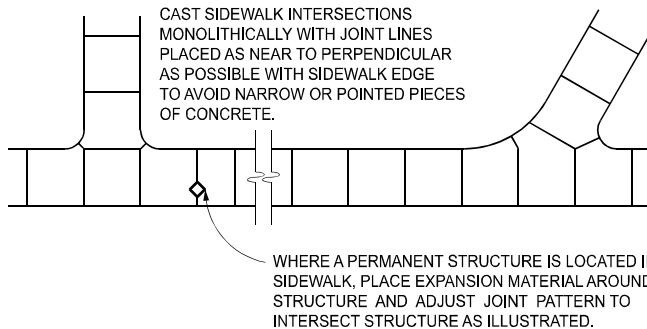

TYPICAL SIDEWALK JOINT LAYOUTS

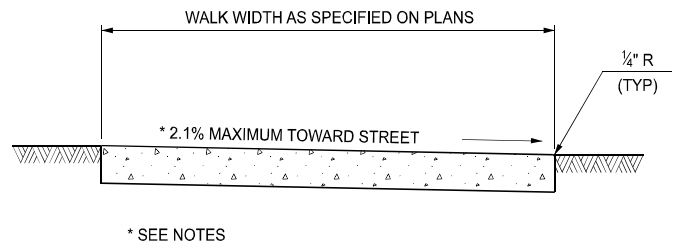

4" CONCRETE SIDEWALK

APPROVED BY: E-SIGNED by JASON GUTTING on 2024-09-24 12:55:49 EDT
DIRECTOR, BUREAU OF FIELD SERVICES

APPROVED BY: E-SIGNED by Demetrius Parker on 2024-09-24 09:51:28 EDT
DIRECTOR, BUREAU OF DEVELOPMENT



DEPARTMENT DIRECTOR
BRADLEY C. WIEFERICH, PE

STANDARD PLAN FOR
DRIVEWAY OPENINGS & APPROACHES,
AND CONCRETE SIDEWALK

12/18/2024
FHWA APPROVAL

06/12/2024
PLAN DATE

R-29-J

SHEET
1 OF 4

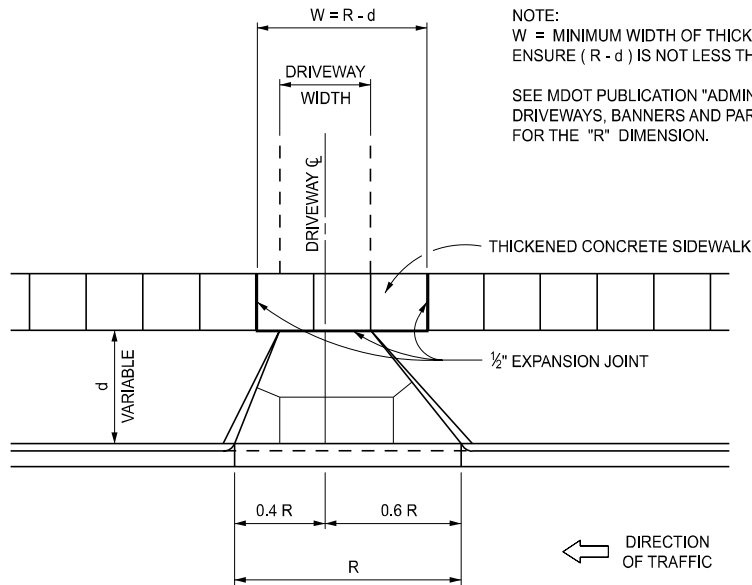

NOTE:
 $W =$ MINIMUM WIDTH OF THICKENED CONCRETE SIDEWALK.
 ENSURE $(R - d)$ IS NOT LESS THAN DRIVEWAY WIDTH.

SEE MDOT PUBLICATION "ADMINISTRATIVE RULES REGULATING DRIVEWAYS, BANNERS AND PARADES ON OR OVER HIGHWAYS" FOR THE "R" DIMENSION.

CONCRETE DRIVEWAY OPENING LAYOUT

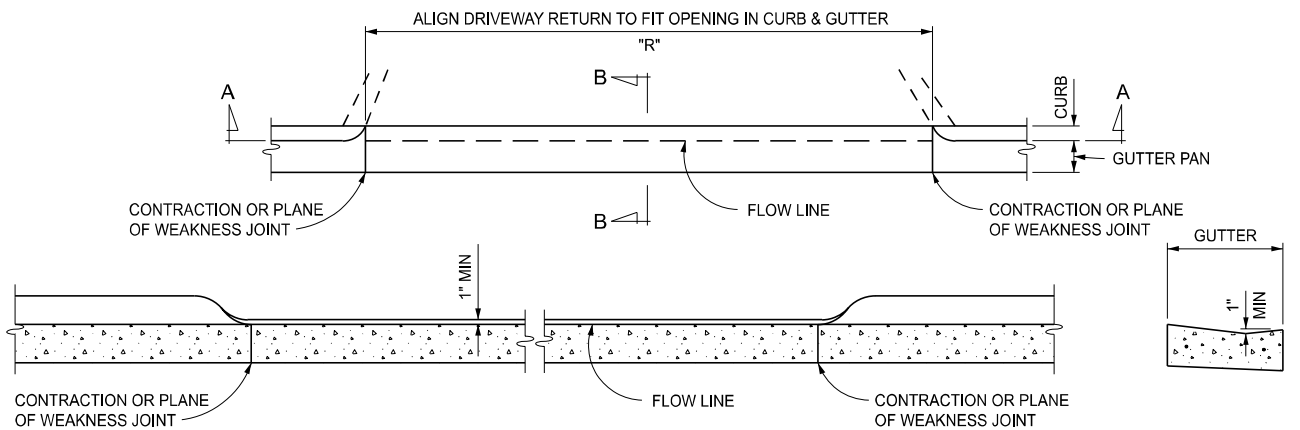

SECTION A - A
 SECTION B - B
 CONCRETE DRIVEWAY OPENING, DETAIL L

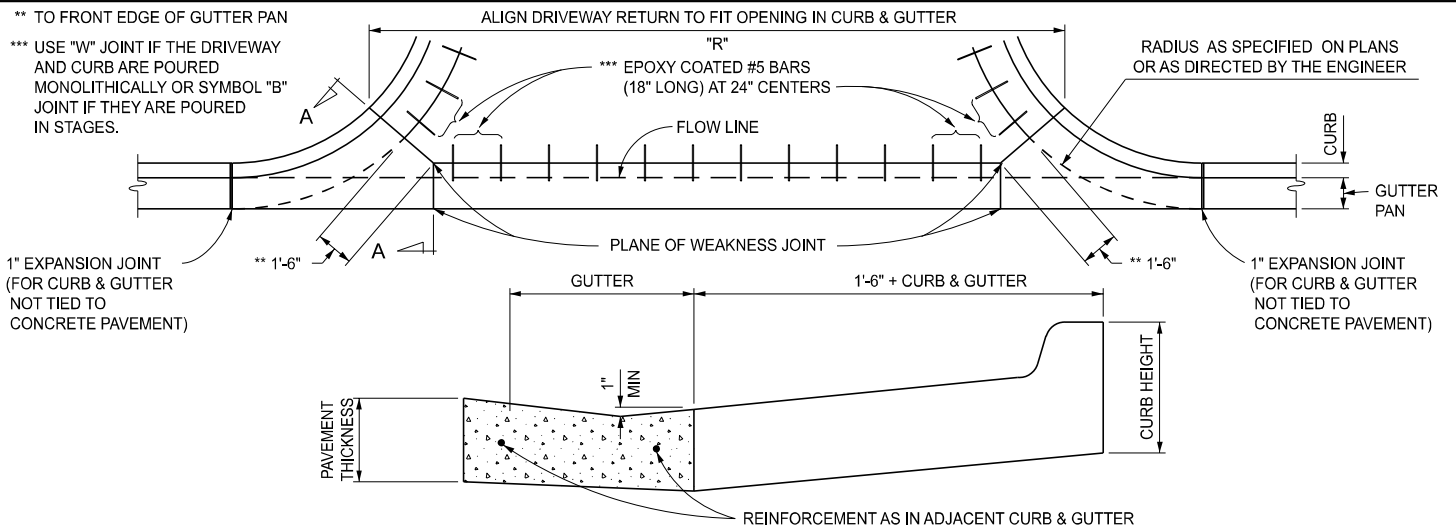

SECTION A - A
 CONCRETE DRIVEWAY OPENING, DETAIL M

NOTE:
 ENSURE LONGITUDINAL LANE TIES ARE CONTINUOUS THROUGH THE DRIVEWAY OPENING IN ROADWAYS WITH CONCRETE PAVEMENTS AND ADJUST THE SPACING OF THE #5 BARS IN CONCRETE DRIVEWAYS TO AVOID CONFLICT WITH THE LONGITUDINAL LANE TIES.



STANDARD PLAN FOR DRIVEWAY OPENINGS & APPROACHES, AND CONCRETE SIDEWALK			
12/18/2024 FHWA APPROVAL	06/12/2024 PLAN DATE	R-29-J	SHEET 2 OF 4

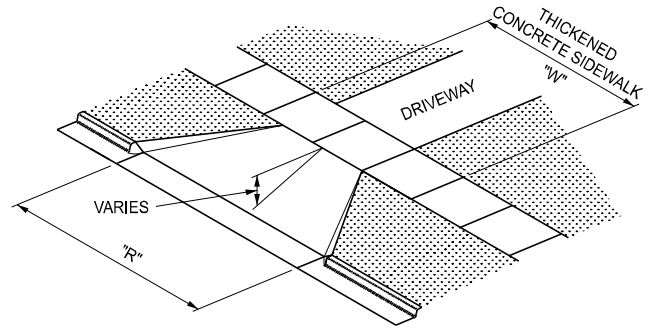
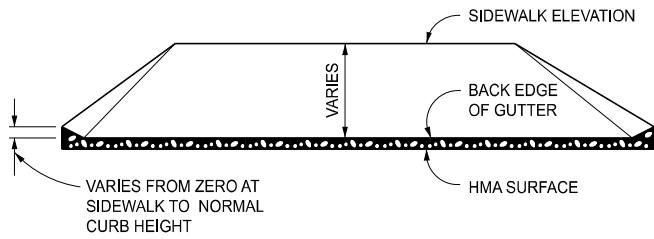

HMA DRIVEWAY APPROACH
(TO BE USED WITH DETAIL L)

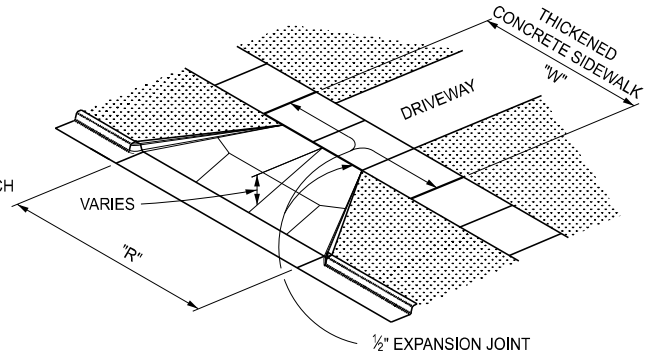
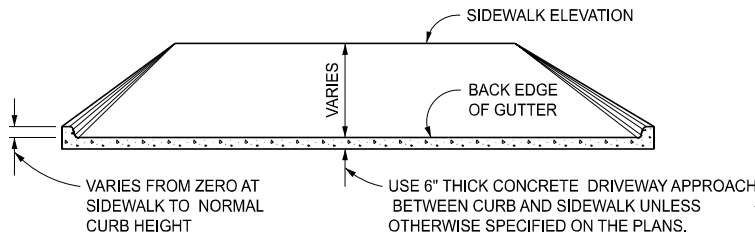

NOTES:
INCLUDE MONOLITHIC CURB IN THE CONCRETE DRIVEWAY APPROACH QUANTITY.
SEE CHART ON THIS SHEET WHEN REINFORCEMENT IS REQUIRED (SPECIFIED ON THE PLANS).

CONCRETE DRIVEWAY APPROACH
(TO BE USED WITH DETAIL L OR M)

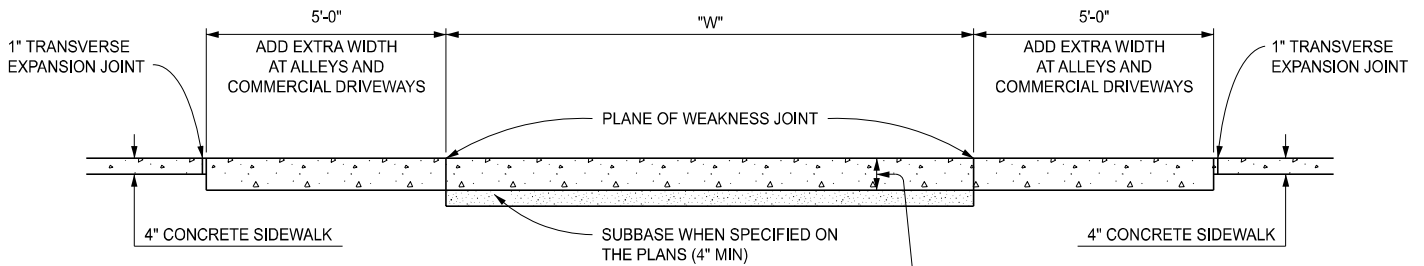

WHEN CONCRETE DRIVEWAY APPROACH IS SPECIFIED, MATCH THICKENED CONCRETE SIDEWALK THICKNESS TO THICKNESS OF CONCRETE DRIVEWAY APPROACH. WHEN HMA DRIVEWAY APPROACH IS SPECIFIED, USE 6\"

THICKENED CONCRETE SIDEWALK

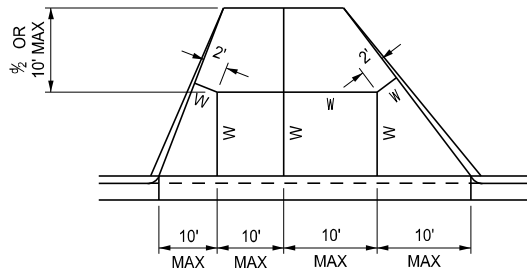

ADJUST DRIVEWAY JOINTS AS NEEDED TO ALIGN WITH ANY COINCIDING TRANSVERSE PAVEMENT JOINTS.

USE JOINT LAYOUT AS INDICATED OR AS DIRECTED BY THE ENGINEER.

INTERMEDIATE DRIVEWAY JOINT DETAILS

REINFORCEMENT FOR CONCRETE DRIVEWAYS		
CONCRETE DRIVEWAY THICKNESS	WIRE SIZE (6" x 6" MESH)	AVERAGE WEIGHT (LBS/100 SFT)
LESS THAN 8"	W1.4	21
	W2.9	42
8" OR GREATER	USE WIRE FABRIC REINFORCEMENT SPECIFIED ON STANDARD PLAN R-37-SERIES	



DEPARTMENT DIRECTOR
BRADLEY C. WIEFERICH, PE

STANDARD PLAN FOR
**DRIVEWAY OPENINGS & APPROACHES,
AND CONCRETE SIDEWALK**

12/18/2024
FHWA APPROVAL

06/12/2024
PLAN DATE

R-29-J

SHEET
3 OF 4

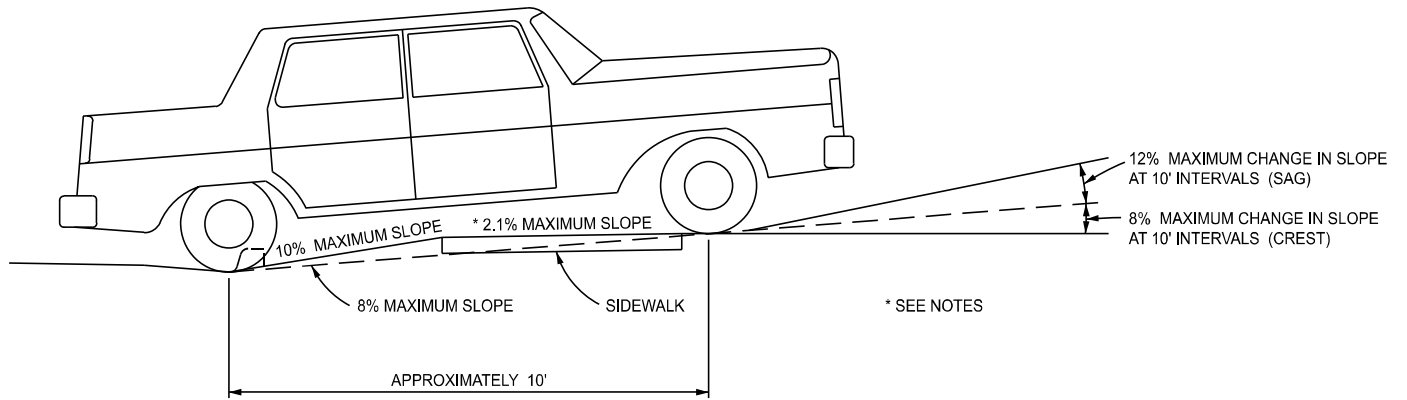

LOW VOLUME COMMERCIAL OR RESIDENTIAL DRIVEWAY SLOPES

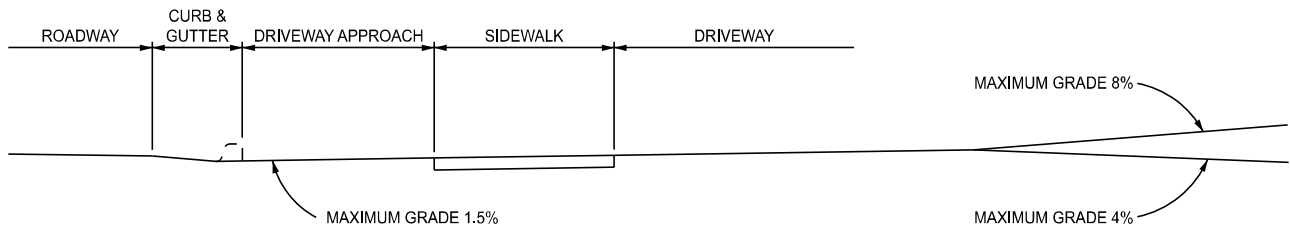

COMMERCIAL DRIVEWAY PROFILE FOR MAJOR TRAFFIC GENERATORS

NOTES:

SEE MDOT PUBLICATION "ADMINISTRATIVE RULES REGULATING DRIVEWAYS, BANNERS, AND PARADES ON OR OVER HIGHWAYS" AND GEOMETRIC DESIGN GUIDE G-680-SERIES, "COMMERCIAL DRIVEWAYS" FOR DRIVEWAY DESIGN.

SEE STANDARD PLAN R-30-SERIES FOR CURB AND GUTTER DETAILS.

LIMIT TRANSVERSE SIDEWALK SLOPES TO 2.1% MAXIMUM. PROVIDE LONGITUDINAL DRAINAGE IF THE TRANSVERSE SLOPE IS REQUIRED TO BE LESS THAN 1.5%.

CONSIDER THE TYPES OF VEHICLES USING THE DRIVE WHEN SETTING GRADES FOR COMMERCIAL DRIVES.



DEPARTMENT DIRECTOR
BRADLEY C. WIEFERICH, PE

STANDARD PLAN FOR
DRIVEWAY OPENINGS & APPROACHES,
AND CONCRETE SIDEWALK

12/18/2024
FHWA APPROVAL

06/12/2024
PLAN DATE

R-29-J

SHEET
4 OF 4

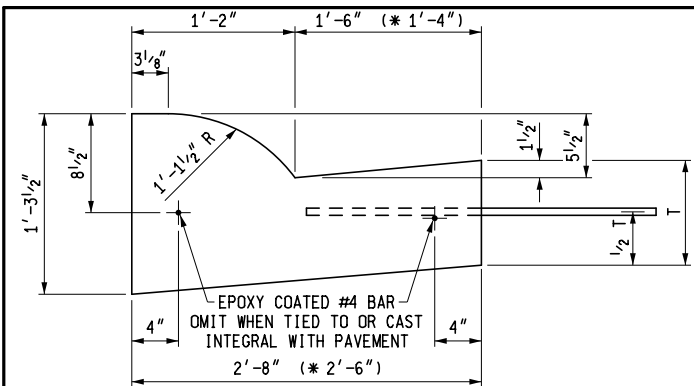

(* GUTTER PAN WIDTH MAY BE REDUCED WHEN APPROVED BY THE ENGINEER)

DETAIL	DIMENSION	LANE TIES	CONCRETE CYD / LFT	CONCRETE CYD / LFT
	T			
B1	9"	AS SHOWN	0.0900	(* 0.0855)
B2	9"	OMITTED	0.0900	(* 0.0855)
B3	10"	AS SHOWN	0.0941	(* 0.0894)

B

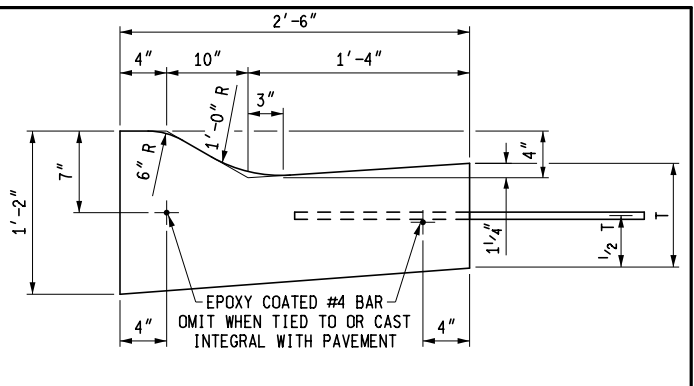

DETAIL	DIMENSION	LANE TIES	CONCRETE CYD / LFT
	T		
D1	9"	AS SHOWN	0.0788
D2	9"	OMITTED	0.0788
D3	10"	AS SHOWN	0.0826

D

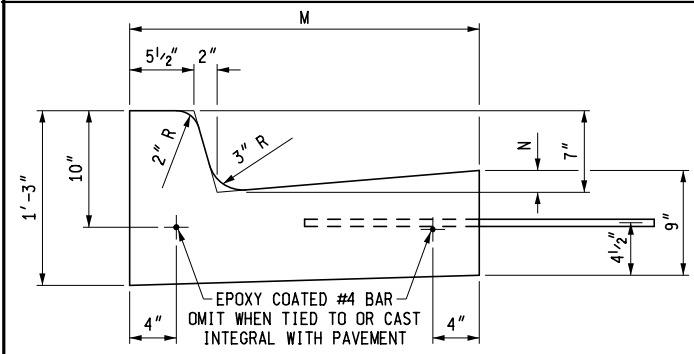

DETAIL	DIMENSION		LANE TIES	CONCRETE CYD / LFT
	M	N		
C1	1'-6"	7/8"	AS SHOWN	0.0506
C2	1'-6"	7/8"	OMITTED	0.0506
C3	2'-0"	1 3/8"	AS SHOWN	0.0632
C4	2'-0"	1 3/8"	OMITTED	0.0632
C5	2'-6"	1 7/8"	AS SHOWN	0.0757
C6	2'-6"	1 7/8"	OMITTED	0.0757

C

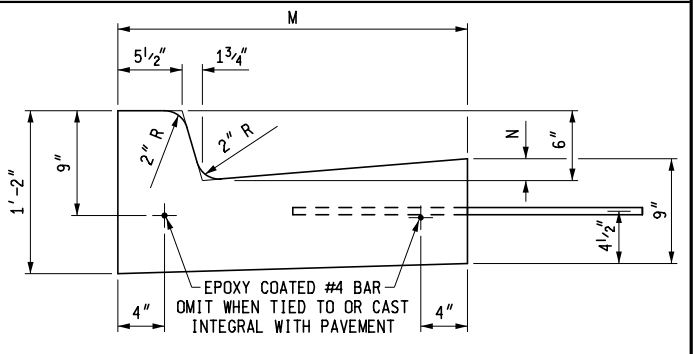

DETAIL	DIMENSION		LANE TIES	CONCRETE CYD / LFT
	M	N		
F1	1'-6"	7/8"	AS SHOWN	0.0484
F2	1'-6"	7/8"	OMITTED	0.0484
F3	2'-0"	1 3/8"	AS SHOWN	0.0610
F4	2'-0"	1 3/8"	OMITTED	0.0610
F5	2'-6"	1 7/8"	AS SHOWN	0.0737
F6	2'-6"	1 7/8"	OMITTED	0.0737

F

* WHEN OTHER THAN 7" (4" MIN. TO 9" MAX.) FACE EXPOSURE IS SPECIFIED ON PLANS, VARY TOTAL CURB HEIGHT AND BATTER ACCORDINGLY

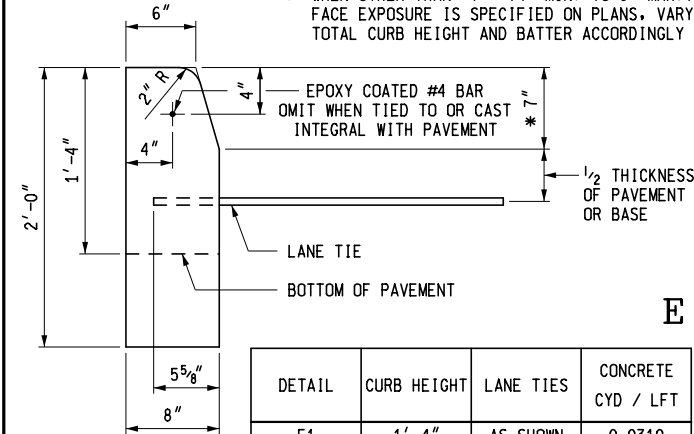

DETAIL	CURB HEIGHT	LANE TIES	CONCRETE CYD / LFT
E1	1'-4"	AS SHOWN	0.0310
E2	1'-4"	OMITTED	0.0310
E4	2'-0"	OMITTED	0.0477

E

MDOT
Michigan Department of Transportation

PREPARED BY
DESIGN DIVISION

DRAWN BY: B.L.T.

CHECKED BY: W.K.P.

DEPARTMENT DIRECTOR
Kirk T. Stuedle

APPROVED BY: *Randy V. Puffel*
DIRECTOR, BUREAU OF FIELD SERVICES

APPROVED BY: *Mark A. Van Pelt*
DIRECTOR, BUREAU OF HIGHWAY DEVELOPMENT

MICHIGAN DEPARTMENT OF TRANSPORTATION
BUREAU OF HIGHWAY DEVELOPMENT STANDARD PLAN FOR

**CONCRETE CURB AND
CONCRETE CURB & GUTTER**

9-30-2014 F.H.W.A. APPROVAL	2-6-2014 PLAN DATE	R-30-G	SHEET 1 OF 2
--------------------------------	-----------------------	---------------	-----------------

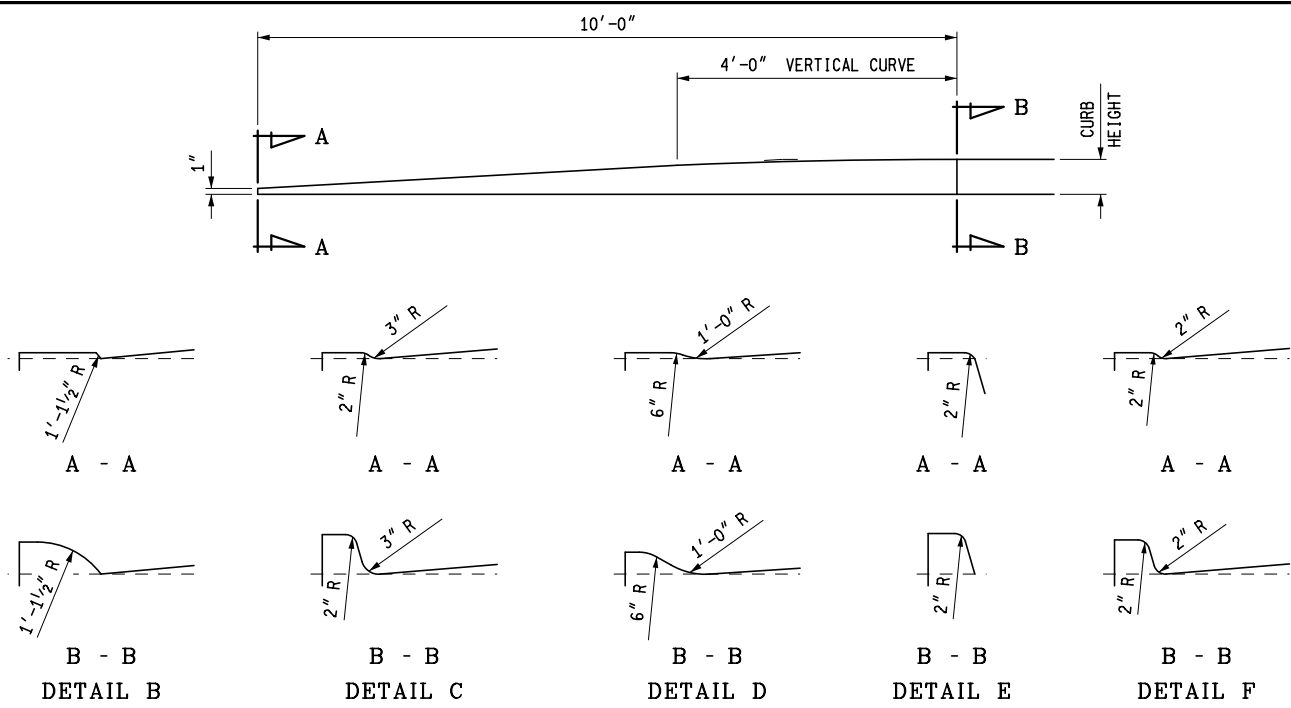

CONCRETE CURB, CURB AND GUTTER ENDINGS

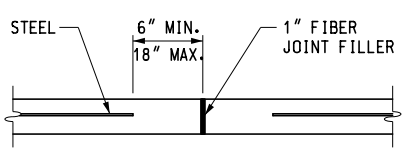

1" FIBER JOINT FILLER

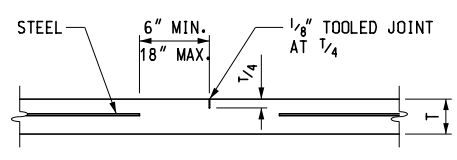

CONTRACTION JOINT

NOTES:

- CURB AND GUTTER RADII SHALL BE DIMENSIONED TO THE FRONT EDGE OF THE GUTTER PAN OR EDGE OF PAVEMENT.
- CONCRETE CURB AND GUTTER ENDINGS WILL BE PAID FOR IN LINEAR FEET OF THE ADJACENT CURB DETAIL.
- JOINTS SHALL BE PLACED AT RIGHT ANGLES TO THE EDGE OF CONCRETE CURB AND GUTTER.
- JOINTS DETAILED ON THE PLANS SHALL SUPERSEDE THOSE SPECIFIED ON THIS STANDARD PLAN.
- BOTTOM SLOPE OF CURB AND GUTTER STRUCTURE MAY BE THE SAME SLOPE AS BOTTOM OF PAVEMENT. BACK OF CURB AND VERTICAL EDGE OF GUTTER PAN MAY HAVE A MAXIMUM 1/2" BATTER TO FACILITATE FORMING.
- WHEN CURB AND GUTTER IS CAST INTEGRALLY, SEE CURRENT STANDARD PLAN R-31-SERIES.
- ALL JOINTS FOR CURB OR CURB AND GUTTER ARE INCLUDED IN THE PAY ITEM FOR THE CURB OR CURB AND GUTTER.

JOINTS IN CURB OR CURB AND GUTTER NOT TIED TO CONCRETE PAVEMENT; ADJACENT TO CONCRETE BASE COURSE; OR ADJACENT TO HMA PAVEMENT:

- A. PLACE 1" FIBER JOINT FILLER AT 400' MAXIMUM INTERVALS.
- B. PLACE 1" FIBER JOINT FILLER AT SPRING POINTS OF INTERSECTING STREETS.
- C. PLACE 1/2" ISOLATION JOINT AT CATCH BASINS PER STANDARD PLAN R-37-SERIES.
- D. PLACE CONTRACTION JOINTS AT 40' MAXIMUM INTERVALS.

JOINTS IN CURB OR CURB AND GUTTER TIED TO JOINTED PAVEMENT

- A. PLACE 1" FIBER JOINT FILLER OPPOSITE ALL TRANSVERSE EXPANSION JOINTS IN PAVEMENT.
- B. PLACE 1/2" ISOLATION JOINT AT CATCH BASINS PER STANDARD PLAN R-37-SERIES.
- C. PLACE CONTRACTION JOINTS OPPOSITE ALL TRANSVERSE CONTRACTION JOINTS IN PAVEMENT.
- D. A SYMBOL (B) JOINT SHALL BE PLACED BETWEEN CURB OR CURB AND GUTTER AND ADJACENT CONCRETE PAVEMENT AS SPECIFIED ON STANDARD PLAN R-41-SERIES.





MICHIGAN DEPARTMENT OF TRANSPORTATION
BUREAU OF HIGHWAY DEVELOPMENT STANDARD PLAN FOR

**CONCRETE CURB AND
CONCRETE CURB & GUTTER**

9-30-2014 F.H.W.A. APPROVAL	2-6-2014 PLAN DATE	R-30-G	SHEET 2 OF 2
--------------------------------	-----------------------	--------	-----------------

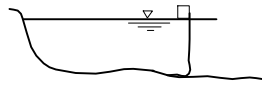
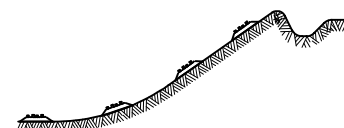
● APPLICABLE SOIL EROSION AND SEDIMENTATION CONTROL MEASURES
 (COMPREHENSIVE DETAILS ARE LOCATED IN SECTION 6 OF
 THE SOIL EROSION & SEDIMENTATION CONTROL MANUAL)

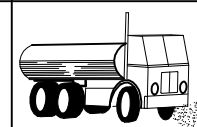
- A = SLOPES
- B = STREAMS AND WATERWAYS
- C = SURFACE DRAINAGEWAYS
- D = ENCLOSED DRAINAGE (INLET & OUTFALL CONTROL)
- E = LARGE FLAT SURFACE AREAS
- F = BORROW AND STOCKPILE AREAS
- G = DNRE PERMIT MAY BE REQUIRED

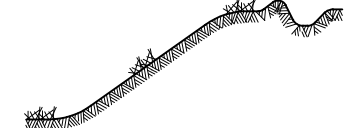
KEY	DETAIL	CHARACTERISTICS	A	B	C	D	E	F	G
1	 TURBIDITY CURTAIN	A Turbidity Curtain is used when slack water area is necessary to isolate construction activities from the watercourse. The still water area contains the sediments within the construction limits.		●					
2	 GRUBBING OMITTED	Retains existing root mat which assists in stabilizing slopes. Assists in the revegetation process by providing sprout growth. Reduces sheet flow velocities preventing rilling and gulying. Discourages off-road vehicle use.		●				●	
3	 PERMANENT/TEMPORARY SEEDING	Inexpensive but effective erosion control measure to stabilize flat areas and mild slopes. Permits runoff to infiltrate soil, reducing runoff volumes. Proper preparation of the seed bed, fertilizing, mulching and watering is critical to its success.		●		●		●	●
4	 DUST CONTROL	Dust control can be accomplished by watering, and/or applying calcium chloride. The disturbed areas should be kept to a minimum. PERMANENT/TEMPORARY SEEDING (KEY 3) should be applied as soon as possible.		●				●	●
5	 SODDING	Provides immediate vegetative cover such as at spillways and ditch bottoms. Proper preparation of the topsoil, placement of the sod, and watering is critical to its success.		●				●	●
6	 VEGETATED BUFFER STRIPS	Reduces sheet flow velocities preventing rilling and gulying. Assists in the collection of sediments by filtering runoff. Assists in the establishment of a permanent vegetative cover.		●				●	



PREPARED BY
 DESIGN DIVISION

DRAWN BY: B.L.T.

CHECKED BY: W.K.P.

DEPARTMENT DIRECTOR
 Kirk T. Stuedle

APPROVED BY: John C. Friend
 ENGINEER OF DELIVERY

APPROVED BY: Mark A. Van Pelt
 ENGINEER OF DEVELOPMENT

MICHIGAN DEPARTMENT OF TRANSPORTATION
 BUREAU OF HIGHWAY DEVELOPMENT STANDARD PLAN FOR





SOIL EROSION & SEDIMENTATION
 CONTROL MEASURES

9-10-2010
 F.H.W.A. APPROVAL

6-3-2010
 PLAN DATE

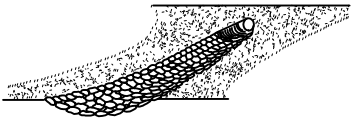
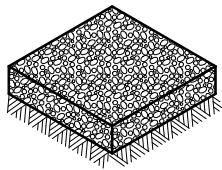
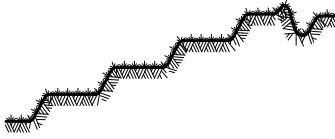
R-96-E

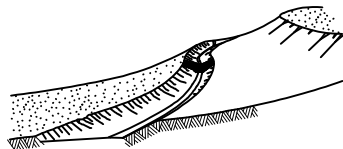
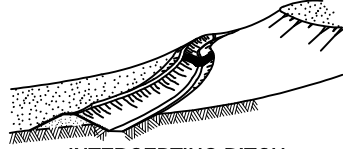
SHEET
 1 OF 6

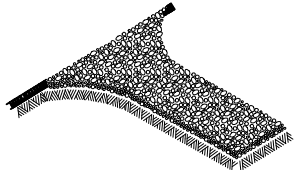
KEY	DETAIL	CHARACTERISTICS	A	B	C	D	E	F	G
7	 <p>RIPRAP</p>	Used where vegetation cannot be established. Very effective in protecting against high velocity flows. Should be placed over a geotextile liner.	•	•	•	•			•
8	 <p>AGGREGATE COVER</p>	Can be used in any area where a stable condition is needed for construction operations, equipment storage or in heavy traffic areas. Reduces potential soil erosion and fugitive dust by stabilizing raw areas.	•				•	•	
9	 <p>BENCHES</p>	Reduces sheet flow velocities preventing rilling and gulying. Assists in the collection and filtering of sediments. Provides access for stabilizing slopes.	•					•	
10	 <p>DIVERSION DIKE</p>	Assists in the diversion of runoff to a stable outlet or sediment control device. Reduces sheet flow velocities preventing rilling and gulying. Collects and diverts runoff to properly stabilized drainage ways. Works well with INTERCEPTING DITCH (KEY 11)	•				•	•	
11	 <p>INTERCEPTING DITCH</p>	Assists in the diversion of runoff to a stable outlet or sediment control device. Reduces sheet flow velocities preventing rilling and gulying. Works well with DIVERSION DIKE (KEY 10)	•				•	•	
12	 <p>INTERCEPTING DITCH AND DIVERSION DIKE</p>	Assists in the diversion of runoff to a stable outlet or sediment control device. Reduces sheet flow velocities preventing rilling and gulying.	•				•	•	
13	 <p>GRAVEL FILTER BERM</p>	Useful in filtering flow prior to its reentry into a lake, stream or wetland. Works well with SEDIMENT TRAP (KEY 20) and TEMPORARY BYPASS CHANNEL (KEY 35). Not to be used in lieu of a CHECK DAM (KEY 37) in a ditch.	•		•			•	
14	 <p>GRAVEL ACCESS APPROACH</p>	Provides a stable access to roadways minimizing fugitive dust and tracking of materials onto public streets and highways.						•	•

MICHIGAN DEPARTMENT OF TRANSPORTATION
BUREAU OF HIGHWAY DEVELOPMENT STANDARD PLAN FOR







SOIL EROSION & SEDIMENTATION
CONTROL MEASURES

9-10-2010
F.H.W.A. APPROVAL

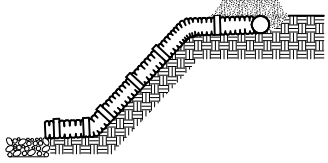
6-3-2010
PLAN DATE

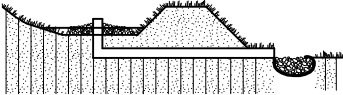
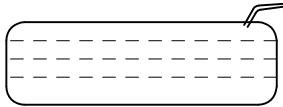
R-96-E

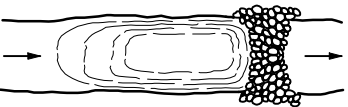
SHEET
2 OF 6

KEY	DETAIL	CHARACTERISTICS	A	B	C	D	E	F	G
15	 SLOPE DRAIN SURFACE	Excellent device for carrying water down slopes without creating an erosive condition. Generally used in conjunction with DIVERSION DIKE (KEY 10), INTERCEPTING DITCH (KEY 11) and INTERCEPTING DITCH AND DIVERSION DIKE (KEY 12) to direct flow to a stable discharge area or SEDIMENT TRAP (KEY 20).		•		•			
16	 TREES, SHRUBS AND PERENNIALS	Trees, shrubs and perennials can provide low maintenance long term erosion protection. These plants may be particularly useful where site aesthetics are important along the roadside slopes.		•				•	
17	 PIPE DROP	Effective way to allow water to drop in elevation very rapidly without causing an erosive condition. Also works as a sediment collector device. May be left in place as a permanent erosion control device.		•		•			
18	 DEWATERING WITH FILTER BAG	It may be necessary to dewater from behind a cofferdam or construction dam to create a dry work site. Discharged water must be pumped to a filter bag. A GRAVEL FILTER BERM (KEY 13) may be placed downslope of the filter bag to provide additional filtration prior to entering any stream or wetland.			•				•
19	 ENERGY DISSIPATORS	A device to prevent the erosive force of water from eroding soils. Used at outlets of culverts, drainage pipes or other conduits to reduce the velocity of the water. Prevents structure scouring and undermining.		•	•	•	•		
20	 SEDIMENT TRAP	Used to intercept concentrated flows and prevent sediments from being transported off site or into a watercourse or wetland. The size of a Sediment Trap is 5 cubic yards or less. Works well when used with CHECK DAM (KEY 37).		•		•	•		
21	 SEDIMENT BASIN	A Sediment Basin is used to trap sediments from an upstream construction site. Requires periodic inspections, repairs, and maintenance. Where practical, sediments should be contained on site. A Sediment Basin should be the last choice of sediment control. The size of a Sediment Basin is greater than 5 cubic yards.			•				•
22	 VEGETATIVE BUFFER AT WATERCOURSE	This practice is used to maintain a vegetative buffer adjacent to a watercourse. When utilized with SILT FENCE (KEY 26) it will, under normal circumstances, prevent sediment from leaving the construction site.		•	•	•		•	•

MICHIGAN DEPARTMENT OF TRANSPORTATION
BUREAU OF HIGHWAY DEVELOPMENT STANDARD PLAN FOR

SOIL EROSION & SEDIMENTATION
CONTROL MEASURES

9-10-2010
F.H.W.A. APPROVAL

6-3-2010
PLAN DATE

R-96-E

SHEET
3 OF 6

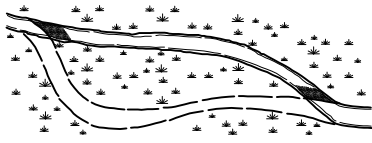
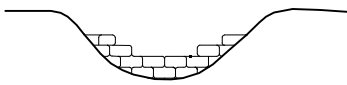
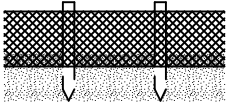
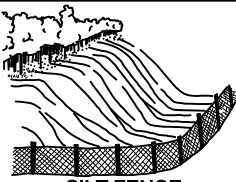
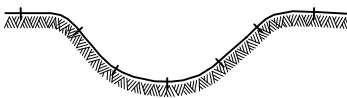
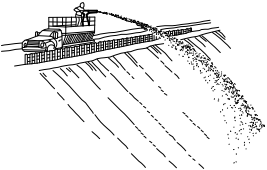
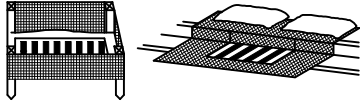
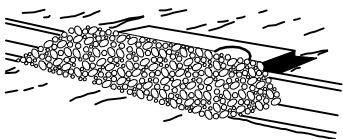
KEY	DETAIL	CHARACTERISTICS	A	B	C	D	E	F	G
23	 <p>STREAM RELOCATION</p>	<p>A detail depicting the proper procedures for stream relocation. Maintains same width, depth, and flow velocity as the natural stream. Revegetate banks with PERMANENT/TEMPORARY SEEDING (KEY 3), MULCHING AND MULCH ANCHORING (KEY 28), MULCH BLANKETS AND HIGH VELOCITY MULCH BLANKETS (KEY 33) and woody plants to shade the stream.</p>		•					•
24	 <p>SAND AND STONE BAGS</p>	<p>Sand and stone bags are a useful tool in the prevention of erosion. Can be used to divert water around a construction site by creating a DIVERSION DIKE (KEY 10). Works well for creating a CONSTRUCTION DAM (KEY 36) and temporary culvert end fill.</p>	•	•	•	•	•	•	•
25	 <p>SAND FENCE AND DUNE STABILIZATION</p>	<p>A Sand Fence traps blowing sand by reducing wind velocities. Can be used to prevent sand from blowing onto roads. Must be maintained until sand source is stabilized.</p>	•				•	•	
26	 <p>SILT FENCE</p>	<p>A permeable barrier erected below disturbed areas to capture sediments from sheet flow. Can be used to divert small volumes of water to stable outlets. Ineffective as a filter and should never be placed across streams or ditches where flow is concentrated.</p>	•				•	•	
27	 <p>PLASTIC SHEETS OR GEOTEXTILE COVER</p>	<p>Plastic Sheets can be used to create a liner in temporary channels. Can also be used to create a temporary cover to prevent erosion of stockpiled materials.</p>	•	•	•			•	
28	 <p>MULCHING AND MULCH ANCHORING</p>	<p>Anchored mulch provides erosion protection against rain and wind. Mulch must be used on seeded areas to promote water retention and growth. Should be inspected after every rainstorm and repaired as necessary until vegetation is well established.</p>	•		•		•	•	
29	 <p>INLET PROTECTION FABRIC DROP</p>	<p>Provides settling and filtering of silt laden water prior to its entry into the drainage system. Can be used in median and side ditches where vegetation will be disturbed. Allows for early use of drainage systems prior to project completion.</p>			•		•		
30	 <p>INLET PROTECTION GEOTEXTILE AND STONE</p>	<p>Provides settling and filtering of silt laden water prior to its entry into the drainage system. Should be used in paved areas where drainage structures are existing or proposed. Allows for early use of drainage systems prior to project completion.</p>			•		•		

MICHIGAN DEPARTMENT OF TRANSPORTATION
BUREAU OF HIGHWAY DEVELOPMENT STANDARD PLAN FOR



**SOIL EROSION & SEDIMENTATION
CONTROL MEASURES**

9-10-2010
F.H.W.A. APPROVAL

6-3-2010
PLAN DATE

R-96-E

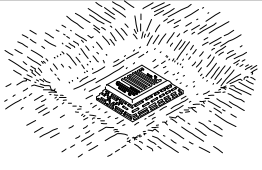
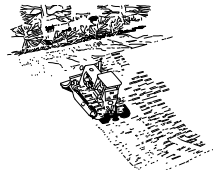
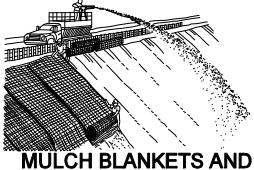
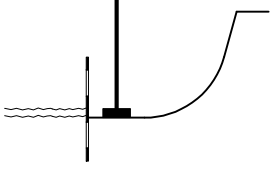
SHEET
4 OF 6

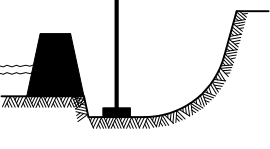
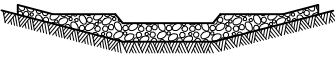
KEY	DETAIL	CHARACTERISTICS	A	B	C	D	E	F	G
31	 <p>INLET PROTECTION SEDIMENT TRAP</p>	<p>An Inlet Protection Sediment Trap is a temporary device that can be used in areas where medium flows are anticipated. Effective in trapping small quantities of sediments prior to water entering the drainage system. Can be used in areas such as median and side ditches.</p>			•		•		
32	 <p>SLOPE ROUGHENING AND SCARIFICATION</p>	<p>A simple and economical way to reduce soil erosion by wind and water. Can be accomplished by harrowing with a disk, back blading, or tracking with a dozer perpendicular to the slope.</p>	•				•	•	
33	 <p>MULCH BLANKETS AND HIGH VELOCITY MULCH BLANKETS</p>	<p>Mulch blankets provide an immediate and effective cover over raw erodible slopes affording excellent protection against rain and wind erosion. High velocity mulch blankets work well for stabilizing the bottom of ditches in waterways.</p>	•		•		•	•	
34	 <p>COFFERDAM</p>	<p>Used to create a dry construction area and protect the stream from raw erodible areas. Must be pumped dry or dewatered according to DEWATERING WITH FILTER BAG (KEY 18).</p>		•					•
35	 <p>TEMPORARY BYPASS CHANNEL</p>	<p>Utilized when a dry construction area is needed. Isolates stream flows from raw erodible areas minimizing erosion and subsequent siltation. Can incorporate SEDIMENT BASIN (KEY 21), CHECK DAM (KEY 37), and GRAVEL FILTER BERM (KEY 13) to remove sediments from water. Construction sequence of events may be necessary.</p>		•					•
36	 <p>CONSTRUCTION DAM</p>	<p>Used to create a dry or slack water area for construction. Isolates the stream from raw erodible areas. Can be created out of any non-erodible materials such as SAND AND STONE BAGS (KEY 24), a gravel dike with clay core or plastic liner, steel plates or plywood.</p>		•					•
37	 <p>CHECK DAM</p>	<p>Can be constructed across ditches or any area of concentrated flow. Protects vegetation in early stages of growth. A Check Dam is intended to reduce water velocities and capture sediment. A Check Dam is not a filtering device.</p>	•		•			•	

MICHIGAN DEPARTMENT OF TRANSPORTATION
BUREAU OF HIGHWAY DEVELOPMENT STANDARD PLAN FOR

**SOIL EROSION & SEDIMENTATION
CONTROL MEASURES**

9-10-2010
F.H.W.A. APPROVAL

6-3-2010
PLAN DATE

R-96-E

SHEET
5 OF 6

NOTES:

THIS STANDARD PLAN WILL SERVE AS A KEY IN THE SELECTION OF THE APPROPRIATE SOIL EROSION AND SEDIMENTATION CONTROL DETAILS. THIS PLAN ALSO PROVIDES THE KEY TO THE NUMBERED EROSION CONTROL ITEMS SPECIFIED ON THE CONSTRUCTION PLANS. REFER TO THE MDOT SOIL EROSION & SEDIMENTATION CONTROL MANUAL, SECTION 6 FOR SPECIFIC DETAILS, CONTRACT ITEMS (PAY ITEMS), AND PAY UNITS.

COLLECTED SILT AND SEDIMENT SHALL BE REMOVED PERIODICALLY TO MAINTAIN THE EFFECTIVENESS OF THE SEDIMENT TRAP, SEDIMENT BASIN, AND SILT FENCE. AGGREGATES PLACED IN STREAMS SHOULD CONTAIN A MINIMUM OF FINES.

TEMPORARY EROSION AND SEDIMENTATION CONTROL PROVISIONS SHALL BE COORDINATED WITH THE PERMANENT CONTROL MEASURES TO ASSURE EFFECTIVE CONTROL OF SEDIMENTS DURING CONSTRUCTION OF THE PROJECT.

ALL TEMPORARY EROSION CONTROL DEVICES SHALL BE REMOVED AFTER VEGETATION ESTABLISHMENT OR AT THE DISCRETION OF THE ENGINEER. CARE SHALL BE TAKEN DURING REMOVAL TO MINIMIZE SILTATION IN NEARBY DRAINAGE COURSES.

MICHIGAN DEPARTMENT OF TRANSPORTATION
BUREAU OF HIGHWAY DEVELOPMENT STANDARD PLAN FOR

**SOIL EROSION & SEDIMENTATION
CONTROL MEASURES**

9-10-2010
F.H.W.A. APPROVAL

6-3-2010
PLAN DATE

R-96-E

SHEET
6 OF 6

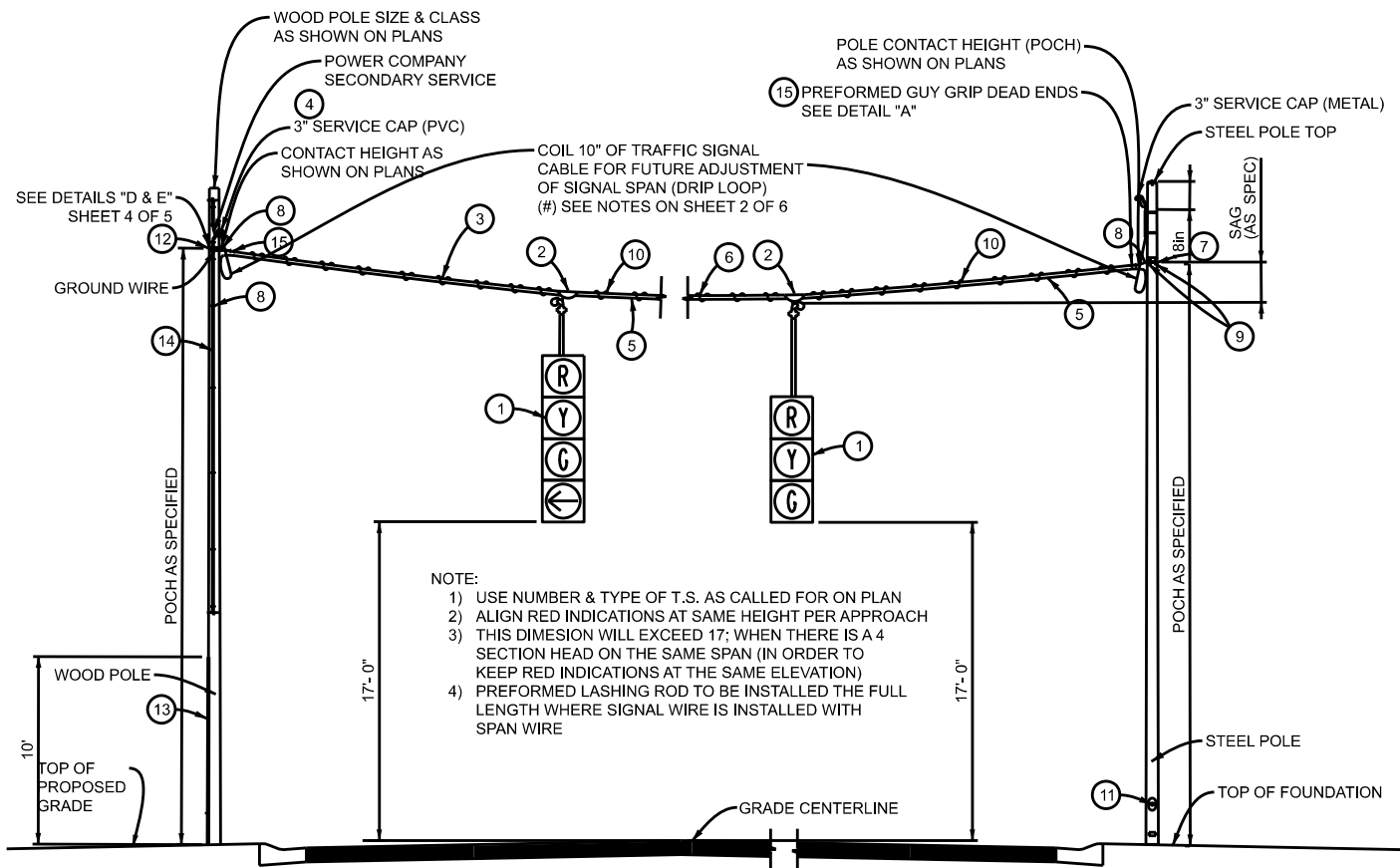

NOTE:
 1) USE NUMBER & TYPE OF T.S. AS CALLED FOR ON PLAN
 2) ALIGN RED INDICATIONS AT SAME HEIGHT PER APPROACH
 3) THIS DIMENSION WILL EXCEED 17'; WHEN THERE IS A 4 SECTION HEAD ON THE SAME SPAN (IN ORDER TO KEEP RED INDICATIONS AT THE SAME ELEVATION)
 4) PREFORMED LASHING ROD TO BE INSTALLED THE FULL LENGTH WHERE SIGNAL WIRE IS INSTALLED WITH SPAN WIRE

1 DETAIL - TYPICAL SPAN WIRE INSTALLATION T.S.
 NTS STEEL POLE & WOOD POLES

NO.	ITEM
1	TRAFFIC SIGNAL (NO. HEADS AS INDICATED)
2	SPAN WIRE HANGER
3	5/16" EXTRA HIGH STRENGTH SPAN WIRE
4	3" SERVICE CAP (WEATHERHEAD), (METAL FOR STEEL AND PVC FOR WOOD POLES)
5	P.J. TRAFFIC SIGNAL CABLE (AS SPECIFIED)
6	PREFORMED LASHING RODS
7	POLE BAND CLAMP (STEEL POLE)
8	GUY THIMBLE (2" DIA.)
9	(2) 5/8" X 4" LONG BOLT, NUT, WASHERS PER POLE BAND CLAMP (STEEL POLE)
10	INSTALL SPAN WIRE PREFORMED (ARMOR ROD) UNDER EACH SPAN HANGER
11	ACCESS HAND HOLE ALL NEW & EXISTING STEEL POLES
12	5/8" EYEBOLT, OVAL EYE AND NUT
13	WOOD MOULDING OR PLASTIC DUCT (10' FROM GROUND LEVEL)
14	3" SCHEDULE 80 PVC OR RIGID METAL (*) SEE NOTE ON SHEET 2 OF 5
15	PREFORMED GUY GRIP DEAD ENDS

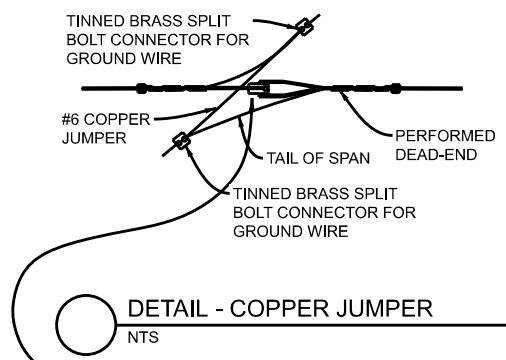

DETAIL - COPPER JUMPER
 NTS

NOTE:
 PORCELAIN STRAIN INSULATOR (IF REQUIRED) SHALL MEET THE CODES AND PLACEMENT REQUIREMENTS OF THE LOCAL UTILITY CO.

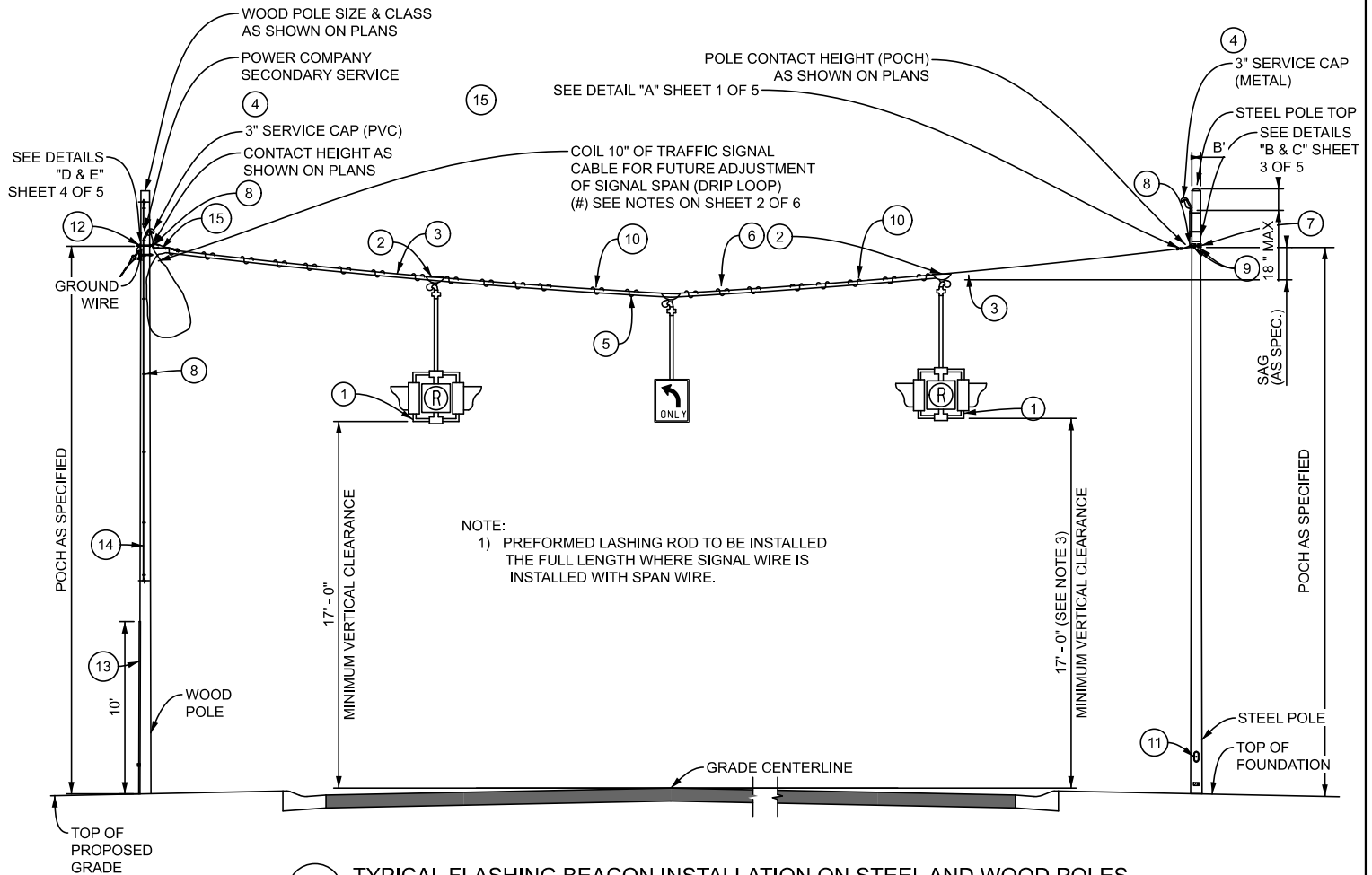

1 TYPICAL FLASHING BEACON INSTALLATION ON STEEL AND WOOD POLES
NTS

NO.	ITEM
1	TRAFFIC SIGNAL (NO. HEADS AS INDICATED)
2	SPAN WIRE HANGER
3	5/16" EXTRA HIGH STRENGTH SPAN WIRE
4	3" SCHEDULE 80 PVC OR RIGID METAL (*) SEE NOTE ON SHEET 2 OF 5
5	P.J. TRAFFIC SIGNAL CABLE (AS SPECIFIED)
6	PREFORMED LASHING RODS
7	POLE BAND CLAMP (STEEL POLE)
8	GUY THIMBLE (2" DIA.)
9	(2) 5/8" X 4" LONG BOLT, NUT, WASHERS PER POLE BAND CLAMP (STEEL POLE)
10	INSTALL SPAN WIRE PREFORMED (ARMOR ROD) UNDER EACH SPAN HANGER
11	ACCESS HAND HOLE ALL NEW & EXISTING STEEL POLES
12	5/8" EYEBOLT, OVAL EYE AND NUT
13	WOOD MOULDING OR PLASTIC DUCT (10' FROM GROUND LEVEL)
14	3" SERVICE CAP (WEATHERHEAD), (METAL FOR STEEL AND PVC FOR WOOD POLES)
15	PREFORMED GUY GRIP DEAD ENDS

NOTES:
 (*) FOR PROJECTS MAINTAINED BY THE WAYNE CO. DEPARTMENT OF PUBLIC SERVICES (WCDPS), USE RIGID METAL FOR CONDUIT(S) FROM GRADE LEVEL TO 10' (MIN.) ABOVE GRADE OR AS DIRECTED BY THE ENGINEER.

(#) FOR PROJECTS MAINTAINED BY THE ROAD COMMISSION FOR OAKLAND COUNTY (RCOC), USE DRIP LOOP (WITHOUT COIL) FOR FUTURE ADJUSTMENT OF SIGNAL SPAN.



DEPARTMENT DIRECTOR
BRADLEY C. WIEFERICH, PE

STANDARD PLAN FOR
SPAN WIRE CASING DETAILS

(SPECIAL DETAIL)
FHWA APPROVAL

07/27/23
PLAN DATE

SIG-010-A

SHEET
2 OF 7

SECT

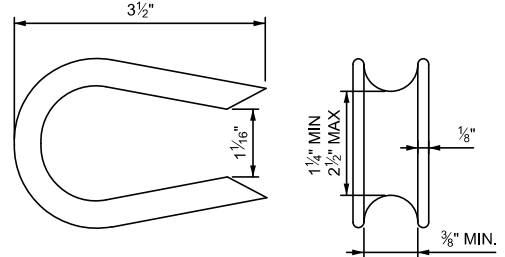
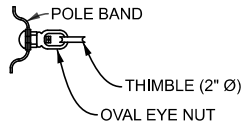
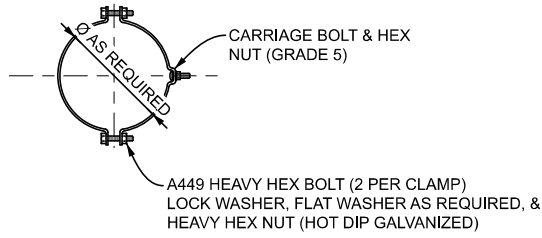
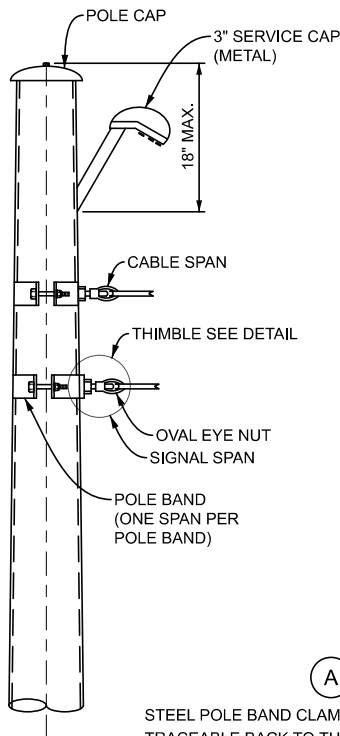

A DETAIL - POLE BAND CLAMP ON STEEL POLE

B DETAIL - THIMBLE

STEEL POLE BAND CLAMPS MUST BE STAMPED WITH IDENTIFICATION THAT IS TRACEABLE BACK TO THE MANUFACTURER, WHICH CAN BE USED TO DETERMINE THE MONTH AND YEAR OF CLAMP MANUFACTURE. THE STAMPING METHOD MUST BE A LOW STRESS STAMPING METHOD. THE STAMP CANNOT BE LOCATED NEAR THE BOLTED FLANGE, MUST BE LOCATED NEAR THE CENTER OF THE CLAMP ON THE BACK SIDE FACING AWAY FROM TRAFFIC, AND BE VISIBLE AFTER GALVANIZING. ALL BEND RADII ARE TO BE A MINIMUM OF 1.5 TIMES THE POLE BAND THICKNESS.

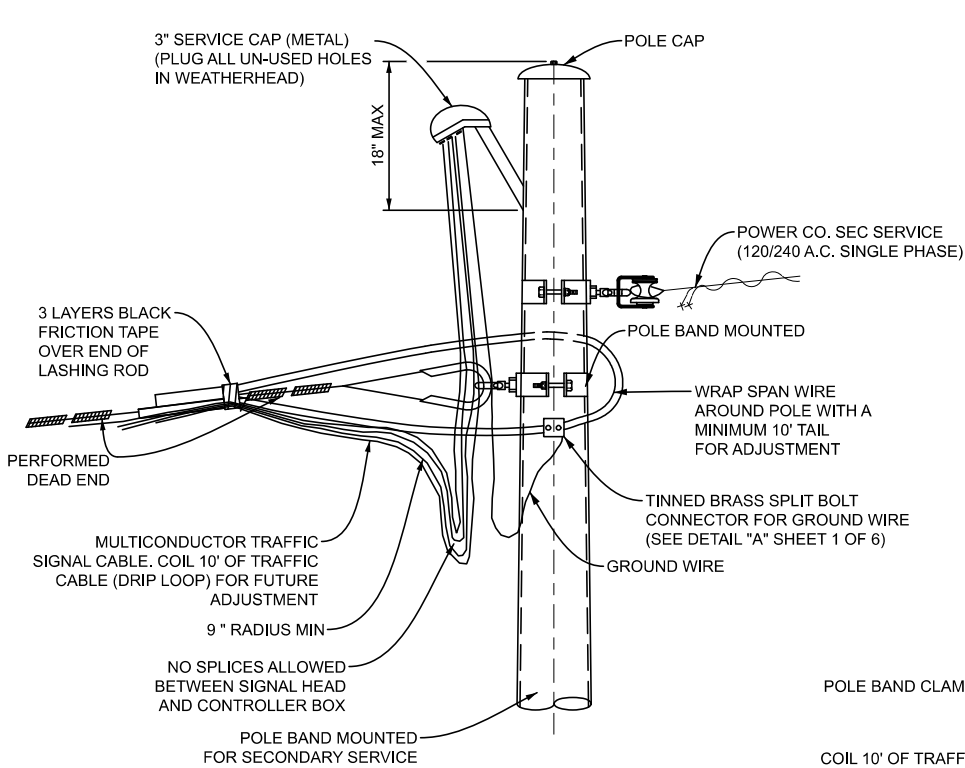

C DETAIL-CABLING ON STEEL POLE

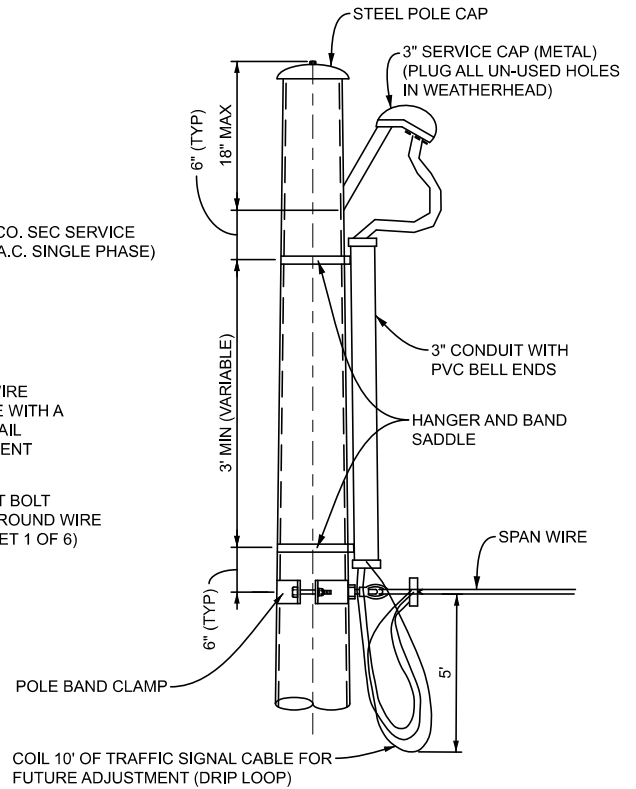

D DETAIL - SERVICE CABLE ON STEEL POLE

 DEPARTMENT DIRECTOR BRADLEY C. WIEFERICH, PE	STANDARD PLAN FOR SPAN WIRE CASING DETAILS		SIG-010-A	SHEET 3 OF 7
	(SPECIAL DETAIL) FHWA APPROVAL	07/27/23 PLAN DATE		

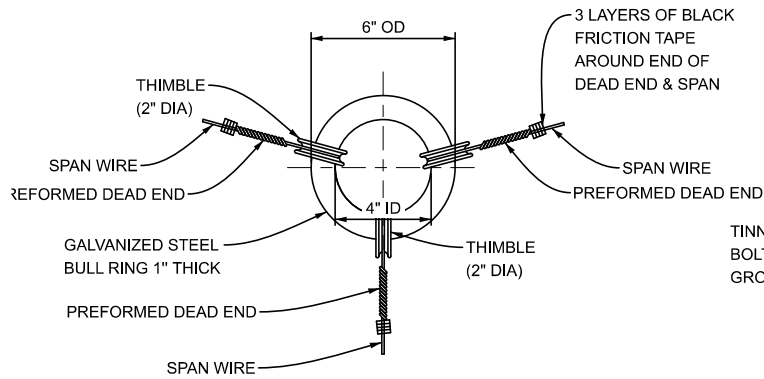

DETAIL
3-WAY TIE OFF BULL RING

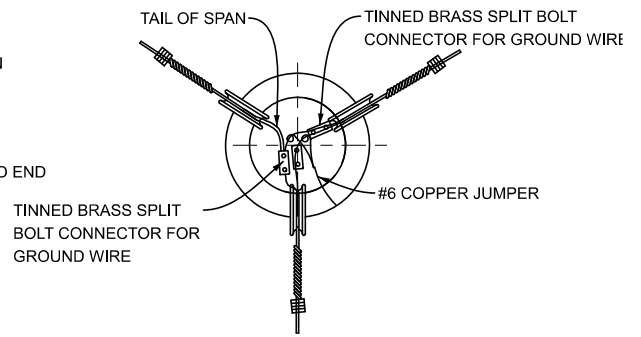

DETAIL COPPER JUMPER
3-WAY TIE OFF

NOTE:
PORCELAIN STRAIN INSULATOR (IF REQUIRED)
SHALL MEET THE CODES AND PLACEMENT
REQUIREMENTS OF THE LOCAL UTILITY CO.

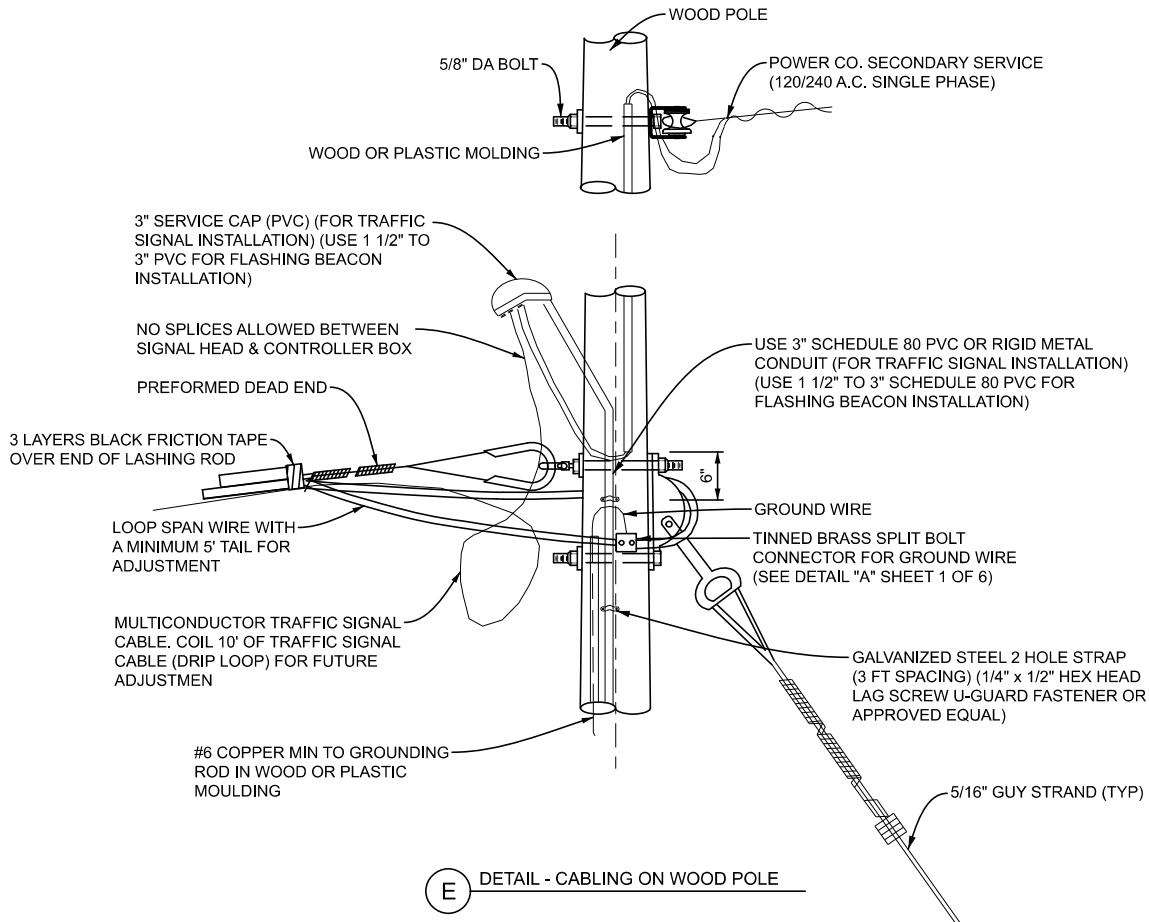

E **DETAIL - CABLING ON WOOD POLE**

MDOT
Michigan Department of Transportation

DEPARTMENT DIRECTOR
BRADLEY C. WIEFERICH, PE

STANDARD PLAN FOR SPAN WIRE CASING DETAILS			
(SPECIAL DETAIL)	07/27/23	SIG-010-A	SHEET
FHWA APPROVAL	PLAN DATE		4 OF 7

SECT

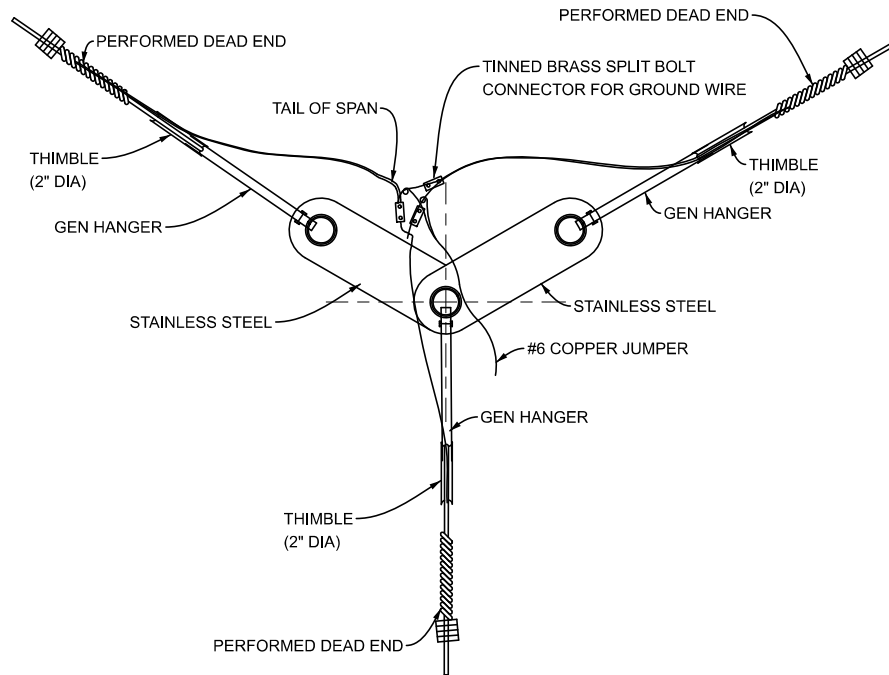

**DETAIL COPPER JUMPER
3-WAY TIE OFF**

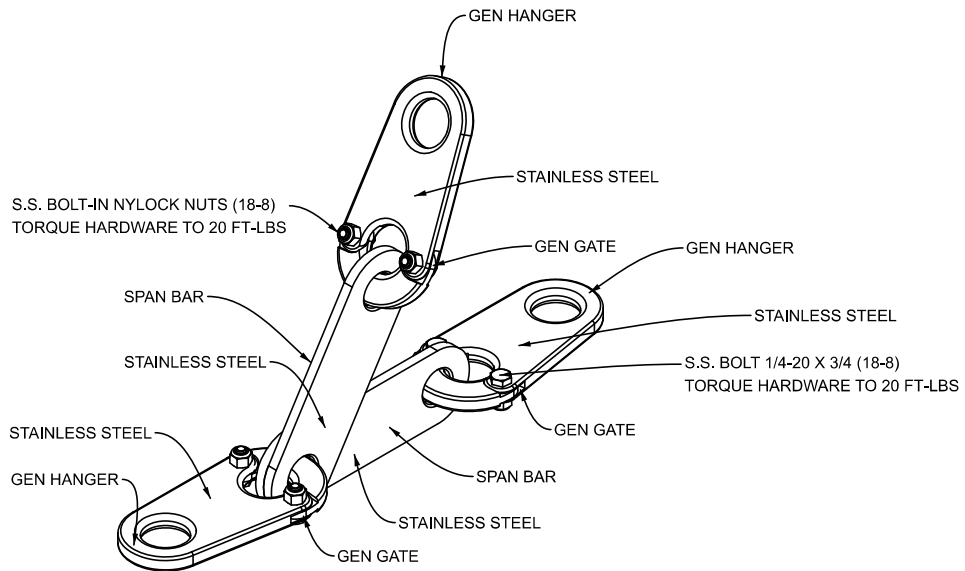

DETAIL SPAN HANGER ASSEMBLY (ALTERNATE)

<p>MDOT Michigan Department of Transportation</p> <p>DEPARTMENT DIRECTOR BRADLEY C. WIEFERICH, PE</p>	<p>STANDARD PLAN FOR SPAN WIRE CASING DETAILS</p>			<p>SHEET 5 OF 7</p>
	<p>(SPECIAL DETAIL) FHWA APPROVAL</p>	<p>07/27/23 PLAN DATE</p>	<p>SIG-010-A</p>	

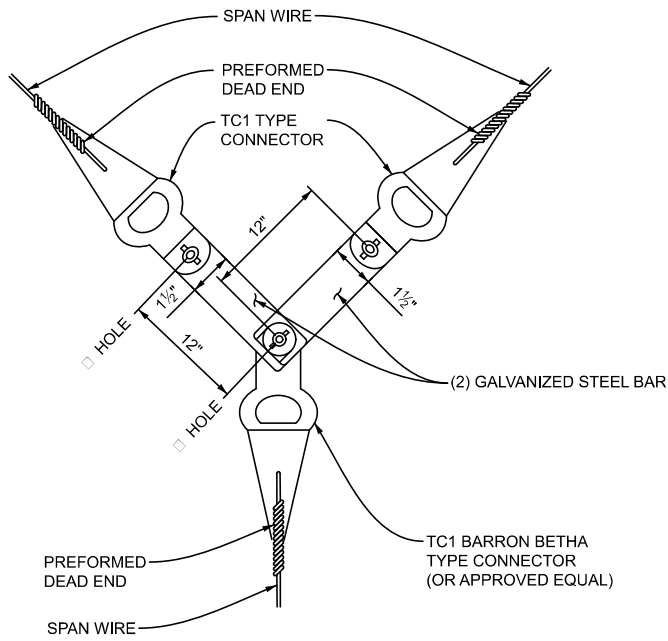

PULL-OFF CONNECTION DETAIL (ALTERNATE)
FOR 3-WAY SUSPENSION

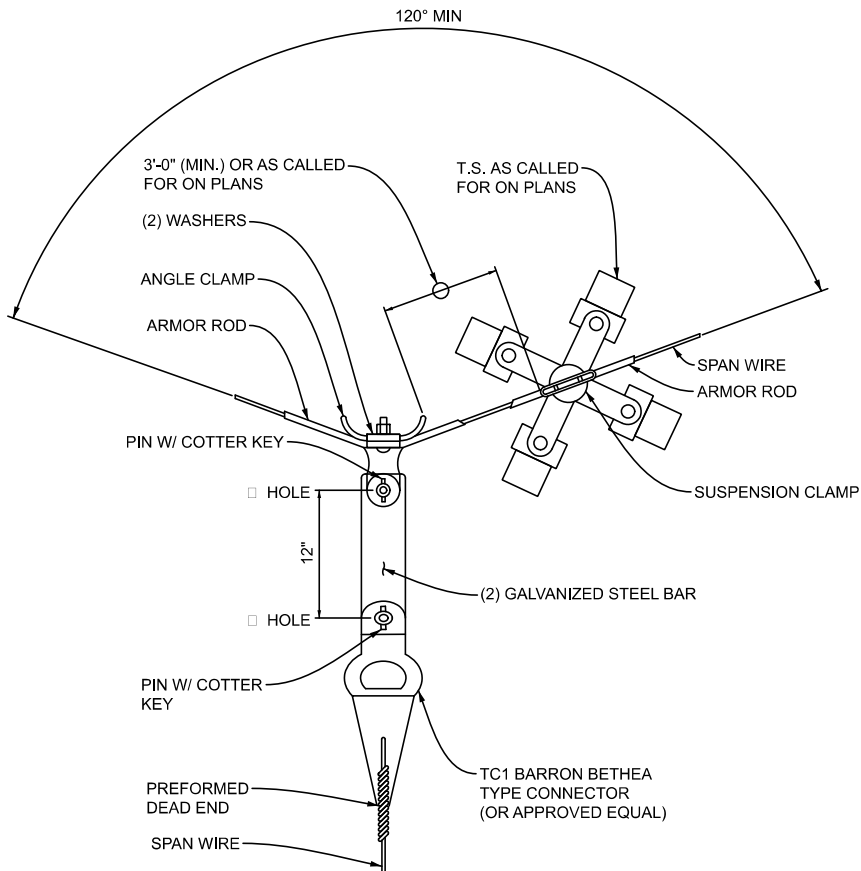

PULL-OFF CONNECTION DETAIL (ALTERNATE)
FOR 3-WAY SUSPENSION

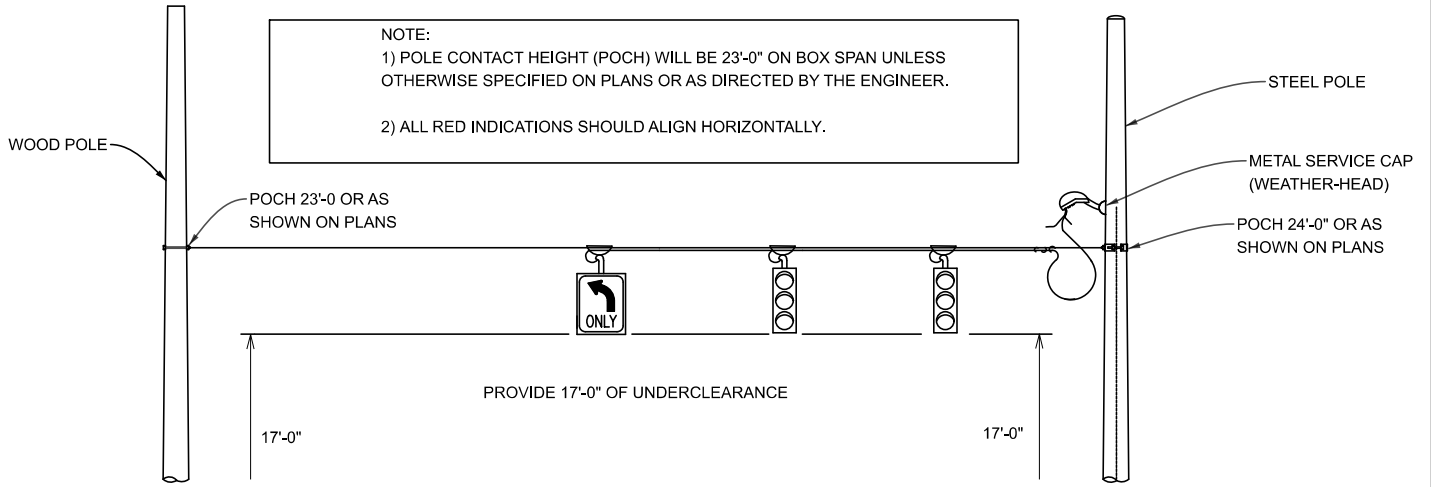

DETAIL INSTALLATION OF BOX SPAN WIRE T.S. ON STEEL OR WOOD POLES

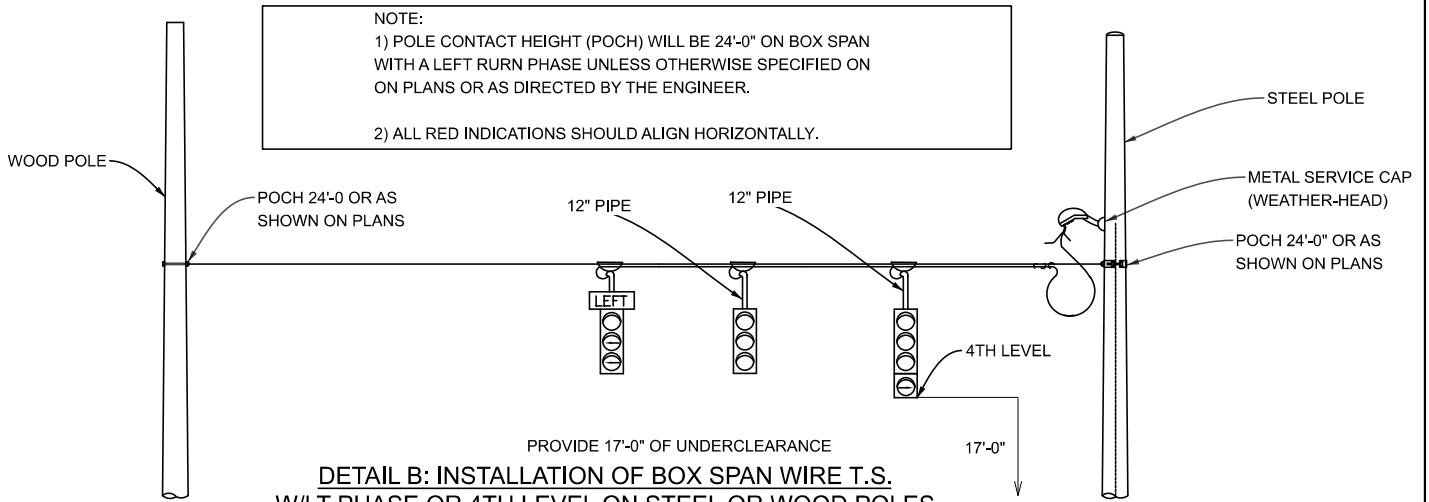

DETAIL B: INSTALLATION OF BOX SPAN WIRE T.S. W/LT PHASE OR 4TH LEVEL ON STEEL OR WOOD POLES

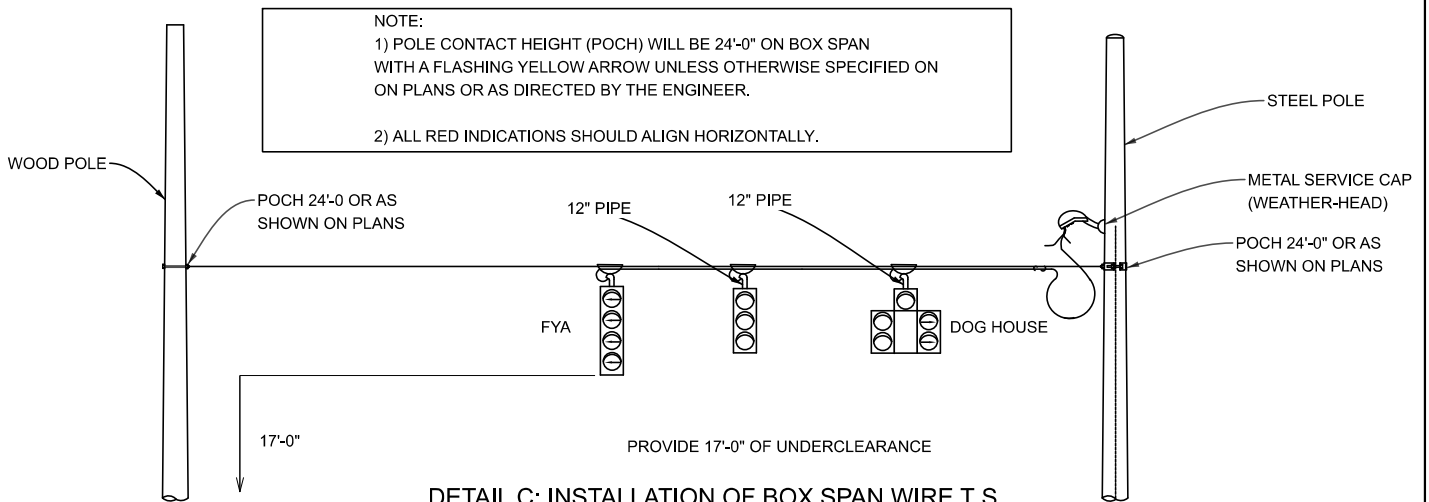

DETAIL C: INSTALLATION OF BOX SPAN WIRE T.S. FYA AND DOGHOUSE ON STEEL OR WOOD POLES

BOX SPAN WIRE T.S ON STEEL OR WOOD POLES FOR USE ON OAKLAND COUNTY ROADS ONLY



DEPARTMENT DIRECTOR
BRADLEY C. WIEFERICH, PE

STANDARD PLAN FOR
SPAN WIRE CASING DETAILS

(SPECIAL DETAIL)
FHWA APPROVAL

07/27/23
PLAN DATE

SIG-010-A

SHEET
7 OF 7

SECT

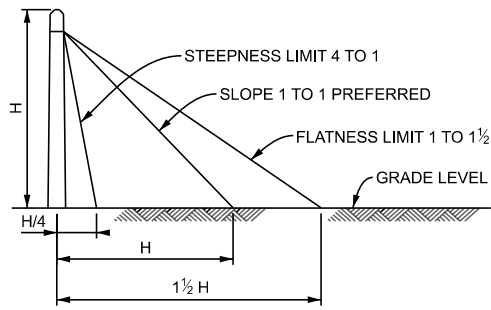

A DETAIL - ANCHOR GUY SLOPE LIMITS
N.T.S.

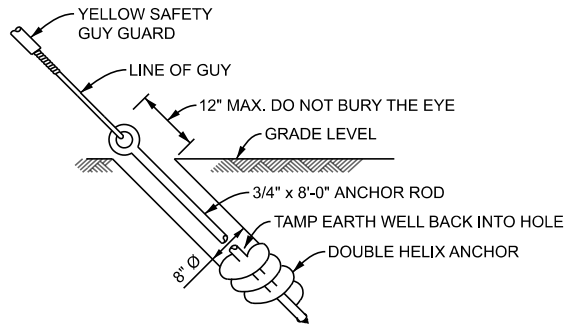

NOTE:

1. USE DOUBLE HELIX ANCHOR ACCORDING TO SOIL CONDITION AS DIRECTED BY THE ENGINEER.

B DETAIL - GUY ANCHOR
N.T.S.

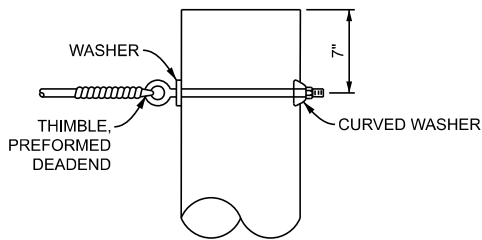

C DETAIL - POLE GUY
N.T.S.

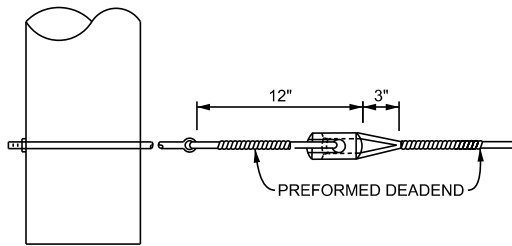

E DETAIL - ARM GUY
N.T.S.

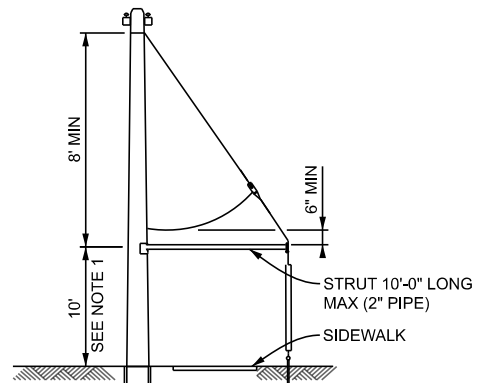

NOTE:

1. THIS DIMENSION TO BE 10' UNLESS OTHERWISE SPECIFIED.

D DETAIL - GUY STRUT
N.T.S.

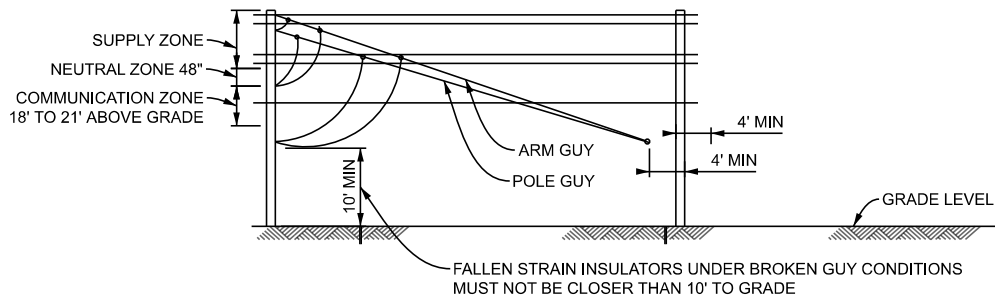

F DETAIL - STRAIN INSULATOR POSITIONS IN GUY WIRES
N.T.S.

APPROVED BY: _____
DIRECTOR, BUREAU OF FIELD SERVICES

APPROVED BY: _____
DIRECTOR, BUREAU OF DEVELOPMENT



DEPARTMENT DIRECTOR
BRADLEY C. WIEFERICH, PE

STANDARD PLAN FOR
WOOD POLE GUYS
AND SETTING DEPTH

(SPECIAL DETAIL)
FHWA APPROVAL

10/29/2024
PLAN DATE

SIG-050-A

SHEET
1 OF 2

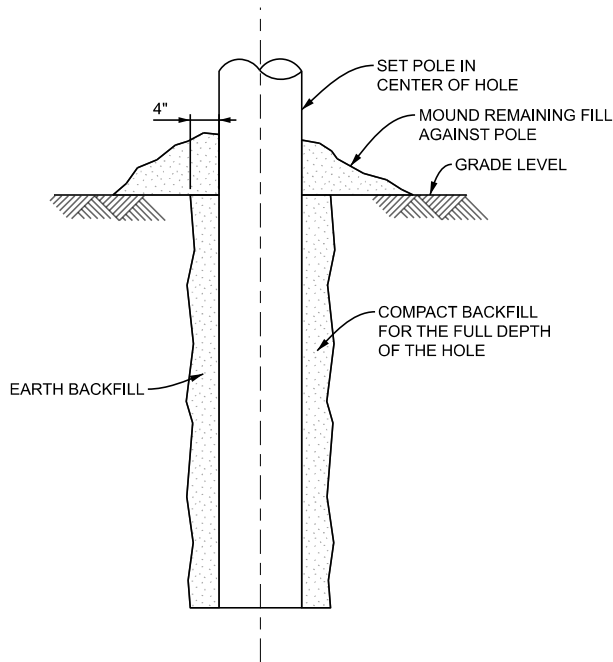

G DETAIL - WOOD POLE INSTALLATION
N.T.S.

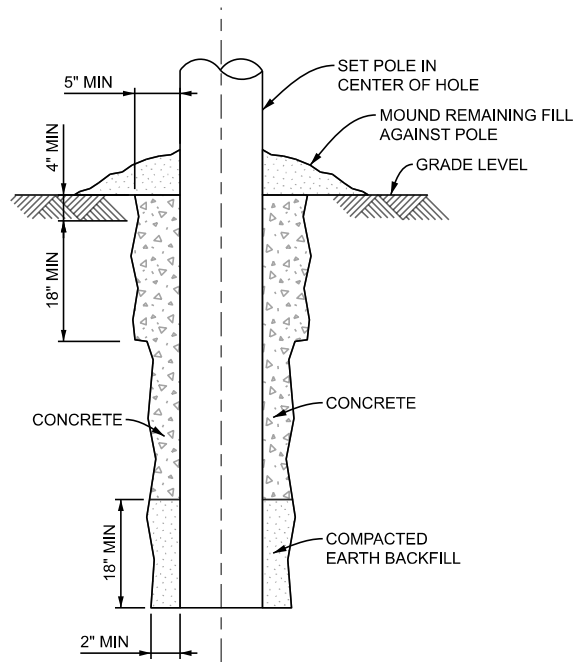

H SELF SUPPORTING
DETAIL - WOOD POLE IN CONCRETE
N.T.S.

WOOD POLE SETTING DEPTHS	
POLE HEIGHT	SETTING DEPTH
30'	6.0'
35'	6.0'
40'	6.0'
45'	6.5'
50'	7.0'
55'	7.5'
60'	8.0'

NOTES:

1. REFERENCE STANDARD SPECIFICATIONS FOR CONSTRUCTION SECTION 819.03.



DEPARTMENT DIRECTOR
BRADLEY G. WIEFERICH, PE

STANDARD PLAN FOR
WOOD POLE GUYS
AND SETTING DEPTH

(SPECIAL DETAIL)
FHWA APPROVAL

10/29/2024
PLAN DATE

SIG-050-A

SHEET
2 OF 2

ALUMINUM PEDESTAL 6063-T6 ALLOY,
4" X 0.237" WALL SCHEDULE 40-3.73 #/FT
SPUN FINISH

FRANGIBLE SQUARE ALUMINUM BASE
(SEE NOTE 4 SHEET 3 OF 3)

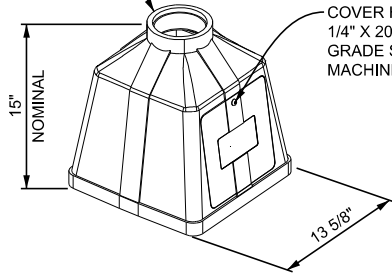
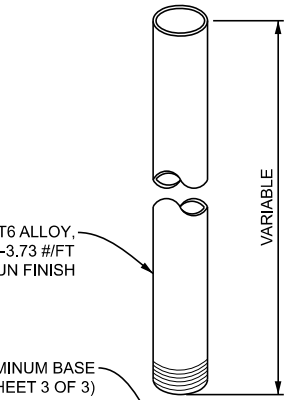

A DETAIL - SQUARE ALUMINUM BASE
N.T.S.

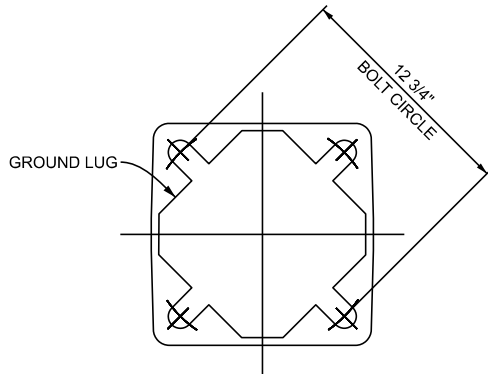

B DETAIL - SQUARE BASE BOTTOM PLAN
N.T.S.

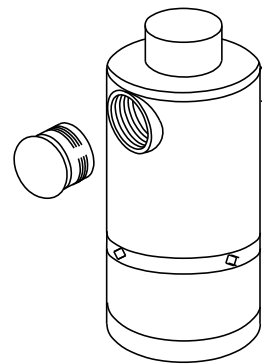

C POST TOP
DETAIL - (SLIP FITTER)
N.T.S.

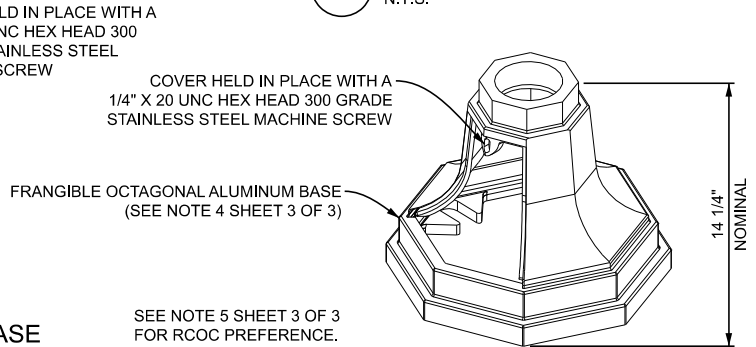

D DETAIL - OCTOGONAL BASE
N.T.S.

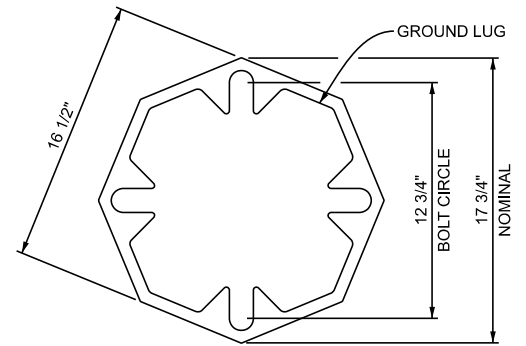

E DETAIL - OCTOGONAL BASE BOTTOM PLAN
N.T.S.

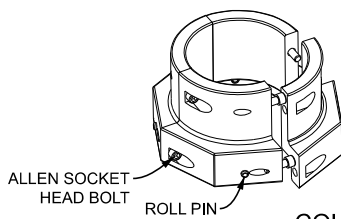

F COLLAR
DETAIL - (OCTOGANAL BASE)
N.T.S.

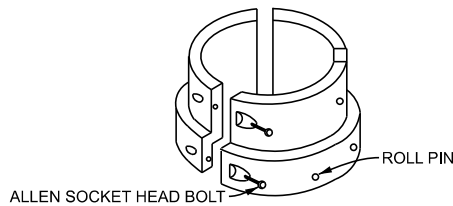

G COLLAR
DETAIL - (SQUARE BASE)
N.T.S.

NOTE:
USE PEDESTAL COLLAR FOR PEDESTAL LENGTH
GREATER THAN OR EQUAL TO 14' (TYPICAL FOR
3 COLOR TRAFFIC SIGNALS WITH PEDESTRIAN SIGNALS).

APPROVED BY: _____
DIRECTOR, BUREAU OF FIELD SERVICES

APPROVED BY: _____
DIRECTOR, BUREAU OF DEVELOPMENT



DEPARTMENT DIRECTOR
BRADLEY C. WIEFERICH, PE

STANDARD PLAN FOR
PEDESTAL FOUNDATION

(SPECIAL DETAIL)
FHWA APPROVAL

10/29/2024
PLAN DATE

SIG-070-A

SHEET
1 OF 3

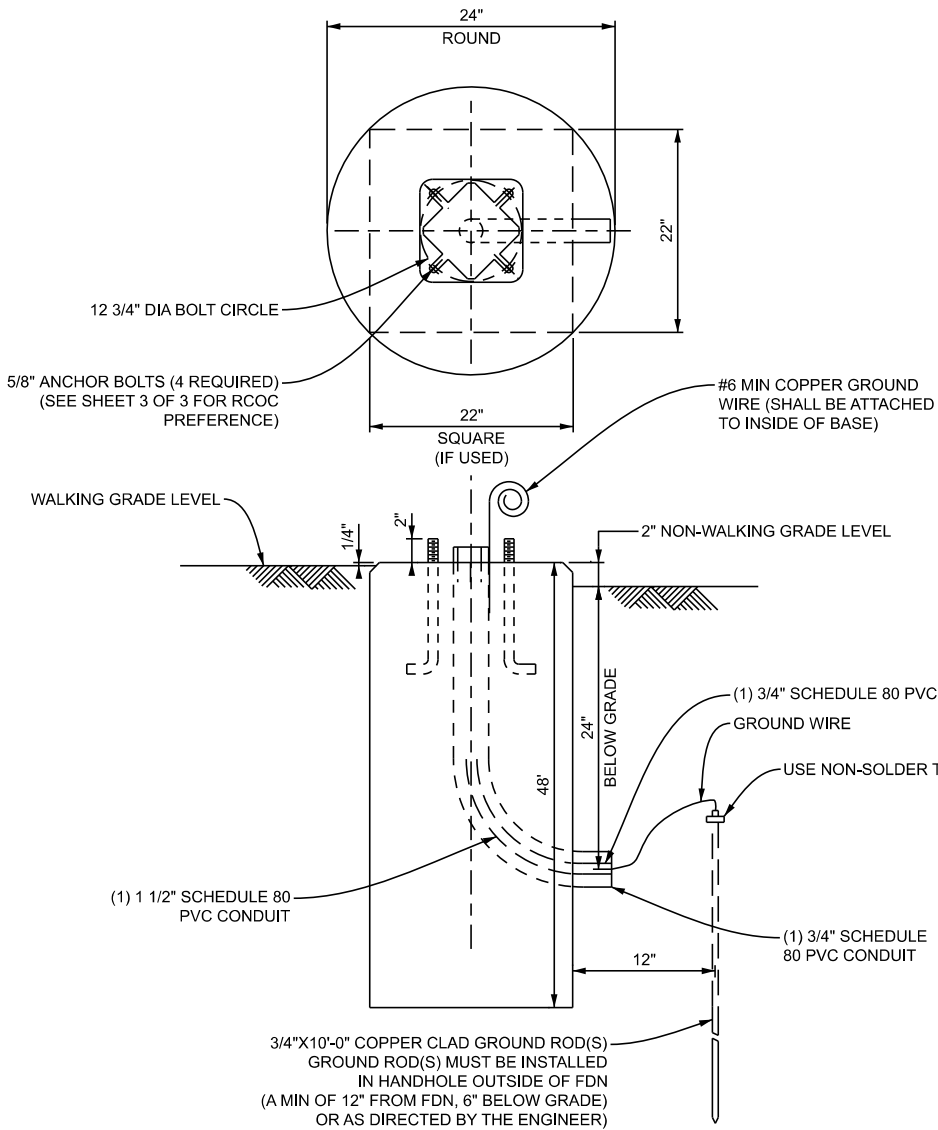

H **DETAIL - PEDESTAL FOUNDATION**
 N.T.S. SEE NOTES 1, 2 & 3 ON SHEET 3 OF 3

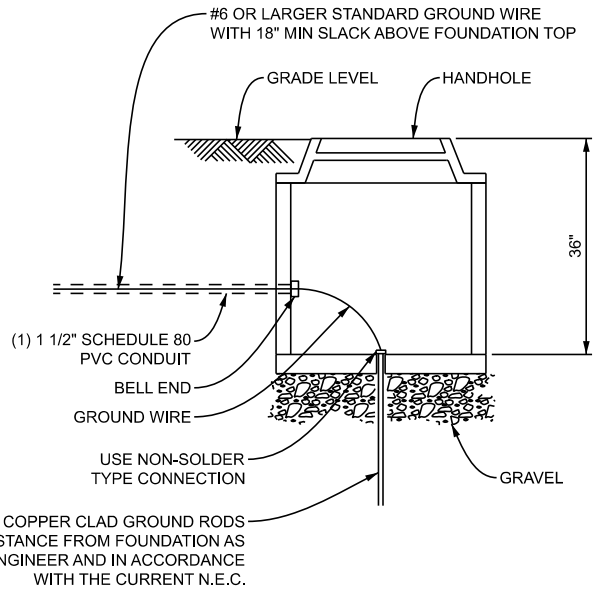

I **DETAIL - HANDHOLE**
 N.T.S.

 DEPARTMENT DIRECTOR BRADLEY C. WIEFERICH, PE	STANDARD PLAN FOR PEDESTAL FOUNDATION		SIG-070-A	SHEET 2 OF 3
	(SPECIAL DETAIL) FHWA APPROVAL	10/29/2024 PLAN DATE		

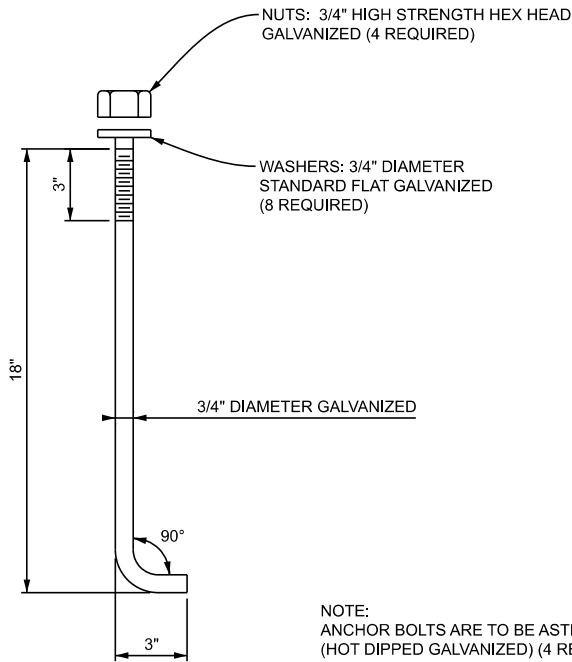

NOTE:
ANCHOR BOLTS ARE TO BE ASTM-F1554 GRADE 36
(HOT DIPPED GALVANIZED) (4 REQUIRED)

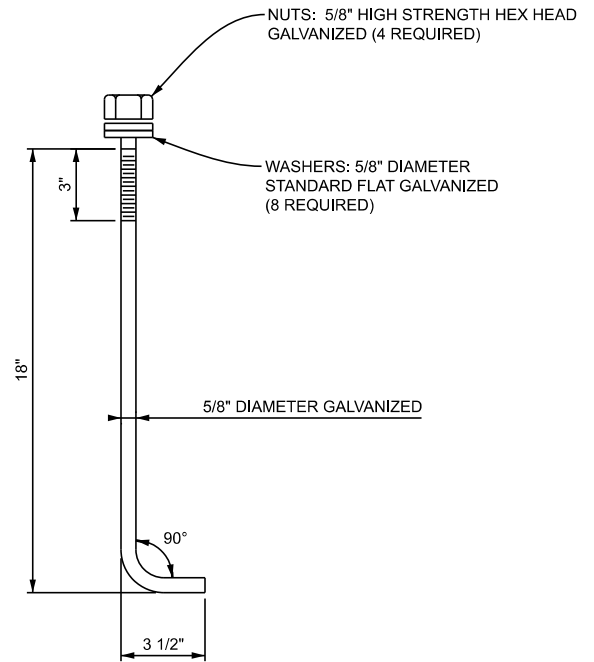

FOR USE ON MDOT TRUNKLINE

FOR USE ON OAKLAND COUNTY ROADS ONLY

J DETAIL - ANCHOR BOLT DETAIL
N.T.S.

NOTES:

- 1) ALTERNATE FOUNDATION MAY BE CONSTRUCTED 22"X22" SQUARE - 48" DEEP.
- 2) GROUNDING SYSTEM SHALL MEASURE 10 OHM OR LESS TO GROUND.
- 3) CONSTRUCTION JOINTS NOT PERMITTED IN FOUNDATION.
- 4) PEDESTAL BASE MUST MEET THE REQUIREMENTS OF NATIONAL COOPERATIVE HIGHWAY RESEARCH PROGRAM REPORT 350 (NCHRP 350) OR MANUAL FOR ASSESSING SAFETY HARDWARE (MASH) AND HAVE FEDERAL HIGHWAY ADMINISTRATION (FHWA) ACCEPTANCE. PEDESTAL BASE MUST ALSO BE CERTIFIED TO HAVE A 4-INCH MAXIMUM STUB HEIGHT AFTER THE SUPPORT HAS BROKEN AWAY FROM ITS BASE, AS SPECIFIED IN THE AASHTO STANDARD SPECIFICATIONS FOR STRUCTURAL SUPPORTS FOR HIGHWAY SIGNS, LUMINARIES, AND TRAFFIC SIGNALS AND THE AASHTO ROADSIDE DESIGN GUIDE.
- 5) USE THE OCTAGONAL BASE AS A PREFERENCE BY THE ROAD COMMISSION FOR OAKLAND COUNTY (RCOC), FOR USE ON OAKLAND COUNTY ROADS ONLY.

APPROVED BY: _____
DIRECTOR, BUREAU OF FIELD SERVICES

APPROVED BY: _____
DIRECTOR, BUREAU OF DEVELOPMENT



DEPARTMENT DIRECTOR
BRADLEY C. WIEFERICH, PE

STANDARD PLAN FOR
PEDESTAL FOUNDATION

(SPECIAL DETAIL)
FHWA APPROVAL

10/29/24
PLAN DATE

SIG-070-A

SHEET
3 OF 3

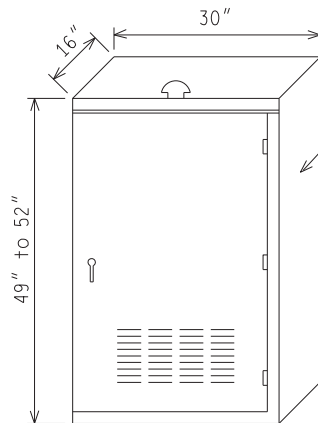

Vented aluminum cabinet with base mounting shall be Type NEMA 3R Size M-30

BASE MOUNTED TRAFFIC SIGNAL CONTROLLER CABINET

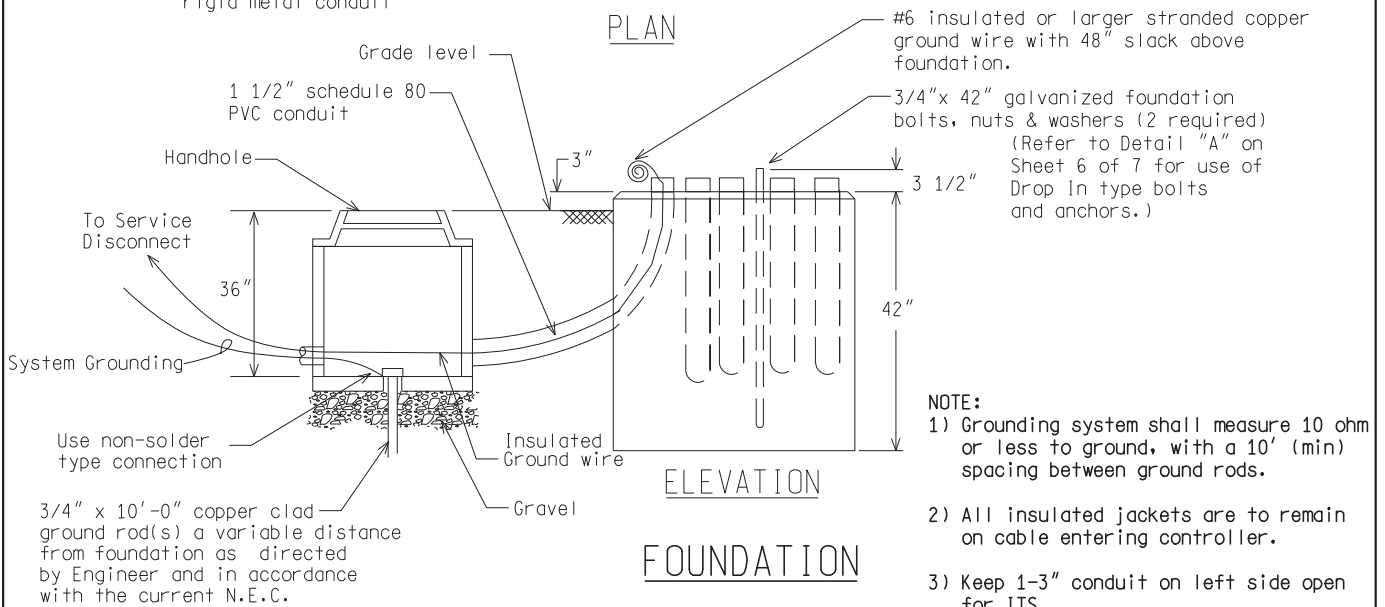
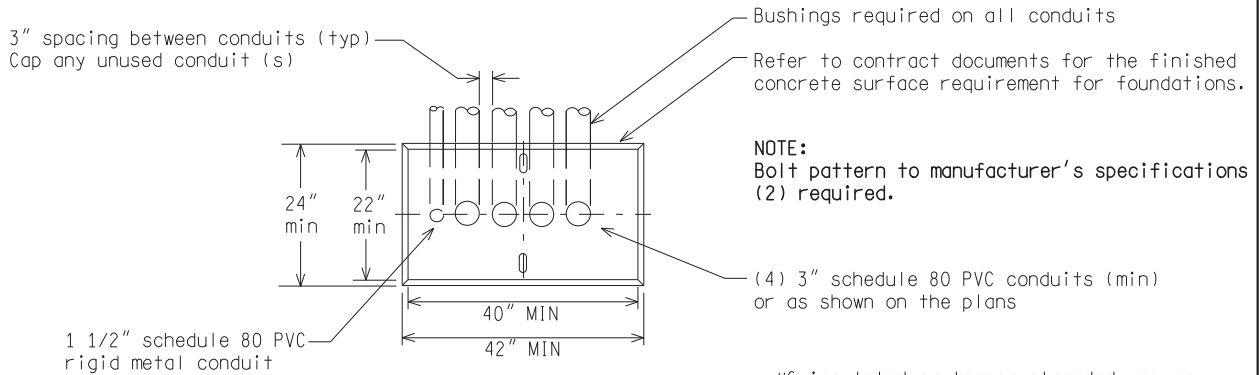

NOT TO SCALE

File: RefDoc/TR/Signals/Web/Sp Det/Fin/SIG110A.dgn Rev: 02/16/17



PREPARED BY
TRAFFIC AND SAFETY

DRAWN BY:

CHECKED BY:

ENGINEER OF DELIVERY

ENGINEER OF DEVELOPMENT

(SPECIAL DETAIL)

FHWA APPROVAL DATE

MICHIGAN DEPARTMENT OF TRANSPORTATION
BUREAU OF HIGHWAYS DELIVERY STANDARD PLAN FOR

BASE MOUNTED T.S.
CONTROLLER CABINET/FOUNDATIONS

PLAN DATE

SIG-110-A

SHEET
1 of 7

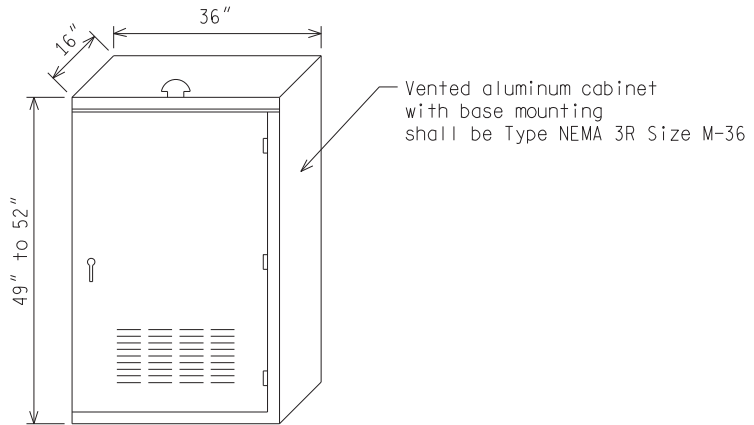

BASE MOUNTED TRAFFIC SIGNAL CONTROLLER CABINET

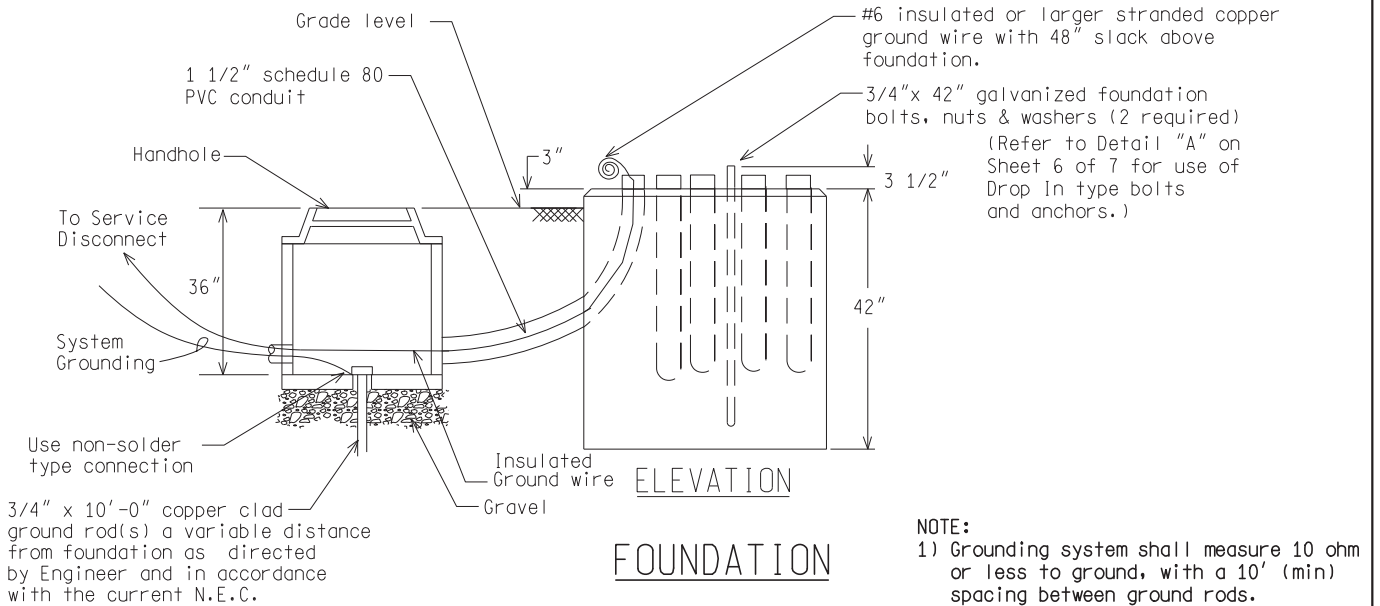
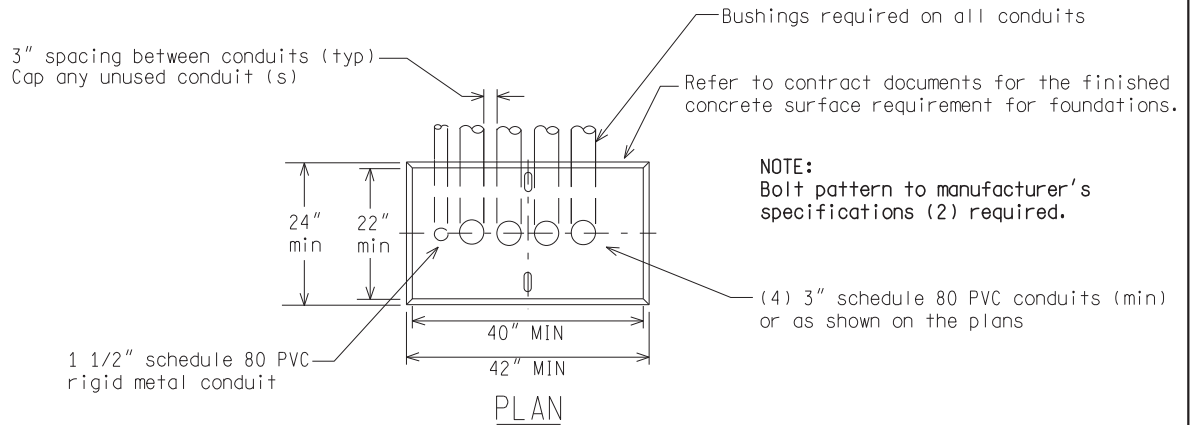

NOT TO SCALE

MICHIGAN DEPARTMENT OF TRANSPORTATION
BUREAU OF HIGHWAYS DELIVERY STANDARD PLAN

(SPECIAL DETAIL)
FHWA APPROVAL DATE

PLAN DATE

SIG-110-A

SHEET
2 of 7

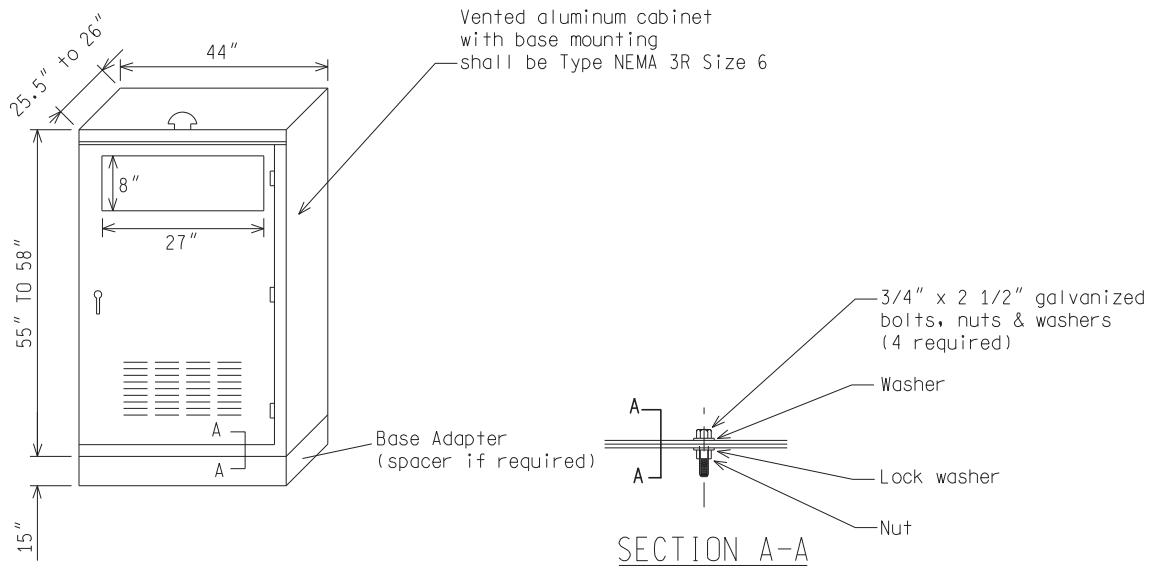

BASE MOUNTED TRAFFIC SIGNAL CONTROLLER CABINET

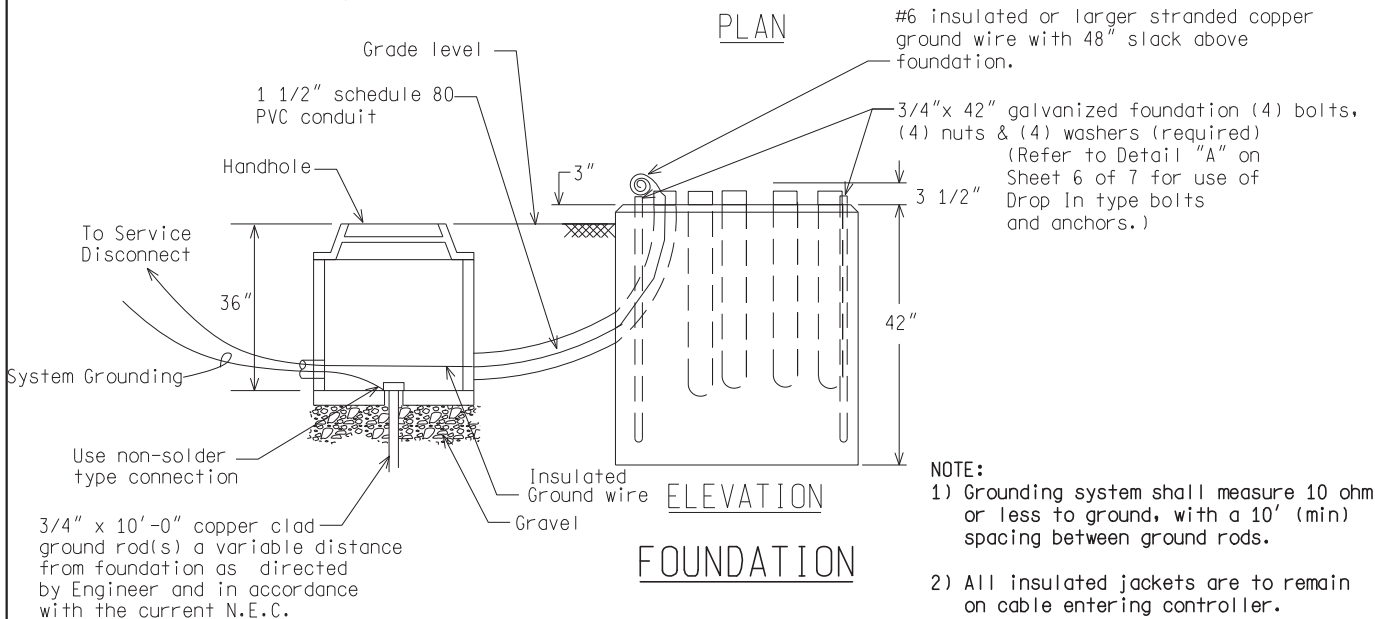
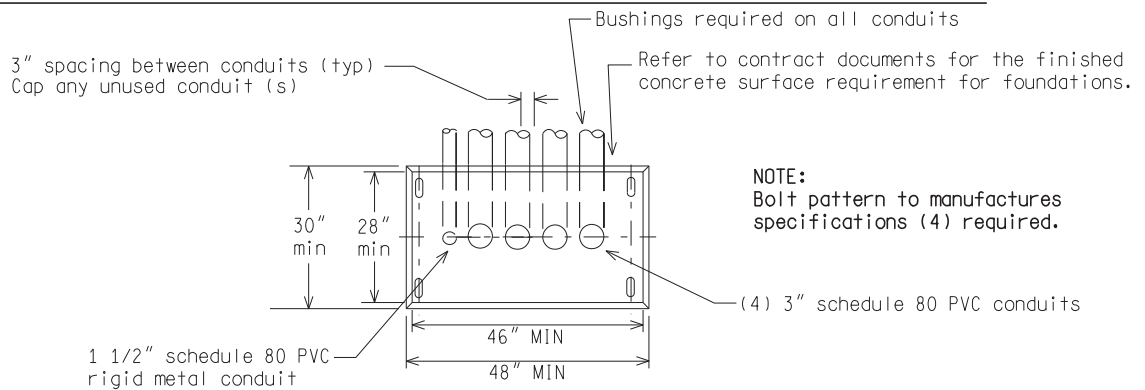

NOT TO SCALE

MICHIGAN DEPARTMENT OF TRANSPORTATION
BUREAU OF HIGHWAYS DELIVERY STANDARD PLAN

(SPECIAL DETAIL)
FHWA APPROVAL DATE

File:RefDoc/TR/Signals/Web/Sp Det/F in/SIG110A.dgn

Rev.02/16/17

PLAN DATE

SIG-110-A

SHEET
3 of 7

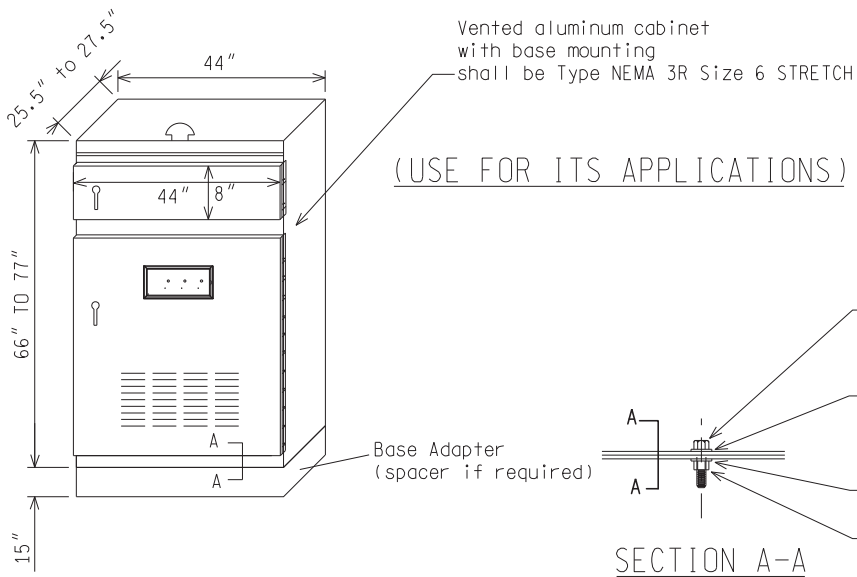

BASE MOUNTED TRAFFIC SIGNAL ITS CONTROLLER CABINET (IF USED)

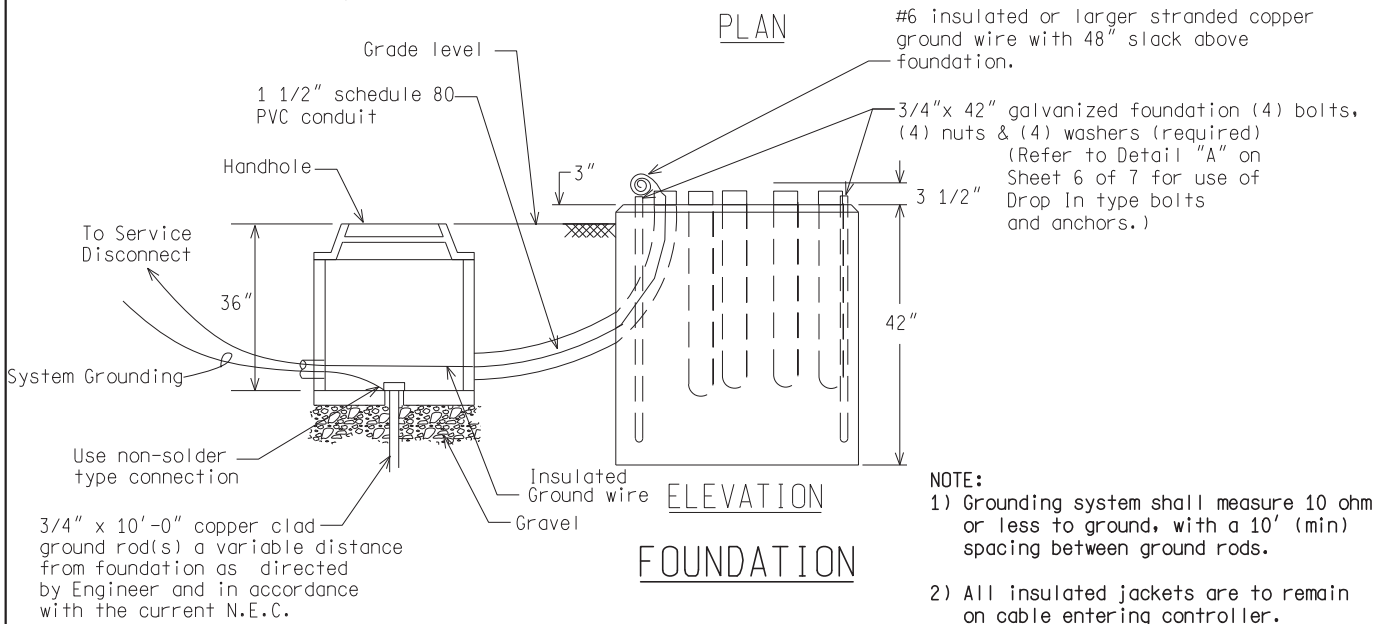
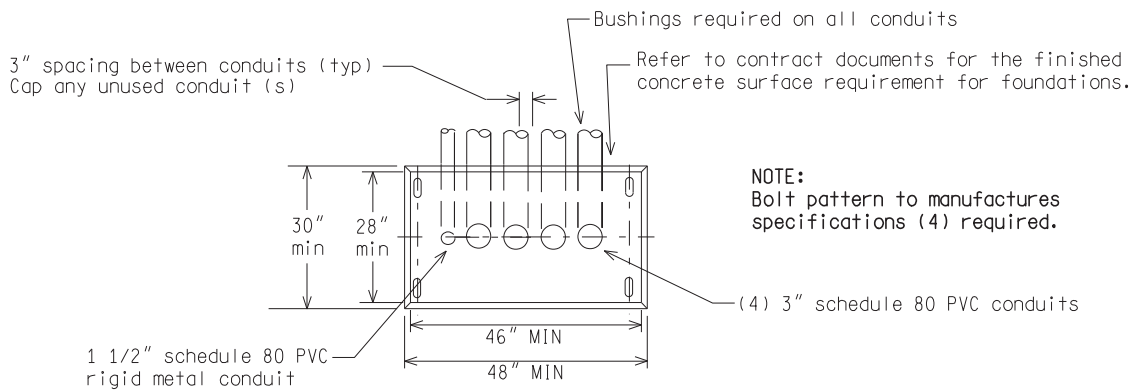

NOT TO SCALE

MICHIGAN DEPARTMENT OF TRANSPORTATION
BUREAU OF HIGHWAYS DELIVERY STANDARD PLAN

(SPECIAL DETAIL)
FHWA APPROVAL DATE

PLAN DATE

SIG-110-A

SHEET
4 of 7

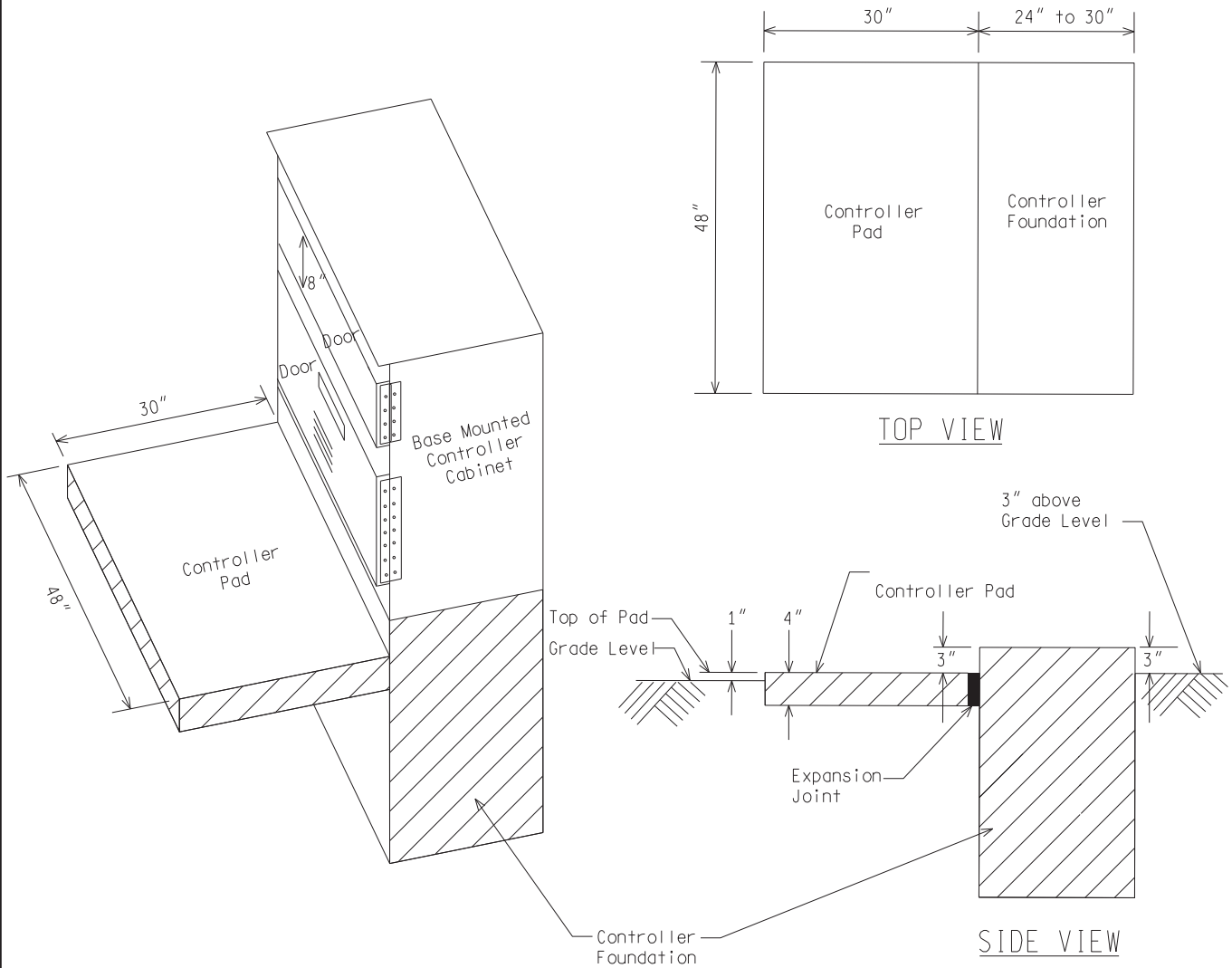

BASE MOUNTED CONTROLLER PAD

NOTE:
 Payment for controller pad to be included in controller foundation pay item.
 Controller cabinet door to open toward pad.

NOT TO SCALE

MICHIGAN DEPARTMENT OF TRANSPORTATION BUREAU OF HIGHWAYS DELIVERY STANDARD PLAN	(SPECIAL DETAIL) FHWA APPROVAL DATE		SIG-110-A	SHEET 5 of 7
File: RefDoc/TR/Signals/Web/Sp Det/Fin/SIG110A.dgn Rev. 02/16/17		PLAN DATE		

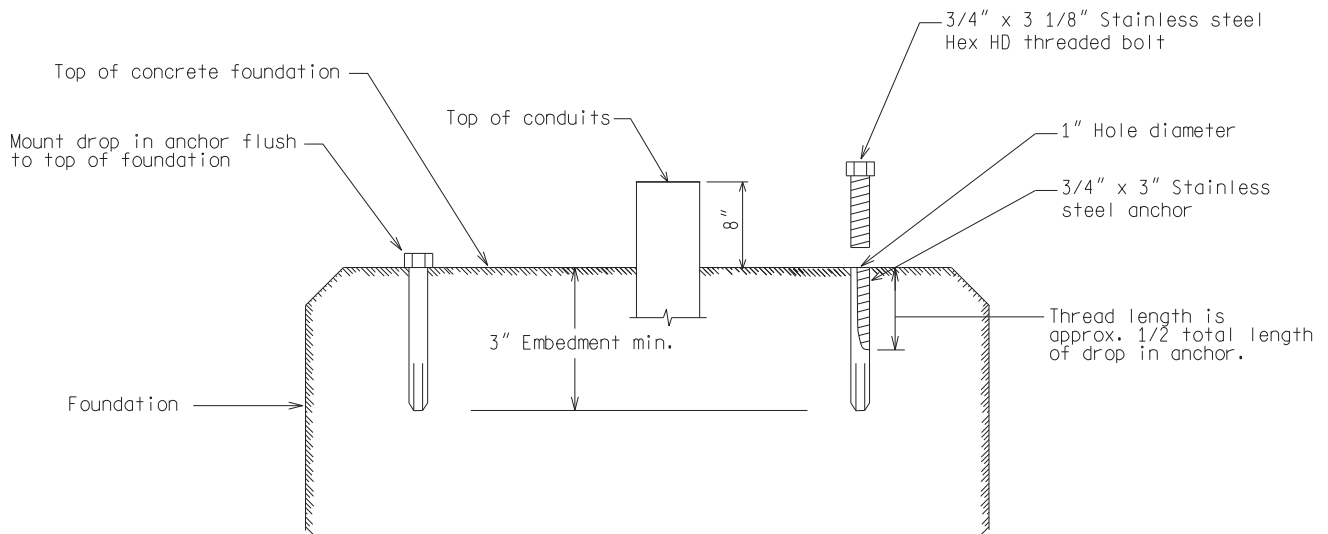

Notes:

1. Use AISI 300 Series Stainless Steel for all bolts and anchors.
2. Use Drop In foundation bolts and anchors as directed by the Engineer.

ALTERNATIVE DETAIL "A": DROP IN FOUNDATION BOLTS & ANCHORS

NOT TO SCALE

MICHIGAN DEPARTMENT OF TRANSPORTATION BUREAU OF HIGHWAYS DELIVERY STANDARD PLAN	(SPECIAL DETAIL) FHWA APPROVAL DATE		SIG-110-A	SHEET 6 of 7
File: RefDoc/TR/Signals/Web/Sp Det/Fin/SIG110A.dgn	Rev. 02/16/17	PLAN DATE		

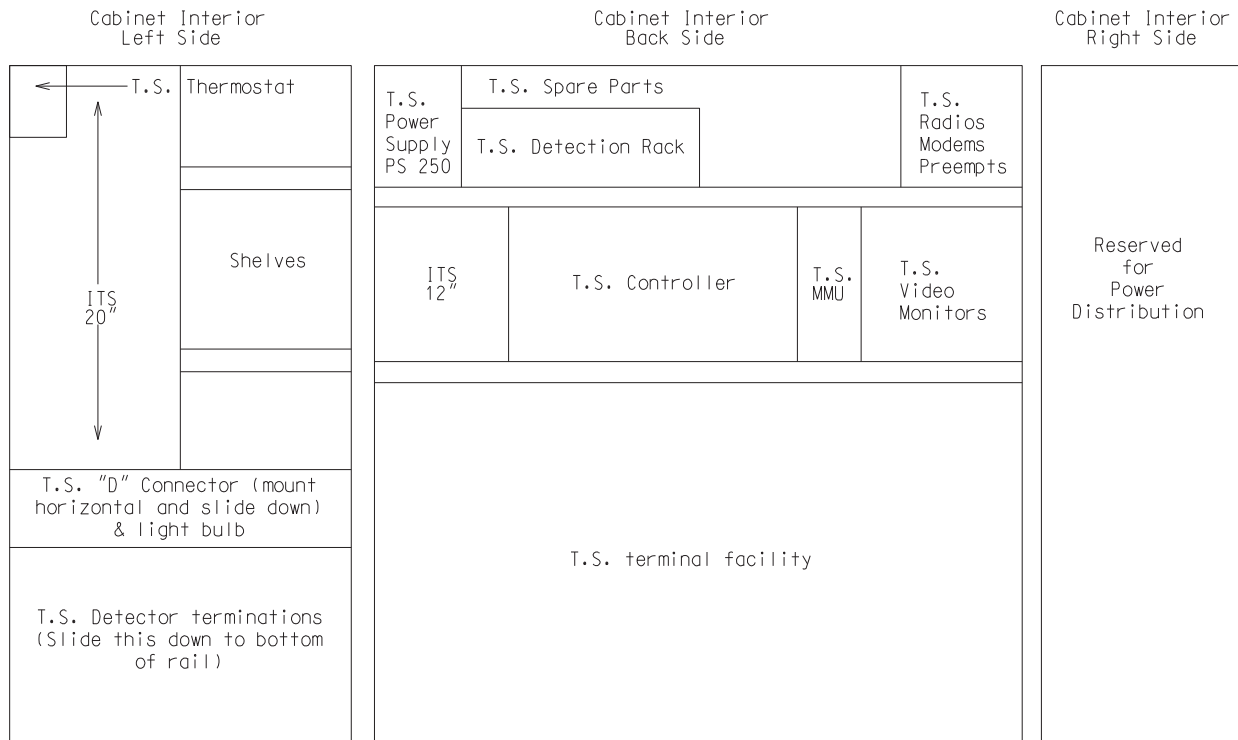

TRAFFIC SIGNAL NEMA 3R SIZE 6 CABINET REQUIREMENTS

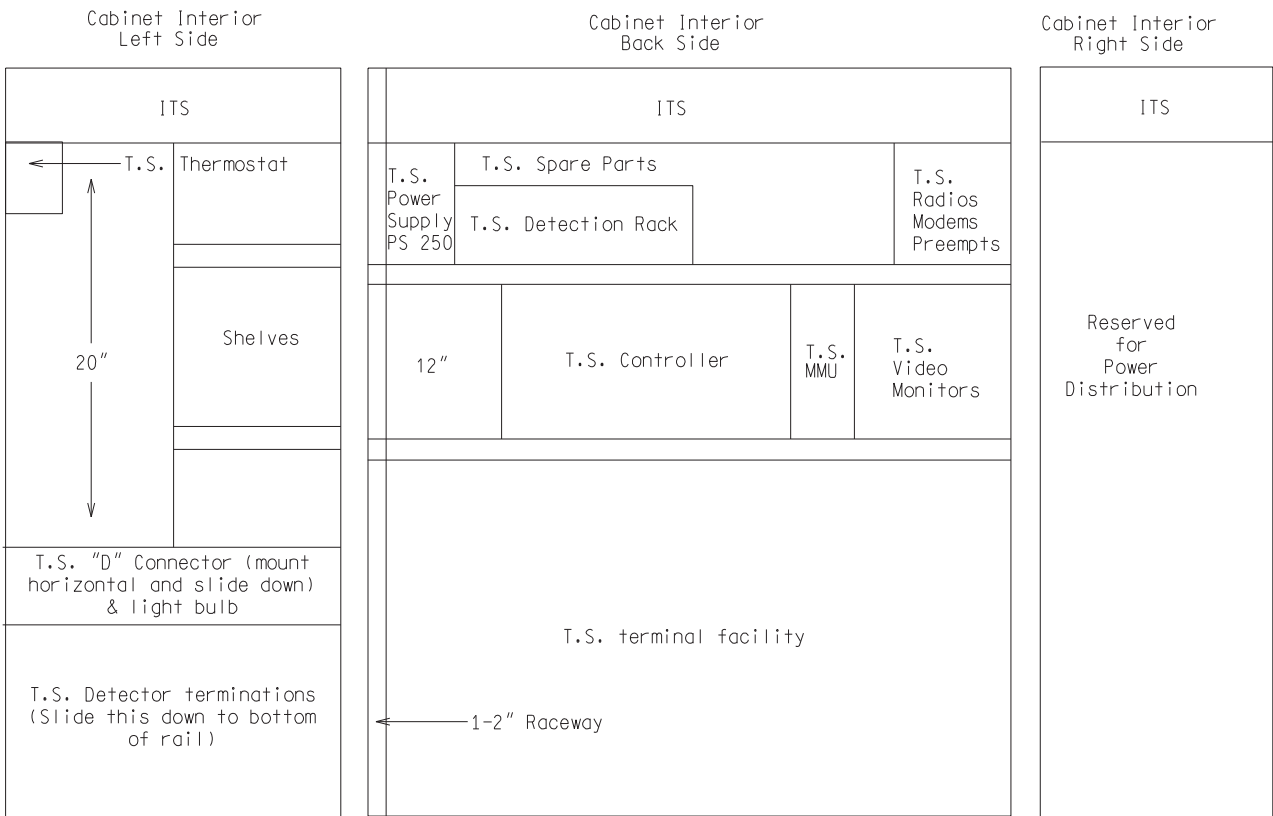

TRAFFIC SIGNAL NEMA 3R SIZE 6 STRETCH CABINET REQUIREMENTS

FOR ITS APPLICATIONS

NOT TO SCALE

MICHIGAN DEPARTMENT OF TRANSPORTATION
BUREAU OF HIGHWAYS DELIVERY STANDARD PLAN

(SPECIAL DETAIL)
FHWA APPROVAL DATE

PLAN DATE

SIG-110-A

SHEET
7 of 7

(* NOTE: STAINLESS STEEL ANCHOR BOLTS OR STAINLESS STEEL DROP INS, TO BE USED ON EXISTING FOUNDATIONS WITH PROPER GRADE AND SIZE.

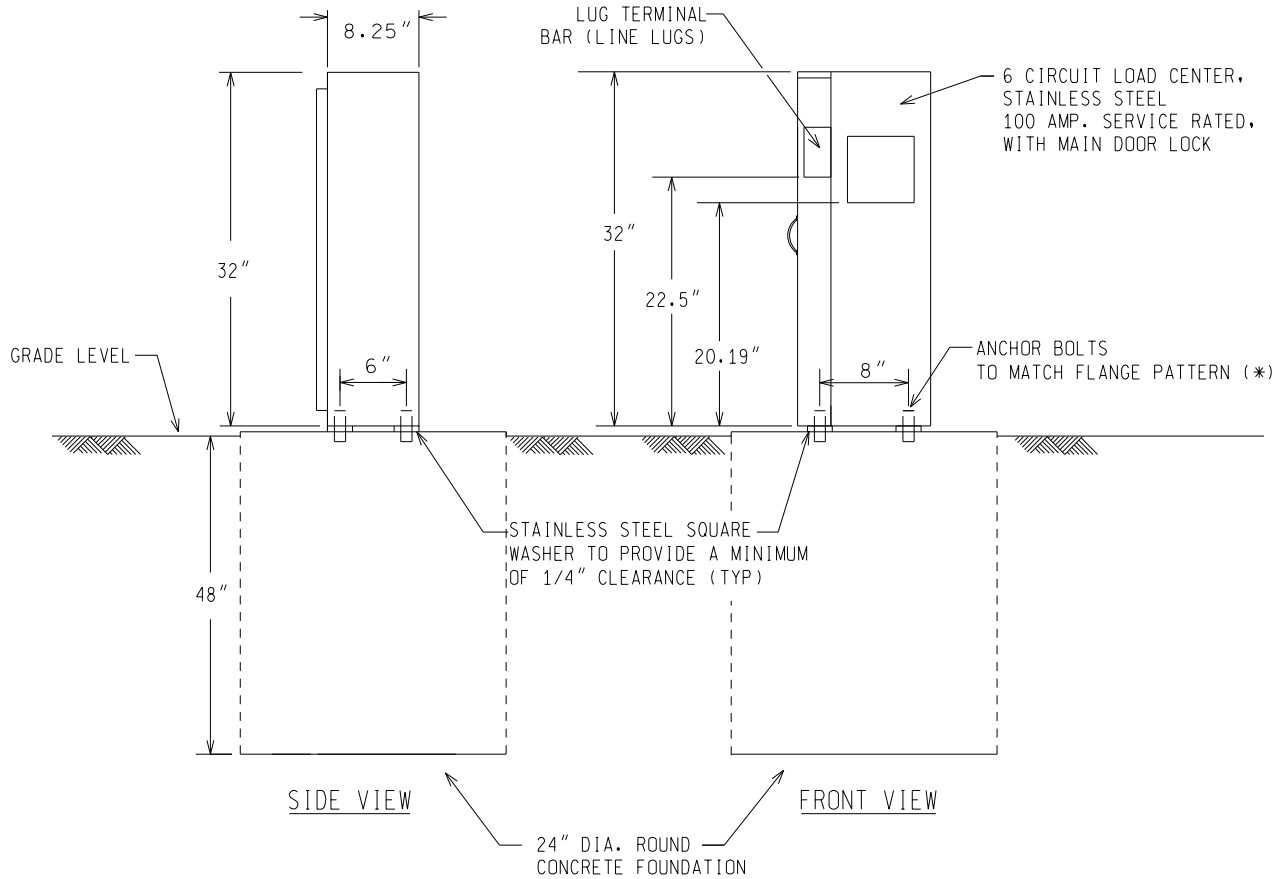

UNDERGROUND (UG) SERVICE PEDESTAL (METAL)
MOUNTED ON FOUNDATION

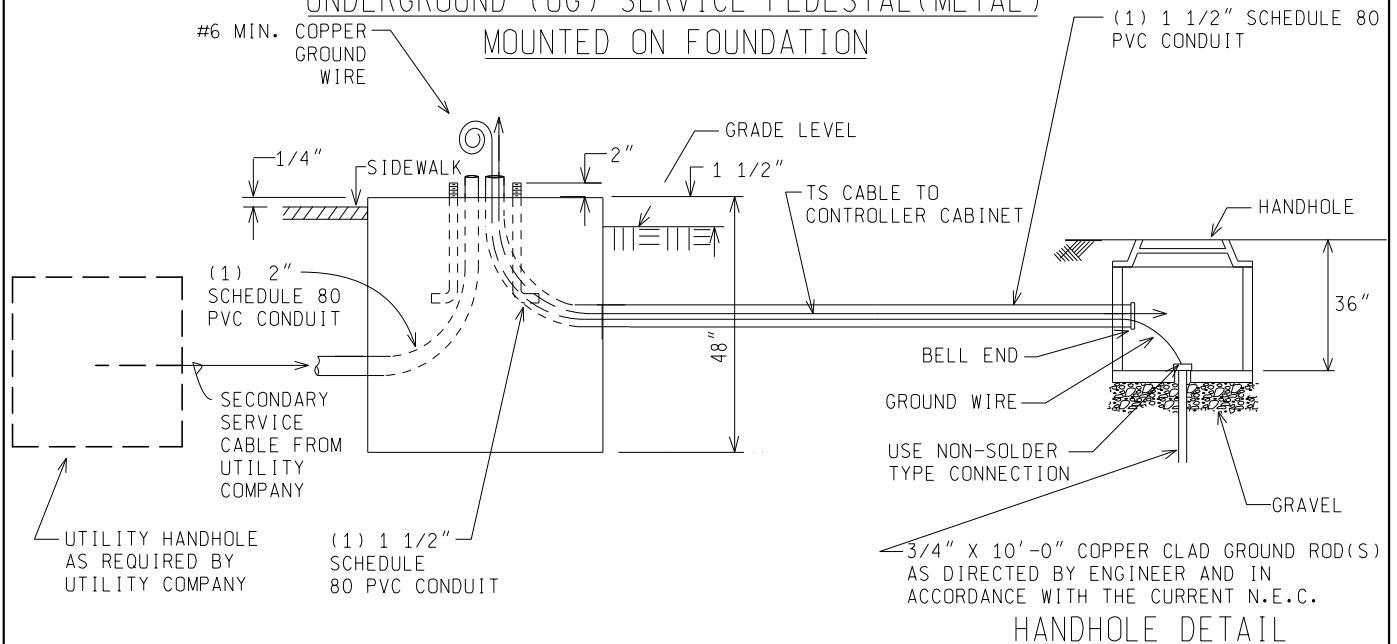

NOT TO SCALE

File: RefDoc/TR/Signals/Web/Sp Det/Fin/SIG210B.dgn Rev. 02/06/18



PREPARED BY
TRAFFIC AND SAFETY

DRAWN BY: DSP

CHECKED BY:

ENGINEER OF DELIVERY

ENGINEER OF DEVELOPMENT

(SPECIAL DETAIL)

FHWA APPROVAL DATE

MICHIGAN DEPARTMENT OF TRANSPORTATION
BUREAU OF HIGHWAYS DELIVERY STANDARD PLAN FOR
UNDERGROUND SERVICE
METERED AND UNMETERED

PLAN DATE

SIG-210-B

SHEET
1 of 3

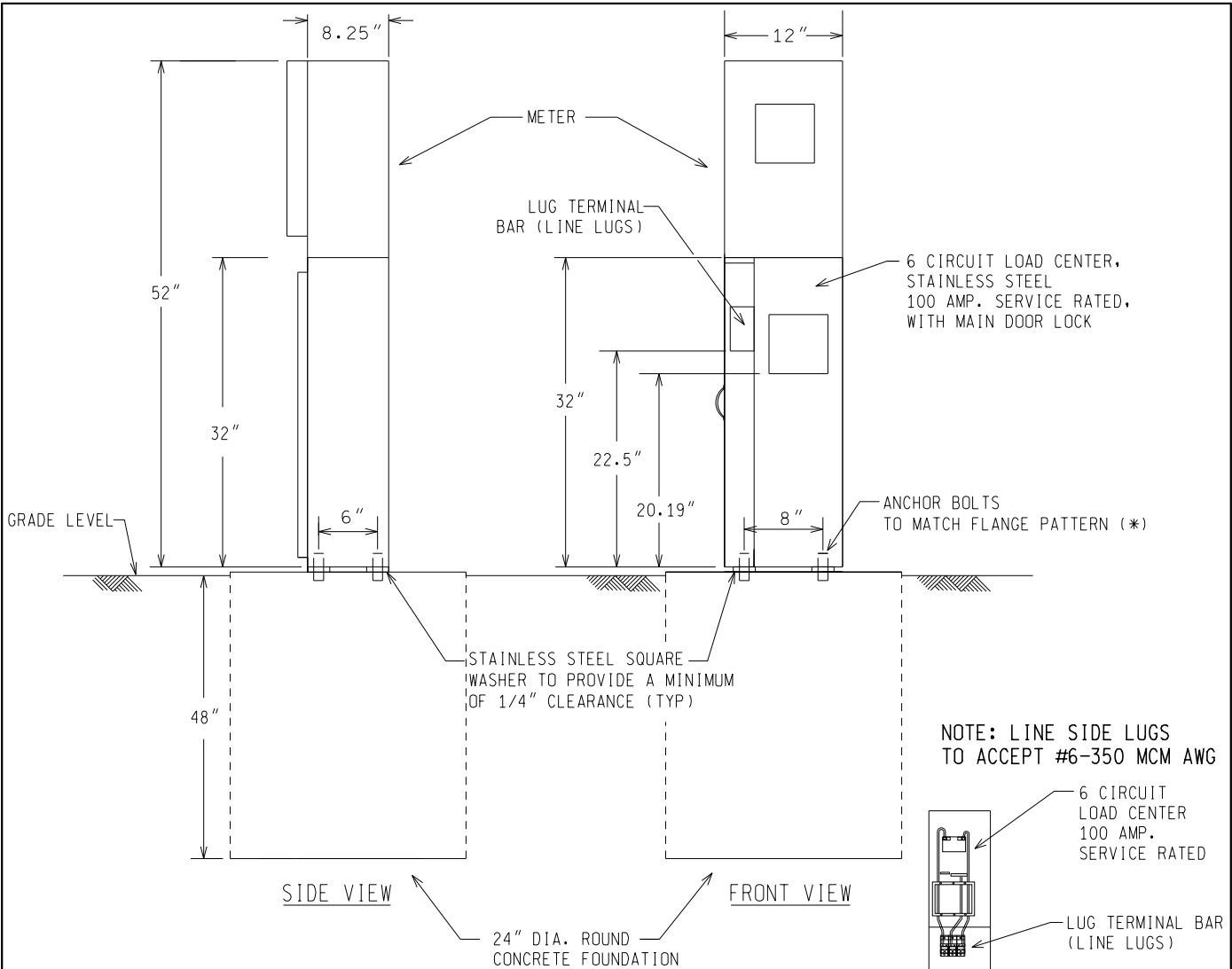

NOTE: LINE SIDE LUGS TO ACCEPT #6-350 MCM AWG

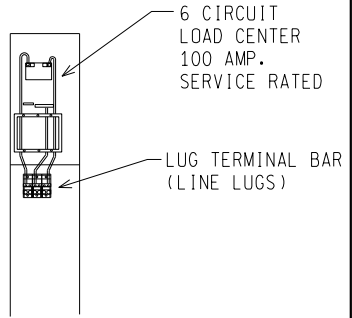

DETAIL WIRING DIAGRAM (UNMETERED)

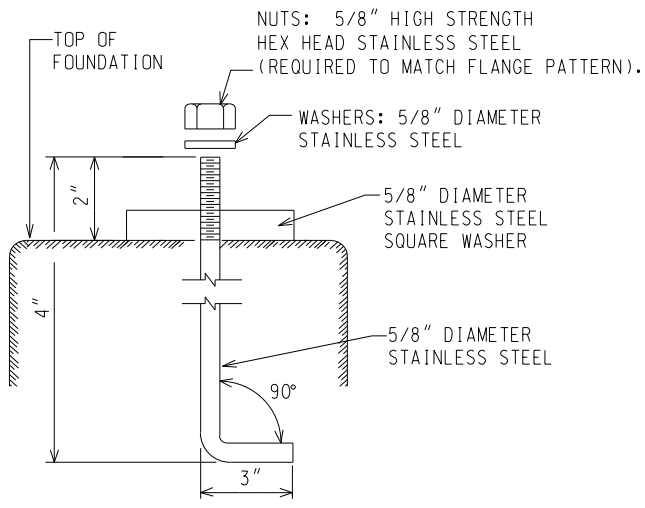

ANCHOR BOLT DETAIL

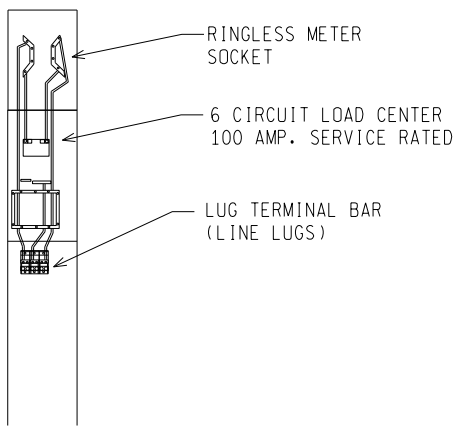

DETAIL WIRING DIAGRAM (METERED)

NOT TO SCALE

MICHIGAN DEPARTMENT OF TRANSPORTATION BUREAU OF HIGHWAYS DELIVERY STANDARD PLAN	(SPECIAL DETAIL) FHWA APPROVAL DATE	PLAN DATE	SIG-210-B	SHEET 2 of 3
--	--	-----------	-----------	-----------------

PREFERRED SITE
ORIENTATION PLAN

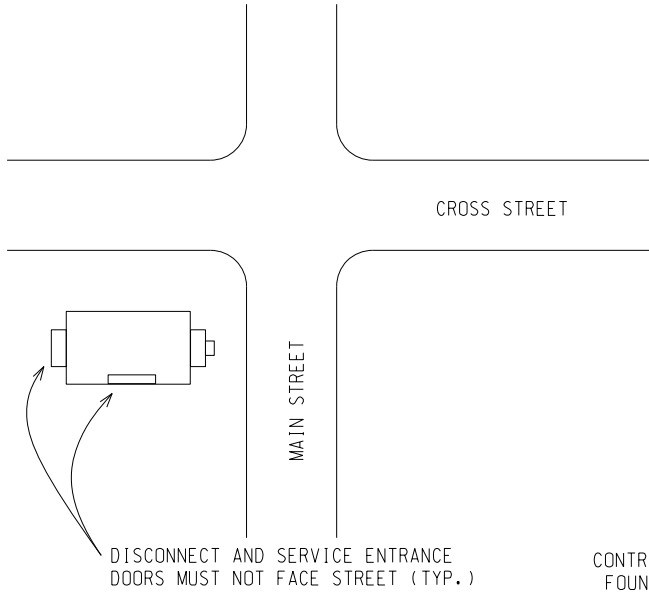

(PLACE PEDESTAL SO IT DOES NOT INTERFERE WITH FULL OPERATION OF CABINET DOOR)

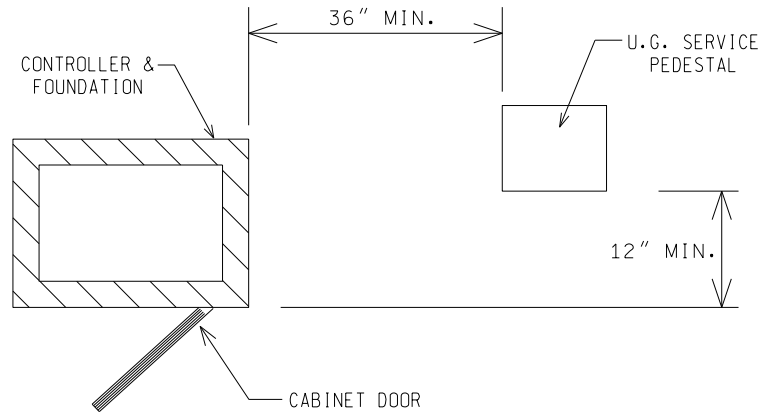

PREFERRED PEDESTAL & FOUNDATION
ORIENTATION PLAN

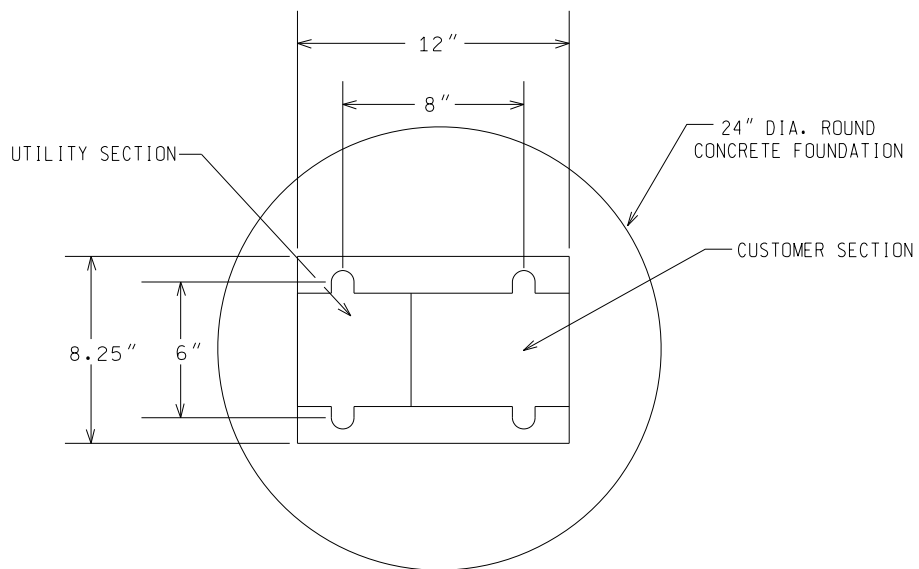

BOLT PATTERN LAYOUT

NOT TO SCALE

MICHIGAN DEPARTMENT OF TRANSPORTATION BUREAU OF HIGHWAYS DELIVERY STANDARD PLAN	(SPECIAL DETAIL) FHWA APPROVAL DATE	PLAN DATE	SIG-210-B	SHEET 3 of 3
File: RefDoc/TR/Signals/Web/Sp Det/Fin/SIG210B.dgn	Rev. 02/06/18			

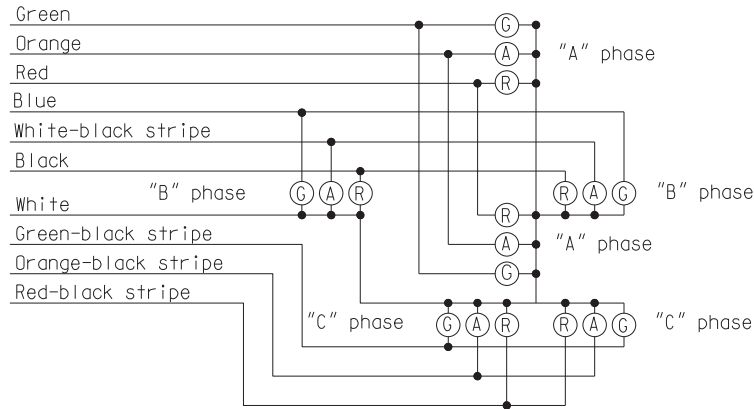

COLOR CODE FOR WIRING CONNECTING TRAFFIC SIGNAL LAMPS

NOTE: No splices allowed between traffic signal head and controller.

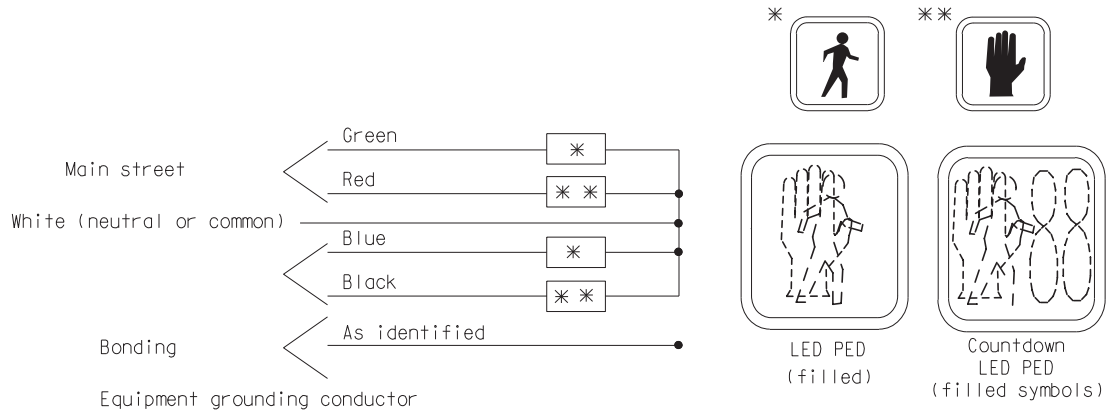

COLOR CODE FOR WIRING CONNECTING PEDESTRIAN SIGNAL LAMPS
(WALKING PERSON - HAND SYMBOL)

NOT TO SCALE

File: RefDoc/TR/Signals/Web/Sp Det/Fin/SIG230A.dgn Rev: 02/16/17



PREPARED BY
TRAFFIC AND SAFETY

DRAWN BY: DJF

CHECKED BY:

ENGINEER OF DELIVERY

ENGINEER OF DEVELOPMENT

(SPECIAL DETAIL)

FHWA APPROVAL DATE

MICHIGAN DEPARTMENT OF TRANSPORTATION
BUREAU OF HIGHWAYS DELIVERY STANDARD PLAN FOR

**COLOR CODE WIRING/
EQUIPMENT GROUNDING**

PLAN DATE

SIG-230-A

SHEET
1 of 6

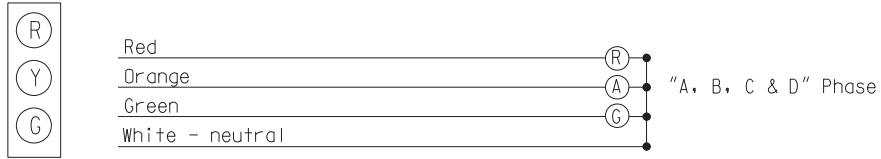

STANDARD - 3 COLOR SIGNAL DISPLAY

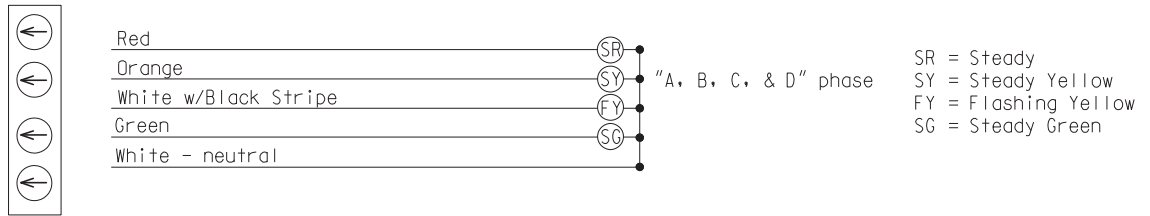

FLASHING YELLOW ARROW (FYA) - 4 COLOR SIGNAL DISPLAY

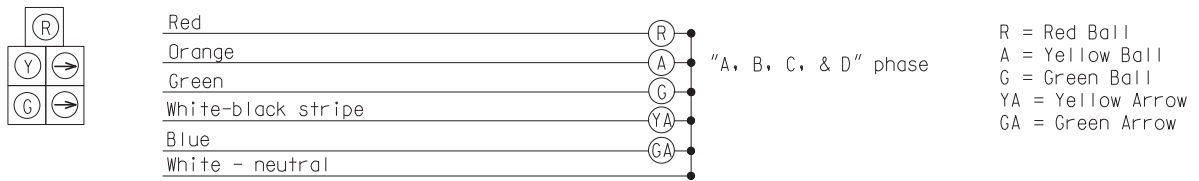

DOG HOUSE W/RIGHT TURNS - 5 COLOR SIGNAL DISPLAY

COLOR CODE FOR WIRING CONNECTING TRAFFIC SIGNAL LAMPS

NOT TO SCALE

MICHIGAN DEPARTMENT OF TRANSPORTATION
BUREAU OF HIGHWAYS DELIVERY STANDARD PLAN

(SPECIAL DETAIL)
FHWA APPROVAL DATE

PLAN DATE

SIG-230-A

SHEET
2 of 6

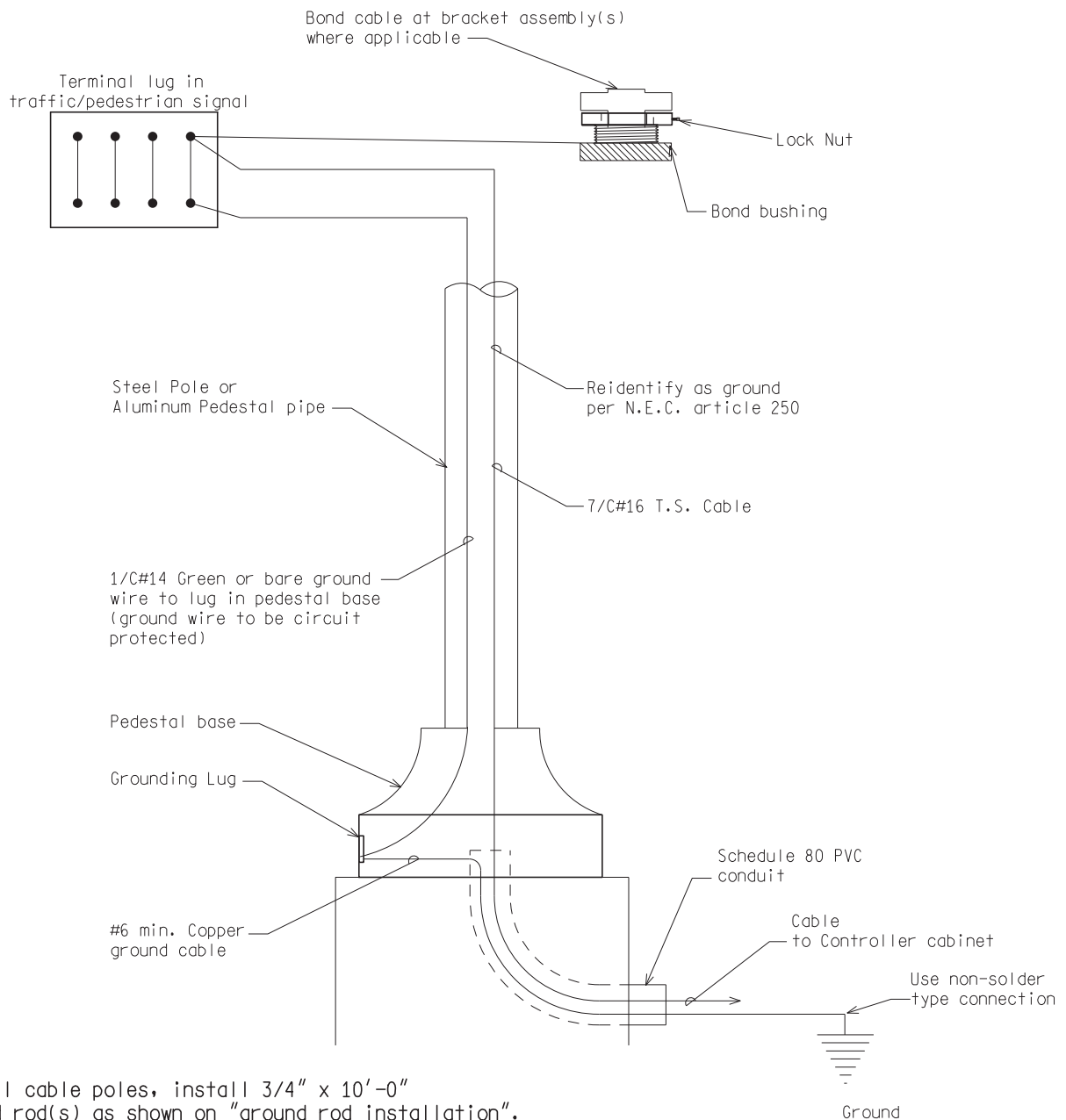

NOTE:
 For all cable poles, install 3/4" x 10'-0" ground rod(s) as shown on "ground rod installation".
 Connect ground rod(s) with #6 min. copper wire to messenger wire with non-solder type connection.

STEEL POLE/PEDESTAL GROUNDING DETAIL

NOT TO SCALE

MICHIGAN DEPARTMENT OF TRANSPORTATION
 BUREAU OF HIGHWAYS DELIVERY STANDARD PLAN

(SPECIAL DETAIL)
 FHWA APPROVAL DATE

PLAN DATE

SIG-230-A

SHEET
 3 of 6

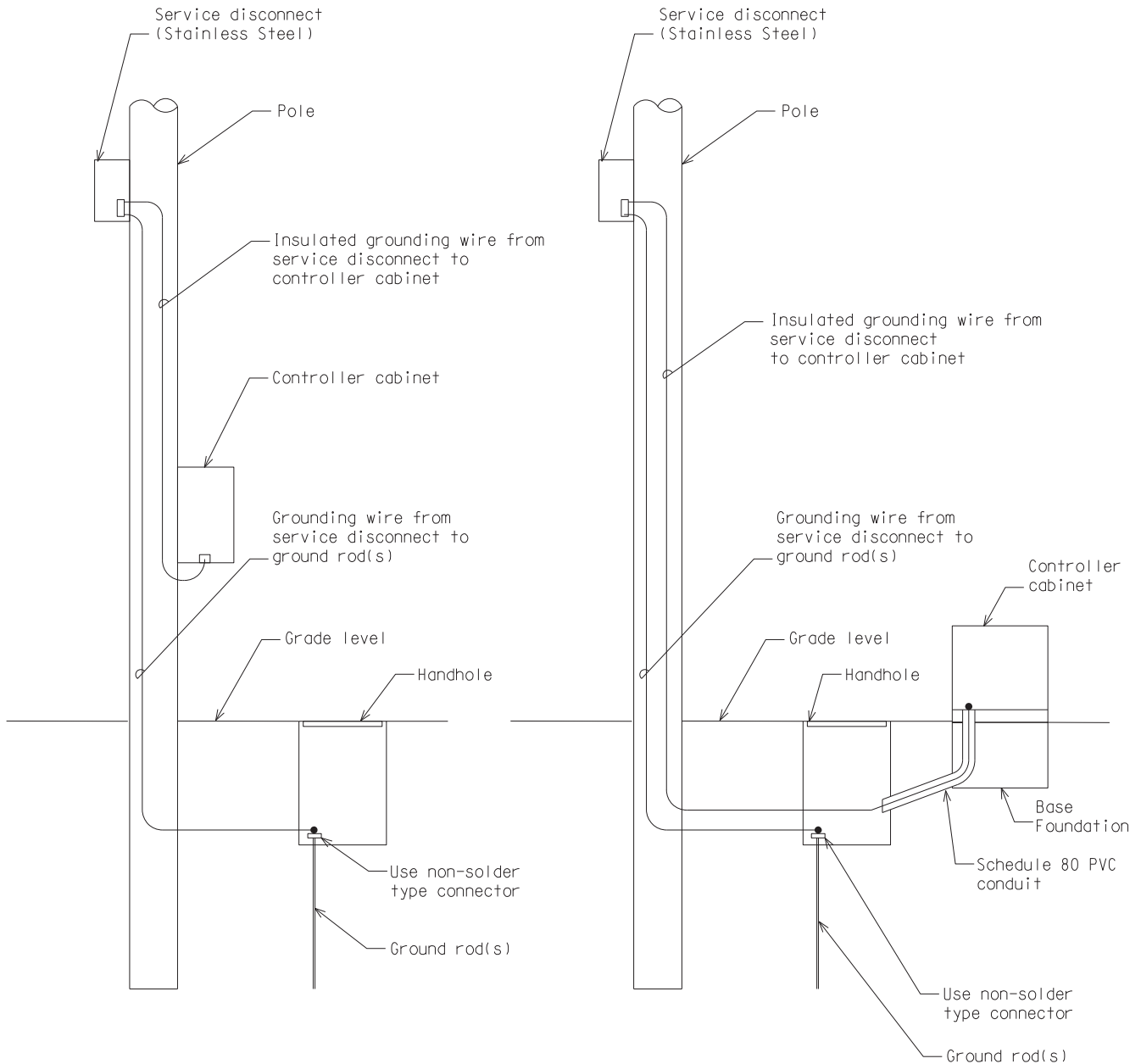

GROUNDING

Install 3/4 " x 10'-0" copper clad ground rod(s) as required to provide less than 10 OHM resistance to ground.

Grounding wire #6 AWG min. bare copper grounding wire shall be installed to meet N.E.C. and utility company specs.

Ground wire from disconnect to ground rod to be in moulding (wood pole or post) or inside the pole (steel). Ground wire from disconnect to controller cabinet to be in conduit (wood pole, wood post, and steel pole).

CONTROLLER CABINET GROUNDING DETAIL

NOT TO SCALE

MICHIGAN DEPARTMENT OF TRANSPORTATION BUREAU OF HIGHWAYS DELIVERY STANDARD PLAN	(SPECIAL DETAIL) FHWA APPROVAL DATE		SIG-230-A	SHEET 4 of 6
File: RefDoc/TR/Signals/Web/Sp Det/Fin/SIG230A.dgn Rev. 02/16/17		PLAN DATE		

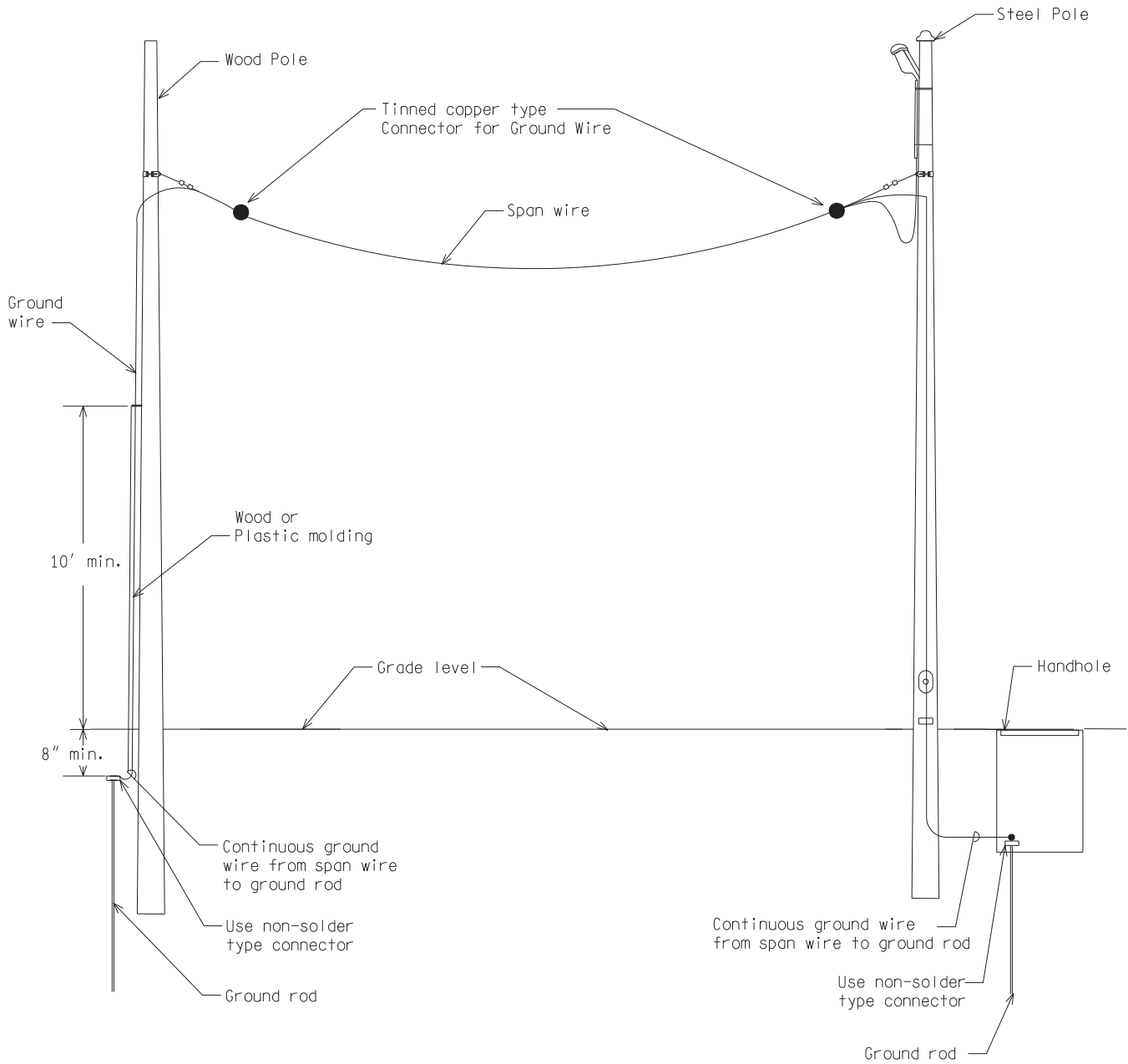

SPAN WIRE GROUNDING DETAIL

NOT TO SCALE

MICHIGAN DEPARTMENT OF TRANSPORTATION
BUREAU OF HIGHWAYS DELIVERY STANDARD PLAN

(SPECIAL DETAIL)
FHWA APPROVAL DATE

PLAN DATE

SIG-230-A

SHEET
5 of 6

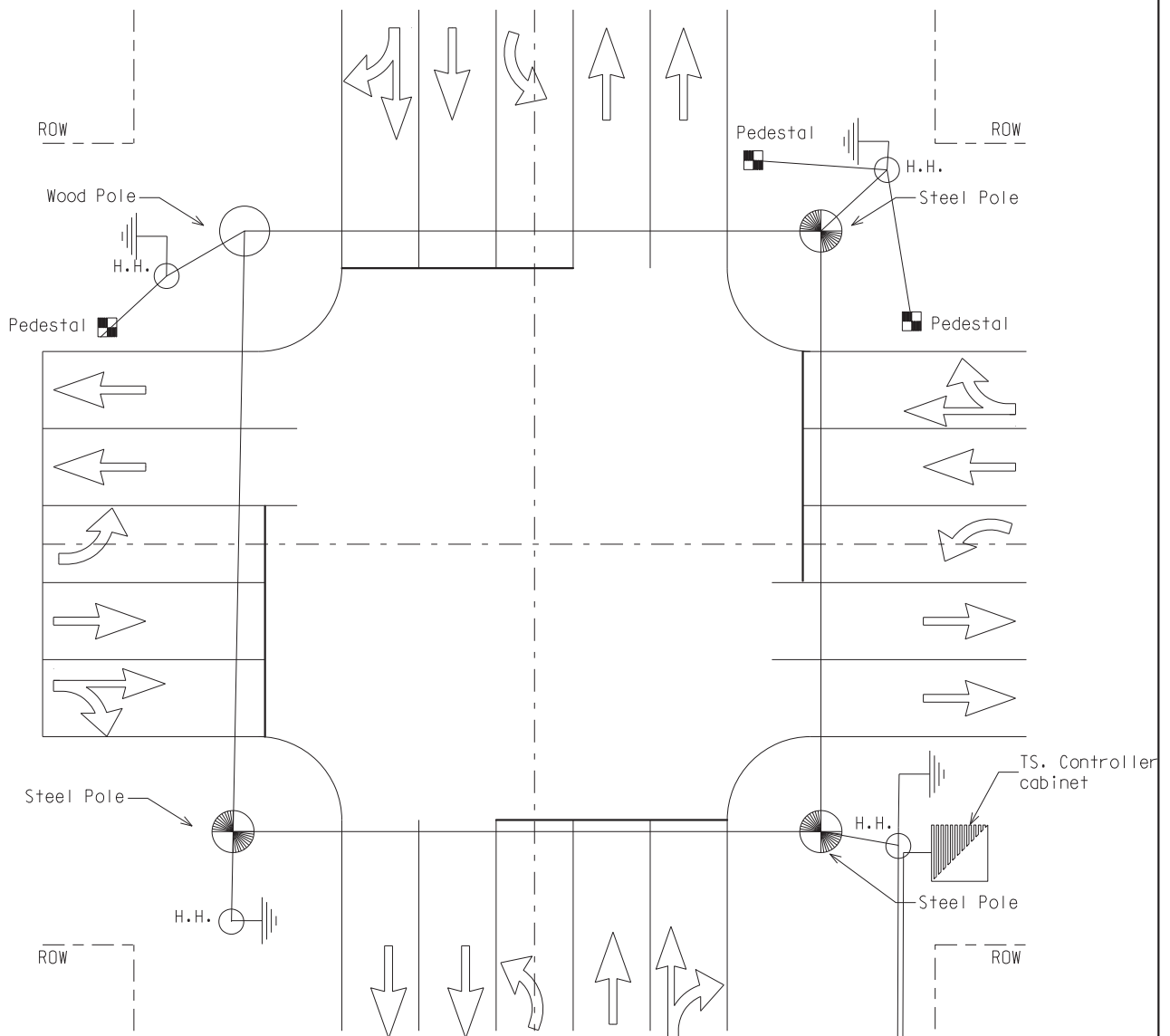

- 1) All ground rods shall be 3/4" x 10' in length copperclad.
- 2) Ground rods shall be drive straight down, so that only the required portions of of the ground rod is exposed to attach the ground wires.
- 3) All ground rods shall be connected to each other or to a span wire with a single #6 AWG copper conductor.
- 4) Each ground wire attaching to a ground rod shall have its own approved acorn type connector.
- 5) Do not install any ground rods within 10' of any other ground rods from other grounding.
- 6) The grounding system shall measure 10 ohms or less.
- 7) A separate insulated green #6 AWG copper ground is required from the service disconnect (safety switch) to the ground bussbar in the controller cabinet.
- 8) Ground rod for each steel pole, wood pole, pedestal and/or traffic signal controller cabinet shall be located in the adjacent handhole as indicated on the plans or as directed by the Engineer.
- 9) All metal bases must be connected to a ground rod with a #6 ground wire.

SYSTEM GROUNDING DETAIL

NOT TO SCALE

MICHIGAN DEPARTMENT OF TRANSPORTATION
BUREAU OF HIGHWAYS DELIVERY STANDARD PLAN

(SPECIAL DETAIL)
FHWA APPROVAL DATE

PLAN DATE

SIG-230-A

SHEET
6 of 6

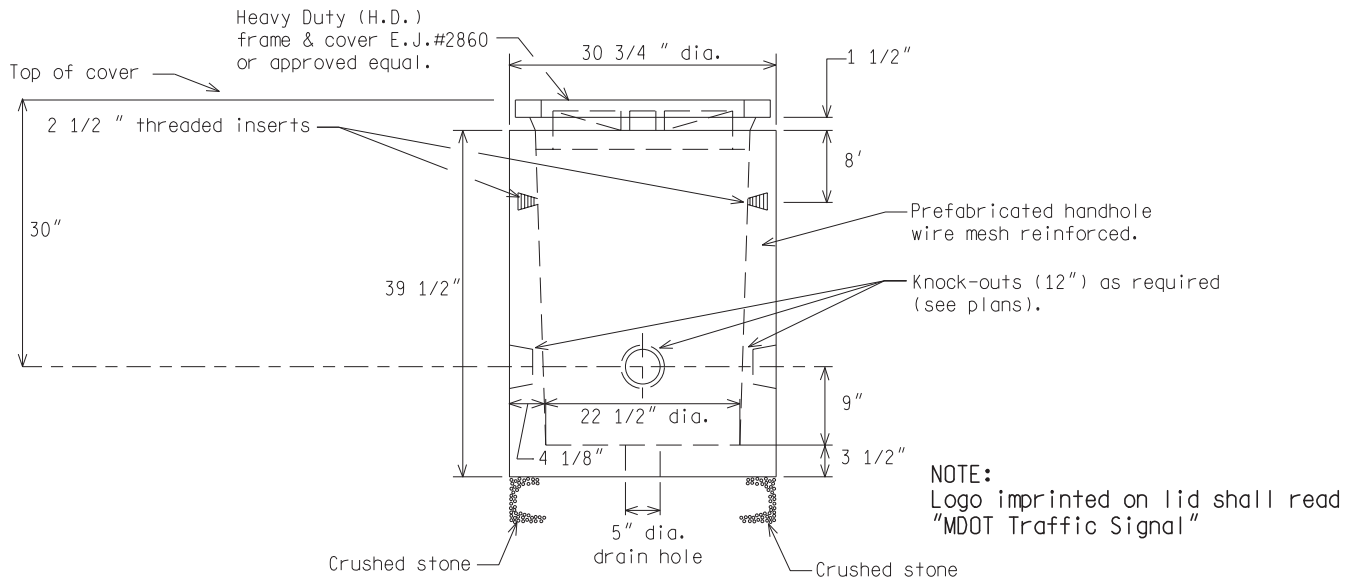

2' PRECAST ROUND HANDHOLE WITH FLOOR

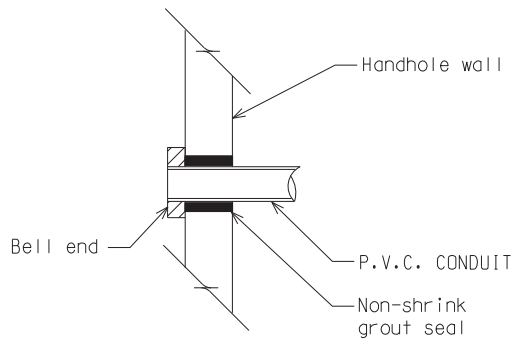

TYPICAL CONDUIT ENTRANCE AT HANDHOLE

NOT TO SCALE

File: RefDoc/TR/Signals/Web/Sp Det/Fin/SIG240A.dgn Rev: 02/16/17



PREPARED BY
TRAFFIC AND SAFETY

DRAWN BY: DJF

CHECKED BY:

ENGINEER OF DELIVERY

ENGINEER OF DEVELOPMENT

(SPECIAL DETAIL)

FHWA APPROVAL DATE

MICHIGAN DEPARTMENT OF TRANSPORTATION
BUREAU OF HIGHWAYS DELIVERY STANDARD PLAN FOR

HANDHOLE- PRECAST,
POLYMER CONCRETE

PLAN DATE

SIG-240-A

SHEET
1 of 6

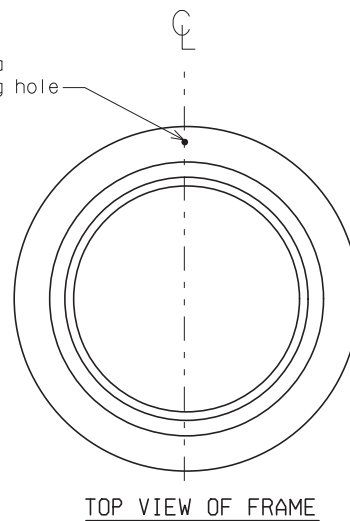
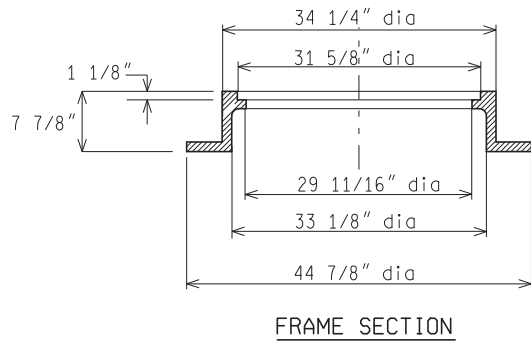
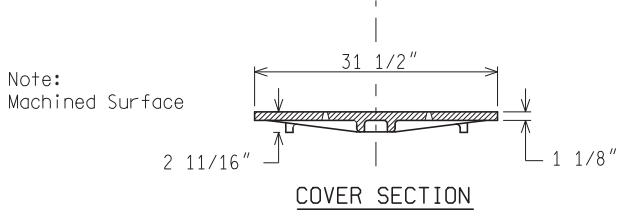
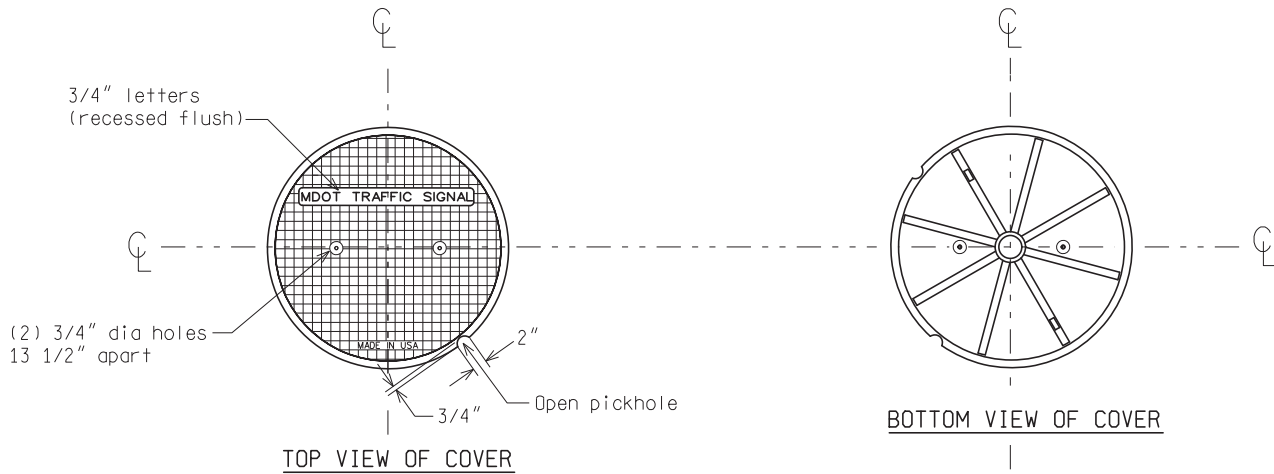

The H. D. frame and cover shall be manufactured by East Jordan Iron Works, Model 1220 or approved equal.

FRAME AND COVER

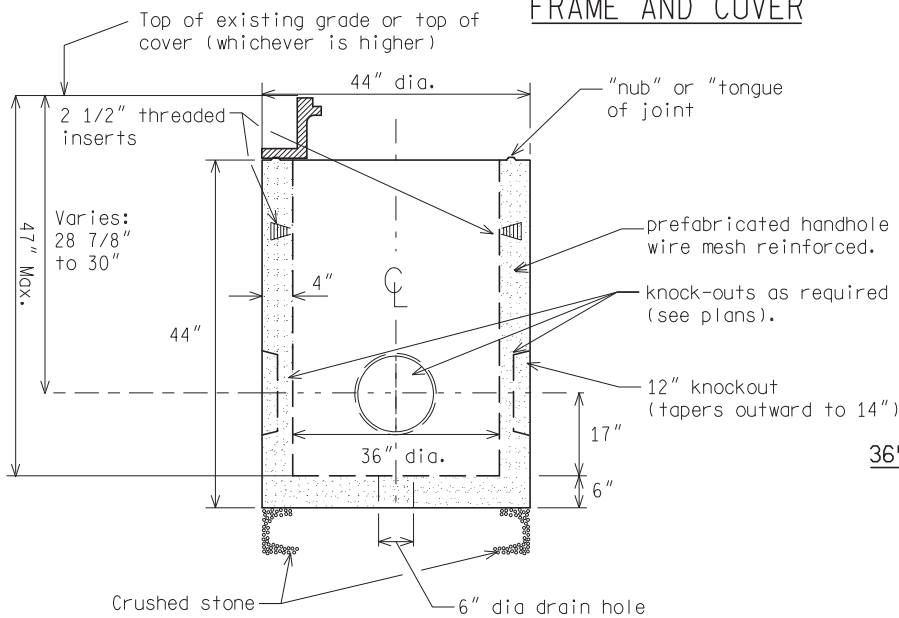

NOTE:
Logo imprint may read "Traffic Signal" for non MDOT Installation

36" PRECAST ROUND HANDHOLE SECTION DETAIL

3' DIAMETER ROUND PRECAST CONCRETE HANDHOLE

NOT TO SCALE

MICHIGAN DEPARTMENT OF TRANSPORTATION
BUREAU OF HIGHWAYS DELIVERY STANDARD PLAN

(SPECIAL DETAIL)
FHWA APPROVAL DATE

File: RefDoc/TR/Signals/Web/Sp Det/Fin/SIG240A.dgn Rev. 02/16/17

PLAN DATE

SIG-240-A

SHEET
2 of 6

NOTE:
Logo imprint may read "Traffic Signal"
for non MDOT installations

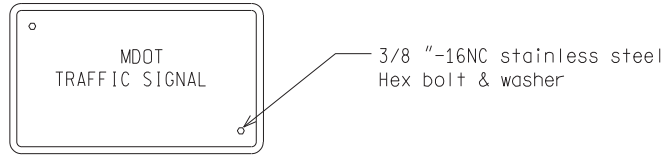

COVER
N.T.S.

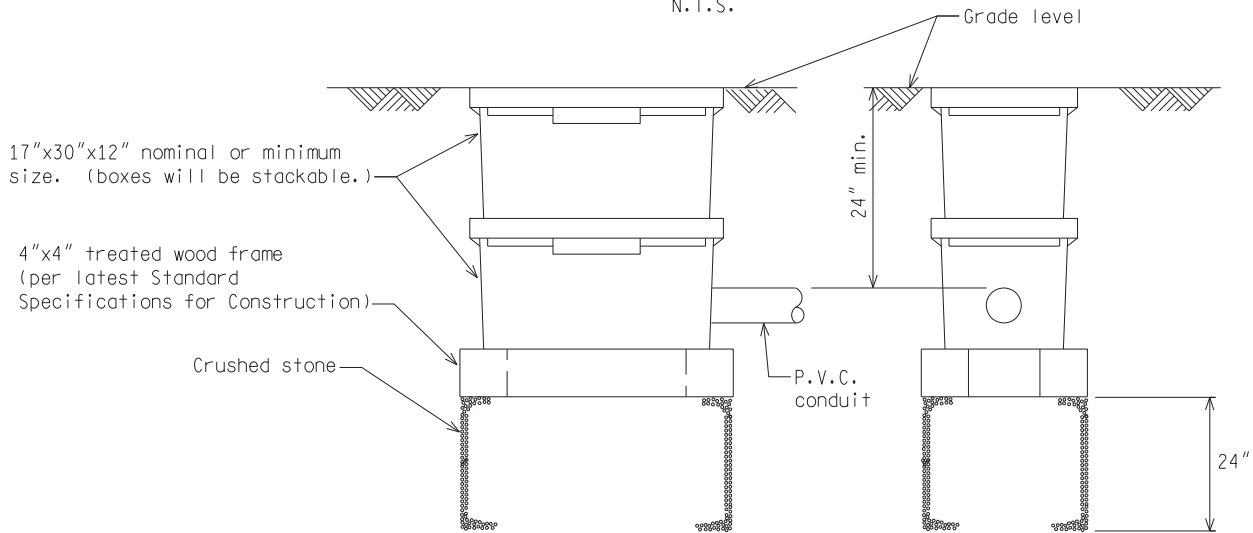

POLYMER CONCRETE HANDHOLE

NOTES PERTAIN TO PRECAST OR BRICK:

- 1) The material and workmanship shall be in accordance with the current M.D.O.T. Standard Specifications for Construction.
- 2) All concrete masonry shall be grade 30M.
- 3) The inner surface of the handhole shall be smooth.
- 4) Heavy Duty covers shall be castings which meet the requirements of the current specifications for gray iron castings ASTM designation A48 and shall have a minimum strength as provided for Class No. 30 gray iron castings.
- 5) All castings shall be cleaned by sand blasting.
- 6) The seating face of the cover and the seat for the same on the frame if required, shall be ground or machined so that the cover shall have an even bearing on its seat to prevent rocking or tilting.
- 7) The castings shall be free of pouring faults, blow holes, cracks, and other imperfections. They shall be sound, true to form and thickness, clean and neatly finished and shall be coated with tar pitch varnish.
- 8) Light Duty cover shall be bolted to frame with not less than 2 countersunk Hex head bronze bolts.
- 9) The Heavy Duty cover & frame shall be East Jordan Iron Works #8206 Neenah Foundry, #R-6662-HP for square cover or East Jordan Iron Works #2860 Type "A", Neenah Foundry #R-6052 D for circular cover or an approved equal.
- 10) Handhole shall be equipped with cable rack and hooks to train cable.

NOT TO SCALE

MICHIGAN DEPARTMENT OF TRANSPORTATION BUREAU OF HIGHWAYS DELIVERY STANDARD PLAN	(SPECIAL DETAIL) FHWA APPROVAL DATE		SIG-240-A	SHEET 3 of 6
File: RefDoc/TR/Signals/Web/Sp Det/Fin/SIG240A.dgn Rev. 02/16/17		PLAN DATE		

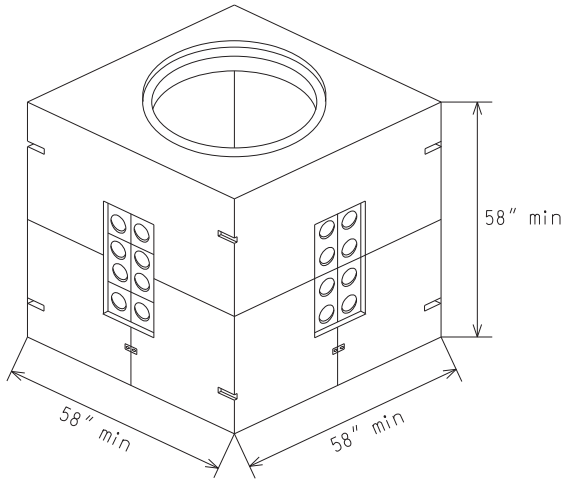

NOTE:
Galvanized step is standard with
grade ring ASTM C478.

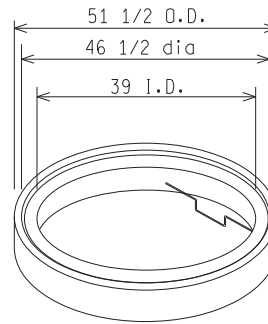

Dimensions	
A	Min Wt. (lbs)
6	440
9	650
12	860

	Length	Width	Height
Inside	48	48	48
Outside	58	58	58
Recommended Hole size	82	82	--

GRADE RING WITH 39" I.D. &
46 1/2" RECESS

	Min Thickness	Min Weight lbs
Wall	5	Top 3300
Roof	5	Bottom 3850
Floor	5	Total 7150

4' x 4' x 4' PRECAST CONCRETE HANDHOLE

NOT TO SCALE

MICHIGAN DEPARTMENT OF TRANSPORTATION
BUREAU OF HIGHWAYS DELIVERY STANDARD PLAN

(SPECIAL DETAIL)
FHWA APPROVAL DATE

File: RefDoc/TR/Signals/Web/Sp Det/Fin/SIG240A.dgn Rev. 02/16/17

PLAN DATE

SIG-240-A

SHEET
4 of 6

NOTE:
 Logo imprint it on cover shall
 read "MDOT Traffic Signal" for
 MDOT installations

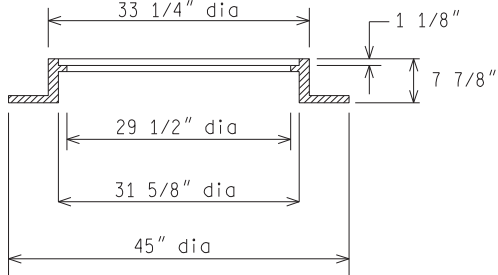
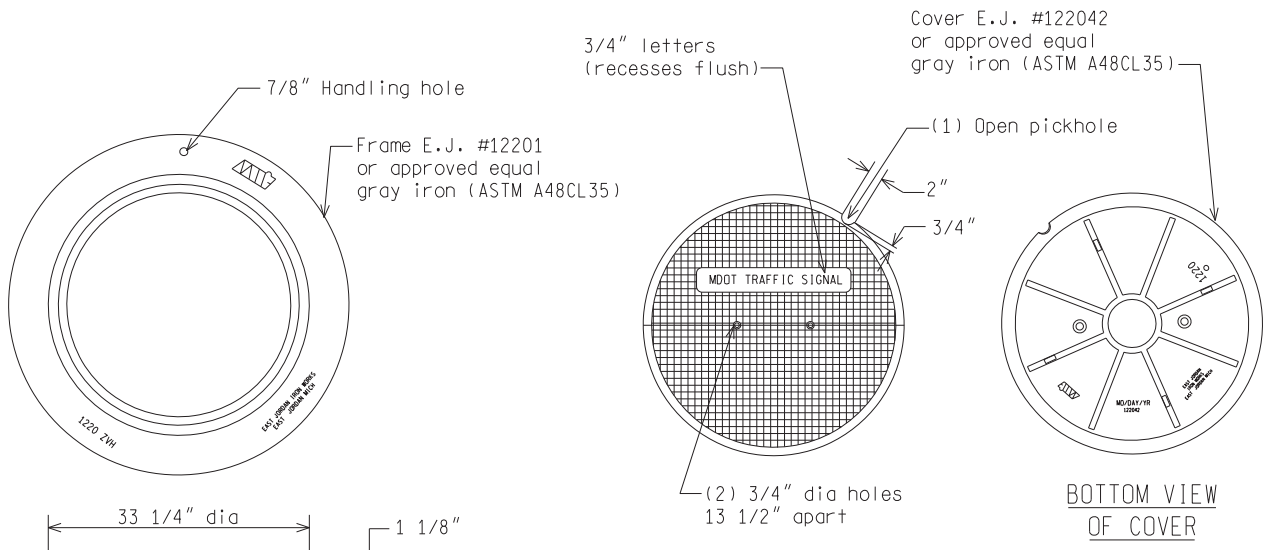

FRAME SECTION

MANHOLE FRAME
(HEAVY DUTY)

Estimated weight 410 lbs

NOTE:
 Machined surface

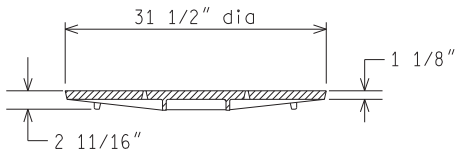

COVER SECTION

MANHOLE COVER
(HEAVY DUTY)

Estimated weight 245 lbs

NOTE:
 Machined surface

4' x 4' x 4' PRECAST CONCRETE HANDHOLE

NOT TO SCALE

MICHIGAN DEPARTMENT OF TRANSPORTATION
 BUREAU OF HIGHWAYS DELIVERY STANDARD PLAN

(SPECIAL DETAIL)
 FHWA APPROVAL DATE

File: RefDoc/TR/Signals/Web/Sp Det/Fin/SIG240A.dgn Rev. 02/16/17

PLAN DATE

SIG-240-A

SHEET
 5 of 6

Concrete: 4500 p.s.i. @ 28 days
 Reinforcement: Grade 60 rebar
 All bars are #4

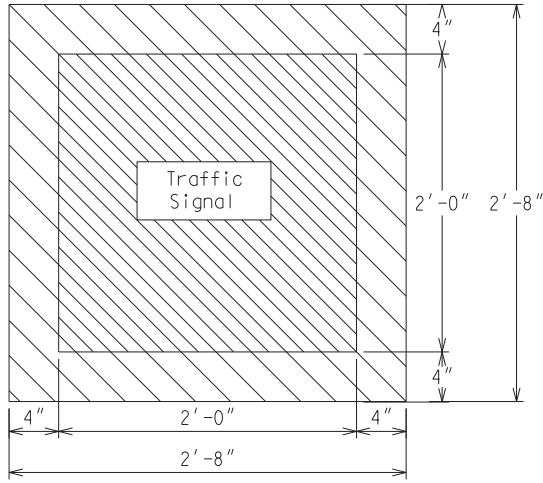

PLAN VIEW

With out frame & cover

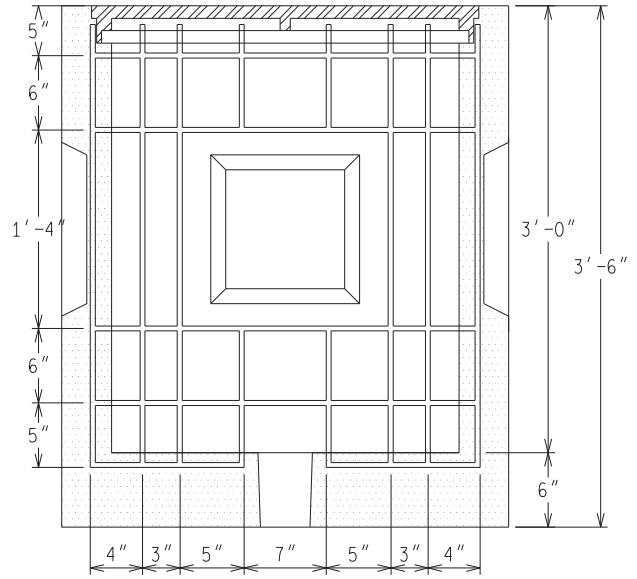

SECTION VIEW

Typ. reinforcement all walls

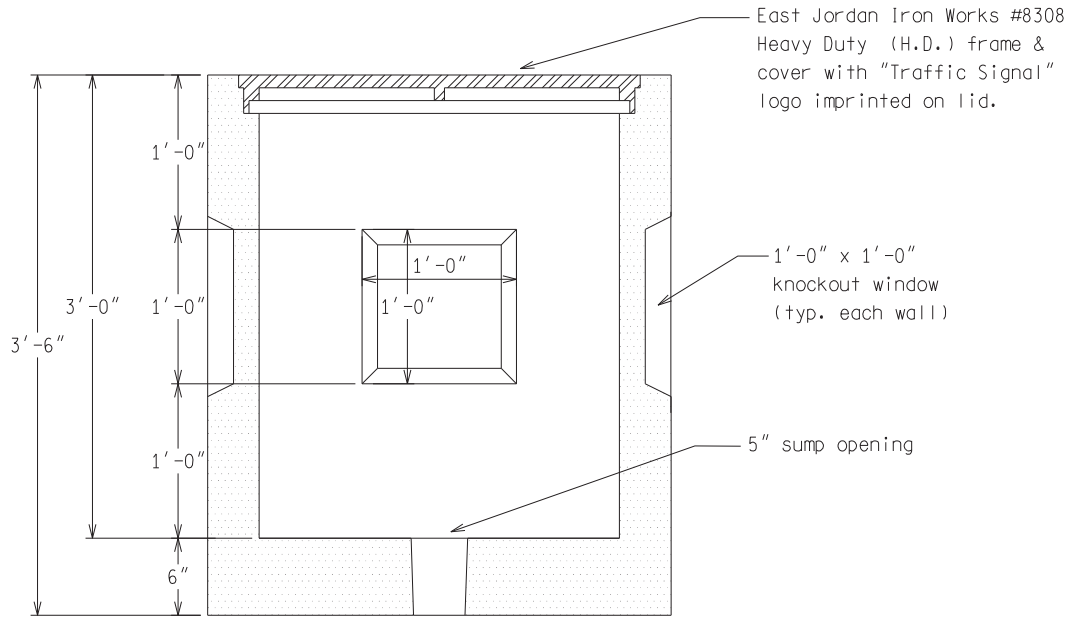

SECTION VIEW

2' x 2' SQUARE x 3' HANDHOLE

For use on Oakland County roads only.

NOT TO SCALE

MICHIGAN DEPARTMENT OF TRANSPORTATION
 BUREAU OF HIGHWAYS DELIVERY STANDARD PLAN

(SPECIAL DETAIL)
 FHWA APPROVAL DATE

PLAN DATE

SIG-240-A

SHEET
 6 of 6

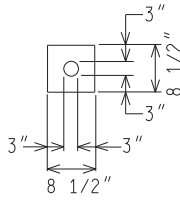

1 2" CONDUIT

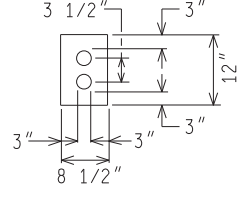

2 2" CONDUIT

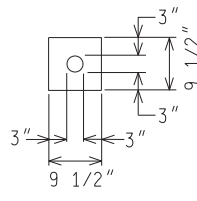

ONE
2 1/2" CONDUIT

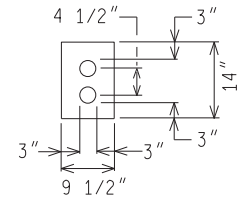

TWO
2 1/2" CONDUIT

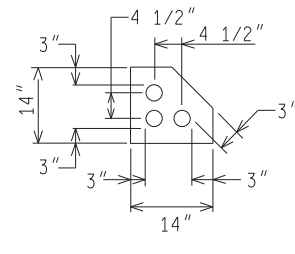

THREE
2 1/2" CONDUIT

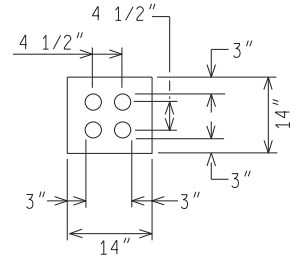

FOUR
2 1/2" CONDUIT

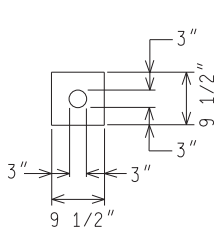

1 3" CONDUIT

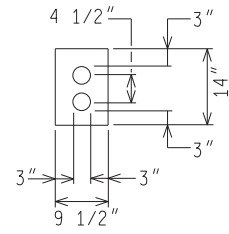

2 3" CONDUIT

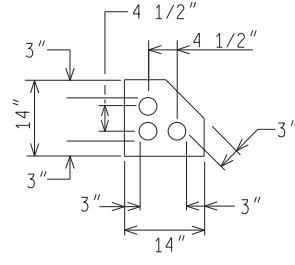

3 3" CONDUIT

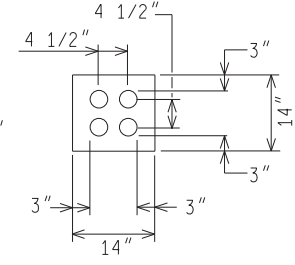

4 3" CONDUIT

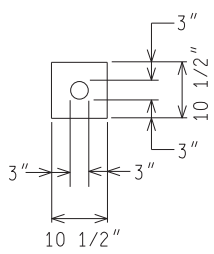

1 4" CONDUIT

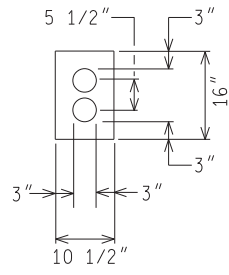

2 4" CONDUIT

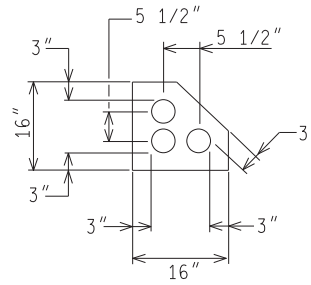

3 4" CONDUIT

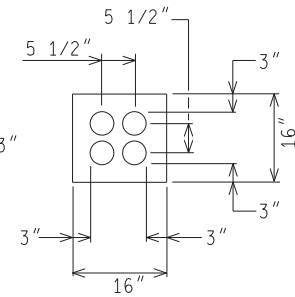

4 4" CONDUIT

ENCASED CONDUIT SECTIONS

NOT TO SCALE

MICHIGAN DEPARTMENT OF TRANSPORTATION
BUREAU OF HIGHWAYS DELIVERY STANDARD PLAN

(SPECIAL DETAIL)
FHWA APPROVAL DATE

PLAN DATE

SIG-250-A

SHEET
2 of 2

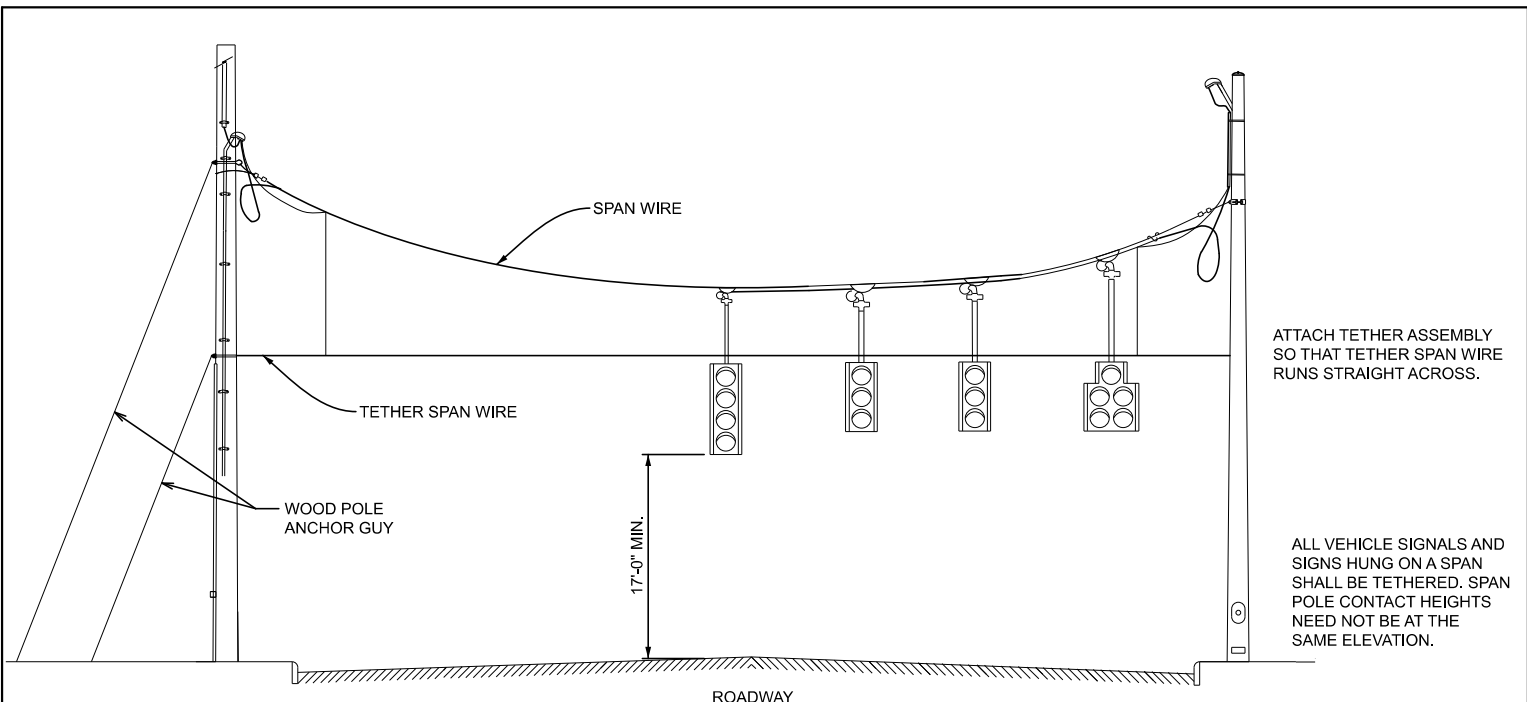

1 DETAIL - TOP TETHER

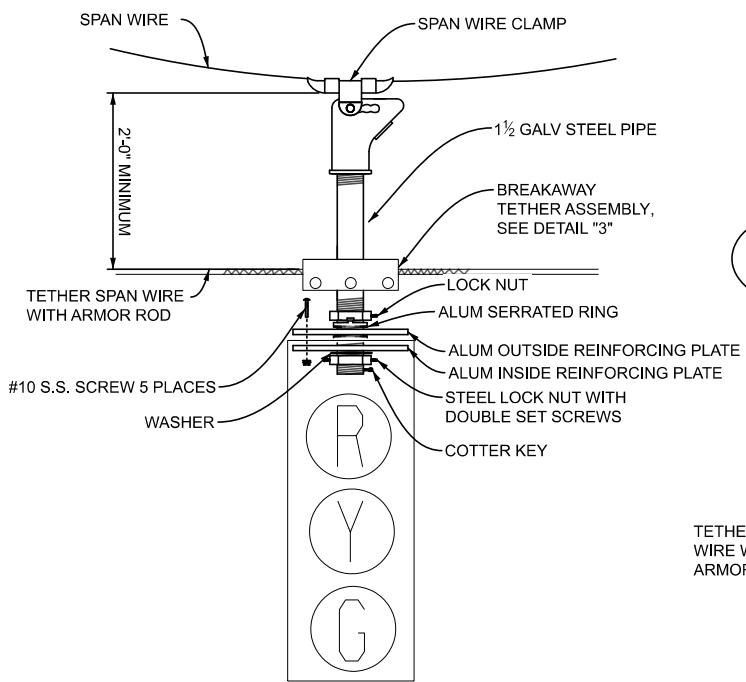

2 DETAIL - SPAN WIRE INSTALLATION

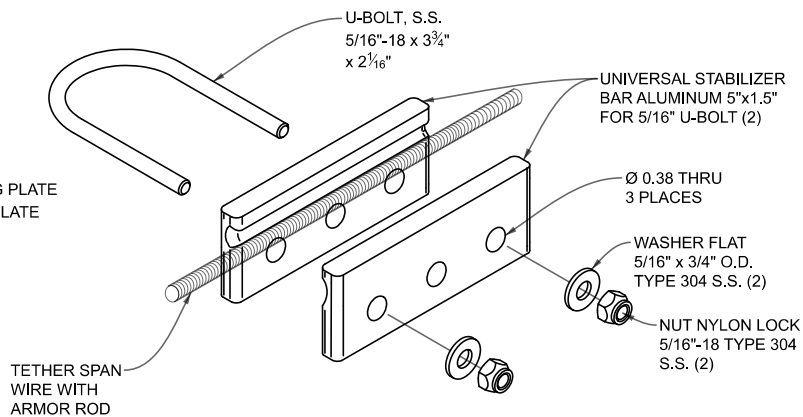

3 DETAIL - BREAKAWAY TETHER ASSEMBLY FOR TOP OF SIGNAL HEAD

APPROVED BY: _____
DIRECTOR, BUREAU OF FIELD SERVICES

APPROVED BY: _____
DIRECTOR, BUREAU OF DEVELOPMENT



DEPARTMENT DIRECTOR
BRADLEY C. WIEFERICH, PE

STANDARD PLAN FOR
SPAN WIRE TOP TETHER DETAILS

(SPECIAL DETAIL)
FHWA APPROVAL

07/27/23
PLAN DATE

SIG-305-D

SHEET
1 OF 5

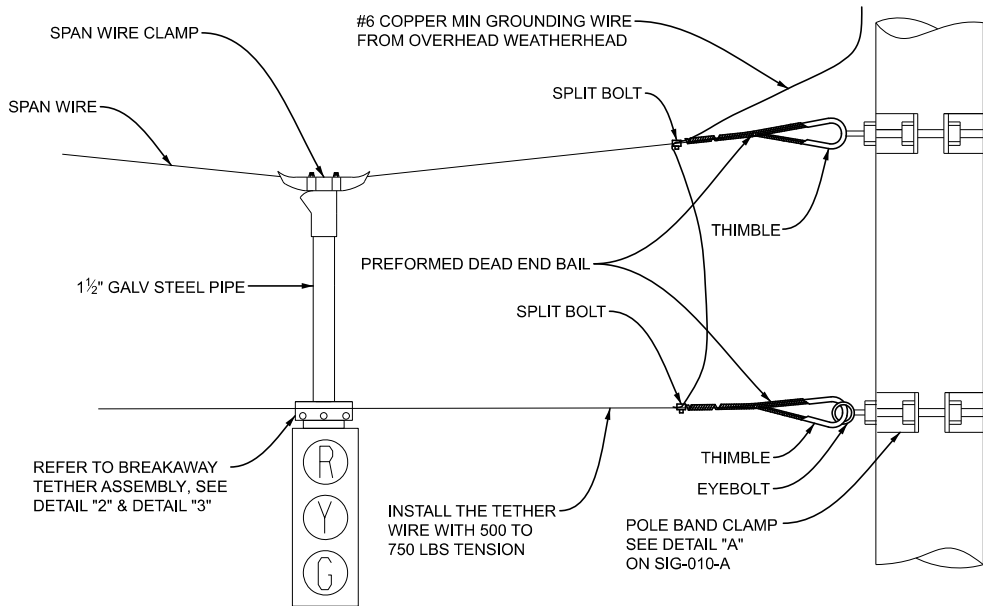

4 TOP TETHER SPAN WIRE STEEL POLE CONNECTION

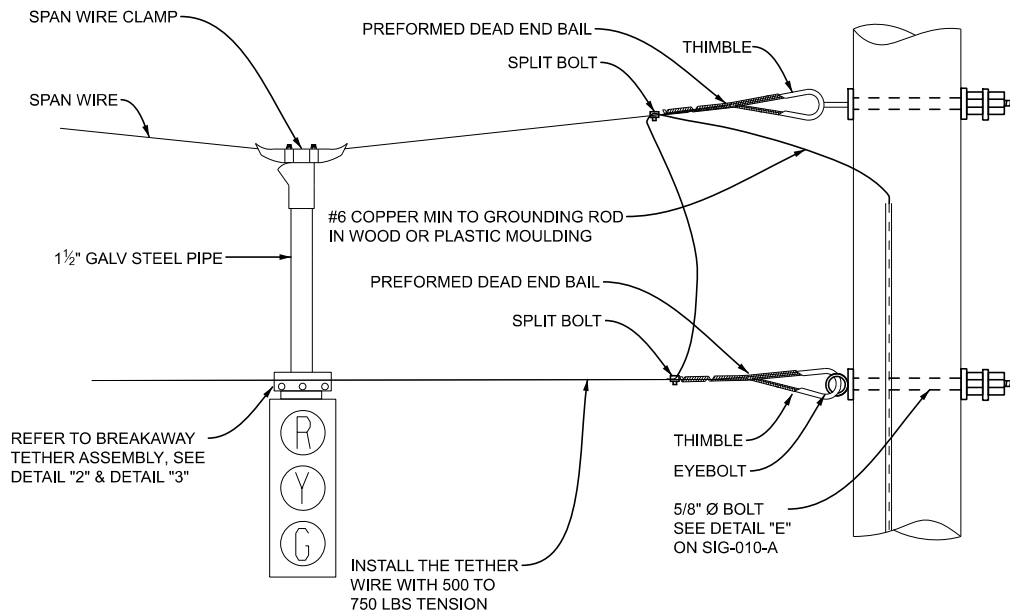

5 TOP TETHER SPAN WIRE WOOD POLE CONNECTION

MDOT
Michigan Department of Transportation

DEPARTMENT DIRECTOR
BRADLEY C. WIEFERICH, PE

STANDARD PLAN FOR TOP TETHER CONNECTION DETAILS			
(SPECIAL DETAIL)	07/27/23	SIG-305-D	SHEET
FHWA APPROVAL	PLAN DATE		2 OF 5

SECT

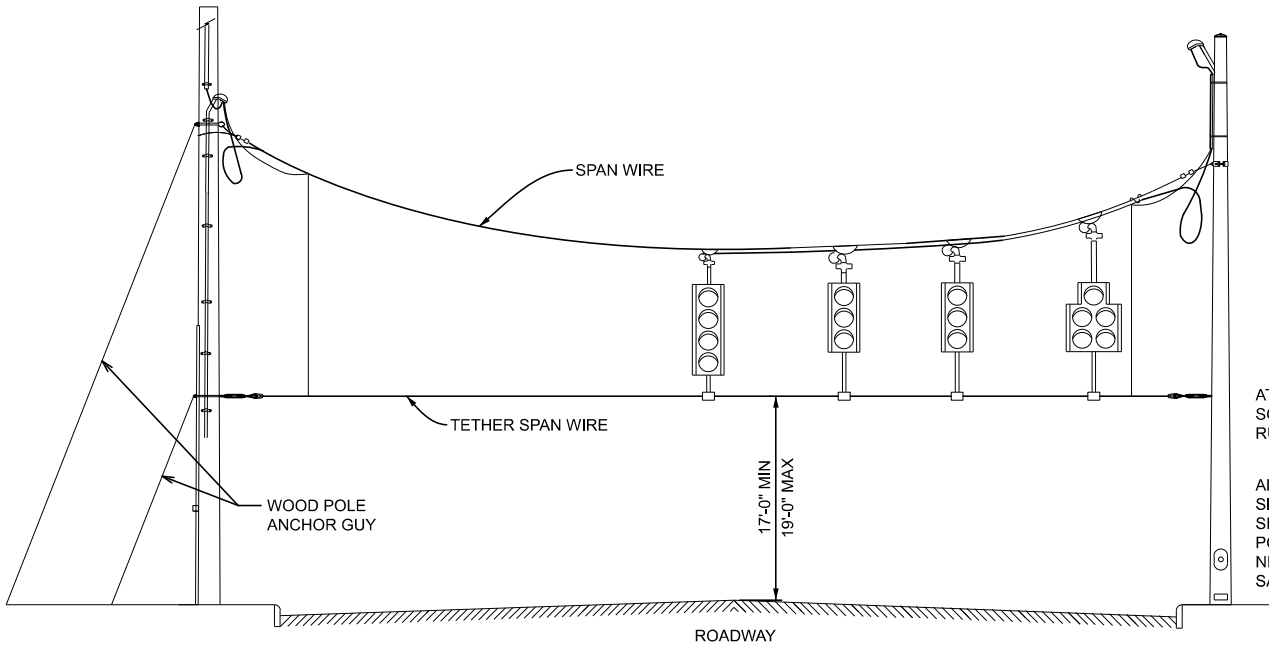

ATTACH TETHER ASSEMBLY SO THAT TETHER SPAN WIRE RUNS STRAIGHT ACROSS.

ALL VEHICLE SIGNALS AND SIGNS HUNG ON A SPAN SHALL BE TETHERED. SPAN POLE CONTACT HEIGHTS NEED NOT BE AT THE SAME ELEVATION.

6 BOTTOM TETHER INSTALLATION

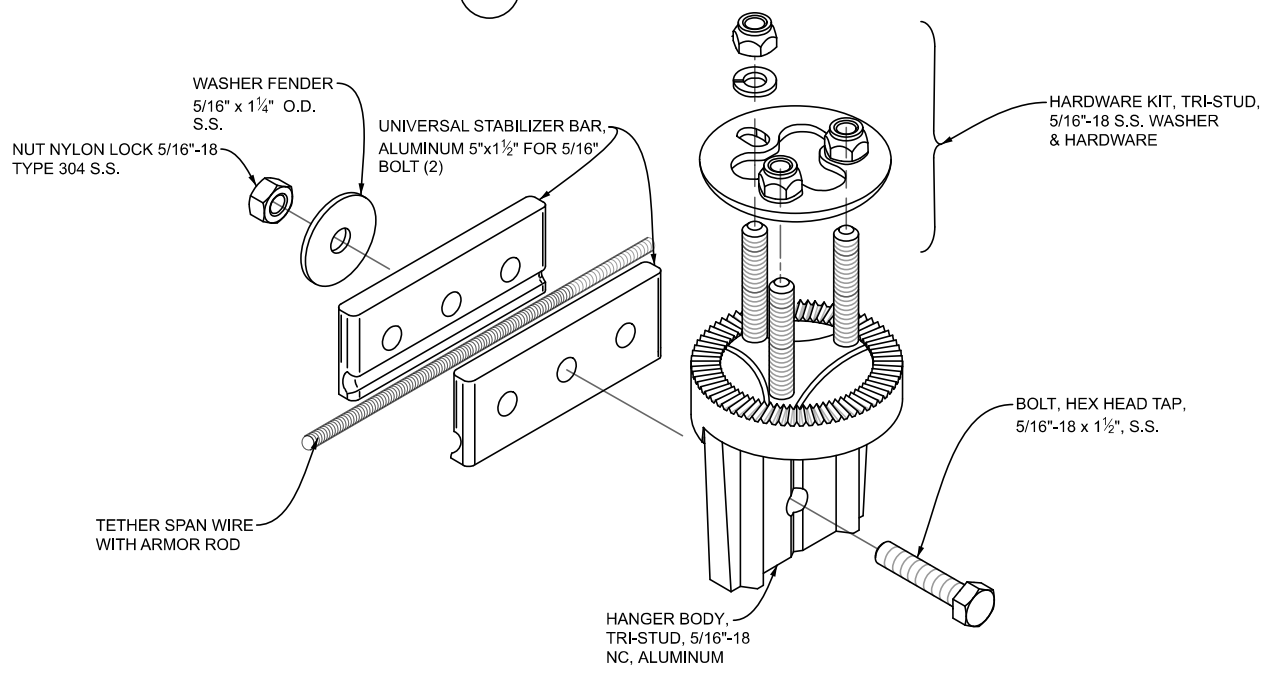

7 DETAIL - TETHER ASSEMBLY TRI-STUD BREAKAWAY

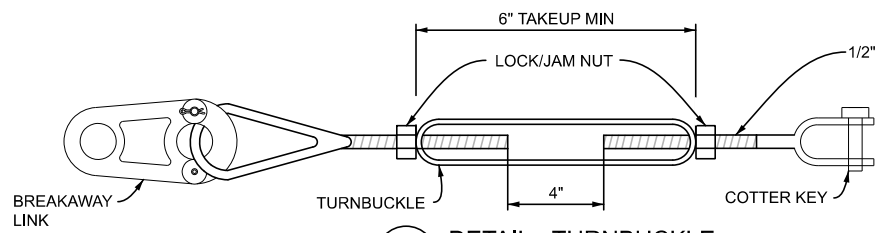
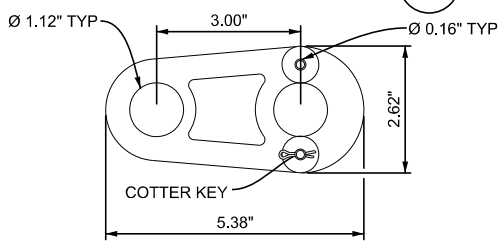

9 DETAIL - TURNBUCKLE

8 DETAIL - BREAKAWAY TETHER ASSEMBLY FOR BOTTOM OF SIGNAL HEAD

<p>MDOT Michigan Department of Transportation</p> <p>DEPARTMENT DIRECTOR BRADLEY C. WIEFERICH, PE</p>	<p>STANDARD PLAN FOR SPAN WIRE BOTTOM TETHER DETAILS</p>			<p>SIG-305-D</p>	<p>SHEET 3 OF 5</p>
	<p>(SPECIAL DETAIL) FHWA APPROVAL</p>	<p>07/27/23 PLAN DATE</p>			

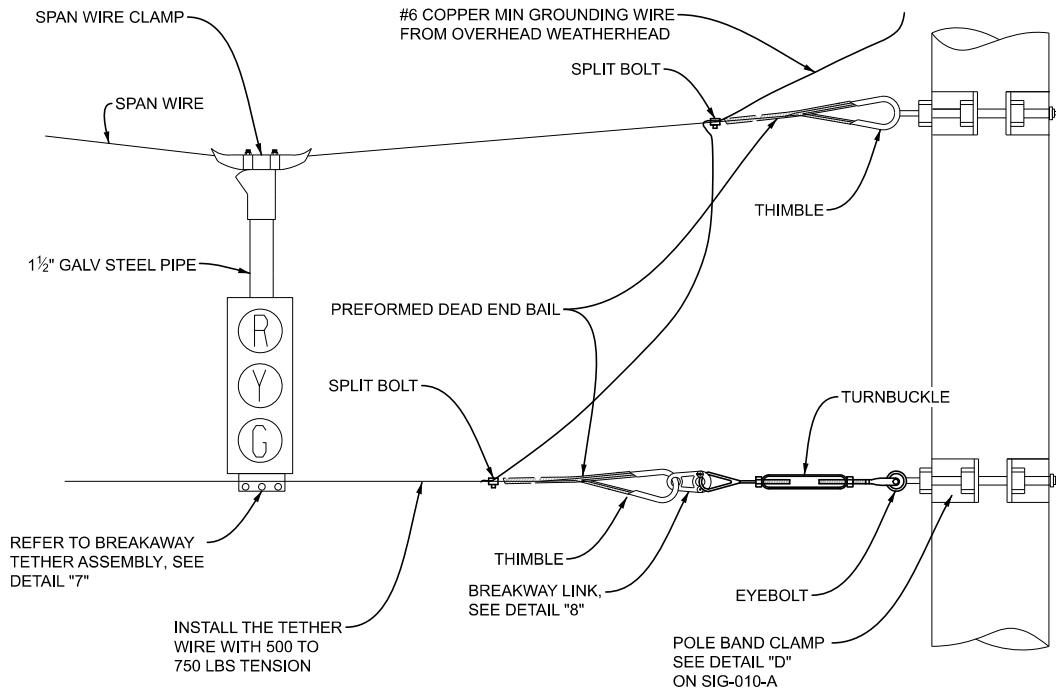

10 BOTTOM TETHER SPAN WIRE STEEL POLE CONNECTION

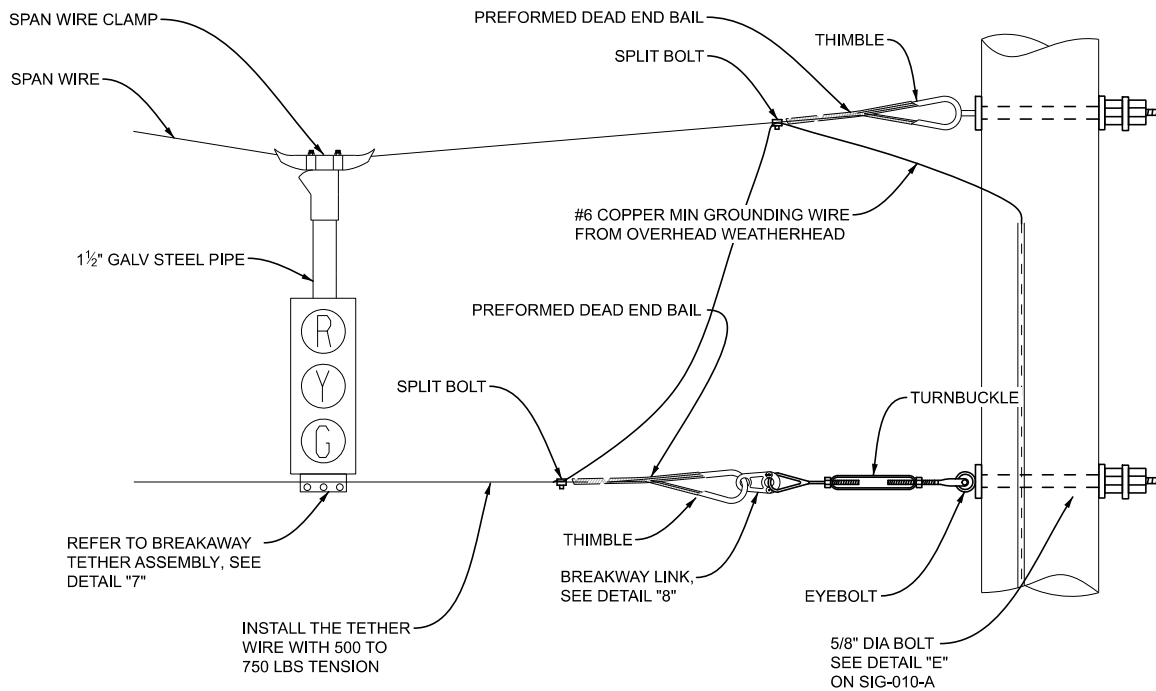

11 BOTTOM TETHER SPAN WIRE WOOD POLE CONNECTION

 DEPARTMENT DIRECTOR BRADLEY C. WIEFERICH, PE	STANDARD PLAN FOR BOTTOM TETHER CONNECTION DETAILS			SIG-305-D	SHEET 4 OF 5
	(SPECIAL DETAIL) FHWA APPROVAL	07/27/23 PLAN DATE			SECT

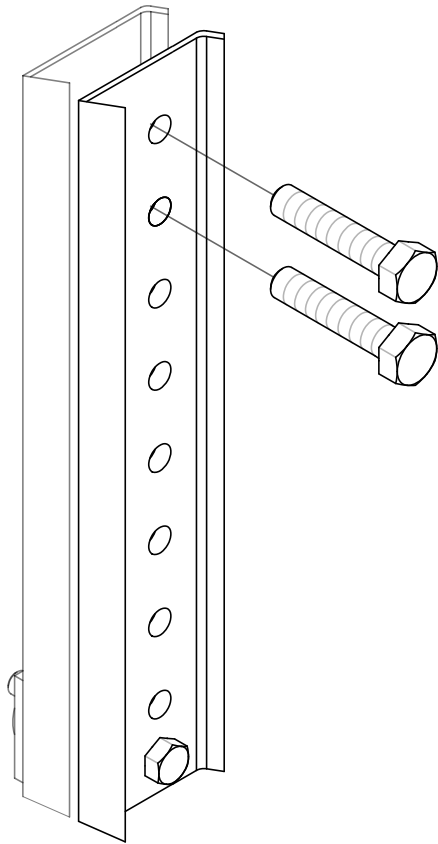

12 EXTENDER OPTION 8", 11", 19", 24", & 72 (CUT TO LENGTH)

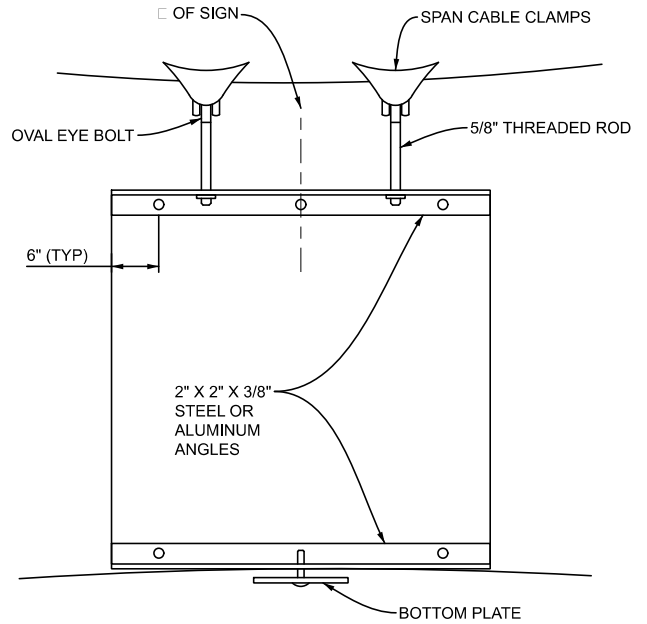

13 DETAIL - OVERHEAD LANE ASSIGNMENT SIGN CONNECTION

NOTES:

1. BREAKAWAY LINK AND TURNBUCKLE ARE REQUIRED AT BOTH ENDS OF ALL BOTTOM TETHER SPANS. IF BREAKAWAY LINK BEGINS TO YIELD DURING INSTALLATION, IT SHALL BE REMOVED AND REPLACED. THE WIRE TENSION SHALL BE ADJUSTED TO MINIMIZE MOVEMENT OF SIGNAL HEADS IN HIGH WINDS. TYPICAL TENSION IS 500 TO 750 LBS.
2. INSTALL GROUND WIRE AT BOTH ENDS OF TOP AND BOTTOM TETHERING.
3. IF SIGNAL ORIENTATION IS NOT PERPENDICULAR TO SPAN AND TETHER WIRE, THEN USE AN ANCHOR EXTENSION. CLAMP ASSEMBLY MUST BE ATTACHED TO THE FLAT SIDE OF THE EXTENDER BAR.
4. GROUNDING WIRE ANCHOR HEIGHT TO THE SPAN WIRE IS ADJUSTED IN THE FIELD BEFORE BREAKAWAY LINK IS INSTALLED. GROUNDING WIRE LENGTH SHALL BE ADJUSTED SO THAT THE MINIMUM VERTICAL CLEARANCE OF THE SAGGING TETHER WIRE ABOVE THE PAVEMENT WITHOUT THE BREAKAWAY LINK INSTALLED IS AT LEAST 14'. GROUNDING WIRE SHALL CONTAIN ENOUGH SLACK FOR HEAD TO SWAY IN HIGH WINDS. GROUNDING WIRE SHALL BE ATTACHED TO THE SPAN WIRE USING A TINNED COPPER SPLIT BOLT.
5. TRAFFIC SIGNAL HOUSING REINFORCEMENT PLATES ARE REQUIRED WHEN TETHERING.
 - A. TOP TETHERING REQUIRES REINFORCEMENT PLATES AT THE TOP OF THE POLYCARBONATE HOUSING. (2 PLATES TOTAL)
 - B. BOTTOM TETHERING REQUIRES REINFORCEMENT PLATES AT THE TOP AND BOTTOM OF POLYCARBONATE HOUSING. (4 PLATES TOTAL)
 - C. BOTTOM TETHERING 5-SECTION HEADS REQUIRES REINFORCEMENT PLATES ON THE TOP AND BOTTOM OF THE POLYCARBONATE HOUSING (12 TOTAL) AND AN ALUMINUM TRI-STUD UPPER ARM ASSEMBLY IN PLACE OF THE BOTTOM BRACKET.
 - D. IF POLYCARBONATE HOUSING CONNECTS TO AN ALUMINUM CASE SIGN, REINFORCEMENT PLATES MUST BE USED AT THE CONNECTION.

NOTES:

1. ALUMINUM ANGLES SHALL BE USED FOR ALUMINUM SIGNS (TYPE III).
2. STEEL OR ALUMINUM ANGLES MAY BE USED ON PLYWOOD SIGNS (TYPE II).



DEPARTMENT DIRECTOR
BRADLEY C. WIEFERICH, PE

STANDARD PLAN FOR
EXTENDER OPTION AND OVERHEAD LANE
ASSIGNMENT SIGN CONNECTION DETAILS

(SPECIAL DETAIL)
FHWA APPROVAL

07/27/23
PLAN DATE

SIG-305-D

SHEET
5 OF 5

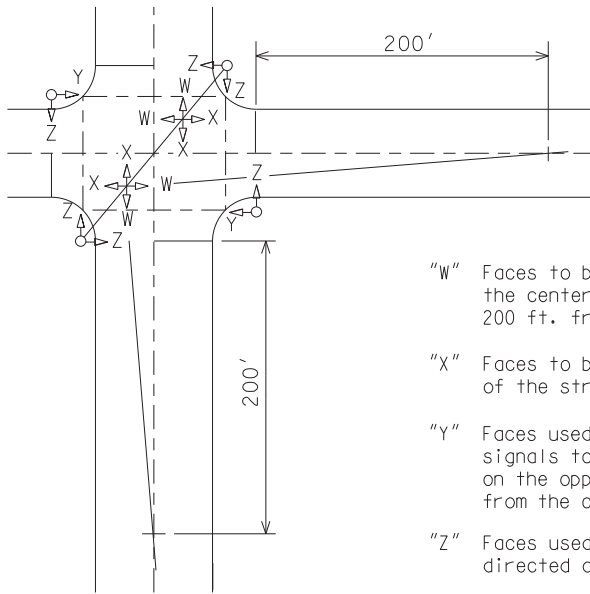

NOTE:
 Where field conditions require deviation from these standards, Engineer will furnish specific directional setting for signals at time of installation.

"W" Faces to be directed to intersect a point on the centerline of the street they control 200 ft. from the stop bar.

"X" Faces to be directed parallel to the centerline of the street they control.

"Y" Faces used as starting signals with near side signals to be directed to intersect a point on the opposite stop bar approximately 4 ft. from the curb.

"Z" Faces used as pedestrian signals to be directed along crosswalks.

DIAGONAL SPAN WIRE STANDARD FOR DIRECTIONAL SETTINGS OF TRAFFIC SIGNALS

NOT TO SCALE

File: RefDoc/TR/Signals/Web/Sp Det/Fin/SIG310A.dgn Rev: 02/16/17



PREPARED BY
 TRAFFIC AND SAFETY

DRAWN BY: DJF

CHECKED BY:

 ENGINEER OF DELIVERY

 ENGINEER OF DEVELOPMENT

(SPECIAL DETAIL)

FHWA APPROVAL DATE

MICHIGAN DEPARTMENT OF TRANSPORTATION
 BUREAU OF HIGHWAYS DELIVERY STANDARD PLAN FOR
**ALIGNMENT OF TRAFFIC
 SIGNAL HEADS (DIAGONAL)**

 PLAN DATE

SIG-310-A

SHEET
 1 of 1

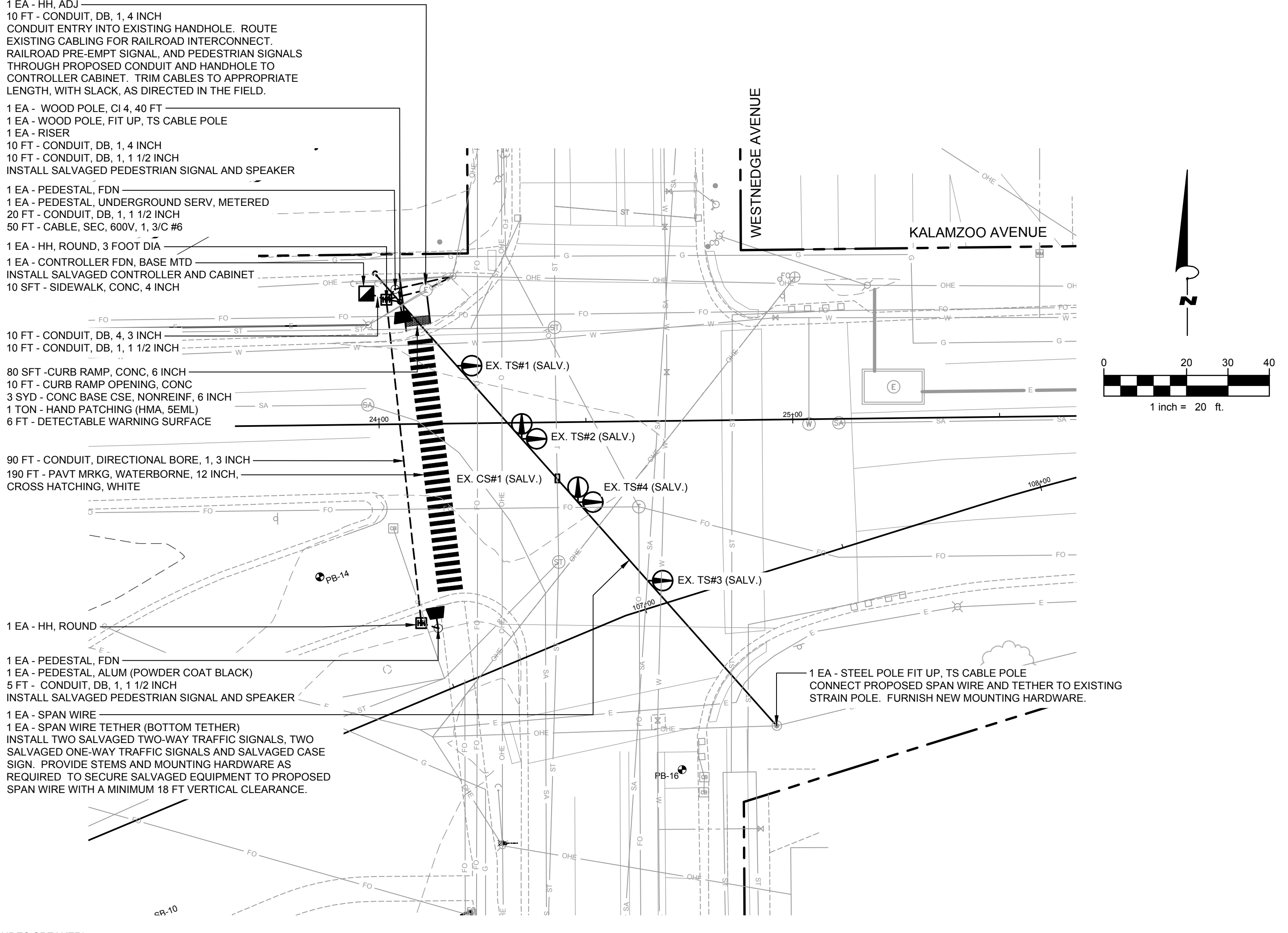
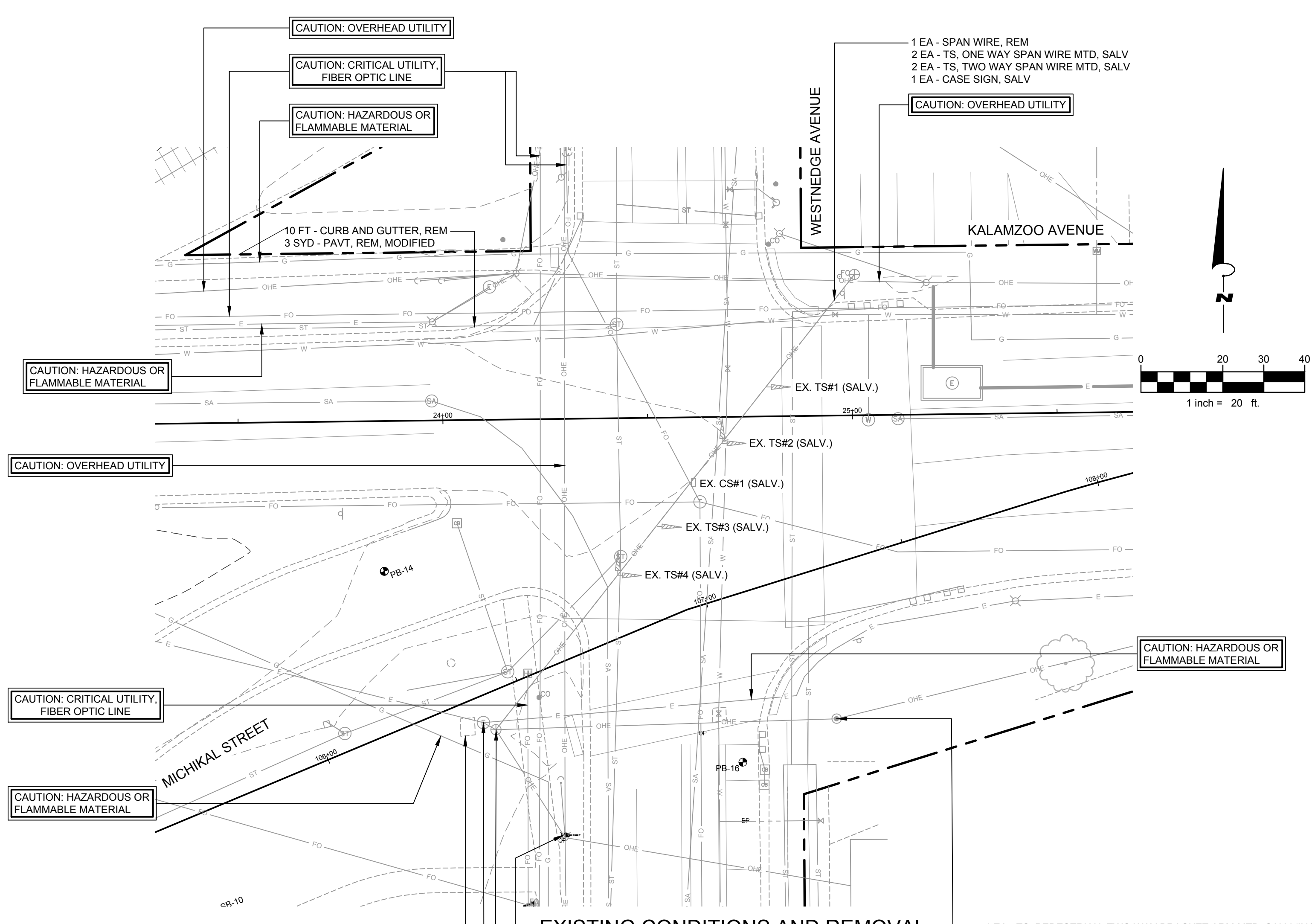

PROJECT SPECIFIC NOTES

MDOT SPECIFICATIONS
 THE MICHIGAN DEPARTMENT OF TRANSPORTATION 2020 STANDARD SPECIFICATIONS FOR CONSTRUCTION, FREQUENTLY USED SPECIAL PROVISIONS, STANDARD PLANS, SPECIAL DETAILS, AND MAINTAINING TRAFFIC TYPICALS ARE HEREBY INCORPORATED INTO THIS CONTRACT.

MMUTCD
 THE PLACING OF TRAFFIC CONTROL SIGNS, SIGNALS, AND PAVEMENT MARKINGS SHALL BE DONE IN ACCORDANCE WITH THE 2011 MICHIGAN MANUAL ON UNIFORM TRAFFIC CONTROL DEVICES (MMUTCD), AS AMENDED.

STANDARDS
 ALL WORK SHALL CONFORM TO ALL LOCAL, STATE AND FEDERAL LAWS, RULES AND REGULATIONS IN FORCE AT THE TIME OF CONSTRUCTION.

ELECTRICAL SERVICE INSPECTION
 FOR ELECTRICAL SERVICE INSPECTION, CONTACT THE MICHIGAN DEPARTMENT OF CONSUMER AND INDUSTRY SERVICES. COST FOR THE INSPECTION IS NOT A SEPARATE PAY ITEM AND IS INCLUDED IN THE PAY ITEM: CONTROLLER CABINET, MODIFIED.

GUY WIRES
 INSTALL NEW GUY WIRES BETWEEN WITH A RATIO BETWEEN 1:1 AND 1:4

WHERE SPACE CONSTRAINTS DO NOT PERMIT ANCHORING WITHIN THE RIGHT-OF-WAY/EASEMENT OR WHERE A MINIMUM OF 10'-0" VERTICAL CLEARANCE CANNOT BE MAINTAINED OVER A PEDESTRIAN OR NON-MOTORIZED PATH, INSTALL A STRUT-TYPE GUY WIRE OF SUFFICIENT LENGTH TO MAINTAIN PROPER CLEARANCES.

THE CONTRACTOR SHALL HAND DIG TO LOCATED UNDERGROUND UTILITIES PRIOR TO USE OF POWER TOOLS OR EQUIPMENT.

CABLING/WIRING
 ALL OVERHEAD WIRES & UNDERGROUND CABLES SHALL CONSIST OF COPPER CONDUCTORS AS PER THE SPECIFICATIONS.

WHERE EXISTING SIGNALS OR EQUIPMENT ARE SALVAGED OR RELOCATED, INSTALL NEW WIRING FROM THE CONTROL CABINET TO THE LOCATION OF THE SIGNAL EQUIPMENT.

THE CONTRACTOR SHALL FURNISH AND INSTALL AN ADDITIONAL 20 FEET OF SIGNAL CABLE FOR EACH PEDESTRIAN AND VEHICLE SIGNAL AS DIRECTED BY THE ENGINEER.

ALL WIRES & CABLES SHALL BE TAGGED IN A PERMANENT MANNER INDICATING THE SOURCE & USE OF EACH THIS SHALL BE DONE IN ALL MANHOLES, HANDHOLES & CABINETS WHERE THESE CABLES OR WIRES ENTER, EXIT, AND ARE TERMINATED.

NO SPLICING OF CABLES IS ALLOWED ON THIS PROJECT.

CONSTRUCTION PHASING
 MAINTAIN TRAFFIC IN ACCORDANCE WITH MDOT MAINTAINING TRAFFIC TYPICALS 160-INT-LD-CLT-MID AND 163-INT-LD-OUT.

CONDUITS
 ALL CONDUIT BENDS SHALL HAVE MINIMUM RADII IN ACCORDANCE WITH THE NATIONAL ELECTRIC CODE (N.E.C.)

ALL JACKED-BORED, OPEN CUT OR DIRECT BURIAL CONDUIT CALLED FOR ON PLANS IS THE PREFERRED METHOD OF INSTALLATION. IF THE METHOD OF CONDUIT INSTALLATION IS IMPOSSIBLE TO CONSTRUCT OR IF THE CONTRACTOR PREFERS TO USE ANY OTHER METHOD, THE CHANGE OF METHOD MAY BE MADE UPON APPROVAL BY THE PROJECT ENGINEER.

THE CONTRACTOR IS RESPONSIBLE FOR DETERMINING OR ANTICIPATING THE NEED OR DESIRE TO INSTALL THE CONDUIT BY ANY OTHER METHOD AND INCLUDE THE COST IN HIS CONTRACT BID.

NO ADDITIONAL PAYMENT WILL BE ALLOWED FOR ANY CHANGE IN THE METHOD OF CONDUIT INSTALLATION.

THE CONTRACTOR SHALL LOCATE, PROTECT, AND (WHERE APPROPRIATE) UTILIZE PREVIOUSLY INSTALLED TRAFFIC SIGNAL CONDUIT FOR USE AS PART OF THIS PROJECT.

WHEN PLACING NEW HANDHOLE ON EXISTING CONDUIT, INSTALL SWEEPS, BREAK OUT CONDUIT, AND ADAPT HANDHOLE AS NEEDED. INCLUDED WITH PAYMENT FOR NEW HANDHOLE.

INNERDUCT
 CONTRACTOR MUST INSTALL A CONTINUOUS FLEXIBLE NON-METALLIC TUBING (INNERDUCT) FOR LOW VOLTAGE COMMUNICATION TYPE CABLE FROM THE DEVICE TO THE CONTROLLER CABINET. INNERDUCT IS NOT REQUIRED IF COMMUNICATION CABLE IS 600V RATED.

NOTES

EXCEPT WHERE OTHERWISE INDICATED ON THESE PLANS OR IN THE PROPOSAL AND SUPPLEMENTAL SPECIFICATIONS CONTAINED THEREIN, ALL MATERIALS AND WORKMANSHIP SHALL BE IN ACCORDANCE WITH THE 2020 MICHIGAN DEPARTMENT OF TRANSPORTATION STANDARD SPECIFICATIONS FOR CONSTRUCTION.

THE PLACING OF PAVEMENT MARKINGS AND TRAFFIC CONTROL SIGNS SHALL BE DONE IN ACCORDANCE WITH THE 2011 MICHIGAN MANUAL ON UNIFORM TRAFFIC CONTROL DEVICES AS AMENDED.

IN CONFORMANCE WITH PUBLIC ACT 174 OF 2013, ALL CONTRACTORS SHALL CALL MISS DIG @ 811 OR 800-482-7171 FOR PROTECTION OF UNDERGROUND UTILITIES A MINIMUM OF THREE FULL WORKING DAYS (EXCLUDING SATURDAYS, SUNDAYS AND HOLIDAYS) PRIOR TO BEGINNING EACH EXCAVATION IN ANY AREA. MEMBERS WILL BE ROUTINELY NOTIFIED. THIS DOES NOT RELIEVE THE CONTRACTOR OF THE RESPONSIBILITY OF NOTIFYING UTILITY OWNERS WHO MAY NOT BE A PART OF THE "MISS DIG" ALERT SYSTEM.

CONSTRUCTION WILL BE OCCURRING IN THE PROJECT AREA FOR THE KALAMAZOO EVENT CENTER AND ARCADIA CREEK RELOCATION PROJECT. EXISTING SITE CONDITIONS MAY VARY FROM WHAT IS SHOWN DUE TO THIS WORK. THE CONTRACTOR SHALL BE REQUIRED TO COORDINATE THEIR WORK WITH THESE PROJECTS. ADDITIONAL COMPENSATION WILL NOT BE PROVIDED FOR EFFORTS REQUIRED TO COORDINATE WITH ADJACENT PROJECTS OR DUE TO CHANGED SITE CONDITIONS.

SIGNALS

INCLUDED CONSTRUCTION
 IN ACCORDANCE WITH SECTION 820.04 A OF THE STANDARD SPECIFICATIONS, THE UNIT PRICES FOR WORK RELATED TO TRAFFIC SIGNAL ITEMS INCLUDING EXCAVATION AND BACKFILL (INCLUDING BACKFILL OF REMOVED ITEMS), TURF RESTORATION, STORAGE AND DISPOSAL OF WASTE MATERIAL, PLACING MARKING TAPE, AND CHANGES IN THE METHOD OF CONDUIT INSTALLATION REQUESTED BY THE CONTRACTOR.

NOTIFICATION TO MAINTAINING AGENCIES
 CONTACT THE MAINTAINING AGENCY SEVEN (7) WORKING DAYS PRIOR TO START OF CONSTRUCTION AND SEVEN (7) WORKING DAYS PRIOR TO SIGNAL ACTIVATION.

CABINET SETUP AND CONTROLLER TIMING
 TRAFFIC SIGNAL CONTROLLERS SHALL BE SETUP AND PROGRAMMED BY A FACTORY AUTHORIZED DEALER WITH TIMING PLANS FURNISHED BY THE ENGINEER OR MAINTAINING AGENCY. TRAFFIC SIGNAL CONTROLLERS SHALL BE FURNISHED WITH A COMPLETE SET OF INSTALLATION PLANS AND OWNERS MANUAL. THE ITEM FOR CONTROLLER AND CABINET, SALV SHALL INCLUDE ALL WORK REQUIRED TO SALVAGE ALL EXISTING EQUIPMENT IN THE CABINET AND PLACE IN SERVICE AT THE PROPOSED LOCATION.

FACILITIES NOT ON PLANS
 EXISTING O.H. & T.S. FACILITIES ARE NOT NECESSARILY SHOWN ON THE PLANS

SIGNAL EQUIPMENT DISPOSAL
 DISPOSAL OF ALL TRAFFIC SIGNAL EQUIPMENT IS INCLUDED IN THE REMOVAL PAY ITEMS AND SHALL ALSO INCLUDE THE FOLLOWING:
 1. NOTIFICATION TO THE MAINTAINING AGENCY THAT TRAFFIC SIGNAL EQUIPMENT IS BEING REMOVED.
 2. TEMPORARY STORAGE OF EQUIPMENT AS DIRECTED BY THE ENGINEER ALLOWING THE MAINTAINING AGENCY 48 HOURS TO SALVAGE ANY EQUIPMENT.
 3. PROPER DISPOSAL OF ANY EQUIPMENT CONTAINING ENVIRONMENTALLY SENSITIVE MATERIALS (MERCURY RELAY SWITCHES FOR EXAMPLE)
 4. DISABLING OR DESTRUCTION OF ALL REMAINING EQUIPMENT TO THE SATISFACTION OF THE ENGINEER SUCH THAT IT CANNOT BE REUSED OR RESOLD.
 5. PROPER DISPOSAL OF ALL REMAINING EQUIPMENT.

PLAN DEVIATIONS DURING CONSTRUCTION
 NO CHANGES FROM PLANS IN LOCATION OF SUPPORTING STRUCTURES, SIGNAL HEAD PLACEMENT OR TRAFFIC SIGNAL EQUIPMENT WILL BE ALLOWED WITHOUT PRIOR APPROVAL OF THE MAINTAINING AGENCY.

SIGNAL HEAD LANDING POINT
 ENSURE EACH TRAFFIC SIGNAL HEAD ASSEMBLY HAS ITS OWN LANDING POINT WITH ALL NEUTRALS CONNECTED TOGETHER WITH A METAL TYPE JUMPER.

TRAFFIC SIGNAL MOUNTING
 ALL PERMANENT TRAFFIC SIGNALS SHALL BE MOUNTED SUCH THAT 18'-0" UNDERCLEARANCE IS MAINTAINED AT ALL TIMES.

FIELD ADJUSTMENT OF TRAFFIC SIGNAL EQUIPMENT MAY BE REQUIRED AS DIRECTED BY THE ENGINEER AT NO ADDITIONAL COST TO THE PROJECT.

ALL TRAFFIC SIGNAL FITTINGS (SCREWS, NUTS, BOLTS, PINNACLES, ETC.) SHALL BE GREASED WITH NON-OXIDE TYPE GREASE.

POCH TABLE - SPAN 1

ITEM	DESCRIPTION	POCH HT. (ft)	STEM LENGTH (ft)	DIST. ALONG SPAN (ft)
POLE (NW)	PROP. WOOD POLE, 40 FT	32.5	-	0
EX. TS#1	1W-3C	-	6.58	20
EX. TS#2	2W-3C	-	2.33	45
EX. CS#1	4W ILLUMINATED	-	1.25	57
EX. TS#4	2W-3C	-	0.92	65
EX. TS#3	1W-3C	-	1.67	90
POLE (SE)	EX. STEEL POLE	28.5	-	137

MINIMUM VERTICAL CLEARANCE IS 18FT
 POCH CALCULATIONS BASED ON 1,300 LBS TENSION

ELECTRICAL WIRING NOTES:

ELECTRIC SERVICE
 600V 3/C #6AWG SEC

RAILROAD INTERCONNECT
 600V 14/C #14AWG P.J. (AREMA)

TRAFFIC SIGNAL (1W-3C):
 5/C #16AWG P.J.

TRAFFIC SIGNAL (2W-3C):
 7/C #16AWG P.J.

4-WAY ILLUMINATED CASE SIGN
 4/C #16AWG P.J.

PEDESTRIAN SIGNAL (ONE WAY)
 7/C #16AWG P.J.

PEDESTRIAN SIGNAL (TWO WAY)
 7/C #16AWG P.J.

ELECTRICAL REQUIREMENTS

OPENINGS	38
CYCLIC WATTAGE	3666
STEADY WATTAGE	250

NOTES:
 CONTRACTOR SHALL COORDINATE NEW ELECTRIC SERVICE WITH CONSUMERS ENERGY.
 CONTRACTOR SHALL PROVIDE THE ENGINEER AND UTILITY WITH THE STEADY WATTAGE REQUIREMENTS WHEN COORDINATING THE POWER.

PROPOSED WIRING DIAGRAM

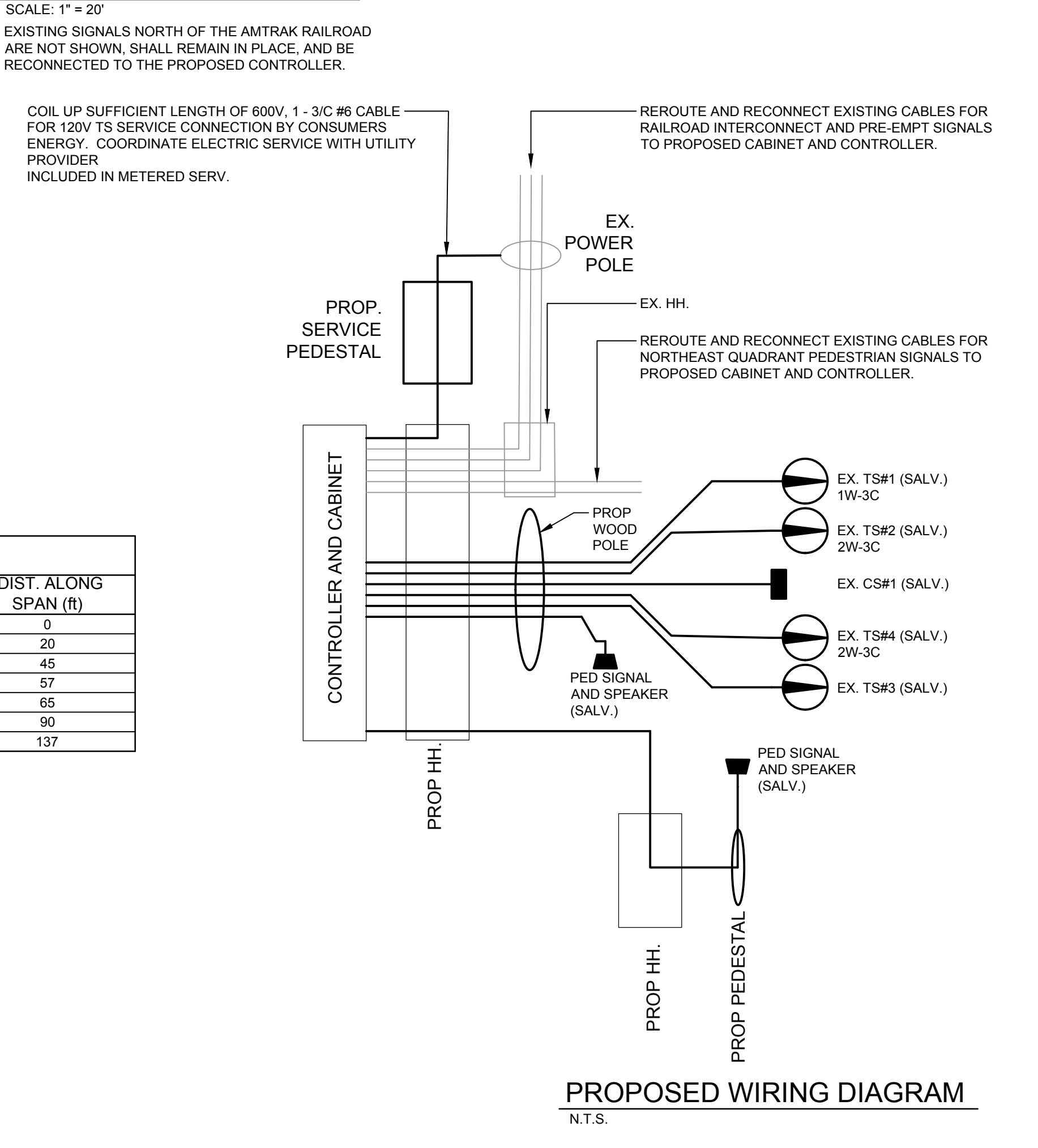



SPECIAL PROVISIONS

Michikal-Kalamazoo-Westnedge Signal

Bid Reference #: 96880-006.0

July 2025

MICHIGAN
DEPARTMENT OF TRANSPORTATION

SPECIAL PROVISION
FOR
**COATING OF GALVANIZED LIGHTING, SIGNAL, SIGN, AND MISCELLANEOUS
SUPPORT STRUCTURES**

STR:SCK

1 of 3

APPR:POJ:MJF:04-10-20
FHWA:APPR:04-13-20

a. Description. This work consists of coating galvanized structural highway appurtenances (light standards, traffic signal mast arm, strain poles, etc.) as specified in the contract and subsection 716 of the Standard Specifications for Construction except as modified herein.

b. Material. Provide a liquid or powder coating system as described below or as approved by the Engineer.

1. Coating System.

A. Provide a powder coating system with an exterior grade polyester, polyurethane, or fluoropolymer top coat; or

B. Provide a liquid coating system with an aliphatic polyurethane, polyaspartic, polysiloxane, or fluoropolymer top coat.

2. Provide top coat dry film thickness per paint manufacturer's specifications or a minimum 2 mils, whichever is greater.

3. Selected top coat must meet or exceed the requirements of *American Architectural Manufacturers Association (AAMA) 2604*.

4. Use a tie coat to promote adhesion over galvanized surfaces, if recommended by the coating manufacturer. Apply tie coat by method and thickness as recommended by the coating manufacturer.

5. Provide top coat color per plan note.

6. Provide the coating manufacturer's recommended touch-up coating as required.

The coating manufacturer must furnish certification and test results for the top coat to the Engineer to verify that the material complies with *AAMA 2604*. If the coating manufacturer also recommends a tie coat for galvanized surfaces, submit tie coat product information to the Engineer, including tie coat application method and recommended thickness.

Ensure the fabrication plant is certified by the *American Institute of Steel Construction (AISC) Sophisticated Paint Endorsement* or *Society for Protective Coatings (SSPC)-QP 3* or *Certification Standard for Shop Application of Complex Protective Coating Systems* if applying liquid coating system. Ensure fabrication plant is certified by the *Powder Coating Institute (PCI)-4000* if applying powder coating system. If the powder coating is being applied by someone other than the original

equipment manufacturer then the coating company must possess a valid PCI 3000 certification.

c. Surface Preparation. Perform surface preparation in accordance with subsection 716.03 of the Standard Specifications for Construction.

d. Coating Process for Galvanized Steel. Provide the liquid or powder coating system per the paint manufacturer's recommendations, except ensure conditions for coating are in accordance with subsection 915.04 of the Standard Specifications for Construction unless the manufacturer recommends more stringent conditions. Out gas forgiving additive in compliance with *AAMA 2604* is permitted.

The powder coating applicator must carry out a preliminary test to establish whether out-gassing from the galvanizing is likely by testing parts where the zinc is thickest. Ensure the galvanized components are heated to a temperature at least 55 degrees Fahrenheit (F) higher than the coating curing temperature as provided by the coating manufacturer. Ensure the temperature is measured at the hottest point across the object during tests. If the substrate cannot be satisfactorily degassed sufficiently to minimize further out-gassing during baking, then ensure a specially formulated anti-gassing quality powder coating, or an anti-bubbling additive as per the manufacturer's recommendations, is used to minimize out-gassing.

Apply the paint system per paint manufacturer specifications including strict adherence to curing temperature and time except where the requirements listed in section 716 of the Standard Specifications for Construction are more stringent.

e. Construction. Ensure extreme care is exercised in handling the coated components in the shop, during shipping, and erecting of the structural highway appurtenances. Ensure coated pieces are not moved or handled until sufficient cure time has elapsed to ensure no damage is done to the coating. Ensure the coated components are insulated from the binding chains by softeners approved by the Engineer. Pad hooks and slings used to hoist steel. Space structural highway appurtenances in such a way that no rubbing will occur that may damage the coating during shipment and storage. Store the components on padded pallets at the job site, or by other means approved by the Engineer, so that the pieces do not rest on the ground and so that the components do not fall or rest on each other. Provide all shipping and storage details to the Engineer and ensure they are approved prior to shipment of the structural highway appurtenance.

Ensure shop and field repairs of coating are done in accordance with coating supplier's recommendations except where the requirements listed in this specification are more stringent. Submit all written procedures for shop and field repairs including the coating of nuts, bolts, and washers for approval to the Engineer prior to coating. Do not begin coating until approval is received from the Engineer. Repair or recoat surfaces which will be inaccessible for coating after erection prior to erection. When the erection work has been completed, including all connections, prepare the steel for repairs. The cost of all repairs will be borne by the Contractor.

f. Measurement and Payment. The completed work, as described, will be measured and paid for at the contract unit price using the following pay item:

Pay Item	Pay Unit
Coating Galvanized Support Structures.....	Each

Coating Galvanized Support Structures will be measured as a unit for each complete (e.g.

STR:SCK

3 of 3

20SP-716A-01

04-10-20

traffic signal mast arm and pole) highway structure that is coated and includes the cost of surface preparation, applying the tie coating, applying the complete coating system, stenciling, applying approved sealants, and shop and field repairing the complete coating system.

Galvanizing and repair of damaged galvanized surfaces is included in the pay item for furnishing the galvanized component.

MICHIGAN
DEPARTMENT OF TRANSPORTATION

SPECIAL PROVISION
FOR
**PRECAST CONCRETE PEDESTAL SIGNAL FOUNDATION AND PRECAST
UNDERGROUND SERVICE PEDESTAL (METAL) FOUNDATION**

STR:POJ

1 of 1

APPR:RWS:MJF:06-02-20

FHWA:APPR:06-04-20

a. Description. This work consists of fabricating, furnishing, and installing precast concrete foundations to be used for pedestal pedestrian signals and underground service pedestals (metal), as shown in the contract, and in accordance with the standard specifications except as modified herein.

b. Materials.

1. Concrete. Use concrete grade 3500 or 3500HP in accordance with section 1004 of the Standard Specifications for Construction.
2. Anchor bolts. Use *ASTM F1554 Grade 36*.
3. Reinforcing Steel. Must meet section 905 of the Standard Specifications for Construction.
4. Open-Graded Aggregate, 34R.

c. Fabrication. Fabricate at a commercial precast facility certified by *Precast/Prestress Concrete Institute (PCI)*, *National Precast Concrete Association (NPCA)*, or *American Concrete Pipe Association (ACPA)*. Provide quality control and notify the Engineer prior to fabrication to provide the opportunity for quality assurance inspection. The Engineer may elect to forego this inspection but not the certification requirements. Provide steel reinforcement as necessary to protect foundations from any shipping, handling, or installation damage. Precast foundations are subject to rejection by the Engineer for visible damage or improper material documentation during fabrication and at time of delivery and installation.

d. Construction. Ensure precast pedestal signal foundations are placed plumb and level in the excavation on 6 inches of 34R open-graded aggregate, with an annular space of 3-6 inches. Fill the annular space with 34R in one-foot lifts and compact each lift. Restore disturbed areas in kind in accordance with section 816.

e. Measurement and Payment. The completed work, as described, will not be paid for separately but will be included in the associated pay item(s) covered in subsection 820.04 of the Standard Specifications for Construction.

MICHIGAN
DEPARTMENT OF TRANSPORTATION

SPECIAL PROVISION
FOR
SPAN WIRE TETHER

SIG:EMS

1 of 1

APPR:NJB:HLO:03-21-24
FHWA:APPR:03-18-24

a. Description. This work consists of furnishing and installing hardware, connector hangers, fittings, stabilizer bar, pole clamps, tri-stud and 2 nested extension plates, 22 inches minimum length associated stainless steel fasteners and a span wire tether.

Bottom tether or top tether traffic signal heads as shown on plans or as directed by the Engineer.

b. Materials. Furnish material meeting the requirements of sections 818, 820, and 921 of the Standard Specifications for Construction.

- 1. Furnish tether span wire that is 5/16 inch nominal diameter for spans without tie-offs or with tie-offs, extra high-strength grade, 7-strand, galvanized, Class A, zinc-coated steel meeting the requirements of *ASTM A475*. Maintain clearance of 17 feet over roadway.
- 2. Ensure pole clamps, turnbuckle, tether wire to breakaway link connection, and all other components in the load path from the wire to the pole are galvanized steel.
- 3. Ensure three-way pull-off clamp or bull ring, galvanized or stainless, can resist a single pull load of 6,570 pounds minimum. Ensure breakaway link breaks at 3,325 pounds.
- 4. Materials will be accepted based on certification and visual inspection.

c. Construction. Complete this work in accordance with sections 818, 820 and 921 of the Standard Specification for Construction, as shown on the plans, and as directed by the Engineer.

Where installation is specified, install the span wire tether on existing or new signal head(s) at location(s) shown on the plans. Furnish, install, remove, or install on the project, a span wire tether, as shown on the plans or as directed by the Engineer.

d. Measurement and Payment. The completed work, as described, will be measured and paid for at the contract unit price using the following pay item:

Pay Item	Pay Unit
Span Wire Tether	Each

MICHIGAN
DEPARTMENT OF TRANSPORTATION

SPECIAL PROVISION
FOR
TRAFFIC SIGNAL WORK - CONSTRUCTION METHODS

SIG:EMS

1 of 2

APPR:HLO:NJB:04-29-20
FHWA:APPR:05-06-20

a. Description. This special provision is for electrical construction and/or relocation of traffic signal facilities is to be used in addition to the applicable sections of the standard specifications. In case of conflict use whichever is most restrictive.

b. Materials. Furnish new material and equipment, unless specified otherwise, and comply with sections 918 and 921 of the Standard Specifications for Construction. Materials furnished by the Department to the Contractor will be picked up by the Contractor at such site as designated by either MDOT, or the Local Agency representing MDOT, with any associated costs included in pay items as indicated on the plans and will not be paid for separately.

1. General. Provide manufacturer's certifications, in accordance with the specifications, for all wire and cable and other items or as directed by the Engineer. Do not install any wire or cable before it has been approved by the Engineer. Include statement "Materials are in accordance with the Specifications" on their material order, especially on wire and cable.

Reuse only the best of the existing material and equipment where the contract calls for reuse of existing material and equipment as directed by the Engineer. The Department will have the right to furnish the Contractor with a new part if any are found defective prior to dismantling. Any part or parts damaged by the Contractor subsequent to starting the removal are a liability of the Contractor.

Furnish the Engineer an as-built record of all underground or overhead work installed within 5 days after completion of each section of the underground conduit, cable or overhead line work. This record must include the size and length of cable and duct lines, location of the lines, handholes and manholes, and location and size of support poles. Tag and stamp all wires and cables using a brass tag indicating the source and use of the cable.

Connect the ground wire to the ground rod with a UL rated copper or bronze ground clamp.

c. Construction. All work must comply with sections 819 and 820 of the Standard Specifications for Construction, the applicable "typical" signal construction details, this special provision, and requirements of the *NEC, National Electrical Safety Code (NESC)*, and the Michigan Department of Licensing and Regulatory Affairs (LARA). Contact the LARA for electric service inspection and be responsible for payment of all applicable fees.

1. Maintain all existing street lighting, traffic signal, primary, transmission, communication cables, etc. circuits in an operational condition, unless otherwise noted on the plans or as directed by the Engineer.

2. In addition to subsections 104.07 and 812.03 of the Standard Specifications for

Construction, the following applies to Contractor maintenance of permanent or temporary traffic signal installations which are being worked on by the Contractor:

A. The Contractor is responsible for maintaining any portion of a traffic signal which has been worked on by the Contractor until final acceptance of that specific location.

B. If MDOT forces are required to work on an emergency traffic signal malfunction that is determined to have been caused by the work of a Contractor, the cost of the work will be the responsibility of the Contractor.

C. If vandalism occurs to equipment that is not energized, the Contractor is responsible for replacement.

3. Utility Coordination. Notify the System Operating Division of the local utility 72 hours in advance of any work on underground or overhead transmission or distribution circuits. If possible, the System Operating Division will shutdown and red tag the line by 8 a.m. for the day requested. Notify the System Operating Division when the work is complete.

Provide coordination and make arrangements, as described above, to work on traffic signal circuits.

Schedule, coordinate, install, and pay for work provided by the local utility company(s), as indicated on the plans or as directed by the Engineer. The Engineer will not authorize payment for delay caused by the Contractor's failure to properly schedule and coordinate any utility work.

4. Agency Coordination. Secure all necessary permits covering the operations, including permits from the Public Authorities having jurisdiction over the streets, or other Public Properties in which the work is located, and the improvements therein. Obtain the amount of any charges for payment, including fees or inspection charges required by such authorities, and include the cost of these fees in the bid prices.

The local traffic authority may impose restrictions regarding particular times of certain days of the week wherein the Contractor cannot perform work and may, in fact, be required to clear the area of work obstacles or construction equipment. The Contractor must take note of this and there will be no extra payment to perform the work with possible restrictions imposed. The Engineer will not authorize extra payment if the Contractor chooses to perform work during overtime status.

5. Ensure construction is performed by persons who are experienced and qualified for the work required. On-site licensed (Journeyman electrician) supervision is required for the electrical system installation (including placement of traffic loops, conduits, and/or cables in dirt, foundations, and handholes) and must be present at all times when electrical construction is in progress. Ensure the ratio of electrical journeymen or master electricians to registered apprentice electricians is on the basis of one electrical journeyman or master electrician to one registered apprentice electrician in accordance with Michigan Law section 338.883e. This ratio is to be enforced on a jobsite basis. For traffic signal work a single jobsite is defined as a single intersection or single electronic traffic control device.

MICHIGAN
DEPARTMENT OF TRANSPORTATION

SPECIAL PROVISION
FOR
SPAN WIRE

SIG:EMS

1 of 1

APPR:MLO:SCK:07-31-23
FHWA:APPR:08-08-23

a. Description. This work consists of furnishing and installing hardware, connector hangers, fittings, bull rings or three-way pull-off connections, span wire clamps, pole band clamps, associated stainless steel fasteners and a span wire.

b. Materials. Furnish material meeting the requirements of sections 818, 820, and 921 of the Standard Specifications for Construction.

1. Furnish span wire that is 5/16 inch nominal diameter for spans without tie-offs and 1/2 inch nominal diameter for spans with tie-offs, extra high-strength grade, 7-strand, galvanized, Class A, zinc-coated steel meeting the requirements of *ASTM A475*. Maintain clearance of 17 feet over roadway.

2. Ensure pole clamps and all other components in the load path from the wire to the pole are galvanized steel, capable of resisting a load of 6,570 pounds minimum for 5/16 inch nominal diameter span wire and 13,705 pounds minimum for 1/2 inch nominal diameter span wire without permanent distortion.

3. Ensure three-way pull-off connection or bull ring, galvanized or stainless steel, can resist a single pull load of 13,705 pounds minimum.

4. Materials will be accepted based on certification and visual inspection.

c. Construction. Complete this work in accordance with sections 818, 820 and 921 of the Standard Specifications for Construction, as shown on the plans, and as directed by the Engineer.

d. Measurement and Payment. The completed work, as described, will be measured and paid for at the contract unit price using the following pay item:

Pay Item	Pay Unit
Span Wire	Each

MICHIGAN
DEPARTMENT OF TRANSPORTATION

SPECIAL PROVISION
FOR
PEDESTAL, UNDERGROUND SERVICE, METERED AND UNMETERED

SIG:EMS

1 of 2

APPR:BA:HLO:05-05-20
FHWA:APPR:05-06-20

a. Description. This work consists of installing or removing a complete pedestal for underground (UG) electrical service, either metered and/or unmetered. A complete pedestal UG electrical service includes the pedestal, meter socket (as required), brackets, hardware, fittings, connectors, cable, conduit, risers, grounding, and all appurtenant material required to complete the work.

b. Materials. Provide pedestal(s) in accordance with this special provision. Provide hardware, connectors, cable, conduit, and all other appurtenant materials in accordance with sections 918 and 921 of the Standard Specifications for Construction. Provide other required material, not specifically addressed in the Standard Specifications for Construction, in accordance with local utility company requirements and the *NEC*. Ensure the UG electrical service pedestal is in accordance with the following:

1. Suitable for mounting on a foundation as shown on the plans;
2. Fabricated from stainless steel;
3. Equipped with a 3- to 6-circuit, load center, 100 ampere service rated;
4. Neutral and ground lugs installed 15 inches from grade;
5. Customer door to have gasket on all four sides and equipped with a main door lock, Corbin no. 15481RS, Pelco (Type II) SM-1025 or equivalent Lock to be constructed of nonferrous or stainless materials, which operates with a Traffic Industry conventional #2 key, Corbin No. 1R6380 or Pelco (Type II) SM-0198-2 or equivalent. Ensure a minimum of two keys are included for the main door of each cabinet.
6. Ensure unmetered pedestal are no greater than: Width = 12.00 inches, Depth = 8.25 inches, Height = 32.00 inches; and
7. Ensure metered pedestal are no greater than: Width = 12.00 inches, Depth = 8.25 inches, Height = 52.00 inches.

c. Construction. Complete this work in accordance with sections 819 and 820 of the Standard Specifications for Construction, per the contract, and this special provision.

Contact the local power company and coordinate installation or removal, of underground electrical service power feed and meter and meter sockets as required, as indicated on the plans or as directed by the Engineer.

Where installation of new underground service, metered, is called for on the plans, install a new meter socket and provide bonding in compliance with MDOT, *NEC*, *National Electrical Safety Code (NESC)* and local utility company requirements. Use weatherproof LB's to enter and exit all meters, service disconnects, and controllers. Complete additional work required by the local utility company to make a complete and operating installation.

Where removal is called for on the plans, complete removal work in accordance with MDOT, *NEC*, *NESC*, and local utility company requirements.

d. Measurement and Payment. The completed work, as described, will be measured and paid for at the contract unit price using the following pay items:

Pay Item	Pay Unit
Pedestal, Underground Serv, (type)	Each
Pedestal, Underground Serv, Rem	Each

1. **Pedestal, Underground Serv, (type)** includes the work as described, including additional work required by the local utility company to make a complete and operating installation.

2. **Pedestal, Underground Serv, Rem** includes the work as described, including additional work required by the local utility company to remove a complete pedestal for underground electrical service.

MICHIGAN
DEPARTMENT OF TRANSPORTATION

SPECIAL PROVISION
FOR
MICRONIZED COPPER WATER BASED WOOD PRESERVATIVE SYSTEMS

STR:SCK

1 of 1

APPR:HLZ:POJ:04-13-20
FHWA:APPR:04-13-20

a. Description. Micronized copper water based wood preservative systems are an alternate to the preservative systems identified in section 912 of the Standard Specifications for Construction, except on wood posts used for signing. Micronized copper water based wood preservative systems are proprietary systems used to treat timber and lumber for resistance to insect attack, decay, and rot. Proprietary micronized copper based wood preservative systems are evaluated by the *International Code Council Evaluation Service, Inc (ICC-ES)*. This special provision covers the requirements for micronized copper azole (MCA) and micronized copper quaternary (MCQ).

b. Materials. *ICC-ES* requirements and specified commercial standards are incorporated herein by reference. Treated wood product reports issued by the *ICC-ES* as Evaluation Service Reports (ESRs) must be current as posted on the *ICC-ES* website <https://icc-es.org/> and in compliance with AC326. The preservative(s) must not contain arsenic. The treated wood product's report must allow for the wood species and end use that is required by the project specifications. The Contractor must provide test data certification for each lot, that the treated timber and lumber meets the retention requirements of the appropriate *AWPA* Use Category.

Condition and treat timber and lumber for above ground use to the minimum preservative retention corresponding to *AWPA* Use Category 4A (UC4A). Condition and treat timber and lumber for ground contact to the minimum preservative retention corresponding to *AWPA* Use Category 4B (UC4B).

Condition and treat all round posts, except northern white cedar, to the minimum preservative retention corresponding to *AWPA* Use Category 4B (UC4B).

Incorporation of timber and lumber treated to the preservative retention in *AWPA* Use Category 3B (UC3B) or less is not permitted. Timber and lumber placed in violation of this special provision is cause for removal and replacement at the contractor's expense. No pay adjustments will be allowed for incorporation of timber and lumber treated to UC3B preservative retention. Removal is required.

c. Construction. Use stainless steel fasteners or hot dipped galvanized fasteners in accordance with *ASTM A653/A653M*, batch or post-dipped process, with a minimum coating thickness of 1.85 oz of Zinc per square foot of surface area (G185). Do not mix fastener types. Do not use aluminum fasteners. Aluminum must not be in direct contact with treated wood. Non metallic spacers are to be used where contact with aluminum could occur.

d. Measurement and Payment. Payment is included in other items of work.

MICHIGAN
DEPARTMENT OF TRANSPORTATION

SPECIAL PROVISIONS
FOR
WOOD POLE REVISIONS

SIG:HJK

1 of 1

APPR:SCK:HLO:11-14-24
FHWA:APPR:11-21-24

Delete the third paragraph of subsection 918.11, on page 9-157 of the Standard Specifications for Construction, in its entirety and replace with the following.

Treat the full length of pressure treated poles with 4,5-dichlor-2-N-octyl-4-Isothiazolin-3-one (DCOI) in accordance with the AWPAs Processing and Treatment Standard for the Use Category System (UCS).

CITY OF KALAMAZOO

SPECIAL PROVISION

FOR

PAVT, REM, MODIFIED

Wightman/PTS

1 of 1

6/09/2025

a. Description. This work consists of removing HMA, concrete, bricks, sand and gravel interlayers, embedded rails, masonry, and any other common pavement material or combination of materials, regardless of thickness, reinforcement, and overlays.

b. Materials. None Specified

c. Construction. Remove pavement to an existing joint or sawed joint. Saw cut pavement full depth in a straight neat line as directed by the Engineer. Do not use a crane and ball pavement breaker. Do not disturb remaining pavement. Remove and dispose of existing HMA pavement, reinforced or non-reinforced concrete pavement, and other materials in accordance with subsection 204.03 of the Standard Specifications for Construction. From Sta. 63+38 to Sta. 83+00 Salvage any existing brick pavers encountered in the pavement section and stockpile at a centralized location onsite for pickup and removal by the City. Take care not to chip, break, or otherwise damage existing brick pavers during removal.

d. Measurement and Payment. The completed work, as described, will be measured and paid for at the contract unit price using the following pay item:

Pay Item	Pay Unit
Pavt, Rem, Modified.....	Square Yard

The limits of **Pavt, Rem, Modified** will be established as noted on the plans or at the discretion of the Engineer. The unit price includes all labor, equipment, and materials to salvage brick pavers and saw cut, remove, haul and dispose of the pavement, embedded rails, sand and gravel interlayers regardless of thickness.

CITY OF KALAMAZOO

SPECIAL PROVISION
FOR

EROSION CONTROL, INLET PROTECTION, FABRIC DROP, MODIFIED

Wightman/PTS

1 of 1

06/09/2025

a. Description. This work consists of furnishing and installing acceptable inlet protection devices (devices) listed in the *Soil Erosion and Sedimentation Control Manual* when the pay item Erosion Control, Inlet Protection, Fabric Drop, Modified is included in the contract.

b. Materials. The following devices are approved for use, or approved equal:

1. Siltsack Type B, Regular Flow with or without Curb Deflector, by ACF Environmental, Inc.
2. Inlet Pro Sediment Bag, Standard Flow, with or without foam deflector by Hanes Geo Components.
3. Dandy Curb Bag, Dandy Bag, Dandy Curb Sack, Dandy Sack, or Dandy Pop by Dandy Products, Inc.
4. Flexstorm Catch-It and Flexstorm Pure used with filter bag types FX, FX+, FXO, PC, PC+ or IL.

Fabric drops installed in curb inlets shall have a curb filter or deflector integrated into the product that fits across the curb back opening.

Ensure provided devices are sized appropriately for the drainage structures in which they will be installed.

c. Construction. Install, maintain and remove the devices in accordance with the manufacturer's guidelines. Remove material collected by the devices in accordance with the manufacturer's guidelines or as directed by the Engineer.

Dispose of collected material in accordance with subsection 205.03.P of the 2020 MDOT Standard Specifications for Construction. Those devices that are no longer needed and have been removed may be reused elsewhere on the project as approved by the Engineer.

d. Measurement and Payment. The completed work, as described, will be measured and paid for at the contract unit price using the following pay item:

Pay Item	Pay Unit
Erosion Control, Inlet Protection, Fabric Drop, Modified	Each

Erosion Control, Inlet Protection, Fabric Drop, Modified will be paid for as one each for each time the device listed herein is installed, maintained, and removed at a separate location within the project limits.

CITY OF KALAMAZOO
SPECIAL PROVISION
FOR

WATERBORNE PERMANENT PAVEMENT MARKINGS

Wightman/PTS

1 of 1

06/09/2025

a. Description. This work consists of providing all labor, material, and equipment necessary to prepare pavement surfaces and apply retroreflective permanent waterborne pavement markings. Ensure preparation of pavement surfaces and application of materials is in accordance with this special provision, the contract, 2020 MDOT Standard Specifications for Construction, Michigan Manual on Uniform Traffic Control Devices, manufacturer’s recommendations, and as directed by the Engineer.

b. Material. Provide material for waterborne pavement markings and glass beads in accordance with section 920 of the 2020 MDOT Standard specifications for Construction and from the Qualified Product List.

c. Construction. Install retroreflective permanent waterborne pavement markings of the type indicated at the specified locations or at the direction of the Engineer in accordance with section 811 of the 2020 MDOT Standard specifications for construction. Legends and symbols shall be of the appropriate shape and dimensions as provided for in the most recent edition of the Michigan Manual on Uniform Traffic Control Devices.

d. Measurement and Payment. The completed work as described will be measured and paid for at the contract price using the following pay items:

Pay Item	Pay Unit
Pavt Mrkg, Waterborne, ___ inch, (type), Modified.....	Foot
Pavt Mrkg, Waterborne, (legend/symbol), Modified.....	Each
Pavt Mrkg, Waterborne, ___ inch, Cross Hatching, (color), Modified.....	Foot
Pavt Mrkg, Waterborne, ___ inch, Dotted Thru Guide Line, (color), Modified.....	Foot
Pavt Mrkg, Waterborne, ___ inch, Solid Turning Guideline, (color), Modified.....	Foot

Removing curing compound, removing existing pavement marking, or recessing pavement markings required for the work in this special provision will be paid for separately under the respective pay items.

CITY OF KALAMAZOO

SPECIAL PROVISION

FOR

RELATIONS AND RESPONSIBILITY TO THE PUBLIC

COK

Page 1 of 1

6/9/2025

- a. Description.** The contractor shall notify the engineer when the first day of construction is planned no less than 10 business days prior to the start of the work. Following this correspondence, the City will issue a press release, media notice or other general form of notification to all the city's residents of the planned work. No work shall be performed prior to the issuance of this notice.

Additional notification shall be provided to the residents directly affected via door hanger notices no less than 72 hours before their street is planned to receive work. The contractor will provide preprinted door hanger material to carry the contractor's message. Message content must be approved by the engineer prior to printing and distribution. The responsibility for filling out the door hangers and distributing them will be the contractor's. Payment for this work will not be paid separately, but payment will be considered as having been included in the contract unit prices bid for other contract items. No work shall be performed prior to the distribution of these door hangers.

24 hours before every construction operation that will substantially affect a resident or business adjacent to the project site, (such as driveway closures, mailbox relocation, etc.) the contractor will notify residents or businesses affected. The contractor shall assist the City in coordination of work and mitigating impacts to the extent possible while maintaining construction schedules and ensuring project completion.

MICHIGAN
DEPARTMENT OF TRANSPORTATION

SPECIAL PROVISION
FOR
SLOPE RESTORATION, NON-FREEWAY

RSD:NJM

1 of 5

APPR:DMG:JJG:11-30-23

a. Description. This work consists of preparing all lawns and slopes on non-freeway projects designated for slope restoration on the plans or as directed by the Engineer and applying topsoil, fertilizer, seed, mulch with mulch anchor, mulch blanket, high velocity mulch blanket, permanent turf reinforcement mat (TRM), bonded fiber matrix (BFM), or modified mulch blanket to those areas. Ensure turf establishment is in accordance with section 816 and 917 of the Standard Specifications for Construction and Standard Plan R-100 Series, except as modified herein or otherwise directed by the Engineer.

b. Materials. The materials, application rates, and construction methods specified in sections 816 and 917 of the Standard Specifications for Construction apply unless modified by this special provision or otherwise directed by the Engineer. Furnish the following materials on this project:

1. Seeding mixture as called for on the plans.
2. Chemical fertilizer nutrient, Class ___.
3. Topsoil. The following percentages of furnished and salvaged topsoil are estimated for this project and provided for informational purposes only.

Topsoil Furnished: 30 percent

Topsoil Salvaged: 70 percent

4. Mulching material.
5. Permanent Turf Reinforcement Mat (TRM) for Slope Restoration, Non-Freeway, Type D, must be 100 percent synthetic and consist of 100 percent ultraviolet (UV) stabilized polyolefin fibers sewn between two layers of UV stabilized polypropylene netting with polyolefin thread. The TRM must meet the following "minimum average roll value" requirements:

<u>Property</u>	<u>Test Method</u>	<u>Requirement</u>
Mass/Unit Area	ASTM D6566	10 oz/syd
UV Stability @ 1000 hrs	ASTM D4355/D4355M	80 percent
Tensile Strength (MD)	ASTM D6818	165 lbs/ft

Acceptance. Supply a general certification for the permanent TRM from one of the following manufacturers or approved equal:

Recyclex TRM	American Excelsior Co., Arlington, TX	(800) 777-7645
P300 TRM	North American Green, Poseyville, IN	(800) 772-2040

Landlok 450 TRM	Propex, Inc., Chattanooga, TN	(800) 621-1273
Excel PP5-10 TRM	Western Excelsior, Evansville, IN	(866) 540-9810
Vmax P550 TRM	North American Green, Poseyville, IN	(800) 772-2040

6. Bonded Fiber Matrix (BFM) for use in Slope Restoration, Non-Freeway, Type E. Furnish a product from the list below or an approved equal.

Soil Guard	Mat Inc., Floodwood, MN	(888) 477-3028
HydroStraw BFM	HydroStraw, LLC, Rockford, WA	(800) 545-1755
HydraMax	North American Green, Poseyville, IN	(800) 772-2040
Bindex BFM	American Excelsior Co., Arlington, TX	(800) 777-7645
ProMatrix EFM	Profile Products LLC, Buffalo Grove, IN	(800) 508-8681

If multiple grades of the selected product are available, use the grade appropriate for the application as approved by the Engineer.

Approved equal BFMs must consist of long strand, virgin wood fibers (90 percent by weight) bound together by a pre-blended, high-strength polymer adhesive (10 percent by weight). The virgin wood fibers will be thermally refined from clean whole wood chips. Ensure the organic binders are a high-viscosity colloidal polysaccharide tackifier with activating agents to render the resulting matrix insoluble upon drying.

7. Modified Mulch Blanket. Where modified mulch blanket is required, furnish an excelsior mulch blanket free of chemical additives. Ensure the netting thread is 100 percent biodegradable and manufactured with non-plastic materials such as jute, sisal, or coir fiber. Degradable, photodegradable, UV-degradable, oxo-degradable, or oxo-biodegradable plastic netting including polypropylene, nylon, polyethylene, and polyester is not an acceptable alternative. All netting materials must have a loose weave design with movable junctions between the machine and cross-machine direction twines that move independently and reduce the potential for wildlife entanglement.

For Slope Restoration, Non-Freeway, Type F, furnish a single net modified mulch blanket from the list below or an approved equal.

Premier Straw Single Net FibreNet	American Excelsior Co.	(800) 777-7645
Curlex NetFree 100% Biodegradable	American Excelsior Co.	(800) 777-7645
ECS-1B Biodegradable Single Straw	East Coast Erosion Control	(800) 582-4005
S1000BD Single Net	Enviroscape ECM, Ltd.	(888) 550-1999
Excel SR-1 All Natural	Western Excelsior Corp.	(866) 540-9810
S75BN	Western Excelsior Corp.	(866) 540-9810

For Slope Restoration, Non-Freeway, Type G, furnish a double net modified mulch blanket from the list below or an approved equal.

Premier Straw Double Net FibreNet	American Excelsior Co.	(800) 777-7645
Curlex II FibreNet	American Excelsior Co.	(800) 777-7645
ECX-2B Double Net Biodegradable	East Coast Erosion Control	(800) 582-4005
S2000BD Double Net	Enviroscape ECM, Ltd.	(888) 550-1999
Excel R-2 All Natural	Western Excelsior Corp.	(866) 540-9810
Excel SS-2 All Natural	Western Excelsior Corp.	(866) 540-9810
S150BN	Western Excelsior Corp.	(866) 540-9810

c. Construction. Ensure construction methods are in accordance with subsection 816.03 of the Standard Specifications for Construction. Begin this work as soon as possible after final grading of the areas designated for slope restoration but no later than the maximum time frames specified in subsection 208.03 of the Standard Specifications for Construction. It may be necessary, as directed by the Engineer, to place materials by hand.

Shape, compact, and ensure all areas to be seeded are weed-free prior to placing topsoil. Place topsoil to the minimum depth as detailed herein and in accordance with the plans and standard specifications to meet proposed finished grade. If the area being restored requires more than the minimum depth of topsoil to meet finished grade, fill this additional depth using topsoil or, at the Contractor's option, embankment. Furnishing and placing this additional material is included in this item of work.

Ensure topsoil is weed and weed seed free and friable prior to placing seed. Remove any stones greater than 1/2-inch in diameter or other debris. Apply seed mixture and fertilizer to prepared soil surface. Incorporate seed into top 1/2-inch of topsoil.

Spread mulch at a rate of two tons per acre. If the Engineer allows dormant seeding spread mulch at a rate of 3 tons per acre. Place mulch anchoring over the mulch at a rate in accordance with subsection 816.03.F of the Standard Specifications for Construction. Place mulch blanket and high-velocity mulch blanket in accordance with subsection 816.03.G of the Standard Specifications for Construction and Standard Plan R-100 Series.

Install areas constructed with the TRM on prepared (seeded) grades as shown on the plans in accordance with the manufacturer's published installation guidelines. Anchor the top edge of the TRM in a minimum six-inch deep trench. Operation of equipment on the slope is prohibited after placement of the TRM. No credit for splices, overlaps, tucks, or wasted material will be made.

Mix the BFM and organic binders thoroughly at a rate of 40 pounds for each 100 gallons of water or as otherwise recommended by the manufacturer. Hydraulically apply the BFM slurry in successive layers, from two or more directions, to fully cover 100 percent of the soil surface. Ensure the minimum application rate is at least 3000 pounds of BFM for each acre or otherwise apply in accordance with the manufacturer's recommendations as appropriate depending on site conditions.

Do not apply BFM on saturated soils or immediately before, during, or after rainfall.

Install modified mulch blanket in accordance with the manufacturer's published guidelines and as directed by the Engineer.

If an area washes out after this work has been properly completed and approved by the Engineer, make the required corrections to prevent future washouts and replace the topsoil, fertilizer, seed, and mulch treatment. This replacement will be paid for as additional work using the applicable pay items.

If an area washes out for reasons attributable to the Contractor's activity or failure to take proper precautions, replacement will be at no cost to the contract.

The Engineer will inspect the seeded turf to ensure it is well-established, in a vigorous growing condition, and contains the species called for in the seeding mixture.

If the seeded turf is not well-established at the end of the first growing season, the Contractor is responsible to re-seed until the turf is well established and approved by the Engineer at no cost to the contract.

Provide weed control, if weeds are determined by the Engineer to cover more than 10 percent of the total area of slope restoration, in accordance with subsection 816.03.I of the Standard Specifications for Construction. Weed control will be at no additional cost to the contract.

d. Measurement and Payment. The completed work, as described, will be measured and paid for at the contract unit price using the following pay items:

Pay Item	Pay Unit
Slope Restoration, Non-Freeway, Type __	Square Yard

1. Place **Slope Restoration, Non-Freeway, Type A** in all areas not described in the other types of slope restoration and will be measured by area in square yards in place. **Slope Restoration, Non-Freeway, Type A** includes installing Topsoil Surface, Furn, LM or Topsoil Surface, Salv, 4 inch; Fertilizer, Chemical Nutrient, Class A; seeding mixture; Mulch; and Mulch Anchoring.

2. Place **Slope Restoration, Non-Freeway, Type B** parallel (8 feet minimum) to the edge of the roadway in areas that have a 1 on 3 slope or less, in any ditch with a grade less than 1.5 percent, as shown on the plans, or as directed by the Engineer. **Slope Restoration, Non-Freeway, Type B** will be measured by area in square yards in place. **Slope Restoration, Non-Freeway, Type B** includes installing Topsoil Surface, Furn, LM or Topsoil Surface, Salv, 4 inch; Fertilizer, Chemical Nutrient, Class A; seeding mixture; and Mulch Blanket.

3. Place **Slope Restoration, Non-Freeway, Type C** in areas that have a 1 on 2 slope, any ditch with a grade of 1.5 percent to 3 percent as shown on the plans, or as directed by the Engineer. **Slope Restoration, Non-Freeway, Type C** will be measured by area in square yards in place. **Slope Restoration, Non-Freeway, Type C** includes installing Topsoil Surface, Furn, LM or Topsoil Surface, Salv, 4 inch; Fertilizer, Chemical Nutrient, Class A; seeding mixture; and Mulch Blanket, High Velocity.

4. Place **Slope Restoration, Non-Freeway, Type D** in areas that have a slope steeper than 1 on 2, any ditch with a grade steeper than 3 percent as shown on the plans, or as directed by the Engineer. **Slope Restoration, Non-Freeway, Type D** will be measured by area in square yards in place. **Slope Restoration, Non-Freeway, Type D** includes installing Topsoil Surface, Furn, LM or Topsoil Surface, Salv, 4 inch; Fertilizer, Chemical Nutrient, Class A; seeding mixture; and Turf Reinforcement Mat.

5. Place **Slope Restoration, Non-Freeway, Type E** as shown on the plans, or as directed by the Engineer and measured by area in square yards in place. **Slope Restoration, Non-Freeway, Type E** includes installing Topsoil Surface, Furn, LM or Topsoil Surface, Salv, 4 inch; Fertilizer, Chemical Nutrient, Class A; seeding mixture; and Bonded Fiber Matrix.

6. Place **Slope Restoration, Non-Freeway, Type F** parallel (8 feet minimum) to the edge of the roadway, in areas that have a 1 on 3 slope or less, and in any ditch with a grade

less than 1.5 percent. **Slope Restoration, Non-Freeway, Type F** includes installing Topsoil Surface, Furn, LM or Topsoil Surface, Salv, 4 inch; Fertilizer, Chemical Nutrient, Class A; seeding mixture; and single net modified Mulch Blanket.

7. Place **Slope Restoration, Non-Freeway, Type G** in areas that have a 1 on 2 slope and in any ditch with a grade of 1.5 percent to 3 percent. **Slope Restoration, Non-Freeway, Type G** includes installing Topsoil Surface, Furn, LM or Topsoil Surface, Salv, 4 inch; Fertilizer, Chemical Nutrient, Class A; seeding mixture; and double net modified Mulch Blanket.