



Department of Management Services
Purchasing Division
241 West South Street
Kalamazoo, MI 49007-4796
Phone: 269.337.8020
www.kalamazoo-city.org
cokpurchasing@kalamazoo-city.org

INVITATION FOR BIDS (IFB)

The City of Kalamazoo, Michigan is soliciting sealed bids for:

Project Name: DWSRF Non-Copper Service Line Replacement FY 26

Bid Reference #: 91244-051.0

IFB ISSUE DATE: April 13, 2026

BID DUE/OPENING DATE: May 12, 2026, at 3:00 p.m. Local Time
Electronic Bids Will Not Be Accepted.

MAILING ADDRESS & INSTRUCTIONS

Mail to:

Purchasing Division
241 W. South Street
Kalamazoo, MI 49007

Questions about this IFB should be directed to:

Department Contact: Anna Crandall, PE, Assistant
City Engineer at crandalla@kalamazoo-city.org

Include on the Envelope the Project Name and Bid Reference Number. All Envelopes Must Be Sealed.

You are invited to submit a bid for this project. Specifications, terms, conditions, and instructions for submitting bids are contained herein. This Invitation for Bids with all pages, documents and attachments contained herein, or subsequently added to and made a part hereof, submitted as a fully and properly executed bid shall constitute the contract between the City and the successful bidder when approved and accepted on behalf of the City by an authorized official or agent of the City. Please review the bid document as soon as possible and note the **DEADLINE FOR QUESTIONS** in the Instructions to Bidders.

All bidders shall complete and return the Bid and Award page(s) and submit all information requested herein in order for a bid to be responsive. The bid document shall be returned in its entirety, in a properly identified and sealed envelope to the Purchasing Division at the above address. **BIDS MUST BE RECEIVED BEFORE THE DUE DATE - LATE BIDS WILL NOT BE CONSIDERED.** The City reserves the right to postpone the bid opening for its own convenience.

TABLE OF CONTENTS

<u>SECTION</u>	<u>PAGE #</u>	<u>APPENDICES</u>
	Statement of No Bid	Appendix A
I	Instructions to Bidders	Appendix B
II	Bid & Award Pages	EGLE Forms &
III	Insurance Requirements	Prevailing Wages
IV	Special Requirements	Specifications & Plans
V	General Provisions	
VI	Terms & Conditions	

STATEMENT OF NO BID

NOTE: If you DO NOT intend to bid on this commodity or service, please complete and return this form immediately. Your response will assist us in evaluating all responses for this important project and to improve our bid solicitation process.

The Purchasing Division of the City of Kalamazoo wishes to keep its bidders list file up to date. If, for any reason you cannot supply the commodity/service noted in this bid solicitation, this form must be completed and returned to remain on the particular bid list for future projects of this type.

If you do not respond to this inquiry within the time set for the bid opening date and time noted, we will assume that you can no longer supply this commodity/service, and your name will be removed from this bid list.

- _____ Specifications too "tight", i.e. geared toward one brand or manufacturer only (explain below).
- _____ Specifications are unclear (explain below).
- _____ We are unable to meet specifications.
- _____ Insufficient time to respond to the Invitation for Bid.
- _____ Our schedule would not permit us to perform.
- _____ We are unable to meet bond requirements.
- _____ We are unable to meet insurance requirements.
- _____ We do not offer this product or service.
- _____ Remove us from your bidders list for this commodity or service.
- _____ Other (specify below).

REMARKS: _____

SIGNED: _____ NAME: _____
(Type or Print)

TITLE: _____ DATE: _____

FIRM NAME: _____
(if any)

ADDRESS: _____
(Street address) (City) (State) (Zip)

PHONE: _____

EMAIL: _____

SECTION I
INSTRUCTIONS TO BIDDERS

1. **EXAMINATION OF BID DOCUMENT**-Before submitting a bid, bidders shall carefully examine the specifications and shall fully inform themselves as to all existing conditions and limitations. The bidder shall indicate in the bid the sum to cover the cost of all items included on the bid form.
2. **PREPARATION OF BID**-The bid shall be legibly prepared in ink or typed. If a unit price or extension already entered by the bidder on the Bid and Award form is to be altered, it shall be crossed out and the new unit price or extension entered above or below and initialed by the bidder with ink. The bid shall be legally signed, and the complete address of the bidder given thereon.

All bids shall be tightly sealed in an envelope plainly marked SEALED BID and identified by project name, bid opening date and time. Bids opened by mistake, due to improper identification, will be so documented and resealed. The Purchasing Division will maintain and guarantee confidentiality of the contents until the specified opening date and time. Bids submitted by electronically will not be accepted.

3. **EXPLANATION TO BIDDERS**-Any binding explanation desired by a bidder regarding the meaning or interpretation of the Invitation for Bid (IFB) and attachments must be requested in writing, **at least 5 business days before the bid opening (May 4, 2026, by 10:00 a.m.)** so a reply may reach all prospective bidders before the submission of bids. Any information given to a prospective bidder concerning the IFB will be furnished to all prospective bidders as an amendment or addendum to the IFB if such information would be prejudicial to uninformed bidders. Receipt of amendments or addenda by a bidder must be acknowledged in the bid by attachment, or by letter received before the time set for opening of bids. Oral explanation or instructions given prior to the opening will not be binding.
4. **CASH DISCOUNTS**-Discount offered for payment of less than thirty (30) days will not be considered in evaluating bids for award. Offered discounts of less than thirty (30) days will be taken if payment is made within the discount period, even though not considered in evaluation of the bid.
5. **WITHDRAWAL OF BIDS**-Bids may be withdrawn in person by a bidder or authorized representative, provided their identity is made known and a receipt is signed for the bid, but only if the withdrawal is made prior to the exact time set for receipt of bid. No bid may be withdrawn for at least ninety (90) days after bid opening.
6. **ALTERNATE BIDS**-bidders are cautioned that any alternate bid, unless specifically requested or any changes, insertions or omissions to the terms and conditions, specifications or any other requirement of this IFB may be considered non-responsive, and at the option of the City, result in rejection of the alternate bid.
7. **LATE BIDS**-Any bid received at the office designated herein after the exact time specified for receipt will not be considered. (Note: The City reserves the right to consider bids that have been determined by the City to be received late due to mishandling by the City after receipt of the bid and no award has been made.)
8. **UNIT PRICES**-If there is a discrepancy between unit prices and their extension, unit prices shall prevail.
9. **BID SUBMITTAL**- Bidders can submit sealed bids in one of the following ways:
 - 9.1. **Mail your bid**, to be received before the bid due date and time indicated in the bid document, to the City of Kalamazoo at the following address:

City of Kalamazoo
Purchasing Division
241 West South Street
Kalamazoo, MI 49007

- 9.2. **Deliver your bid to City Hall In-Person** before the bid due date and time indicated in the bid document.
- 9.3. **Deliver your bid to the Treasurer’s Office Payment Drop Box** located in the northwest corner of City Hall (see photos below) before the bid due date and time indicated in the bid document.



1. Open drop box located at City Hall.



2. Insert SEALED BID here.



- 10. **BID TABULATIONS-** The Purchasing Division makes an effort to post bid tabulations to the City of Kalamazoo website within 24 hours after the bid opening date and time at: <https://www.kalamazoocity.org/bidopportunities>. However, in certain cases the posting of the bid tabulation may extend beyond the 24-hour window.

SECTION II
BID AND AWARD

The undersigned having become thoroughly familiar with all of the bid/contract documents incorporated herein, the project site and the location conditions affecting the work, hereby proposes to perform everything required to be performed in strict conformity with the requirements of these documents, and to provide and furnish all the equipment, labor and materials necessary to complete in a professional manner the furnishing and installing of all of the following, meeting or exceeding the specifications as set forth herein for the prices as stated below.

DWSRF NON-COPPER SERVICE LINE REPLACEMENT FY 26

Item	Description	Qty	Unit	Unit Price	Extended Price
1	Mobilization	1	LS		
2	Water Service Potholing	850	EA		
3	Water Service - Long	450	EA		
4	Water Service - Short	550	EA		
5	Water Service - Yard	1100	EA		
6	Water Service - Private	170	EA		
7	Ford Box	170	EA		
8	2" Service	50	EA		
9	Copper Tubing, Additional Length, 2"	200	FT		
10	2" Meter Vault	5	EA		
11	Abandon Blind	250	EA		
12	Plumber	4,000	HR		
13	Sidewalk Remove & Replace	50,000	SF		
14	Curb Remove & Replace	10,000	LF		
15	Road or Driveway Remove & Replace COK (Exhibit A)	12,000	SY		
16	Road or Driveway Remove & Replace COK Winter (Exhibit B)	5,000	SY		
17	HMA Driveway Remove & Replace	500	SY		
18	Stamp Concrete	500	SY		
19	Traffic Control	1	LS		
20	HMA 13A	60	TON		
21	HMA, MDOT 4E	1,500	TON		
22	HMA, MDOT 5E	1,900	TON		
23	Milling 1.5"	7,000	SY		
24	Gravel Driveway, 8" 22A	100	SY		
25	Water Filter	1,300	EA		
26	Curb Valve	10	EA		
27	Curb Box	10	EA		
28	Miscellaneous Repair Allowance	1	LS	\$10,000.00	\$10,000.00
TOTAL BID AMOUNT					\$

Bidder shall provide all the information as requested herein with their bid. **Failure to do so and/or failure to provide post-bid requested information may be cause for rejecting the bid as non-responsive.**

Work shall start within 10 days of receipt of Notice to Proceed, but not prior to the EGLE Order of Approval expected on August 6, 2026. Contractor shall have materials on hand to be prepared to start service line replacements immediately. Contractor shall complete below table of materials on-hand for the project. Contractor shall also provide estimated dates for arrival of additional materials. Contractor shall have service line work completed by **June 30, 2028**, with final completion by **November 1, 2028**.

TABLE OF ON-HAND MATERIALS FOR PROJECT

Item Description	Unit	Brand	Quantity On-Hand	Estimated Delivery Date of Balance
Corp 1 inch x 1 1/4	EA			
Curb Stop 3/4 inch FCxFC	EA			
Curb Stop 1 1/4 inch FCxFC	EA			
Curb Stop 1 1/4 inch FCxFIP	EA			
0.75" x 1.25" Bushing	EA			
0.75" MIPxFC	EA			
Curb Stop 2 inch FIPxFIP	EA			
2" MIP x FC	EA			
5/8 inch Meter Horn	EA			
1 1/4 inch Meter Horn	EA			
3/4 inch x 5/8 inch Angle Valve (FCxMN)	EA			
3/4 inch x 5/8 inch Straight Valve (FCxMN)	EA			
1 1/4 inch x 1 inch Angle Valve (FCxMN)	EA			
1 1/4 inch x 1 inch Straight Valve (FCxMN)	EA			
Meter Connector - 3/4 inch MIP x 5/8 inch MC	EA			
Meter Connector - 1" MIP x 1" MC	EA			
3/4 inch ball valve	EA			
1 inch ball valve	EA			
3/4 inch Copper	FT			
1 1/4 inch Copper	FT			

Bidder/Contractor has examined and carefully studied the bidding documents and attachments, and acknowledges receipt of the following addenda:

Addendum No: _____

Dated: _____

By my signature below, I certify that the firm bidding on this contract, when making hiring decisions, does not use a past criminal conviction as a bar to or preclude a person with a criminal conviction from being considered for employment with the bidding firm unless otherwise precluded by federal or state law. I further certify that I have read and agree to be bound by the provisions of the City’s Non-Discrimination Clause found in Appendix A as updated by City Ordinance 1856.

Signed: _____ Name: _____

Title: _____

CITY OF KALAMAZOO EX-OFFENDER POLICY CHECKLIST

As part of the City's commitment to reducing unacceptable poverty, encouraging rehabilitation, reducing recidivism, and strengthening families in Kalamazoo, the City has updated its Purchasing Policy to ensure that firms with whom the City does business share in this commitment by utilizing hiring practices that do not unfairly deny people with arrest and conviction records gainful employment. *(Important: This requirement also extends to any subcontractors the bidder intends to use to fulfill the contract for goods or services being sought from the City.)*

Part I: Proof that the bidder does not inquire about an individual's past arrest or criminal history on the bidder's employment application form

- Attach a copy of the current application for employment being used by the bidder

Part II: Certification that the bidder does not use an individual's past arrest or criminal history to unlawfully discriminate against them by checking *one or more* of the following:

- That pursuant to federal or state law bidder is precluded from hiring persons with certain criminal records from holding particular positions or engaging in certain occupations by providing a cite to the applicable statute or regulation; if checking this box, provide a citation to the applicable statute or rule upon which the bidder is relying: _____
- That bidder conducts criminal history background checks only as necessary, and only after making a conditional offer of employment; that any withdrawal of an offer of employment to an individual because of a past criminal history is job-related and consistent with business necessity after the individual has been provided an individualized assessment opportunity to review and challenge or supplement the history of past criminal conduct being relied upon by the bidder;
- That the use by bidder of criminal history background checks complies with the U.S. Equal Employment Opportunity Commission's Enforcement Guidance on the Consideration of Arrest and Conviction Records in Employment Decisions and that the bidder has not had a determination rendered against it in past 7 years that it discriminated against a person through the use of an individual's arrest or criminal history

I CERTIFY THAT THE ABOVE STATEMENTS ARE TRUE.

Date

Signature

Printed Name

Position

REFERENCE QUESTIONNAIRE

Please answer the following questions completely.

1. Firm name: _____
2. Established: Year _____ Number of Employees: _____
3. Type of organization:
 - a. Individual: _____
 - b. Partnership: _____
 - c. Corporation: _____
 - d. Other: _____
4. Former firm name(s) if any, and year(s) in business:

5. Include at least 5 references of contracts for similar work performed over the last five (5) years. The City of Kalamazoo Water System is a Type 1 Public Water Supply. For the protection of public health, the City requires that any contractor performing work on the water system is qualified with experience working on other Type 1 Public Water Supply Systems with projects of similar scope to this bid.
Include: owner, contact person and phone number and description of work performed.
 - 5.1 Company Name: _____
Address: _____
Phone: _____
Contact: _____
Type of work or contract: _____
 - 5.2 Company Name: _____
Address: _____
Phone: _____
Contact: _____
Type of work or contract: _____
 - 5.3 Company Name: _____
Address: _____
Phone: _____
Contact: _____
Type of work or contract: _____

REFERENCE QUESTIONNAIRE
Continued

5.4 Company Name: _____
Address: _____
Phone: _____
Contact: _____
Type of work or contract: _____

5.5 Company Name: _____
Address: _____
Phone: _____
Contact: _____
Type of work or contract: _____

I hereby certify that all the information provided is true and answered to the best of my ability.

Signed: _____ Name: _____
(type or print)

Title: _____ Date: _____

I hereby state that all the information I have provided is true, accurate and complete. I hereby state that I have the authority to submit this bid which will become a binding contract if accepted by the City of Kalamazoo. I hereby state that I have not communicated with nor otherwise colluded with any other bidder, nor have I made any agreement with nor offered/accepted anything of value to/from an official or employee of the City of Kalamazoo that would tend to destroy or hinder free competition.

The firm's identification information provided will be used by the City for purchase orders, payment, and other contractual purposes. If the contractual relationship is with, or the payment made to, another firm please provide a complete explanation on your letterhead and attach to your bid. Please provide for accounts payable purposes:

Tax Identification Number (Federal ID): _____

Remittance Address: _____

Financial Contact Name: _____ Financial Contact Phone Number: _____

Financial Contact Email Address: _____

I hereby state that I have read, understand, and agree to be bound by all terms and conditions of this bid document.

SIGNED: _____ NAME: _____
(Type or Print)

TITLE: _____ DATE: _____

FIRM NAME: _____
(if any)

ADDRESS: _____
(Street address) (City) (State) (Zip)

PHONE: _____

EMAIL ADDRESS: _____

FOR CITY USE ONLY - DO NOT WRITE BELOW

**SECTION III
CITY OF KALAMAZOO
INDEMNITY AND INSURANCE**

Contractor, or any of their subcontractors, shall not commence work under this contract until they have obtained the insurance required under this paragraph, and shall keep such insurance in force during the entire life of this contract. All coverage shall be with insurance companies licensed and admitted doing business in the State of Michigan and acceptable to the City of Kalamazoo within ten (10) days of the Notice of Award. The requirements below should not be interpreted to limit the liability of the Contractor. All deductibles and SIRs are the responsibility of the Contractor.

The Contractor shall procure and maintain the following insurance coverage:

Workers' Compensation Insurance including Employers' Liability Coverage, in accordance with all applicable statutes of the State of Michigan.

Commercial General Liability Insurance on an "Occurrence Basis" with limits of liability not less than \$1,000,000 per occurrence and aggregate. Coverage shall include the following extensions: (A) Contractual Liability; (B) Products and Completed Operations; (C) Independent Contractors Coverage; (D) Broad Form General Liability Extensions or equivalent, if not already included and (E) XCU coverage if the nature of the contract requires XC or U work.

Automobile Liability in accordance with all applicable statutes of the State of Michigan, with limits of liability not less than \$1,000,000 per occurrence, combined single limit for Bodily Injury, and Property Damage. Coverage shall include all owned vehicles, all non-owned vehicles, and all hired vehicles.

Additional Insured: Commercial General Liability and Automobile Liability, as described above, shall include an endorsement stating that the following shall be *Additional Insureds*: The City of Kalamazoo, all elected and appointed officials, all employees and volunteers, all boards, commissions, and/or authorities and board members, including employees and volunteers thereof. It is understood and agreed that by naming the City of Kalamazoo as additional insured, coverage afforded is considered to be primary and any other insurance the City of Kalamazoo may have in effect shall be considered secondary and/or excess.

To the fullest extent permitted by law the Contractor agrees to pay on behalf of, indemnify, and hold harmless the City of Kalamazoo, its elected and appointed officials, and employees against any claims, demands, suits, or loss, including all costs connected therewith, and for any damages which may be asserted, claimed, or recovered against or from the City of Kalamazoo, by reason of personal injury, including bodily injury or death and/or property damage, including loss of use thereof, caused in whole or part by any negligent act or omission by the Contractor, its employees, agents, or officers which arises out of, or is in any way connected or associated with, this contract.

Cancellation Notice: All policies, as described above, shall include an endorsement stating that it is understood and agreed that thirty (30) days, or ten (10) days for non-payment of premium, Advance Written Notice of Cancellation, Non-Renewal, Reduction, and/or Material Change shall be sent to: City of Kalamazoo, Purchasing Division, 241 W. South Street, Kalamazoo, MI 49007.

Proof of Insurance Coverage: The Contractor shall provide the City of Kalamazoo at the time that the contracts are returned by him/her for execution, or within 10 days of Notice of Award, whichever is earlier, a Certificate of Insurance as well as the required endorsements. In lieu of required endorsements, if applicable, a copy of the policy sections where coverage is provided for additional insured and cancellation notice would be acceptable. Copies or certified copies of all policies mentioned above shall be furnished, if so requested.

INDEMNITY AND INSURANCE
Continued

If any of the above coverages expire during the term of this contract, the Contractor shall deliver renewal certificates and/or policies to City of Kalamazoo at least ten (10) days prior to the expiration date.

Scope of Coverage: The above requirements and conditions shall not be interpreted to limit the liability of the Contractor under this Contract but shall be interpreted to provide the greatest benefit to the City and its officers and employees. The above listed coverages shall protect the Contractor, its employees, agents, representatives, and subcontractors against claims arising out of the work performed. It shall be the Contractor's responsibility to provide similar insurance for each subcontractor or to provide evidence that each subcontractor carries such insurance in like amount prior to the time such subcontractor proceeds to perform under the contract.

**SECTION IV
SPECIAL REQUIREMENTS**

1. BID BOND/GUARANTEE

The bid must be accompanied by a bid bond which shall not be less than five (5%) percent of the total amount of the bid. No bid will be considered unless it is accompanied by the required guarantee. The bid guarantee shall ensure the execution of the bid and award, and the furnishing of a performance bond and a labor and material bond (A and B below) by the successful bidder. (Contractors Note: A cashier's or certified check in lieu of a bid bond is **NOT** acceptable.)

A. PERFORMANCE BOND

A performance bond shall be furnished in the full amount of the contract ensuring the City of faithful performance of all the provisions of the contract, and the satisfactory performance of any equipment required hereunder. The bond shall also ensure the City against defective workmanship and/or materials.

B. LABOR AND MATERIAL (PAYMENT) BOND

A labor and material (payment) bond shall be furnished for the period covered by the contract, in the full amount of the contract for the protection of labor and material suppliers and sub-contractors.

Bonds shall be secured by a guaranty or a surety company listed in the latest issue of the U.S. Treasury, circular 570, and licensed to do business in the State of Michigan, and written in favor of the City of Kalamazoo. The amount of such bonds shall be within the maximum amount specified for such company in said circular 570. The bonds shall be accompanied by a power of attorney showing authority of the bonding agent to sign such bonds on behalf of the guaranty or surety company. The cost of the bonds shall be borne by the Contractor.

Failure of the Contractor to supply the required bonds within ten (10) days after Notice of Award, or within such extended period as the Purchasing Agent may agree to, shall constitute a default and the City of Kalamazoo may either award this contract to the next lowest bidder or re-advertise for bids and may charge against the Contractor for the difference between the amount of the bid and the amount for which a contract for the work is subsequently executed, irrespective of whether the amount thus due exceeds the amount of the bid bond. If a more favorable bid is received by re-advertising, the defaulting bidder shall have no claim against the City of Kalamazoo for a refund.

2. WAIVERS OF LIEN

Upon completion of all work and request for final payment, the Contractor shall furnish a 100% waiver of lien from each supplier and sub-contractor covering all items of the work. Failure to supply waivers of lien for the entire job upon completion and final payment request will be considered grounds for withholding final payment.

3. SUBCONTRACTORS

- A. Contractors shall state on the Bid and Award page any and all subcontractors to be associated with their bid, including the type of work to be performed. Any and all subcontractors shall be bound by all of the terms, conditions and requirements of the contract; however, the prime contractor shall be responsible for the performance of the total work requirements.
- B. The Contractor shall cooperate with the City of Kalamazoo in meeting its commitments and goals with regard to maximum utilization of minority and women business enterprise and shall use its best efforts to ensure that minority and women business enterprises have maximum practicable opportunity to compete for subcontract work under this agreement.

4. PREVAILING WAGES

The successful bidder will be required to comply with Section 2-125 of the Code of Ordinances of the City of Kalamazoo regarding prevailing wages and Appendix B attached, incorporated herein by reference. Special note: This provision applies only to projects in excess of \$100,000 for City (\$2,000 federal) funded projects.

The City's requirements as it relates to prevailing wages includes a meeting with the City's Purchasing Division **prior** to work and payroll and work monitoring during the duration of the contract. Please contact Purchasing at (269) 337-8020 if you have any questions regarding Davis-Bacon provisions.

**SECTION V
GENERAL PROVISIONS**

1. INTENT

It is the intent of these plans and specifications to provide for a contractor who shall provide all labor, materials, tools, and equipment necessary to perform in a professional manner for **DWSRF Non-Copper Service Line Replacement FY 26** as described in the specifications and bid document.

2. SCOPE OF WORK

This contract includes but is not limited to: All work as shown on the drawings and described in the specifications for the replacement of water services that are not copper to copper, and associated work. This project includes checking, replacing, or abandoning water services at approximately 1300 locations.

3. QUANTITIES

The quantities shown or indicated on the specifications and plans are only estimated. Payment will be made based upon unit pricing of quantities installed.

4. UNIT PRICING

The unit price, including its pro-rata share of overhead, multiplied by the quantity shown shall represent the total bid and shall be held firm for the life of this contract. Any bid not conforming to this requirement may be rejected as non-responsive.

5. INSPECTION OF WORK

The City may maintain inspectors on the job who shall at all times have access to work.

6. INSPECTION OF SITE

Each bidder shall visit the site of the proposed work and fully acquaint himself/herself with the existing conditions relating to construction and labor and shall fully inform himself/herself as to the facilities involved and the difficulties and restrictions attending the performance of this contract. The bidder shall thoroughly examine and become familiar with the drawings, specifications and all other bid/contract documents. The Contractor, by the execution of this contract, shall in no way be relieved of any obligation under it due to his/her failure to receive or examine any form or legal instrument, or to visit the site and acquaint himself/herself with the conditions there existing. No allowance shall be made subsequently in this connection in behalf of the Contractor for any negligence of his/her part. For inspection call the Public Services Department, Water Resources Division.

7. INSPECTION AND TESTING

The Contractor shall give the Project Manager timely notice of readiness of the work for all required inspections, tests or approvals, and shall cooperate with inspections and testing personnel to facilitate required inspections or tests. The City will provide for materials and construction testing including but not limited to compaction of subbase and backfill material, concrete testing and asphalt testing. The cost of said testing shall be borne by the City. Verification that testing required by the contract has been completed on one phase of the project prior to proceeding to the next phase is the responsibility of the Contractor. In the event that the project has proceeded without required testing, the Contractor shall insure that the required testing is obtained retroactively and shall provide access for testing as necessary at his/her sole expense.

8. MATERIALS INSPECTION AND RESPONSIBILITY

- 8.1 The Project Manager shall have the right to inspect any materials to be used in carrying out the terms of the contract.
- 8.2 The City does not assume any responsibility for the contracted quality and standard of all materials, equipment, components or completed work furnished under this contract.
- 8.3 Any materials, equipment, components or completed work which does not comply with contract specifications, MDOT, or State codes may be rejected by the City, and shall be replaced by the Contractor at no cost to the City.
- 8.4 Any materials, equipment or components rejected shall be removed within a reasonable period of time from the premises of the City at the entire expense of the Contractor after notice has been given by the City to the Contractor that such materials, equipment or components have been rejected.

9. LAYING OUT WORK

Before submitting a bid the Contractor shall verify all measurements and shall be responsible for the correctness of same. No extra charge or compensation will be allowed on account of differences between actual dimensions and the measurements indicated on the drawings. Any difference that may be found shall be submitted to the City Engineer for consideration before proceeding. The City Engineer will provide staking for the project.

10. SUPERVISION

The Contractor shall employ an experienced superintendent or foreperson on the job at all times.

11. TEMPORARY UTILITIES

- 11.1 Temporary or construction water will NOT be available on the sites. The Contractor must provide for drinking water.
- 11.2 Temporary toilets: To be supplied by the Contractor as may be necessary.

12. SITE SECURITY

The Contractor shall be responsible for job site security of all materials and tools provided by him/her and no claim for loss or damage will be considered by the City.

13. TARDINESS

Construction delays resulting from tardiness on the part of the Contractor will be reviewed by the City in the event of any request for contract extension by the Contractor.

14. PROGRESS SCHEDULE

- 14.1 Work shall start immediately after receipt of Notice to Proceed, unless otherwise agreed to by the Project Manager.
- 14.2 **Project shall have completion of service line work by June 30, 2028, and a final completion date of November 1, 2028.**
- 14.3 Work of a similar nature may be added to this contract if agreed to by the City and the Contractor. In the event that work is added, the progress schedule for the work will remain unchanged. Any contract time added for additional work will be applied to that additional work only and cannot be added to items in the original contract. Any work done on the items in the original contract past the number of working days stated herein will be subject to liquidated damages regardless of any work that may be added at a later date.

PROGRESS SCHEDULE (Cont.)

- 14.4 The Contractor will be required to meet with the Public Services representatives to work out detailed progress schedule. The schedule for this meeting will be within two weeks after contract award has been made. **The Contractor shall submit a schedule that details the order of service replacements, street by street, with tentative timeline for each street.** This schedule shall be submitted prior to work beginning.
- 14.5 The named sub-contractor(s) for all items shall also be present at the scheduled meeting and they will be required to sign the Progress Schedule to indicate their approval of the scheduled dates of work set forth in the Progress Schedule.
- 14.6 The Progress Schedule shall include, as a minimum, the starting and completion dates for major items, and where specified in the bid document the date the project is to be opened to traffic as well as the final project completion date specified in the bid documents. The Progress Schedule shall be coordinated with all aspects of the work occurring at the site.
- 14.7 Failure on the part of the Contractor to carry out the provisions of the Progress Schedule as established may be considered sufficient cause to prevent bidding future projects until a satisfactory rate of progress is again established.
- 14.8 The starting date and the contract time to the completion date for this project may be adjusted by Public Services without imposing liquidated damages upon the receipt of satisfactory documented evidence that unforeseen delayed delivery of critical materials will prevent the orderly prosecution the work.
- 14.9 Section 501.03.I.2, Seasonal Limitations, is amended as follows: Seasonal limits for placing HMA mixtures in the City of Kalamazoo will be April 15 through November 15. No HMA paving will be allowed outside of these dates unless approved by the Engineer.

15. CONSTRUCTION SCHEDULE AND COORDINATION

- 15.1 The Contractor shall supply the City with an agreeable construction schedule before commencing work on this contract. This schedule shall detail beginning and completion dates for each major component of the project.
- 15.2 The Contractor shall coordinate and cooperate with all other contractors who may be working on the site in order to allow for the orderly progress of work being done.
- 15.3 The Contractor is required to keep the Project Manager fully informed of any proposed work which will tend to interfere with the existing operations at the site.
- 15.4 The Contractor shall schedule all work to accommodate the City's schedule. In the event Contractor's schedule falls on weekends, nights or overtime work is required, no additional compensation will be allowed. All work shall be part of this contract without regard to when it is done.

16. CONTRACTOR COORDINATION

- 16.1 The Contractor shall make every effort to coordinate every aspect of his work with that of other contractors on the site to assure an efficiently managed and proper installation.
- 16.2 Consideration shall be given to timing of construction, maintaining adequate construction access, and construction staging. Any costs associated with this coordination shall be included in the contract.

17. **COORDINATING CLAUSE**

The Contractor's attention is called to Article 104.08 of the 2012 MDOT Standard Specifications for Construction entitled "Cooperation by Contractor" and the project specifications contained within this contract.

18. **ADDITIONS**

18.1 Any modification to the contract shall be subject to prior approval by the Purchasing Agent. City Commission approval may also be required.

18.2 Prices for additional work required are not requested in the itemized listing contained herein for the base project. Should additional work be authorized, compensation shall be made on the basis of price or prices to be mutually agreed upon. Such additional work shall not begin until a Change Order has been approved.

19. **MAINTAINING TRAFFIC**

19.1 This work shall be in accordance with the requirements of Section 812 of the 2012 MDOT Standard Specifications for Construction and as specified herein. The Contractor is advised that the current Michigan Manual of Uniform Traffic Control Devices is hereby established as governing all work in connection with traffic control devices, barricade lighting, etc. required on this project.

19.2 The Contractor shall furnish, erect, maintain and, upon completion of the work, remove all traffic control devices and barricade lights within the project and around the perimeter of the project for the safety and protection of through and local traffic. This includes, but is not limited to: Advance, regulatory and warning signs; barricades and channeling devices at intersecting streets on which traffic is to be maintained; barricades at the ends of the project and at right-of-way lines for intersecting streets which are to be closed with the first usable street on each side of the project. Traffic regulators, where required by the Engineer, are included.

19.3 Where the existing pavement or partial widths of new pavement are to be utilized for the maintenance of through and local traffic, drum type barricades will be required at 50' intervals or as directed by the Engineer for channeling and directing traffic through the construction area.

19.4 Through traffic shall be maintained utilizing sidewalk closures with detours and traffic shifts per MDOT traffic and safety details.

19.5 Protection of all pedestrian traffic shall be maintained at all times.

19.6 Payment for the traffic control devices shall be based on the quantity used and the contract unit prices.

19.7 Under Article 812.04.D "Operated Pay Items" the term 'Relocating' shall include the relocating of the item from any street covered by the contract to any other street covered by the contract.

Special Restrictions: Access to frontage properties shall be maintained as much as practical. Emergency access shall be maintained at all times. The Contractor shall maintain two-way traffic with flag control as needed when the road is restricted to only one traffic lane.

20. **LIQUIDATED DAMAGES**

Liquidated damages, if applicable, shall be \$500.00 a day regardless of contract size.

21. REMOVAL OF RUBBISH

The Contractor shall daily remove all rubbish and accumulated materials due to his/her construction.

22. SITE ACCESS

The City will provide fair and reasonable access to the job site within the working schedules of both parties.

23. GUARANTEE

The Contractor shall guarantee all of his/her work for a period of two (2) years following the date of final acceptance of the completed work and shall repair, replace or make good any materials or work which fail to function or perform or be found defective, without cost to the City.

24. SAFETY

The Contractor shall comply with all applicable OSHA and MIOSHA regulations.

25. PAY ESTIMATES

The Contractor shall be responsible for the generation of invoices for payment. Contractor shall use One-Drive Project Spreadsheet. Payment will be generated by the City based upon an approved invoice. Recommended frequency of payment is monthly, however, frequency of payment will not exceed bi-weekly.

26. PRODUCT/SYSTEM SUBSTITUTIONS

Submit a written request, to be received not later than 10 days prior to scheduled bid opening, for Substitution of any Product not named. If no substitutions are submitted, it will be reasonably concluded by the Owner that the specified product will be incorporated into the Work and the Bidder will be committed to supplying the specified product.

26.1 Describe in detail any variance to the Product specified. All proposed substitution for specified items shall be substantially the same size (height, length, width, diameter, etc.), type, color, construction quality and shall meet the design intent to be considered for substitution for the Product specified.

26.2 Document each request with complete data substantiating compliance of proposed Substitution with Product specified including written certification that Product conforms to or exceeds all requirements of the Product specified.

26.3 Document all coordination information, including a list of changes or modifications needed to the Contract Documents or other parts of the Work and to construction performed by the Owner and Separate Contractors that will become necessary to accommodate the proposed substitution.

26.4 Provide name, address, and telephone number of manufacturer's authorized representative.

26.5 Submit three copies of all documents for each request for Substitution for consideration.

26.6 Approval of the Substitution request, if given, will be in the form of an addendum issued prior to scheduled opening date and hour at local time.

27. SAMPLES AND DEMONSTRATIONS

Evidence in the form of samples may be requested. Such samples are to be furnished after the date of bid opening only upon request of The City unless otherwise stated in the bid proposal. If samples should be requested, such samples must be received by The City no later than seven (7) days after formal request is made. When required, The City may request full demonstrations of any unit(s) bid prior to the award of any contract. Samples, when requested, must be furnished free of expense to The City and if not used in testing or destroyed, will upon request within thirty (30) days of bid award be returned at the bidder's request.

28. ACCEPTANCE OF MATERIAL

The material delivered under this proposal shall remain the property of the seller until a physical inspection and actual usage of the material and/or services is made and thereafter accepted to the satisfaction of The City and must comply with the terms herein and be full in accord with specifications and of the highest quality. In the event the material and/or service supplied to The City is found to be defective or does not conform to specifications, The City reserves the right to cancel the order upon written notice to the seller and return the product to seller at the seller's expense.

29. VARIATIONS TO SPECIFICATIONS

For purposes of evaluation, the bidder **MUST** indicate any variances from our specifications, terms and/or conditions, no matter how slight. If variations are not stated in the proposal, it will be assumed that the product or service fully complies with our specifications, terms and conditions.

30. SAFETY STANDARDS

The bidder warrants that the products supplied to The City conform in all respects to the standards set forth in the Occupational Safety and Health Act of 1970 and its amendments and the failure to comply with this condition will be considered a breach of contract.

31. MANUFACTURER'S CERTIFICATION

The City reserves the right to request from bidders separate manufacturer certification of all statements made in the bid.

32. PROTECTION OF WORK

The Contractor shall maintain adequate protection of all his/her work from damage and shall protect all public and private abutting property from injury or loss arising in connection with this contract.

33. PROTECTION OF PROPERTY

33.1 The Contractor shall confine his/her equipment and operations to those areas of the work site necessary for the completion of the work, or as authorized by the Project Manager. The Contractor shall protect and preserve from damage any facilities, utilities or features including trees, shrubs and turf which are not required to be disturbed by the requirements of the work.

33.2 The Contractor shall be responsible to determine the location of and to protect from damage any utilities or other improvements.

34. WORK HOURS

All work shall be done between the hours of 7 am to 7 pm (Monday – Saturday). Work done outside of these times will be at the discretion of the Project Manager.

No work shall be done on Sunday, unless otherwise approved by the Project Manager in writing.

No work shall be done on City Holidays, unless otherwise approved by the Project Manager in writing. City Holidays include: New Year’s Day, Good Friday, Memorial Day, Juneteenth, Independence Day, Labor Day, Veteran’s Day, Thanksgiving, Day after Thanksgiving, Christmas Eve, and Christmas Day.

The Contractor shall conduct their work in such a manner that no excavations are left open overnight. If this is not possible, the Contractor shall provide and install a temporary fence to protect the excavation, at the Contractor’s expense.

35. PROJECT MANAGER’S STATUS

The City Engineer (Engineer) or his/her duly authorized representative shall be the City’s Project Manager and shall have the duties and responsibilities as provided in the contract.

The Project Manager shall have the authority to reject any work or materials which do not conform to the contract and to decide questions or interpretations which may arise from the contract documents.

The Contractor shall immediately report to the Project Manager any questionable or obvious error or omission which may be apparent in the contract documents and shall not proceed with work until the Project Manager has resolved the error or omission.

36. QUESTIONS

Bidders shall address questions regarding the specifications to Anna Crandall, Assistant City Engineer at crandalla@kalamazoo-city.org. (This does not relieve the requirements of Page 1, Item 3.) Questions regarding terms, conditions and other related bid requirements may be addressed to Scott Shaffer, Buyer, at (269) 337-8444, or shaffers@kalamazoo-city.org.

SECTION VI
TERMS AND CONDITIONS

1. **AWARD OF CONTRACT**

- A. This contract will be awarded to that responsible bidder whose bid, conforming to this solicitation, will be most advantageous to the City, price and other factors considered. The City reserves the right to accept or reject any or all bids and waive informalities and minor irregularities in bids received. Other factors include, as an example but not limited to, delivery time, conformance to specifications, incidental costs such as demurrage and deposits, etc.

Notification of award will be in writing by the Purchasing Agent. Upon notification, the Contractor shall submit to the Purchasing Division all required insurance certificates (if required) and such other documentation as may be requested or required hereunder. Upon their receipt and subsequent approval by the City, the Purchasing Agent will forward to the Contractor a written **NOTICE TO PROCEED**. Work shall **NOT** be started until such **NOTICE TO PROCEED** is received by the Contractor.

- B. Unilateral changes in bid prices by the bidder shall not be allowed. However, the City, at its sole option, reserves the right to negotiate with bidders in the event of, but not limited to:
- 1) No bids received;
 - 2) A single bid being received; or
 - 3) Prices quoted are over budget and/or unreasonable.

2. **COMPLETE CONTRACT**

This bid document together with its addenda, amendments, attachments, and modifications, when executed, becomes the complete contract between the parties hereto, and no verbal or oral promises or representations made in conjunction with the negotiation of this contract shall be binding on either party.

3. **SUBCONTRACTORS – NON-ASSIGNMENT**

Bidders shall state in writing any and all sub-contractors to be associated with this bid, including the type of work to be performed. The Contractor shall cooperate with the City of Kalamazoo in meeting its commitments and goals with regard to maximum utilization of minority and women-owned business enterprises.

The Contractor hereby agrees and understands that the contract resulting from this solicitation shall not be transferred, assigned, or sublet without prior written consent of the City of Kalamazoo.

4. **TAXES**

The City of Kalamazoo is exempt from all federal excise tax and state sales and use taxes.

5. **INVOICING**

All original invoice(s) will be sent to the Financial Services Division, 241 W. South Street, Kalamazoo, MI 49007 or via email at apinvoice@kalamazoocity.org. The Finance Division processes payments after receipt of an original invoice from the Contractor and approval by the department. The City of Kalamazoo's policy is to pay invoice(s) within 30 days from the receipt of the original invoice, if the services or supplies are satisfactory and the proper paperwork and procedures have been followed. **In order to guarantee payment to the vendor on a timely basis, the vendor needs to receive a purchase order number before supplying the City of Kalamazoo with goods or services.** All original, and copies of original invoice(s), will clearly state which purchase order they are being billed against.

The City of Kalamazoo is a government municipality and therefore is tax exempt from all sales tax.

INVOICING (Cont.)

The vendor is responsible for supplying the Finance Division with a copy of their W9 if they are providing a service to the City of Kalamazoo.

6. PAYMENTS

Upon issuance of certificates of Payment by the Architect/Engineer for labor and material incorporated in the work and the materials suitably stored at the site payment shall be made up to ninety (90%) percent of the value thereof.

When the cumulative total of payment is equal to fifty (50%) percent of the contract sum, subsequent payments will be made in the full amount for labor and material certified by the Architect/Engineer.

The amount retained shall be held until final acceptance of the work, receipt of all payrolls, releases, and waiver of liens.

7. CHANGES AND/OR CONTRACT MODIFICATIONS

The City reserves the right to increase or decrease quantities, service or requirements, or make any changes necessary at any time during the term of this contract, or any negotiated extension thereof. Price adjustments due to any of the foregoing changes shall be negotiated and mutually agreed upon by the Contractor and the City.

Changes of any nature after contract award which reflect an increase or decrease in requirements or costs shall not be permitted without prior approval by the Purchasing Agent. City Commission approval may also be required.

ANY CHANGES PERFORMED IN ADVANCE OF PURCHASING AGENT APPROVAL, MAY BE SUBJECT TO DENIAL AND NON-PAYMENT.

8. LAWS, ORDINANCES AND REGULATIONS

The Contractor shall keep himself/herself fully informed of all local, state and federal laws, ordinances and regulations in any manner affecting those engaged or employed in the work and the equipment used. Contractor and/or employees shall, at all times, serve and comply with such laws, ordinances and regulations.

Any permits, licenses, certificates, or fees required for the performance of the work shall be obtained and paid for by the Contractor.

This contract shall be governed by the laws of the State of Michigan.

9. RIGHT TO AUDIT

The City or its designee shall be entitled to audit all of the Contractor's records, and shall be allowed to interview any of the Contractor's employees, throughout the term of this contract and for a period of three years after final payment or longer if required by law to the extent necessary to adequately permit evaluation and verification of:

- A. Contractor compliance with contract requirements,
- B. Compliance with provisions for pricing change orders, invoices or claims submitted by the Contractor or any of his payees.

10. HOLD HARMLESS

If the negligent acts or omissions of the Contractor/Vendor or its employees, agents or officers, cause injury to person or property, the Contractor/Vendor shall indemnify and save harmless the City of Kalamazoo, its agents, officials, and employees against all claims, judgments, losses, damages, demands, and payments of any kind to persons or property to the extent occasioned from any claim or demand arising therefrom.

11. DEFAULT

The City may at any time, by written notice to the Contractor, terminate this contract and the Contractor's right to proceed with the work, for just cause, which shall include, but is not limited to the following:

- A. Failure to provide insurance and bonds (when called for), in the exact amounts and within the time specified or any extension thereof.
- B. Failure to make delivery of the supplies, or to perform the services within the time specified herein, or any extension thereof.
- C. The unauthorized substitution of articles for those bid and specified.
- D. Failure to make progress if such failure endangers performance of the contract in accordance with its terms.
- E. Failure to perform in compliance with any provision of the contract.
- F. **Standard of Performance** - Contractor guarantees the performance of the commodities, goods or services rendered herein in accordance with the accepted standards of the industry or industries concerned herein, except that if this specification calls for higher standards, then such higher standards shall be provided.

Upon notice by the City of Contractor's failure to comply with such standards or to otherwise be in default of this contract in any manner following the Notice to Proceed, Contractor shall immediately remedy said defective performance in a manner acceptable to the City. Should Contractor fail to immediately correct said defective performance, said failure shall be considered a breach of this contract and grounds for termination of the same by the City.

In the event of any breach of this contract by Contractor, Contractor shall pay any cost to the City caused by said breach including but not limited to the replacement cost of such goods or services with another Contractor.

The City reserves the right to withhold any or all payments until any defects in performance have been satisfactorily corrected.

In the event the Contractor is in breach of this contract in any manner, and such breach has not been satisfactorily corrected, the City may bar the Contractor from being awarded any future City contracts.

- G. All remedies available to the City herein are cumulative and the election of one remedy by the City shall not be a waiver of any other remedy available to the City.

12. TERMINATION OF CONTRACT

The City may, at any time and without cause, suspend the work of this contract for a period of not more than ninety days after providing notice in writing to the Contractor. The Contractor shall be allowed an adjustment in the contract price or an extension of the contract times, or both, directly attributable to the suspension if Contractor makes an approved claim.

The City may, without prejudice to any other right or remedy of the City, and with or without cause, terminate the contract by giving seven days written notice to the Contractor. In such case the Contractor shall be paid, without duplication, for the following items:

- A. Completed and acceptable work executed in accordance with the contract documents prior to the effective date of termination, including fair and reasonable sums for overhead and profit on such work;

TERMINATION OF CONTRACT (Cont.)

- B. Expenses sustained prior to the effective date of termination in performing services and furnishing labor, materials or equipment as required by the contract documents in connection with uncompleted work, plus fair and reasonable sums for overhead and profit on such expenses;
- C. All documented claims, costs, losses and damages incurred in settlement of terminated contracts with Subcontractors, Suppliers and others; and
- D. Reasonable expenses directly attributable to termination.

The Contractor shall not be paid on account of loss of anticipated profits or revenue or other economic loss arising out of or resulting from such termination.

13. INDEPENDENT CONTRACTOR

At all times, the Contractor, any of his/her employees, or his/her sub-contractors and their subsequent employees shall be considered independent contractors and not as City employees. The Contractor shall exercise all supervisory control and general control over all workers' duties, payment of wages to Contractor's employees and the right to hire, fire and discipline their employees and workers. As an independent contractor, payment under this contract shall not be subject to any withholding for tax, social security or other purposes, nor shall the Contractor or his/her employees be entitled to sick leave, pension benefit, vacation, medical benefits, life insurance or workers' unemployment compensation or the like.

14. PROJECT SUPERVISOR

The Contractor shall employ an individual to act as Project Supervisor. The Project Supervisor shall be available to the Contractor's workers and the Project Manager at all times by use of a beeper or other reliable means. The Project Supervisor shall prepare daily work plans for the employees, monitor employee performance, attendance and punctuality; and work closely with the City's Project Manager in assuring contract compliance.

15. MEETINGS

The Contractor and/or Project Supervisor shall be available to meet with the Department Head or Project Manager at a mutually agreeable time to discuss problems, issues or concerns relative to the contract. Either party may call a meeting at any time. When such a request for a meeting is made, the meeting date shall, in no case exceed five (5) working days after the request; and, if in the sole opinion of the Department Head, the severity of the circumstance warrants, no more than one (1) working day.

16. INSPECTION OF WORK SITE

Before submitting bids or quotes for work, the Contractor shall be responsible for examining the work site and satisfying himself/herself as to the existing conditions under which he/she will be obligated to operate, or that in any way affects the work under this contract. No allowance shall be made subsequently, on behalf of the Contractor, for any negligence on his/her part.

17. CONTRACT PERIOD, EXTENSIONS, CANCELLATION

- A. The contract shall be in effect for the term stated in the specifications.
- B. The City may opt to extend this contract upon mutual agreement of both parties. The number of extensions shall be limited to that stated in the specifications.
- C. The City may, from time to time, find it necessary to continue this contract on a month-to-month basis only, not to exceed a six (6) month period. Such month-to-month extended periods shall be by mutual agreement of both parties, with all provisions of the original contract or any extension thereof remaining in full force and effect.
- D. All contracts, extensions and cost increases are subject to availability of funds and the approval of the City Commission (if required).
- E. The City reserves the right to cancel the contract due to non-appropriation of funds by the City with thirty (30) days written notice.
- F. Either party may terminate the contract (or any extension thereof) without cause at the end of any twelve (12) month term by giving written notice of such intent at least 60 days prior to the end of said twelve (12) month term.
- G. All notices are in effect commencing with the date of mailing. Written notices may be delivered in person or sent by First Class mail; or emailed to the last known address.
- H. If cancellation is for default of contract due to non-performance, the contract may be canceled at any time (see Item 11, DEFAULT)

APPENDIX A
NON-DISCRIMINATION CLAUSE FOR ALL CITY OF KALAMAZOO CONTRACTS

The Contractor agrees to comply with the Federal Civil Rights Act of 1964 as amended; the Federal Civil Rights Act of 1991 as amended; the Americans With Disabilities Act of 1990 as amended; the Elliott-Larson Civil Rights Act, Act. No. 453, Public Act of 1976 as amended; the Michigan Handicappers Civil Rights Act, Act No. 220, Public Act of 1976 as amended, City Ordinance 1856 and all other applicable Federal and State laws. The Contractor agrees as follows:

1. The Contractor will not discriminate against any employee or applicant for employment because of race, color, religion, national origin, sex, age, height, weight, marital status, physical or mental disability, family status, sexual orientation or gender identity that is unrelated to the individual's ability to perform the duties of the particular job or position. Such action shall include, but not be limited to the following: employment, upgrading, demotion or transfer, recruitment advertising, layoff or termination; rates of pay or other forms of compensations; and selection for training, including apprenticeship.
2. The Contractor will, in all solicitations or advertisements for employees placed by or on behalf of the Contractor, state that all qualified applicants will receive consideration for employment without regard to race, color, religion, national origin, sex, age, height, weight, marital status, physical or mental disability family status, sexual orientation or gender identity that is unrelated to the individual's ability to perform the duties of the particular job or position.
3. If requested by the City, the Contractor shall furnish information regarding practices, policies and programs and employment statistics for the Contractor and subcontractors. The Contractor and subcontractors shall permit access to all books, records and accounts regarding employment practices by agents and representatives of the City duly charged with investigative duties to assure compliance with this clause.
4. Breach of the covenants herein may be regarded as a material breach of the contract or purchasing agreement as provided in the Elliott-Larsen Civil Rights Act and City Ordinance 1856.
5. The Contractor will include or incorporate by reference the provisions of the foregoing paragraphs 1 through 4 in every subcontract or purchase order unless exempted by the rules, regulations or orders of the Michigan Civil Rights Commission* and will provide in every subcontract or purchase order that said provision will be binding upon each subcontractor or seller.
6. The Contractor will not preclude a person with a criminal conviction from being considered for employment unless otherwise precluded by federal or state law. (for contracts over \$25,000)

The Elliott-Larson Civil Rights Act, Sec. 202 of Act. No. 453 of 1976 reads in part as follows:

Sec. 202. (1) An employer shall not:

- (a) Fail or refuse to hire, or recruit, or discharge or otherwise discriminate against an individual with respect to employment, compensation, or a term condition or privilege of employment because of religion, race, color, national origin, age, sex, height, weight or marital status.
- (b) Limit, segregate or classify an employee or applicant for employment in a way which deprives or tends to deprive the employee or applicant of an employment opportunity or otherwise adversely affects the status of an employee or applicant because of religion, race, color, national origin, age, sex, height, weight or marital status.
- (c) Segregate, classify or otherwise discriminate against a person on the basis of sex with respect to a term, condition or privilege of employment, including a benefit plan or system.

* Except for contracts entered with parties employing less than three employees.

APPENDIX B - PREVAILING WAGES

Prevailing wages are applicable to this contract; therefore, rates will apply as follows:

- (XX) Project is funded by City of Kalamazoo monies and is estimated to be in excess of \$100,000.00. The applicable prevailing wage rates are attached.

Specifications for projects in which the City of Kalamazoo is party for construction, alterations and/or repair including painting and decorating of public buildings or public works in or for the City of Kalamazoo and which requires or involves the employment of mechanics and/or laborers shall contain the following provisions stating the minimum wages to be paid the various classes of laborers and mechanics for the project. Prevailing wage rates determined by the U.S. Department of Labor under Davis Bacon and related acts will be used for City of Kalamazoo construction projects.

By the incorporation of prevailing wage rates within this specification, the City of Kalamazoo stipulates that:

- ✓ Contractor or his/her subcontractor shall pay all mechanics and laborers employed directly upon the site of the work, unconditionally and not less than once a week and without subsequent deduction or rebate on any account the full amount, accrued at the time of payment, computed at wage rates as incorporated herein regardless of any contractual relationship which may be alleged to exist between the contractor or subcontractor and such laborers and mechanics;
- ✓ The scale of wages to be paid shall be posted by the contractor in a prominent and easily accessible place at the site of the work;
- ✓ The Prime Contractor and all subcontractors shall submit weekly certified payrolls documenting the hours worked and wages paid by work classification. **NOTE: Contactor shall not include Social Security numbers of employees on certified payrolls.**
- ✓ There may be withheld from the contractor's accrued payments the amount considered necessary by the City's Contracting Official to pay to laborers and mechanics employed by the contractor or any subcontractor on the work for the difference between the rates of wages required by the contract and the rates of wages received by such laborers and mechanics except those amounts properly deducted or refunded pursuant to the terms of the Davis-Bacon Act (USC, Title 40, Sec. 276a) and interpretations thereof.

Special Note: The City's requirements as it relates to prevailing wages **includes a meeting with the City's Purchasing Agent prior to starting work and the submission of weekly certified payrolls by prime contractors and all subcontractors.** The City will monitor certified payrolls, work progress, and conduct interviews with the mechanics and labors employed directly upon the site during the duration of the contract Please contact the Purchasing Department at (269) 337-8020 if you have any questions regarding prevailing wage provision.

The overtime pay to which a laborer or mechanic is entitled under this contract shall be that overtime pay to which he/she is entitled by any agreement made with the contractor or subcontractor or by any applicable provision of law; but in no event shall such amount be less than the prevailing wage in the Kalamazoo community for such overtime.

Revised 4-08



EGLE FORMS & PREVAILING WAGES

**DWSRF Non-Copper Service Line
Replacement FY 26**

Bid Reference #: 91244-051.0

April 2026



MICHIGAN DEPARTMENT OF ENVIRONMENT, GREAT LAKES, AND ENERGY
Finance Division

EQUIVALENCY PROJECTS CONTRACT BOILERPLATE LANGUAGE

Instructions:

The following is the required standard contract language that must appear in bidding documents of Clean Water State Revolving Fund and Drinking Water State Revolving Fund equivalency projects. Determination of equivalent vs. non-equivalent projects is made on a yearly basis as indicated in the Intended Use Plan (IUP) and will be communicated by your EGLE project manager. If you are unsure whether your project is equivalent, consult with your EGLE project manager.

- **Domestic Preference Requirements**
 - All projects must comply with federal domestic preference requirements. For equivalency projects this means compliance with Build America, Buy America (BABA) requirements unless a waiver is received, then the project must comply with existing American Iron and Steel (AIS) requirements. Only either [BABA Contract Language](#) or [AIS Contract Language](#) should appear in the bidding documents, not both.
- [Prohibition on Certain Telecommunications and Video Surveillance Services or Equipment](#)
- [Davis-Bacon and Related Acts/Prevailing Federal Wages](#)
- [Labor Standards Provisions for Federally Assisted Projects](#)
- [Disadvantaged Business Enterprise \(DBE\) Requirements](#)
- [Good Faith Efforts \(GFE\) Worksheet*](#)
- [Certification Regarding Debarment, Suspension, and Other Responsibility Matters*](#)

*Bidders should note these sections contain instructions regarding forms/information that must be completed and included with any submitted bid.

If you need this information in an alternate format, contact EGLE-Accessibility@Michigan.gov or call 800-662-9278.

EGLE does not discriminate on the basis of race, sex, religion, age, national origin, color, marital status, disability, political beliefs, height, weight, genetic information, or sexual orientation in the administration of any of its programs or activities, and prohibits intimidation and retaliation, as required by applicable laws and regulations. Questions or concerns should be directed to the Nondiscrimination Compliance Coordinator at EGLE-NondiscriminationCC@Michigan.gov or 517-249-0906.

Build America, Buy America Contract Language

The Contractor acknowledges to and for the benefit of the City of **Kalamazoo** (“Owner”) and the Michigan Department of Environment, Great Lakes, and Energy (the “Funding Authority”) that it understands the goods and services under this Agreement are being funded with federal monies and have statutory requirements commonly known as “Build America, Buy America;” that requires all of the iron and steel, manufactured products, and construction materials used in the project to be produced in the United States (“Build America, Buy America Requirements”) including iron and steel, manufactured products, and construction materials provided by the Contractor pursuant to this Agreement. The Contractor hereby represents and warrants to and for the benefit of the Owner and Funding Authority (a) the Contractor has reviewed and understands the Build America, Buy America Requirements, (b) all of the iron and steel, manufactured products, and construction materials used in the project will be and/or have been produced in the United States in a manner that complies with the Build America, Buy America Requirements, unless a waiver of the requirements is approved, and (c) the Contractor will provide any further verified information, certification or assurance of compliance with this paragraph, or information necessary to support a waiver of the Build America, Buy America Requirements, as may be requested by the Owner or the Funding Authority. Notwithstanding any other provision of this Agreement, any failure to comply with this paragraph by the Contractor shall permit the Owner or Funding Authority to recover as damages against the Contractor any loss, expense, or cost (including without limitation attorney’s fees) incurred by the Owner or Funding Authority resulting from any such failure (including without limitation any impairment or loss of funding, whether in whole or in part, from the Funding Authority or any damages owed to the Funding Authority by the Owner). If the Contractor has no direct contractual privity with the Funding Authority, as a lender or awardee to the Owner for the funding of its project, the Owner and the Contractor agree that the Funding Authority is a third-party beneficiary and neither this paragraph (nor any other provision of this Agreement necessary to give this paragraph force or effect) shall be amended or waived without the prior written consent of the Funding Authority.

Prohibition on Certain Telecommunications and Video Surveillance Services or Equipment

The Contractor acknowledges to and for the benefit of the City of **Kalamazoo** (“Owner”) and the Michigan Department of Environment, Great Lakes, and Energy (the “Funding Authority”) that it understands:

This term and condition implements 2 CFR 200.216 and is effective for obligations and expenditures of the U.S. Environmental Protection Agency (or EPA)’s financial assistance funding on or after 8/13/2020.

As required by 2 CFR 200.216, EPA recipients and subrecipients, including borrowers under EPA funded revolving loan fund programs, are prohibited from obligating or expending loan or grant funds to procure or obtain; extend or renew a contract to procure or obtain; or enter into a contract (or extend or renew a contract) to procure or obtain equipment, services, or systems that use covered telecommunications equipment or services as a substantial or essential component of any system, or as critical technology as part of any system. As described in Public Law 115-232, section 889, covered telecommunications equipment is telecommunications equipment produced by Huawei Technologies Company or ZTE Corporation (or any subsidiary or affiliate of such entities). Recipients, subrecipients, and borrowers also may not use EPA funds to purchase:

- a. For the purpose of public safety, security of government facilities, physical security surveillance of critical infrastructure, and other national security purposes, video surveillance and telecommunications equipment produced by Hytera Communications Corporation, Hangzhou Hikvision Digital Technology Company, or Dahua Technology Company (or any subsidiary or affiliate of such entities).
- b. Telecommunications or video surveillance services provided by such entities or using such equipment.
- c. Telecommunications or video surveillance equipment or services produced or provided by an entity that the Secretary of Defense, in consultation with the Director of the National Intelligence or the Director of the Federal Bureau of Investigation, reasonably believes to be an entity owned or controlled by, or otherwise connected to, the government of a covered foreign country.

Consistent with 2 CFR 200.471, costs incurred for telecommunications and video surveillance services or equipment such as phones, internet, video surveillance, and cloud servers are allowable except for the following circumstances:

- a. Obligating or expending EPA funds for covered telecommunications and video surveillance services or equipment or services as described in 2 CFR 200.216 to:
 - (1) Procure or obtain, extend or renew a contract to procure or obtain;
 - (2) Enter into a contract (or extend or renew a contract) to procure; or
 - (3) Obtain the equipment, services, or systems. Certain prohibited equipment, systems, or services, including equipment, systems, or services produced or provided by entities identified in section 889, are recorded in the System for Award Management exclusion list.

Davis-Bacon and Related Acts/Prevailing Federal Wages

P.L. 111-88 requires compliance with the Davis Bacon Act and adherence to the current U.S. Department of Labor Wage Decision. Attention is called to the fact that not less than the minimum salaries and wages as set forth in the Contract Documents (see Wage Decision included herein) must be paid on this project. The Wage Decision, including modifications, must be posted by the Contractor on the job site. The “Contracting Agency” or “Contracting Officer” for Davis-Bacon Wage Decision posters on jobsites is the loan applicant/bond issuer. A copy of the Labor Standards Provisions for Federally Assisted Projects is included and is hereby a part of this contract.

"General Decision Number: MI20260061 01/02/2026

Superseded General Decision Number: MI20250061

State: Michigan

Construction Type: Heavy

County: Kalamazoo County in Michigan.

Heavy, Includes Water, Sewer Lines and Excavation (Excludes Hazardous Waste Removal; Coal, Oil, Gas, Duct and other similar Pipeline Construction)

Modification Number 0 Publication Date 01/02/2026

CARP0525-006 06/01/2023

	Rates	Fringes
CARPENTER, Includes Form Work....	\$ 28.29	21.42

ELEC0131-006 06/01/2025

	Rates	Fringes
ELECTRICIAN.....	\$ 42.78	21.84

ENGI0325-009 09/01/2025

POWER EQUIPMENT OPERATORS: Underground Construction (Including Sewer)

	Rates	Fringes
POWER EQUIPMENT OPERATOR		
GROUP 1.....	\$ 45.98	25.25
GROUP 2.....	\$ 41.25	25.25
GROUP 3.....	\$ 40.52	25.25
GROUP 4.....	\$ 39.95	25.25

POWER EQUIPMENT OPERATOR CLASSIFICATIONS

GROUP 1: Backhoe/ Excavator, Boring Machine, Bulldozer, Crane, Grader/ Blade, Loader, Roller, Scraper, Trencher (over 8 ft. digging capacity)

GROUP 2: Trencher (8-ft digging capacity and smaller)

GROUP 3: Boom Truck (non-swinging, non- powered type boom)

GROUP 4: Broom/ Sweeper, Fork Truck, Tractor, Bobcat/ Skid Steer /Skid Loader

ENGI0326-025 06/01/2025

EXCLUDES UNDERGROUND CONSTRUCTION

Rates Fringes

OPERATOR: Power Equipment

GROUP 1.....	\$ 48.98	25.25
GROUP 2.....	\$ 45.68	25.25
GROUP 3.....	\$ 44.00	25.25
GROUP 4.....	\$ 41.32	25.25
GROUP 5.....	\$ 41.32	25.25
GROUP 6.....	\$ 35.46	25.25
GROUP 7.....	\$ 32.98	25.25

PAID HOLIDAYS: New Year's Day, Memorial Day, Fourth of July, Labor Day, Thanksgiving Day and Christmas Day.

POWER EQUIPMENT OPERATOR CLASSIFICATIONS

GROUP 1: Crane operator with main boom and jib 400', 300', or 220' or longer.

GROUP 2: Crane operator with main boom and jib 140' or longer, tower crane, gantry crane, whirley derrick

GROUP 3: Backhoe/Excavator; Boring Machine; Bulldozer; Crane; Grader/Blade; Loader; Roller; Scraper; Tractor; Trencher

GROUP 4: Bobcat/Skid Loader; Broom/Sweeper; Fork Truck (over 20' lift)

GROUP 5: Boom truck (non-swinging)

GROUP 6: Fork Truck (20' lift and under for masonry work)

GROUP 7: Oiler

FOOTNOTES:

Crane operator with main boom and jib 300' or longer: \$1.50 per hour above the group 1 rate.

Crane operator with main boom and jib 400' or longer: \$3.00 per hour above the group 1 rate.

IRON0025-011 06/01/2025

	Rates	Fringes
IRONWORKER (REINFORCING).....	\$ 36.55	34.04
IRONWORKER (STRUCTURAL).....	\$ 36.55	34.04

LAB00334-011 09/01/2022

SCOPE OF WORK:

OPEN CUT CONSTRUCTION: Excavation of earth and sewer, utilities, and improvements, including underground piping/conduit (including inspection, cleaning, restoration, and relining)

	Rates	Fringes
LABORER		
(1) Common or General.....	\$ 22.42	12.95
(2) Mason Tender- Cement/Concrete.....	\$ 22.55	12.95
(4) Grade Checker.....	\$ 22.73	12.95

(5) Pipelayer.....\$ 22.85 12.95

LAB00355-010 06/01/2025

EXCLUDES OPEN CUT CONSTRUCTION

Rates Fringes

LABORER

Common or General; Grade Checker; Mason Tender - Cement/Concrete.....\$ 27.21 13.45 Pipelayer.....\$ 20.34 12.85

PAIN0312-014 06/12/2014

Rates Fringes

PAINTER

Brush & Roller.....\$ 21.75 11.94 Spray.....\$ 22.75 11.94

PLAS0016-020 04/01/2014

Rates Fringes

CEMENT MASON/CONCRETE FINISHER...\$ 22.31 12.83

PLUM0333-026 06/01/2022

Fort Custer

Rates Fringes

PLUMBER.....\$ 42.29 23.94

PLUM0357-012 07/01/2020

Excluding Fort Custer

Rates Fringes

PLUMBER.....\$ 35.20 22.35

TEAM0007-011 06/01/2025

Rates Fringes

TRUCK DRIVER

Lowboy/Semi-Trailer Truck...\$ 33.55 .75 + a+b Tractor Haul Truck.....\$ 33.30 .75 + a+b

FOOTNOTE:

- a. \$470.70 per week. b. \$68.70 daily.

SUMI2010-059 11/09/2010

Rates Fringes

LABORER: Landscape.....\$ 12.25 0.00

TRUCK DRIVER: Dump Truck.....\$ 18.00 6.43

TRUCK DRIVER: Off the Road

Truck.....\$ 20.82 3.69

WELDERS - Receive rate prescribed for craft performing operation to which welding is incidental.

Note: Executive Order (EO) 13706, Establishing Paid Sick Leave for Federal Contractors applies to all contracts subject to the Davis-Bacon Act for which the contract is awarded (and any solicitation was issued) on or after January 1, 2017. If this contract is covered by the EO, the contractor must provide employees with 1 hour of paid sick leave for every 30 hours they work, up to 56 hours of paid sick leave each year. Employees must be permitted to use paid sick leave for their own illness, injury or other health-related needs, including preventive care; to assist a family member (or person who is like family to the employee) who is ill, injured, or has other health-related needs, including preventive care; or for reasons resulting from, or to assist a family member (or person who is like family to the employee) who is a victim of, domestic violence, sexual assault, or stalking. Additional information on contractor requirements and worker protections under the EO is available at https://www.dol.gov/agencies/whd/government-contracts.

Note: Executive Order 13658 generally applies to contracts subject to the Davis-Bacon Act that were awarded on or between January 1, 2015 and January 29, 2022, and that have not been renewed or extended on or after January 30, 2022. Executive Order 13658 does not apply to contracts subject only to the Davis-Bacon Related Acts regardless of when they were awarded. If a contract is subject to Executive Order 13658, the contractor must pay all covered workers at least \$13.30 per hour (or the applicable wage rate listed on this wage determination, if it is higher) for all hours spent performing on the contract in 2025. The applicable Executive Order minimum wage rate will be adjusted annually. Additional information on contractor requirements and worker protections under Executive Order 13658 is available at www.dol.gov/whd/govcontracts.

Unlisted classifications needed for work not included within the scope of the classifications listed may be added after award only as provided in the labor standards contract clauses (29CFR 5.5 (a) (1) (iii)).

The body of each wage determination lists the classifications and wage rates that have been found to be prevailing for the type(s) of construction and geographic area covered by the wage determination. The classifications are listed in alphabetical order under rate identifiers indicating whether the particular rate is a union rate (current union negotiated rate), a survey rate, a weighted union average rate, a state adopted rate, or a supplemental classification rate.

Union Rate Identifiers

A four-letter identifier beginning with characters other than ""SU"", ""UAVG"", ?SA?, or ?SC? denotes that a union rate was prevailing for that classification in the survey. Example:

PLUM0198-005 07/01/2024. PLUM is an identifier of the union whose collectively bargained rate prevailed in the survey for this classification, which in this example would be Plumbers. 0198 indicates the local union number or district council number where applicable, i.e., Plumbers Local 0198. The next number, 005 in the example, is an internal number used in processing the wage determination. The date, 07/01/2024 in the example, is the effective date of the most current negotiated rate.

Union prevailing wage rates are updated to reflect all changes over time that are reported to WHD in the rates in the collective bargaining agreement (CBA) governing the classification.

Union Average Rate Identifiers

The UAVG identifier indicates that no single rate prevailed for those classifications, but that 100% of the data reported for the classifications reflected union rates. EXAMPLE: UAVG-OH-0010 01/01/2024. UAVG indicates that the rate is a weighted union average rate. OH indicates the State of Ohio. The next number, 0010 in the example, is an internal number used in producing the wage determination. The date, 01/01/2024 in the example, indicates the date the wage determination was updated to reflect the most current union average rate.

A UAVG rate will be updated once a year, usually in January, to reflect a weighted average of the current rates in the collective bargaining agreements on which the rate is based.

Survey Rate Identifiers

The "SU" identifier indicates that either a single non-union rate prevailed (as defined in 29 CFR 1.2) for this classification in the survey or that the rate was derived by computing a weighted average rate based on all the rates reported in the survey for that classification. As a weighted average rate includes all rates reported in the survey, it may include both union and non-union rates. Example: SUFL2022-007 6/27/2024. SU indicates the rate is a single non-union prevailing rate or a weighted average of survey data for that classification. FL indicates the State of Florida. 2022 is the year of the survey on which these classifications and rates are based. The next number, 007 in the example, is an internal number used in producing the wage determination. The date, 6/27/2024 in the example, indicates the survey completion date for the classifications and rates under that identifier.

?SU? wage rates typically remain in effect until a new survey is conducted. However, the Wage and Hour Division (WHD) has the discretion to update such rates under 29 CFR 1.6(c)(1).

State Adopted Rate Identifiers

The "SA" identifier indicates that the classifications and prevailing wage rates set by a state (or local) government were adopted under 29 C.F.R 1.3(g)-(h). Example: SAME2023-007 01/03/2024. SA reflects that the rates are state adopted. ME refers to the State of Maine. 2023 is the year during which the state completed the survey on which the listed classifications and rates are based. The next number, 007 in the example, is an internal number used in producing the wage determination. The date, 01/03/2024 in the example, reflects the date on which the classifications and rates under the ?SA? identifier took

effect under state law in the state from which the rates were adopted.

WAGE DETERMINATION APPEALS PROCESS

1) Has there been an initial decision in the matter? This can be:

- a) a survey underlying a wage determination
- b) an existing published wage determination
- c) an initial WHD letter setting forth a position on a wage determination matter
- d) an initial conformance (additional classification and rate) determination

On survey related matters, initial contact, including requests for summaries of surveys, should be directed to the WHD Branch of Wage Surveys. Requests can be submitted via email to davisbaconinfo@dol.gov or by mail to:

Branch of Wage Surveys
Wage and Hour Division
U.S. Department of Labor
200 Constitution Avenue, N.W.
Washington, DC 20210

Regarding any other wage determination matter such as conformance decisions, requests for initial decisions should be directed to the WHD Branch of Construction Wage Determinations. Requests can be submitted via email to BCWD-Office@dol.gov or by mail to:

Branch of Construction Wage Determinations
Wage and Hour Division
U.S. Department of Labor
200 Constitution Avenue, N.W.
Washington, DC 20210

2) If an initial decision has been issued, then any interested party (those affected by the action) that disagrees with the decision can request review and reconsideration from the Wage and Hour Administrator (See 29 CFR Part 1.8 and 29 CFR Part 7). Requests for review and reconsideration can be submitted via email to dba.reconsideration@dol.gov or by mail to:

Wage and Hour Administrator
U.S. Department of Labor
200 Constitution Avenue, N.W.
Washington, DC 20210

The request should be accompanied by a full statement of the interested party's position and any information (wage payment data, project description, area practice material, etc.) that the requestor considers relevant to the issue.

3) If the decision of the Administrator is not favorable, an interested party may appeal directly to the Administrative Review Board (formerly the Wage Appeals Board). Write to:

Administrative Review Board
U.S. Department of Labor
200 Constitution Avenue, N.W.
Washington, DC 20210.

=====

END OF GENERAL DECISION

"

"General Decision Number: MI20260001 01/09/2026

Superseded General Decision Number: MI20250001

State: Michigan

Construction Types: Highway (Highway, Airport & Bridge xxxxx and Sewer/Incid. to Hwy.)

Counties: Michigan Statewide.

Modification Number	Publication Date
0	01/02/2026
1	01/09/2026

* CARP0004-004 06/01/2025

REMAINDER OF STATE

	Rates	Fringes
CARPENTER (Piledriver).....	\$ 35.57	21.54

* CARP0004-005 06/01/2025

LIVINGSTON (Townships of Brighton, Deerfield, Genoa, Hartland, Oceola & Tyrone), MACOMB, MONROE, OAKLAND, SANILAC, ST. CLAIR AND WAYNE COUNTIES

	Rates	Fringes
CARPENTER (Piledriver).....	\$ 41.37	28.69

ELEC0017-005 06/01/2025

STATEWIDE

	Rates	Fringes
Line Construction		
Groundman/Driver.....	\$ 33.32	33%+7.40
Journeyman Signal Tech, Communications Tech, Tower Tech & Fiber Optic Splicers.	\$ 49.26	33%+7.40
Journeyman Specialist.....	\$ 56.65	33%+7.40
Operator A.....	\$ 41.71	33%+7.40
Operator B.....	\$ 38.98	33%+7.40

Classifications

Journeyman Specialist: Refers to a crew of only one person working alone.
 Operator A: Shall be proficient in operating all power equipment including: Backhoe, Excavator, Directional Bore and Boom/Digger truck.
 Operator B: Shall be proficient in operating any 2 of the above mentioned pieces of equipment listed under Operator A.

ENGI0324-003 06/01/2025

ALCONA, ALPENA, ARENAC, BAY, CHEBOYGAN, CLARE, CLINTON, CRAWFORD, GENESEE, GLADWIN, GRATIOT, HURON, INGHAM, IOSCO, ISABELLA, JACKSON, LAPEER, LENAWEE, LIVINGSTON, MACOMB, MIDLAND, MONROE, MONTMORENCY, OAKLAND, OGEMAW, OSCODA, OTSEGO, PRESQUE ISLE, ROSCOMMON, SAGINAW, ST. CLAIR, SANILAC, SHIAWASSEE, TUSCOLA, WASHTENAW AND WAYNE COUNTIES:

	Rates	Fringes
OPERATOR: Power Equipment (Steel Erection)		
GROUP 1.....	\$ 55.42	28.25
GROUP 2.....	\$ 56.42	28.25
GROUP 3.....	\$ 53.92	28.25
GROUP 4.....	\$ 54.92	28.25
GROUP 5.....	\$ 52.42	28.25
GROUP 6.....	\$ 53.42	28.25
GROUP 7.....	\$ 52.15	28.25
GROUP 8.....	\$ 53.15	28.25
GROUP 9.....	\$ 51.70	28.25
GROUP 10.....	\$ 52.70	28.25
GROUP 11.....	\$ 50.97	28.25
GROUP 12.....	\$ 51.97	28.25
GROUP 13.....	\$ 50.61	28.25
GROUP 14.....	\$ 51.61	28.25
GROUP 15.....	\$ 49.97	28.25
GROUP 16.....	\$ 46.77	28.25
GROUP 17.....	\$ 32.29	15.40
GROUP 18.....	\$ 35.78	28.25

FOOTNOTE:

Paid Holidays: New Year's Day, Memorial Day, Fourth of July, Labor Day, Thanksgiving Day and Christmas Day.

POWER EQUIPMENT OPERATOR CLASSIFICATIONS

GROUP 1: Engineer when operating combination of boom and jib 400' or longer

GROUP 2: Engineer when operating combination of boom and jib 400' or longer on a crane that requires an oiler

GROUP 3: Engineer when operating combination of boom and jib 300' or longer

GROUP 4: Engineer when operating combination of boom and jib 300' or longer on a crane that requires an oiler

GROUP 5: Engineer when operating combination of boom and jib 220' or longer

GROUP 6: Engineer when operating combination of boom and jib 220' or longer on a crane that requires an oiler

GROUP 7: Engineer when operating combination of boom and jib 140' or longer

GROUP 8: Engineer when operating combination of boom and jib 140' or longer on a crane that requires an oiler

GROUP 9: Tower crane & derrick operator (where operator's work station is 50 ft. or more above first sub-level)

GROUP 10: Tower crane & derrick operator (where operator's work station is 50 ft. or more above first sub-level) on a crane that requires an oiler

GROUP 11: Engineer when operating combination of boom and jib 120' or longer

GROUP 12: Engineer when operating combination of boom and jib 120' or longer on a crane that requires an oiler

GROUP 13: Crane operator; job mechanic and 3 drum hoist and excavator

GROUP 14: Crane operator on a crane that requires an oiler

GROUP 15: Hoisting operator; 2 drum hoist and rubber tired backhoe

GROUP 16: Forklift and 1 drum hoist

GROUP 17: Compressor or welder operator

GROUP 18: Oiler

 ENGI0324-004 06/01/2025

AREA 1: ALLEGAN, BARRY, BERRIEN, BRANCH, CALHOUN, CASS, EATON, HILLSDALE, IONIA, KALAMAZOO, KENT, LAKE, MANISTEE, MASON, MECOSTA, MONTCALM, MUSKEGON, NEWAYGO, OCEANA, OSCEOLA, OTTAWA, ST. JOSEPH, VAN BUREN

AREA 2: ANTRIM, BENZIE, CHARLEVOIX, EMMET, GRAND TRAVERSE, KALKASKA, LEELANAU, MISSAUKEE AND WEXFORD COUNTIES:

	Rates	Fringes
OPERATOR: Power Equipment (Steel Erection)		
AREA 1		
GROUP 1.....	\$ 55.02	28.25
GROUP 2.....	\$ 52.15	28.25
GROUP 3.....	\$ 50.61	28.25
GROUP 4.....	\$ 46.77	28.25
GROUP 5.....	\$ 32.29	15.40
GROUP 6.....	\$ 35.78	28.25
AREA 2		
GROUP 1.....	\$ 55.02	28.25
GROUP 2.....	\$ 52.15	28.25
GROUP 3.....	\$ 50.61	28.25
GROUP 4.....	\$ 46.77	28.25
GROUP 5.....	\$ 32.29	15.40
GROUP 6.....	\$ 35.78	28.25

FOOTNOTES:

Crane operator with main boom and jib 300' or longer: \$1.50 additional to the group 1 rate. Crane operator with main boom and jib 400' or longer: \$3.00 additional to the group 1 rate.

PAID HOLIDAYS: New Year's Day, Memorial Day, Fourth of July, Labor Day, Thanksgiving Day and Christmas Day.

POWER EQUIPMENT OPERATOR CLASSIFICATIONS:

GROUP 1: Crane Operator with main boom & jib 400', 300', or 220' or longer.

GROUP 2: Crane Operator with main boom & jib 140' or longer, Tower Crane; Gantry Crane; Whirley Derrick.

GROUP 3: Regular Equipment Operator, Crane, Dozer, Loader, Hoist, Straddle Wagon, Mechanic, Grader and Hydro Excavator.

GROUP 4: Air Tugger (single drum), Material Hoist Pump 6" or over, Elevators, Brokk Concrete Breaker.

GROUP 5: Air Compressor, Welder, Generators, Conveyors

GROUP 6: Oiler and fire tender

ENGI0324-005 09/01/2025

AREA 1: GENESEE, LAPEER, LIVINGSTON, MACOMB, MONROE, OAKLAND, ST. CLAIR, WASHTENAW AND WAYNE COUNTIES

AREA 2: ALCONA, ALLEGAN, ALGER, ALPENA, ANTRIM, ARENAC, BARAGA, BARRY, BAY, BENZIE, BERRIEN, BRANCH, CALHOUN, CASS, CHARLEVOIX, CHEBOYGAN, CHIPPEWA, CLARE, CLINTON, CRAWFORD, DELTA, DICKINSON, EATON, EMMET, GLADWIN, GOGEBIC, GRAND TRAVERSE, GRATIOT, HILLSDALE, HOUGHTON, HURON, INGHAM, IONIA, IOSCO, IRON, ISABELLA, JACKSON, KALAMAZOO, KALKASKA, KENT, KWEENAW, LAKE, LEELANAU, LENAWEE, LUCE, MACKINAC, MANISTEE, MARQUETTE, MASON, MECOSTA, MENOMINEE, MIDLAND, MISSAUKEE, MONTCALM, MONTMORENCY, MUSKEGON, NEWAYGO, OCEANA, OGEMAW, ONTONAGON, OSCEOLA, OSCODA, OTSEGO, OTTAWA, PRESQUE ISLE, ROSCOMMON, SAGINAW, SANILAC, SCHOOLCRAFT, SHIAWASSEE, ST. JOSEPH, TUSCOLA, VAN BUREN AND WEXFORD COUNTIES

Rates Fringes

OPERATOR: Power Equipment
(Underground construction
(including sewer))

AREA 1:

GROUP 1.....	\$ 45.98	25.25
GROUP 2.....	\$ 41.25	25.25
GROUP 3.....	\$ 40.52	25.25
GROUP 4.....	\$ 39.95	25.25
GROUP 5.....	\$ 30.35	12.10

AREA 2:

GROUP 1.....	\$ 45.98	25.25
GROUP 2.....	\$ 41.25	25.25
GROUP 3.....	\$ 40.52	25.25
GROUP 4.....	\$ 39.95	25.25
GROUP 5.....	\$ 30.35	12.10

POWER EQUIPMENT OPERATOR CLASSIFICATIONS

GROUP 1: Backfiller tamper; Backhoe; Batch plant operator (concrete); Clamshell; Concrete paver (2 drums or larger); Conveyor loader (Euclid type); Crane (crawler, truck type or pile driving); Dozer; Dragline; Elevating grader; Endloader; Gradall (and similar type machine); Grader; Mechanic; Power shovel; Roller (asphalt); Scraper (self-propelled or tractor drawn); Side boom tractor (type D-4 or equivalent and larger); Slip form paver; Slope

paver; Trencher (over 8 ft. digging capacity); Well drilling rig; Concrete pump with boom operator; Hydro Excavator

GROUP 2: Boom truck (power swing type boom); Crusher; Hoist; Pump (1 or more - 6-in. discharge or larger - gas or diesel- powered or powered by generator of 300 amperes or more - inclusive of generator); Side boom tractor (smaller than type D-4 or equivalent); Tractor (pneu-tired, other than backhoe or front end loader); Trencher (8-ft. digging capacity and smaller); Vac Truck and End dump operator;

GROUP 3: Air compressors (600 cfm or larger); Air compressors (2 or more-less than 600 cfm); Boom truck (non-swinging, non- powered type boom); Concrete breaker (self-propelled or truck mounted - includes compressor); Concrete paver (1 drum-1/2 yd. or larger); Elevator (other than passenger); Maintenance person; Pump (2 or more-4-in. up to 6-in. discharge-gas or diesel powered - excluding submersible pumps); Pumpcrete machine (and similar equipment); Wagon drill (multiple); Welding machine or generator (2 or more-300 amp. or larger - gas or diesel powered)

GROUP 4: Boiler; Concrete saw (40 hp or over); Curing machine (self-propelled); Farm tractor (with attachment); Finishing machine (concrete); Hydraulic pipe pushing machine; Mulching equipment; Pumps (2 or more up to 4-in. discharge, if used 3 hours or more a day, gas or diesel powered - excluding submersible pumps); Roller (other than asphalt); Stump remover; Trencher (service); Vibrating compaction equipment, self-propelled (6 ft. wide or over); Sweeper (Wayne type); Water wagon and Extend-a boom forklift

Group 5: Fire Person, Oiler

* ENGI0324-006 06/01/2025

GENESEE, MACOMB, MONROE, OAKLAND, WASHTENAW, WAYNE, ALCONA, ALGER, ALLEGAN, ALPENA, ANTRIM, ARENAC, BARAGA, BARRY, BAY, BENZIE, BERRIEN, BRANCH, CALHOUN, CASS, CHARLEVOIX, CHEBOYGAN, CHIPPEWA, CLARE, CLINTON, CRAWFORD, DELTA, DICKINSON, EATON, EMMET, GLADWIN, GOGEBIC, GRAND TRAVERSE, GRATIOT, HILLSDALE, HOUGHTON, HURON, INGHAM, IONIA, IOSCO, IRON, ISABELLA, JACKSON, KALAMAZOO, KALKASKA, KENT, KEWEENAW, LAKE, LAPEER, LEELANAU, LENAWEE, LIVINGSTON, LUCE, MACKINAC, MANISTEE, MARQUETTE, MASON, MECOSTA, MENOMINEE, MIDLAND, MISSAUKEE, MONTCALM, MONTMORENCY, MUSKEGON, NEWAYGO, OCEANA, OGEMAW, ONTONAGON, OSCEOLA, OSCODA, OTSEGO, OTTAWA, PRESQUE ISLE, ROSCOMMON, SAGINAW, ST. CLARE, ST. JOSEPH, SANILAC, SCHOOLCRAFT, SHIAWASSEE, TUSCOLA, VAN BUREN AND WEXFORD COUNTIES

Rates Fringes

Power equipment operators:
(AIRPORT, BRIDGE & HIGHWAY CONSTRUCTION)

GROUP 1.....	\$ 46.21	25.25
GROUP 2.....	\$ 45.06	25.25
GROUP 3.....	\$ 38.33	25.25
GROUP 4.....	\$ 37.77	25.25

POWER EQUIPMENT OPERATOR CLASSIFICATIONS

GROUP 1: Paver Operator (5 bags or more); Slip Form Paver; Asphalt Paver (self propelled); Shovel (Excavator) installing utilities over 20 feet in depth.

Group 2: Asphalt plant operator; crane operator (does not include work on bridge construction projects when the crane operator is erecting structural components); Dragline operator; Shovel (Excavator) operator; Locomotive operator; Elevating grader operator; Pile driving operator; Roller operator (asphalt); Blade grader operator; Trenching machine operator (ladder or wheel type); Auto-grader; Self-propelled or tractor-drawn scraper; Conveyor loader operator (Euclid type); Bulldozer; Hoisting engineer; Tractor operator; Finishing machine operator (asphalt); Mechanic; Pump operator (6-in. discharge or over, gas, diesel powered or generator of 300 amp. or larger); Shouldering or gravel distributing machine operator (self-propelled); Backhoe (with over 3/8 yd. bucket); Side boom tractor (type D-4 or equivalent or larger); Tube finisher (slip form paving); Gradall (and similar type machine); Asphalt planner (self-propelled); Batch plant (concrete-central mix); Slurry machine (asphalt); Concrete pump (3 in. and over); Roto-mill; Swinging boom truck (over 12 ton capacity); Hydro demolisher (water blaster); Farm-type tractor with attached pan; Vacuum truck operator; Batch Plant (concrete dry batch); Concrete Saw Operator (40h.p. or over; Tractor Operator (farm type); Finishing Machine Operator (concrete); Grader Operator (self-propelled fine grade or form (concrete); tractor operator (farm type with attachment); Wagon Drill operator; Boom or winch hoist truck operator.

GROUP 3: Screening plant operator; Washing plant operator; Crusher operator; Backhoe (with 3/8 yd. bucket or less); Side boom tractor (smaller than D-4 type or equivalent); Sweeper (Wayne type and similar equipment); Greese Truck; Air Compressor Operator (600 cu.ft. per min or more); Air Compressor Operator (two or more, less than 600 cfm); End Loader operator (1 yard Capacity and over); Side boom tractor (type D or equivalent or larger; Endloader operator *under 1 yard capacity; Trencher (service).

GROUP 4: Boiler fire tender; Concrete Breaker; Oiler; Fire tender; Trencher (service); Flexplane operator; Cleftplane operator; Roller operator (other than asphalt); Curing equipment operator (self-propelled); Power bin operator; Plant drier operator (asphalt); Vibratory compaction equipment operator (6 ft. wide or over); Guard post driver operator (power driven); All mulching equipment; Stump remover; Concrete pump (under 3-in.); Mesh installer (self-propelled); End dump; Skid steer.

ENGI0324-007 05/01/2025

ALGER, BARAGA, CHIPPEWA, DELTA, DICKINSON, GOGEBIC, HOUGHTON, IRON, KEWEENAW, LUCE, MACKINAC MARQUETTE, MENOMINEE, ONTONAGON AND SCHOOLCRAFT COUNTIES:

Rates Fringes

OPERATOR: Power Equipment
(Steel Erection)
Compressor, welder and

forklift.....	\$ 43.30	25.00
Crane operator, main boom & jib 120' or longer.....	\$ 49.77	25.00
Crane operator, main boom & jib 140' or longer.....	\$ 50.07	24.60
Crane operator, main boom & jib 220' or longer.....	\$ 50.66	25.00
Mechanic with truck and tools.....	\$ 48.90	25.00
Oiler and fireman.....	\$ 41.76	25.00
Regular operator.....	\$ 47.12	25.00

 ENGI0324-008 10/01/2023

ALCONA, ALGER, ALLEGAN, ALPENA, ANTRIM, ARENAC, BARAGA, BARRY,
 BAY, BENZIE, BERRIEN, BRANCH, CALHOUN, CASS, CHARLEVOIX,
 CHEBOYGAN, CHIPPEWA, CLARE, CLINTON, CRAWFORD, DELTA,
 DICKINSON, EATON, EMMET, GENESEE, GLADWIN, GOGEBIC, GRAND
 TRAVERSE, GRATIOT, HILLSDALE, HOUGHTON, HURON, INGHAM, IONIA,
 IOSCO, IRON, ISABELLA, JACKSON, KALAMAZOO, KALKASKA, KENT,
 KEWEENAW, LAKE, LAPEER, LEELANAU, LENAWEE, LIVINGSTON, LUCE,
 MACKINAC, MACOMB, MANISTEE, MARQUETTE, MASON, MECOSTA,
 MENOMINEE, MIDLAND, MISSAUKEE, MONTCALM, MONTMORENCY, MONROE,
 MUSKEGON, NEWAYGO, OAKLAND, OCEANA, OGEMAW, ONTONAGON, OSCEOLA,
 OSCODA, OTSEGO, OTTAWA, PRESQUE ISLE, ROSCOMMON, SAGINAW, ST.
 CLARE, ST. JOSEPH, SANILAC, SCHOOLCRAFT, SHIAWASSEE, TUSCOLA,
 VAN BUREN, WASHTENAW, WAYNE AND WEXFORD COUNTIES

Rates Fringes

OPERATOR: Power Equipment
 (Sewer Relining)

GROUP 1.....	\$ 37.37	15.44
GROUP 2.....	\$ 35.33	15.44

SEWER RELINING CLASSIFICATIONS

GROUP 1: Operation of audio-visual closed circuit TV system,
 including remote in-ground cutter and other equipment used
 in connection with the CCTV system

GROUP 2: Operation of hot water heaters and circulation
 systems, water jettors and vacuum and mechanical debris
 removal systems

 ENGI0325-012 05/01/2025

Rates Fringes

Power equipment operators -
 gas distribution and duct
 installation work:

GROUP 1.....	\$ 39.78	25.25
GROUP 2.....	\$ 36.05	25.25

SCOPE OF WORK: The construction, installation, treating and
 reconditioning of pipelines transporting gas vapors within
 cities, towns, subdivisions, suburban areas, or within
 private property boundaries, up to and including private
 meter settings of private industrial, governmental or other
 premises, more commonly referred to as ""distribution work,""
 starting from the first metering station, connection,
 similar or related facility, of the main or cross country

pipeline and including duct installation.

Group 1: Backhoe, crane, grader, mechanic, dozer (D-6 equivalent or larger), side boom (D-4 equivalent or larger), trencher(except service), endloader (2 yd. capacity or greater).

GROUP 2: Dozer (less than D-6 equivalent), endloader (under 2 yd. capacity), side boom (under D-4 capacity), backfiller, pumps (1 or 2 of 6-inch discharge or greater), boom truck (with powered boom), tractor (wheel type other than backhoe or front endloader). Tamper (self-propelled), boom truck (with non-powered boom), concrete saw (20 hp or larger), pumps (2 to 4 under 6-inch discharge), compressor (2 or more or when one is used continuously into the second day) and trencher(service). Oiler, hydraulic pipe pushing machine, grease person and hydrostatic testing operator.

IRON0008-007 06/01/2024

ALGER, BARAGA, CHIPPEWA, DELTA, DICKINSON, GOGEBIC, HOUGHTON, IRON, KEWEENAW, LUCE, MACKINAC MARQUETTE, MENOMINEE, ONTONAGON AND SCHOOLCRAFT COUNTIES:

	Rates	Fringes
Ironworker - pre-engineered metal building erector.....	\$ 23.70	6.95
IRONWORKER		
General contracts \$10,000,000 or greater.....	\$ 39.91	32.32
General contracts less than \$10,000,000.....	\$ 39.91	32.32

Paid Holidays: New Year's Day, Memorial Day, July 4th, Labor Day, Thanksgiving Day & Christmas Day.

IRON0025-002 06/01/2025

ALCONA, ALPENA, ARENAC, BAY, CHEBOYGAN, CLARE, CLINTON, CRAWFORD, GENESEE, GLADWIN, GRATIOT, HURON, INGHAM, IOSCO, ISABELLA, JACKSON, LAPEER, LIVINGSTON, MACOMB, MIDLAND, MONTMORENCY, OAKLAND, OGEMAW, OSCODA, OTSEGO, PRESQUE ISLE, ROSCOMMON, SAGINAW, SANILAC, SHIAWASSEE, ST. CLAIR, TUSCOLA, WASHTENAW AND WAYNE COUNTIES:

	Rates	Fringes
Ironworker - pre-engineered metal building erector		
ALLEGAN, ANTRIM, BARRY, BENZIE, BRANCH, CALHOUN, CHARLEVOIX, EATON, EMMET, GRAND TRAVERSE, HILLSDALE, IONIA, KALAMAZOO, KALKASKA, KENT, LAKE, LEELANAU, MANISTEE, MASON, MECOSTA, MISSAUKEE, MONTCALM, MUSKEGON, NEWAYGO, OCEANA, OSCEOLA, OTTAWA, ST. JOSEPH, VAN		

BUREN AND WEXFORD COUNTIES:.\$ 28.80	27.43
Bay, Genesee, Lapeer, Livingston (east of Burkhardt Road), Macomb, Midland, Oakland, Saginaw, St. Clair, The University of Michigan, Washtenaw (east of U.S. 23) & Wayne...\$ 30.02	28.13
IRONWORKER	
Ornamental and Structural...\$ 36.55	35.93
Reinforcing.....\$ 36.55	32.87

IRON0055-005 07/01/2022

LENAWEE AND MONROE COUNTIES:

	Rates	Fringes
IRONWORKER		
Pre-engineered metal buildings.....\$ 23.59		19.35
All other work.....\$ 33.00		27.20

IRON0292-003 06/01/2020

BERRIEN AND CASS COUNTIES:

	Rates	Fringes
IRONWORKER (Including pre-engineered metal building erector).....\$ 31.75		22.84

LAB00005-006 10/01/2022

	Rates	Fringes
Laborers - hazardous waste abatement: (ALCONA, ALPENA, ANTRIM, BENZIE, CHARLEVOIX, CHEBOYGAN, CRAWFORD, EMMET, GRAND TRAVERSE, IOSCO, KALKASKA, LEELANAU, MISSAUKEE, MONTMORENCY, OSCODA, OTSEGO, PRESQUE ISLE AND WEXFORD COUNTIES - Zone 10)		
Levels A, B or C.....\$ 17.45		12.75
class b.....\$ 18.64		12.90
Work performed in conjunction with site preparation not requiring the use of personal protective equipment; Also, Level D.....\$ 16.45		12.75
class a.....\$ 17.64		12.90

Zone 10

Laborers - hazardous waste
abatement: (ALGER, BARAGA,
CHIPPEWA, DELTA, DICKINSON,
GOGEBIC, HOUGHTON, IRON,
KEWEENAW, LUCE, MACKINAC,
MARQUETTE, MENOMINEE,
ONTONAGON AND SCHOOLCRAFT
COUNTIES - Zone 11)

Levels A, B or C.....\$ 25.18	12.90
Work performed in conjunction with site preparation not requiring the use of personal protective equipment;	
Also, Level D.....\$ 22.58	12.90
Laborers - hazardous waste abatement: (ALLEGAN, BARRY, BERRIEN, BRANCH, CALHOUN, CASS, IONIA COUNTY (except the city of Portland); KALAMAZOO, KENT, LAKE, MANISTEE, MASON, MECOSTA, MONTCALM, MUSKEGON, NEWAYGO, OCEANA, OSCEOLA, OTTAWA, ST. JOSEPH AND VAN BUREN COUNTIES - Zone 9)	
Levels A, B or C.....\$ 21.88	13.26
Work performed in conjunction with site preparation not requiring the use of personal protective equipment;	
Also, Level D.....\$ 20.80	12.90
Laborers - hazardous waste abatement: (ARENAC, BAY, CLARE, GLADWIN, GRATIOT, HURON, ISABELLA, MIDLAND, OGEAW, ROSCOMMON, SAGINAW AND TUSCOLA COUNTIES - Zone 8)	
Levels A, B or C.....\$ 23.74	12.95
Work performed in conjunction with site preparation not requiring the use of personal protective equipment;	
Also, Level D.....\$ 20.80	12.90
Laborers - hazardous waste abatement: (CLINTON, EATON AND INGHAM COUNTIES; IONIA COUNTY (City of Portland); LIVINGSTON COUNTY (west of Oak Grove Rd., including the City of Howell) - Zone 6)	
Levels A, B or C.....\$ 26.33	12.95
Work performed in conjunction with site preparation not requiring the use of personal protective equipment;	
Also, Level D.....\$ 24.64	12.90
Laborers - hazardous waste abatement: (GENESEE, LAPEER AND SHIAWASSEE COUNTIES - Zone 7)	
Levels A, B or C.....\$ 24.20	13.80
Work performed in conjunction with site preparation not requiring the use of personal protective equipment;	
Also, Level D.....\$ 23.20	13.80
Laborers - hazardous waste abatement: (HILLSDALE,	

JACKSON AND LENAWEE COUNTIES

- Zone 4)

Levels A, B or C.....\$ 27.13	14.95
Work performed in conjunction with site preparation not requiring the use of personal protective equipment;	
Also, Level D.....\$ 24.17	12.90

Laborers - hazardous waste abatement: (LIVINGSTON COUNTY (east of Oak Grove Rd. and south of M-59, excluding the city of Howell); AND

WASHTENAW COUNTY - Zone 3)

Levels A, B or C.....\$ 29.93	14.20
Work performed in conjunction with site preparation not requiring the use of personal protective equipment;	
Also, Level D.....\$ 28.93	14.20

Laborers - hazardous waste abatement: (MACOMB AND WAYNE COUNTIES - Zone 1)

Levels A, B or C.....\$ 29.93	16.90
Work performed in conjunction with site preparation not requiring the use of personal protective equipment;	
Also, Level D.....\$ 28.93	16.90

Laborers - hazardous waste abatement: (MONROE COUNTY - Zone 4)

Levels A, B or C.....\$ 31.75	14.90
Work performed in conjunction with site preparation not requiring the use of personal protective equipment;	
Also, Level D.....\$ 31.75	14.90

Laborers - hazardous waste abatement: (OAKLAND COUNTY and the Northeast portion of LIVINGSTON COUNTY bordered by Oak Grove Road on the West and M-59 on the South - Zone

2)

Level A, B, C.....\$ 29.93	16.90
Work performed in conjunction with site preparation not requiring the use of personal protective equipment;	
Also, Level D.....\$ 28.93	16.90

Laborers - hazardous waste abatement: (SANILAC AND ST. CLAIR COUNTIES - Zone 5)

Levels A, B or C.....\$ 26.21	16.62
Work performed in conjunction with site preparation not requiring the use of personal protective equipment;	

Also, Level D.....\$ 24.75 16.35

LAB00259-001 09/01/2025

AREA 1: MACOMB, OAKLAND AND WAYNE COUNTIES
AREA 2: ALCONA, ALGER, ALLEGAN, ALPENA, ANTRIM, ARENAC, BARAGA, BARRY, BAY, BENZIE, BERRIEN, BRANCH, CALHOUN, CASS, CHARLEVOIX, CHEBOYGAN, CHIPPEWA, CLARE, CLINTON, CRAWFORD, DELTA, DICKINSON, EATON, EMMET, GENESEE, GLADWIN, GOGEBIC, GRAND TRAVERSE, GRATIOT, HILLSDALE, HOUGHTON, HURON, INGHAM, IONIA, IOSCO, IRON, ISABELLA, JACKSON, KALAMAZOO, KALKASKA, KENT, KEWEENAW, LAKE, LAPEER, LEELANAU, LENAWEE, LIVINGSTON, LUCE, MACKINAC, MANISTEE, MARQUETTE, MASON, MECOSTA, MENOMINEE, MIDLAND, MISSAUKEE, MONROE, MONTCALM, MONTMORENCY, MUSKEGON, NEWAYGO, OCEANA, OGEMAW, ONTONAGON, OSCEOLA, OSCODA, OTSEGO, OTTAWA, PRESQUE ISLE, ROSCOMMON, SAGINAW, ST. CLARE, ST. JOSEPH, SANILAC, SCHOOLCRAFT, SHIAWASSEE, TUSCOLA, VAN BUREN, WASHTENAW AND WEXFORD COUNTIES

Rates Fringes

Laborers - tunnel, shaft and caisson:

Table with 3 columns: Group, Rate, Fringe. Includes Area 1 (Groups 1-7) and Area 2 (Groups 1-7) with corresponding rates and fringe values.

SCOPE OF WORK: Tunnel, shaft and caisson work of every type and description and all operations incidental thereto, including, but not limited to, shafts and tunnels for sewers, water, subways, transportation, diversion, sewerage, caverns, shelters, aquifers, reservoirs, missile silos and steel sheeting for underground construction.

TUNNEL LABORER CLASSIFICATIONS

GROUP 1: Tunnel, shaft and caisson laborer, dump, shanty, hog house tender, testing (on gas) and watchman

GROUP 2: Manhole, headwall, catch basin builder, bricklayer tender, mortar machine and material mixer

GROUP 3: Air tool operator (jackhammer, bush hammer and grinder), first bottom, second bottom, cage tender, car pusher, carrier, concrete, concrete form, concrete repair, cement invert laborer, cement finisher, concrete shoveler, conveyor, floor, gasoline and electric tool operator, gunite, grout operator, welder, heading dinky person, inside lock tender, pea gravel operator, pump, outside lock tender, scaffold, top signal person, switch person, track, tugger, utility person, vibrator, winch operator, pipe

jacking, wagon drill and air track operator and concrete saw operator (under 40 h.p.)

GROUP 4: Tunnel, shaft and caisson mucker, bracer, liner plate, long haul dinky driver and well point

GROUP 5: Tunnel, shaft and caisson miner, drill runner, key board operator, power knife operator, reinforced steel or mesh (e.g. wire mesh, steel mats, dowel bars, etc.)

GROUP 6: Dynamite and powder

GROUP 7: Restoration laborer, seeding, sodding, planting, cutting, mulching and top soil grading; and the restoration of property such as replacing mailboxes, wood chips, planter boxes, flagstones, etc.

LAB00334-001 09/01/2025

	Rates	Fringes
Laborers - open cut:		
ZONE 1 - MACOMB, OAKLAND AND WAYNE COUNTIES:		
GROUP 1.....	\$ 29.98	22.75
GROUP 2.....	\$ 31.98	22.75
GROUP 3.....	\$ 28.14	22.75
GROUP 4.....	\$ 23.71	16.72
GROUP 5.....	\$ 24.17	16.72
GROUP 6.....	\$ 22.00	16.72
GROUP 7.....	\$ 17.84	16.72
ZONE 2 - LIVINGSTON COUNTY (east of M-151 (Oak Grove Rd.)); MONROE AND WASHTENAW COUNTIES:		
GROUP 1.....	\$ 32.10	17.45
GROUP 2.....	\$ 34.10	17.45
GROUP 3.....	\$ 30.10	17.45
GROUP 4.....	\$ 25.10	16.72
GROUP 5.....	\$ 25.25	16.72
GROUP 6.....	\$ 22.55	16.72
GROUP 7.....	\$ 22.11	16.72
ZONE 3 - CLINTON, EATON, GENESEE, HILLSDALE AND INGHAM COUNTIES; IONIA COUNTY (City of Portland); JACKSON, LAPEER AND LENAWEЕ COUNTIES; LIVINGSTON COUNTY (west of M-151 Oak Grove Rd.); SANILAC, ST. CLAIR AND SHIAWASSEE COUNTIES:		
GROUP 1.....	\$ 30.29	17.45
GROUP 2.....	\$ 32.29	17.45
GROUP 3.....	\$ 28.29	17.45
GROUP 4.....	\$ 23.30	16.72
GROUP 5.....	\$ 23.44	16.72
GROUP 6.....	\$ 20.74	16.72
GROUP 7.....	\$ 22.23	16.72
ZONE 4 - ALCONA, ALLEGAN, ALPENA, ANTRIM, ARENAC, BARRY, BAY, BENZIE, BERRIEN, BRANCH, CALHOUN, CASS, CHARLEVOIX,		

CHEBOYGAN, CLARE,
 CRAWFORD, EMMET,
 GLADWIN, GRAND TRAVERSE,
 GRATIOT AND HURON
 COUNTIES; IONIA COUNTY
 (EXCEPT THE CITY OF
 PORTLAND); IOSCO,
 ISABELLA, KALAMAZOO,
 KALKASKA, KENT,
 LAKE, LEELANAU, MANISTEE,
 MASON, MECOSTA, MIDLAND,
 MISSAUKEE, MONTCALM,
 MONTMORENCY, MUSKEGON,
 NEWAYGO, OCEANA, OGEMAW,
 OSCEOLA, OSCODA, OTSEGO,
 OTTAWA, PRESQUE ISLE,
 ROSCOMMON, SAGINAW, ST.
 JOSEPH, TUSCOLA, VAN BUREN
 AND WEXFORD COUNTIES:

GROUP 1.....	\$ 28.72	18.45
GROUP 2.....	\$ 30.72	18.45
GROUP 3.....	\$ 26.72	18.45
GROUP 4.....	\$ 22.33	16.72
GROUP 5.....	\$ 22.45	16.72
GROUP 6.....	\$ 19.67	16.72
GROUP 7.....	\$ 22.30	16.72

ZONE 5 - ALGER, BARAGA,
 CHIPPEWA, DELTA,
 DICKINSON, GOGEBIC,
 HOUGHTON, IRON,
 KEWEENAW, LUCE, MACKINAC,
 MARQUETTE, MENOMINEE,
 ONTONAGON AND SCHOOLCRAFT
 COUNTIES:

GROUP 1.....	\$ 29.98	22.75
GROUP 2.....	\$ 30.09	19.45
GROUP 3.....	\$ 26.09	19.45
GROUP 4.....	\$ 22.56	16.72
GROUP 5.....	\$ 22.64	16.72
GROUP 6.....	\$ 19.99	16.72
GROUP 7.....	\$ 22.45	16.72

SCOPE OF WORK:

Open cut construction work shall be construed to mean work which requires the excavation of earth including industrial, commercial and residential building site excavation and preparation, land balancing, demolition and removal of concrete and underground appurtenances, grading, paving, sewers, utilities and improvements; retention, oxidation, flocculation and irrigation facilities, and also including but not limited to underground piping, conduits, steel sheeting for underground construction, and all work incidental thereto, and general excavation. For all areas except the Upper Peninsula, open cut construction work shall also be construed to mean waterfront work, piers, docks, seawalls, breakwalls, marinas and all incidental work. Open cut construction work shall not include any structural modifications, alterations, additions and repairs to buildings, or highway work, including roads, streets, bridge construction and parking lots or steel erection work and excavation for the building itself and back filling inside of and within 5 ft. of the building and foundations, footings and piers for the building. Open cut construction work shall not include any work covered under

Tunnel, Shaft and Caisson work.

OPEN CUT LABORER CLASSIFICATIONS

GROUP 1: Construction laborer

GROUP 2: Mortar and material mixer, concrete form person, signal person, well point person, manhole, headwall and catch basin builder, headwall, seawall, breakwall and dock builder

GROUP 3: Air, gasoline and electric tool operator, vibrator operator, driller, pump person, tar kettle operator, bracer, rodder, reinforced steel or mesh person (e.g., wire mesh, steel mats, dowel bars, etc.), welder, pipe jacking and boring person, wagon drill and air track operator and concrete saw operator (under 40 h.p.), windlass and tugger person and directional boring person

GROUP 4: Trench or excavating grade person

GROUP 5: Pipe layer (including crock, metal pipe, multi-plate or other conduits)

GROUP 6: Grouting man, audio-visual television operations and all other operations in connection with closed circuit television inspection, pipe cleaning and pipe relining work and the installation and repair of water service pipe and appurtenances

GROUP 7: Restoration laborer, seeding, sodding, planting, cutting, mulching and top soil grading; and the restoration of property such as replacing mailboxes, wood chips, planter boxes, flagstones, etc.

LAB00465-001 06/01/2025

LABORER: Highway, Bridge and Airport Construction

AREA 1: GENESEE, MACOMB, MONROE, OAKLAND, WASHTENAW AND WAYNE COUNTIES

AREA 2: ALLEGAN, BARRY, BAY, BERRIEN, BRANCH, CALHOUN, CASS, CLINTON, EATON, GRATIOT, HILLSDALE, HURON, INGHAM, JACKSON, KALAMAZOO, LAPEER, LENAWEE, LIVINGSTON, MIDLAND, MUSKEGON, SAGINAW, SANILAC, SHIAWASSEE, ST. CLAIR, ST. JOSEPH, TUSCOLA AND VAN BUREN COUNTIES

AREA 3: ALCONA, ALPENA, ANTRIM, ARENAC, BENZIE, CHARLEVOIX, CHEBOYGAN, CLARE, CRAWFORD, EMMET, GLADWIN, GRAND TRAVERSE, IONIA, IOSCO, ISABELLA, KALKASKA, KENT, LAKE, LEELANAU, MANISTEE, MASON, MECOSTA, MISSAUKEE, MONTCALM, MONTMORENCY, NEWAYGO, OCEANA, OGEMAW, OSCEOLA, OSCODA, OTSEGO, OTTAWA, PRESQUE ISLE, ROSCOMMON AND WEXFORD COUNTIES

AREA 4: ALGER, BARAGA, CHIPPEWA, DELTA, DICKINSON, GOGEBIC, HOUGHTON, IRON, KEWEENAW, LUCE, MACKINAC, MARQUETTE, MENOMINEE, ONTONAGON AND SCHOOLCRAFT COUNTIES

	Rates	Fringes
LABORER (AREA 1)		
GROUP 1.....	\$ 35.51	14.45

GROUP 2.....	\$ 31.96	14.45
GROUP 3.....	\$ 35.82	14.45
GROUP 4.....	\$ 35.90	14.45
GROUP 5.....	\$ 36.11	14.45
GROUP 6.....	\$ 36.41	14.45
LABORER (AREA 2)		
GROUP 1.....	\$ 33.37	14.45
GROUP 2.....	\$ 30.03	14.45
GROUP 3.....	\$ 33.81	14.45
GROUP 4.....	\$ 34.16	14.45
GROUP 5.....	\$ 34.03	14.45
GROUP 6.....	\$ 34.37	14.45
LABORER (AREA 3)		
GROUP 1.....	\$ 32.62	14.45
GROUP 2.....	\$ 33.83	14.45
GROUP 3.....	\$ 33.12	14.45
GROUP 4.....	\$ 33.56	14.45
GROUP 5.....	\$ 33.18	14.45
GROUP 6.....	\$ 33.61	14.45
LABORER (AREA 4)		
GROUP 1.....	\$ 33.52	13.45
GROUP 2.....	\$ 33.73	13.45
GROUP 3.....	\$ 34.02	13.45
GROUP 4.....	\$ 34.46	13.45
GROUP 5.....	\$ 34.08	13.45
GROUP 6.....	\$ 34.51	13.45

LABORER CLASSIFICATIONS

GROUP 1: Asphalt shoveler or loader; asphalt plant misc.; burlap person; yard person; dumper (wagon, truck, etc.); joint filling laborer; miscellaneous laborer; unskilled laborer; sprinkler laborer; form setting laborer; form stripper; pavement reinforcing; handling and placing (e.g., wire mesh, steel mats, dowel bars); mason's tender or bricklayer's tender on manholes; manhole builder; headwalls, etc.; waterproofing, (other than buildings) seal coating and slurry mix, shoring, underpinning; pressure grouting; bridge pin and hanger removal; material recycling laborer; horizontal paver laborer (brick, concrete, clay, stone and asphalt); ground stabilization and modification laborer; grouting; waterblasting; top person; railroad track and trestle laborer; carpenters' tender; guard rail builders' tender; earth retention barrier and wall and M.S.E. wall installer's tender; highway and median installer's tender (including sound, retaining, and crash barriers); fence erector's tender; asphalt raker tender; sign installer; remote control operated equipment.

GROUP 2: Mixer operator (less than 5 sacks); air or electric tool operator (jackhammer, etc.); spreader; boxperson (asphalt, stone, gravel); concrete paddler; power chain saw operator; paving batch truck dumper; tunnel mucker (highway work only); concrete saw (under 40 h.p.) and dry pack machine; roto-mill grounds person.

GROUP 3: Tunnel miner (highway work only); finishers tenders; guard rail builders; highway and median barrier installer; earth retention barrier and wall and M.S.E. wall installer's (including sound, retaining and crash barriers); fence erector; bottom person; powder person; wagon drill and air track operator; diamond and core drills; grade checker; certified welders; curb and side rail setter's tender.

GROUP 4: Asphalt raker

GROUP 5: Pipe layers, oxy-gun

GROUP 6: Line-form setter for curb or pavement; asphalt screed checker/screw man on asphalt paving machines.

LAB01076-005 04/01/2025

MICHIGAN STATEWIDE

	Rates	Fringes
LABORER (DISTRIBUTION WORK)		
Zone 1.....	\$ 28.41	13.45
Zone 2.....	\$ 24.55	13.45
Zone 3.....	\$ 23.55	13.45
Zone 4.....	\$ 22.92	13.45
Zone 5.....	\$ 22.95	13.45

DISTRIBUTION WORK - The construction, installation, treating and reconditioning of distribution pipelines transporting coal, oil, gas or other similar materials, vapors or liquids, including pipelines within private property boundaries, up to and including the meter settings on residential, commercial, industrial, institutional, private and public structures. All work covering pumping stations and tank farms not covered by the Building Trades Agreement. Other distribution lines with the exception of sewer, water and cable television are included.

Underground Duct Layer Pay: \$.40 per hour above the base pay rate.

Zone 1 - Macomb, Oakland and Wayne

Zone 2 - Monroe and Washtenaw

Zone 3 - Bay, Genesee, Lapeer, Midland, Saginaw, Sanilac, Shiawassee and St. Clair

Zone 4 - Alger, Baraga, Chippewa, Delta, Dickinson, Gogebic, Houghton, Iron, Keweenaw, Luce, Mackinac, Marquette, Menominee, Ontonagon and Schoolcraft

Zone 5 - Remaining Counties in Michigan

PAIN0022-002 07/01/2008

HILLSDALE, JACKSON AND LENAWE COUNTY; LIVINGSTON COUNTY (east of the eastern city limits of Howell, not including the city of Howell, north to the Genesee County line and south to the Washtenaw County line); MACOMB, MONROE, OAKLAND, WASHTENAW AND WAYNE COUNTIES:

	Rates	Fringes
PAINTER.....	\$ 25.06	14.75

FOOTNOTES: For all spray work and journeyman rigging for spray work, also blowing off, \$0.80 per hour additional (applies only to workers doing rigging for spray work on off the floor work. Does not include setting up or moving rigging on floor surfaces, nor does it apply to workers engaged in covering up or tending spray equipment. For all sandblasting and spray work performed on highway bridges,

overpasses, tanks or steel, \$0.80 per hour additional. For all brushing, cleaning and other preparatory work (other than spraying or steeplejack work) at scaffold heights of fifty (50) feet from the ground or higher, \$0.50 per hour additional. For all preparatorial work and painting performed on open steel under forty (40) feet when no scaffolding is involved, \$0.50 per hour additional. For all swing stage work-window jacks and window belts-exterior and interior, \$0.50 per hour additional. For all spray work and sandblaster work to a scaffold height of forty (40) feet above the floor level, \$0.80 per hour additional. For all preparatorial work and painting on all highway bridges or overpasses up to forty (40) feet in height, \$0.50 per hour additional. For all steeplejack work performed where the elevation is forty (40) feet or more, \$1.25 per hour additional.

 PAIN0312-001 06/01/2018

EXCLUDES: ALLEGAN COUNTY (Townships of Dorr, Fillmore, Heath, Hopkins, Laketown, Leighton, Manlius, Monterey, Overisel, Salem, Saugatuck and Wayland); INCLUDES: Barry, Berrien, Branch, Calhoun, Cass, Hillsdale, Kalamazoo, St. Joseph, Van Buren

	Rates	Fringes
PAINTER		
Brush and roller.....	\$ 23.74	13.35
Spray, Sandblast, Sign		
Painting.....	\$ 24.94	13.35

 PAIN0845-003 05/10/2018

CLINTON COUNTY; EATON COUNTY (does not include the townships of Bellevue and Olivet); INGHAM COUNTY; IONIA COUNTY (east of Hwy. M 66); LIVINGSTON COUNTY (west of the eastern city limits of Howell, including the city of Howell, north to the Genesee County line and south to the Washtenaw County line); AND SHIAWASSEE COUNTY (Townships of Bennington, Laingsbury and Perry):

	Rates	Fringes
PAINTER.....	\$ 25.49	13.74

 PAIN0845-015 05/10/2018

MUSKEGON COUNTY; NEWAYGO COUNTY (except the Townships of Barton, Big Prairie, Brooks, Croton, Ensley, Everett, Goodwell, Grant, Home, Monroe, Norwich and Wilcox); OCEANA COUNTY; OTTAWA COUNTY (except the townships of Allendale, Blendone, Chester, Georgetown, Holland, Jamestown, Olive, Park, Polkton, Port Sheldon, Tallmadge, Wright and Zeeland):

	Rates	Fringes
PAINTER.....	\$ 25.49	13.74

 PAIN0845-018 05/10/2018

ALLEGAN COUNTY (Townships of Dorr, Fillmore, Heath, Hopkins, Laketown, Leighton, Manlius, Monterey, Overisel, Salem, Saugatuck and Wayland); IONIA COUNTY (west of Hwy. M-66); KENT, MECOSTA AND MONTCALM COUNTIES; NEWAYGO COUNTY (Townships of Barton, Big Prairie, Brooks, Croton, Ensley, Everett, Goodwell, Grant, Home, Monroe, Norwich and Wilcox); OSCEOLA COUNTY (south of Hwy. #10); OTTAWA COUNTY (Townships of Allendale, Blendone, Chester, Georgetown, Holland, Jamestown, Olive, Park, Polkton, Port Sheldon, Tallmadge, Wright and Zeeland):

	Rates	Fringes
PAINTER.....	\$ 25.49	13.74

FOOTNOTES: Lead abatement work: \$1.00 per hour additional.

PAIN1011-003 06/02/2022

ALGER, BARAGA, CHIPPEWA, DELTA, DICKINSON, GOGEBIC, HOUGHTON, IRON, KEWEENAW, LUCE, MACKINAC, MARQUETTE, MENOMINEE, ONTONAGON AND SCHOOLCRAFT COUNTIES:

	Rates	Fringes
PAINTER.....	\$ 24.66	14.99

FOOTNOTES: High pay (bridges, overpasses, watertower): 30 to 80 ft.: \$.65 per hour additional. 80 ft. and over: \$1.30 per hour additional.

PAIN1474-002 06/01/2010

HURON COUNTY; LAPEER COUNTY (east of Hwy. M-53); ST. CLAIR, SANILAC AND TUSCOLA COUNTIES:

	Rates	Fringes
PAINTER.....	\$ 23.79	12.02

FOOTNOTES: Lead abatement work: \$1.00 per hour additional. Work with any hazardous material: \$1.00 per hour additional. Sandblasting, steam cleaning and acid cleaning: \$1.00 per hour additional. Ladder work at or above 40 ft., scaffold work at or above 40 ft., swing stage, boatswain chair, window jacks and all work performed over a falling height of 40 ft.: \$1.00 per hour additional. Spray gun work, pick pullers and those handling needles, blowing off by air pressure, and any person rigging (setting up and moving off the ground): \$1.00 per hour additional. Steeplejack, tanks, gas holders, stacks, flag poles, radio towers and beacons, power line towers, bridges, etc.: \$1.00 per hour additional, paid from the ground up.

PAIN1803-003 06/01/2025

ALCONA, ALPENA, ANTRIM, ARENAC, BAY, BENZIE, CHARLEVOIX, CHEBOYGAN, CLARE, CRAWFORD, EMMET, GLADWIN, GRAND TRAVERSE, GRATIOT, IOSCO, ISABELLA, KALKASKA, LAKE, LEELANAU, MANISTEE, MASON, MIDLAND, MISSAUKEE, MONTMORENCY AND OGEMAW COUNTIES; OSCEOLA COUNTY (north of Hwy. #10); OSCODA, OTSEGO, PRESQUE

ISLE, ROSCOMMON, SAGINAW AND WEXFORD COUNTIES:

	Rates	Fringes
PAINTER		
Work performed on water, bridges over water or moving traffic, radio and powerline towers, elevated tanks, steeples, smoke stacks over 40 ft. of falling heights, recovery of lead-based paints and any work associated with industrial plants, except maintenance of industrial plants.....	\$ 29.23	19.11
All other work, including maintenance of industrial plant.....	\$ 29.35	19.05

FOOTNOTES: Spray painting, sandblasting, blowdown associated with spraying and blasting, water blasting and work involving a swing stage, boatswain chair or spider: \$1.00 per hour additional. All work performed inside tanks, vessels, tank trailers, railroad cars, sewers, smoke stacks, boilers or other spaces having limited egress not including buildings, opentop tanks, pits, etc.: \$1.25 per hour additional.

 PLAS0514-001 06/01/2023

ZONE 1: GENESEE, LIVINGSTON, MACOMB, MONROE, OAKLAND, SAGINAW, WASHTENAW AND WAYNE COUNTIES

ZONE 2: ALCONA, ALGER, ALLEGAN, ALPENA, ANTRIM, ARENAC, BARAGA, BARRY, BAY, BENZIE, BERRIEN, BRANCH, CALHOUN, CASS, CHARLEVOIX, CHEBOYGAN, CHIPPEWA, CLARE, CLINTON, CRAWFORD, DELTA, DICKINSON, EATON, EMMET, GLADWIN, GOGEBIC, GRAND TRAVERSE, GRATIOT, HILLSDALE, HOUGHTON, HURON, INGHAM, IONIA, IOSCO, IRON, ISABELLA, JACKSON, KALAMAZOO, KALKASKA, KENT, KEWEENAW, LAKE, LAPEER, LEELANAU, LENAWEE, LUCE, MACKINAC, MANISTEE, MARQUETTE, MASON, MECOSTA, MENOMINEE, MIDLAND, MISSAUKEE, MONTCALM, MONTMORENCY, MUSKEGON, NEWAYGO, OCEANA, OGEMAW, ONTONAGON, OSCEOLA, OSCODA, OTSEGO, OTTAWA, PRESQUE ISLE, ROSCOMMON, SANILAC, SCHOOLCRAFT, SHIAWASSEE, ST. CLAIR, ST. JOSEPH, TUSCOLA, VAN BUREN AND WEXFORD COUNTIES

	Rates	Fringes
CEMENT MASON/CONCRETE FINISHER		
ZONE 1.....	\$ 33.00	18.51
ZONE 2.....	\$ 31.50	18.51

 PLUM0190-003 05/01/2015

ALCONA, ALGER, ALLEGAN, ALPENA, ANTRIM, ARENAC, BARAGA, BARRY, BAY, BENZIE, BERRIEN, BRANCH, CALHOUN, CASS, CHARLEVOIX, CHEBOYGAN, CHIPPEWA, CLARE, CLINTON, CRAWFORD, DELTA, DICKINSON, EATON, EMMET, GENESEE, GLADWIN, GOGEBIC, GRAND TRAVERSE, GRATIOT, HILLSDALE, HOUGHTON, HURON, INGHAM, IONIA, IOSCO, IRON, ISABELLA, JACKSON, KALAMAZOO, KALKASKA, KENT,

KEWEENAW, LAKE, LAPEER, LEELANAU, LENAWEE, LIVINGSTON, LUCE, MACKINAC, MACOMB, MANISTEE, MARQUETTE, MASON, MECOSTA, MENOMINEE, MIDLAND, MISSAUKEE, MONTCALM, MONTMORENCY, MONROE, MUSKEGON, NEWAYGO, OAKLAND, OCEANA, OGEMAW, ONTONAGON, OSCEOLA, OSCODA, OTSEGO, OTTAWA, PRESQUE ISLE, ROSCOMMON, SAGINAW, ST. CLARE, ST. JOSEPH, SANILAC, SCHOOLCRAFT, SHIAWASSEE, TUSCOLA, VAN BUREN, WASHTENAW, WAYNE AND WEXFORD COUNTIES

Rates Fringes

Plumber/Pipefitter - gas distribution pipeline:

Welding in conjunction with gas distribution pipeline work.....	\$ 33.03	20.19
All other work:.....	\$ 24.19	12.28

TEAM0007-004 06/01/2025

AREA 1: ALCONA, ALGER, ALLEGAN, ALPENA, ANTRIM, ARENAC, BARAGA, BARRY, BAY, BENZIE, BERRIEN, BRANCH, CALHOUN, CASS, CHARLEVOIX, CHEBOYGAN, CHIPPEWA, CLARE, CLINTON, CRAWFORD, DELTA, DICKINSON, EATON, EMMET, GLADWIN, GOGEBIC, GRAND TRAVERSE, GRATIOT, HILLSDALE, HOUGHTON, HURON, INGHAM, IONIA, IOSCO, IRON, ISABELLA, JACKSON, KALAMAZOO, KALKASKA, KENT, KEWEENAW, LAKE, LAPEER, LEELANAU, LENAWEE, LUCE, MACKINAC, MANISTEE, MARQUETTE, MASON, MECOSTA, MENOMINEE, MIDLAND, MISSAUKEE, MONTCALM, MONTMORENCY, MUSKEGON, NEWAYGO, OCEANA, OGEMAW, ONTONAGON, OSCEOLA, OSCODA, OTSEGO, OTTAWA, PRESQUE ISLE, ROSCOMMON, SAGINAW, SANILAC, SCHOOLCRAFT, SHIAWASSEE, ST. CLAIR, ST. JOSEPH, TUSCOLA, VAN BUREN AND WEXFORD COUNTIES

AREA 2: GENESEE, LIVINGSTON, MACOMB, MONROE, OAKLAND, WASHTENAW AND WAYNE COUNTIES

Rates Fringes

TRUCK DRIVER

AREA 1		
Euclids, double bottoms and lowboys.....	\$ 33.55	.75 + a+b
Trucks under 8 cu. yds.....	\$ 33.40	.75 + a+b
Trucks, 8 cu. yds. and over.....	\$ 33.40	.75 + a+b
AREA 2		
Euclids, double bottoms and lowboys.....	\$ 33.65	.75 + a+b
Trucks under 8 cu. yds.....	\$ 33.50	.75 + a+b
Trucks, 8 cu. yds. and over.....	\$ 33.50	.75 + a+b

Footnote:

- a. \$470.70 per week
- b. \$68.70 daily

TEAM0247-004 04/01/2013

AREA 1: ALCONA, ALGER, ALLEGAN, ALPENA, ANTRIM, ARENAC, BARAGA, BARRY, BAY, BENZIE, BERRIEN, BRANCH, CALHOUN, CASS, CHARLEVOIX, CHEBOYGAN, CHIPPEWA, CLARE, CLINTON, CRAWFORD, DELTA, DICKINSON, EATON, EMMET, GLADWIN, GOGEBIC, GRAND TRAVERSE, GRATIOT, HILLSDALE, HOUGHTON, HURON, INGHAM, IONIA, IOSCO, IRON, ISABELLA, JACKSON, KALAMAZOO, KALKASKA, KENT, KEWEENAW,

LAKE, LAPEER, LEELANAU, LENAWEE, LUCE, MACKINAC, MANISTEE, MARQUETTE, MASON, MECOSTA, MENOMINEE, MIDLAND, MISSAUKEE, MONTCALM, MONTMORENCY, MUSKEGON, NEWAYGO, OCEANA, OGEMAW, ONTONAGON, OSCEOLA, OSCODA, OTSEGO, OTTAWA, PRESQUE ISLE, ROSCOMMON, SANILAC, SCHOOLCRAFT, SHIAWASSEE, SAGINAW, ST. CLAIR, ST. JOSEPH, TUSCOLA, VAN BUREN AND WEXFORD COUNTIES

AREA 2: GENESEE, LIVINGSTON, MACOMB, MONROE, OAKLAND, WASHTENAW AND WAYNE COUNTIES

	Rates	Fringes
Sign Installer		
AREA 1		
GROUP 1.....	\$ 21.78	11.83
GROUP 2.....	\$ 25.27	11.8375
AREA 2		
GROUP 1.....	\$ 22.03	11.83
GROUP 2.....	\$ 25.02	11.8375

FOOTNOTE:

a. \$132.70 per week, plus \$17.80 per day.

SIGN INSTALLER CLASSIFICATIONS:

GROUP 1: performs all necessary labor and uses all tools required to construct and set concrete forms required in the installation of highway and street signs

GROUP 2: performs all miscellaneous labor, uses all hand and power tools, and operates all other equipment, mobile or otherwise, required for the installation of highway and street signs

 TEAM0247-010 04/01/2018

AREA 1: LAPEER AND SHIAWASSEE COUNTIES

AREA 2: GENESEE, MACOMB, MONROE, OAKLAND, ST. CLAIR, WASHTENAW AND WAYNE COUNTIES

	Rates	Fringes
TRUCK DRIVER (Underground construction)		
AREA 1		
GROUP 1.....	\$ 23.82	19.04
GROUP 2.....	\$ 23.91	19.04
GROUP 3.....	\$ 24.12	19.04
AREA 2		
GROUP 1.....	\$ 24.12	19.04
GROUP 2.....	\$ 24.26	19.04
GROUP 3.....	\$ 24.45	19.04

PAID HOLIDAYS: New Year's Day, Memorial Day, Fourth of July, Labor Day, Thanksgiving Day and Christmas Day.

SCOPE OF WORK: Excavation, site preparation, land balancing, grading, sewers, utilities and improvements; also including but not limited to, tunnels, underground piping, retention,

oxidation, flocculation facilities, conduits, general excavation and steel sheeting for underground construction. Underground construction work shall not include any structural modifications, alterations, additions and repairs to buildings or highway work, including roads, streets, bridge construction and parking lots or steel erection.

TRUCK DRIVER CLASSIFICATIONS

GROUP 1: Truck driver on all trucks (EXCEPT dump trucks of 8 cubic yards capacity or over, pole trailers, semis, low boys, Euclid, double bottom and fuel trucks)

GROUP 2: Truck driver on dump trucks of 8 cubic yards capacity or over, pole trailers, semis and fuel trucks

GROUP 3: Truck driver on low boy, Euclid and double bottom

SUMI2002-001 05/01/2002

	Rates	Fringes
FLAG PERSON.....	\$ 10.10	0.00
LINE PROTECTOR (ZONE 1: GENESEE, MACOMB, MONROE, OAKLAND, WASHTENAW AND WAYNE)....	\$ 26.63	14.45
LINE PROTECTOR (ZONE 2: STATEWIDE (EXCLUDING GENESEE, MACOMB, MONROE, OAKLAND, WASHTENAW AND WAYNE).....	\$ 25.03	14.45
Pavement Marking Machine (ZONE 1: GENESEE, MACOMB, MONROE, OAKLAND, WASHTENAW AND WAYNE COUNTIES) Group 1.....	\$ 35.51	14.45
Pavement Marking Machine (ZONE 1: GENESEE, MACOMB, MONROE, OAKLAND, WASHTENAW AND WAYNE) Group 2.....	\$ 31.96	14.45
Pavement Marking Machine (ZONE 2: STATEWIDE (EXCLUDING GENESEE, MACOMB, MONROE, OAKLAND, WASHTENAW AND WAYNE COUNTIES) Group 1.....	\$ 33.37	14.45
Pavement Marking Machine (ZONE 2: STATEWIDE (EXCLUDING GENESEE, MACOMB, MONROE, OAKLAND, WASHTENAW AND WAYNE) Group 2.....	\$ 30.03	14.45

WORK CLASSIFICATIONS:

PAVEMENT MARKER GROUP 1: Drives or operates a truck mounted striper, grinder, blaster, groover, or thermoplastic melter for the placement or removal of temporary or permanent

pavement markings or markers.

PAVEMENT MARKER GROUP 2: Performs all functions involved for the placement or removal of temporary or permanent pavement markings or markers not covered by the classification of Pavement Marker Group 1 or Line Protector.

LINE PROTECTOR: Performs all operations for the protection or removal of temporary or permanent pavement markings or markers in a moving convoy operation not performed by the classification of Pavement Marker Group 1. A moving convoy operation is comprised of only Pavement Markers Group 1 and Line Protectors.

WELDERS - Receive rate prescribed for craft performing operation to which welding is incidental.

=====
Note: Executive Order (EO) 13706, Establishing Paid Sick Leave for Federal Contractors applies to all contracts subject to the Davis-Bacon Act for which the contract is awarded (and any solicitation was issued) on or after January 1, 2017. If this contract is covered by the EO, the contractor must provide employees with 1 hour of paid sick leave for every 30 hours they work, up to 56 hours of paid sick leave each year. Employees must be permitted to use paid sick leave for their own illness, injury or other health-related needs, including preventive care; to assist a family member (or person who is like family to the employee) who is ill, injured, or has other health-related needs, including preventive care; or for reasons resulting from, or to assist a family member (or person who is like family to the employee) who is a victim of, domestic violence, sexual assault, or stalking. Additional information on contractor requirements and worker protections under the EO is available at <https://www.dol.gov/agencies/whd/government-contracts>.

Note: Executive Order 13658 generally applies to contracts subject to the Davis-Bacon Act that were awarded on or between January 1, 2015 and January 29, 2022, and that have not been renewed or extended on or after January 30, 2022. Executive Order 13658 does not apply to contracts subject only to the Davis-Bacon Related Acts regardless of when they were awarded. If a contract is subject to Executive Order 13658, the contractor must pay all covered workers at least \$13.30 per hour (or the applicable wage rate listed on this wage determination, if it is higher) for all hours spent performing on the contract in 2025. The applicable Executive Order minimum wage rate will be adjusted annually. Additional information on contractor requirements and worker protections under Executive Order 13658 is available at www.dol.gov/whd/govcontracts.

Unlisted classifications needed for work not included within the scope of the classifications listed may be added after award only as provided in the labor standards contract clauses (29CFR 5.5 (a) (1) (iii)).

The body of each wage determination lists the classifications

and wage rates that have been found to be prevailing for the type(s) of construction and geographic area covered by the wage determination. The classifications are listed in alphabetical order under rate identifiers indicating whether the particular rate is a union rate (current union negotiated rate), a survey rate, a weighted union average rate, a state adopted rate, or a supplemental classification rate.

Union Rate Identifiers

A four-letter identifier beginning with characters other than ""SU"", ""UAVG"", ?SA?, or ?SC? denotes that a union rate was prevailing for that classification in the survey. Example: PLUM0198-005 07/01/2024. PLUM is an identifier of the union whose collectively bargained rate prevailed in the survey for this classification, which in this example would be Plumbers. 0198 indicates the local union number or district council number where applicable, i.e., Plumbers Local 0198. The next number, 005 in the example, is an internal number used in processing the wage determination. The date, 07/01/2024 in the example, is the effective date of the most current negotiated rate.

Union prevailing wage rates are updated to reflect all changes over time that are reported to WHD in the rates in the collective bargaining agreement (CBA) governing the classification.

Union Average Rate Identifiers

The UAVG identifier indicates that no single rate prevailed for those classifications, but that 100% of the data reported for the classifications reflected union rates. EXAMPLE: UAVG-OH-0010 01/01/2024. UAVG indicates that the rate is a weighted union average rate. OH indicates the State of Ohio. The next number, 0010 in the example, is an internal number used in producing the wage determination. The date, 01/01/2024 in the example, indicates the date the wage determination was updated to reflect the most current union average rate.

A UAVG rate will be updated once a year, usually in January, to reflect a weighted average of the current rates in the collective bargaining agreements on which the rate is based.

Survey Rate Identifiers

The ""SU"" identifier indicates that either a single non-union rate prevailed (as defined in 29 CFR 1.2) for this classification in the survey or that the rate was derived by computing a weighted average rate based on all the rates reported in the survey for that classification. As a weighted average rate includes all rates reported in the survey, it may include both union and non-union rates. Example: SUFL2022-007 6/27/2024. SU indicates the rate is a single non-union prevailing rate or a weighted average of survey data for that classification. FL indicates the State of Florida. 2022 is the year of the survey on which these classifications and rates are based. The next number, 007 in the example, is an internal number used in producing the wage determination. The date, 6/27/2024 in the example, indicates the survey completion date for the classifications and rates under that identifier.

?SU? wage rates typically remain in effect until a new survey is conducted. However, the Wage and Hour Division (WHD) has the discretion to update such rates under 29 CFR 1.6(c)(1).

State Adopted Rate Identifiers

The ""SA"" identifier indicates that the classifications and prevailing wage rates set by a state (or local) government were adopted under 29 C.F.R 1.3(g)-(h). Example: SAME2023-007 01/03/2024. SA reflects that the rates are state adopted. ME refers to the State of Maine. 2023 is the year during which the state completed the survey on which the listed classifications and rates are based. The next number, 007 in the example, is an internal number used in producing the wage determination. The date, 01/03/2024 in the example, reflects the date on which the classifications and rates under the ?SA? identifier took effect under state law in the state from which the rates were adopted.

WAGE DETERMINATION APPEALS PROCESS

1) Has there been an initial decision in the matter? This can be:

- a) a survey underlying a wage determination
- b) an existing published wage determination
- c) an initial WHD letter setting forth a position on a wage determination matter
- d) an initial conformance (additional classification and rate) determination

On survey related matters, initial contact, including requests for summaries of surveys, should be directed to the WHD Branch of Wage Surveys. Requests can be submitted via email to davisbaconinfo@dol.gov or by mail to:

Branch of Wage Surveys
 Wage and Hour Division
 U.S. Department of Labor
 200 Constitution Avenue, N.W.
 Washington, DC 20210

Regarding any other wage determination matter such as conformance decisions, requests for initial decisions should be directed to the WHD Branch of Construction Wage Determinations. Requests can be submitted via email to BCWD-Office@dol.gov or by mail to:

Branch of Construction Wage Determinations
 Wage and Hour Division
 U.S. Department of Labor
 200 Constitution Avenue, N.W.
 Washington, DC 20210

2) If an initial decision has been issued, then any interested party (those affected by the action) that disagrees with the decision can request review and reconsideration from the Wage and Hour Administrator (See 29 CFR Part 1.8 and 29 CFR Part 7). Requests for review and reconsideration can be submitted via email to dba.reconsideration@dol.gov or by mail to:

Wage and Hour Administrator
 U.S. Department of Labor
 200 Constitution Avenue, N.W.
 Washington, DC 20210

The request should be accompanied by a full statement of the interested party's position and any information (wage payment data, project description, area practice material, etc.) that the requestor considers relevant to the issue.

3) If the decision of the Administrator is not favorable, an interested party may appeal directly to the Administrative Review Board (formerly the Wage Appeals Board). Write to:

Administrative Review Board
U.S. Department of Labor
200 Constitution Avenue, N.W.
Washington, DC 20210.

=====

END OF GENERAL DECISION"

Labor Standards Provisions for Federally Assisted Projects - 29 CFR Part 5

§5.5 Contract provisions and related matters.

(a) The Agency head shall cause or require the contracting officer to insert in full in any contract in excess of \$2,000 which is entered into for the actual construction, alteration and/or repair, including painting and decorating, of a public building or public work, or building or work financed in whole or in part from Federal funds or in accordance with guarantees of a Federal agency or financed from funds obtained by pledge of any contract of a Federal agency to make a loan, grant or annual contribution (except where a different meaning is expressly indicated), and which is subject to the labor standards provisions of any of the acts listed in Sec. 5.1, the following clauses (or any modifications thereof to meet the particular needs of the agency, *Provided*, That such modifications are first approved by the Department of Labor):

(1) *Minimum wages.* (i) All laborers and mechanics employed or working upon the site of the work (or under the United States Housing Act of 1937 or under the Housing Act of 1949 in the construction or development of the project), will be paid unconditionally and not less often than once a week, and without subsequent deduction or rebate on any account (except such payroll deductions as are permitted by regulations issued by the Secretary of Labor under the Copeland Act (29 CFR part 3)), the full amount of wages and bona fide fringe benefits (or cash equivalents thereof) due at time of payment computed at rates not less than those contained in the wage determination of the Secretary of Labor which is attached hereto and made a part hereof, regardless of any contractual relationship which may be alleged to exist between the contractor and such laborers and mechanics. Contributions made or costs reasonably anticipated for bona fide fringe benefits under section 1(b)(2) of the Davis-Bacon Act on behalf of laborers or mechanics are considered wages paid to such laborers or mechanics, subject to the provisions of paragraph (a)(1)(iv) of this section; also, regular contributions made or costs incurred for more than a weekly period (but not less often than quarterly) under plans, funds, or programs which cover the particular weekly period, are deemed to be constructively made or incurred during such weekly period. Such laborers and mechanics shall be paid the appropriate wage rate and fringe benefits on the wage determination for the classification of work actually performed, without regard to skill, except as provided in Sec. 5.5(a)(4). Laborers or mechanics performing work in more than one classification may be compensated at the rate specified for each classification for the time actually worked therein: *Provided*, That the employer's payroll records accurately set forth the time spent in each classification in which work is performed. The wage determination (including any additional classification and wage rates conformed under paragraph (a)(1)(ii) of this section) and the Davis-Bacon poster (WH-1321) shall be posted at all times by the contractor and its subcontractors at the site of the work in a prominent and accessible place where it can be easily seen by the workers.

(ii)(A) The contracting officer shall require that any class of laborers or mechanics, including helpers, which is not listed in the wage determination, and which is to be employed under the contract shall be classified in conformance with the wage determination. The contracting officer shall approve an additional classification and wage rate and fringe benefits therefore only when the following criteria have been met:

(1) The work to be performed by the classification requested is not performed by a classification in the wage determination; and

- (2) The classification is utilized in the area by the construction industry; and
- (3) The proposed wage rate, including any bona fide fringe benefits, bears a reasonable relationship to the wage rates contained in the wage determination.
- (B) If the contractor and the laborers and mechanics to be employed in the classification (if known), or their representatives, and the contracting officer agree on the classification and wage rate (including the amount designated for fringe benefits where appropriate), a report of the action taken shall be sent by the contracting officer to the Administrator of the Wage and Hour Division, Employment Standards Administration, U.S. Department of Labor, Washington, DC 20210. The Administrator, or an authorized representative, will approve, modify, or disapprove every additional classification action within 30 days of receipt and so advise the contracting officer or will notify the contracting officer within the 30-day period that additional time is necessary.
- (C) In the event the contractor, the laborers, or mechanics to be employed in the classification or their representatives, and the contracting officer do not agree on the proposed classification and wage rate (including the amount designated for fringe benefits, where appropriate), the contracting officer shall refer the questions, including the views of all interested parties and the recommendation of the contracting officer, to the Administrator for determination. The Administrator, or an authorized representative, will issue a determination within 30 days of receipt and so advise the contracting officer or will notify the contracting officer within the 30-day period that additional time is necessary.
- (D) The wage rate (including fringe benefits where appropriate) determined pursuant to paragraphs (a)(1)(ii) (B) or (C) of this section, shall be paid to all workers performing work in the classification under this contract from the first day on which work is performed in the classification.
- (iii) Whenever the minimum wage rate prescribed in the contract for a class of laborers or mechanics includes a fringe benefit which is not expressed as an hourly rate, the contractor shall either pay the benefit as stated in the wage determination or shall pay another bona fide fringe benefit or an hourly cash equivalent thereof.
- (iv) If the contractor does not make payments to a trustee or other third person, the contractor may consider as part of the wages of any laborer or mechanic the amount of any costs reasonably anticipated in providing bona fide fringe benefits under a plan or program, Provided, That the Secretary of Labor has found, upon the written request of the contractor, that the applicable standards of the Davis-Bacon Act have been met. The Secretary of Labor may require the contractor to set aside, in a separate account, assets for the meeting of obligations under the plan or program.
- (2) *Withholding.* The **(write in name of Federal Agency or the loan or grant recipient)** shall upon its own action or upon written request of an authorized representative of the Department of Labor withhold or cause to be withheld from the contractor under this contract or any other Federal contract with the same prime contractor, or any other federally-assisted contract subject to Davis-Bacon prevailing wage requirements, which is held by the same prime contractor, so much of the accrued payments or advances as may be considered necessary to pay laborers and mechanics, including apprentices, trainees, and helpers, employed by the contractor or any subcontractor the full amount of wages required by the contract. In the event of failure to pay any laborer or mechanic, including any apprentice, trainee, or helper, employed or working on the site of the

work (or under the United States Housing Act of 1937 or under the Housing Act of 1949 in the construction or development of the project), all or part of the wages required by the contract, the (Agency) may, after written notice to the contractor, sponsor, applicant, or owner, take such action as may be necessary to cause the suspension of any further payment, advance, or guarantee of funds until such violations have ceased.

- (3) *Payrolls and basic records.* (i) Payrolls and basic records relating thereto shall be maintained by the contractor during the course of the work and preserved for a period of three years thereafter for all laborers and mechanics working at the site of the work (or under the United States Housing Act of 1937, or under the Housing Act of 1949, in the construction or development of the project). Such records shall contain the name, address, and social security number of each such worker, his or her correct classification, hourly rates of wages paid (including rates of contributions or costs anticipated for bona fide fringe benefits or cash equivalents thereof of the types described in section 1(b)(2)(B) of the Davis-Bacon Act), daily and weekly number of hours worked, deductions made, and actual wages paid. Whenever the Secretary of Labor has found under 29 CFR 5.5(a)(1)(iv) that the wages of any laborer or mechanic include the amount of any costs reasonably anticipated in providing benefits under a plan or program described in section 1(b)(2)(B) of the Davis-Bacon Act, the contractor shall maintain records which show that the commitment to provide such benefits is enforceable, that the plan or program is financially responsible, and that the plan or program has been communicated in writing to the laborers or mechanics affected, and records which show the costs anticipated or the actual cost incurred in providing such benefits. Contractors employing apprentices or trainees under approved programs shall maintain written evidence of the registration of apprenticeship programs and certification of trainee programs, the registration of the apprentices and trainees, and the ratios and wage rates prescribed in the applicable programs.
- (ii)(A) The contractor shall submit weekly for each week in which any contract work is performed a copy of all payrolls to the (write in name of appropriate federal agency) if the agency is a party to the contract, but if the agency is not such a party, the contractor will submit the payrolls to the applicant, sponsor, or owner, as the case may be, for transmission to the (write in name of agency). The payrolls submitted shall set out accurately and completely all of the information required to be maintained under 29 CFR 5.5(a)(3)(i), except that full social security numbers and home addresses shall not be included on weekly transmittals. Instead, the payrolls shall only need to include an individually identifying number for each employee (e.g., the last four digits of the employee's social security number). The required weekly payroll information may be submitted in any form desired. Optional Form WH-347 is available for this purpose from the Wage and Hour Division Web site at dol.gov/agencies/whd/government-contracts/construction/forms or its successor site. The prime contractor is responsible for the submission of copies of payrolls by all subcontractors. Contractors and subcontractors shall maintain the full social security number and current address of each covered worker, and shall provide them upon request to the (write in name of appropriate federal agency) if the agency is a party to the contract, but if the agency is not such a party, the contractor will submit them to the applicant, sponsor, or owner, as the case may be, for transmission to the (write in name of agency), the contractor, or the Wage and Hour Division of the Department of Labor for purposes of an investigation or audit of compliance with prevailing wage requirements. It is not a violation of this section for a prime contractor to require a subcontractor to provide addresses and social security numbers to the prime contractor for its own records, without weekly submission to the sponsoring government agency (or the applicant, sponsor, or owner).

- (B) Each payroll submitted shall be accompanied by a "Statement of Compliance", signed by the contractor or subcontractor or his or her agent who pays or supervises the payment of the persons employed under the contract and shall certify the following:
- (1) That the payroll for the payroll period contains the information required to be provided under Sec. 5.5 (a)(3)(ii) of Regulations, 29 CFR part 5, the appropriate information is being maintained under Sec. 5.5 (a)(3)(i) of Regulations, 29 CFR part 5, and that such information is correct and complete.
 - (2) That each laborer or mechanic (including each helper, apprentice, and trainee) employed on the contract during the payroll period has been paid the full weekly wages earned, without rebate, either directly or indirectly, and that no deductions have been made either directly or indirectly from the full wages earned, other than permissible deductions as set forth in Regulations, 29 CFR part 3;
 - (3) That each laborer or mechanic has been paid not less than the applicable wage rates and fringe benefits or cash equivalents for the classification of work performed, as specified in the applicable wage determination incorporated into the contract.
- (C) The weekly submission of a properly executed certification set forth on the reverse side of Optional Form WH-347 shall satisfy the requirement for submission of the "Statement of Compliance" required by paragraph (a)(3)(ii)(B) of this section.
- (D) The falsification of any of the above certifications may subject the contractor or subcontractor to civil or criminal prosecution under section 1001 of title 18 and section 231 of title 31 of the United States Code.
- (iii) The contractor or subcontractor shall make the records required under paragraph (a)(3)(i) of this section available for inspection, copying, or transcription by authorized representatives of the Michigan Department of Environment, Great Lakes, and Energy or the Department of Labor, and shall permit such representatives to interview employees during working hours on the job. If the contractor or subcontractor fails to submit the required records or to make them available, the Federal agency may, after written notice to the contractor, sponsor, applicant, or owner, take such action as maybe necessary to cause the suspension of any further payment, advance, or guarantee of funds. Furthermore, failure to submit the required records upon request or to make such records available may be grounds for debarment action pursuant to 29 CFR 5.12.
- (4) *Apprentices and trainees-* (i) Apprentices. Apprentices will be permitted to work at less than the predetermined rate for the work they performed when they are employed pursuant to and individually registered in a bona fide apprenticeship program registered with the U.S. Department of Labor, Employment and Training Administration, Office of Apprenticeship Training, Employer and Labor Services, or with a State Apprenticeship Agency recognized by the Office, or if a person is employed in his or her first 90 days of probationary employment as an apprentice in such an apprenticeship program, who is not individually registered in the program, but who has been certified by the Office of Apprenticeship Training, Employer and Labor Services or a State Apprenticeship Agency (where appropriate) to be eligible for probationary employment as an apprentice. The allowable ratio of apprentices to journeymen on the job site in any craft classification shall not be greater than the ratio permitted to the contractor as to the entire work force under the registered program. Any worker listed on a payroll at an apprentice wage rate, who is not registered or otherwise employed as stated above, shall be paid not less than the

applicable wage rate on the wage determination for the classification of work actually performed. In addition, any apprentice performing work on the jobsite in excess of the ratio permitted under the registered program shall be paid not less than the applicable wage rate on the wage determination for the work actually performed. Where a contractor is performing construction on a project in a locality other than that in which its program is registered, the ratios and wage rates (expressed in percentages of the journeyman's hourly rate) specified in the contractor's or subcontractor's registered program shall be observed. Every apprentice must be paid at not less than the rate specified in the registered program for the apprentice's level of progress, expressed as a percentage of the journeymen hourly rate specified in the applicable wage determination. Apprentices shall be paid fringe benefits in accordance with the provisions of the apprenticeship program. If the apprenticeship program does not specify fringe benefits, apprentices must be paid the full amount of fringe benefits listed on the wage determination for the applicable classification. If the Administrator determines that a different practice prevails for the applicable apprentice classification, fringes shall be paid in accordance with that determination. In the event the Office of Apprenticeship Training, Employer and Labor Services, or a State Apprenticeship Agency recognized by the Office, withdraws approval of an apprenticeship program, the contractor will no longer be permitted to utilize apprentices at less than the applicable predetermined rate for the work performed until an acceptable program is approved.

- (ii) Trainees. Except as provided in 29 CFR 5.16, trainees will not be permitted to work at less than the predetermined rate for the work performed unless they are employed pursuant to and individually registered in a program which has received prior approval, evidenced by formal certification by the U.S. Department of Labor, Employment and Training Administration. The ratio of trainees to journeymen on the job site shall not be greater than permitted under the plan approved by the Employment and Training Administration. Every trainee must be paid at not less than the rate specified in the approved program for the trainee's level of progress, expressed as a percentage of the journeyman hourly rate specified in the applicable wage determination. Trainees shall be paid fringe benefits in accordance with the provisions of the trainee program. If the trainee program does not mention fringe benefits, trainees shall be paid the full amount of fringe benefits listed on the wage determination unless the Administrator of the Wage and Hour Division determines that there is an apprenticeship program associated with the corresponding journeyman wage rate on the wage determination which provides for less than full fringe benefits for apprentices. Any employee listed on the payroll at a trainee rate who is not registered and participating in a training plan approved by the Employment and Training Administration shall be paid not less than the applicable wage rate on the wage determination for the classification of work actually performed. In addition, any trainee performing work on the job site in excess of the ratio permitted under the registered program shall be paid not less than the applicable wage rate on the wage determination for the work actually performed. In the event the Employment and Training Administration withdraws approval of a training program, the contractor will no longer be permitted to utilize trainees at less than the applicable predetermined rate for the work performed until an acceptable program is approved.
- (iii) Equal employment opportunity. The utilization of apprentices, trainees and journeymen under this part shall be in conformity with the equal employment opportunity requirements of Executive Order 11246, as amended, and 29 CFR part 30.
- (5) *Compliance with Copeland Act requirements.* The contractor shall comply with the requirements of 29 CFR part 3, which are incorporated by reference in this contract.

- (6) *Subcontracts.* The contractor or subcontractor shall insert in any subcontracts the clauses contained in 29 CFR 5.5(a)(1) through (10) and such other clauses as the (write in the name of the Federal agency) may by appropriate instructions require, and also a clause requiring the subcontractors to include these clauses in any lower tier subcontracts. The prime contractor shall be responsible for the compliance by any subcontractor or lower tier subcontractor with all the contract clauses in 29 CFR 5.5.
- (7) *Contract termination: debarment.* A breach of the contract clauses in 29 CFR 5.5 may be grounds for termination of the contract, and for debarment as a contractor and a subcontractor as provided in 29 CFR 5.12.
- (8) *Compliance with Davis-Bacon and Related Act requirements.* All rulings and interpretations of the Davis-Bacon and Related Acts contained in 29 CFR parts 1, 3, and 5 are herein incorporated by reference in this contract.
- (9) *Disputes concerning labor standards.* Disputes arising out of the labor standards provisions of this contract shall not be subject to the general disputes clause of this contract. Such disputes shall be resolved in accordance with the procedures of the Department of Labor set forth in 29CFR parts 5, 6, and 7. Disputes within the meaning of this clause include disputes between the contractor (or any of its subcontractors) and the contracting agency, the U.S. Department of Labor, or the employees or their representatives.
- (10) *Certification of eligibility.* (i) By entering into this contract, the contractor certifies that neither it (nor he or she) nor any person or firm who has an interest in the contractor's firm is a person or firm ineligible to be awarded Government contracts by virtue of section 3(a) of the Davis-Bacon Act or 29 CFR 5.12(a)(1).
- (ii) No part of this contract shall be subcontracted to any person or firm ineligible for award of a Government contract by virtue of section 3(a) of the Davis-Bacon Act or 29 CFR 5.12(a)(1).
- (iii) The penalty for making false statements is prescribed in the U.S. Criminal Code, 18 U.S.C.1001.
- (b) *Contract Work Hours and Safety Standards Act.* The Agency Head shall cause or require the contracting officer to insert the following clauses set forth in paragraphs (b)(1), (2), (3), and (4) of this section in full in any contract in an amount in excess of \$100,000 and subject to the overtime provisions of the Contract Work Hours and Safety Standards Act. These clauses shall be inserted in addition to the clauses required by Sec. 5.5(a) or 4.6 of part 4 of this title. As used in this paragraph, the terms laborers and mechanics include watchmen and guards.
- (1) *Overtime requirements.* No contractor or subcontractor contracting for any part of the contract work which may require or involve the employment of laborers or mechanics shall require or permit any such laborer or mechanic in any workweek in which he or she is employed on such work to work in excess of forty hours in such workweek unless such laborer or mechanic receives compensation at a rate not less than one and one-half times the basic rate of pay for all hours worked in excess of forty hours in such workweek.
- (2) *Violation; liability for unpaid wages; liquidated damages.* In the event of any violation of the clause set forth in paragraph (b)(1) of this section the contractor and any subcontractor responsible there for shall be liable for the unpaid wages. In addition, such contractor and subcontractor shall be

liable to the United States (in the case of work done under contract for the District of Columbia or a territory, to such District or to such territory), for liquidated damages. Such liquidated damages shall be computed with respect to each individual laborer or mechanic, including watchmen and guards, employed in violation of the clause set forth in paragraph (b)(1) of this section, in the sum of \$10 for each calendar day on which such individual was required or permitted to work in excess of the standard workweek of forty hours without payment of the overtime wages required by the clause set forth in paragraph (b)(1) of this section.

- (3) Withholding for unpaid wages and liquidated damages. The ***(write in the name of the Federal agency or the loan or grant recipient)*** shall upon its own action or upon written request of an authorized representative of the Department of Labor withhold or cause to be withheld, from any moneys payable on account of work performed by the contractor or subcontractor under any such contract or any other Federal contract with the same prime contractor, or any other federally-assisted contract subject to the Contract Work Hours and Safety Standards Act, which is held by the same prime contractor, such sums as may be determined to be necessary to satisfy any liabilities of such contractor or subcontractor for unpaid wages and liquidated damages as provided in the clause set forth in paragraph (b)(2) of this section.
- (4) Subcontracts. The contractor or subcontractor shall insert in any subcontracts the clauses set forth in paragraph (b)(1) through (4) of this section and also a clause requiring the subcontractors to include these clauses in any lower tier subcontracts. The prime contractor shall be responsible for compliance by any subcontractor or lower tier subcontractor with the clauses set forth in paragraphs (b)(1) through (4) of this section.
- (c) In addition to the clauses contained in paragraph (b), in any contract subject only to the Contract Work Hours and Safety Standards Act and not to any of the other statutes cited in Sec.5.1, the Agency Head shall cause or require the contracting officer to insert a clause requiring that the contractor or subcontractor shall maintain payrolls and basic payroll records during the course of the work and shall preserve them for a period of three years from the completion of the contract for all laborers and mechanics, including guards and watchmen, working on the contract. Such records shall contain the name and address of each such employee, social security number, correct classifications, hourly rates of wages paid, daily and weekly number of hours worked, deductions made, and actual wages paid. Further, the Agency Head shall cause or require the contracting officer to insert in any such contract a clause providing that the records to be maintained under this paragraph shall be made available by the contractor or subcontractor for inspection, copying, or transcription by authorized representatives of the Michigan Department of Environment, Great Lakes, and Energy and the Department of Labor, and the contractor or subcontractor will permit such representatives to interview employees during working hours on the job.

Disadvantaged Business Enterprises (DBE) Requirements

Prime contractors bidding on this project must follow, document, and maintain documentation of their Good Faith Efforts (GFE), as listed below, to ensure that Disadvantaged Business Enterprises (DBEs) have the opportunity to participate in the project by increasing DBE awareness of procurement efforts and outreach. Bidders must make the following Good Faith Efforts for any work that will be subcontracted.

1. Ensure DBEs are made aware of contracting opportunities to the fullest extent practicable through outreach and recruitment activities. Place DBEs on solicitation lists and solicit DBEs whenever they are potential sources.
2. Make information on forthcoming opportunities available to DBEs. Arrange timeframes for contracts and establish delivery schedules, where the requirements permit, in a way that encourages and facilitates participation by DBEs in the competitive process. Whenever possible, post solicitation for bids or proposals for a minimum of 30 calendar days before the bid or proposal closing date. The DBEs should be given a minimum of 5 days to respond to the posting.
3. Consider in the contracting process whether firms competing for large contracts can be subcontracted with DBEs. Divide total requirements, when economically feasible, into smaller tasks or quantities to permit maximum participation by DBEs in the competitive process.
4. Encourage contracting with a consortium of DBEs when a contract is too large for one DBE firm to handle individually.
5. Use the services and assistance of the Small Business Administration and the Minority Business Development Agency of the U.S. Department of Commerce.

Subsequent to compliance with the Good Faith Efforts, the following conditions also apply under the DBE requirements. Completed Good Faith Efforts Worksheets, along with the required supporting documentation outlined in the instructions, must be submitted with your bid proposal. EPA form 6100-2 must also be provided at the pre-bid meeting. A copy of this form is available on the Forms and Guidance page of the EGLE Water Infrastructure Financing Section website.

1. The prime contractor must pay its subcontractor for work that has been satisfactorily completed no more than 30 days from the prime contractor's receipt of payment from the owner.
2. The prime contractor must notify the owner in writing prior to the termination of any DBE subcontractor for convenience by the prime contractor and employ the Good Faith Efforts if soliciting a replacement contractor.
3. If a DBE contractor fails to complete work under the subcontract for any reason, the prime contractor must employ the Good Faith Efforts if soliciting a replacement contractor.
4. The prime contractor must employ the Good Faith Efforts.

MICHIGAN DEPARTMENT OF ENVIRONMENT, GREAT LAKES, AND ENERGY

Good Faith Efforts Worksheet

Bidder: _____

Subcontract Area of Work (one per worksheet): _____

Outreach Goal: Solicit a minimum of three (3) DBEs via email/letter/fax. It is recommended that various sources be used to locate the minimum number of DBEs. The Michigan Department of Transportation (MDOT) website and www.sam.gov registries may be two resources used to find a minimum of three DBEs.

List the DBEs contacted for the above area of work and complete the following information for each.

Company Name	Contact Method	Date Contacted	Price Quote Received	Accepted or Rejected	If rejected, explain why

Explanation for Not Achieving a Minimum of Three Contacts; you may include a printout of the MDOT and www.sam.gov search results (attach extra sheets if necessary):

MITA DBE Posting Date (if applicable): _____
 (Attach a copy of the DBE advertisement)

Other Efforts (attach extra sheets if necessary):

Please include the completed worksheet and supporting documentation with the bid proposal.

Instructions to Bidders for the Completion of the Good Faith Efforts Worksheet

1. Separate worksheets must be provided for each area of work to be subcontracted out. This includes both major and minor subcontracts.
2. A minimum of three (3) DBEs must be contacted by a verifiable means of communication such as email, letter, or fax for each area of work to be subcontracted out. Copies of the solicitation letters/emails and fax confirmation sheets must be provided with the worksheet.
3. If less than three (3) DBEs exist statewide for the area of work, then provide documentation that other DBE resources were consulted. This may include the MDOT and www.sam.gov registries and an advertisement in a publication. A printout of the website searched (conducted prior to the end of the bid period) must be submitted.
4. Posting solicitations for quotes/proposals from DBEs on the MITA website (www.mitadbe.com) is highly recommended to facilitate participation in the competitive process whenever possible. The solicitation needs to identify the project and the areas of work to be subcontracted out. A copy of the MITA DBE advertisement must be submitted with the Good Faith Efforts worksheet, if used, or a printout of the resulting quotes posted to the MITA website can be submitted with this form as supporting documentation.
5. If the area of work is so specialized that no DBEs exist, then an explanation is required to support that conclusion, including the documentation required in number 3 above.
6. The date of the DBE contact must be identified, as it is important to document that the DBE solicitation was made during the bid period and that sufficient time was given for the DBE to return a quote.
7. Each DBE firm's price quote must be identified if one was received, or N/A entered on the worksheet if a quote was not received. Copies of all quotes must be submitted with the worksheet.
8. If a quote was received, indicate if it was accepted or rejected. Justification for not accepting a quote and not using the DBE subcontractor must be provided.
9. Under Other Efforts, please indicate additional steps you have taken to obtain DBE contractors and provide the appropriate supporting documentation such as:
 - Follow-up emails, faxes, or letters.
 - Copies of announcements/postings in newspapers, trade publications, or minority media that target DBE firms.

Disadvantaged Business Enterprise (DBE) and Good Faith Efforts (GFE) Requirements Frequently Asked Questions Regarding Contractor Compliance

Q: What is the Good Faith Efforts Worksheet and how is it completed?

A: The worksheet captures efforts by the prime contractor to solicit DBEs for each area of work type that will be subcontracted out. A separate GFE Worksheet must be provided by the prime contractor for each area of work type to be subcontracted out. There are specific instructions that accompany the worksheet that prescribe minimum efforts which bidders must make in order to be in compliance with the DBE requirements.

Q: Can non-certified DBEs be used?

A: While non-certified DBEs can be used, only DBEs, MBEs, and WBEs that are certified by EPA, SBA, or MDOT (or by tribal, state and local governments, as long as their standards for certification meet or exceed the standards in EPA policy) can be counted toward the fair share goal. Proof of certification by one of these recognized and approved agencies should be sought from each DBE.

Q: How does a DBE get certified?

A: Applications to be certified by MDOT can be found at

mdotjboss.state.mi.us/MUCPWeb/eligibilityRequirements.htm

To register with the U.S. Small Business Association visit sba.gov/federal-contracting/contracting-assistance-programs/small-disadvantaged-business

To be certified by EPA, a DBE must first have sought certification through SBA, MDOT, or a tribal, state, or local organization and be unsuccessful in that attempt.

Q: If a bidder follows the MDOT DBE requirements, will the bidder comply with the SRF DBE requirements?

A: No. Federally funded highway projects utilize DBE goals, which require a certain percentage of work be performed by DBE subcontractors. For SRF projects, there is no financial goal. However, there is a solicitation effort goal. Bidders must use Good Faith Efforts for each and every area of work to be subcontracted out to obtain DBEs. The bidders are not required to use DBEs if the quotes are higher than non-DBE subcontractors. There is no required DBE participation percentage contract goal for the SRF. However, if the SRF project is part of a joint project with MDOT, the project can be excluded from SRF DBE requirements (i.e., the Good Faith Efforts Worksheet is not required) as it would be difficult to comply with both programs' requirements.

Q: Should the Good Faith Efforts Worksheet and supporting documentation be submitted with bid proposals?

A: Yes. This is a requirement to document that the contractor has complied with the DBE requirements and GFE. These compliance efforts must be done during the bidding phase and not after-the-fact. It is highly recommended that the need for these efforts and the submittal of the forms with the bid proposals be emphasized at the pre-bid meeting. Failure to show that the Good Faith Efforts were complied with during the bidding process can lead to a prime contractor being found non-responsive.

Q: What kinds of documentation should a contractor provide to document solicitation efforts?

A: Documentation can include fax confirmation sheets, copies of solicitation letters/emails, printouts of online solicitations, printouts of online search results, affidavits of publication in newspapers, etc.

- Q:** What if no forms are turned in with the bid proposal or forms are blank or incomplete? Should this be cause to determine that the bidder is non-responsive?
- A:** While the Good Faith Efforts Worksheet is important, it is more critical to confirm that the contractor complied with the DBE requirements prior to bid opening. The owner should contact the bidder as soon as deficiencies are noted for documentation of efforts taken to comply with the DBE requirements. Immediate submittal of the completed forms will be acceptable provided the Good Faith Efforts were made and it is just a matter of transferring information to the forms.
- Q:** How much time will compliance with GFE require in terms of structuring an adequate bidding period?
- A:** Due to the extent of the efforts required, a minimum of 30 calendar days is recommended between bid posting and bid opening to ensure adequate time for contractors to locate certified DBEs and solicit quotes.
- Q:** How does a contractor locate certified DBEs?
- A:** MDOT has a directory of all Michigan certified entities located at mdotjboss.state.mi.us/MUCPWeb/. Additionally, the federal System for Award Management (SAM) is another place to search and can be found at sam.gov. SAM contains information from the former Central Contractor Registration (CCR) database.
- Q:** If the bidder does not intend to subcontract any work, what forms, if any, must be provided with the bid proposal?
- A:** The bidder should complete the Good Faith Efforts Worksheet with a notation that no subcontracting will be done. However, if the bidder is awarded the contract and then decides to subcontract work at any point, then the Good Faith Efforts must be made to solicit DBEs.
- Q:** If the prime contractor is a DBE, does he have to solicit DBE subcontractors?
- A:** Yes, the DBE requirements still apply if the prime intends to subcontract work out. GFE must be used to solicit DBEs.
- Q:** If the area of work is one where there are less than three DBE contractors, how is the contractor to document this?
- A:** Copies of printouts from MDOT and SAM showing no DBEs and advertisements soliciting quotes for all subcontract areas, including the questionable areas, will be adequate if the dates on the printouts are prior to the bid or proposal closing date.

MICHIGAN DEPARTMENT OF ENVIRONMENT, GREAT LAKES, AND ENERGY

Certification Regarding Debarment, Suspension, and Other Responsibility Matters

The prime contractor must provide a completed *Certification Regarding Debarment, Suspension, and Other Responsibility Matters Form* with its bid or proposal package to the owner.

The prospective participant certifies, to the best of its knowledge and belief, that it and its principals:

- (1) Are not presently debarred, suspended, proposed for debarment, declared ineligible, or voluntarily excluded from participation in transactions under federal nonprocurement programs by any federal department or agency;
- (2) Have not, within the three-year period preceding the proposal, had one or more public transactions (federal, state, or local) terminated for cause or default; and
- (3) Are not presently indicted or otherwise criminally or civilly charged by a government entity (federal, state, or local) and have not, within the three-year period preceding the proposal, been convicted of or had a civil judgment rendered against it:
 - (a) For the commission of fraud or a criminal offense in connection with obtaining, attempting to obtain, or performing a public transaction (federal, state, or local) or a procurement contract under such a public transaction;
 - (b) For the violation of federal or state antitrust statutes, including those proscribing price fixing between competitors, the allocation of customers between competitors, or bid rigging; or
 - (c) For the commission of embezzlement, theft, forgery, bribery, falsification, or destruction of records, making false statements, or receiving stolen property.

I understand that a false statement on this certification may be grounds for the rejection of this proposal or the termination of the award. In addition, under 18 U.S.C. §1001, a false statement may result in a fine of up to \$10,000 or imprisonment for up to five years, or both.

Name and Title of Authorized Representative

Name of Participant Agency or Firm

Signature of Authorized Representative

Date

I am unable to certify to the above statement. Attached is my explanation.



SPECIFICATIONS & PLANS
(includes PROJECT ADDRESS LIST
and STANDARD SPECIFICATIONS)

**DWSRF Non-Copper Service Line
Replacement FY 26**

Bid Reference #: 91244-051.0

April 2026

City of Kalamazoo FY 26 DWSRF LSLR Project Specifications

GENERAL

The intent of this project is to replace all water services that are not copper to copper.

Owner = City of Kalamazoo

Engineer = Anna Crandall, PE

All plumbing materials for water service replacements will be provided by contractor. Contractor to provide gravel, HMA, sidewalk, topsoil, seed, etc.

1. SPECIFICATIONS

The work under this contract shall be performed in accordance with these Project Specifications and the City of Kalamazoo Standard Specifications for Water Main and Service Installation dated 6/14/2021.

In the event of a conflict between the Standard Specifications and these Project Specifications, the Project Specifications shall prevail.

The Michigan Department of Transportation Standard Specifications for Highway Construction 2020 Edition are included by specific paragraph reference.

2. PROJECT AREA

The Contractor shall confine his work to the project area needed for the work. Project area address list and overview map are provided in these specifications. Additional information of service line material by address will be provided to the Contractor upon contract award. Any other area required for equipment, material storage or for construction operation shall be the Contractor's responsibility. The Contractor shall receive written permission from the Owners of adjacent properties before using any portion of the property outside the project area.

The Contractor shall take all necessary precautions to minimize disturbances to the area during the construction period. All damage caused by the Contractor or sub-contractors to the property outside the project area shall be repaired at no expense either to the property owner or to this project.

3. SUMMARY OF WORK

Work to be constructed in this project generally includes furnishing and installing the following:

Existing Water Service Investigation: "Potholing"
Approximately 500 Water Service Lead Replacements
Approximately 100 Abandon Blinds

All labor, materials, equipment, transportation, and activity or costs necessary for completion of this work shall be included in this contract unless specifically stated otherwise. There may be a few addresses included in these plans and specifications where the non-copper service line has already been replaced by the City of Kalamazoo as an emergency replacement due to high sample results. Under the Michigan Lead Copper Rule, partial lead service line replacements are not allowed. Once the service line is taken out of service for replacement, all non-copper or non-plastic portions of that service line shall be replaced prior to service being reconnected and the water turned back on to reduce particulate lead release.

4. PERMITS

Contractor shall obtain Right-of Way permits and coordinate with City of Kalamazoo Right-of-Way Coordinators throughout the project as moving from street to street.

5. SCHEDULING

The Contractor shall file a construction schedule with the Engineer and Owner and receive approval in writing prior to commencing construction.

The Contractor and the Construction Observer shall coordinate/communicate schedule of shut down and reconnection of service with Resident/Bill Payer for each property.

The Construction Observer shall distribute water filters and instructions once new connection is completed.

Certain areas within the project may require street closing. The Contractor shall coordinate his work with the Owner and shall take the necessary precautions required by the Owner to minimize traffic interference.

Deadline for Lead Service Replacement Services:
June 30, 2028;

All costs associated with scheduling shall be considered incidental to the project.

6. MAINTENANCE OF TRAFFIC

Local traffic shall be maintained at all times during construction. All traffic control devices and placement shall be in accordance with the current MDOT Standards and Specifications for Construction or as directed by engineer.

During the progress of work, the Contractor shall accommodate vehicular traffic in road rights-of-way as provided in these specifications. Access to fire hydrants, water and gas valves shall be maintained at all times during construction.

Where streets and driveways are obstructed, the contractor shall place and maintain temporary driveways, ramps, etc., which, in the opinion of the Engineer, are necessary to accommodate the public. The Contractor shall provide access at night and on weekends for all properties in the immediate construction area. Emergency vehicle access shall be maintained at all times.

The Contractor shall be required to keep the surface of the roadway in a smooth, dust free and accessible condition for adjoining properties at all times. Dust control shall also apply to paved roads in the project area and are to be kept clean by the use of a mechanical sweeping device. Maintenance shall consist of grading the disturbed or graveled surface and maintaining the surface free of “wash- boards” and “chuck-holes”, suitable for traffic.

The Contractor shall inform the schools, local police, ambulance services and fire department in advance of his program of street obstruction and detours. Detouring and construction signing shall be in accordance with Michigan Manual of Uniform Traffic Control at the direction of the Owner.

Prior to construction the Contractor shall submit and obtain Owner approval for his traffic control plans, including detour plans and schedules. Full closure requires 2 weeks' notice to Public Works for media release.

The Owner must approve all detours. The Contractor shall pay for all costs of detours. All costs shall be included under proposal item “Traffic Control”.

Cost of maintaining traffic including detouring, construction signing, and traffic control shall be paid as specified in the proposal form.

7. LIMITATION ON OPERATIONS

The Contractor shall at all times conduct his work so that there is a minimum of inconvenience to the residents, businesses and industries within the project area. Work on City of Kalamazoo Major Streets shall be limited to April through November. Work on City of Kalamazoo Local Streets for this project can occur any time of year, weather dependent. Patches shall be restored with concrete per Exhibit B and milled and paved with HMA when seasonal restrictions are lifted – this is only

acceptable on Local Streets. All Major Streets shall be paved back with HMA. Sections will need to be milled and paved based on patch density and existing pavement condition per the attached Standard Streets Details.

8. PROTECTION OF WORK

The Contractor shall protect the work until it is accepted by the Engineer. Any part of the completed work that is damaged prior to acceptance by Engineer shall be replaced at the Contractor's expense.

9. DUST CONTROL

All haul roads, detour roads and other public and private roads (including backfilled trenches), driveways and parking lots used by the Contractor must be maintained in a dust free condition during the life of this Contract. The control of dust shall be accomplished by sweeping and by the application of dust control materials. The materials and methods of application shall be approved by the Engineer and shall be applied as often as is necessary to control the dust, or if directed to do so by the Owner's representative. If directed to do so, the Contractor shall complete the dust control measures within 24 hours. All spillage on public roadways used as haul routes shall be cleaned daily.

Costs of providing dust control shall be included in the major items of construction. Therefore, no additional payment shall be made.

10. MATERIAL HAUL ROADS

Any spillage on public roadways used as haul routes shall be cleaned daily.

Use of gravel roads is prohibited. Permission to use gravel roads shall be given to Contractor only if Contractor assumes responsibility of maintenance, dust control and restoration of the gravel roads to the satisfaction of the Owner.

11. DIGITAL PHOTOGRAPHS

The Contractor shall digitally photograph entire project area prior to construction. These photographs shall be made available to the Contractor, Engineer and Owner during construction of the project. Payment shall be included in the major items of work.

12. TOPSOIL STRIPPING

The Contractor shall perform clearing, grubbing, and stripping of topsoil. Stripped topsoil shall be stockpiled on the site. The Contractor shall be allowed to use this stockpiled material when placing topsoil on the site and shall provide additional topsoil

as necessary to meet the thickness specified. No fill shall be placed over topsoil or organic material. At completion of construction, topsoil shall be spread uniformly over the disturbed areas. Any excess topsoil shall become the property of the Contractor and properly disposed of offsite.

13. PROTECTION OF NATURAL RESOURCES

The Contractor shall take all necessary steps to prevent damage to fish and game habitats and to preserve the natural resources of the State. Excavation and backfill shall be carried out so as to minimize discharge of damaging material into any stream, lake, or reservoir.

The Contractor shall exercise caution in the discharge of waters from pumps, deep wells, or well point systems in order that such discharges do not cause erosion, siltation, soil depositions, etc., in sewers, streams or other water courses or drainage structures.

The Contractor shall not permit any sand or debris of any kind to enter the existing ditches, streams, storm sewers or culverts.

The rules and regulations of all work shall comply with Part 301 (Inland Lakes and Streams Act), Part 91 (Soil Erosion and Sedimentation Control Act), and Part 303 (Wetlands Protection Act) of Michigan Public Act 451, 1994.

14. SOIL EROSION AND SEDIMENTATION CONTROL(Part 91, P.A. No. 451)

All work shall comply with the rules and regulations of the Michigan Soil Erosion and Sedimentation Control Act (Part 91, Michigan Public Act No. 451, 1994).

These measures have been developed from the Michigan Unified Keying System, described in "Michigan Soil Erosion and Sedimentation Control Guide Book" published by the Land and Water Management Division of MDEQ.

All of these measures shall be in place prior to excavating where required and shall be maintained until construction is complete except 6, "seeding with mulch matting" or aggregate cover, which shall be done immediately after the pipe installation.

Net erosion blankets containing plastic or synthetic net or netting shall no longer be authorized, purchased, nor approved for use. Only Erosion Control Blankets such as North American Green Bionet S150BN, and Western Wood fibers EXCEL SS-2 All Natural (biodegradable jute/scrim netting with leno weave type mesh), or equivalent, are considered acceptable products.

The cost of the above requirements shall be included in the price of the major items of work.

15. DEWATERING

When dewatering of groundwater is required, the Contractor shall limit the dewatering operation to the minimum time and depth required for construction. The Contractor shall submit to the Owner a dewatering plan indicating how dewatering will be accomplished, along with how and where dewatering discharge will be directed and controlled. Dewatering flows shall not be directed immediately to any watercourse. All flow shall be directed to an “ecolobag” or Engineer approved equal sediment trap. The sediment trap shall be located to allow a minimum overland flow 100 feet prior to entering any water course.

Dewatering shall be included in the price of the major items of work.

16. EXCESS DIRT

The Contractor shall remove all excess material resulting from construction and arrange for disposal at a suitable site. Excess material shall be the property of the Contractor and shall be disposed of properly by the Contractor.

17. USE OF SLAG

No slag shall be permitted.

18. EXISTING UTILITIES

As an aid to the Contractor, various utilities and underground structures are shown on the plans. All information concerning shown utilities were taken from field topo and from available records, but the Owner and the Engineer do not guarantee that the location shown on the plans is accurate, nor that additional underground utilities or structures may not be encountered.

The Contractor shall notify Miss Dig and Utility Companies for utility locations before starting any open cut or tunnel construction or before drilling holes for construction purposes. He shall cooperate with the utility companies in any repair, relocation, or other work to be performed on the utility caused by the construction of the contract.

The Contractor shall be fully responsible for the location, protection, relocation, replacement, etc. for all existing underground utilities which may reasonably be expected in any area, regardless of whether or not such utilities are shown on the plans. Items in this category shall include, but not necessarily be limited to; water mains and services, gas mains and services, storm sewer and catch basin leads, telephone, electric, and cable TV wire, etc. Such work shall be considered incidental to the major items of construction unless otherwise noted on the construction drawings.

A. Contractor shall coordinate with the Owner to locate all private utilities.

- B. Sewers (Storm, Culverts, and Under drains)
City of Kalamazoo provides storm sewer service in the project area.
- C. Sanitary Sewer
City of Kalamazoo provides sanitary sewer service in the project area.
- D. Water Main
City of Kalamazoo provides water service in the project area.
- E. Cable
Charter Communications provides cable service in the project area.
- F. Electric Services
Consumers Energy operates the electrical system in the project area.
- G. Gas
Consumers Energy provides natural gas service in the project area.
- H. Telephone
AT&T Michigan provides telephone service in the project area.
- I. Miss Dig
The Contractor shall contact "MISS DIG" not less than 72 hours before starting construction for assistance in locating utilities or for any work to be done on utilities. The toll free phone number is (800) 482-7171.

19. PROTECTION OF UTILITIES

The Contractor shall furnish, install, use, and maintain adequate sheeting, shoring, bracing, and stabilization methods required to ensure the integrity of existing underground utilities both during and after completion of construction. When necessary, the Contractor shall shore and brace existing utility poles which interfere with construction.

The Contractor shall be responsible for repairing all cracks, leaks, breaks, and defects in the utilities during the standard contract guarantee period of two year after acceptance of construction, at no additional cost either to the project owner or the owner of the utility.

Should service provided by public utilities be interrupted by the Contractor, the Contractor shall be responsible for returning all public utilities to normal working order.

Locations of existing utilities are shown using available records. The Owner and the Engineer do not guarantee that the locations shown on the plans are accurate. Additional underground utilities or structures may be encountered. No additional

payment will be made due to unknown or inaccurately located utilities. The Contractor shall notify Miss Dig and Utility Companies for utility locations before starting any earth moving operations.

The Contractor shall coordinate daily construction activities with that of utility companies which may be relocating some of their facilities as required by the project. No claim for additional compensation will be allowed based on delays caused by utility relocations.

Cost for complying with this specification shall be included in major items of work in the proposal. Therefore, no additional payment for these items shall be made.

20. UTILITY POLES

When necessary, the Contractor shall shore and brace utility poles that interfere with construction. Shoring and bracing shall be such that sinking or excessive tilting does not take place. All relocation or removing and replacing of power poles, light poles and telephone poles shall be done in accordance with Utility Owners Standards and all expenses shall be paid for by the Contractor. All arrangements for relocations with the Utility Company Owners shall be done by the Contractor at least 72 hours prior to need for relocations.

21. TELEPHONE

An emergency telephone system (listing of number) shall be set up and given to the Engineer and Owner so that the Contractor may be immediately notified of any unsafe conditions or emergencies encountered during times that the Contractor is not working on the project.

The Contractor shall provide a local number and a local employee so that he may be contacted at any time (including weekends and holidays) 24 hours a day.

22. EXISTING PRIVATE FACILITIES

Existing wells, septic tank, tile field, lawn sprinklers or other facilities disturbed or damaged by the Contractor shall be repaired and restored to working condition before the end of that working day. Under no circumstances will such interruptions be extended overnight. The Contractor shall take necessary precautions not to allow any discharge from the above to enter any lake, stream, or canal along the line of work. Costs for repairs or temporary service caused by the Contractor shall be at his own expense and no claims for extra work will be allowed.

All precautions necessary shall be taken to ensure no damage occurs to homes, including basements.

23. MAIL BOXES

The Contractor shall temporarily relocate mailboxes interfering with construction so that mail service is not interrupted. Mailboxes shall be replaced in a condition, elevation, and location equal to that existing prior to construction in accordance with U.S. Post Office requirements. Costs are incidental.

24. MATERIAL TESTING

The Owner reserves the right to sample and test any of the materials required for the proposed construction, either before or after delivery to the project and to reject any material represented by any sample which fails to comply with the minimum requirements specified.

The Contractor shall furnish all materials reasonably required for sample testing and analysis necessary for the testing of materials as required by these specifications.

The cost of the above testing shall be paid for by the Owner. If any pipe fails to meet the specified requirements, all pipe represented by the sample shall be rejected unless the Contractor can demonstrate through additional tests, at his own expense, that the remainder of the pipe is satisfactory.

As a minimum requirement, the following shall be submitted to the Engineer by the Contractor (at no extra cost to the Owner).

A. Gravels: A gradation analysis.

25. COORDINATION

The Contractor shall coordinate construction with the Owner and Engineer. Contractor shall attend periodic coordination meetings scheduled by the Engineer as necessary.

26. RECORD PLANS

The Contractor shall maintain a set of record drawings throughout the project. The Contractor shall make the drawings available to the Owner and Engineer in a timely manner upon request. A set of record drawings shall be submitted to the Engineer at the completion of the project.

27. WATER SERVICE POTHOLING

Owner records indicate that some service lines are of known materials. These known service lines will not require potholing investigation. Contractor shall expose unknown water service at the water main connection and approximately 3' from the curb box on each side for viewing by the Authorized Representative and for a ford box, if present, starting approximately 3' from the ford box along the private line toward the house, until the private line coupling is observed. It is up to the Contractor whether this is done by vactor truck or open excavation. Some service materials are

known for yard and unknown from main to curb box. However, potholing will be paid for one each per house whether yard or street or private line is known or unknown or any combination. This item shall include restoration of the pothole. Hard surface restoration will be paid separately as **Road or Driveway Remove & Replace COK (Exhibit B)**. Backfilling of the pothole shall take place immediately after viewing and data collection by the Authorized Representative.

28. WATER SERVICE SHORT & LONG

This item includes replacement of the water service from the water main (including new tap) to the curb box including the curb box. Removal and replacement of road or driveway cross-section shall be paid for under item road removal and replacement (See attached Exhibits A, B, and C). Sidewalk removal and replacement is to be paid separately. Contractor may bore service if desired. This item shall include lawn restoration as well. Distinction of long and short is simply if the water main is on the house side of the road it's a short service. If the water main is on the far side of the road it's a long service.

29. WATER SERVICE YARD

This item includes replacement of the water service from the curb box to the meter not including the curb box or the meter. This item does not anticipate asphalt or concrete removal. Pavement removal and replacement is to be paid for separately. Sidewalk removal and replacement is to be paid separately. Contractor may bore service if desired. This item shall include lawn restoration.

30. WATER SERVICE PRIVATE

This item includes the replacement of the water service from a curb box into the house. This item does not anticipate asphalt or concrete removal. Pavement removal and replacement is to be paid for separately. Contractor should bore service if able. This item shall include lawn restoration. A plumber may be required to finalize the connection in the house. Type k copper shall be used for the pipe underground. A flare copper to male iron pipe fitting and ball valve shall be used just inside the exterior wall of the house. For 0.75" use Ford C28-33-NL. For 1.25" use Ford C28-55-NL.

31. 2" SERVICE

This item refers to the service between the water main and the meter setting no greater than 58 feet in length, including the tap. Pavement removal and replacement is to be paid for separately. Contractor may bore service if desired. This item shall include lawn restoration. Copper Tubing, Additional Length, 2" refers to the additional copper tubing and work needed when services exceed 58 feet in length. See standard details WA-07-A, WS-9-A.

32. 2" METER VAULT

This item refers to all labor and materials to install a meter vault for a 2" Service as shown in detail WS-1-A. Pavement removal and replacement is to be paid for separately. This item shall include lawn restoration.

33. ABANDON BLIND

This item includes all labor and materials required to excavate to and turn off the blind service line at the water main, cut, and sever the service connection from the water main. This item also includes backfill. Pavement removal and replacement is to be paid for separately. All blinds located by City Utility Locators shall be cut. The quantity in the bid proposal is an estimate, payment will be made on actual quantities.

34. PLUMBER

This item includes all labor and materials required to connect either the meter to the existing private plumbing in the house or to connect the Water Service Private to the existing private plumbing in the house. This work shall be completed by a plumber who is licensed in the State of Michigan. This item shall also include meter setting. Meters and remotes will be supplied by the City. The new meter shall be sized to match the existing. This item includes removing the old meter and providing to the Inspector, installing the new meter, ground clamps, ground wire, and remote to the outside of the building or ford box lid. Provide the meter and remote stickers to the Inspector. See details WS-5-A for inside meter setting and WSS-7-A for ford box meter setting.

Interior meter setter: for 5/8": Ford C38-13-2-188-NL; for 1": Ford C38-4-2-625-NL

Ball valve: Apollo 94ALF-105-01A

Ground wire: #6 AWG, stranded, bare copper grounding wire

Ground wire clamps: Cast bronze ground clamp for use with stranded ground wire and sized to match the service size.

Remote wire: Agave Wire TIN22-3SOLRGB Solid Strand Meter Cable, 22 to 3 AWG, PVC, Red/Black/Green, or approved equal.

The complete work as described will be measured and paid for as Plumber, HR.

35. WATER FILTER

Contractor shall supply one faucet mount water filter to each house where water service work takes place. Water filter shall be tested and certified to NSF/ANSI 53 to ensure they reduce contaminants, including lead, per the requirements of the standards. Water filter shall be PUR faucet unit Model No. FM2000B or FM3333B, or approved equal.

36. CURB VALVE

This item is utilized when the existing street service is copper, but the curb valve is leaking or not operational. This item includes all labor and materials to replace the curb valve according to the Standard Specifications. The complete work as described will be measured and paid for as Curb Valve, EA.

37. CURB BOX

This item is utilized when the existing service is found to be copper and the curb box is damaged and in need of replacement. This item includes all labor and materials to replace the curb box according to the Standard Specifications. The complete work as described will be measured and paid for as Curb Box, EA.

38. MISCELLANEOUS REPAIR ALLOWANCE

This allowance is for minor repairs for unique installations that may require demolition and repair in the house more than the typical installation. The contractor must notify the inspector prior to any work being performed under the allowance. The contractor shall provide a cost estimate that is approved by the Engineer and Owner prior to work being performed. Actual costs for the work will be paid with an allowable 5% markup for specialty sub-contractors.

39. LAWN RESTORATION

This item includes all work necessary to return the area of construction operations to its original or better condition, other than the items listed in the Proposal, shall be considered incidental to the construction, and no specific payment will be made therefor.

Initial restoration (rough grading, temporary aggregate if necessary, removal of excess excavated material and debris) shall be done each day to the extent necessary to allow the movement of local traffic and permit access to all properties for emergency vehicles. Maintenance of streets, drives, sidewalks, etc. shall be the responsibility of the Contractor (including dust control, grading, stabilization, etc.) until the restoration is complete and has been accepted by the Engineer.

Restoration of each street or section of utility line shall follow the construction in a timely fashion so as to minimize inconvenience to the adjacent property owners and the general public. The manner in which this restoration is done by the Contractor will be a determining factor in the approval by the Engineer of staking requests and partial payment requests

A. Underground Sprinkling Equipment

Underground sprinkling lines, valves & heads, and water system curb stops and boxes are specifically excluded from the pay items. The Contractor shall take the necessary precautions to preserve this equipment during construction. Any underground sprinkling equipment disturbed by the Contractor shall be replaced at the Contractor's expense.

All underground sprinkling equipment shall be replaced in a timely fashion so as to minimize damage to the lawn areas. The Contractor will be responsible for any lawn damage caused by delayed replacement of the sprinkling equipment.

B. Fences

Fences, which are removed for construction, shall be replaced with equal or better type and size. The cost of removing and replacing the fences shall be considered part of the major items of work found in the Proposal unless otherwise specified

C. Ornamental Shrubbery and Bushes

Ornamental shrubbery and bushes that are removed during construction shall be replaced in kind and size in a vigorous growing condition. Replacement costs shall be considered part of the major items of work found in the Proposal unless otherwise specified. All shrubs and bushes replaced shall be insured by a one-(1) year warranty commencing from the date of installation.

D. Turf Restoration

All areas of established turf shall be replaced as nearly as possible to their original or better condition. Lawns shall be protected and maintained by watering, mowing, and reseeding as necessary, until the period of time when the final acceptance and payment is made by the Engineer for the project, to establish a uniform, weed-free, stand of the specified grasses. The cost shall be considered part of the major items of work found in the Proposal.

- Topsoil

Topsoil shall be placed at a minimum depth of four (4) inches over all areas disturbed by the Contractor's operations. The subgrade shall be graded to conform to the adjacent contours and shall be approved by the Engineer before placing topsoil. The topsoil shall then be placed in accordance with Section 816 of the MDOT 2012 Standard Specifications for Construction.

The soil shall be dark, organic natural surface soil, exclusive of muck or peat, suitable for the establishment of grass or other vegetable growth.

- Fertilizer

After the topsoil has been placed, it shall be fertilized with a starter fertilizer at the rate of two (2) pounds per 1,000 square feet, in proportions of 16% nitrogen, 32% phosphoric acid, and 3% potash, or as directed by the Engineer. Fertilizer shall be applied just before the placing of the seed to retain its full benefit before unfavorable weather can cause deterioration.

- Seeding

All previously seeded lawn areas shall be reseeded with MDOT THM seed (Table 917-1). Other areas disturbed by the Contractor's operations shall be seeded with MDOT TUF seed. Temporary seed shall be placed for erosion

control or temporary soil stabilization of stockpile areas. Seed mixtures, application rates, and methods shall be in accordance with Section 816 of the MDOT 2012 Standard Specifications for Construction.

Seasonal limitations on seeding in Section 816 of the MDOT 2012 Standard Specifications for Construction are waived. The Contractor shall repeat the seeding procedure as often as necessary to produce a close stand of weed-free grass

- Mulching
All seeded areas shall be mulched immediately following the seeding. Mulching shall be applied to all newly seeded areas at a rate of two (2) tons per acre in accordance with the requirements of Section 816 of the MDOT 2012 Standard Specifications for Construction, or as directed by the Engineer.
- Hydro Application
All fertilizing, seeding and mulching shall be applied by an approved Hydro seeding and mulching process unless separate applications as heretofore described are approved by the Engineer.
- Erosion Control
All erosion control measures shall be installed and maintained in accordance with the Soil Erosion and Sedimentation Control plan and permit. Unless otherwise specified, mulch blanket and high velocity blanket shall be placed in accordance with Section 816 of the MDOT 2012 Standard Specifications for Construction.

Net erosion blankets containing plastic or synthetic net or netting shall no longer be authorized, purchased, nor approved for use. Only Erosion Control Blankets such as North American Green Bionet S150BN, and Western Wood fibers EXCEL SS-2 All Natural (biodegradable jute/scrim netting with leno weave type mesh), or equivalent, are considered acceptable products. Loose straw is acceptable, where applicable.

- Sod
Sod shall be placed only where directed by the Engineer or as noted on the drawings or specifications.

All sod shall be nursery grown, conforming to MDOT requirements for Class A. Sod shall be approved by the Engineer before placing and shall be placed in accordance with the requirements of Section 816 of the MDOT 2012 Standard Specifications for Construction. The base on which the sod is to be laid shall consist of a minimum of four (4) inches of topsoil placed, watered and fertilized in the same manner required for seeding

40. PAVEMENT REMOVAL AND REPLACEMENT

This work consists of removing and replacing HMA, concrete, masonry, and other common pavement material, except sand and gravel, regardless of thickness, reinforcement, and overlays.

The materials shall be HMA 13A, HMA, MDOT 4E, HMA, MDOT 5E, Concrete, Grade P1; and Concrete S2. The pavement shall be removed to an existing joint or sawed joint. Saw cut pavement full depth in a straight neat line as directed by the Engineer. Do not use a crane and ball pavement breaker. Do not disturb remaining pavement. Assume ownership of removed materials and dispose of according to MDOT 2012 Standard Specifications for Construction subsection 205.03P.

After completion of the utility work, replace subgrade, subbase, and aggregate base in accordance with Michigan Department of Transportation Standard Plan for utility trenches R-83-Series. Replace sidewalk, driveway, and pavement matching existing materials. Replacement of brick roadway shall be completed with integrally colored concrete and stamped with the "Pennsylvania Avenue Brick Running Bond" pattern. The completed work, as described, will be measured and paid for at the contract unit price using the following pay items:

- Sidewalk Remove & Replace
- Curb Remove & Replace
- Road or Driveway Remove & Replace COK (Exhibit A)
- Road or Driveway Remove & Replace COK (Exhibit B)
- Road or Driveway Remove & Replace RCKC (Exhibit C)
- HMA Driveway Remove & Replace
- Stamp Concrete
- HMA 13A
- HMA, MDOT 4E
- HMA, MDOT 5E
- Milling, 2"
- Milling, 1.5"

The limits of the construction will be established at the discretion of the Engineer. Payment shall be based on the saw cut limits. The unit price includes all labor, equipment, and materials to saw cut, remove, haul, dispose of the pavement. All other material removal and replacement shall be included with other contract items. There will be sections of City of Kalamazoo streets where a lane width will be required to be milled and repaved to a depth of 1.5" for entire blocks. These sections will be determined during construction and communicated to the Contractor. Estimated quantities are in the bid proposal.

41. PAYMENT

Payment shall be made for the proposal items only. All of the work specified above and indicated on the drawings shall be considered included in the unit prices shown on the proposal. Work for a single address shall not be included in the monthly pay application until all work is completed at that address. The City has developed a shared one-drive spreadsheet and will provide this to the Contractor awarded the contract. The Contractor is responsible to coordinate with the Consultant for **DAILY** updates to the spreadsheet. The Contractor is responsible to provide all information necessary to the Project Inspector for the completion of the service card as-builts.

Definitions of abbreviations for measurement/payment:

LF	=	Lineal Foot
EA	=	Each
VF	=	Vertical Foot
LS	=	Lump Sum
CY	=	Cubic Yard
SY	=	Square Yard
SF	=	Square Foot
TON	=	Tonnage



CITY OF KALAMAZOO
DEPARTMENT OF PUBLIC SERVICES
ENGINEERING

CITY OF KALAMAZOO STANDARD STREETS DETAILS

City of Kalamazoo

INDEX OF SHEETS

- 1 STANDARD DETAILS FOR SIDEWALK AND STREETS
- 2 TYPICAL CUTS FOR UTILITIES AND STREETS
- 3-4 FULL/PARTIAL WIDTH MILL AND FILL GUIDELINES
- 5 ADJUSTING DRAINAGE STRUCTURE - MDOT_20SP-430A-02
18" CORE / HYDROVAC FOR EXPOSING UTILITY
BRICK STREET STANDARD DETAIL
LOCAL STREETS - WINTER CUT DETAIL

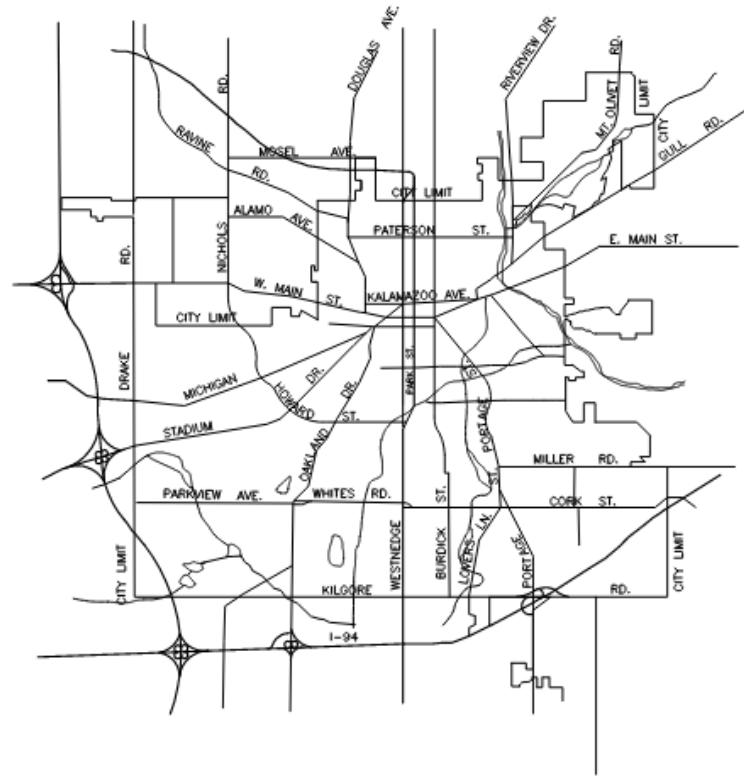

ROW PERMIT
EXTERNAL
CONTRACTORS



ROW PERMIT
COK INTERNAL



Know what's below.
Call before you dig.
www.missdig.net



MDOT STANDARD BRIDGE PLANS



MDOT STANDARD ROAD PLANS

APPROVAL	
CITY OF KALAMAZOO, MICHIGAN	
JAMES J. BAKER, PE PUBLIC SERVICES DIRECTOR & CITY ENGINEER	01/01/2025 DATE

**STANDARD DETAIL - SIDEWALK
ROOT AVOIDANCE - MEANDERING SIDEWALK**

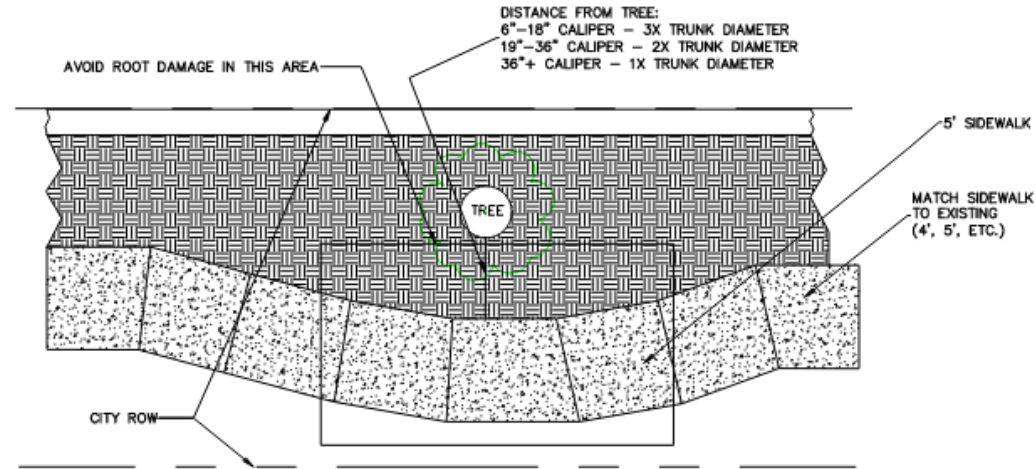

ROOT CRACKING OF SIDEWALK

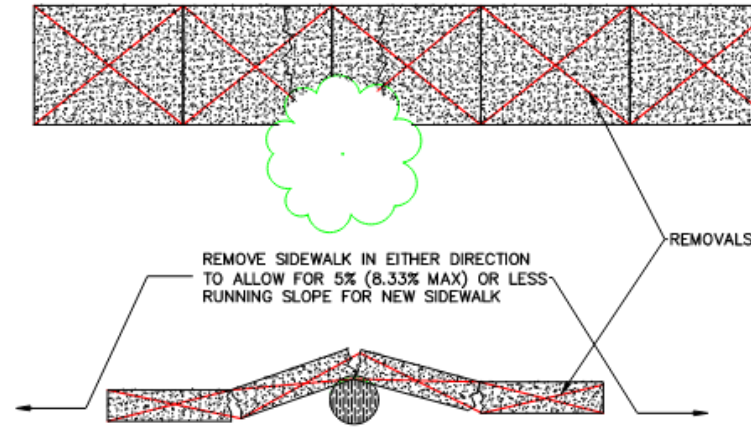

DEPARTMENT OF PUBLIC SERVICES - Engineering
STANDARD DETAILS - SHEET 1
CITY OF KALAMAZOO

DESIGNED: GHW / JUB	SCALE:
DRAWN: GHW / WJE	VERTICAL: NOT TO SCALE
CHECKED: JUB	HORIZONTAL: NOT TO SCALE
	DATE: 01/01/2022

- GENERAL NOTES:**
- MDOT STANDARD PLANS R-28-K, R-29-J, R-30-G, AND R-44-F SHALL BE FOLLOWED IN CONJUNCTION WITH THESE STANDARD PLANS
 - ALL SAW CUTTING SHALL BE DONE PERPENDICULAR AND PARALLEL TO THE DIRECTION OF TRAVEL
 - SAW CUTTING SHALL PROVIDE A STRAIGHT, CLEAN, EDGE TO ENHANCE BONDING
 - ALL CUTS SHALL BE RECTANGULAR AND NEATLY CUT TO AVOID SPALLING OF PAVEMENT
 - IN GENERAL ALL ROAD/UTILITY CUTS OF AN AREA GREATER THAN 9SFT (3FTX3FT TYPICAL) SHALL EXTEND THE FULL WIDTH OF THE TRAVEL LANE FOR PAVEMENT WITH LOAD TRANSFER DOWEL RODS OR REINFORCEMENT: NEW LOAD TRANSFER DOWELS/REINFORCEMENT SHALL BE PLACED TO MAINTAIN BEARING CAPACITY OF ROADWAY
 - CUTS LESS THAN 12" SHALL BE PATCHED WITH PCC. IF GREATER THAN 12", ENSURE CUT IS IN ACCORDANCE WITH STANDARD DETAILS AND MATCHING EXISTING ROADWAY
 - BUMPS/CUTS/MILLED AREAS WITH EDGE GREATER THAN 2" DEEP/HIGH MUST BE WEDGED WITH HMA BEFORE OPEN TO TRAFFIC. SEE STANDARD DETAIL.
 - MEANDERING SIDEWALK SHALL ONLY BE PLACED IN THE CITY'S ROW OR WHERE AN EASEMENT IS ESTABLISHED
 - NEW SIDEWALK CONSTRUCTION SHALL MEET OR EXCEED CURRENT ADA AND ACCESSIBILITY STANDARDS
 - REPLACED SIDEWALK SHALL, TO THE EXTENT PRACTICABLE, MEET OR EXCEED ADA AND ACCESSIBILITY STANDARDS
 - SIDEWALK, DRIVEWAY OPENINGS & APPROACHES SHALL CONFORM TO MDOT STANDARD PLAN DETAILS R-28-K AND R-29-J
 - MARSHALL MIX 36/13A (TOP/LEVELING) MAY BE SUBSTITUTED FOR HMA MIX DESIGNS WITH CITY OF KALAMAZOO APPROVAL IF DEEMED APPROPRIATE BY THE ENGINEER
 - ASPHALT BINDER SHALL BE INCLUDED IN THE PAY ITEM FOR HMA
 - MDOT PCC 3500 MIX DESIGN SHALL BE USED FOR ALL CONCRETE UNLESS OTHERWISE STATED OR DIRECTED BY THE ENGINEER
 - OPENING TO TRAFFIC STRENGTHS (2020 STANDARD SPECIFICATIONS FOR CONSTRUCTION, TABLE 603-1):
 - < 72 HOURS, GRADE P-NC, 300 psi
 - 72 HOURS +, GRADE 3500/HP, 550 psi

**STANDARD DETAIL -
SIDEWALK ROOT AVOIDANCE**

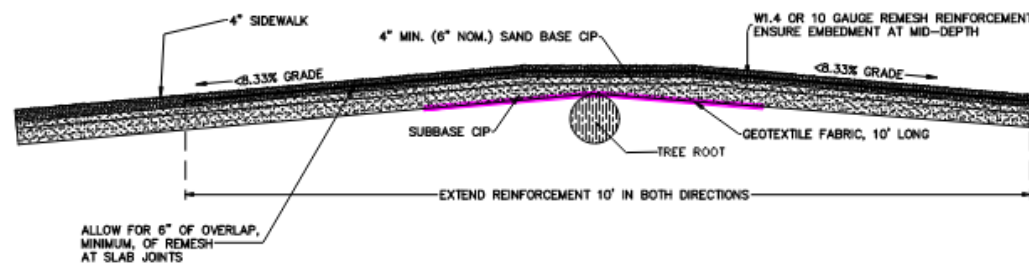

**STANDARD DETAIL - WEDGING
CUT / MILLED SECTION**

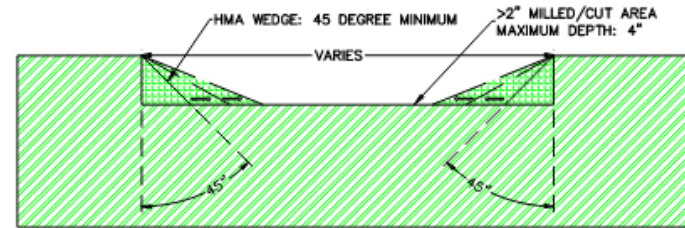

**STANDARD DETAIL - SIDEWALK ROOT AVOIDANCE
WITHOUT REINFORCEMENT
(USE ONLY AS DIRECTED BY ENGINEER)**

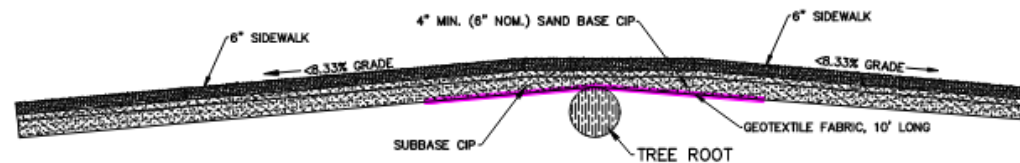

STANDARD DETAIL - LOW VOLUME / RESIDENTIAL ROADS PERFORATED PIPE DETAIL

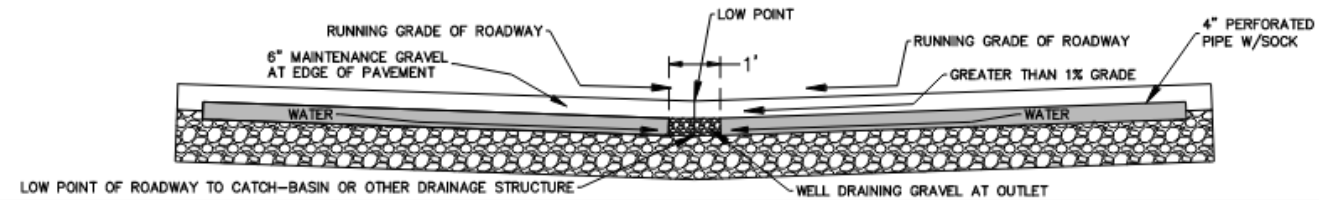

TYPICAL 4" SIDEWALK DETAIL

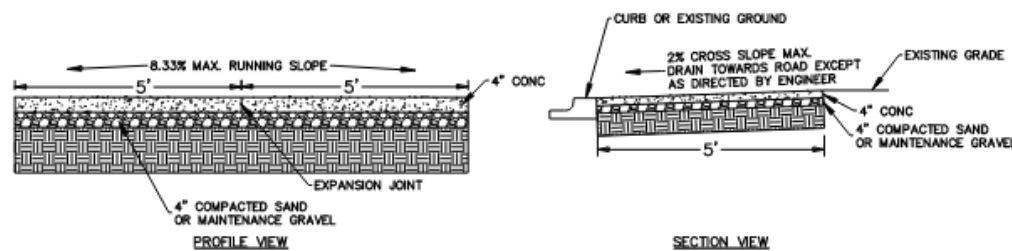

STANDARD DETAIL - LOW VOLUME / RESIDENTIAL ROADS - POORLY DRAINED AREAS

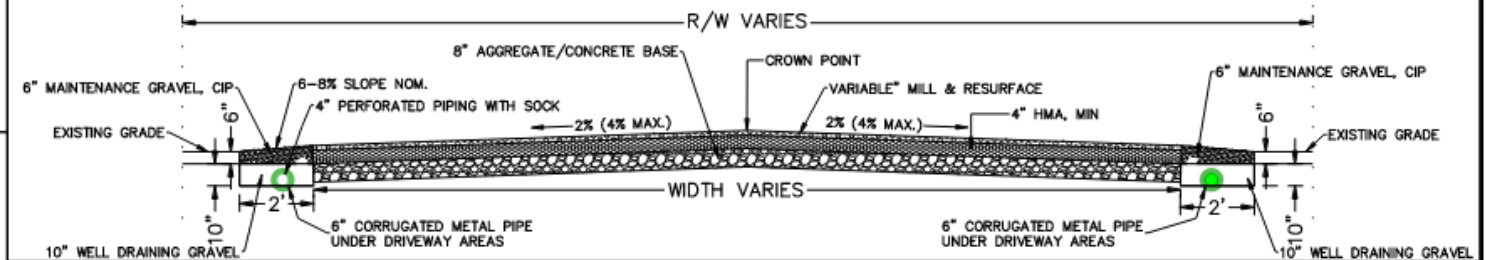

STANDARD DETAIL - LOW VOLUME / RESIDENTIAL ROADS - EASILY DRAINED AREAS

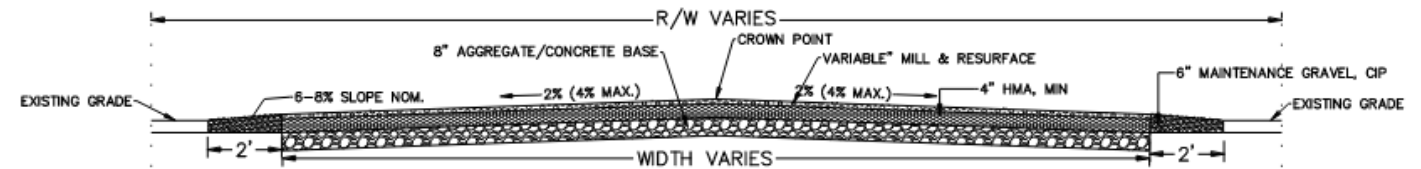

EXHIBIT A

<p style="text-align: center;">ASPHALT WITH CONCRETE BASE TRENCH DETAIL</p> <p style="text-align: right; font-size: small;">APPLIES TO: CITY MAJOR ROADS COMMERCIAL ROADS HIGH VOLUME ROADS</p> <p style="font-size: small;">REMOVE AND REPLACE ASPHALT/CONCRETE MINIMUM 2' PAST CUT LOCATION</p> <p style="font-size: small;">SAW CUT OR NEATLY TRIM EDGE WITH AIR HAMMER</p> <p style="font-size: small;">1-1/2" MDOT 5E HMA TOP COURSE</p> <p style="font-size: small;">2" MDOT 4E HMA LEVELING COURSE</p> <p style="font-size: small;">6" CONCRETE BASE COURSE</p> <p style="font-size: small;">12" 21AA COMPACTED AGGREGATE BASE COMPACTED TO 98% DENSITY</p> <p style="font-size: small;">MDOT CLASS II GRANULAR MATERIAL COMPACTED IN 12" LIFTS TO 95% DENSITY</p> <p style="font-size: small;">UNLESS OTHERWISE NOTED: COVER THICKNESS SHALL BE THE GREATER OF 30" OR 1/2 DIAMETER OF UTILITY PIPE</p> <p style="font-size: small;">NOTE: 1. CUT SHALL BE PARALLEL OR PERPENDICULAR TO EDGE OF ROADWAY/GUTTER 2. FOR POTHOLES 12" DIAMETER AND SMALLER - ALL CONCRETE 3. FOR RESTORATION TOO SMALL TO FIT A PLATE COMPACTOR, HAND COMPACT LAYERS AS SHOWN AND FINISH WITH CONCRETE</p>	<p style="text-align: center;">RESIDENTIAL / LOW TRAFFIC VOLUME ROAD ASPHALT UTILITY TRENCH DETAIL</p> <p style="text-align: right; font-size: small;">APPLIES TO: RESIDENTIAL ROADS CITY LOCAL ROADS LOW-VOLUME ROADS</p> <p style="font-size: small;">REMOVE AND REPLACE ASPHALT/CONCRETE MINIMUM 2' PAST CUT LOCATION</p> <p style="font-size: small;">SAW CUT OR NEATLY TRIM EDGE WITH AIR HAMMER</p> <p style="font-size: small;">1.5-2" HMA, 36A OR MDOT MIX TOP COURSE</p> <p style="font-size: small;">2-4" HMA, 13A OR MDOT MIX @ MINIMUM APPLICATION RATE OF 220#/SYD, BASE/LEVELING COURSE</p> <p style="font-size: small;">8" 21AA COMPACTED AGGREGATE BASE COMPACTED TO 98% DENSITY</p> <p style="font-size: small;">UNLESS OTHERWISE NOTED: COVER THICKNESS SHALL BE THE GREATER OF 30" OR 1/2 DIAMETER OF UTILITY PIPE</p> <p style="font-size: small;">MDOT CLASS II GRANULAR MATERIAL COMPACTED IN 12" LIFTS TO 95% DENSITY</p> <p style="font-size: small;">NOTE: 1. CUT SHALL BE PARALLEL OR PERPENDICULAR TO EDGE OF ROADWAY/GUTTER 2. *SS-1H @ 0.10/GAL/SYD BETWEEN LIFTS 3. PERFORMANCE GRADE BINDER TO BE USED: PG 64-28</p>	<p style="text-align: center; font-size: small;">DEPARTMENT OF PUBLIC SERVICES - Engineering</p> <p style="text-align: center; font-size: small;">STANDARD DETAILS - SHEET 2</p> <p style="text-align: center; font-size: small;">CITY OF KALAMAZOO</p> <table border="1" style="width: 100%; border-collapse: collapse; font-size: x-small;"> <tr> <td style="width: 33%;">DESIGNED: GHW / JUB</td> <td style="width: 33%;">SCALE:</td> <td style="width: 33%;"></td> </tr> <tr> <td>DRAWN: GHW / WEE</td> <td>VERTICAL: NOT TO SCALE</td> <td></td> </tr> <tr> <td>QA/QC: JUB</td> <td>HORIZONTAL: NOT TO SCALE</td> <td></td> </tr> <tr> <td></td> <td>DATE: 01/20/2025</td> <td></td> </tr> </table> <p style="font-size: small;">GENERAL NOTES: - MDOT STANDARD PLANS R-28-K, R-29-J, R-30-G, AND R-44-F SHALL BE FOLLOWED IN CONJUNCTION WITH THESE STANDARD PLANS - ALL SAW CUTTING SHALL BE DONE PERPENDICULAR AND PARALLEL TO THE DIRECTION OF TRAVEL - SAW CUTTING SHALL PROVIDE A STRAIGHT, CLEAN, EDGE TO ENHANCE BONDING - ALL CUTS SHALL BE RECTANGULAR AND NEATLY CUT TO AVOID SPALLING OF PAVEMENT - IN GENERAL ALL ROAD/UTILITY CUTS OF AN AREA GREATER THAN 9SF (3FTX3FT TYPICAL) SHALL EXTEND THE FULL WIDTH OF THE TRAVEL LANE FOR PAVEMENT WITH LOAD TRANSFER DOWEL RODS OR REINFORCEMENT: NEW LOAD TRANSFER DOWELS/REINFORCEMENT SHALL BE PLACED TO MAINTAIN BEARING CAPACITY OF ROADWAY - CUTS LESS THAN 12" SHALL BE PATCHED WITH PCC. IF GREATER THAN 12", ENSURE CUT IS IN ACCORDANCE WITH STANDARD DETAILS AND MATCHING EXISTING ROADWAY - BUMPS/CUTS/MILLED AREAS WITH EDGE GREATER THAN 2" DEEP/HIGH MUST BE WEDGED WITH HMA BEFORE OPEN TO TRAFFIC. SEE STANDARD DETAIL - MEANDERING SIDEWALK SHALL ONLY BE PLACED IN THE CITY'S ROW OR WHERE AN EASEMENT IS ESTABLISHED - NEW SIDEWALK CONSTRUCTION SHALL MEET OR EXCEED CURRENT ADA AND ACCESSIBILITY STANDARDS - REPLACED SIDEWALK SHALL, TO THE EXTENT PRACTICABLE, MEET OR EXCEED ADA AND ACCESSIBILITY STANDARDS - SIDEWALK, DRIVEWAY OPENINGS & APPROACHES SHALL CONFORM TO MDOT STANDARD PLAN DETAILS R-28-K AND R-29-J - MARSHALL MIX 36/13A (TOP/LEVELING) MAY BE SUBSTITUTED FOR HMA MIX DESIGNS WITH CITY OF KALAMAZOO APPROVAL IF DEEMED APPROPRIATE BY THE ENGINEER - ASPHALT BINDER SHALL BE INCLUDED IN THE PAY ITEM FOR HMA - MDOT PCC 3500 MIX DESIGN SHALL BE USED FOR ALL CONCRETE UNLESS OTHERWISE STATED OR DIRECTED BY THE ENGINEER - OPENING TO TRAFFIC STRENGTHS (2020 STANDARD SPECIFICATIONS FOR CONSTRUCTION, TABLE 603-1): -- <72 HOURS, GRADE P-NC, 300 psi -- 72 HOURS +, GRADE 3500/HP, 550 psi</p>	DESIGNED: GHW / JUB	SCALE:		DRAWN: GHW / WEE	VERTICAL: NOT TO SCALE		QA/QC: JUB	HORIZONTAL: NOT TO SCALE			DATE: 01/20/2025	
DESIGNED: GHW / JUB	SCALE:													
DRAWN: GHW / WEE	VERTICAL: NOT TO SCALE													
QA/QC: JUB	HORIZONTAL: NOT TO SCALE													
	DATE: 01/20/2025													
<p style="text-align: center;">COMMERCIAL ROAD ASPHALT UTILITY TRENCH DETAIL</p> <p style="text-align: right; font-size: small;">APPLIES TO: CITY MAJOR ROADS COMMERCIAL ROADS HIGH VOLUME ROADS</p> <p style="font-size: small;">REMOVE AND REPLACE ASPHALT/CONCRETE MINIMUM 2' PAST CUT LOCATION</p> <p style="font-size: small;">SAW CUT OR NEATLY TRIM EDGE WITH AIR HAMMER</p> <p style="font-size: small;">2-2.5" MDOT 4E HMA LEVELING COURSE</p> <p style="font-size: small;">1.5-2" MDOT 5E HMA TOP COURSE</p> <p style="font-size: small;">MDOT 2E OR 3E APPLIED AT: 330#/SYD MINIMUM FOR 3E 435#/SYD MINIMUM FOR 2E HMA BASE COURSE</p> <p style="font-size: small;">12" 21AA COMPACTED AGGREGATE BASE COMPACTED TO 98% DENSITY</p> <p style="font-size: small;">MDOT CLASS II GRANULAR MATERIAL COMPACTED IN 12" LIFTS TO 95% DENSITY</p> <p style="font-size: small;">UNLESS OTHERWISE NOTED: COVER THICKNESS SHALL BE THE GREATER OF 30" OR 1/2 DIAMETER OF UTILITY PIPE</p> <p style="font-size: small;">NOTE: 1. CUT SHALL BE PARALLEL OR PERPENDICULAR TO EDGE OF ROADWAY/GUTTER 2. *SS-1H @ 0.10/GAL/SYD BETWEEN LIFTS 3. PERFORMANCE GRADE BINDER TO BE USED: PG 64-28 4. HEAVY COMMERCIAL ADT COULD WARRANT CHANGE TO DESIGN.</p>	<p style="text-align: center;">TYPICAL CUT USING PCC TO FILL (WINTER CUT)</p> <p style="text-align: right; font-size: small;">APPLIES TO: CITY MAJOR / LOCAL ROADS COMMERCIAL ROADS HIGH / LOW VOLUME ROADS WINTER ROAD CUTS (SURFACE TEMP BELOW 35F) AND / OR NO PLANT MIX HMA IS AVAILABLE</p> <p style="font-size: small;">REMOVE AND REPLACE ASPHALT/CONCRETE MINIMUM 2' PAST CUT LOCATION</p> <p style="font-size: small;">REPLACE REINFORCING TIE BARS (IF APPLICABLE)</p> <p style="font-size: small;">SAW CUT OR NEATLY TRIM EDGE WITH AIR HAMMER</p> <p style="font-size: small;">NOTE: 9" MIN. THICKNESS: MAJOR STREETS 6" MIN. THICKNESS: MINOR/LOCAL STREETS MDOT-P-NC CONCRETE PAVEMENT REFER TO NOTES FOR MIN. FLEXURAL STRENGTH REQUIRED TO OPEN TO TRAFFIC</p> <p style="font-size: small;">12" MIN. OF 21AA AGGREGATE BASE COMPACTED IN 6" LIFTS. USE 6 PASSES OF A LARGE VIBRATORY PLATE COMPACTOR OR STEEL DRUM ROLLER WITH VIBRATORY CAPABILITIES. NOMINALLY 98% DENSITY</p> <p style="font-size: small;">MDOT CLASS II GRANULAR MATERIAL COMPACTED IN 12" LIFTS. USE 6 PASSES WITH VIBRATORY PLATE COMPACTOR TO ENSURE PROPER DENSITY BETWEEN LIFTS. NOMINALLY 95% DENSITY</p> <p style="font-size: small;">UNLESS OTHERWISE NOTED: COVER THICKNESS SHALL BE THE GREATER OF 30" OR 1/2 DIAMETER OF UTILITY PIPE</p> <p style="font-size: small;">NOTE: 1. CUT SHALL BE PARALLEL OR PERPENDICULAR TO EDGE OF ROADWAY/GUTTER 2. FOR POTHOLES 12" DIAMETER AND SMALLER - ALL CONCRETE 3. FOR RESTORATION TOO SMALL TO FIT A PLATE COMPACTOR, HAND COMPACT LAYERS AS SHOWN AND FINISH WITH CONCRETE</p>													
<p style="text-align: center;">COMMERCIAL ROAD ASPHALT PAVEMENT DETAIL</p> <p style="text-align: right; font-size: small;">APPLIES TO: CITY MAJOR ROADS COMMERCIAL ROADS HIGH VOLUME ROADS</p> <p style="font-size: small;">REFER TO MDOT STANDARD PLAN R-30-G FOR CONCRETE CURB & GUTTER DESIGN</p> <p style="font-size: small;">SAW CUT OR NEATLY TRIM EDGE WITH AIR HAMMER</p> <p style="font-size: small;">1.5-2" MDOT 5E HMA TOP COURSE</p> <p style="font-size: small;">2-2.5" MDOT 4E HMA LEVELING COURSE</p> <p style="font-size: small;">MDOT 2E OR 3E APPLIED AT: 330#/SYD MINIMUM FOR 3E 435#/SYD MINIMUM FOR 2E HMA BASE COURSE</p> <p style="font-size: small;">12" 21AA COMPACTED AGGREGATE BASE COMPACTED TO 98% DENSITY</p> <p style="font-size: small;">MDOT CLASS II GRANULAR MATERIAL COMPACTED IN 12" LIFTS TO 95% DENSITY</p> <p style="font-size: small;">NOTE: 1. *SS-1H @ 0.10/GAL/SYD BETWEEN LIFTS 2. PERFORMANCE GRADE BINDER TO BE USED: PG 64-28</p>	<p style="text-align: center;">ASPHALT PAVEMENT WITH CONCRETE BASE DETAIL</p> <p style="text-align: right; font-size: small;">APPLIES TO: CITY MAJOR ROADS COMMERCIAL ROADS HIGH VOLUME ROADS</p> <p style="font-size: small;">REFER TO MDOT STANDARD PLAN R-30-G FOR CONCRETE CURB & GUTTER DESIGN</p> <p style="font-size: small;">SAW CUT OR NEATLY TRIM EDGE WITH AIR HAMMER</p> <p style="font-size: small;">1-1/2" MDOT 5E HMA TOP COURSE</p> <p style="font-size: small;">2" MDOT 4E HMA LEVELING COURSE</p> <p style="font-size: small;">6" CONCRETE BASE COURSE</p> <p style="font-size: small;">12" 21AA COMPACTED AGGREGATE BASE COMPACTED TO 98% DENSITY</p> <p style="font-size: small;">MDOT CLASS II GRANULAR MATERIAL COMPACTED IN 12" LIFTS TO 95% DENSITY</p> <p style="font-size: small;">NOTE: 1. *SS-1H @ 0.10/GAL/SYD BETWEEN LIFTS 2. PERFORMANCE GRADE BINDER TO BE USED: PG 64-28</p>	<p style="text-align: center;">RESIDENTIAL / LOW TRAFFIC VOLUME ROAD ASPHALT PAVEMENT DETAIL</p> <p style="text-align: right; font-size: small;">APPLIES TO: RESIDENTIAL ROADS CITY LOCAL ROADS LOW-VOLUME ROADS</p> <p style="font-size: small;">REFER TO MDOT STANDARD PLAN R-30-G FOR CONCRETE CURB & GUTTER DESIGN</p> <p style="font-size: small;">SAW CUT OR NEATLY TRIM EDGE WITH AIR HAMMER</p> <p style="font-size: small;">1.5-2" HMA, 36A OR MDOT MIX TOP COURSE</p> <p style="font-size: small;">2-4" HMA, 13A OR MDOT MIX @ MINIMUM APPLICATION RATE OF 220#/SYD, BASE/LEVELING COURSE</p> <p style="font-size: small;">8" 21AA COMPACTED AGGREGATE BASE COMPACTED TO 98% DENSITY</p> <p style="font-size: small;">MDOT CLASS II GRANULAR MATERIAL COMPACTED IN 12" LIFTS TO 95% DENSITY</p> <p style="font-size: small;">NOTE: 1. *SS-1H @ 0.10/GAL/SYD BETWEEN LIFTS 2. PERFORMANCE GRADE BINDER TO BE USED: PG 64-28</p>												

PAVEMENT CUT / PATCHING DETAILS

DESIGNED GHW / JUB		SCALE	
DRAWN GHW / WEL		VERTICAL NOT TO SCALE	
CHECKED JUB		HORIZONTAL NOT TO SCALE	
		DATE 01/01/2025	

DEPARTMENT OF PUBLIC SERVICES - Engineering
STANDARD DETAILS - SHEET 3
CITY OF KALAMAZOO

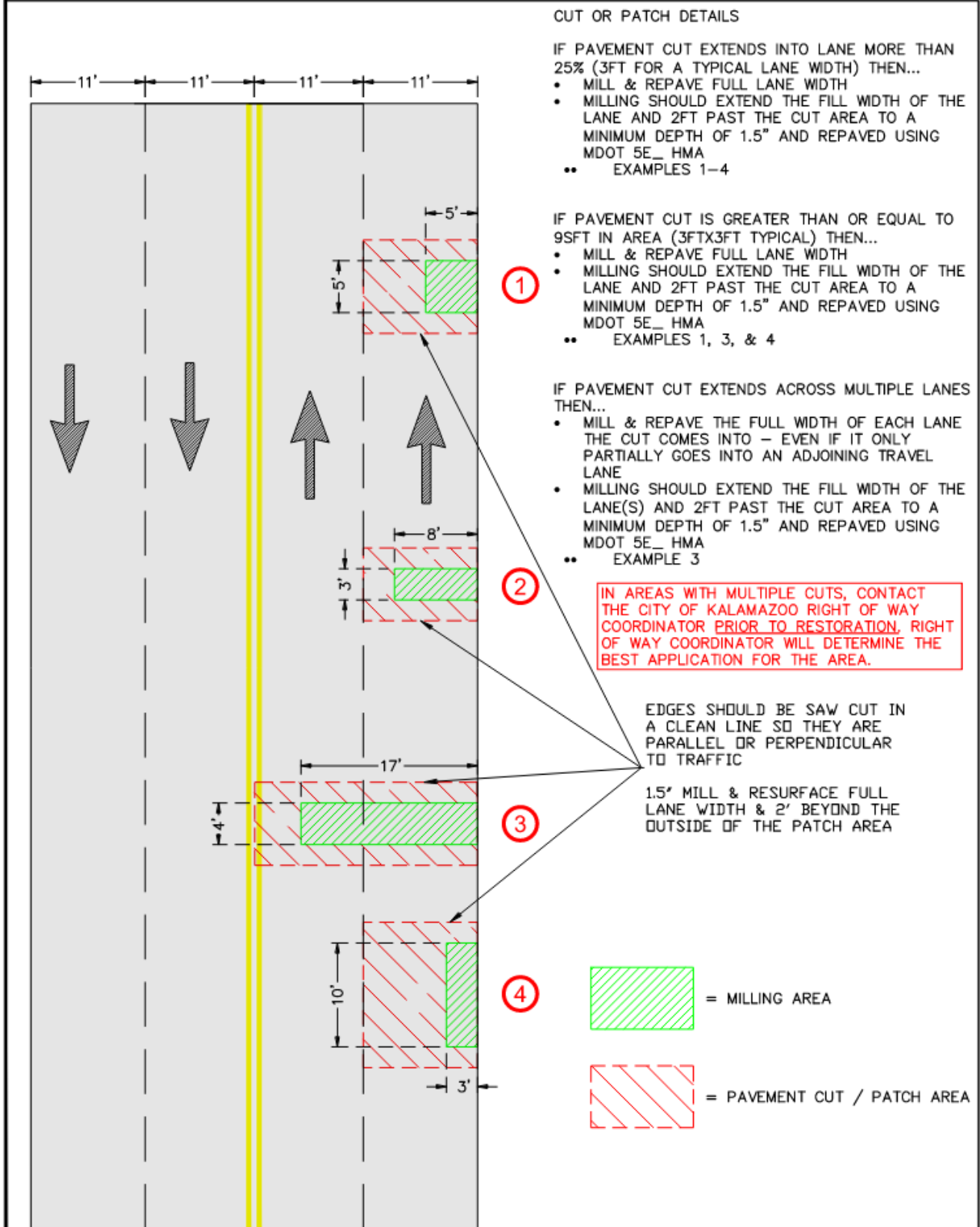

CUT OR PATCH DETAILS

IF PAVEMENT CUT EXTENDS INTO LANE MORE THAN 25% (3FT FOR A TYPICAL LANE WIDTH) THEN...

- MILL & REPAVE FULL LANE WIDTH
- MILLING SHOULD EXTEND THE FILL WIDTH OF THE LANE AND 2FT PAST THE CUT AREA TO A MINIMUM DEPTH OF 1.5" AND REPAVED USING MDOT 5E_ HMA
- EXAMPLES 1-4

IF PAVEMENT CUT IS GREATER THAN OR EQUAL TO 9SFT IN AREA (3FTX3FT TYPICAL) THEN...

- MILL & REPAVE FULL LANE WIDTH
- MILLING SHOULD EXTEND THE FILL WIDTH OF THE LANE AND 2FT PAST THE CUT AREA TO A MINIMUM DEPTH OF 1.5" AND REPAVED USING MDOT 5E_ HMA
- EXAMPLES 1, 3, & 4

IF PAVEMENT CUT EXTENDS ACROSS MULTIPLE LANES THEN...

- MILL & REPAVE THE FULL WIDTH OF EACH LANE THE CUT COMES INTO - EVEN IF IT ONLY PARTIALLY GOES INTO AN ADJOINING TRAVEL LANE
- MILLING SHOULD EXTEND THE FILL WIDTH OF THE LANE(S) AND 2FT PAST THE CUT AREA TO A MINIMUM DEPTH OF 1.5" AND REPAVED USING MDOT 5E_ HMA
- EXAMPLE 3

IN AREAS WITH MULTIPLE CUTS, CONTACT THE CITY OF KALAMAZOO RIGHT OF WAY COORDINATOR PRIOR TO RESTORATION, RIGHT OF WAY COORDINATOR WILL DETERMINE THE BEST APPLICATION FOR THE AREA.

EDGES SHOULD BE SAW CUT IN A CLEAN LINE SO THEY ARE PARALLEL OR PERPENDICULAR TO TRAFFIC

1.5" MILL & RESURFACE FULL LANE WIDTH & 2' BEYOND THE OUTSIDE OF THE PATCH AREA

- = MILLING AREA
- = PAVEMENT CUT / PATCH AREA

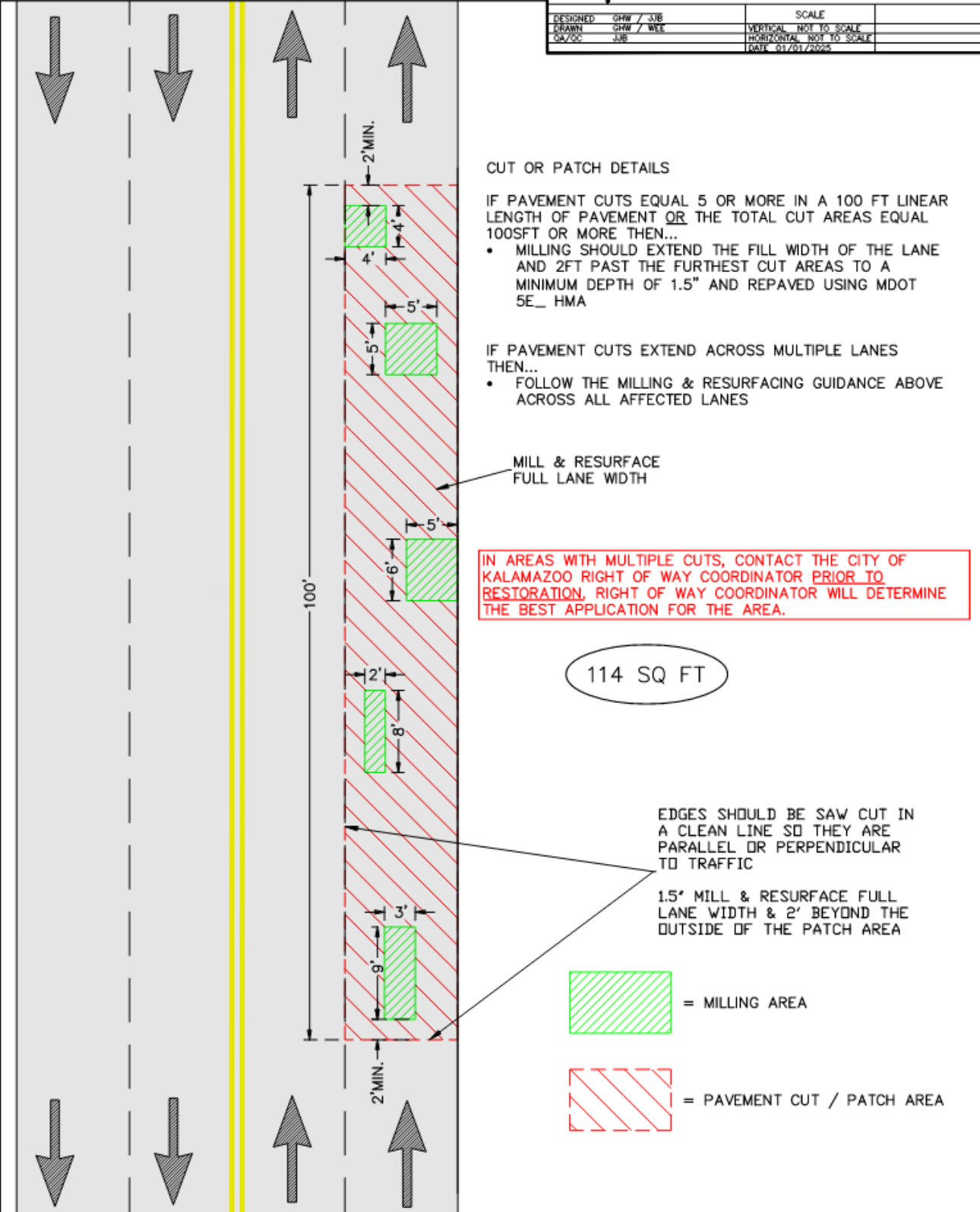

CUT OR PATCH DETAILS

IF PAVEMENT CUTS EQUAL 5 OR MORE IN A 100 FT LINEAR LENGTH OF PAVEMENT OR THE TOTAL CUT AREAS EQUAL 100SFT OR MORE THEN...

- MILLING SHOULD EXTEND THE FILL WIDTH OF THE LANE AND 2FT PAST THE FURTHEST CUT AREAS TO A MINIMUM DEPTH OF 1.5" AND REPAVED USING MDOT 5E_ HMA

IF PAVEMENT CUTS EXTEND ACROSS MULTIPLE LANES THEN...

- FOLLOW THE MILLING & RESURFACING GUIDANCE ABOVE ACROSS ALL AFFECTED LANES

MILL & RESURFACE FULL LANE WIDTH

IN AREAS WITH MULTIPLE CUTS, CONTACT THE CITY OF KALAMAZOO RIGHT OF WAY COORDINATOR PRIOR TO RESTORATION, RIGHT OF WAY COORDINATOR WILL DETERMINE THE BEST APPLICATION FOR THE AREA.

114 SQ FT

EDGES SHOULD BE SAW CUT IN A CLEAN LINE SO THEY ARE PARALLEL OR PERPENDICULAR TO TRAFFIC

1.5" MILL & RESURFACE FULL LANE WIDTH & 2' BEYOND THE OUTSIDE OF THE PATCH AREA

- = MILLING AREA
- = PAVEMENT CUT / PATCH AREA

PAVEMENT CUT / PATCHING DETAILS

DEPARTMENT OF PUBLIC SERVICES - Engineering		SCALE	
STANDARD DETAILS - SHEET 4		VERTICAL NOT TO SCALE	
CITY OF KALAMAZOO		HORIZONTAL NOT TO SCALE	
DESIGNED	GHW / JJB	DATE	01/20/2025
DRAWN	GHW / WRE		
QA/QC	JJB		

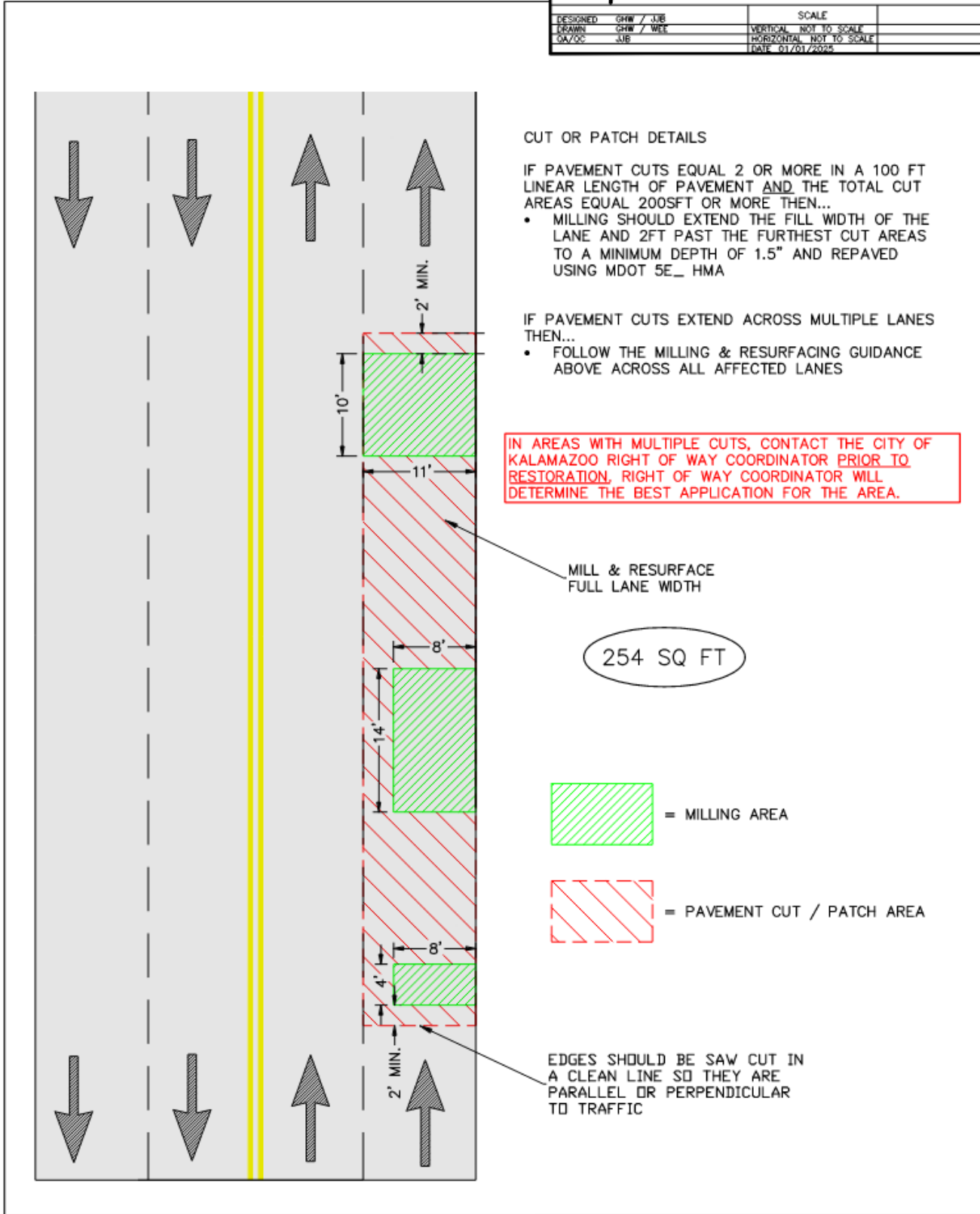
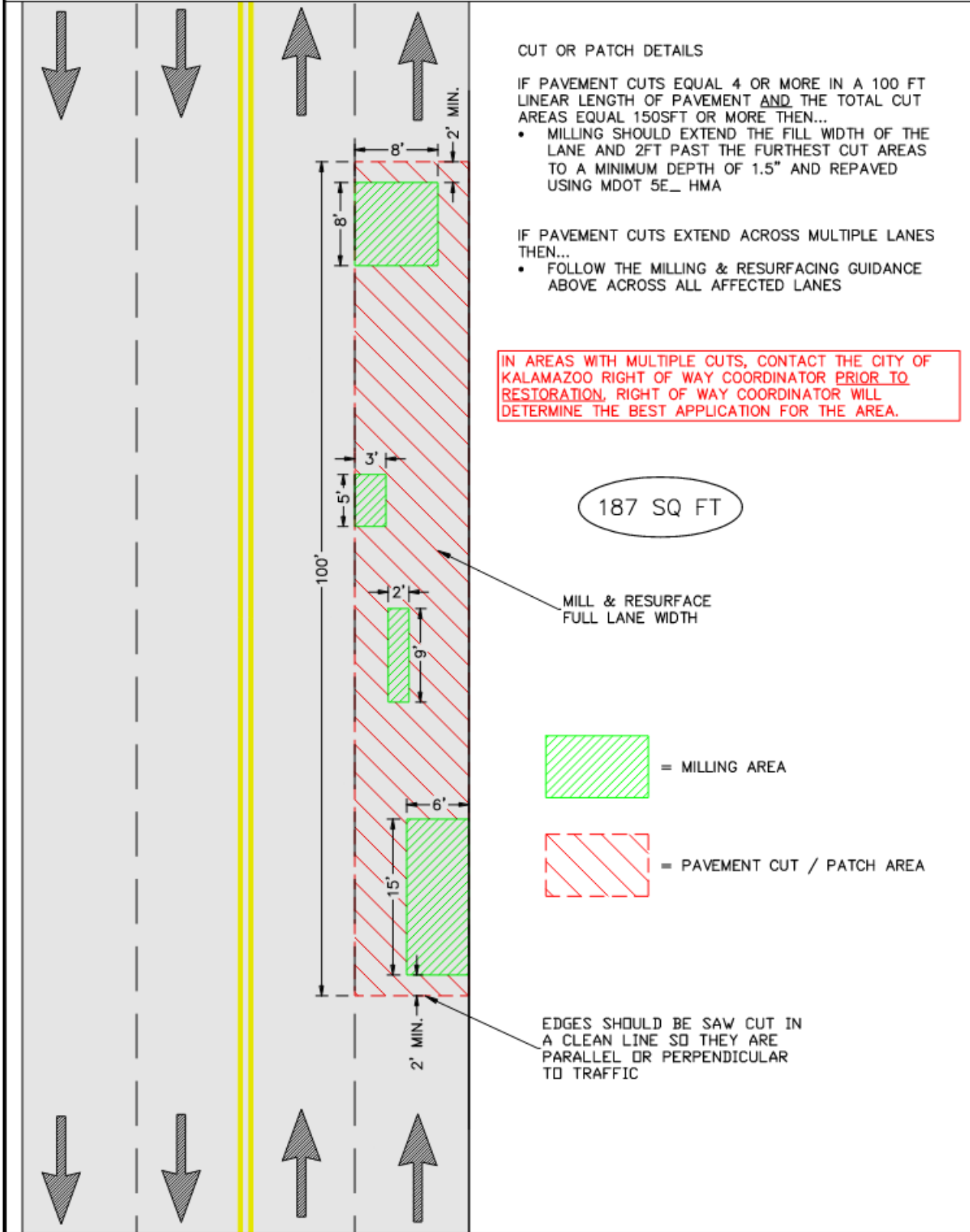

PAVEMENT CUT / PATCHING DETAILS

 DEPARTMENT OF PUBLIC SERVICES - Engineering STANDARD DETAILS - SHEET 5 CITY OF KALAMAZOO	
DESIGNED: GHW / JJB	SCALE:
DRAWN: GHW / WEE	VERTICAL: NOT TO SCALE
CHECKED: JJB	HORIZONTAL: NOT TO SCALE
	DATE: 01/20/2025

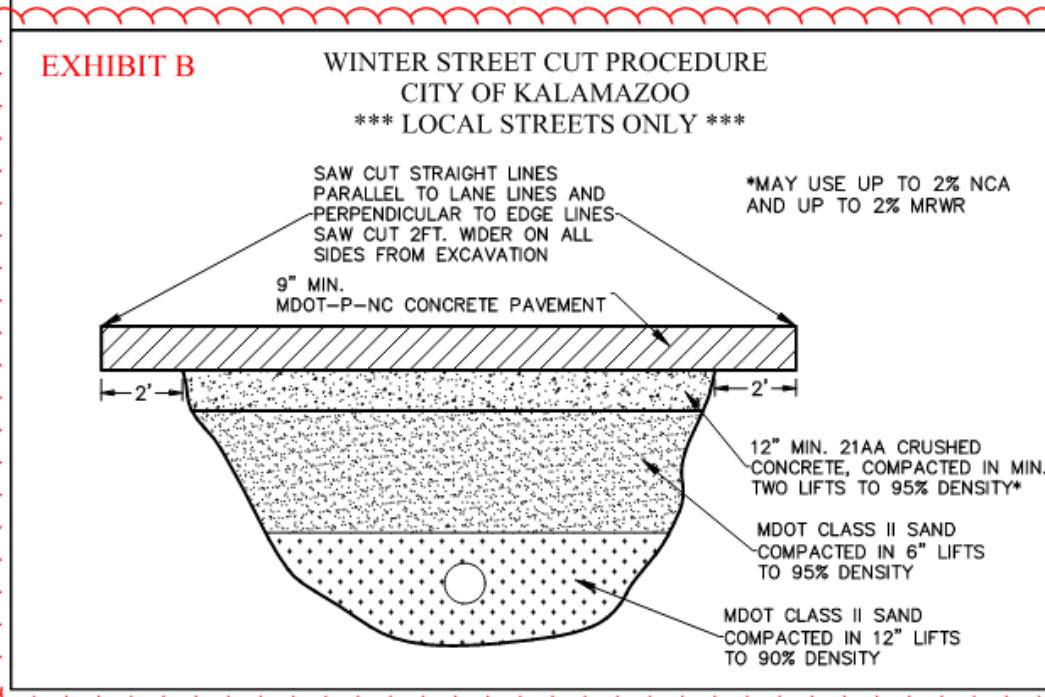
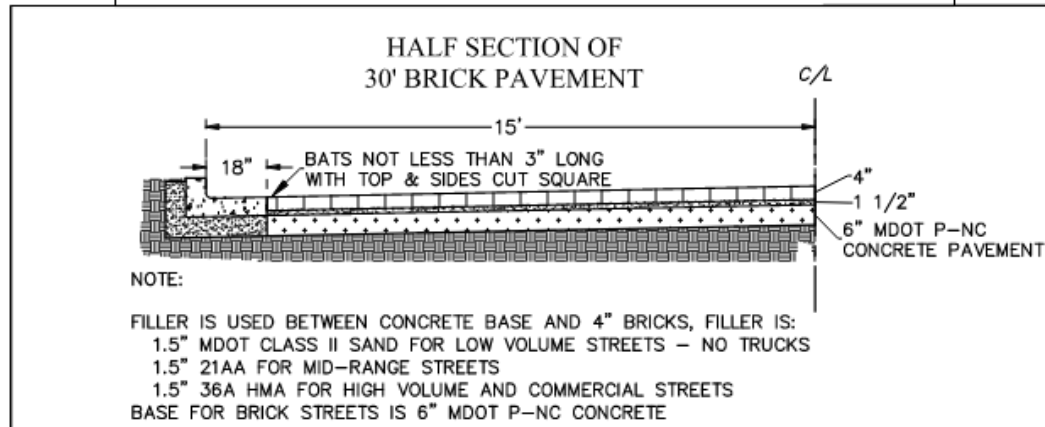
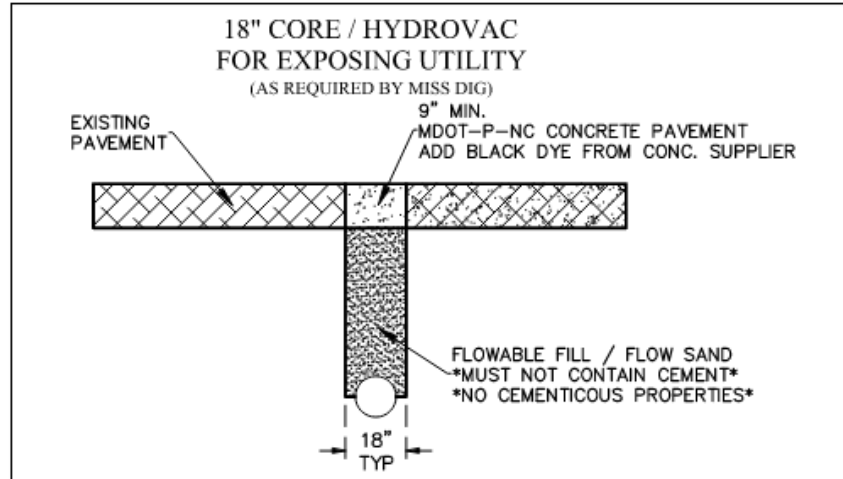

CFS:DMG

3 of 3

20SP-403A-02
03-08-22

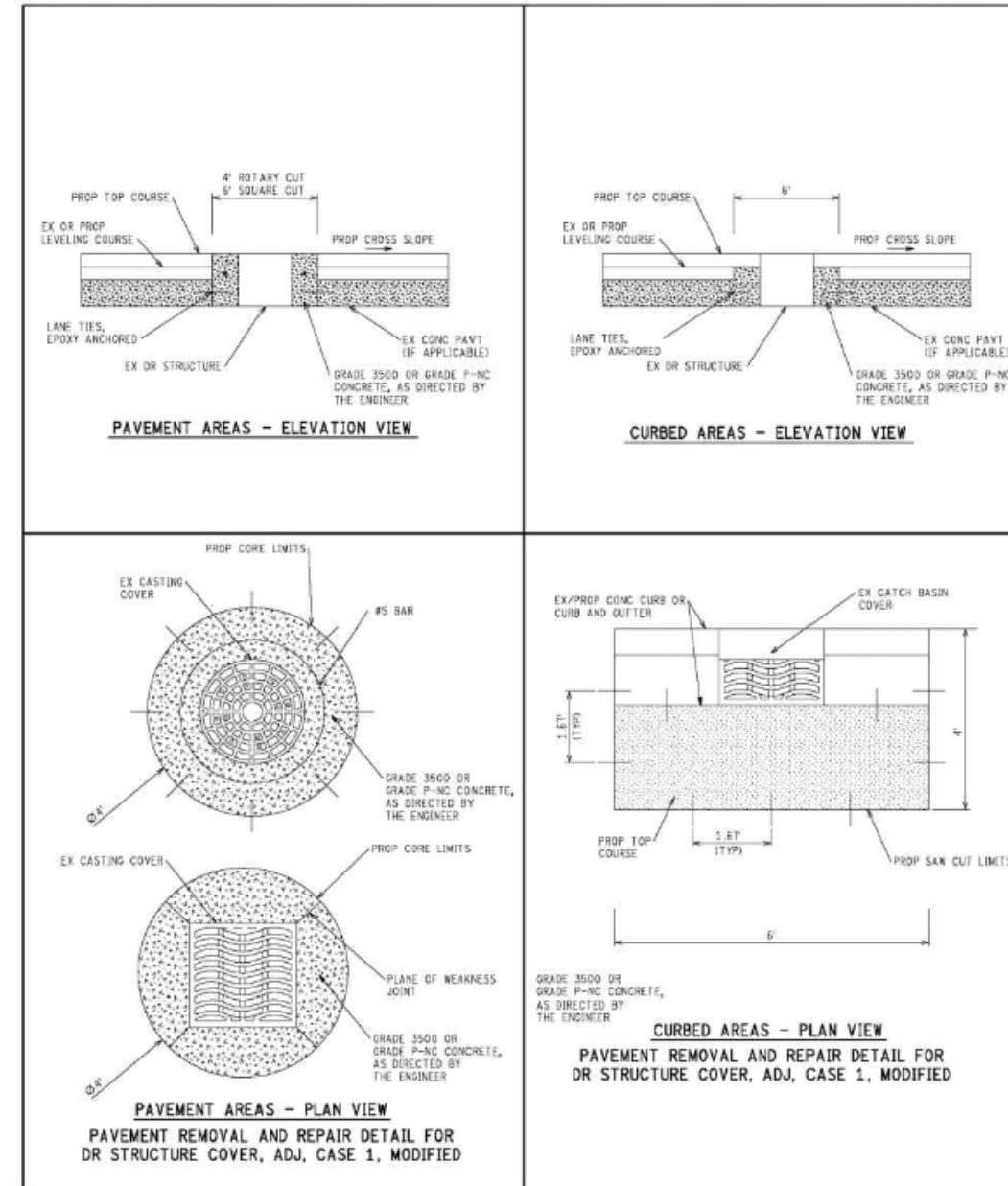

APPROVED
111.10 - MILES OF MAJOR STREET
13.74 - Section 10a(9) Miles
166.00 - MILES OF LOCAL STREET
FOR THE PERIOD
JULY 1, 2023 to JUNE 30, 2024
BY
[Signature]
ACT BY ADMINISTRATOR
July 1, 2023
DATE OF APPROVAL

STATE COPY
I hereby certify that all of the streets shown hereon by symbol as major streets and local streets, are open and in use as public streets and under the jurisdiction of the municipality.

E-SIGNED by James Baker
on 2024-07-15 15:59:35 EDT

Street Administrator Date
By authority of the Governing Body

RECEIVED
By Authority of the Governing Body

No Changes

CITY OF KALAMAZOO
KALAMAZOO COUNTY

POP 73,988 - 2020 CENSUS
725.35 - R-1110, 12W
STREET SYSTEM
THE MICHIGAN HIGHWAY LAW,
PUBLIC ACT 51 OF 1961, AS AMENDED
MICHIGAN DEPARTMENT OF TRANSPORTATION
1 inch equals 1200 feet Map size 36x48



ROAD SYSTEM	LEGEND	GEOGRAPHY
STATE TRUNKLINE	CROSSINGS	SECTIONS
COUNTY PRIMARY	ADJACENT JURISDICTION ROAD	NONFOCUS AREAS
COUNTY LOCAL	STATE PARKROAD	LAKE / RIVER
CITY MAJOR	RAILROAD	HYDROGRAPHY
CITY LOCAL		

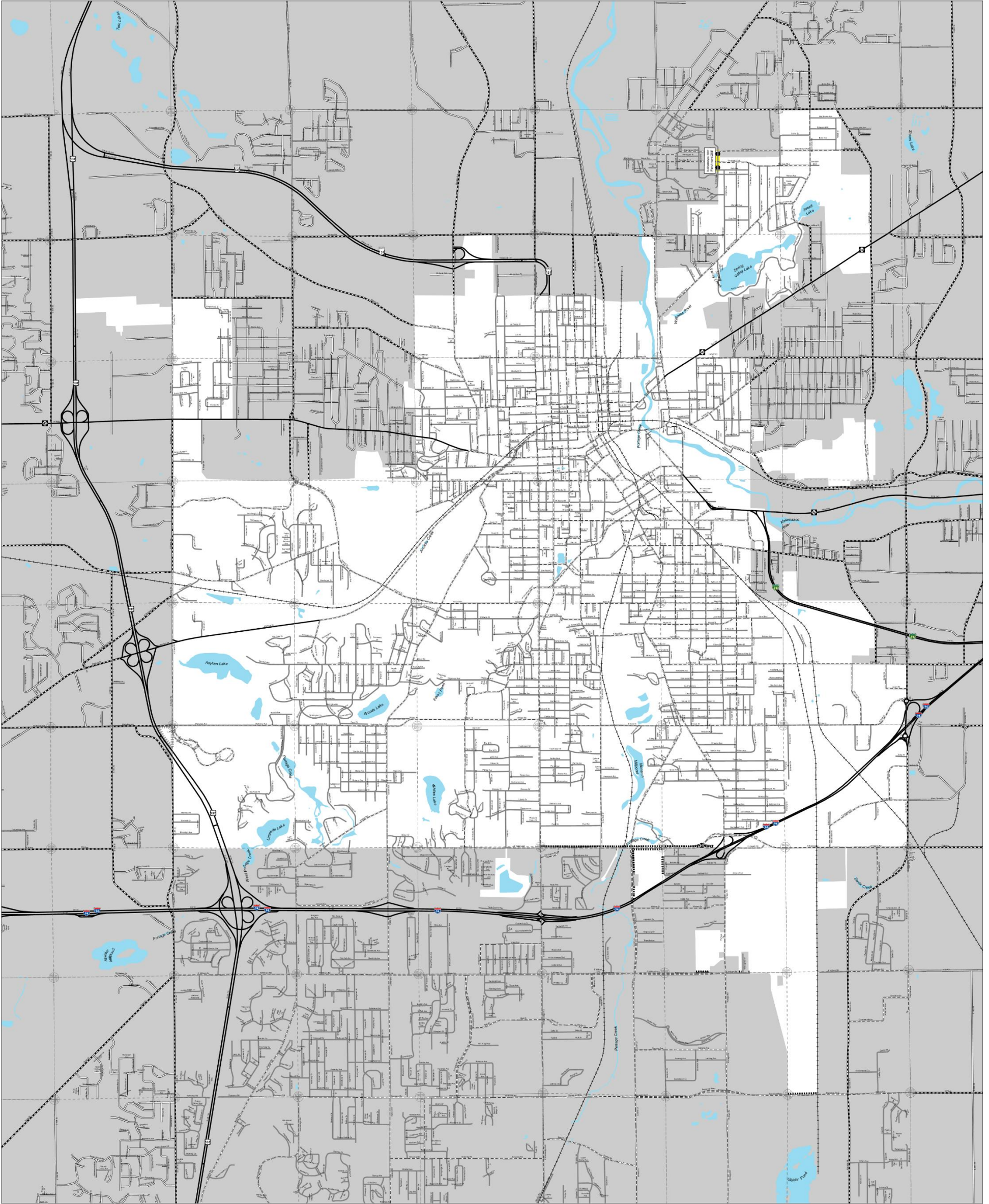

PROJECT OVERVIEW MAP

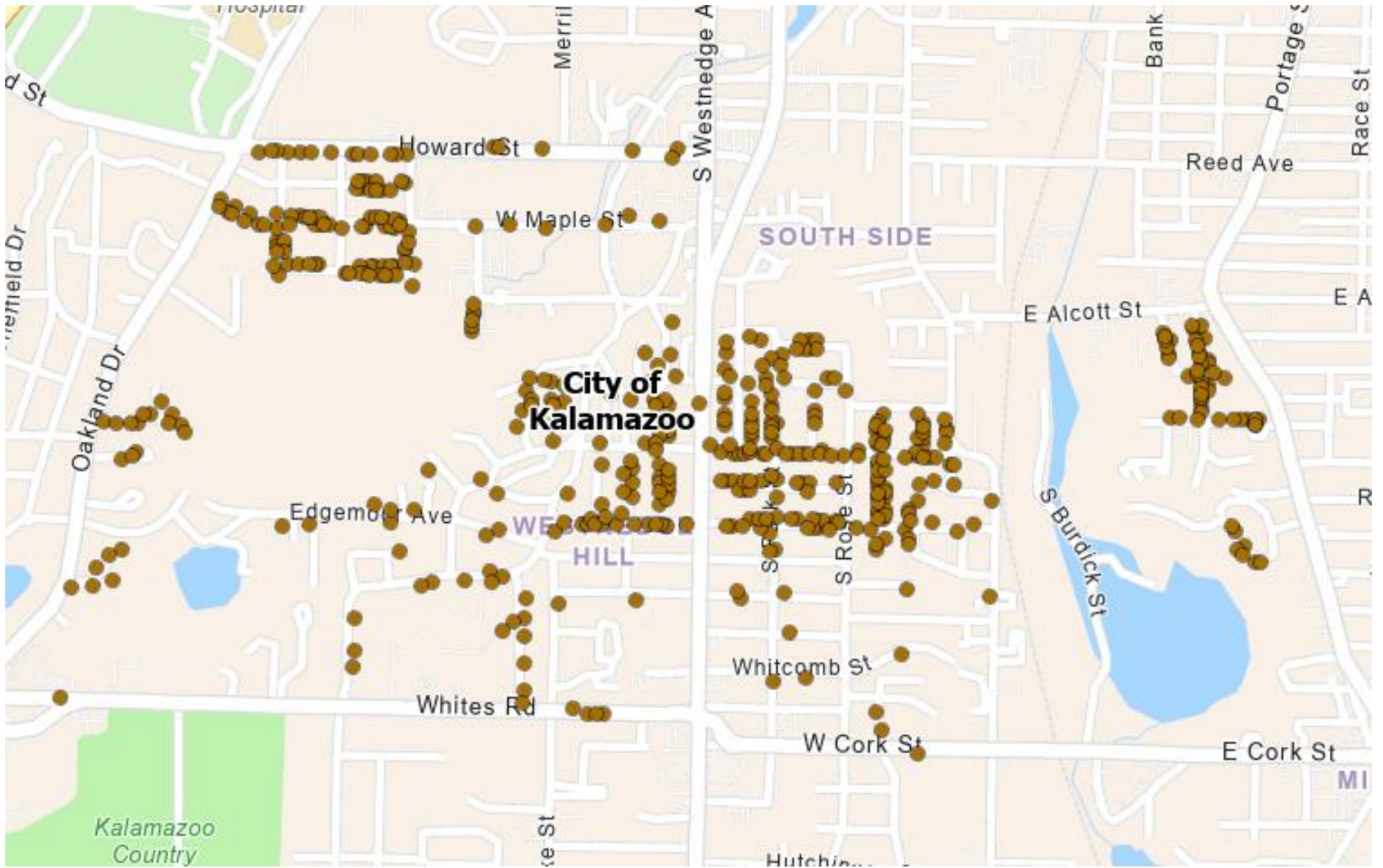

PROJECT ADDRESS LIST

2114 ADELAIDE ST	1119 CHERRY ST	115 CRESCENT DR
2118 ADELAIDE ST	1123 CHERRY ST	126 CRESCENT DR
2120 ADELAIDE ST	1202 CHERRY ST	208 CRESTON AVE
2121 ADELAIDE ST	1207 CHERRY ST	304 CRESTON AVE
2128 ADELAIDE ST	1208 CHERRY ST	305 CRESTON AVE
2134 ADELAIDE ST	1211 CHERRY ST	308 CRESTON AVE
2136 ADELAIDE ST	1213 CHERRY ST	314 CRESTON AVE
2436 ALTA VISTA AVE	1214 CHERRY ST	325 CRESTON AVE
3104 ASH ST	1223 CHERRY ST	410 CRESTON AVE
3117 ASH ST	1227 CHERRY ST	417 CRESTON AVE
1800 BRENTWOOD AVE	1314 CHERRY ST	418 CRESTON AVE
1803 BRENTWOOD AVE	1318 CHERRY ST	421 CRESTON AVE
1914 BRENTWOOD AVE	1322 CHERRY ST	422 CRESTON AVE
1917 BRENTWOOD AVE	1332 CHERRY ST	425 CRESTON AVE
1919 BRENTWOOD AVE	1342 CHERRY ST	430 CRESTON AVE
1920 BRENTWOOD AVE	1401 CHERRY ST	434 CRESTON AVE
1923 BRENTWOOD AVE	1745 CLOVELLY RD	438 CRESTON AVE
1924 BRENTWOOD AVE	1771 CLOVELLY RD	548 W CROSSTOWN PKY
1932 BRENTWOOD AVE	2705 CLOVELLY RD	645 W CROSSTOWN PKY
2304 BRONSON BLVD	2712 CLOVELLY RD	647 W CROSSTOWN PKY
2320 BRONSON BLVD	2715 CLOVELLY RD	1615 DOVER RD
2336 BRONSON BLVD	2718 CLOVELLY RD	1616 DOVER RD
2517 BRONSON BLVD	113 W CORK ST	1621 DOVER RD
2615 BRONSON BLVD	2125 CRANE AVE	1704 DOVER RD
2739 BRONSON BVLD	2128 CRANE AVE	1706 DOVER RD
2740 BRONSON BLVD	2210 CRANE AVE	1715 DOVER RD
2747 BRONSON BLVD	2222 CRANE AVE	1721 DOVER RD
2771 BRONSON BLVD	2308 CRANE AVE	1731 DOVER RD
2815 BRONSON BLVD	2312 CRANE AVE	2801 DUCHESS DR
2825 BRONSON BLVD	2315 CRANE AVE	2823 DUCHESS DR
2891 BRONSON BLVD	2324 CRANE AVE	2830 DUCHESS DR
2921 BRONSON BLVD	2325 CRANE AVE	2836 DUCHESS DR
2933 BRONSON BLVD	2329 CRANE AVE	2901 DUCHESS DR
2308 S BURDICK ST	2330 CRANE AVE	2925 DUCHESS DR
2314 S BURDICK ST	2333 CRANE AVE	3015 DUCHESS DR
2318 S BURDICK ST	2334 CRANE AVE	3025 DUCHESS DR
2326 S BURDICK ST	2339 CRANE AVE	20 EDGEMOOR AVE
2506 S BURDICK ST	2343 CRANE AVE	112 EDGEMOOR AVE
2710 S BURDICK ST	2347 CRANE AVE	129 EDGEMOOR AVE
1102 CHERRY ST	2348 CRANE AVE	132 EDGEMOOR AVE
1109 CHERRY ST	36 CRESCENT DR	144 EDGEMOOR AVE
1112 CHERRY ST	2512 CRESCENT DR	160 EDGEMOOR AVE
1114 CHERRY ST	2518 CRESCENT DR	161 EDGEMOOR AVE
1115 CHERRY ST	2608 CRESCENT DR	173 EDGEMOOR AVE
1118 CHERRY ST	2616 CRESCENT DR	208 EDGEMOOR AVE
	110 CRESCENT DR	211 EDGEMOOR AVE

216 EDGEMOOR AVE	615 FAIRVIEW AVE	1216 HILLCREST AVE
221 EDGEMOOR AVE	753 FAIRVIEW AVE	1217 HILLCREST AVE
222 EDGEMOOR AVE	803 FOREST GLEN BLVD	1218 HILLCREST AVE
226 EDGEMOOR AVE	318 GARLAND AVE	2311 HILLSIDE PL
227 EDGEMOOR AVE	2109 GLENWOOD DR	2313 HILLSIDE PL
301 EDGEMOOR AVE	2211 GLENWOOD DR	2317 HILLSIDE PL
312 EDGEMOOR AVE	2212 GLENWOOD DR	2321 HILLSIDE PL
316 EDGEMOOR AVE	2222 GLENWOOD DR	2322 HILLSIDE PL
405 EDGEMOOR AVE	2230 GLENWOOD DR	522 HOWARD ST
410 EDGEMOOR AVE	2311 GLENWOOD DR	525 HOWARD ST
411 EDGEMOOR AVE	2318 GLENWOOD DR	816 HOWARD ST
420 EDGEMOOR AVE	2319 GLENWOOD DR	918 HOWARD ST
423 EDGEMOOR AVE	2322 GLENWOOD DR	922 HOWARD ST
431 EDGEMOOR AVE	2330 GLENWOOD DR	1103 HOWARD ST
435 EDGEMOOR AVE	2337 GLENWOOD DR	1111 HOWARD ST
513 EDGEMOOR AVE	2338 GLENWOOD DR	1115 HOWARD ST
525 EDGEMOOR AVE	2341 GLENWOOD DR	1207 HOWARD ST
601 EDGEMOOR AVE	2342 GLENWOOD DR	1221 HOWARD ST
603 EDGEMOOR AVE	2346 GLENWOOD DR	1225 HOWARD ST
613 EDGEMOOR AVE	2412 GLENWOOD DR	1305 HOWARD ST
619 EDGEMOOR AVE	2417 GLENWOOD DR	1321 HOWARD ST
705 EDGEMOOR AVE	2421 GLENWOOD DR	1329 HOWARD ST
714 EDGEMOOR AVE	2424 GLENWOOD DR	1405 HOWARD ST
715 EDGEMOOR AVE	2427 GLENWOOD DR	1415 HOWARD ST
723 EDGEMOOR AVE	2430 GLENWOOD DR	2002 HUDSON ST
728 EDGEMOOR AVE	2503 GLENWOOD DR	2004 HUDSON ST
729 EDGEMOOR AVE	2504 GLENWOOD DR	2006 HUDSON ST
731 EDGEMOOR AVE	2511 GLENWOOD DR	2008 HUDSON ST
739 EDGEMOOR AVE	2514 GLENWOOD DR	2010 HUDSON ST
902 EDGEMOOR AVE	223 GRANDVIEW AVE	2012 HUDSON ST
905 EDGEMOOR AVE	226 GRANDVIEW AVE	33 INKSTER AVE
1030 EDGEMOOR AVE	301 GRANDVIEW AVE	101 INKSTER AVE
1033 EDGEMOOR AVE	305 GRANDVIEW AVE	107 INKSTER AVE
1113 EDGEMOOR AVE	306 GRANDVIEW AVE	115 INKSTER AVE
1114 EDGEMOOR AVE	310 GRANDVIEW AVE	118 INKSTER AVE
1122 EDGEMOOR AVE	311 GRANDVIEW AVE	121 INKSTER AVE
1335 EDGEMOOR AVE	325 GRANDVIEW AVE	125 INKSTER AVE
1339 EDGEMOOR AVE	1102 HILLCREST AVE	126 INKSTER AVE
1708 EMBURY RD	1106 HILLCREST AVE	133 INKSTER AVE
1710 EMBURY RD	1115 HILLCREST AVE	161 INKSTER AVE
1737 EMBURY RD	1121 HILLCREST AVE	162 INKSTER AVE
1739 EMBURY RD	1201 HILLCREST AVE	175 INKSTER AVE
127 FAIRVIEW AVE	1202 HILLCREST AVE	201 INKSTER AVE
322 FAIRVIEW AVE	1205 HILLCREST AVE	211 INKSTER AVE
430 FAIRVIEW AVE	1210 HILLCREST AVE	218 INKSTER AVE
431 FAIRVIEW AVE	1213 HILLCREST AVE	219 INKSTER AVE

229 INKSTER AVE	924 W MAPLE ST	714 NORTON DR
307 INKSTER AVE	1005 W MAPLE ST	720 NORTON DR
311 INKSTER AVE	1103 W MAPLE ST	1841 OAKLAND DR
315 INKSTER AVE	1107 W MAPLE ST	2331 OAKLAND DR
321 INKSTER AVE	1108 W MAPLE ST	2313 OSTRANDER ST
407 INKSTER AVE	1109 W MAPLE ST	2319 OSTRANDER ST
415 INKSTER AVE	1110 W MAPLE ST	2310 OUTLOOK ST
419 INKSTER AVE	1115 W MAPLE ST	2314 OUTLOOK ST
425 INKSTER AVE	1117 W MAPLE ST	2317 OUTLOOK ST
431 INKSTER AVE	1118 W MAPLE ST	2318 OUTLOOK ST
439 INKSTER AVE	1120 W MAPLE ST	2323 OUTLOOK ST
448 INKSTER AVE	1208 W MAPLE ST	2327 OUTLOOK ST
605 INKSTER AVE	1210 W MAPLE ST	2328 OUTLOOK ST
614 INKSTER AVE	1215 W MAPLE ST	2331 OUTLOOK ST
715 INKSTER AVE	1219 W MAPLE ST	2403 OUTLOOK ST
2606 KALANCO ST	1229 W MAPLE ST	2408 OUTLOOK ST
2513 LAW AVE	1305 W MAPLE ST	2411 OUTLOOK ST
2303 LINWOOD DR	1309 W MAPLE ST	2412 OUTLOOK ST
614 LUELLA CT	1315 W MAPLE ST	2416 OUTLOOK ST
2112 LUELLA ST	1316 W MAPLE ST	2420 OUTLOOK ST
2113 LUELLA ST	1319 W MAPLE ST	2425 OUTLOOK ST
2114 LUELLA ST	1320 W MAPLE ST	2426 OUTLOOK ST
2121 LUELLA ST	1324 W MAPLE ST	2430 OUTLOOK ST
2124 LUELLA ST	1328 W MAPLE ST	2431 OUTLOOK ST
2128 LUELLA ST	1330 W MAPLE ST	2503 OUTLOOK ST
2132 LUELLA ST	1339 W MAPLE ST	2504 OUTLOOK ST
2136 LUELLA ST	1340 W MAPLE ST	2508 OUTLOOK ST
2141 LUELLA ST	1401 W MAPLE ST	2512 OUTLOOK ST
2144 LUELLA ST	1402 W MAPLE ST	2513 OUTLOOK ST
2145 LUELLA ST	1411 W MAPLE ST	2517 OUTLOOK ST
2148 LUELLA ST	1415 W MAPLE ST	2518 OUTLOOK ST
2149 LUELLA ST	1427 W MAPLE ST	2607 OUTLOOK ST
2204 LUELLA ST	1428 W MAPLE ST	2616 OUTLOOK ST
2208 LUELLA ST	1439 W MAPLE ST	2620 OUTLOOK ST
2209 LUELLA ST	1440 W MAPLE ST	518 S PARK ST
2210 LUELLA ST	1443 W MAPLE ST	2130 S PARK ST
2213 LUELLA ST	1451 W MAPLE ST	2212 S PARK ST
2214 LUELLA ST	2336 MIDVALE TER	2215 S PARK ST
2216 LUELLA ST	125 MILLVIEW AVE	2216 S PARK ST
2218 LUELLA ST	149 MILLVIEW AVE	2308 S PARK ST
2222 LUELLA ST	402 MONTROSE AVE	2316 S PARK ST
2228 LUELLA ST	605 NORTON DR	2320 S PARK ST
2232 LUELLA ST	609 NORTON DR	2330 S PARK ST
2236 LUELLA ST	620 NORTON DR	2334 S PARK ST
590 W MAPLE ST	701 NORTON DR	2340 S PARK ST
807 W MAPLE ST	706 NORTON DR	2342 S PARK ST

2343 S PARK ST
2345 S PARK ST
2404 S PARK ST
2424 S PARK ST
2425 S PARK ST
2519 S PARK ST
2522 S PARK ST
2621 S PARK ST
205 PARKWOOD DR
210 PARKWOOD DR
217 PARKWOOD DR
220 PARKWOOD DR
324 PARKWOOD DR
404 PARKWOOD DR
405 PARKWOOD DR
421 PARKWOOD DR
438 PARKWOOD DR
513 PHILLIPS ST
519 PHILLIPS ST
609 PHILLIPS ST
621 PHILLIPS ST
627 PHILLIPS ST
633 PHILLIPS ST
637 PHILLIPS ST
641 PHILLIPS ST
2315 PLYMOUTH LN
2346 PLYMOUTH LN
2320 RIDGE RD
2347 S ROSE ST
2520 S ROSE ST
2238 SPRINGHILL DR
2239 SPRINGHILL DR
2304 SPRINGHILL DR
2317 SPRINGHILL DR
2321 SPRINGHILL DR
2326 SPRINGHILL DR
2340 SPRINGHILL DR
1914 STEARNS AVE
1918 STEARNS AVE
1922 STEARNS AVE
1933 STEARNS AVE
2007 STEARNS AVE
2321 TREMONT ST
2325 TREMONT ST
2329 TREMONT ST
2405 UNIVERSITY AVE
2413 UNIVERSITY AVE
2422 UNIVERSITY AVE
2425 UNIVERSITY AVE
2436 UNIVERSITY AVE
2507 UNIVERSITY AVE
2524 UNIVERSITY AVE
2314 WESTCHESTER LN
2322 WESTCHESTER LN
2336 WESTCHESTER LN
2350 WESTCHESTER LN
2316 S WESTNEDGE AVE
129 WHITCOMB ST
305 WHITCOMB ST
325 WHITCOMB ST
719 WHITES RD
723 WHITES RD
733 WHITES RD
746 WHITES RD
1900 WHITES RD
913 WILSHIRE BLVD PL
1033 WILSHIRE BLVD PL
528 WITWER CT

**CITY OF KALAMAZOO
DEPARTMENT OF
PUBLIC SERVICES**

WATER RESOURCES DIVISION



PUBLIC SERVICES DEPARTMENT

WATER RESOURCES DIVISION
415 STOCKBRIDGE AVE.
KALAMAZOO, MICHIGAN 49001-2898
PHONE 269-337-8601
FAX 269-337-8533

**Standard Specifications for
Water Main and Service Installation
2021**



WATER MAIN AND WATER SERVICES

PART 1 GENERAL

1.01 SCOPE

- A. This Section includes furnishing and installing water main systems.
- B. Reconnection of proposed water main and/or water service connections to existing water main and/or water service constructions shall be in conformance with requirements of this Section.
- C. This Section shall include furnishing, excavating, installing, testing, disinfecting, and backfilling all required water main pipe, water service pipes, water main appurtenances, water service, and other work incidental to the water main and/or water service installation unless specifically included under other Items.
- D. This work shall also consist of providing as-constructed plans of the completed work.

1.02 SUBMITTALS

- A. Submittals shall be the responsibility of the Contractor:
 - 1. Shop Drawings for Review:
 - a. Manufacturer's Shop Drawings indicating physical dimensions, and joint details for each size, type, and class of pipe, fittings and specials furnished for the project.
 - 2. Information for the Record:
 - a. Manufacturer's certification indicating that the pipe and joints meet specifications for each production run for each size, type, and class of pipe furnished. The Engineer may request test results to verify certification. Certification documents shall be according to the Source Quality Control of this Section.
 - b. Manufacturer's installation instructions.
 - c. The laboratory shall submit test certifications of pipe ordered tested under "Field Quality Control," of this Section.
 - 3. Engineer may request additional Shop Drawings or Information for the Record as required.
 - 4. **Requests for approved equals must be submitted to the Engineer for review a minimum of two (2) weeks prior to bid.**

1.03 AS CONSTRUCTED RECORD

- A. During construction the contractor shall be required to keep current a set of "as constructed" drawings. Before final payment shall be made, the contractor shall submit for approval to the City of Kalamazoo the complete set of as constructed drawings. Each set of "as constructed" drawings shall be labeled "As Constructed", dated, and contain at a minimum the following information (additional information may be required by the City of Kalamazoo):
 - 1. Note distance between all fittings (Center to Center of Fittings).
 - 2. Note Hydrant to valve, valve to main distances (Center to Center of Fittings).
 - 3. Note the type of bend used, (# of degrees), and the Direction of Bend: (Up or down), (N-S-E-W).

4. Note lengths and locations of restrained joints.
5. Details and profiles of special field situations that relate to the water distribution system shall be included.
6. Dimensional information locating each water distribution system component to real world features, such as property lines, right-of-way lines, and centerlines of roads.
7. On all cul-de-sacs with no center island, measure bends and hydrants to center of cul-de-sac. On all cul-de-sacs with a center island, measure bends and hydrants to center of the roadway.
8. When fittings/hydrants are installed as proposed, please circle the proposed listing.
9. All hydrants shall be noted as to whether or not drip valve plugs were installed.
10. When installing 12 inch or larger valves, (Butterfly Valves), indicate which side of the main the operating nut was placed, as well as gear box style with number of turns to close.
11. The contractor shall complete the service card information including a sketch of the water service installation with dimensions and location of the curb box.
12. Contractor shall GPS all valves, hydrants, fittings, as well a minimum every 3 lengths of pipe for straight runs. DWG files shall be provided to the Engineer upon completion of the project. GPS accuracy shall be subfoot.
13. **All as-built record drawings shall be completed and turned in to the Engineer within 2 weeks from completion of the installation.**

1.04 CONTRACT WORK

- A. Prior to the start of construction, the City of Kalamazoo shall be given the opportunity to provide construction services for any and all portions of the water main construction. The City of Kalamazoo shall submit an estimated cost to perform the work or will issue a bill based on time and material costs. A separate contract with the City of Kalamazoo will be needed for work to be performed by the City of Kalamazoo.
 1. City of Kalamazoo shall perform all water main taps in the water system, unless otherwise directed by the Engineer.
- B. The City of Kalamazoo Department of Public Services must approve the Contractor who will perform water main installation. A reference list of at least five (5) Type 1 supply water main projects completed by the Contractor shall be submitted in support of the Contractor's qualifications. The Department of Public Services maintains a list of Contractors approved for water main installation and can be contacted to receive a current copy of that list.
- C. The Contractor (when hired by the City) or Developer (when the Contractor is hired to perform work by the Developer), shall provide a written statement of warranty (Warranty Bond) for a period of 2 years from the date of **final acceptance** for water main work or **after meter is installed** for water service work. Warranty work shall cover any necessary cost to repair water main or appurtenance leaks and water main or appurtenance leak damage at no cost to the City of Kalamazoo. Final acceptance on all water main and appurtenance work shall not occur until all items have been inspected by the Engineer, passed all required testing, as well as receipt and approval of all as built documents. Additionally, final acceptance on a water service will only be given **once the water meter is installed**.
 1. Water service or water main warranty work shall be completed either a prequalified contractor under the inspection of the City of Kalamazoo, or by City of Kalamazoo field service crews. All warranty work shall be paid for by the Developer or the Contractor.
- D. The Contractor is responsible for field locating all work which has not yet received final acceptance by the City of Kalamazoo. All damage to work that has not received final acceptance is the responsibility of the Contractor.

PART 2 PRODUCTS

All Products shall be supplied new from the manufacturer and certified new from the supplier. No second hand or salvaged material shall be allowed. All products shall be **“Buy American”** unless otherwise specified in this section.

2.01 DUCTILE IRON

A. Ductile Iron (DI) Pipe Specifications:

1. Ductile Iron Pipe shall be manufactured in accordance with American National Standards Institute (ANSI) and American Water Works Association (AWWA) ANSI/AWWA C150/A21.50 and C151/A21.51. Pipe shall be minimum thickness Class 52 pipe. Flanged pipe shall be manufactured in accordance with ANSI/AWWA C 115/A21.15. Pipe through concrete floors or foundations shall be minimum thickness Class 53 pipe.
 - a. Water pipe must be lined with a standard thickness cement mortar lining sealed with a bituminous seal coat in accordance with ANSI/AWWA C104/A21.4, unless otherwise required. The outside of the pipe must be coated with the standard bituminous seal and each length of pipe must be marked with the following information
 - 1) Metal thickness class.
 - 2) Net weight of the pipe without lining.
 - 3) The nominal size.
 - 4) The manufacturer's identifying symbol.
 - b. Underground pipe shall be push on or mechanical joints and above ground pipe shall be flanged joints with gaskets meeting the requirements of ANSI/AWWA C111/A21.11. Nitrile or fluoroelastomer gaskets shall must be used as indicated on the plans and in locations of known or suspected soil or groundwater contamination as necessary. Gaskets provided will be specified based on the type of contamination that is encountered. Each joint shall contain serrated silicon bronze electrical continuity wedges as directed by the Engineer or authorized representative. 4 to 6 inch pipe shall use 2 wedges, 8 to 12 inch pipe shall use 3 wedges, and 16 inch and above shall use 4 wedges.
 - c. Pipe used in conjunction with Horizontal Directional Drilling operations shall be Flex-Ring or TR FLEX joints.

B. Restrained Joints

1. Restrained joints shall meet the requirements of ANSI/AWWA C111/A21.11, and AWWA/ANSI C110/A21.10 or ANSI/AWWA C153/A21.53.
2. Mechanical restrained joints shall be EBAA Iron Megalug series 1100, Romac Romagrip, Ford Series 1400, or approved equal.
 - a. Restraint devices for nominal pipe sizes 4 inch through 54 inch shall consist of multiple gripping wedges incorporated into a follower gland meeting the applicable requirements of ANSI/AWWA C110/A21.10.
 - b. The devices shall have a working pressure rating of 350 psi for 4 to 16 inch, 250 psi for 18 to 48 inch and 200 psi for the 54 inch size. Ratings are for water pressure and must include a minimum safety factor of 2 to 1 in all sizes.

- c. Gland body, wedges and wedge actuating components shall be cast from grade 65-45-12 ductile iron material in accordance with ASTM A536.
 - d. Ductile iron gripping wedges shall be heat treated within a range of 370 to 470 BHN.
 - e. Three (3) test bars shall be incrementally poured per production shift as per Underwriter's Laboratory (U.L.) specifications and ASTM A536. Testing for tensile, yield and elongation shall be done in accordance with ASTM E8.
 - f. Chemical and nodularity tests shall be performed as recommended by the Ductile Iron Society, on a per ladle basis.
 - g. All components shall be manufacture and assembled in the United States.
 - h. Coating for restraint devices shall consist of the following:
 - 1) All wedge assemblies and related parts shall be processed through a phosphate wash, rinse and drying operation prior to coating application. The coating shall consist of a minimum of two coats of liquid thermoset epoxy coating with heat cure to follow each coat.
 - 2) All casting bodies shall be surface pretreated with a phosphate wash, rinse and sealer before drying. The coating shall be electrostatically applied and heat cured. The coating shall be a polyester based powder to provide corrosion, impact and UV resistance.
 - 3) The coating system shall be MEGA-BOND by EBAA Iron, Inc. or approved equal.
3. Push on restrained joint shall be field locking gasket or Flex Ring style as manufactured by US Pipe, McWane, American USA, or approved equal. Field locking or Flex Ring gasket shall match appropriately to the manufacturer of the pipe used.
 4. Use of threaded rods or thrust blocks as a restrained joint shall not be permitted, unless approved by the Engineer.
 5. Restrained flange adapters shall be EBAA Iron Megaflange series 2100 or approved equal.
 - a. Restrained flange adapters shall be made of ductile iron conforming to ASTM A536 and have flange bolt circles that are compatible with ANSI/AWWA C110/A21.10 (125#/Class 150 Bolt Pattern).
 - b. Restraint for flange adapter shall consist of plurality of individual actuated gripping wedges to maximize restraint capability. Torque limiting actuating screws shall be used to insure proper initial set of gripping wedges.
 - c. The flange adapters shall be capable of deflection during assembly or permit lengths of pipe to be field cut to allow a minimum of 0.6 inch gap between the end of the pipe and the mating flange without affecting the integrity of the seal.
 - d. All internal surfaces of the gasket ring (wetted parts) shall be lined with a minimum of 15 mils of fusion bonded epoxy conforming to the applicable requirements of ANSI/AWWA C213. The coating shall meet ANSI/NSF-61. Exterior surfaces of the gasket ring shall be coated with a minimum of 6 mils of fusion bonded epoxy conforming to the applicable requirements of ANSI/AWWA C116/A21.16.
 - e. Restraint Ring coated with MEGA-Bond Restraint Coating System.

C. Ductile Iron Pipe Fittings

1. Fittings, plugs, and gaskets must meet the requirements of ANSI/AWWA C111/A21.11, and AWWA/ANSI C110/A21.10 or ANSI/AWWA C153/A21.53. Cement mortar linings for fittings must meet the requirements of ANSI/AWWA C104/A21.4.
2. Mechanical joints shall be EBAA Iron Megalug series 1100, Romac Romagrip, or approved equal.
3. Restrained flange adapters shall be EBAA Iron Megaflange series 2100 or approved equal.

2.02 Ductile Iron Valves

- A. All underground valves in sizes from 4 inches to 10 inches shall be reduced wall, resilient-seated gate valves for water supply service meeting the requirements of AWWA C 515. Valves shall be American Flow Control Series 2500, Clow model 2638, or EJ Flowmaster Series resilient seated gate valve, Mechanical joint with rubber gaskets (per AWWA/ANSI C 111/A21.11), ductile iron body, stainless steel stem, mechanical joint restraint, and ¾ inch tee head bolts. Valves shall open right (clockwise) and be equipped with standard AWWA operating nut. Nut shall be color coded red. Valves shall have a working pressure rating of 250 psi or greater.
1. In lieu of a mechanical joint restraint, American Flow Control Series 2500 valves may be equipped with ALPHA joints.
- B. All underground valves 12 inches and larger shall be rubber-seated butterfly valves meeting the requirements of AWWA C 504. Valves shall be Pratt Groundhog Butterfly Valves, by Henry Pratt Company, Clow, M&H, or Kennedy model 4500, mechanical joint with rubber gaskets (per AWWA/ANSI C 111/A21.11), ductile iron body, mechanical joint restraint, and ¾ inch tee head bolts. Valves shall open right (clockwise) and be equipped with standard AWWA operating nut. Nut shall be color coded red. Valves shall have a working pressure rating of 250 psi or greater.
- C. All above ground or in pits/vaults valves between 3 inches and 10 inches shall be rubber seated gate valves meeting the requirements of AWWA C515. Valves shall be American Flow Control Series 2500 Resilient Wedge Gate Valve, Clow model 2638, EJ Flowmaster Series, or approved equal with flanged joint with rubber gaskets (per AWWA/ANSI C 111/A21.11), ductile iron body, stainless steel bolts, nuts and washers, stainless steel stem, and be equipped with a hand wheel to operate. Valves shall have a working pressure rating of 150 psi or greater.
- D. All above ground or in pits/vaults valves 12 inches and larger shall be rubber seated butterfly valves meeting the requirements of AWWA C504. Valves shall be by Henry Pratt Company, Clow, M&H, or Kennedy, flanged joint with rubber gaskets (per AWWA/ANSI C 111/A21.11), ductile iron body, and ¾ inch stainless steel bolts, washers and nuts. Valves shall open right (clockwise) and be equipped with standard wheel to operate. Valves shall have a working pressure rating of 150 psi or greater.
- E. All underground valves in sizes from 4 inches to 16 inches used in combination with a tapping saddle shall be reduced wall, resilient-seated gate valves for water supply service meeting the requirements of AWWA C 515. Valves shall be American Flow Control Series 2500, Clow model 2638, EJ Flowmaster Series with one flanged and one mechanical joint ends with rubber gaskets (per AWWA/ANSI C 111/A21.11), ductile iron body, stainless steel stem, mechanical joint restraint, and ¾ inch tee head bolts or approved equal. Valves shall open right (clockwise) and be equipped with standard AWWA operating nut. Nut shall be color coded red. Valves shall have a working pressure rating of 250 psi or greater.

- F. All valves used in conjunction with a fire service line shall be Mueller R-2361-6 Outside Screw and Yoke (O.S.&Y.) with sample tap or approved equal. The stem shall be type 304 stainless steel. Sample tap shall have a 4 ½ inch brass nipple, brass ball valve, and brass plug meeting NSF/ANSI Standard 61 requirements. Sample tap shall be ½ inch for 4 inch and smaller valves and ¾ inch for valves larger than 4 inch.
- G. All valves installed using the insertion style method shall be an all stainless steel body Resilient Wedge Gate Valve designed for permanent use in potable water systems. The design will allow the valve to be installed into an existing pressurized pipeline while maintaining constant pressure and service without system shutdown. No restraining devices, restraining fasteners, or transition gaskets shall be required for the installation or operation of the valve. Valves in sizes 4 inches to 12 inches shall be Hydra-Stop Insta-Valve 250 or approved equal. 16 inch valves shall be Hydra-stop Insta-Valve Plus 250 or approved equal.

2.03 HYDRANTS

- A. All fire hydrants shall be American Flow Control or EJ and shall meet the requirements of AWWA C502. Hydrants shall be provided as complete units including hydrant, hydrant marker, pipe, pipe fittings and valve meeting section 2.01, 2.03 and 2.04 requirements. Hydrants shall be supplied for a bury depth of 5.5 feet. The hydrant barrel shall be painted safety yellow by the manufacturer. Hydrant caps and operating nut shall be painted John Deere green by the manufacturer.
 - 1. American Flow Control hydrants shall be 5 ¼ inch Waterous Pacer Traffic Model WB67-250. Hydrants shall be supplied with a 16 inch upper standpipe length. The Hydrant will come equipped with a bronze upper valve washer. In lieu of a mechanical joint restraint, hydrants may be equipped with ALPHA joints.
 - 2. EJ hydrants shall be WaterMaster Model 5BR250 with snow barrel.
- B. Hydrants shall come equipped with a Carrol Drain. Drain piping shall be made of type 304 stainless steel. External port shall have removable cap for flushing hydrant. Carrol Drain assembly shall be constructed so that it is removable when replacement of assembly is necessary.
- C. Hydrants shall have two 2 ½ inch national standard hose connections, 7.5 threads per inch, OD of threads 3 1/16 inch and one 5 inch integral "STORZ" type nozzle connection. Hose nozzle cap nut, weather shield hydrant operating nut, Storz nozzle cap nut, and Carrol Drain cap nut shall be square 15/16 inch at bottom of nut tapered to 13/16 inch at top (Waterous reference #19). The hydrant mechanism shall be on a non-rising stem opening clockwise. Chains shall not be supplied with the hydrant caps.
- D. Hydrants shall be equipped drip valve, tapped for plug. The drip valve system shall be bronze. Draining system shall be positively activated by the main operating rod, meaning the drip valve will open when the hydrant is closed. Hydrant shall be provided with plug removed.
- E. Hydrants shall have a 6 inch shoe with mechanical joint connections in conformance to ANSI/AWWA C115/21.11.

2.04 FIRE HYDRANT MARKER

- A. The fire hydrant sign shall be installed on a galvanized 2 pound sign post.
- B. The fire hydrant sign shall be aluminum 8 inch x 18 inch (MDOT type III-A) with hydrant symbol and down arrow of a reflective material.
- C. Fire hydrant mounted marker whips shall be 4 feet x 3/8 inch solid pultrusion fiberglass shaft, with seven (7) 6 inch bands of E.G. reflective sheeting of alternating lime green and red color.

Marker shall have a single solid stainless steel spring with aluminum threaded insert, and use Zinc coated bolt & mounting hardware.

2.05 TAPPING SLEEVES

- A. Tapping sleeves for size on size taps or 12 inch and larger sleeves:
1. Model shall be American Flow Control series 2800-C, Tyler Union, Smith-Blair series 665, Romac style SST III, Ford style FTSS, Ford MJTS, or approved equal.
 2. Ductile Iron Tapping Sleeves.
 - a. Sleeves shall be of construction meeting ASTM A536. Side flange seals shall be O-ring type of round cross-sectional shape.
 - b. All sleeves to include the end joint accessories and split glands necessary to assemble sleeve to pipe.
 - c. Sleeve shall be coated with asphaltic varnish in compliance with NSF-61.
 3. Stainless Steel Tapping Sleeves.
 - a. Sleeves shall be 18-8 type 304 Stainless Steel in accordance with AWWA C223.
 - b. Bolts, nuts, and washers shall be 18-8 Type 304 Stainless Steel. Nuts shall be heavy hex, and coated to prevent galling.
- B. Tapping sleeves smaller than 12 inch which are not size on size:
1. Model shall be Smith-Blair series 665, Romac style SST III, Ford style FTSS, or approved equal.
 2. Sleeves shall be 18-8 type 304 Stainless Steel in accordance with AWWA C223.
 3. Bolts, nuts, and washers shall be 18-8 Type 304 Stainless Steel. Nuts shall be heavy hex, and coated to prevent galling.
- C. Line Stop Tapping Sleeves and appurtenances:
1. Model shall be Hydra-Stop HSF 250 Patriot or approved equal
 2. Body shall be type 304 Stainless Steel in accordance with AWWA C223.
 3. Blind Flange shall be Epoxy Coated Carbon Steel or type 304 Stainless Steel.
 4. Bolts, Nuts and Washers shall be type 304 Stainless Steel.
 5. Completion Plug shall be HSF 250 Push and Pin Style, made of reinforced composite polymer.
 6. Completion Plug O-ring shall be BUNA-N Rubber
 7. Completion Plug Pins shall be SAE Grade 8, Zinc coated to prevent corrosion
 8. Completion Pin Plug shall be type 304 Stainless Steel, coated to prevent galling.
 9. Flange O-Ring shall be BUNA-N Rubber.
- D. All gaskets shall be Nitrile in compliance with NSF-61.
- E. No special tools shall be required other than standard socket wrench.
- F. Flange end pilot dimensions to be in compliance with MSS-Sp-60.

2.06 AIR RELEASE VALVES

- A. Air Release Valves – All air release valves shall be manufactured per ANSI/AWWA C512-04. Cla-Val Series 36 Combination Air Valves, or approved equal. The valves shall be of the size listed in the plans.
1. The combination air valve shall combine the operating features of both an air and vacuum valve and an air release valve in one housing. The air and vacuum valve portion shall automatically exhaust large quantities of air during the filling of the pipeline and automatically allow air to reenter the pipeline when the internal pressure of the pipeline approaches a negative value due to column separation, draining of the pipeline, or other emergency. The air release valve portion shall automatically release small amounts of air from the pipeline while it is under pressure.
 2. The inlet and outlet of the valve shall have the same cross section area. The float shall be guided by a stainless steel guide shaft and seat drip tight against a synthetic rubber seal. 4 inch and larger valves shall have dual guided shafts of hexagonal cross section and a protective discharge hood.
 3. The float shall be of all stainless steel construction and capable of withstanding maximum system surge pressure without failure. The body and cover shall be concentrically located and of ductile iron and the valve internal parts shall be stainless steel or Buna-N rubber.
 4. All 1 inch and 2 inch valves shall be NPT. All valves 4 inch and larger shall be flanged.
- B. Vent piping shall be 2 inch diameter, with copper piping below grade and galvanized piping above grade.
- C. Air vent screens shall be black PVC, with NPT threaded to match the size of the connection pipe. Screen shall be one-piece 304 Stainless, mesh size 100. Silver reflective tape shall be placed on the vent pipe.
- D. An air release valve sign shall be installed on a galvanized 2 pound sign post.
- E. The valve sign shall be aluminum 8 inch x 18 inch (MDOT type III-A) with valve symbol and down arrow of a reflective material.

2.07 REPAIR SLEEVES

- A. All repair sleeves shall be certified NSF/ANSI 61-G and 372, and be in accordance with AWWA C230. Sleeves without service tap shall be Smith – Blair model 226, PowerSeal model 3121, or approved equal. Sleeves with service tap shall be Smith – Blair model 238, PowerSeal model 3131, or approved equal.
- B. Sleeves shall use Type 304 Stainless Steel hardware in accordance with ASTM A193/A194. Sleeves shall have conductivity feature.
- C. The repair sleeves shall be of the full circle type designed to repair a fully broken (completely separated) pipe and shall be rated for a working pressure of not less than 150 psi. Repair sleeves 12 inches or under in size will have a single joint.
- D. The length of the sleeves shall not be less than 7 ½ inches. Sleeves shall have no less than three (3) guide bolts of the minimum specified length. Sleeves of longer length shall have an additional guide bolt for every two (2) inches of additional band length.
- E. Each sleeve shall consist of a sealing gasket, a non-magnetic stainless steel band with contact buttons protruding through specially prepared gaskets, clamp lugs, bolts and nuts.
- F. No welding will be permitted in the manufacture of stainless steel repair sleeves except for the addition of the tap to repair sleeve.

- G. The lugs shall not be deformed in the process of attachments to the band during assembly or during removal in the field.
- H. The gasket shall be natural rubber, nitrile or approved equal and shall be of the tapered overlap design to give a pressure tight fit on the pipe surface to form a leak tight, permanent seal when the repair sleeve is installed. The gasket shall have a grid pattern to conform pipe surface irregularities.
- I. The gasket shall have a stainless steel bridge plate flush mounted and securely bonded into the gasket during the molding of the gasket.

2.08 POLYETHYLENE ENCASEMENT

- A. Polyethylene encasement must be manufactured using 8 mil thick virgin polyethylene in accordance with ANSI/AWWA C105/A21.10. Provide the tube size recommended by the manufacturer to protect the pipe and fitting sizes. Provide adhesive tape for the polyethylene tube as recommended by the manufacturer. Tape for repairing damage to the polyethylene must have a life expectancy equal to or greater than the life expectancy of the polyethylene.

2.09 STEEL BLOW-OFF PIPE

- A. Steel pipe shall be hot dipped galvanized meeting the requirements of ASTM A53.

2.10 WATER SERVICES AND APPURTENANCES

A. Copper Service Lines

- 1. Copper pipe shall be used for service lines which are ¾ inch, 1 ¼ inch and 2-inch. All copper services shall conform to AWWA C800. Water service pipe shall be copper meeting the requirements of ASTM B88, type K.
- 2. All appurtenances on copper service lines shall be flare copper connections. Other connections may be used in lieu of flare copper connections if approved by the Engineer prior to installation.

- B. All water service appurtenances shall meet the requirements of AWWA C800 and be from The Ford Meter Box Company, Inc., A.Y. McDonald Mfg. Co., or as approved by the Engineer. All water service appurtenances for 2 inch and smaller are as follows:

1. ¾ inch services:

- a. Corporation Stop ¾ inch – FB600-3-NL or AY McDonald 74701B NL (3/4 inch)
- b. Service Saddle – Smith-Blair 311(4 to 12 inch water main), Smith-Blair 313 (16 to 24 inch water main), Romac 101U(4 to 12 inch water main), Romac 202SSU (16 to 24 inch water main), Ford F101(4 to 12 inch water main), or Ford F202(16 to 24 inch water main).
- c. Curb Stop (for use when reducing a 1 ¼ inch street service to ¾ inch yard service) – Ford B21-555-NL, C18-35-NL, and C28-33-NL
- d. Curb Stop (when using ¾ inch street service) – Ford B22-333-NL or AY McDonald 76100 NL (¾ inch)
- e. Brass Fittings – All brass fittings such as tees, elbows, caps, nipples and similar items shall be manufactured in the U.S.A.
- f. Couplings – Ford C22-33-NL or AY McDonald 74758 NL (¾ inch)

2. 1 ¼ inch services:

- a. Corporation Stop – Ford FB600-45-NL or AY McDonald 74701B NL (1 x 1 ¼ inch)

- b. Service Saddle – Smith-Blair 311(4 to 12 inch water main), Smith-Blair 313 (16 to 24 inch water main), Romac 101U(4 to 12 inch water main), Romac 202SSU (16 to 24 inch water main), Ford F101(4 to 12 inch water main), or Ford F202(16 to 24 inch water main).
 - c. Curb Stop – Ford B22-555-NL or AY McDonald 76100 NL (1 ¼ inch)
 - d. Brass Fittings – All brass fittings such as tees, elbows, caps, nipples and similar items shall be manufactured in the U.S.A.
 - e. Couplings – Ford C22-55-NL or AY McDonald 74758 NL (1 ¼ inch)
3. 2 inch services:
- a. Tapping Valve – Ford B11-777-NL
 - b. Service Saddle – Smith-Blair 313, Romac 202S, or Ford F202
 - c. Brass Fittings – All brass fittings such as tees, elbows, caps, nipples and similar items shall be manufactured in the U.S.A.
 - d. Couplings – Ford C44-77-NL
4. Water meters – All water meters shall be Neptune Water Meters. They shall be supplied and installed by the City of Kalamazoo.
- C. All water service appurtenances larger than 2 inch shall be in accordance with section 2.01.
- D. All multiple meter settings with more than two meters excluding the fire meter shall use a fabricated meter manifold. Fabricated manifold shall be manufactured as follows:
- 1. Water manifold shall be made using 304 Schedule 40 Stainless Steel pipe.
 - 2. Inlet and outlets shall be threaded or welded flange. End cap shall be welded flange with a blind flange for future additions.
- E. Conduit used as sleeves shall be schedule 40 PVC or approved by Engineer.

2.11 METER SETTINGS

- A. Interior meter settings shall use components from the following manufactures.
- 1. 1 inch meter – Ford KV23-454W-NL Angle Valve, Ford C38-44-2-625-NL, Brass Nipple, Apollo 94ALF-105-01A Ball Valve or approved equal
 - 2. 1½ inch and 2 inch meter – Ford FV13-777W-NL Angle Valve, Ford CF35-66NL (1 ½ inch), Ford CF 35-77-NL (2 inch), Brass Nipple, Watts LFFBV-3C Ball valve or approved equal.
 - 3. 3 inch and larger- rubber seated gate valves meeting the requirements of AWWA C515. Valves shall be American Series 2500 Resilient Wedge Gate Valve with hand wheel by American or equal flanged joint with rubber gaskets (per AWWA/ANSI C 111/A21.11), and be equipped with a hand wheel to operate, Hymax 874-56-03008812 (3 inch), 874-56-04010812 (4 inch), 874-56-06016312 (6 inch), or 874-56-08021712 (8 inch) Flange Adaptor, and flange to plain end ductile or type 304 stainless steel spool piece.
- B. Exterior meter settings shall use components from the following manufactures.
- 1. 5/8 inch meter – Ford V81-22-33-NL
 - 2. ¾ inch meter – Ford V83-22-33-NL
 - 3. 1 inch meter – Ford V84-22-55-NL Copper setter

4. 1 ½ inch and 2 inch meter – Watts LFFBV-3C Ball Valve or approved equal. Ford CF-77-1-937-NL Meter Flange, Ford C28-77-NL Coupler, and Brass Nipple.
5. 3 inch and larger – All above ground or in pits/vaults valves 3 inches and larger shall be rubber seated gate valves meeting the requirements of AWWA C515. Valves shall be American Series 2500 Resilient Wedge Gate Valve with hand wheel by American or equal flanged joint with rubber gaskets (per AWWA/ANSI C111/A21.11), and be equipped with a hand wheel to operate, Hymax 874-56-03008812 (3 inch), 874-56-04010812 (4 inch), 874-56-06016312 (6 inch), or 874-56-08021712 (8 inch) Flange Adaptor, and flange to plain end ductile or type 304 stainless steel spool piece.

2.12 FIRE SERVICE APPURTENANCES

- A. All fire service appurtenances shall meet the requirements of AWWA/ANSI C110/A21.10, AWWA C115, and be from the following manufacturers.
 1. Double Check Valve Detector Assembly – Zurn Wilkins Model 350DA or 350ADA with meter setting, AMES Colt LFC300 with meter setting, or approved equal. The City of Kalamazoo will supply the 5/8 inch water meter.
 2. Reduced Pressure Zone Assembly – When using a RPZ in lieu of double check valve for a backflow device, a Zurn Wilkins Model 375DA or 375ADA with meter setting, AMES Colt LFC500 with meter setting, or approved equal shall be required. The City of Kalamazoo will supply the 5/8 inch water meter.

2.13 METER BOXES AND VAULTS

- A. All Meter Boxes, Meter Vaults and components shall be from the following manufactures.
 1. Box – Hancor MP NL1 24 0008 - 24 inch x 48 inch or ADS24X48MP 24 inchx48 inch white corrugated meter pit or Engineer approved equal.
 2. Vault – Precast concrete meter vault shall have a 3 inch minimum wall thickness and size shall be depended on number of meters and meter size. The wall shall have steps that are equally spaced 12 inches apart. Meter vault shop drawings shall be submitted to the Engineer and approved for each installation.
 3. Meter Pit Cover – Vestal 32-497, 32-055, 32-104, and 32-046 or approved equal.
 4. Meter Vault Cover – Ford MC-24HH-MB-T

2.14 VALVE BOXES AND VAULTS

- A. Curb Stop Boxes for 1 ¼ inch Service – Bingham & Taylor Fig. No. 4901-B, 94-F with 2 ½” New Style Flush Fit Cover or approved equal. Cover shall be inscribed with the word “water”.
 1. Curb Stop Box extensions shall be cast iron and manufactured by Bingham & Taylor, capable of being mounted directly to the curb stop box.
- B. Gate Valve Box or 2 inch Service Box – the valve box shall be of adjustable length screw type. The valve box shall be a malleable iron casting conforming to subsection 908.03 of the 2012 Michigan Department of Transportation *Standard Specifications for Construction*. This valve box shall either be a two or three piece screw type and the cover shall be inscribed with the word “water.” Valve box 8550 Series (two piece) or 8560 Series (three piece) manufactured by EJ, 4905 size no. 22 manufactured by Bingham & Taylor, or approved equal.
 1. Gate Valve Box extensions shall be cast iron and manufactured by EJ or Bingham & Taylor, capable of being mounted directly to the gate valve box.
- C. Valve Vaults for Insta-Valves – Valve vaults used in conjunction with Insta-Valves shall be constructed with materials as detailed in WA-8-A of the City of Kalamazoo Standard Plans.

They shall be of the diameter specified and in accordance with subsection 823.02 of the Michigan Department of Transportation *Standard Specifications for Construction* for Gate Wells.

- D. Valve Vaults for Air Release Valves – Valve vaults used in conjunction with Air Release Valves shall be constructed with materials as detailed in the latest WA-4-Series or WA-5-Series of the City of Kalamazoo Standard Plans. They shall be of the diameter specified and in accordance with subsection 823.02 of the Michigan Department of Transportation *Standard Specifications for Construction* for Gate Wells.

2.15 BACKFILL MATERIALS

- A. Use materials meeting the requirements of section 902 of the 2012 Michigan Department of Transportation *Standard Specifications for Construction*.

2.16 BELL JOINT LEAK CLAMP

- A. Bell Joint Leak Clamps shall be Smith-Blair Model 274, Ford Meter Box FBC or MJSC style, or approved equal.
 - 1. The bell spigot ring, section connector, and range spacer shall be ductile iron 80-55-06 in accordance with ASTM 536. Fusion bonded epoxy finish shall meet application methods per AWWA C213. Spigot ring design shall be interlocking to allow ease of installation without interrupting the flow of the pipe. The bolt head pocket shall be integral for one wrench installation.
 - 2. Gasket shall be Nitrile Buna-N per ASTM D2000, and certified to NSF/ANSI 61-G & 372.
 - 3. Restraint Rods and Nuts shall be Type 304 Stainless Steel. Restraint Rod shall have rolled threads, and Nut shall be fluoropolymer coated to prevent galling.
- B. Bell encapsulating couplings shall be Ford Meter Box MJBE style.
 - 1. The coupling shall be designed to fully encapsulate the pipe bell. The coupling shall be of split mechanical joint design with independent end seal and side seal gaskets.
 - 2. All welded components shall be constructed with ASTM A 36 carbon steel.
 - 3. The end seal and side seal gaskets shall be virgin NBR formulated for water service. The gaskets shall not require field trimming, cutting or modification.
 - 4. The end seal compression ring shall be manufactured with ductile iron per ASTM A 526 Grade 65-45-12 or ASTM A 36 carbon steel.
 - 5. The coupling shall be coated to an average of 12 mills thickness with a fusion-bonded epoxy that is NSF 61 listed and meeting application methods of AWWA C213.

2.17 COUPLINGS

- A. Wide range couplings shall be Romac Alpha or approved equal.
 - 1. All cast components shall be ductile iron, meeting or exceeding ASTM A 536, grade 65-45-12
 - 2. Grippers shall be ductile iron, meeting or exceeding ASTM A 536, grade 65-45-12.
 - 3. Gaskets shall be SBR compounded for water service per ASTM D2000 and meet NSF61 classification.
 - 4. Bolts and nuts shall be 304 stainless steel.
 - 5. Body shall be epoxy coated, and NSF61 Certified.

2.18 STRUCTURE CASTINGS

- A. All 24 inch structure covers shall be a malleable iron casting conforming to subsection 908.03 of the 2012 Michigan Department of Transportation *Standard Specifications for Construction*. The structure cover shall be series 1040 manufactured by EJ, inscribed with the word "Water".

2.19 STEEL CASING PIPE AND APPURTENANCES

- A. Steel casing pipe shall meet the requirements in accordance with subsection 909.05.D of the 2012 Michigan Department of Transportation *Standard Specifications for Construction* with the exceptions listed below:

- 1. For steel casing pipe jacked under a railroad, replace in its entirety the entry for 30 inch nominal size listed in Table 909-18 with the following:

Nominal OD and Wall Thickness in Inches Jacked in Place Steel Pipe

Nominal Size	Nominal Outside Diameter	Wall Thickness
30	30.000	0.406(a)
a. Coated or cathodically protected (0.469 inch minimum if uncoated and unprotected)		

- 2. Steel casing must have a minimum yield strength of 35,000 pounds per square inch (psi) and be in accordance with ASTM A53, Type E or S, Grade A or B and be designed for Cooper E80 loading requirements. In all cases, the allowable jacking strength capacity of the casing pipe shall be capable of withstanding the maximum jacking forces imposed by the operation.

- B. Stainless steel band spacer shall be Advance Products & Systems model SSIM or approved equal. The bands shall be constructed of circular stainless steel bands, which bolt together forming a shell around the carrier pipe. The spacers shall be designed with runners to support the carrier within the casing and maintain a minimum clearance of 1.00 inches between the casing inside diameter (ID) and the spacer outside diameter (OD). The spacers shall contain four modular runners – two on each half. Stainless steel bolts, nuts and washers shall be supplied with the casing spacers.

The band shall be manufacture of 8 inch wide 14-guage T-304 stainless steel. Abrasion resistant runners, having a minimum length of 7 inches and a minimum width of 1 inch, shall be attached to each band to minimize friction between the casing pipe and the carrier pipe as it is installed. Runner material shall be of glass filled polymer with compression strength of 33,000 psi, flexural strength of 40,000 psi, and tensile strength of 27,000 psi. The ends of thall runners shall be beveled to facilitate installation over rough weld beads or the welded ends of misaligned or deformed casing pipe.

Interior surfaces of the circular stainless steel band shall be lined with PVC, or EPDM alternate, having a minimum thickness of .090 inches with a harness of Durometer "A" 85-90.

Recommended position of the spacers is one placed not more than one foot from each end of the casing and pipe joint. Subsequent spacers shall be placed every 6-8 feet apart thereafter.

- C. Casing end seal shall be Advance Products & Systems model AC or approved equal. Pull-on casing end seals shall be manufactured of 1/8 inch thick neoprene rubber assuring excellent chemical resistance and resiliency. End seals must be effectively used in the temperature range of -20 degrees to 190 degrees Fahrenheit. End seals shall include ½ inch wide T304 stainless steel bandings with 100% nonmagnetic worm gear mechanism. End seals shall be seamless, have vulcanized edges, and can be pulled on at the time of construction.

PART 3 EXECUTION

3.01 CONSTRUCTION

- A. The plans show the locations of existing utilities in accordance with available data. If the work requires precise information on the location of existing utilities, the Contractor will expose utilities shown on the plans to determine the actual locations.

Do not disturb or cut into existing in-service water mains. If the operation of valves in existing water mains is required, notify the City of Kalamazoo a minimum of 3 working days in advance. Coordinate scheduling of water main connections with the City of Kalamazoo. Secure the Engineer's or authorized representative's approval of the schedule before beginning the work.

The City of Kalamazoo will open or close in service valves and provide on-site inspections for all water main and water service installations. The City of Kalamazoo will perform this work for an estimated time and material charge. The cost of opening and closing valves and on-site inspection will need a separate contract with the City of Kalamazoo prior to start of work. This does not apply to work being contracted by the City of Kalamazoo.

Minimize the out of service time for existing water mains. Make connections at night, on Sundays, or on holidays, as conditions require or as approved by the City of Kalamazoo. Minimize interference with the water supply if abandoning existing water mains and incorporating new water mains into the water system.

No trees or permanent structures shall be placed within 10 feet of the centerline of the water main or service line.

3.02 TRENCH EXCAVATION

- A. Excavate water main trenches to the lines and grades shown on the plans in accordance with modifications approved by the Engineer, or authorized representative, or to meet or bypass existing utility structures. Excavate trenches to the depths shown on the plans to provide 5 feet of cover from top of water main to the final grade. Excavate trenches to the widths shown on Michigan Department of Transportation Standard Plan R-83 Series.
- B. Excavate the bottom of the trench to the required grade to allow 6 inches of bedding for the pipe. Do not block under the pipe.
- C. Maintain trenches for water mains free of ground or surface water by pumping or as otherwise approved by the Engineer or authorized representative
- D. Install, and later remove, temporary timber bracing, as required to prevent movement or damage to new or existing water mains or adjacent utilities.
- E. During backfilling, carefully remove supports for sheeted and braced excavations to prevent earth banks or adjacent streets from collapsing.
- F. The Contractor may leave sheeting and bracing in place during backfilling and remove after completing backfilling operations. The Contractor may leave sheeting and bracing in place, if approved by the Engineer and the Contractor cuts it off 5 feet below the ground surface.

3.03 DISPOSAL

- A. Dispose of waste material as specified in section 205 of the 2012 Michigan Department of Transportation *Standard Specifications for Construction*.

3.04 LAYING OF THE PIPE

- A. Install the pipe joint restraint system in accordance with the manufacturer's recommendations, or as directed by the Engineer. Assemble the pipe in the trench. If deflections at joints are required by changes in grade, alignment, or to plumb valve stems, ensure deflections of bell and spigot joints and mechanical fitting joints do not exceed three-quarters of the maximum deflection recommended by the joint manufacturer or that allowed by AWWA C600, whichever is less. Do not store or leave tools or other objects in the pipe.
- B. Provide restrained joints as indicated on the plans. No tie rods or thrust blocks shall be allowed unless approved by the Engineer or authorized representative.
- C. Proper actuation of the gripping wedges of the mechanical joint restraint shall be ensured with torque limiting twist off nuts.
- D. The Contractor shall provide a written statement of warranty (Warranty Bond) for a period of 2 years from the date of **final acceptance (after meter is installed)**. Warranty work shall cover any necessary cost to repair water main or appurtenance leaks and water main or appurtenance leak damage at no cost to the City of Kalamazoo. Final acceptance will only be given **once the water service meter is installed**.
- E. Pipe shall be laid with bell ends facing the direction of laying, unless otherwise directed by the Engineer or authorized representative. When pipe is laid on a grade of 10 percent or greater, the laying shall start at the bottom and proceed upward with the bell ends of the pipe upgrade.
- F. Install silicon bronze wedges between all push-on joint pipes to allow for underground location and thawing of pipeline. 4 to 6 inch pipe shall use 2 wedges, 8 to 12 inch pipe shall use 3 wedges, and 16 inch and above shall use 4 wedges at each pipe joint.
- G. Pipe shall be restrained in accordance with Table 3.1.

Table 3.1 Pipe Thrust Restraint Table

NON-POLYWRAPPED PIPE								
Pipe Size (Inches)	90° Bend	45° Bend	22.5° Bend	11.25° Bend	Tee*	Reducer (One Size)	Reducer (Two Sizes)	Dead End
4	44	18	9	5	42	-	-	42
6	62	26	13	7	59	31	-	59
8	82	34	17	9	78	33	56	78
10	100	42	20	10	94	32	58	94
12	119	50	24	12	110	33	59	110
16	157	65	32	16	143	61	85	143
20	195	81	39	20	173	61	109	173
24	233	97	47	23	204	61	111	204
30	288	120	58	29	246	86	134	246
POLYWRAPPED PIPE								
Pipe Size (Inches)	90° Bend	45° Bend	22.5° Bend	11.25° Bend	Tee*	Reducer (One Size)	Reducer (Two Sizes)	Dead End
4	62	26	13	7	60	-	-	60
6	88	37	18	9	84	44	-	84
8	117	49	24	12	111	47	80	111
10	142	59	29	14	133	45	82	133
12	170	71	34	17	158	47	84	158
16	224	93	45	23	203	87	121	203
20	278	116	56	28	247	87	155	247
24	332	138	66	33	291	87	159	291
30	411	171	82	41	351	123	191	351
* Length of restraint for branch; use the size of the branch Consult Engineer for scenarios not included in table.								

3.05 INSTALLATION OF PIPE INVOLVING HORIZONTAL DIRECTIONAL DRILLING

- A. Horizontal direction drilling (HDD) is a method of trenchless construction using a surface launched steerable drill tool controlled from a mobile drilling frame, and includes a field power unit, drilling fluid mixing system, and mobile spoils extraction system. The work generally consists of three phases:
 - 1. Drilling a pilot hole from the surface or pit at a starting point to an exit pit at the surface beyond the obstacle or area that is to be avoided.
 - 2. Reaming the pilot hole to make it large enough for the pipeline to be installed.
 - 3. Pipeline is pulled into place. During the pipe pulling operation, drilling fluid (a bentonite, water, and polymer solution) is injected to stabilize the hole, remove cuttings, and lubricate the pipe.
- B. Coordination

1. Drilling operations shall not interfere with, interrupt or endanger surface features or surface activities.
2. When rock stratum, boulders, underground obstructions, or other soil conditions that impede the progress of drilling operation are encountered, the Contractor and Engineer shall review the situation and jointly determine the feasibility of continuing drilling operations, making adjustments or switching to an alternative construction method.
3. The contractor shall familiarize themselves with the geologic characterization of the soil stratum at the proposed drilling path. The Contractor shall be responsible for informing the Engineer of any changes that are required in the directional drilling procedure due to geologic conditions.
4. Launching and recovery pits shall be as small as practical. Dewatering of pits and excavations shall be done in accordance with the City of Kalamazoo Standard Specifications. When groundwater is encountered, the Contractor shall provide a dewatering system of sufficient capacity to keep any excavation free from water until the backfill operation is in progress. Dewatering shall be performed in a manner that removal of soil particles is held to a minimum. Water from the dewatering system shall be desilted before discharge. Methods of dewatering and desilting, including all costs shall be the Contractor's responsibility and are included in the Horizontal Directional Drilling Water Main pay item.
5. Utilities shown on the plans are approximate. In areas where there is a potential conflict, the Contractor shall dig up and verify the locations and elevations of the utilities at no additional expense to the City. The Contractor shall assume full responsibility for the protection fall utilities, structures and their foundations which may be affected by the work.
6. Before beginning the drilling process, the Engineer shall stake the proposed drill path.

C. Drill Path Survey

1. The Drill path shall be walked in the presence of the Engineer and the Contractor with the guidance system that shall be used for each segment of drill path. The contractor shall locate and record any surface and subsurface magnetic variations or abnormalities and all points of interference, as well as verifying all utility locations and corresponding utility maps. Should any discrepancies arise between utility maps, field locations and guidance system findings, the Contractor shall clarify all discrepancies prior to beginning drilling operations. The drill path survey shall be performed no earlier than two days prior to commencing drilling operations. Provide the Engineer 48-hour notice of drill path survey.

D. Equipment

1. The drilling equipment shall be capable of placing the pipe within the planned line and grade without inverted slopes.
2. The drilling equipment shall be capable of pulling product pipe from either the downstream or upstream pit locations. The equipment must be adequately sized for the application.
3. The guide system shall have the capability of measuring inclination, roll and azimuth. The guidance system shall have an independent means to ensure the accuracy of the installation. The Contractor shall demonstrate a viable method to eliminate accumulated error due to the inclinometer (pitch or accelerometer). The guidance

system shall be capable of generating a plot of borehole survey for the purpose of a record drawing. The guidance system shall meet the following specifications:

Inclination:	Accuracy	+0.05
	Range	+90
	Repeatability	+0.02
Roll:	Accuracy	+0.05
	Range	+90
Azimuth	Accuracy	+0.05
	Range	+90

4. Equipment setup requirements at the launch and recover locations shall be determined by the Contractor in accordance with the Plans and shall be submitted to the Engineer prior to commencement of drilling operations.

E. Pilot Hole Drilling

1. The entry angle of the pilot hole and the drilling process shall maintain a curvature that does not exceed the allowable bending radii of the carrier pipe per the manufacturer's recommendations.

F. The contractor shall follow the pipeline alignment as shown on the Plans, within the specification requirements. The location and depth of the drill head in relation to the profile and centerline of the alignment shall be determined at a maximum of ten-foot intervals. Acceptable tolerance shall be 0.5 feet variation from the centerline of the pipe in both vertical and horizontal directions (1-foot tolerance window).

G. In the event of difficulties at any time during drilling operation requiring the complete withdrawal from the tunnel, the Contractor shall either be allowed to withdraw and abandon the tunnel and begin a second attempt at a different location. The alternate locations shall be approved by the Engineer before the Contractor withdraws.

H. Access pits shall be at the beginning and end segments shown on the Plans. Intermittent pits shall be approved by the Engineer prior to proceeding with drilling operations. No intermittent access pits shall be allowed in Railroad Right of Ways.

I. Installing the Carrier Pipe:

1. After the pilot hole is completed, the Contractor shall install a swivel to the reamer and commence pullback operations.
2. Reaming diameter shall not exceed 1.5 times the diameter of the carrier pipe being installed.
3. The carrier pipe being pulled into the tunnel shall be protected and supported so that it moves freely and is not damaged by stones and debris on the ground during installation.
4. Pullback forces shall not exceed the allowable forces for the carrier pipe.

J. The Contractor shall allow sufficient lengths of carrier pipe to extend past the termination point to allow connections to adjacent pipe sections, tees, or fittings. Pulled pipe shall be allowed 24 hours of stabilization prior to making tie-ins. The length of extra carrier pipe shall be at the Contractor's discretion.

K. Field Inspection

1. All pipe sections, specials, and jointing materials shall be carefully examined for defects and no piece shall be laid that is known to be defective. Any defective piece discovered installed shall be removed and replaced with a sound one in a manner satisfactory to the Engineer at the Contractor's expense.
2. Defective material shall be marked with an "X" in pink paint and shall be removed from the job site.

L. Drilling Fluid Containment and Disposal Requirements

1. The contractor shall contain, handle, and dispose of drilling fluids in accordance with the following requirements:
 1. All drilling fluid and fluid additives shall be disclosed, and Material Safety Data Sheets (MSDS) shall be provided to the permit agency and the Engineer upon request.
 2. Excess drilling fluid shall be confined in a containment pit at the entry and exit location until recycled or removed from the site.
 3. Precautions shall be taken to ensure that drilling fluid does not enter the roadways, streams, municipal storm or sanitary sewer lines, and/or any other drainage system or body of water.
 4. When installing below railroads, vents shall be installed on either side of the railroad tracks to direct any excess drilling fluid to a containment area and to prevent unintended surfacing of drilling fluid within the Railroad Right of Way.
 5. Unintended surfacing of drilling fluid shall be contained at the point of discharge and recycled or removed from the site.
 6. Drilling fluids that are not recycled and reused shall be removed from the site and disposed at an approved disposal site.
 7. Drilling fluids shall be completely removed from the construction site prior to backfilling or restoring the site.

3.06 ABANDONING WATER MAINS

- A. Remove and dispose of abandoned pipe, gate boxes, or other appurtenances, as necessary for placement of a new water main at no additional cost to the City of Kalamazoo. Remove portions of gate boxes to at least 3 feet below the pavement surface under the road, and to at least 12 inches below the planned grade outside the road. If the Engineer determines abandoned mains may remain in place, cap the end of pipe with cap and megalug or as directed by the Engineer or authorized representative. If shown on the plans or directed by the Engineer or authorized representative, fill abandoned water mains with non-structural flowable fill.

3.07 VALVES

- A. Prior to installation, all valves shall be fully operated open and close to verify its functionality and number of turns. Set and join valves to the water mains as required for cleaning, laying, and jointing the required type of pipe, as shown on the plans. Install valves as required by the contract, or as approved by the Engineer. Place the valve stems plumb. Install valves to not bear on the pipe. Install anchor coupling with valves installed on tees or crosses, with swivel gland located on the valve side of the anchor coupling.
- B. When installing 12 inch and larger valves (Butterfly Valves), the operating nut shall be located on the side of the valve furthest from the centerline of the roadway, unless otherwise directed by the Engineer.

3.08 LIVE TAPS TO IN SERVICE WATER MAINS

- A. Prior to tapping of the main contractor shall disinfect all pipe, appurtenances, tapping machine with chlorinated water.
- B. Contractor shall install all necessary tapping appurtenances according to manufacturer's recommendation.
- C. Contractor shall use equipment which allows the tapping machine to rinse out metal shavings and tap water main per manufacturer's recommendations. No tap 4 inches or larger shall be allowed within 4 feet from any joint, fitting, or exiting tap regardless of location of tap. 1 ¼ inch taps located within 10 feet of previous tap shall be offset 15 degrees.
- D. Once tapping is complete Contractor shall disinfect all exposed water main and appurtenances with chlorinated water.

3.09 VALVE BOXES.

- A. Provide valve boxes that do not transmit shock or stress to the valve. Place valve boxes plumb over the operating nut of the valve, with the box cover flush with the pavement, or as approved by the Engineer or authorized representative. Provide firm support for valve boxes.
- B. Valve boxes shall be installed, centered and plumbed over the operating nut of the gate valve. The area around the valve box shall be back-filled with Granular Material Class II placed in layers not to exceed 12 inches, and thoroughly compacted to the required density. The Contractor shall take due care to prevent the box from shifting during backfilling operations. The tops of the valve boxes shall be flush with the established pavement or ground surface.

3.10 ADJUSTING OR RECONSTRUCTING WATER SHUT OFFS OR VALVE BOXES

- A. Adjust and reconstruct water shutoffs or valve boxes to the final grade or as approved by the Engineer or authorized representative. Replace shutoff or gate box materials damaged during adjustment or reconstruction, as determined by the Engineer, or authorized representative, at no additional cost to the City of Kalamazoo.

3.11 WATER SERVICES

- A. Water Services shall not be connected to the water main until approved by the Engineer or authorized representative.
 - 1. The standard size for all new services shall be 1 ¼ inch. The property owner/developer may request a larger size if needed.
 - 2. ¾ inch service materials may only be used when performing repairs or partial replacements of an existing ¾ inch service, or when replacing the yard service of a ¾ inch service. When replacing a complete street side service of a ¾ inch service, a new 1 ¼ inch tap will be completed, new 1 ¼ inch street service line installed, and reduced down at the curb shut off per section 2.10.
- B. Tap water main per section 3.08.
- C. When more than two meters excluding the fire meter are required to be set on a single service line, a fabricated meter manifold shall be installed.
- D. Water Services 2 inch and Smaller
 - 1. Construct services from the distribution main to the water meter. Lay services in a straight line perpendicular to the water main unless approved by the Engineer or authorized representative. Construct service with a continuous piece of copper from the corporation stop to the curb stop and curb stop to the water meter unless

approved by the Engineer or authorized representative. Services over 300 feet will require an exterior meter setting (meter pit).

2. All couplings shall be located as close to the water main as possible, but outside roadway unless approved by the Engineer.
3. The use of thread sealant shall be not be allowed on flare fittings.
4. No splices shall be allowed for 1 ¼ inch or smaller yard services 90 feet and shorter in length.
5. Tap and curb shut off locations shall be no closer than 5 feet to edge of driveways. If a service is required to be abandoned due to improper location, service shall be fully abandoned at the water main tap location and new service installed the developer's expense. Corporation stop shall be shut off, copper piping removed, and copper disc installed on the corporation stop.
6. If finish grade changes from plan grade after installation of service, curb shutoff shall be adjusted to 5 foot bury depth at the developer's expense.
7. When the street service is installed separately from the yard service a copper disk shall be installed on the yard side of the curb valve per the manufactures recommendations as approved by the Engineer or authorized representative.

E. Water Services Greater than 2 inch

1. For services entering a building with no basement, install the stand pipe flange 12 inch from the finished floor elevation and 6 to 12 inches away from any walls. Install the flange pipe so two bolt holes are parallel from each wall (two hole). For services entering a building with a basement or into a concrete vault, install the stand pipe flange 6 to 12 inches off the wall. Install the flange pipe so that two bolt holes are parallel to the floor, normal to the wall. For all services entering a building, the service line shall be located in room located on an outside wall of the building, with enough room to maintain the service.
2. Contractor shall complete installation of service prior to pressure testing and disinfection. The Contractor shall hydrostatic test the complete fire service from the nearest outside valve to first valve (OS&Y) before installing the fire check valve per section 3.22. Service shall be cleaned, flushed and tested per section 3.23. No connection shall be made to these services until after pressure test is complete and consecutive negative bacterial test results have been received in accordance with sections 3.22 and 3.23 of this specification, and the water main approved by the Engineer or authorized representative.
3. No adapter flange or grooved pipe joint shall be used on any portion of the service to be maintained by the City of Kalamazoo, with the exception of the meter side of an OS&Y fire service valve.
4. For service lines with multiple meter settings, a valve the same size as the incoming service line shall be installed prior to the tee or manifold. If one of the meter settings is for a fire service, the valve shall be an OS&Y valve in accordance with section 2.02.F.

F. Construct the service pipe with at least 5 feet of cover, unless Engineer or authorized representative requires additional depth.

G. Make all service connections, and transfers. Maintain and protect, at no additional cost, existing service connections requiring transfer, but not shown on the plans, until reconnection or disposal.

- H. If relocating a portion of water service, shut down the water service by method approved by the Engineer or authorized representative.
- I. Service lines entry points into the structure shall be sealed with hydraulic cement or mastic putty and oakum to prevent groundwater infiltration. For ductile iron pipe services, link seals should be used as the preferred method.
- J. FIRE SERVICES
 - 1. The Contractor shall notify the Engineer or authorized representative a minimum of 3 working days prior to flushing the fire service or testing the fire system capacity.
 - 2. All fire services shall have an OS&Y valve meeting the requirements of 2.02.F installed. The sample tap on the OS&Y Valve shall be installed on the downstream side of the valve.
- K. INTERIOR METER SETTINGS (PREFERED)
 - 1. Interior valve and meter inlet connection shall be installed by the Contractor in accordance with the Engineer, or authorized representative's recommendations and final approval.
 - 2. The meter setting shall be located in a heated portion of the building. The meter setting shall not be located in a crawl space, above electrical appliance, or near an electrical panel. A clear and unobstructed access to the meter of not less than 24 inches by 24 inches shall be provided.
 - a. 1 ¼ meter settings must be placed in basements. Meter setting shall be placed in the front of the building facing the street or within three feet of the front on the side unless otherwise approved by the Engineer or authorized representative. Water Services shall not be placed under footings. If service enters house under the porch and the porch footing extends below water service, a 2 inch PVC sleeve will be required.
 - b. A ½ inch schedule 40 PVC conduit, or larger, shall be installed from the meter setting to the remote reading point. There shall be no more than 75 feet of conduit between pull boxes. There shall be no more than four (4) 90-degree bends between pull boxes. All pull boxes must be installed no more than 96 inches above the floor. Pull boxes shall not be installed in attics or crawl spaces.
 - 3. The City of Kalamazoo will install the meter, readout, readout wire, copper ground wire, outlet meter connection and valve.
- L. EXTERIOR METER SETTINGS
 - 1. Exterior meter settings shall be installed by the Contractor according to the Engineer's or authorized representative's recommendations, and in accordance with City of Kalamazoo Standard Plans. Meter settings will be required for services greater than 300 feet, slab on grade, crawl spaces, where minimum 5 foot bury depth cannot be maintained, and other reasons. Contractor shall verify proper meter location with the Engineer prior to construction.
 - 2. Meter boxes or vaults shall not be installed in any street, alley, parking area, driveway, or sidewalk. Major landscaping (shrubs, boulders, etc.) and structures (retaining walls, fences, buildings, etc.) shall not be placed within seven and a half (7.5) feet or trees shall not be planted within ten (10) feet of any meter box or vault, unless otherwise directed by the Engineer.

3. The ground surrounding meter boxes, pits and vaults shall slope away from the lid at a minimum grade of 2%
4. No plumbing or electrical connections will be allowed inside the meter box or vault, unless otherwise directed by the Engineer.
5. All tees, connections, and couplings shall be a minimum of five (5) feet downstream from the meter box or vault wall on the outlet side. Tees and connections shall not be installed between the curb stop and the meter setter or copper horn.
6. Meters shall be installed by the City of Kalamazoo upon inspection and acceptance of the meter setting.
7. Meter boxes shall be used for all 1 inch exterior meter settings. The Contractor shall install meter boxes to horizontal location and to final grade as determined by grade stakes. Meter boxes shall be installed 5 feet outside the right of way in private property. All work shall be in accordance with the current WS-8 of the City of Kalamazoo Standard Plans.
8. For services 1 ¼ inch and smaller, curb shutoffs shall be located in the right of way, centered in the curb lawn area, or as directed by the Engineer.
9. The Contractor shall install meter vaults for 1 ½ inch and larger meter settings.
10. Meters shall be installed by the City of Kalamazoo upon inspection and acceptance of the meter setting.

3.12 WATER MAINS, CUT AND PLUG

- A. All work related to water main, cut and plug shall be in accordance with section 3.06.A. If the plans show cutting and plugging water mains, arrange for the City of Kalamazoo to shut down the main. Remove the section of pipe and plug the water main as shown on the plans or as approved by the Engineer or authorized representative. Construct the required restraint as directed by the Engineer or authorized representative.

3.13 FIRE HYDRANTS

- A. Set fire hydrants at the locations shown on the plans and in accordance with City of Kalamazoo standard plans and manufacturer's recommendations or as coordinated with the City of Kalamazoo. When installed, the hydrant shall be located on the side of the water main furthest from the centerline of the roadway, unless otherwise directed by the Engineer. Equip the hydrant with auxiliary valves, as shown on the plans. Stand hydrants plumb, with side nozzles parallel to the curb, and with the pumper nozzle normal to the curb, unless otherwise directed by the Engineer. Place the nozzles at the height specified by the City of Kalamazoo.
- B. For all gate valves connected adjacent to a tee or hydrant, the anchor between the fitting or hydrant and the valve shall be a 6 inch by 13 inch swivel by solid adapter with swivel gland. The swivel gland shall be located on the hydrant side of the solid adapter.
- C. Install a valve box over hydrant valve in accordance with section 3.09.
- D. Hydrants shall have a protective cover placed over hydrants prior to backfilling to ensure the hydrant is not damaged. If hydrant is damaged, the contractor shall repair or replace the hydrant at no cost to the City.
- E. If site conditions are such that it is not desirable for hydrant drain into the surrounding soil (i.e. when hydrant has less than 10 feet of separation from a sewer, high ground water, impervious or contaminated soils, etc.), hydrant drip valve plug(s) shall be installed by the Contractor onsite. Final determination on drip valve plug installation shall be made by the

Engineer or his representative. As constructed records shall be noted whether or not the drip valve plug was installed.

3.14 FIRE HYDRANT MARKER

- A. The sign shall be located between the hydrant and curb and offset from the pumper nozzle, or as directed by the Engineer. The sign shall be placed 3 feet away from the hydrant. The sign shall be single sided or double sided as directed by the Engineer or authorized representative. The sign shall have an installed height to the bottom of the sign of 7 feet above the final grade in areas with sidewalk and 5 feet above the final grade in areas without sidewalk.
- B. A fire hydrant mounted whip may be installed in addition to fire hydrant sign if approved by the Engineer. Fire hydrant whip shall be mounted to the fire hydrant opposite the pumper nozzle in accordance with the manufacturer's specifications.

3.15 FIRE HYDRANT REMOVAL

- A. If the plans show removal of a fire hydrant, remove the entire hydrant assembly, including the following:
 - 1. Auxiliary gate valve and box, unless otherwise approved by the Engineer or authorized representative.
 - 2. Internal valve assembly;
 - 3. Top bonnet;
 - 4. Standpipe; and
 - 5. Hydrant inlet body, unless otherwise approved by the Engineer.
- B. If the City of Kalamazoo approves leaving the auxiliary gate valve and box in place, remove to at least 3 feet below the pavement surface under the road, or at least 12 inches below planned grade outside the road.
- C. Stockpile the removed material at a location accessible to the City of Kalamazoo. The City of Kalamazoo will maintain ownership of the hydrant, and will remove the assembly from the project site

3.16 RELOCATING FIRE HYDRANTS

- A. If the plans show relocating a hydrant, arrange for the City of Kalamazoo to shut down the hydrant auxiliary valve. Remove the hydrant and reinstall at the required location. Reconnect the hydrant to the water main by shutting down the main, tapping a new hydrant outlet, or using the existing outlet. Install piping as required. If the relocated hydrant does not pass testing the hydrant shall be replaced with new at no cost to the City of Kalamazoo.

3.17 MISCELLANEOUS FITTINGS

- A. Install the following at the locations shown on the plans and in accordance with good construction practices and manufactures recommendations:
 - 1. Elbows,
 - 2. Tees,
 - 3. Corporation stops,
 - 4. Blow offs,
 - 5. Pipe adapters,
 - 6. Pipe couplings,

7. Retaining glands, and
8. Other miscellaneous fittings.

3.18 AIR RELEASE VALVES AND VAULTS

- A. Construct air release valves and vaults in accordance with the current WA-4-Series and WA-5-Series of the City of Kalamazoo Standard Plans.
- B. When installing the air release valves in conjunction with new water main construction, the contractor shall use ductile iron fittings.
- C. When installing the air release vaults as a retrofit to existing water main, live taps may be performed as directed by the engineer.

3.19 BACKFILLING AND COMPACTING

- A. Backfill and compaction shall be in accordance with Michigan Department of Transportation Standard plan for utility trenches R-83-Series.
- B. Backfilling Under Existing Conduits – Where it is necessary to undercut or replace existing utility conduits and/or service lines, the excavation beneath such lines shall be backfilled the entire length with granular bedding material tamped in place in 6-inch layers to the required density. The granular bedding shall extend outward from the spring line of the conduit a distance of 2-feet on either side and thence downward at its natural slope.
- C. Backfilling with Excavated Material – Unless otherwise specified or directed, material excavated in connection with the work shall be used for backfilling and other filling purposes, if it meets all requirements given elsewhere in this specification.
- D. Backfill Immediately Following Inspection – All trenches and excavations shall be backfilled immediately after pipe is laid therein, unless otherwise directed by the Engineer or authorized representative. Under no circumstances shall water be permitted to rise in un-backfilled trenches after pipe has been placed.
- E. Service leads shall not be backfilled until the pipe ends are referenced and the Engineer or authorized representative has measured the pipe for payment.
- F. Backfilling around and over structures and pipes shall be carefully done by hand and tamped with suitable tools of approved weight to a point 1-foot above the top of pipe. Selected material or, where specified or ordered by the Engineer, special backfill material shall be used in this area. The material shall be placed in uniform layers not exceeding 6-inch in depth up each side. Each layer shall be placed, then carefully and uniformly tamped to the specified density so as to eliminate the possibility of lateral displacement of pipe or structure.
- G. Backfilling by Machinery – After the backfill has been placed and compacted around the boxes and pipe to a height of 1-foot above the top. The remainder of the trench may be backfilled by machine. The backfill material shall be deposited in horizontal layers and each layer shall be thoroughly compacted to the specified density by approved methods before a succeeding layer is placed. In no case will backfill material from a bucket be allowed to fall directly on a structure or pipe and in all cases the bucket must be lowered so that the shock of the falling material will not cause damage.

3.20 COMPACTION REQUIREMENTS

- A. Compact each layer to 95% (90% if outside the influence of the roadway) maximum density as tested by the Michigan Department of Transportation Density Testing and Inspection Manual.

3.21 COMPACTION TEST

- A. Trenches and excavation around structures shall be backfilled and consolidated in layers, as specified, to the existing ground surface. Compaction tests shall be performed on each layer immediately after compaction.
- B. Initial test series for each type of backfill material shall be continued until the method of consolidation employed has proven to attain the required compaction. Any change in the proven method of consolidations will require additional testing and field verification of compaction.
- C. Subgrade below pavements, curbs, sidewalks, and structures shall be consolidated as specified. Compaction tests shall be performed to verify specified consolidation.

3.22 HYDROSTATIC TESTING

- A. Perform hydrostatic testing of water mains in accordance with AWWA C600.
- B. Ensure City of Kalamazoo personnel witness pressure testing. Give the City of Kalamazoo personnel at least 1 full working day notice before testing.
- C. Provide the personnel, temporary timber bracing, plugs, test pumps, temporary connections to the Municipal water system, and any other required apparatus. Provide the water for hydrostatic testing if not available from the City of Kalamazoo. Water must be pumped from a measurable source in order to determine testing allowance water.
- D. Before applying test pressure, expel air from the pipe in increments of no greater than 1,000 feet. Pressure test each section of water main. If the Contractor chooses not to pressure test against an existing valve, a new valve may be installed at the expense of the Contractor.
- E. Pipe shall be pumped with water to a minimum test pressure of 150 pounds per square inch (psi) at the highest point of elevation to begin test. Test shall last for at least 2 hours, with a maximum drop of pressure of 5 psi. If the pressure drop is greater than 5 psi but less than 20 psi, a testing allowance water test shall be performed. Testing allowance water, as measured by the quantity of water pumped into the pipe to attain the pressure at which the test began must not exceed the testing allowance.
- F. Testing allowance water is determined using the following formula

$$L = \frac{SD\sqrt{P}}{148,000}$$

Where

- L= testing allowance water in gallons per hour
- S= length of pipe in feet
- D= actual pipe diameter in inches, and
- P= 150 psi

- G. If testing allowance water is above the allowable limit occurs during hydrostatic testing, remove backfill to expose pipe and repair the joints. Repeat testing after repairs are complete. If multiple leaks occur the contractor may be required to reinstall main at Contractors expense.
- H. Correct visible leaks regardless of the amount of leakage. Replace faulty pipes, fittings, gate valves, or other accessories disclosed by testing. Repeat the test until the pipes, fittings, gate valves, and other accessories meet the requirements.

3.23 DISINFECTION, FLUSHING, AND BACTERIOROLOGICAL TESTING

- A. Disinfect the water main in accordance with AWWA C651 and applicable Michigan Department of Environment, Great Lakes, and Energy (EGLE) regulations after successful hydrostatic testing.
- B. Disinfect and flush new, and portions of existing, water mains as required by the EGLE.
- C. Use blow offs, fire hydrants, or other means as shown on the plans or approved by the Engineer, or authorized representative, to flush water mains in accordance with AWWA C651, with a velocity of at least 3 feet per second. Provide hoses and other equipment and arrange a means of disposing of the water without damaging the work or adjacent property.
- D. Use the continuous feed method with chorine added simultaneously with the water. Add chlorine or liquid hypochlorite to meet the requirement of at least 25 milligrams per liter of chlorine. Slowly add the water to the main and allow it to stand for at least 24 hours. At the end of the 24-hour period, ensure the chlorine residual is a minimum of 10 milligrams per liter. If not met, re-chlorinate and flush the water main until a minimum 10 milligrams per liter residual remains after 24 hours.
- E. After completing disinfection, initially flush the water mains with water at a velocity of at least 3 feet per second to replace the entire volume of chlorinated water in the pipeline. After initial flushing, perform final flushing until the residual chlorine content meets the standard level for the water distribution system. The City of Kalamazoo may require a waiting period after flushing and before bacteriological sampling.
- F. Dispose of chlorinated water in accordance with applicable state and local requirements. If necessary, apply a reducing agent to the water to neutralize the chlorine and create a chlorine residual of no greater than 1 ppm. Dechlorination shall be in accordance with AWWA C655.
- G. After flushing, perform bacteriological testing in accordance with AWWA C651 and EGLE requirements. Test chlorine residuals before taking each bacteriological sample. Ensure the chlorine residual is less than 1.5 milligrams per liter before taking a bacteriological sample. The City of Kalamazoo will collect samples from each branch of pipe in the presence of the Engineer, or authorized representative, and contractor personnel. The City of Kalamazoo will be responsible for the transportation of the samples to a State of Michigan approved lab for testing. Two consecutive bacteriologically safe tests at 24-hour intervals for each section of pipe are required. Acceptable tests are negative for bacteria and as otherwise defined by AWWA C651 and EGLE regulations.
- H. If a bacteriological test fails, repeat disinfection, flushing, and testing.
- I. Pressure and chlorination taps shall be removed within one business day of passing tests, so main can be activated.

3.24 POLYETHYLENE ENCASEMENT

- A. Polyethylene encasement will be required for all ductile iron installations when the soil test evaluation is greater than or equal to 10 points based as indicated in AWWA/ANSI C105/A21.5 or as directed by the Engineer. Sampling of the soils is to be completed by the developer or municipality responsible for the installation.
- B. Install polyethylene encasement on water mains and fittings installed through concrete floor and foundations and as indicated on the plans in accordance with the manufacturer's installation instructions and AWWA/ANSI C105/A21.10. Appropriately sized polyethylene encasement shall be used so that there are no longitudinal splices. This may require using one or more size larger diameter encasement than the pipe installed.

- C. Polyethylene encasement shall be required for all installations when groundwater is detected in the utility trench.
- D. Polyethylene encasement shall be required for all directional drilling installations involving ductile iron pipe.

3.25 WATER INFRASTRUCTURE IN STEEL CASING

- A. Work shall be performed in accordance with section 401 of the Michigan Department of Transportation *Standard Specifications for Construction* and as detailed herein. In all cases, the Contractor shall submit a work plan detailing the following:
 - 1. Means and methods for bracing and shoring;
 - 2. Methods of maintaining and adjusting line and grade;
 - 3. Drilled/bored diameter;
 - 4. Drill hole stabilization procedures;
 - 5. Size and location of the auger head relative to the casing;
 - 6. Methods of dealing with cobbles/boulders and obstructions;
 - 7. Estimated jacking thrust required;
 - 8. Method of monitoring casing elevation;
 - 9. Thrust block design calculations;
 - 10. Record keeping system to document casing advance and jacking pressures;
 - 11. Grouting procedures;
 - 12. Temporary dewatering measures and;
 - 13. Mitigation procedures if sinkholes or settlement above the pipe occurs or excessive movement of the settlement monitors is observed.
- B. Minimum Allowable Depths.
 - 1. The minimum allowable depth of the Horizontal Auger Bore (HAB) installed casing pipe shall be in accordance with Table 3.2

Table 3.2 Minimum Allowable Depths Table	
Location	Minimum Depth
Base of Rail	6 Feet
Existing Ground	5 Feet
Roadway	5 Feet
Ditch Flowline	5 Feet

- C. Access Pits.
 - 1. Excavate jacking and receiving pits as necessary. Provide and install all sheeting, shoring, bracing and any other earth retention measures in accordance with section 704 of the Michigan Department of Transportation *Standard Specifications for Construction*. Provide site drainage and subsurface dewatering and other items associated with the operation as necessary to facilitate the proposed work.
- D. Lead Auger/Overcut Allowance.

1. A full-size auger section shall be used as the lead section of the casing. The auger shall not protrude from the leading edge of the casing. However, if soil conditions halt the movement of the casing, the auger shall be allowed to protrude not more than 1 inch in front of the casing during the boring operation. Overcut is the annular space between the excavated hole and the outside diameter of the casing pipe. The allowable overcut diameter is one inch greater than the casing pipe radius.
- E. Watertight joints.
1. Watertight joints are required to ensure the integrity of the road and railroad bed. Casing pipe shall be constructed to prevent water leakage or earth infiltration and must be certified free from any breaks or leaks throughout its entire length.
- F. Lubrication Fluids.
1. Lubrication fluids are specifically required for this method regardless of the soil conditions. Any deviations from the use of lubrication shall require prior approval for the Engineer. The Contractor shall install vents on either side of the casing pipe to prevent fracking during installation. These vents shall also be used as relief in case of a water main break. Lubrication fluids, consisting of a mixture of water and bentonite or bentonite/polymer, shall be used in the annular space between the casing being installed and the native soil to stabilize and lubricate the drill hole. Grease will not be allowed for use as lubrication for this purpose.
- G. Pipe Locating and Tracking.
1. One of the following tracking, locating, and guidance systems shall be used:
 - a. Waterline system.
 - b. Mechanical control head.
 - c. Electronic (inertial) control head.
 - d. Walkover system.
 - e. Laser guided tunnel attachment.
 - f. Laser guided pilot rod.
 2. The Contractor will be responsible for submitting their proposed pipe locating tracking method at the preconstruction meeting for approval.
- H. Settlement/Heaving Monitoring.
1. Settlement/Heaving monitoring shall be performed in a manner that will minimize the movement of the ground in front of, above, and surrounding the horizontal auger bore operation; and will minimize subsidence of the surface above and in the vicinity of the boring. The ground shall be supported in a manner to prevent loss of ground and keep the perimeter and face of the boring stable at all times, including during shutdown periods. A survey shall be performed one day prior to initiating this operation at each required monitoring location. A similar survey shall then be performed at each location, on a daily basis, until the permitted activity has been completed. All survey readings shall be recorded to the nearest one-hundredth (0.01) of a foot. Digital photographs of the pavement and rail conditions shall also be taken prior and after the pipe installation. Specific monitoring locations and requirements may also be provided for railway crossings.
- I. Ground Water Control.

1. Dewatering shall be conducted whenever there is a high ground water table level to prevent flooding and facilitate the operation. The water table elevation shall be maintained at least 1 foot below the bottom of the casing at all times. When needed, dewatering may be initiated prior to any excavation.
2. Minor water seepage or pockets of saturated soil may be effectively controlled through bailing or pumping. This control shall be accomplished without removing any adjacent soil that could weaken or undermine any access pit, its supports, or other nearby structures.
3. Larger volumes of ground water shall be controlled with one or more well points or with staged deep wells. Well points and staged deep well pumping systems shall be installed and operated without damage to property or structures, and without interference with the right of the public, owners of private property, pedestrians, vehicular traffic, or the work of other contractors. Any pumping methods used for dewatering and control of ground water and seepage shall have properly designated filters to ensure that the adjacent soil is not pumped along the water. Well diameter, well spacing and the pump's pumping rate shall provide adequate draw down of the water level. Wells shall be located to intercept ground water that otherwise would enter the access pit excavation and interfere with the work. Upon removal of a well, the hole shall be filled and grouted.
4. Existing storm sewers shall only be used to discharge water from the dewatering operation in accordance with a permit obtained from the appropriate storm sewer owner. Filters or sediment control devices shall be required to ensure that the existing system is not adversely affected by construction debris or sediment.

J. Casing End Seals/Bulkheads

1. Casing ends shall be enclosed using 1/8 inch thick synthetic rubber casing ends seals in accordance with section 2.19.C of this document. Ensure end seals are water tight and attach securely to the casing pipe and the carrier pipe (water main). Ensure end seals are acceptable to the Engineer.

K. Backfill Requirements.

1. Remove the pits and backfill the excavations as necessary with material meeting the standard specifications as approved by the Engineer.

L. Railroad Specific Requirements.

1. For Steel casing pipe jacked in place under a railroad, the following will apply in accordance with the current AREMA Manual;
 - a. When steel casing pipe is used, the joints must be fully closed by welding or mechanical means as approved by the Engineer.
 - b. Minimum cover over the casing must be at least 6.0 feet from the bottom of the railroad tie to the top of the casing pipe at its closest point.
 - c. Casing pipe must extend beyond the limits of the entire railroad right-of-way.
 - d. Jacking construction requirements must be in accordance with the current AREMA Manual, Chapter 1, Part 4.

3.26 INSTALLATION OF LINE STOPS AND INSERTION VALVES

- A. Line Stops and Insertion Valves shall be performed in the locations as detailed on the plans or as directed by the Engineer. Prior to installation of the line stop or insertion valve, coordinate the deactivation of the water main so that all customers have been given proper notification

of the shutdown. No work shall be performed without the Engineer or authorized representative present.

B. Excavate and expose the water main. Remove scale from the water main and make sure there are no flaws which would affect the seal with the saddle.

C. Line Stops

1. Install permanent line stop body on the pipeline and perform line stop according to manufacturer's instructions. Upon completion of the work associated with the line stop, reactivate the water main and install permanent blind flange on the line stop body. Ensure that all as built information is recorded and submitted as detailed in section 1.03.

D. Insertion Valves

1. Install Insertion Valve body on the pipeline and perform valve insertion according to manufacturer's instructions. Operate the valve to ensure that it is fully functional.

2. Construct valve vault as detailed in WA-8-A of the City of Kalamazoo Standard Plans. Ensure that all as built information is recorded and submitted as detailed in section 1.03.

3.27 FINAL RESTORATION

A. Contractor shall restore site to preconstruction condition or better, or as detailed on the plans.

B. Final grade shall be 5 feet above completed water main or water service line, unless otherwise approved by the Engineer. If final grade is changed greater than 6 inches from the approved plans, the Developer or Contractor shall raise or lower water main and water services so that they are maintained at 5 feet below final grade. All costs associated with this work shall be paid for by the Developer or Contractor.

PART 4 MEASUREMENT AND PAYMENT

4.01 PAY ITEMS

Measurement a payment may not apply if construction is not being funded with City of Kalamazoo funds. Please review signed construction contract for actual measurement and payment specifications.

Pay Item	Pay Unit
Water Main, DI __ inch, Tr Det __	Foot
Water Main, DI __ inch, in Casing.....	Foot
Water Main, DI __ inch, HDD.....	Foot
Gate Valve and Box, __ inch,.....	Each
Butterfly Valve and Box, __ inch.....	Each
Polyethylene Encasement.....	Foot
Water Main, __ inch, Cut and Plug	Each
Fire Hydrant	Each
Hydrant, Rem	Each
Hydrant Relocate, Case __	Each
Water Serv	Each
Water Serv, Long.....	Each
Water Serv, Conflict	Each
Water Serv, Yard	Each
Copper Tubing, Additional Length	Foot
Water Serv, 2 inch.....	Each
Water Serv, Conflict, 2 inch	Each
Copper Tubing, Additional Length, 2 inch	Foot

Steel Casing Pipe, __ inch, Jacked in Place.....Foot

4.02 MEASUREMENT OF PAY ITEMS

- A. Payment for Water Mains shall be measured based on the sizes and trench details required, along the centerline of the pipe, with no deductions for fittings. The unit price of Water Main, DI, includes the cost of the following:
 - 1. Excavation and backfill;
 - 2. Dewatering operations (trench and/or pipe);
 - 3. Provide temporary water system to maintain service during construction;
 - 4. Hydrostatic testing;
 - 5. Disinfecting and flushing the water main and bacteriological testing;
 - 6. All material, labor and equipment necessary to remedy an unsatisfactory hydrostatic test, including removing and replacing any backfill;
 - 7. Providing and installing fittings, gaskets, bracing or sheeting, blocking and miscellaneous items for installing pipe and reconnecting to the Municipal Water System;
 - 8. Preparing and providing as-constructed plans.

- D. The City of Kalamazoo may withhold payment and/or final acceptance until the City of Kalamazoo accepts the as-built plans.

- E. The cost of dewatering of trenches, pipe, or both associated with alterations to the Municipal Water System, is included in the unit price for relevant items of work.

- F. The cost of excavating, disposing of excess material, and providing, placing, and compacting the backfill, is included in the unit price for related items of work.

- G. The cost of removing or abandoning existing water mains, gate valve boxes, and other appurtenances to provide clearance for the proposed water main or roadway, is included in the unit price for relevant items of work.

- H. Payment for Gate Valves, Butterfly Valves, and Valve Boxes, shall be as follows:
 - 1. The unit prices of **Gate Valve and Box** and **Butterfly Valve and Box**, of the types and sizes required, include the cost of providing and installing the valve and valve box, complete and ready for use.

- I. Payment for water services 1 ¼ and smaller shall be as follows:
 - 1. **Water Serv** refers to services between the water main and the curb shut off no greater than 33 feet long. **Water Serv, Long** refers to services between the water main and the curb shut off greater than 33 feet long and up to 66 feet in length. **Water Serv, Yard** refers to the services between the curb shut off and the water meter setting, up to 25 feet in length. **Copper Tubing, Additional Length** refers to the additional copper tubing and work needed when services between the curb shut off and the water meter setting are over 25 feet in length, and when the length of the service between the center of the road and the curb shut off exceeds 66 feet. **Water Serv, Conflict** refers to relocating only a portion of a water service.

- J. Payment for water services 2 inches in size shall be as follows:
 - 1. **Water Serv, 2 inch** refers to the services between the water main and the water meter setting no greater than 58 feet in length. **Water Serv Conflict, 2 inch** refers to relocating only a portion of a 2 inch water service. **Copper Tubing, Additional length, 2 inch** refers to the additional copper tubing and work needed when services exceed 58

feet in length.

- K. Services with a diameter larger than 2 inches will be measured and paid for as water mains.
- L. The unit prices for **Water Serv, Water Serv, Long, Water Serv, Yard, Copper Tubing, Additional Length, Water Serv Conflict, Water Serv, 2 inch, Water Serv Conflict, 2 inch,** and **Copper Tubing, Additional Length, 2 inch**, include the cost of the following, unless otherwise accounted for in other pay items:
 - 1. Earth excavation;
 - 2. Removing pavement;
 - 3. Replacing pavement;
 - 4. Jacking and boring;
 - 5. Providing and installing type K copper tubing, service saddle, corporation stops, service stops, and service boxes;
 - 6. Disinfecting;
 - 7. Providing, placing, and compacting backfill;
 - 8. Slope Restoration to equal or better conditions; and
 - 9. Miscellaneous material, equipment, or operations.
- M. Payment for additional service connections, not shown on the plans, but maintained, protected, and reconnected or disposed of by the Contractor will be paid for as **Water Serv**, or **Water Serv, Long**.
- N. The pay item **Water Serv, Conflict** will apply only to portions of water services requiring relocation due to direct conflict with utilities, other items of work, or as otherwise approved by the City of Kalamazoo. Payment for all other relocations requiring replacement of corporation or service stops will be paid for as Water Serv or Water Serv, Long.
- O. Payment for **Water Main, __inch, Cut and Plug** includes the cost of cutting the existing water main, providing and placing the required plug, and thrust blocks.
- P. Payment for **Fire Hydrant** includes the cost of providing and installing the hydrant, hydrant valve, valve box, and all pieces between the valve and hydrant, including the coarse gravel and concrete base, fire hydrant marker at the locations shown on the plans in a ready-for-use condition unless noted otherwise.
- Q. Payment for **Hydrant, Rem** includes the cost of breaking down the auxiliary gate valve, gate box, the hydrant assembly, backfilling, and plugging the opening in the existing main.
- R. Payment for **Hydrant, Relocate, Case __** (of the case required), includes the cost of vertically adjusting the relocated hydrant to final grade and the following:
 - 1. Case 1 includes the cost of removing the hydrant, extending the existing hydrant lead from the gate valve, reinstalling the hydrant in a ready-for-use condition, adjusting the existing gate box and hydrant to final grade, and providing and installing sleeves, fittings, and joint restraints.
 - 2. Case 2 includes the cost of removing the existing hydrant, gate valve and box, and reinstalling the hydrant and gate valve in a ready-for-use condition, adjusting the existing gate box and hydrant to final grade, and providing and installing the cutting-in-sleeve, pipe coupling, tee, elbow, and joint restraints.
- S. Payment for **Steel Casing Pipe, __inch, Jacked in Place** of the size required will be paid for by the length installed. The unit price for **Steel Casing Pipe, Jacked in Place** includes the cost of excavating the pits, providing and installing sheeting, bracing, and any other safety devices, providing jacking equipment: drainage and dewatering; bulkheading and sealing the casing, providing and installing vents, grouting the annular space between the casing and native soil and any other items associated with the operation.

- T. Payment for **Water Main, DI, __inch, in Casing**, of the size required will be paid for by the length installed. The unit price for **Water Main, DI __inch, in Casing** shall include the cost for furnishing and installing the water main and casing spacers inside the casing.
- U. Payment for **Water Main, DI, __inch, HDD**, of the size required will be paid for by the length installed. The unit price shall include the cost of all equipment and materials, excavation and backfill, dewatering operations (trench, pit or pipe), temporary water system to maintain service during construction, hydrostatic testing, disinfecting and flushing the water mains, and bacteriological testing, all materials, labor and equipment necessary to remedy and unsatisfactory hydrostatic test, including removing and replacing any backfill, providing and install all, gaskets, bracing or sheeting, blocking and miscellaneous items for installing pipe of the required size and material and reconnecting to the water system as shown on the plans.

END OF SECTION

This page was intentionally left blank.

WA-1-D

ITEM	QTY.	#	DESCRIPTION
1	1	39887	6" HYDRANT W/CARROLL DRAIN
2	2	70000	CONNECTING PIECE (13")
3	4	33801	6" GASKET (MJ)
4	1	96696	6" GATE VALVE (MJ)
5	1	08550	VALVE BOX BOTTOM
6	1	08520	VALVE BOX TOP SECTION
7	1	08500	VALVE BOX RING CASTING
8	1	08490	VALVE BOX COVER
9	1	91440	6" TEE MJ
10	1	91525	8" X 6" TEE MJ W/MEGALUGS
11	1	91750	10" X 6" TEE MJ W/MEGALUGS
12	1	91825	12" X 6" TEE MJ W/MEGALUGS
13	1	91909	16" X 6" TEE MJ W/MEGALUGS
14	1	91940	20" X 6" TEE MJ W/MEGALUGS

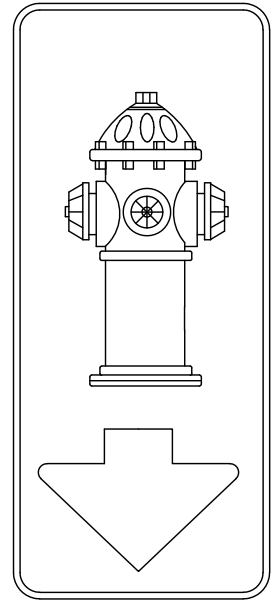

TYPICAL HYDRANT SIGN

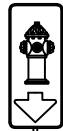

DOUBLE SIDED HYDRANT SIGN

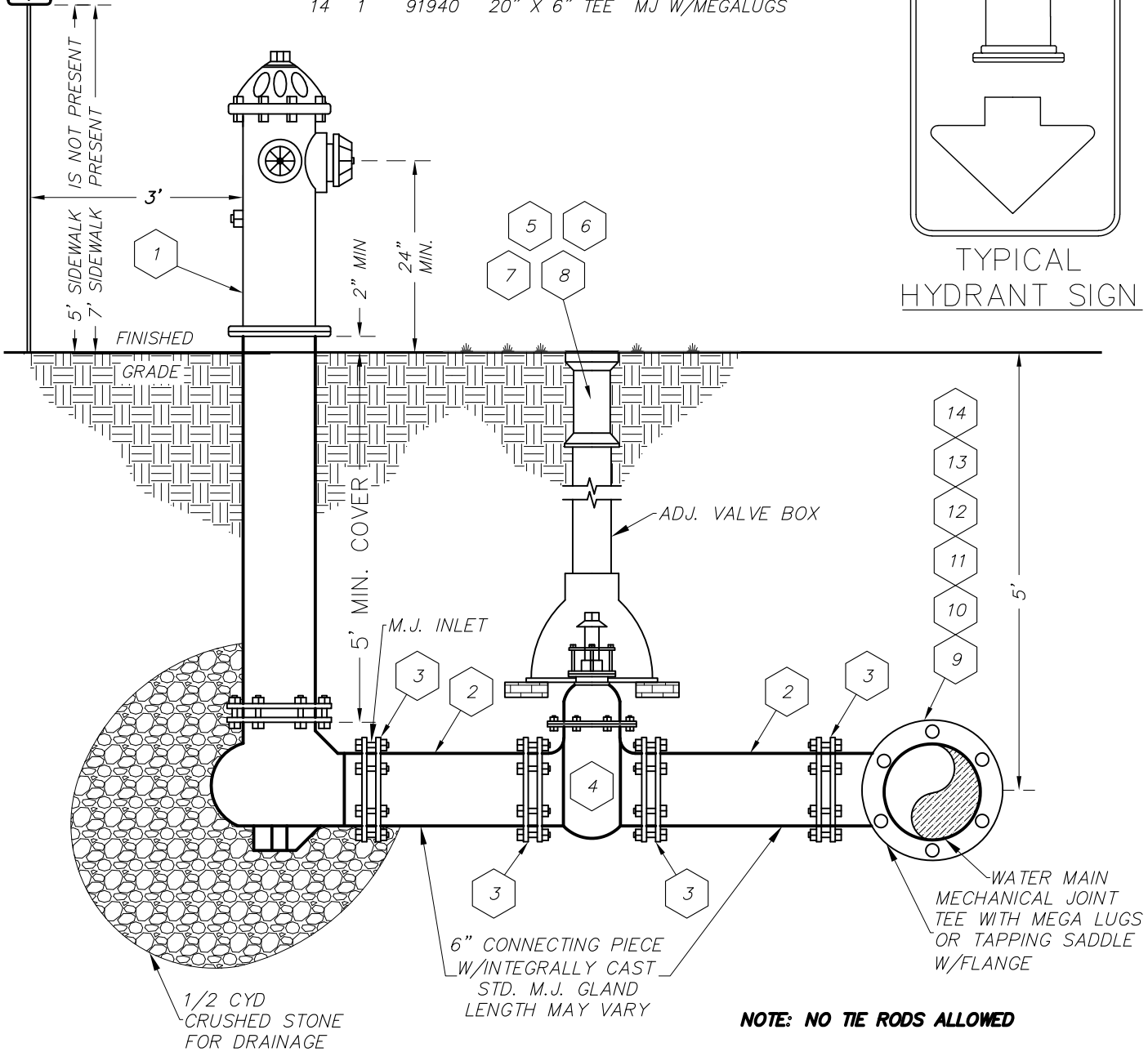

NOTE: NO TIE RODS ALLOWED



CITY OF KALAMAZOO
Department Of Public Services

TYPICAL FIRE HYDRANT & GATE VALVE DETAIL

	DATE
RECOMMENDED BY _____	
APPROVED BY _____	
APPROVED BY _____	
ACCEPTED BY _____	

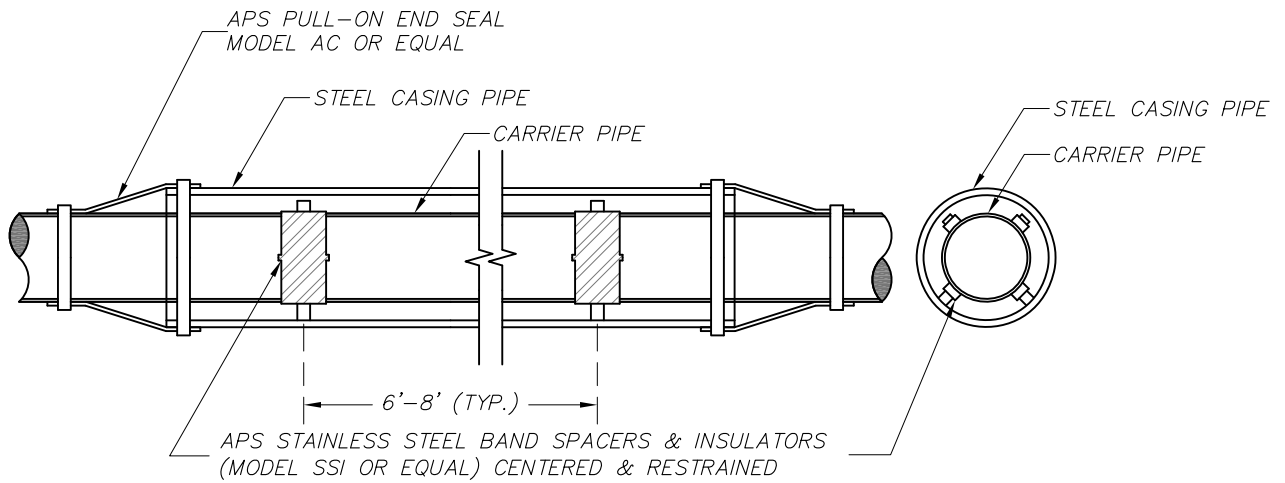

CASING CARRIER PIPE DETAIL

SIZE CASING AND CARRIER PIPES PER PLAN AND SPECIFICATIONS

TYPICAL BAND SPACER POSITIONING:
 ONE PLACED NOT MORE THAN 1 FOOT FROM EACH END OF THE CASING AND
 PIPE JOINTS WITH SUBSEQUENT SPACERS PLACED EVERY 6-8 FEET THEREAFTER.
 FOR 18 FOOT PIPE THERE SHALL BE THREE BAND SPACERS.
 FOR 20 FOOT PIPE THERE SHALL BE FOUR BAND SPACERS.



CITY OF KALAMAZOO
 Department Of Public Services

CASING CARRIER PIPE

RECOMMENDED BY _____	DATE _____
APPROVED BY _____	
APPROVED BY _____	
ACCEPTED BY _____	

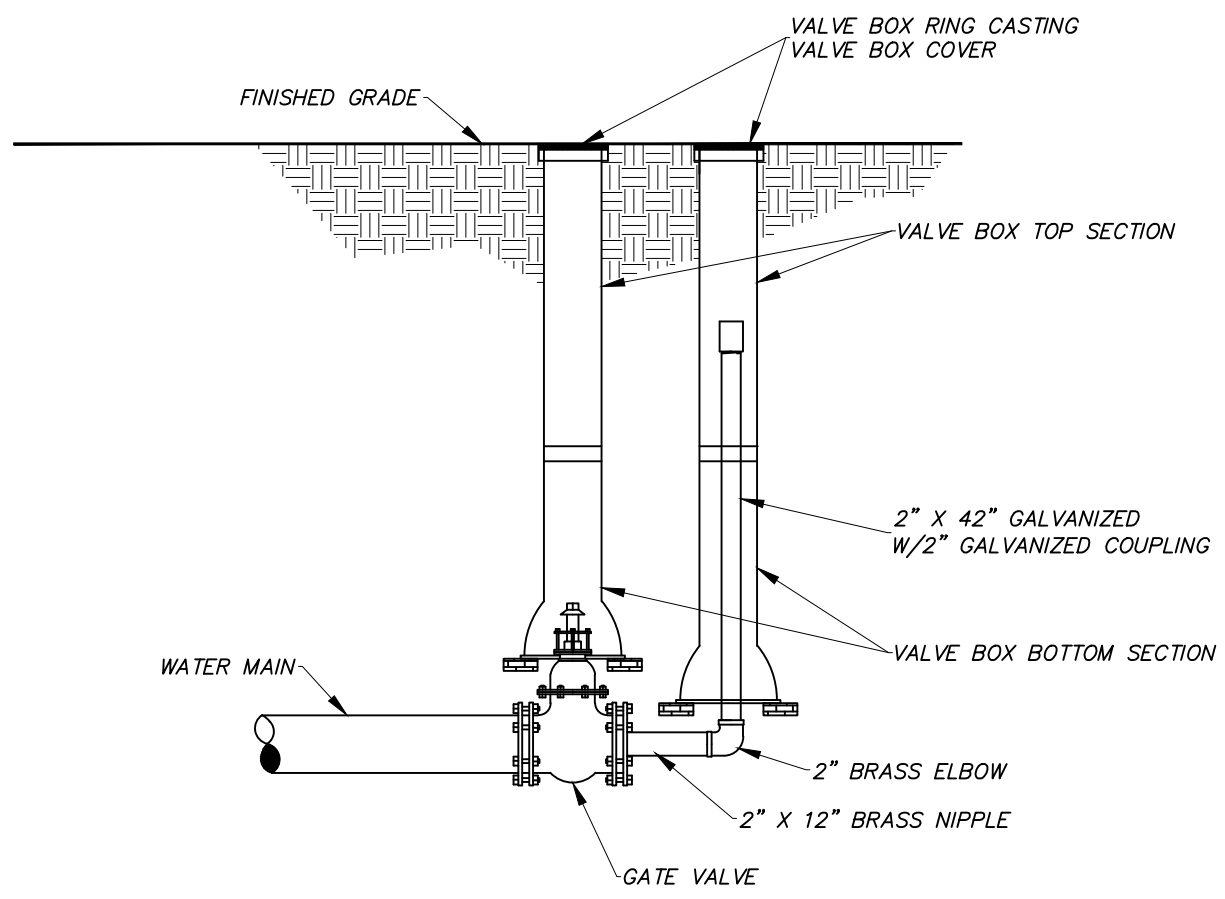

NOT TO SCALE

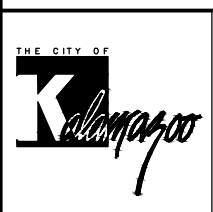

CITY OF KALAMAZOO
Department Of Public Services

2" BLOW OFF CONNECTION

RECOMMENDED BY _____	DATE _____
APPROVED BY _____	
APPROVED BY _____	
ACCEPTED BY _____	

NOTE:
LIFT HOLES SHALL BE FILLED
IN WITH NON-SHRINK MORTAR

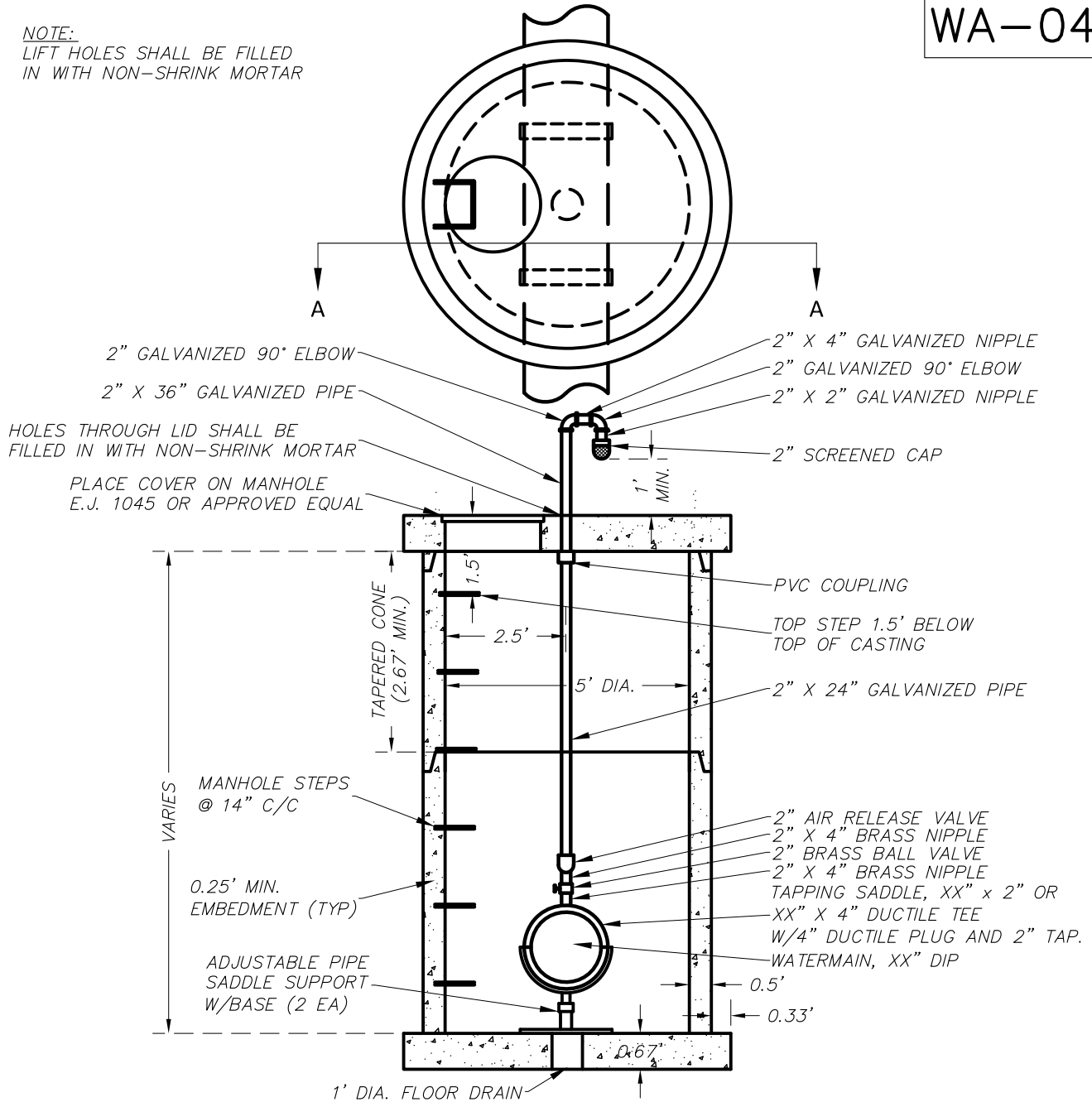

TYPICAL 2" AIR RELEASE MANHOLE

PRECAST REINFORCED CONCRETE SHOWN (OTHER OPTIONS INCLUDE CONCRETE BLOCK, BRICK OR CAST IN PLACE WALL SECTIONS)

SCHEDULE OF FITTINGS

ITEM DESCRIPTION	QUANTITY
AIR RELEASE VALVE, 2"	1
GALVANIZED PIPE, 2" X 60"	1
GALVANIZED NIPPLE, 2" X 4"	1
GALVANIZED NIPPLE, 2" X 2"	1
GALVANIZED 90° ELBOW, 2"	2
PIPE SUPPORT BASE	2

ITEM DESCRIPTION	QUANTITY
TAPPING SADDLE, XX X 2"	1
BRASS BALL VALVE, 2"	1
BRASS NIPPLE, 2" X 4"	2



CITY OF KALAMAZOO
Department Of Public Services

AIR RELEASE MANHOLE

RECOMMENDED BY	DATE
APPROVED BY	
APPROVED BY	
ACCEPTED BY	

WA-05-C

NOTE:
LIFT HOLES SHALL BE FILLED
IN WITH NON-SHRINK MORTAR

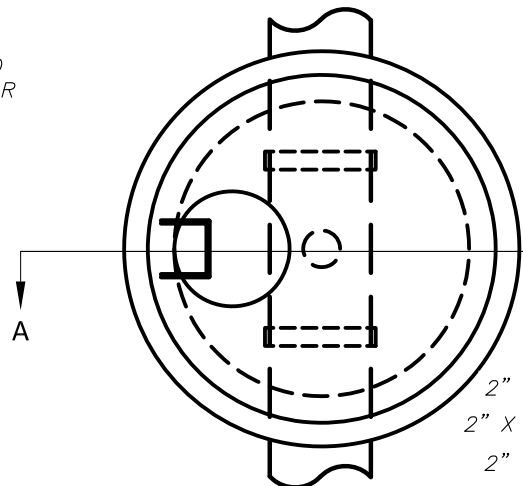

- 2" GALVANIZED 90° ELBOW
- 2" X 4" GALVANIZED NIPPLE
- 2" GALVANIZED 90° ELBOW
- 2" X 2" GALVANIZED NIPPLE
- 2" SCREENED CAP

BOLLARD POSTS
AS SPECIFIED
BY ENGINEER

PLACE COVER ON MANHOLE
E.J. 1045 OR APPROVED EQUAL

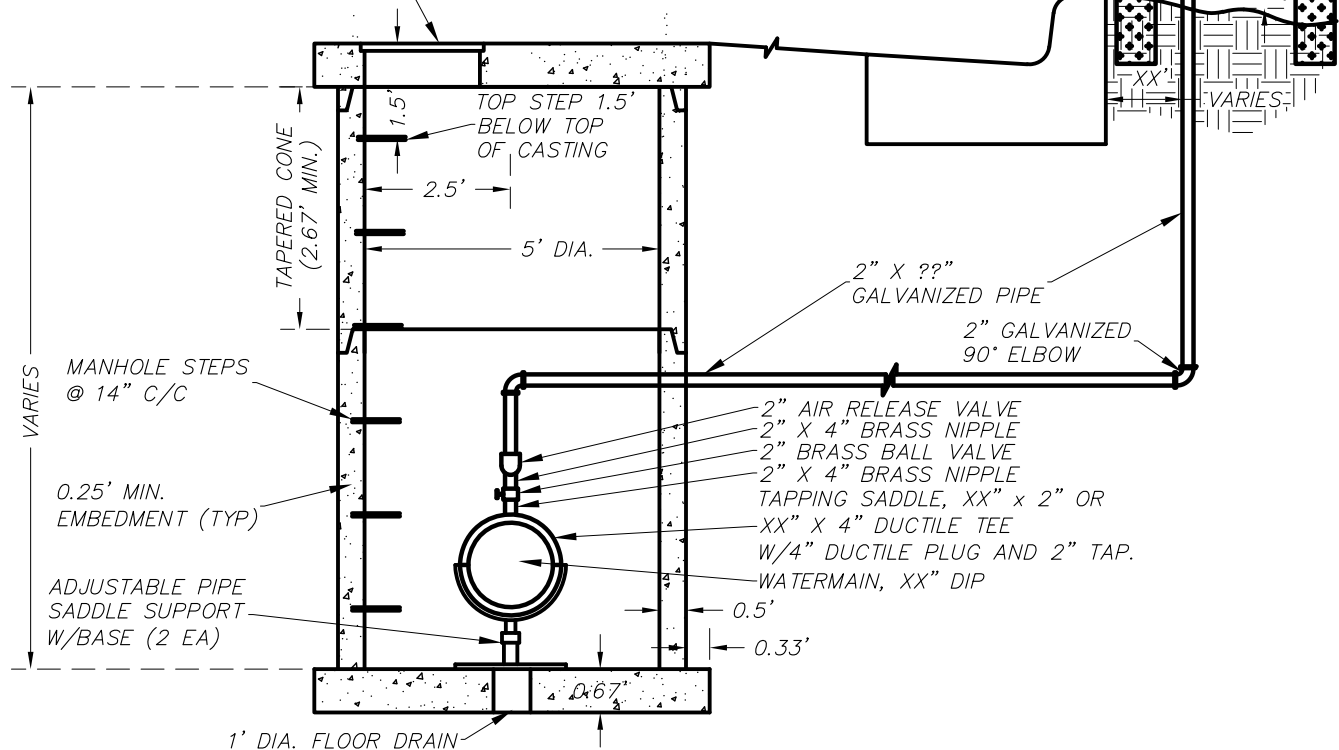

TYPICAL 2" AIR RELEASE MANHOLE

PRECAST REINFORCED CONCRETE SHOWN (OTHER OPTIONS INCLUDE
CONCRETE BLOCK, BRICK OR CAST IN PLACE WALL SECTIONS)

SCHEDULE OF FITTINGS

ITEM DESCRIPTION	QUANTITY
AIR RELEASE VALVE, 2"	1
GALVANIZED PIPE, 2" X 60"	1
GALVANIZED NIPPLE, 2" X 4"	1
GALVANIZED NIPPLE, 2" X 2"	1
GALVANIZED 90° ELBOW, 2"	2
PIPE SUPPORT BASE	2

ITEM DESCRIPTION	QUANTITY
TAPPING SADDLE, XX X 2"	1
BRASS BALL VALVE, 2"	1
BRASS NIPPLE, 2" X 4"	2

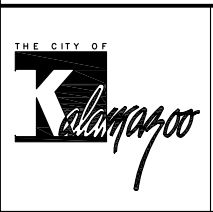

CITY OF KALAMAZOO
Department Of Public Services

AIR RELEASE MANHOLE IN ROADWAY

RECOMMENDED BY	DATE
APPROVED BY _____	
APPROVED BY _____	
ACCEPTED BY _____	

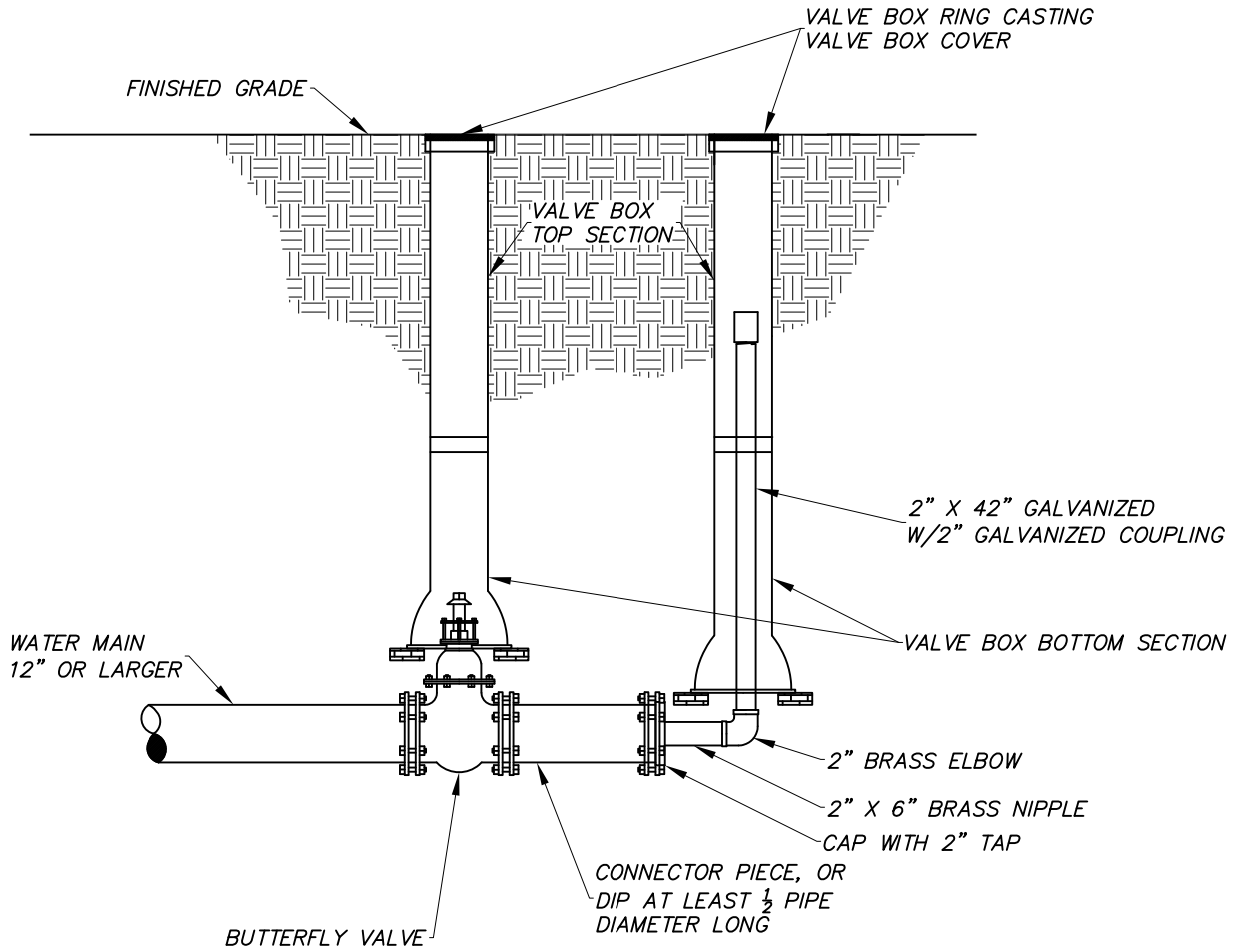

NOT TO SCALE



CITY OF KALAMAZOO
Department Of Public Services

**2" BLOW OFF
CONNECTION
12" OR LARGER MAIN**

RECOMMENDED BY _____
APPROVED BY _____
APPROVED BY _____
ACCEPTED BY _____

DATE

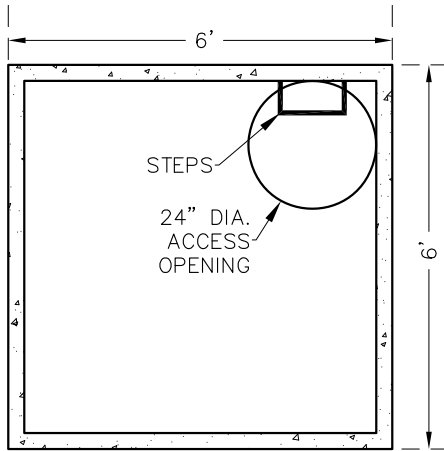

TOP VIEW

NOTES:

1. METER VAULT DESIGN TO BE SUBMITTED AND APPROVED FOR EACH INDIVIDUAL INSTALLATION. DESIGN SHALL CONFORM TO KALAMAZOO WATER ENGINEERING STANDARDS LATEST REVISION.
2. THE DISTANCE BETWEEN RUNGS, CLEATS AND STEPS SHALL NOT EXCEED 12 INCHES AND SHALL BE UNIFORM THROUGHOUT THE LENGTH OF THE LADDER.
3. PLACEMENT OF CURB BOX CAN VARY FROM A MAXIMUM OF 5 FEET OUTSIDE THE PROPERTY LINE TO A MAXIMUM OF 5 FEET INSIDE THE PROPERTY LINE. PLACEMENT OF THE CURB BOX OUTSIDE THE PROPERTY LINE IS PREFERRED.
4. ACCESS COVER - FORD MC-24-MB-T WITH AN INNER LID, VESTAL 32-055, 32-104, AND 32-046 OR APPROVED EQUAL.

TOP OF PIT TO FINAL GRADE SHALL NOT EXCEED 8"

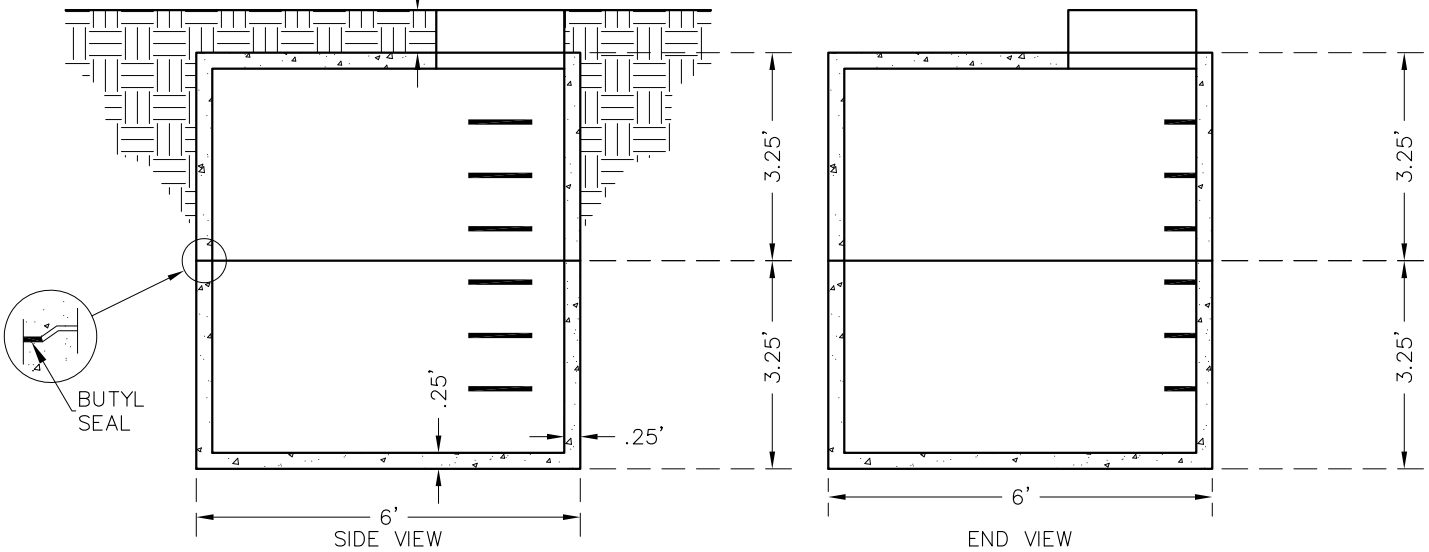

SIDE VIEW

END VIEW



CITY OF KALAMAZOO
Department Of Public Services

STANDARD METER PIT

RECOMMENDED BY _____

APPROVED BY _____

APPROVED BY _____

ACCEPTED BY _____

DATE

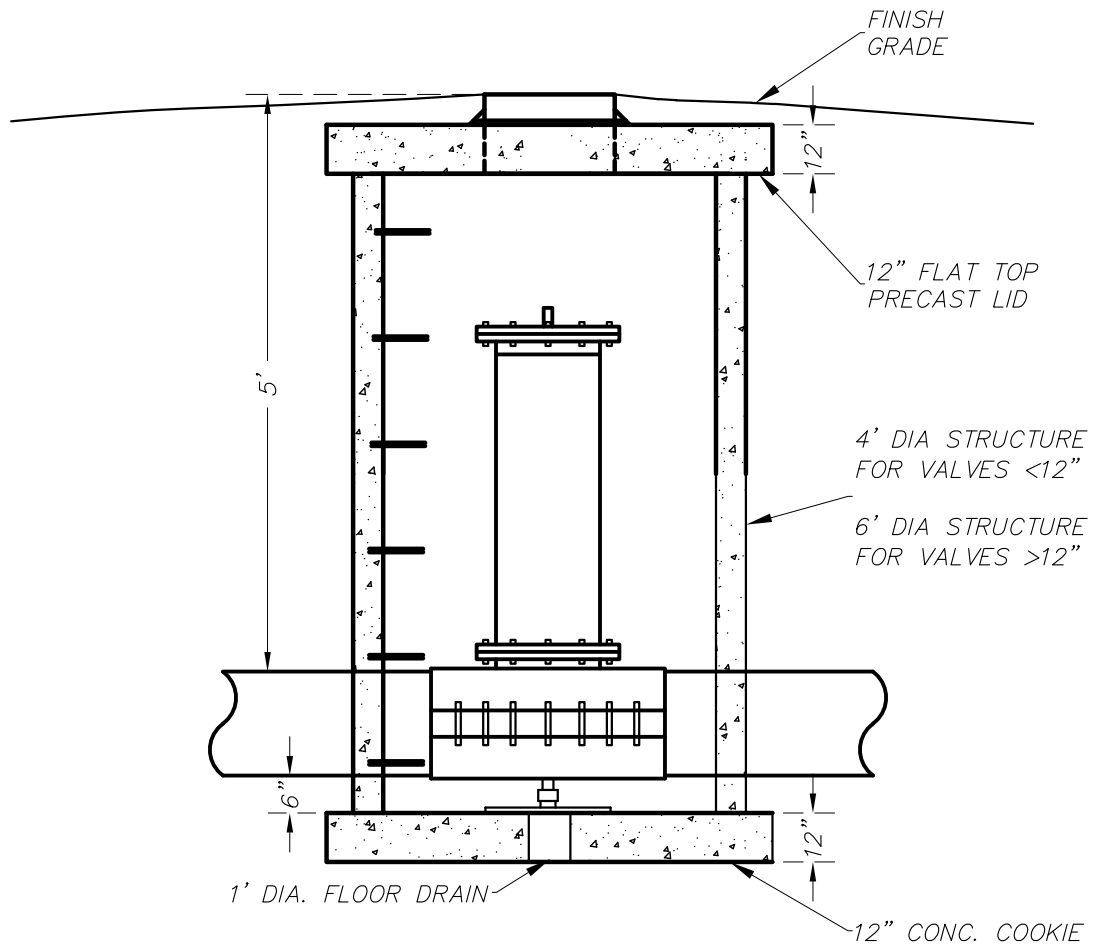
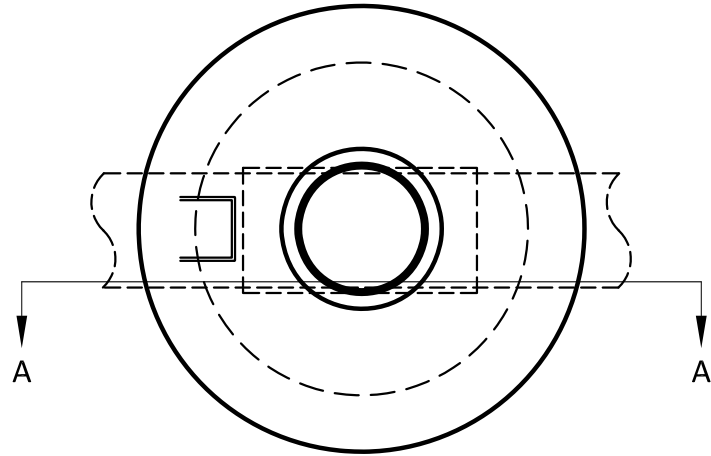

TYPICAL INSERTA – VALVE
PRECAST REINFORCED CONCRETE SHOWN

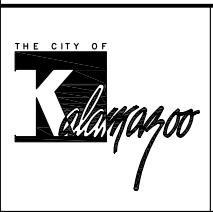

CITY OF KALAMAZOO
 Department Of Public Services

**INSERTA-VALVE
 STRUCTURE**

RECOMMENDED BY _____	DATE _____
APPROVED BY _____	
APPROVED BY _____	
ACCEPTED BY _____	

NOTES:

1. METER VAULT (PIT) DESIGN MUST BE SUBMITTED AND APPROVED FOR EACH INDIVIDUAL INSTALLATION. DESIGN SHALL CONFORM TO THE CITY OF KALAMAZOO STANDARD SPECIFICATIONS FOR WATER MAIN AND SERVICE INSTALLATION LATEST REVISION.
2. THE DISTANCE BETWEEN RUNGS, CLEATS & STEPS SHALL NOT EXCEED 12 INCHES AND SHALL BE UNIFORM THROUGHOUT THE LENGTH OF THE LADDER.
3. CURB BOX WILL BE INSTALLED AT THE WATER MAIN.
4. COVER FOR METER PIT & CURB BOX SHALL BE INSTALLED & MAINTAINED LEVEL WITH THE ADJACENT GROUND.

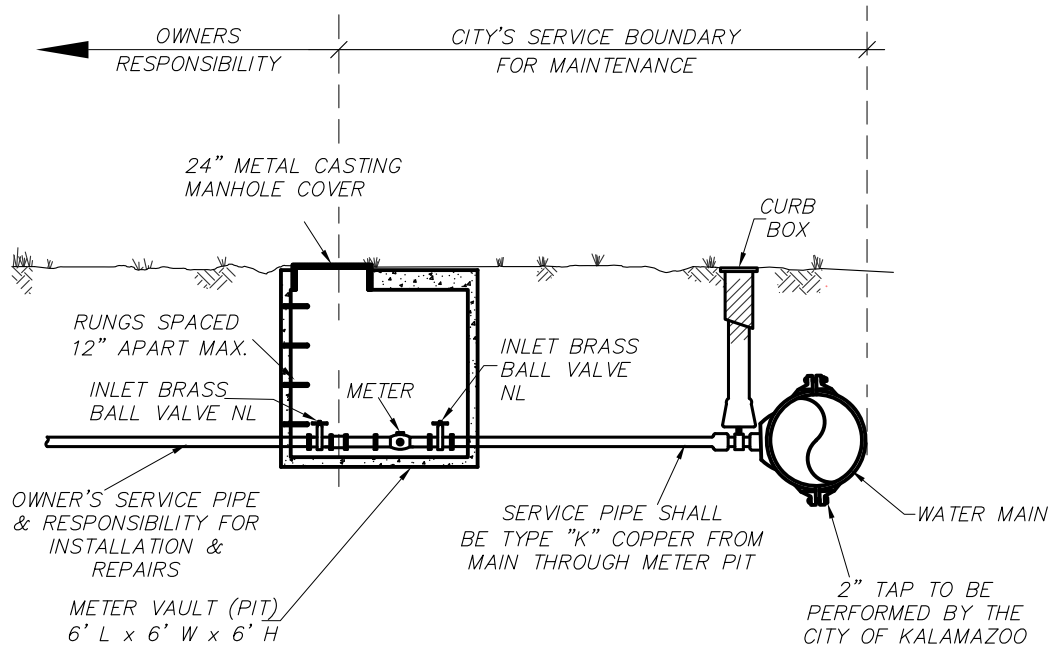

CITY OF KALAMAZOO
Department Of Public Services

**2" SERVICE LINE
METER VAULT**

RECOMMENDED BY _____

APPROVED BY _____

APPROVED BY _____

ACCEPTED BY _____

DATE

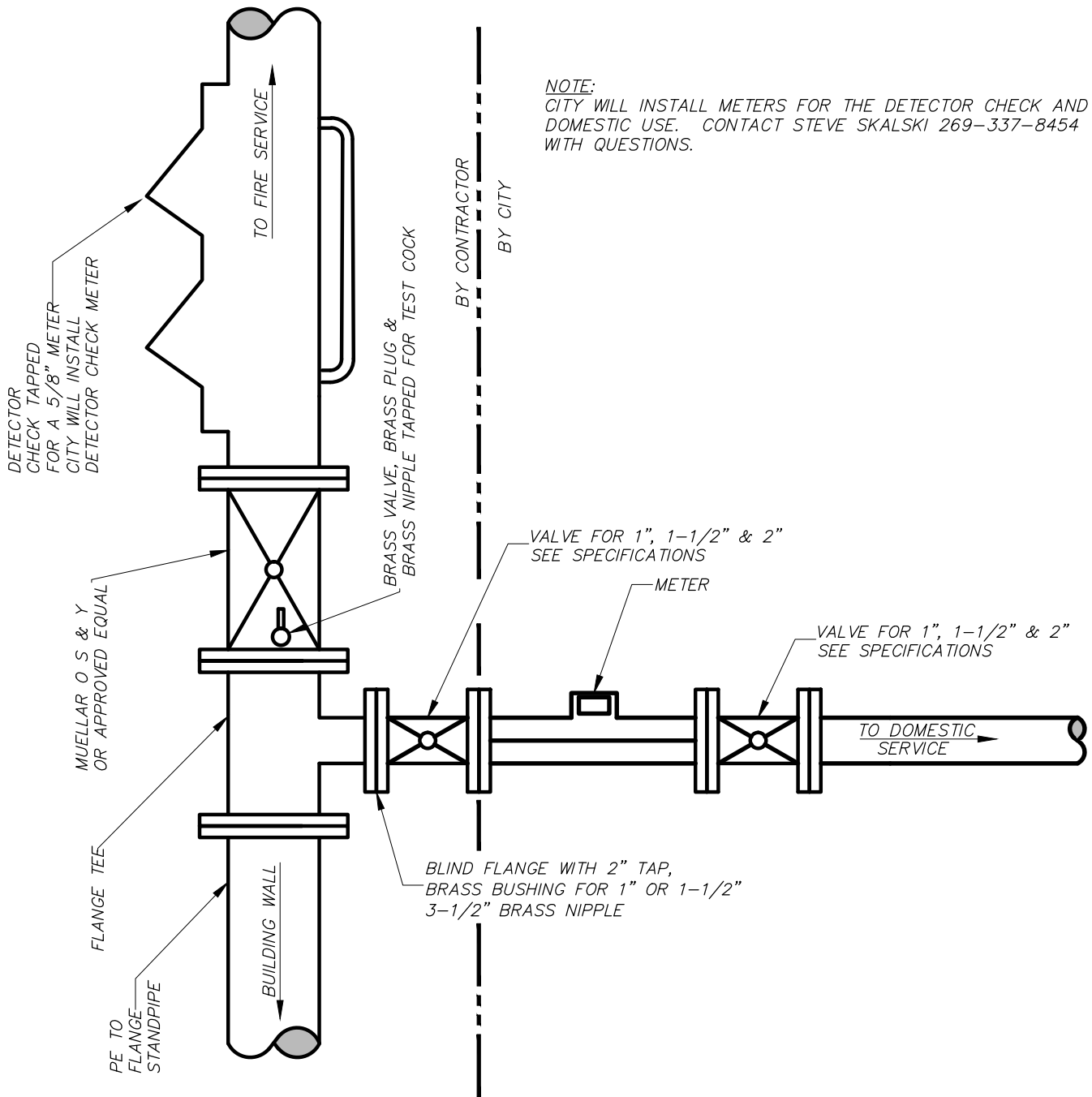

NOTE:
CITY WILL INSTALL METERS FOR THE DETECTOR CHECK AND DOMESTIC USE. CONTACT STEVE SKALSKI 269-337-8454 WITH QUESTIONS.



CITY OF KALAMAZOO
Department Of Public Services
TYPICAL FIRE SERVICE
DETAIL
1" 1-1/2" 2"

RECOMMENDED BY _____	DATE _____
APPROVED BY _____	
APPROVED BY _____	
ACCEPTED BY _____	

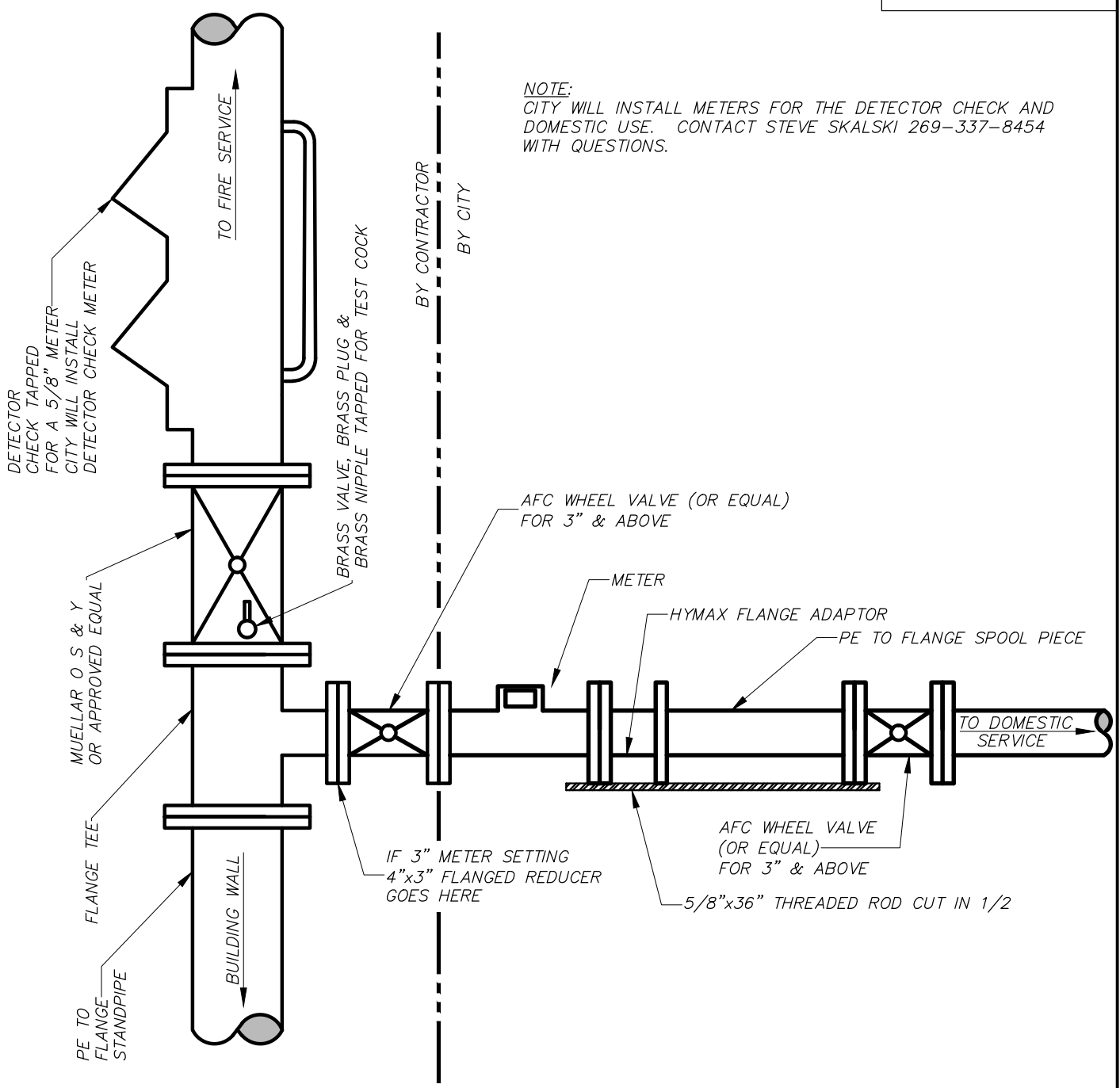

NOTE:
 CITY WILL INSTALL METERS FOR THE DETECTOR CHECK AND DOMESTIC USE. CONTACT STEVE SKALSKI 269-337-8454 WITH QUESTIONS.



CITY OF KALAMAZOO
 Department Of Public Services
**TYPICAL FIRE SERVICE
 DETAIL**
 3" 4" 6"

RECOMMENDED BY _____	DATE _____
APPROVED BY _____	
APPROVED BY _____	
ACCEPTED BY _____	

NOTES:

1. PLACEMENT OF STOP BOX CAN VARY FROM A MAXIMUM OF 5 FEET OUTSIDE THE PROPERTY LINE TO A MAXIMUM OF 5 FEET INSIDE THE PROPERTY LINE. PLACEMENT OF THE STOP BOX OUTSIDE THE PROPERTY LINE IS PREFERRED.

2. CITY WATER WILL REPAIR LEAKS ON SERVICE LINES WHEN NOTIFIED, FROM THE CORPORATION STOP TO METER.

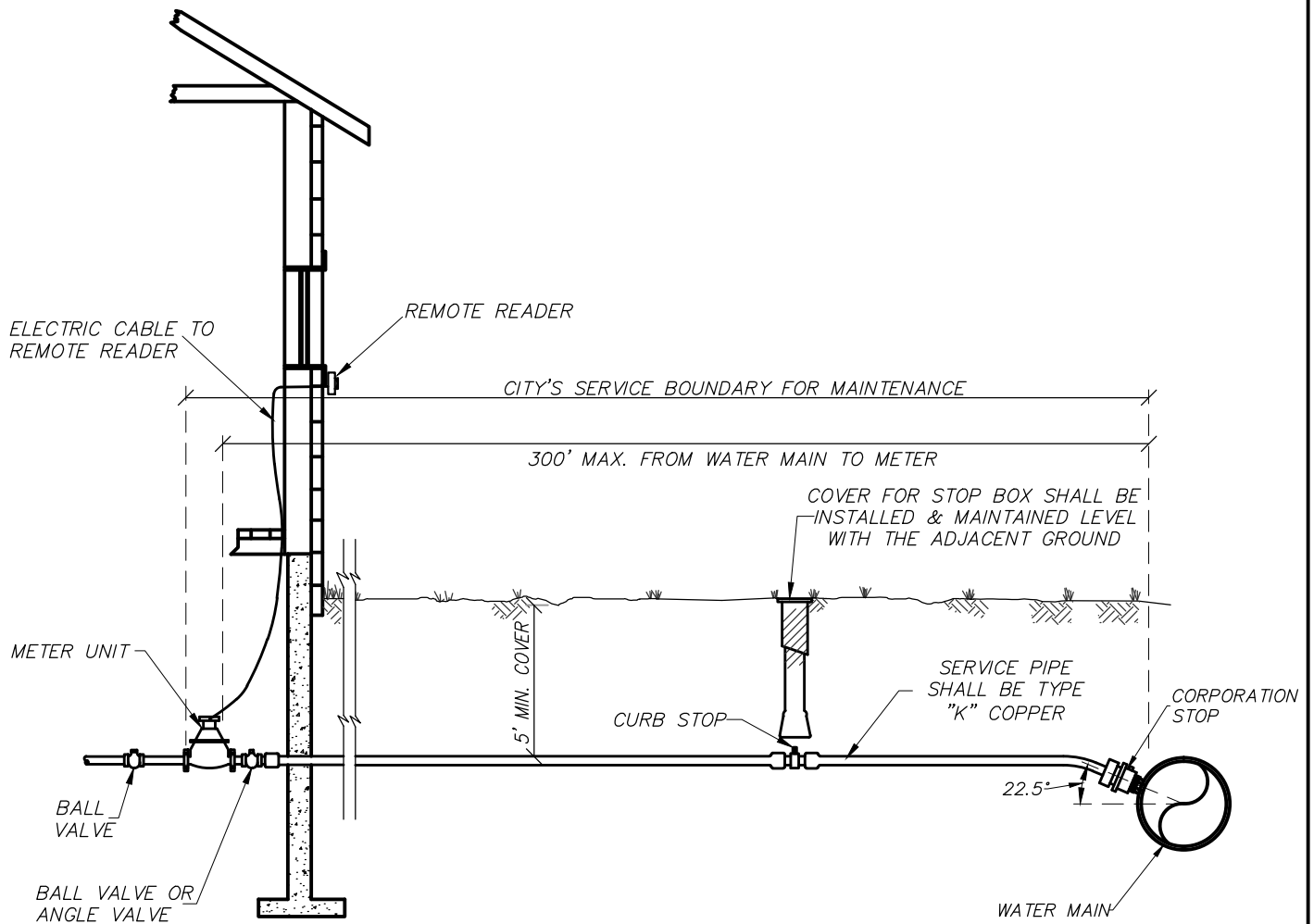

9/15/2015 1:27:03 PM



CITY OF KALAMAZOO
Department Of Public Services

**SERVICE LINE, STOP BOX AND
INSIDE METER INSTALLATION
1-1/4" SERVICE & 1" METER**

	DATE
RECOMMENDED BY _____	
APPROVED BY _____	
APPROVED BY _____	
ACCEPTED BY _____	

WS-7-A

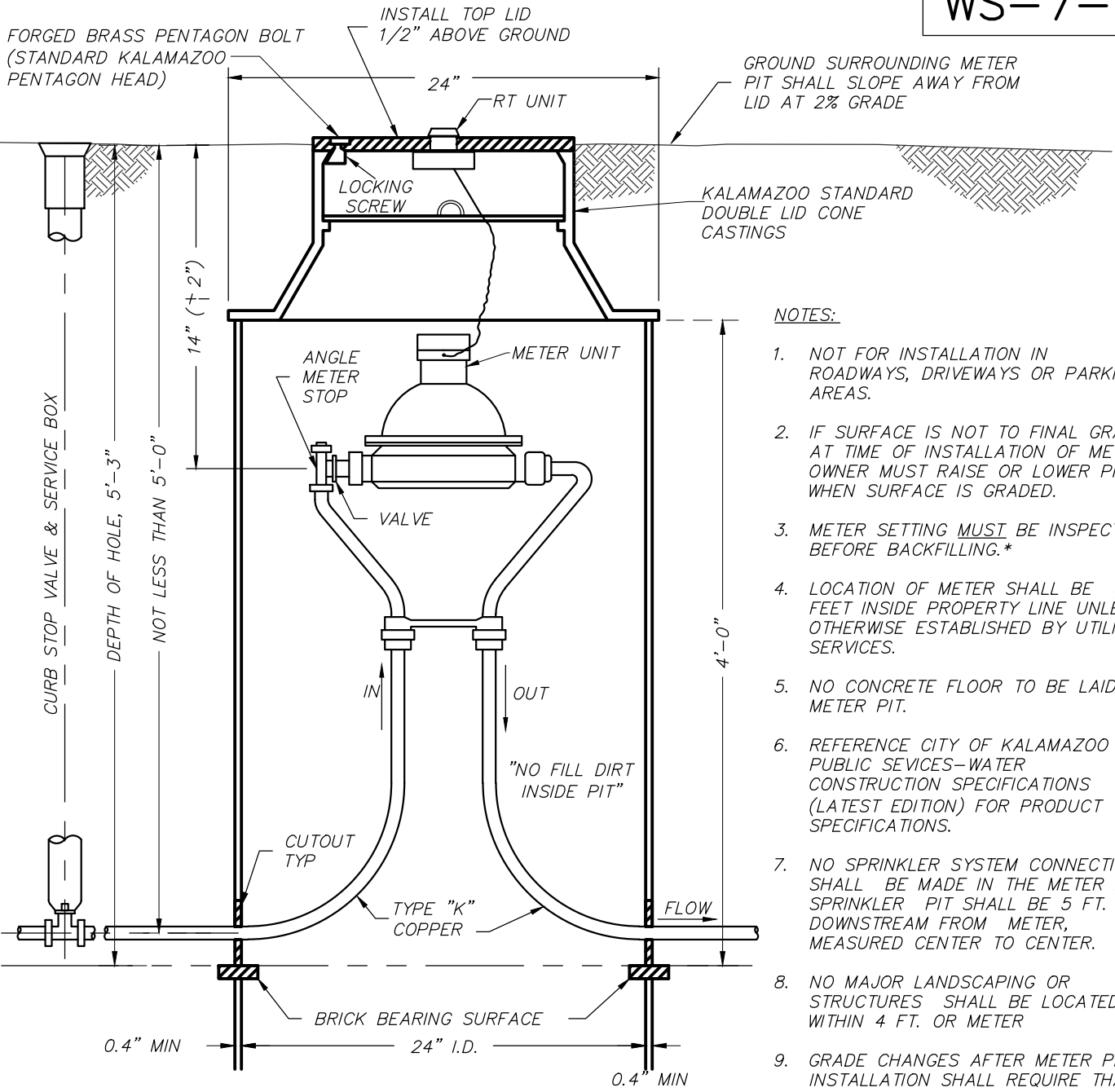

NOTES:

1. NOT FOR INSTALLATION IN ROADWAYS, DRIVEWAYS OR PARKING AREAS.
2. IF SURFACE IS NOT TO FINAL GRADE AT TIME OF INSTALLATION OF METER, OWNER MUST RAISE OR LOWER PIT WHEN SURFACE IS GRADED.
3. METER SETTING MUST BE INSPECTED BEFORE BACKFILLING.*
4. LOCATION OF METER SHALL BE 5 FEET INSIDE PROPERTY LINE UNLESS OTHERWISE ESTABLISHED BY UTILITY SERVICES.
5. NO CONCRETE FLOOR TO BE LAID IN METER PIT.
6. REFERENCE CITY OF KALAMAZOO PUBLIC SERVICES-WATER CONSTRUCTION SPECIFICATIONS (LATEST EDITION) FOR PRODUCT SPECIFICATIONS.
7. NO SPRINKLER SYSTEM CONNECTIONS SHALL BE MADE IN THE METER PIT. SPRINKLER PIT SHALL BE 5 FT. DOWNSTREAM FROM METER, MEASURED CENTER TO CENTER.
8. NO MAJOR LANDSCAPING OR STRUCTURES SHALL BE LOCATED WITHIN 4 FT. OF METER
9. GRADE CHANGES AFTER METER PIT INSTALLATION SHALL REQUIRE THAT THE OWNER ADJUST METER PIT COVER TO 1/2" ABOVE FINAL GRADE.
10. IF PRESSURE REDUCING VALVE IS REQUIRED BY PLUMBING CODE, IT SHALL BE INSTALLED INSIDE THE BUILDING, IMMEDIATELY FOLLOWING THE MAIN SHUT OFF VALVE.
11. COPPER PIPE SHALL SHOW NO VISIBLE CRIMPING.

* FOR INSPECTION CALL (269) 998-6433 INSPECTOR
 * FOR INSPECTION CALL (269) 337-8769 ENGINEER

J:\COK CAD STANDARDS\STANDARD DETAILS\WATER\UPDATED DRAWINGS\WS-7-A OUTSIDE METER 1 INCH.dwg, 4/1/2014 8:18:07 AM

	CITY OF KALAMAZOO Department Of Public Services	RECOMMENDED BY _____	DATE _____
	OUTSIDE SETTING FOR 1" METER	APPROVED BY _____	
		APPROVED BY _____	
		ACCEPTED BY _____	

NOTES:

PLACEMENT OF STOP BOX CAN VARY FROM A MAXIMUM OF 5 FOOT OUTSIDE THE PROPERTY LINE TO A MAXIMUM OF 5 FOOT INSIDE THE PROPERTY LINE TO AVOID SIDEWALK. PLACEMENT OF STOP BOX OUTSIDE THE PROPERTY LINE IS PREFERRED.

OWNER'S RESPONSIBILITY SHALL BE UP TO 5 FEET FROM THE METER PIT CUSTOMER SIDE.

WATER DEPARTMENT'S RESPONSIBILITY SHALL BE THE WATER MAIN, THE CORPORATION STOP AND SERVICE PIPING UP TO 5 FEET FROM THE METER

METER PIT AND COVER SHALL BE THE RESPONSIBILITY OF THE OWNER.

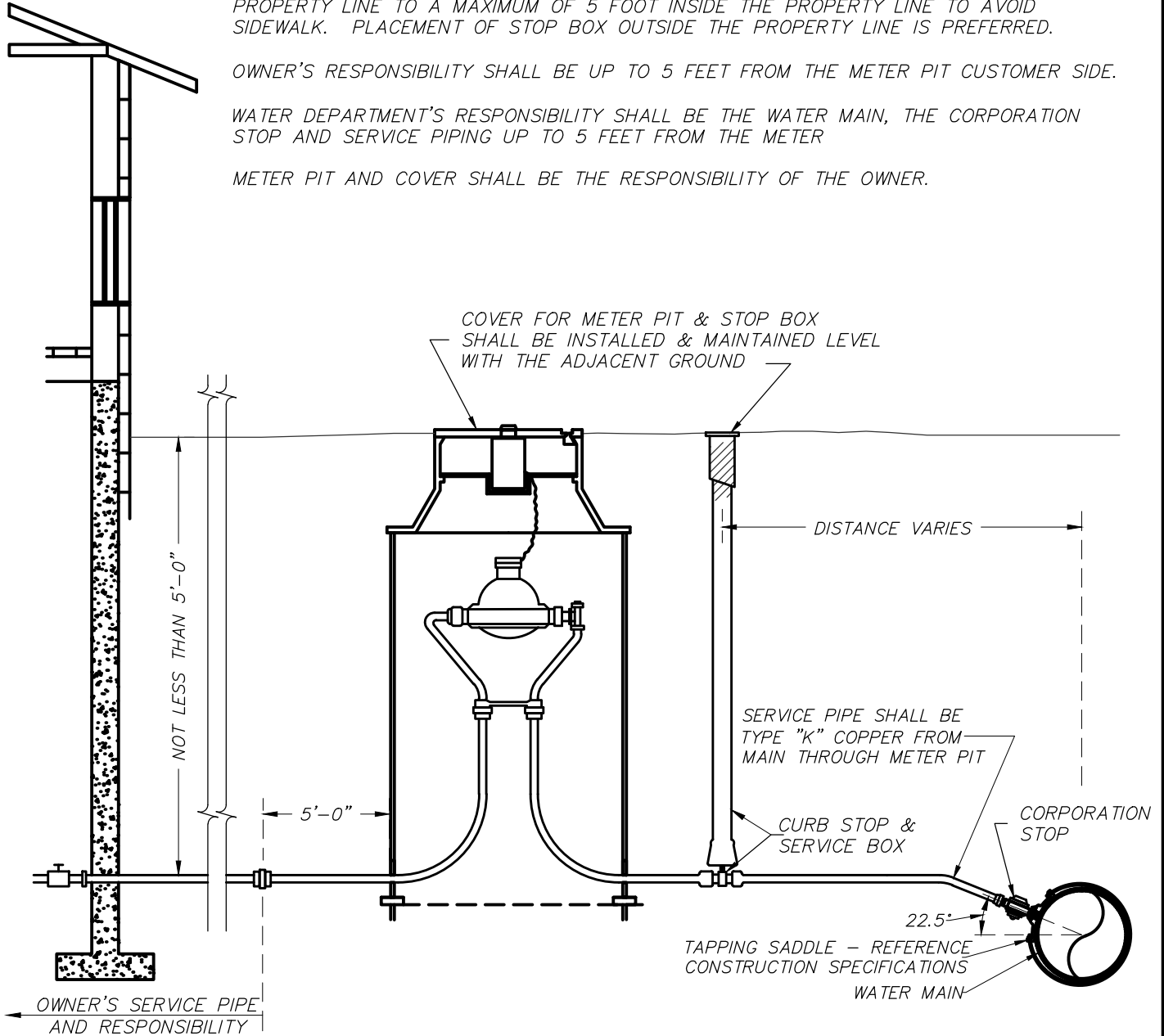

9/15/2015 12:06:36 PM



CITY OF KALAMAZOO
Department Of Public Services

**1-1/4" SERVICE LINE,
STOP BOX AND OUTSIDE
METER INSTALLATION**

RECOMMENDED BY _____	DATE _____
APPROVED BY _____	
APPROVED BY _____	
ACCEPTED BY _____	

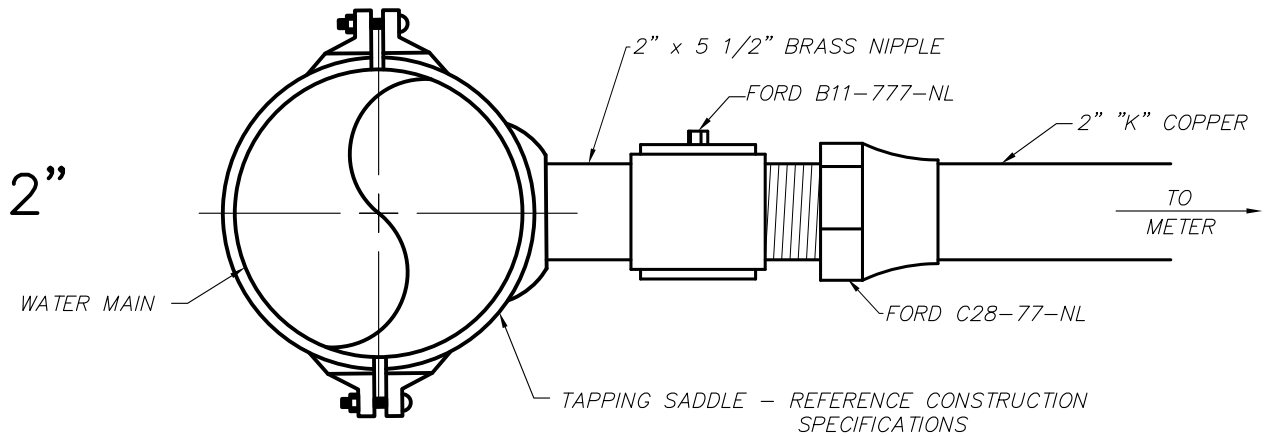
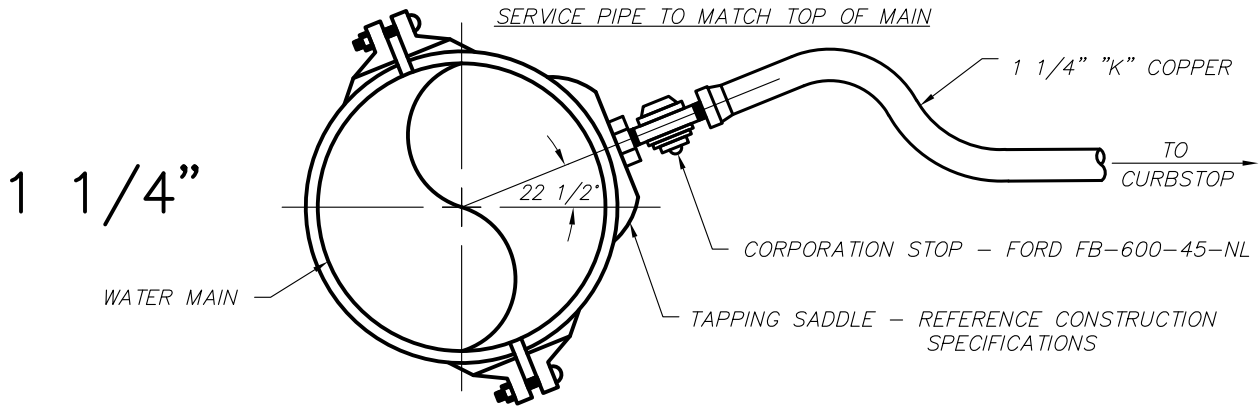

CITY OF KALAMAZOO
Department Of Public Services

**WATER SERVICE
TAPPING SLEEVE**

RECOMMENDED BY _____

APPROVED BY _____

APPROVED BY _____

ACCEPTED BY _____

DATE

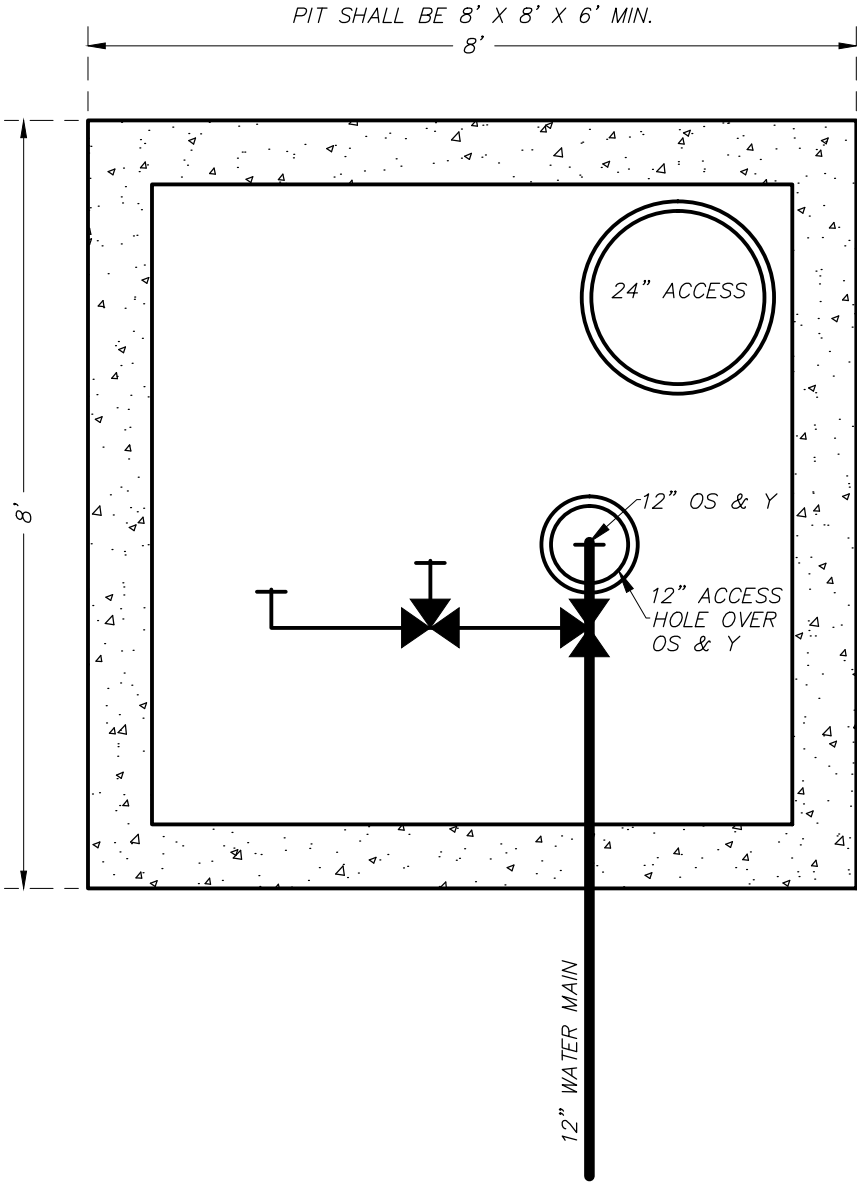

CITY OF KALAMAZOO
Department Of Public Services

12 INCH METER PIT

	DATE
RECOMMENDED BY _____	
APPROVED BY _____	
APPROVED BY _____	
ACCEPTED BY _____	

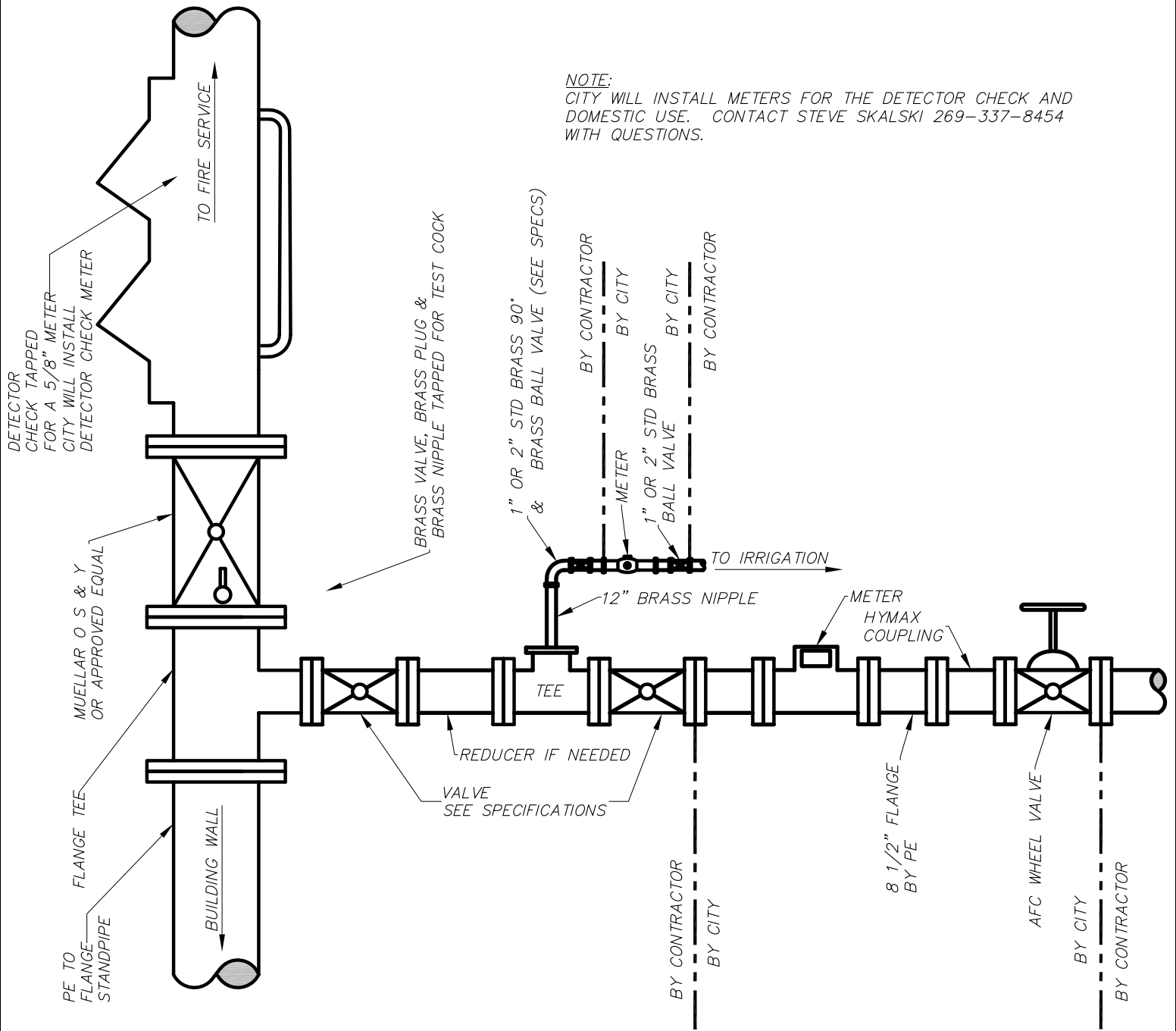

**TYPICAL FIRE SERVICE
DETAIL, DOMESTIC 3", 4",
& 6" & IRRIGATION 1" OR
2" VERTICAL SETTING**

RECOMMENDED BY _____

APPROVED BY _____

APPROVED BY _____

ACCEPTED BY _____

DATE

NOTE:
 CITY WILL INSTALL METERS FOR THE DETECTOR CHECK AND
 DOMESTIC USE. CONTACT STEVE SKALSKI 269-337-8454
 WITH QUESTIONS.

1" OR 2" STD. 90°
 W/1" OR 2" BRASS BALL VALVE
 OR FORD ANGLE VALVE
 (FV13-777W-NL) 2"
 (KV13-444W-NL) 1"

1" OR 2" X 12" BRASS NIPPLE

VALVE
 SEE SPECIFICATIONS

REDUCER
 (IF NEEDED)

TEE

TEE

PE TO
 FLANGE
 STANDPIPE

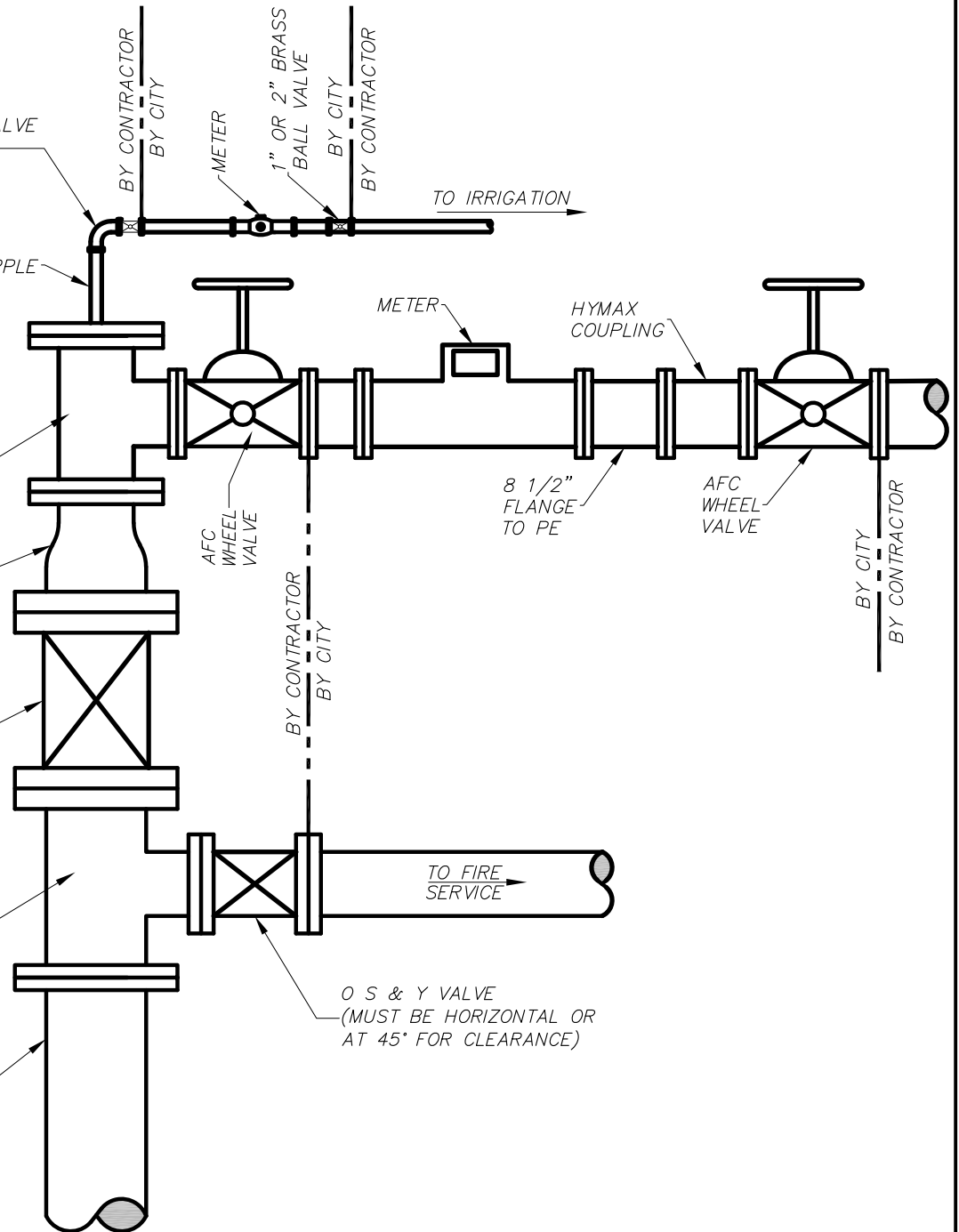

TO IRRIGATION

METER

HYMAX
 COUPLING

8 1/2"
 FLANGE
 TO PE

AFC
 WHEEL
 VALVE

AFC
 WHEEL
 VALVE

BY CONTRACTOR
 BY CITY

BY CITY
 BY CONTRACTOR

TO FIRE
 SERVICE

O S & Y VALVE
 (MUST BE HORIZONTAL OR
 AT 45° FOR CLEARANCE)



CITY OF KALAMAZOO
 Department Of Public Services
TYPICAL FIRE SERVICE DETAIL
HORIZONTAL SETTING
W/3", 4", OR 6" DOMESTIC
& 1" OR 2" IRRIGATION

RECOMMENDED BY _____	DATE _____
APPROVED BY _____	
APPROVED BY _____	
ACCEPTED BY _____	

NOTE:
 CITY WILL INSTALL METERS FOR THE DETECTOR CHECK AND
 DOMESTIC USE. CONTACT STEVE SKALSKI 269-337-8454
 WITH QUESTIONS.

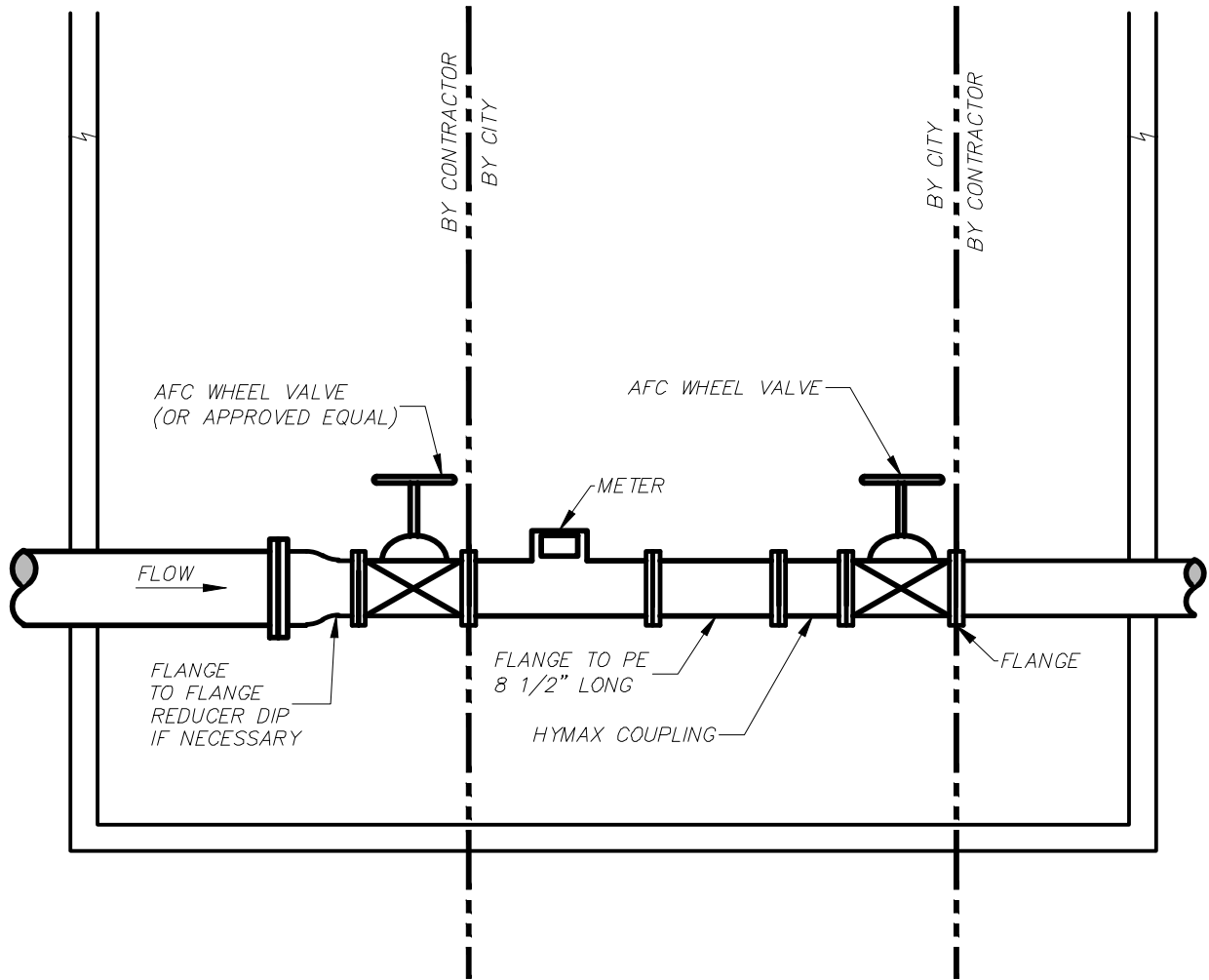

CITY OF KALAMAZOO
 Department Of Public Services
**PIT METER SETTING
 DETAIL FOR
 3", 4", 6" & 8"**

RECOMMENDED BY _____	DATE _____
APPROVED BY _____	
APPROVED BY _____	
ACCEPTED BY _____	

NOTE:
 CITY WILL INSTALL METERS FOR THE DETECTOR CHECK AND DOMESTIC USE. CONTACT STEVE SKALSKI 269-337-8454 WITH QUESTIONS.

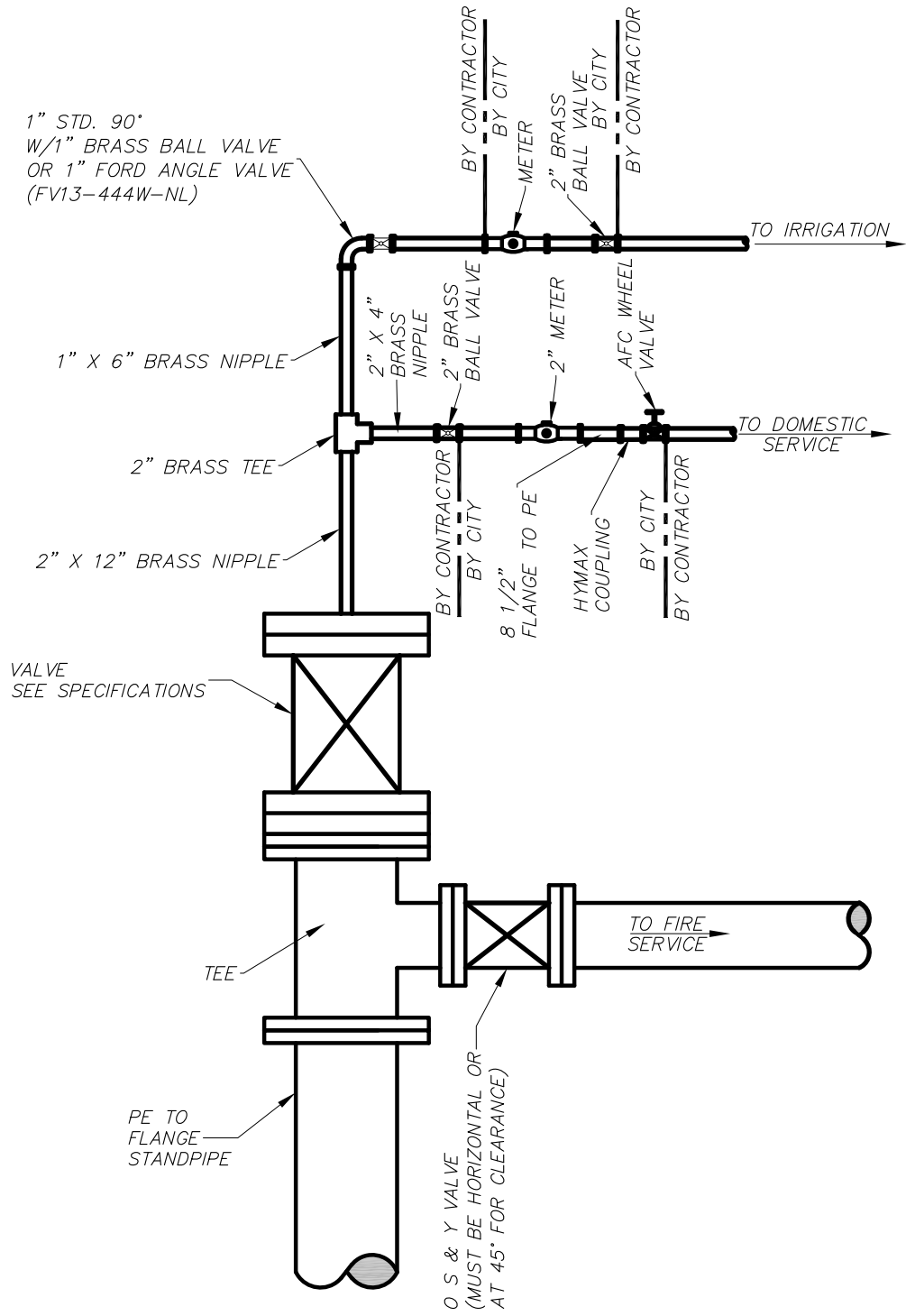

CITY OF KALAMAZOO
 Department Of Public Services
**TYPICAL FIRE SERVICE DETAIL
 HORIZONTAL SETTING
 2" DOMESTIC
 1" IRRIGATION**

RECOMMENDED BY _____	DATE _____
APPROVED BY _____	
APPROVED BY _____	
ACCEPTED BY _____	

NOTE:
 CITY WILL INSTALL METERS FOR THE DETECTOR CHECK AND
 DOMESTIC USE. CONTACT STEVE SKALSKI 269-337-8454
 WITH QUESTIONS.

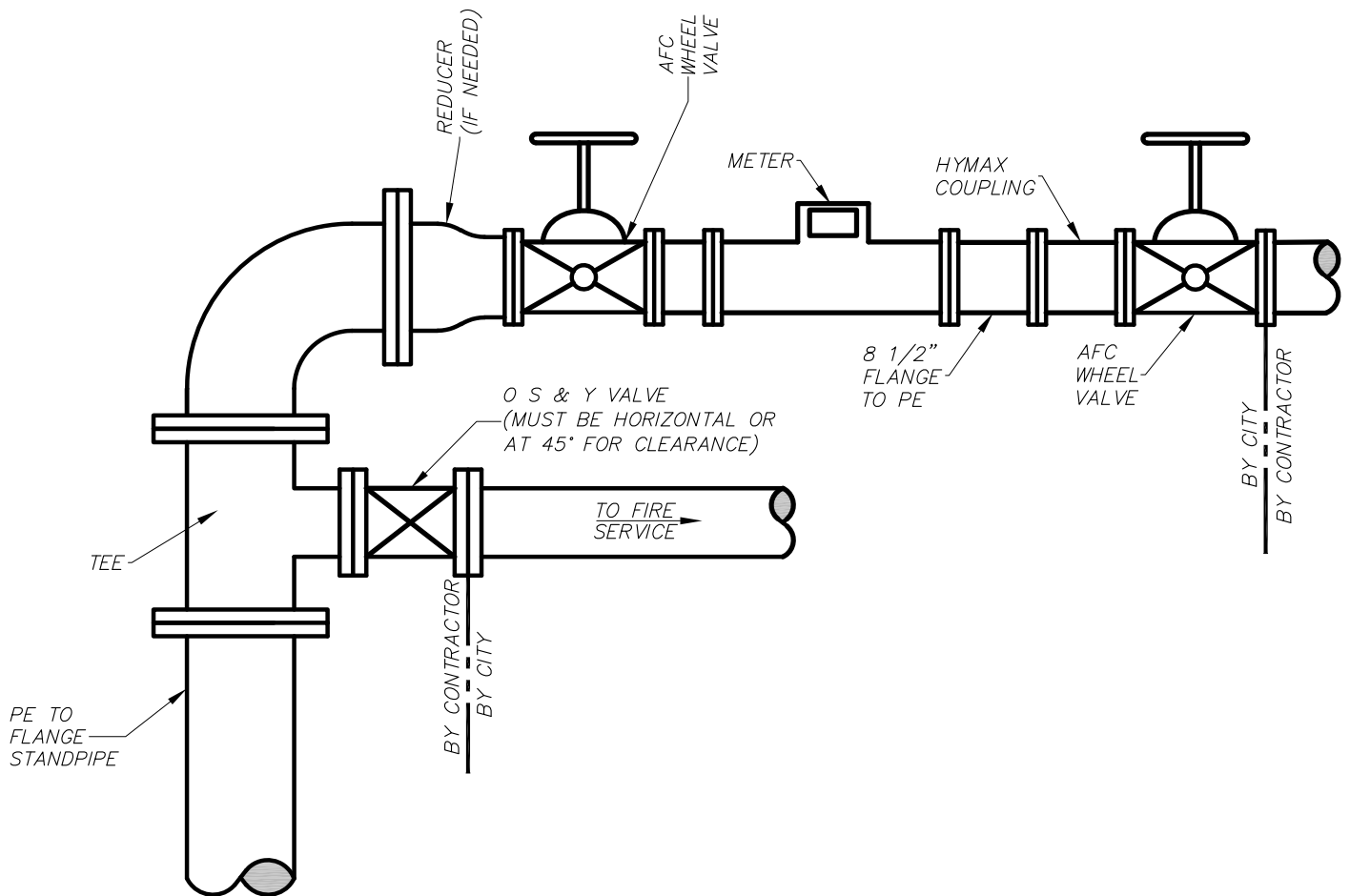

CITY OF KALAMAZOO
 Department Of Public Services

**TYPICAL FIRE SERVICE DETAIL
 HORIZONTAL SETTING
 W/3", 4", OR 6" DOMESTIC**

RECOMMENDED BY _____

APPROVED BY _____

APPROVED BY _____

ACCEPTED BY _____

DATE

WS-16-A

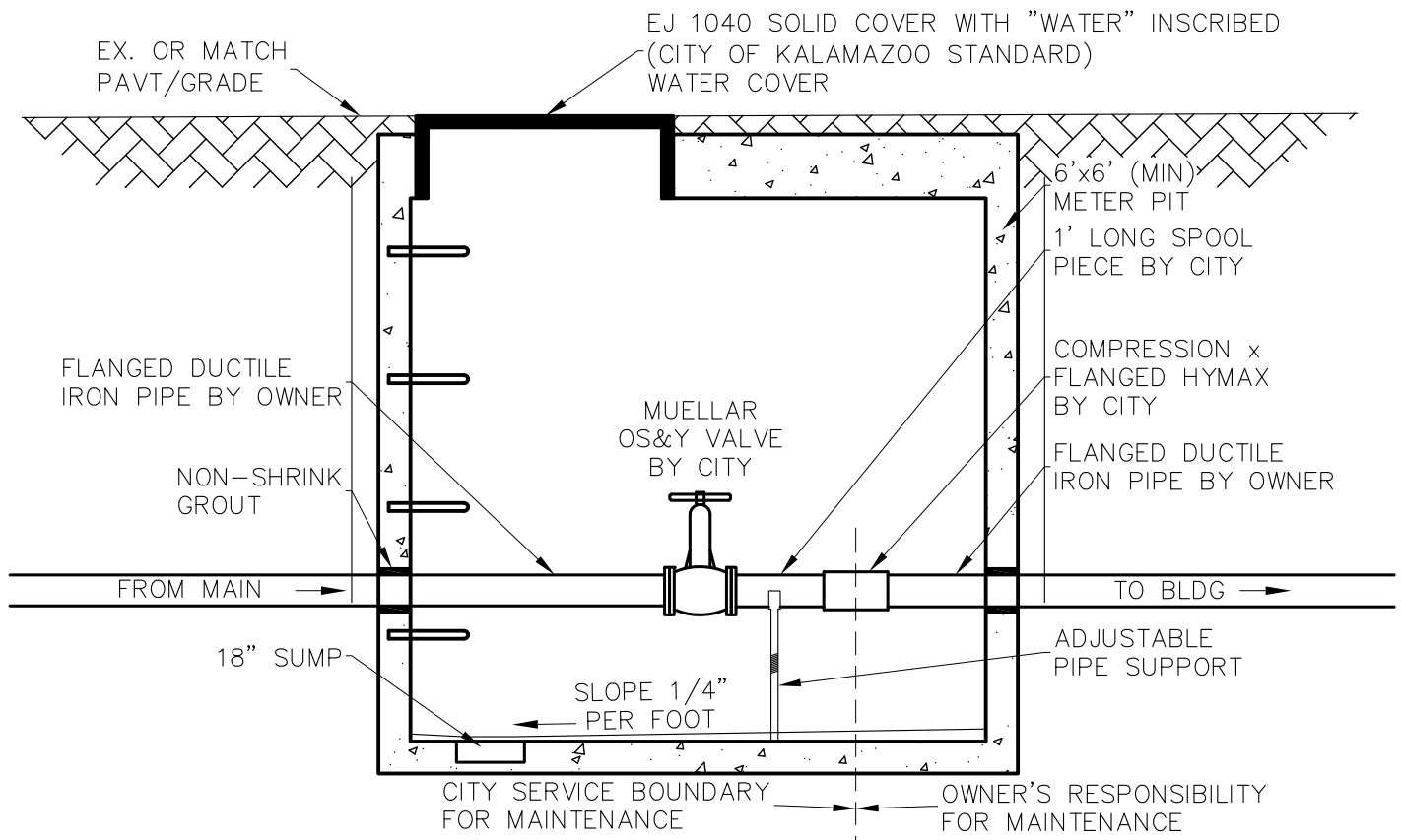
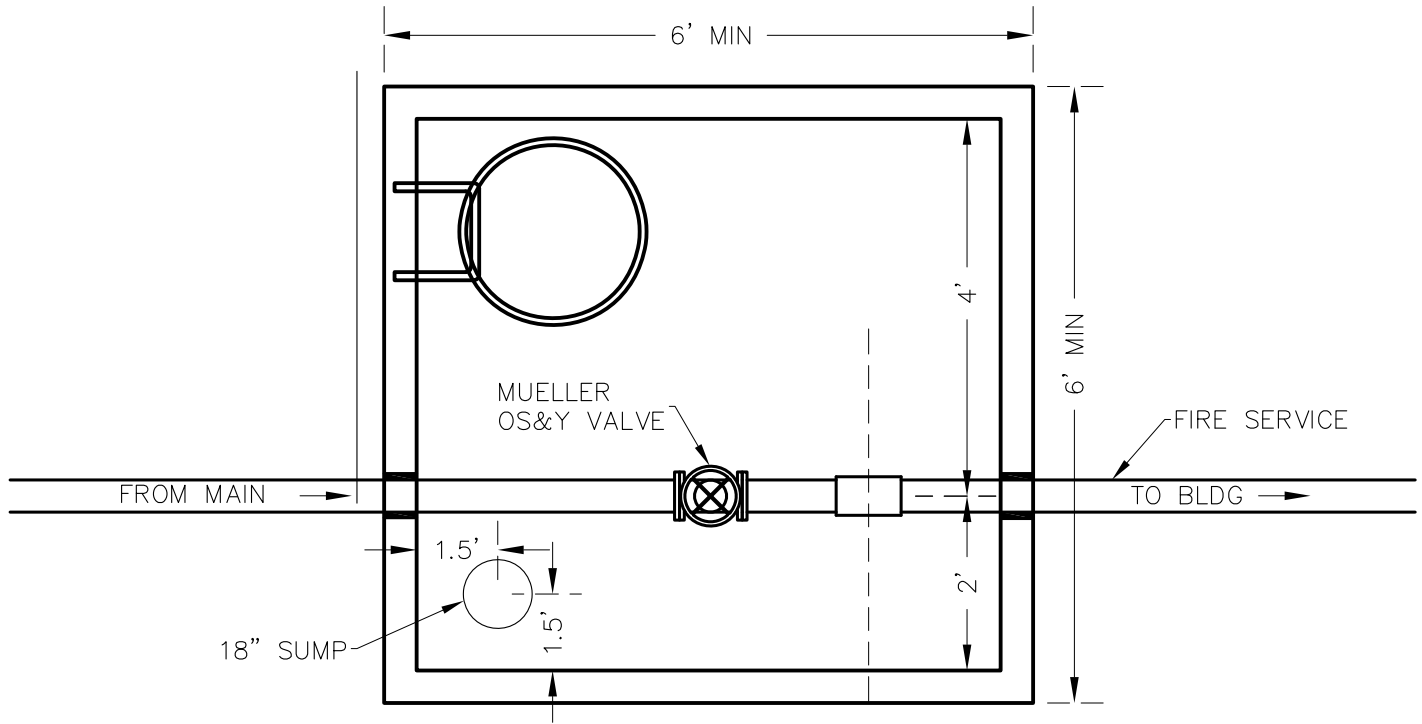

CITY OF KALAMAZOO
Department Of Public Services

**FIRE SERVICE
IN PIT DETAIL**

RECOMMENDED BY _____

APPROVED BY _____

APPROVED BY _____

ACCEPTED BY _____

DATE